



Controlled Start for Drill Motors on Roof Bolting Machines

Objective

To provide a practical method to reduce hand and arm injuries during roof bolting operations.

Background

Operators of roof bolting machines have one of the most dangerous jobs in underground mining (figure 1). The main hazards include unsupported roof and movement of equipment and machine appendages in confined surroundings. Many bolter operators have been injured because their hands or gloves have been caught by rotating drill steels or bolt wrenches. A bolter operator must manually place the drill steel and wrench into the drill chuck and then hold onto it as the drill is guided to the hole placement or the wrench is raised to the bolt head. During these actions, the inadvertent actuation of the drill's rotational control can catch the operator's hand or glove, which can cause serious injury.

Approach

The National Institute for Occupational Safety and Health (NIOSH), Pittsburgh Research Laboratory, has developed a mechanical/hydraulic method to reduce this type of injury. Although an experienced bolter operator can sometimes "feather" the hydraulic controls on modern bolting machines to achieve a relatively slow rotational speed, the control designs are not normally optimized for this. Inadvertent control actuation invariably results in full-on operation. The main reason for these types of incidents is that the sudden full-speed rotation of the drill catches the operator by surprise. The technique that we developed intentionally limits the rotational speed and torque of the hydraulic drill motor(s) for several seconds during startup. During this time,

the operator has the chance to see that drill rotation has started and can stop the rotation or release his/her hand before injury occurs. The technology is suited for incorporation into new machine designs by the manufacturer or implementation by mines or rebuild shops on a retrofit basis.

How It Works

A controlled start of the drill motor can be achieved in many ways. This *Technology News* describes three designs and their respective advantages and disadvantages. A feature common to all of the designs is that they use a rising pressure in an accumulator to control the starting characteristics of the drill motor. All of the designs use the bolting machine's existing hydraulic pumps and drill motors.

The first design is shown in figure 2. As pressure in the accumulator rises, the circuit provides the drill motor a reduced flow through the flow control and limited pressure through the pressure-reducing valve. The reduced pressure limits motor torque, and the reduced flow causes lowered motor rpm. As the accumulator fills, pressure builds behind the counterbalance valve. When sufficient pressure is built up, the counterbalance valve opens, allowing almost full flow and pressure to the hydraulic motor. A small restriction ahead of the counterbalance valve is needed to keep the accumulator charged, providing pressure to keep the counterbalance valve open. The check valve in the counterbalance valve provides for reverse motor rotation. The accumulator is drained when the operator releases the control lever to its center position, ensuring a controlled start each time. The action of this controlled start is like a shift in an automatic transmission. First there is low torque and rpm at the drill motor, which shifts to high rpm and torque when the counterbalance valve opens. This design is fairly simple, but not ideal because additional oil heating occurs. If this circuit were to be implemented, one needs to carefully consider the ability of the oil cooler on the



equipment to remove the added heat. This design also precludes the controlled start feature in the reverse rotation direction, and maximum drill speed is slightly reduced.

Figure 3 shows another design. In this circuit, the drill motor's initial rotational speed is very slow, then ramps up to its maximum rpm. The size of the accumulator and the setting of the flow control valve controls the slope of the ramp. A pilot signal is delivered to the pilot-operated flow control from the rising pressure in the accumulator. This causes flow to the motor to slowly increase. Depending on the exact design requirements of flow and pressure, the pilot-operated flow control may be difficult to procure, as these are normally available in limited sizes. It would be possible to substitute a pilot-operated poppet valve with a custom-machined internal spool. A poppet valve is normally designed as an on/off device, and its internal spool has sharp edges on its lands to perform this function. Since flow control is desired, it would be necessary to have the internal spool designed and machined with tapers instead of sharp edges. This would provide the desired flow control action and should be available for a modest cost. In this design, as in the first, there is no provision for a controlled start during reverse rotation. Also, the drill torque is not as closely controlled as in the first design.

The final design, shown in figure 4, is slightly more complex, but offers more efficiency and control. This design requires a separate charging or pilot circuit for operation. This should not be a problem, because most roof bolting machines have many hydraulic circuits available. In this design, the operator controls a small flow through a manual valve into an accumulator. Figure 4 shows an open-center spool on the manual valve. Depending on the application, this may need to be changed to a motor-style spool. The pressure signal from the accumulator is connected to a pilot-operated proportional four-way valve that controls the drill motor. This type of valve delivers and regulates flow in proportion to the pressure on its pilot ports. The operator would have little or no control over the starting characteristics of the drill. This would be entirely controlled by the size of the accumulator and the setting of the flow controls. As in the second design, the motor start is a

controlled ramp from zero to maximum rpm. An advantage of this design is that the volume of the accumulators is much smaller than that required by the other designs. This design provides for a reverse controlled start with an independently controlled ramp speed.

Patent Status

The controlled start hydraulic systems have been assembled and tested in the laboratory to ensure that they function as designed. Also, we have presented the concept and designs to a major roof bolter manufacturer, who has agreed on their principle of operation, practicality, and usefulness. This manufacturer is in the process of implementing an electronic version of a controlled start method, as this fits well their new electronic control system. The mechanical/hydraulic methods described should be applicable to traditional, hydraulically controlled bolting machines.

For More Information

For more information, contact Joseph P. DuCarme, NIOSH Pittsburgh Research Laboratory, Cochran's Mill Rd., P.O. Box 18070, Pittsburgh, PA 15236-0070, phone: (412) 386-6728, fax: (412) 386-5108, e-mail: jld6@cdc.gov

To receive additional information about occupational safety and health problems, call 1-800-35-NIOSH (1-800-356-4674), or visit the NIOSH Web site at www.cdc.gov/niosh

Mention of any company name or product does not constitute endorsement by the National Institute for Occupational Safety and Health.



Figure 1.—Bolter operator beginning drilling procedure.

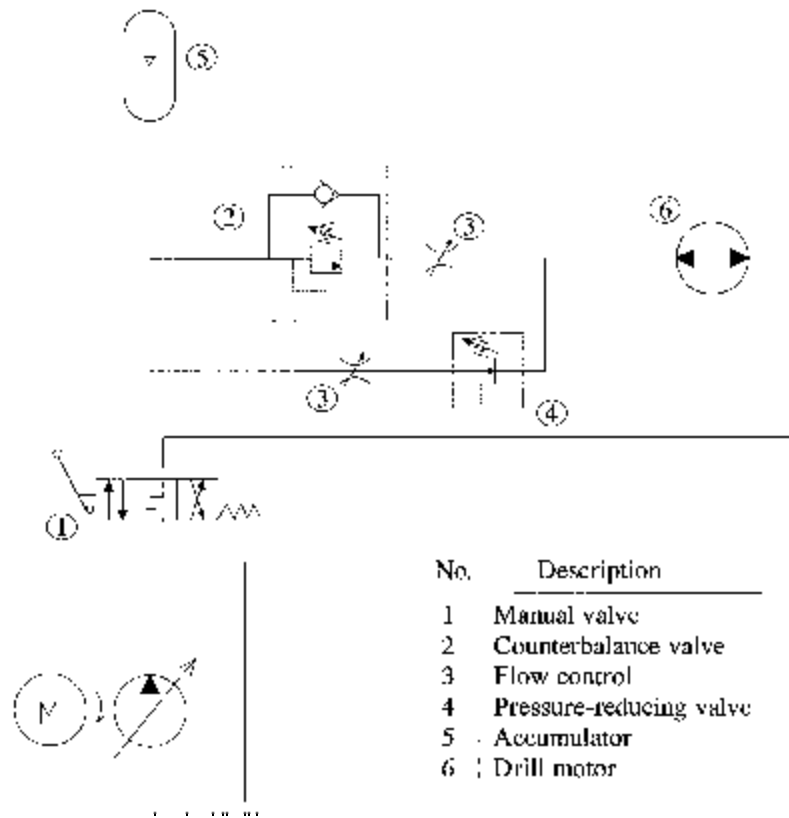

Figure 2.—Controlled start design using counterbalance valve.

