

ENGINEERING REPORT

MAGNETIC FIELD STRENGTH MAPPING OF
THE HELVETIA COAL CO. LUCERNE #8
MINE AT MEDIUM FREQUENCY

-Contour maps of magnetic field strength
along North and South Main haulageways
are presented at frequencies of 71,225,
910, and 2890 KHz-

PREPARED FOR:

U.S. Bureau of Mines
PMSRC
Cochran Mill Road
Bruceston, Pennsylvania

Under: U.S. Bureau of Mines P0372716

PREPARED BY:

Terry S. Cory, P.E.
2315 Linden Dr. S.E.
Cedar Rapids, Iowa 52403

- September 1977 -

ENGINEERING REPORT

MAGNETIC FIELD STRENGTH MAPPING OF
THE HELVETIA COAL CO. LUCERNE #8
MINE AT MEDIUM FREQUENCY

-Contour maps of magnetic field strength
along North and South Main haulageways
are presented at frequencies of 71,225,
910, and 2890 KHz-

PREPARED FOR:

U.S. Bureau of Mines
PMSRC
Cochran Mill Road
Bruceton, Pennsylvania

Under: U.S. Bureau of Mines P0372716

PREPARED BY:

Terry S. Cory, P.E.
2315 Linden Dr. S.E.
Cedar Rapids, Iowa 52403

- September 1977 -

TABLE OF CONTENTS

	PAGE
1.0 Introduction	1-1
1.1 General Background	1-1
1.2 Description of the Test Environment	1-2
2.0 Summary of Results	2-1
3.0 Experimental Approach	3-1
4.0 Data Reduction Techniques	4-1
APPENDIX - Raw and Reduced Data from the Lucerne #8 Mine Testing	A-1

TABLE OF ILLUSTRATIONS

FIGURE		PAGE
1-1	Map of Lucerne #8 Mine Showing Transmitter Location and Field Strength Test Locations In North and South Mains	1-3
3-1	Main Haulage Entry Crosssections Geometry for Measurements	3-2
3-2	Transmitter Equipment Used for 71 KHz	3-5
3-3	Transmitter Equipment Used for 225,910, and 2890 KHz	3-6
3-4	Magnetic Field Strength Coverage Map of Lucerne #8 Mine With the Transmitter Placed Adjacent to the Power Cable at the Junction of the North & South Mains Belt Entries - 71 KHz	3-7
3-5	Magnetic Field Strength Coverage Map of Lucerne #8 Mine With the Transmitter Placed Adjacent to the Power Cable at the junction of the North & South Mains Belt Entries - 225 KHz	3-8
3-6	Magnetic Field Strength Coverage Map of Lucerne #8 Mine With the Transmitter Placed Adjacent to the Power Cable at the Junction of the North & South Mains Belt Entries - 910 KHz	3-9
3-7	Magnetic Field Strength Coverage Map of Lucerne #8 Mine With the Transmitter Placed Adjacent to the Power Cable at the junction of the North & South Mains Belt Entries - 2890 KHz	3-10

1.0 INTRODUCTION

1.1 GENERAL BACKGROUND

This report describes magnetic field measurements in the Helvetia Coal Co. Lucene #8 Mine for purposes of deriving a mapping of the magnetic field strength covering the major haulageways which contain conductors.

The measurements were performed by Terry S. Cory, P.E. under U.S. Bureau of Mines purchase order P0372716. Assisting in performance of the measurements were personnel from the Bureau of Mines, PMSRC, and Helvetia Coal Co.

Acknowledgement is given to Engineer Tom Strong of Helvetia Coal Co. who accompanied the measurement team and who lended support in performing the measurements and in supplying valuable engineering information for use in evaluation of the results.

The results of the testing at medium frequency show that coverage of the entire mine area containing conductors can be achieved employing wireless radio techniques whereby radio signals are coupled into and are carried by these conductors. These results confirm earlier qualitative testing of the Collins Mine Wireless Radios in this mine. These results, performed over the frequency range 71-2890 KHz, illustrate the effect of frequency on the radio propagation with the conclusion that the best overall coverage is obtained at frequencies approximating 1000 KHz.

This report presents all the raw data and the reduced data in the form of magnetic field strength contour maps. Sufficient information is provided to enable independent reduction of the data. A summary of observations which can be made directly from the contour maps is given.

1.2 DESCRIPTION OF THE TEST ENVIRONMENT

The Lucerne #8 Mine is in low coal in the upper Freeport (E) seam in Indiana County, Pennsylvania. Haulage entries in this nominally 42-inch seam have been trenched out to a height of about 6 feet, thus accomodating vehicles designed for high coal. This newly developing mine is currently less than a mile square. The mine is AC only, employing belt haulage and battery operated tracked service vehicles.

The measurements were performed over the existing extent of the North and South Main haulageways with supplementary data gathered in the adjacent entries and in butt sections off the North Mains. The measurements were performed by two teams working away from a single transmitter and employed specific measurement locations as shown on the mine map of Figure 1-1. Details of the haulageway entry crosssectional geometries are given in Section 3 to follow. These entries contained the belt, 7200 VAC power cable, phone line, and track at a minimum. The Mains consist of a 7 or 8 entry pattern with pillars on 60-70 foot centers. The 3 or 4 central entries are fresh air and the two outside entries on each side of the pattern are return air.

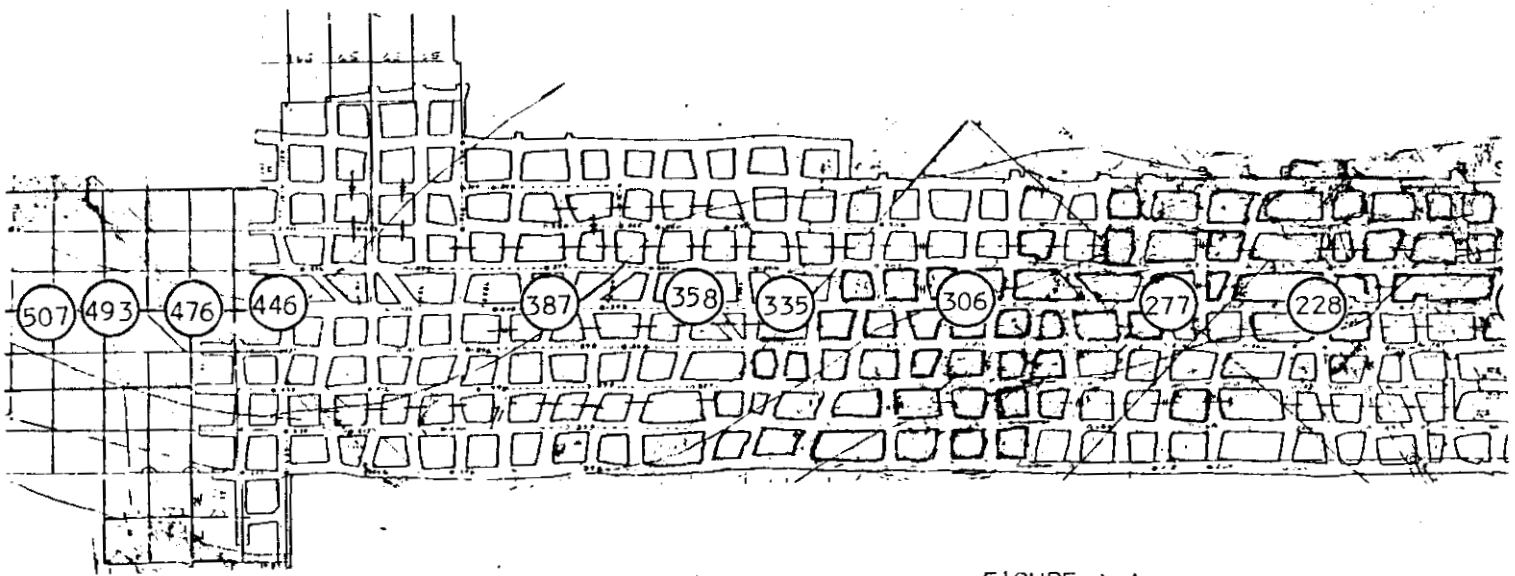
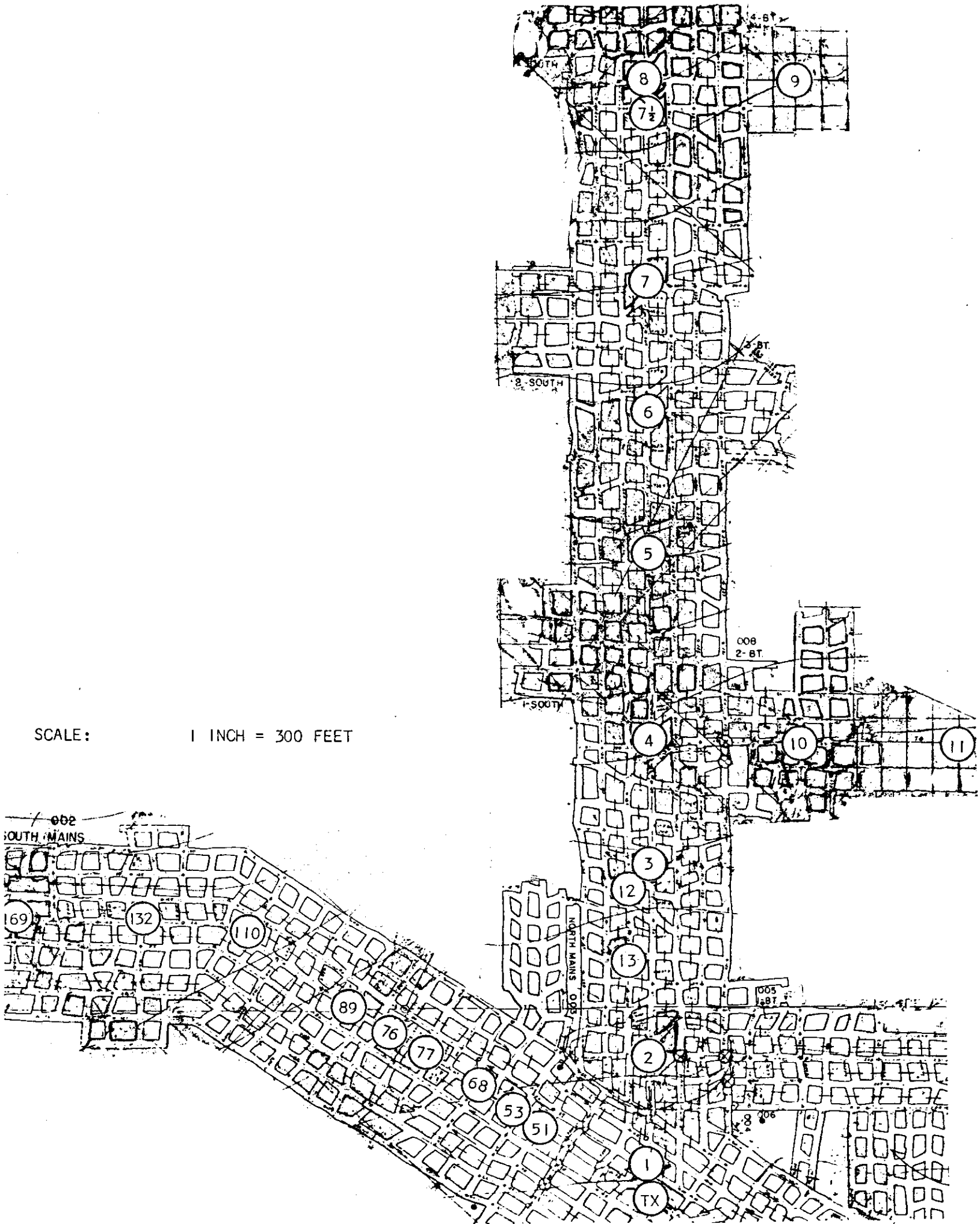

FIGURE 1-1

MAP OF LUCERNE #8 MINE SHOWING TRANSMITTER LOCATION
AND FIELD STRENGTH TEST LOCATIONS IN NORTH & SOUTH MAINS

SCALE: 1 INCH = 300 FEET



2.0 SUMMARY OF RESULTS

Generally, the results of the field strength mapping at 71, 225, 910, and 2890 KHz show that field strength levels in entries containing conductors are high enough to support "wireless" communications throughout the existing mine. This is a qualitative judgement based on the fact that it was possible to measure signal levels using the field strength meters in all except a few of the measurement locations at 71 KHz. As expected, the field strength levels increased with increase in frequency due to the improved coupling into the mine wiring. This does not mean that the ultimate maximum communication range for transmitters and receivers both closely coupled to the conductors increases in a similar manner as the attenuation, once coupling into a conductor has been achieved, is quite low at low frequencies (barring variation in field strength levels due to standing waves along conductors).

Estimates of the field strength in the supposedly conductor-free "angular sector" region between the North and South Mains show increasing coverage with increase in frequency over the test frequencies used. These estimates were provided by the contours drawn joining areas in the respective North and South Mains. Correspondingly, the fields were clearly closely bound to the conductors at 71 KHz.

From the junction point where the transmitter was located, the North and South Mains were rather symmetrically excited at the lower frequencies. At the higher frequencies, the South Main conductors were excited more strongly by a factor of from 10 to 20 dB.

At higher frequencies, the fields coupled parasitically to conductors in adjacent entries. This was clearly demonstrated in the South Main in the region of Tag Location 335 where coupling at 71 KHz to conductors in the adjacent right-hand entry was barely noticeable , but coupling at 910 KHz was such that near-equal field strengths were produced by the excited and parasitic conductors.

The effect of standing waves along conductors was much more apparent at the higher frequencies than at the lower frequencies. Max-to-min field strength readings between high and low signal standing wave points were typically 20-25 dB. The resolution of the measurement point locations was not sufficient to positively identify the maximum and minimum standing wave points although the reduced field strength contour maps provide the best estimates of these points which can be obtained from the test data.

Except for a few points at 71 KHz, the measured field strength was greatest near the AC power cable and decreased monotonically across the entry crosssection. The field strength near the belt cabling was typically 4-12 dB less than that measured at a similar distance away from the AC power cable. The belt and power cable were always on the left side of the entry when facing away from the transmitter. The left rib-to-right rib decrease in field strength in the main haulage entries was typically 25-35 dB.

Considering overall coverage of the haulage entry, both over the entry crosssection and along the entry, the best frequency of those measured was 910 KHz. Although the mapping at 2890 KHz was restricted in extent, the mapping indicated a more rapid fall-off of field strength with distance away from the transmitter than was experienced at 910 KHz. The 71 KHz field strength, although adequate along the main haulageways, did not extend into the 4-Butt section in the Noth Main at measurable levels.

3.0 EXPERIMENTAL APPROACH

The transmitter(s) was set up at the beltway junction of the North and South Mains. Measurements were performed by two teams; one team following a traverse along the North Main and the other team following a traverse along the South Main. Measurements along each traverse were repeated with each change in transmit frequency. Four transmit frequencies were used; 71,225,910, and 2890 KHz. Each traverse was taken generally along the belt entry (which also contained the track, AC power cable, phone line, and periodically the water line) with occasional excursions, when practical, into the adjacent right-hand entry. In addition, the North Main traverse included excursions into the belt entries of the 2-Butt and 4-Butt sections.

The locations along each traverse at which measurements were made are shown on the mine map introduced in Section 1 as Figure 1-1.

Measurement locations were established roughly every 6 crosscuts along the belt entries. Typical entry crosssectional physical geometries for measurement locations in the North and South Mains are given in Figure 3-1. At locations along the North Main traverse, measurements were generally made from left-to-right across the belt entry referenced to facing away from the transmitter. Measurements at most locations (proceeding from left-to-right) included:

- (1) AC power cable to the left of the belt, suspended from the roof and just away from the left rib
- (2) along the belt cabling adjacent to and to the right of the belt
- (3) at the track center
- (4) in the crosscut along the belt entry right rib plane
- (5) in the crosscut, near the right-hand barrier (stopping)

At locations along the South Main traverse, measurements were generally made from left-to-right (also as observed facing away from the transmitter).

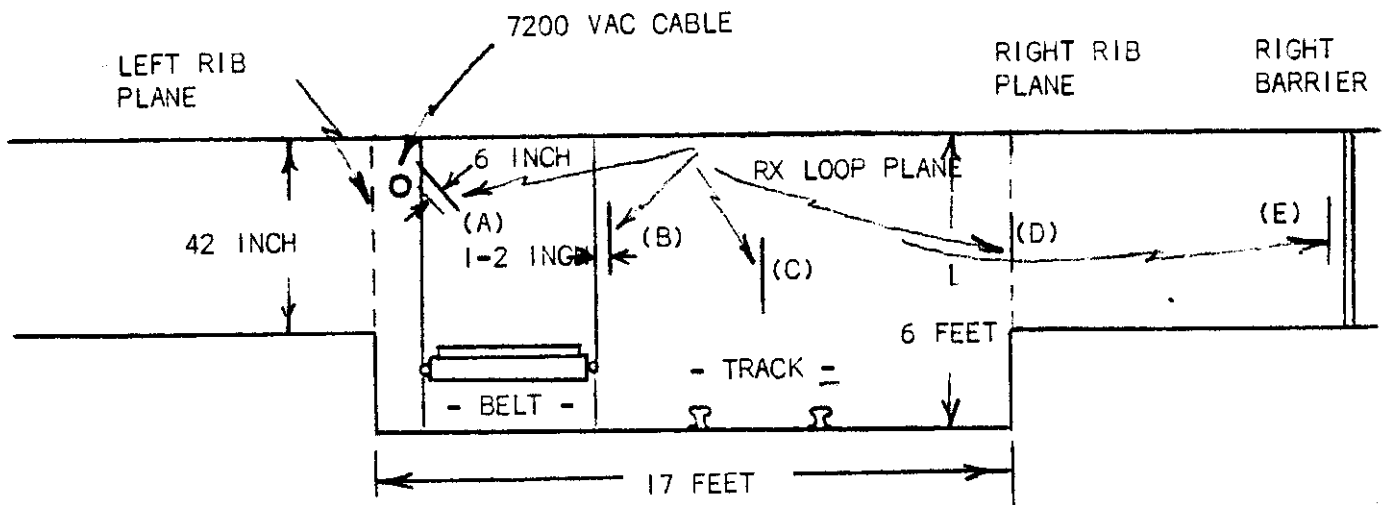

NORTH MAINS MEASURING POINTS (A), (B), (C), (D), (E)
 SOUTH MAINS MEASURING POINTS (B), (D), (E)

FIGURE 3-1
 MAIN HAULAGE ENTRY CROSSSECTIONS GEOMETRY FOR MEASUREMENTS

Measurements at most locations included:

- (1) along the belt cabling adjacent to and to the right of the belt
- (2) in the crosscut along the belt entry right rib plane
- (3) in the crosscut, near the right-hand barrier.

Most measurements were performed with the receive antenna orientation in the HMD position with the loop antenna plane being parallel to the entry direction (or to the belt or power cable, etc.). Typical proximity of the receiving loops to the belt and power cables are illustrated in Figure 3-1.

The multi-turn transmit antennas were each, in turn, tightly coupled to the AC power cable located in the South Main portion of the beltway junction. The transmit antennas were oriented HMD. At 71 KHz, the transmitter consisted of a Pyott Boone portable trolley phone (with self-contained battery) and a special 10-turn antenna. The transmit NIA was 7.43. This 71 KHz set-up is illustrated in Figure 3-2. At each of the higher frequencies, the transmit equipment set-up was the same as that developed for use during the Propagation of EM Signals in Underground Mines, contract H0366028. This latter test set-up is illustrated in Figure 3-3.

The raw data and the reduced data have been compiled and are given in the Appendix to this report, with annotations. The majority of the reduced data has been used in the preparation of magnetic field strength coverage maps at each of the four frequencies.

The magnetic field strength coverage maps are given as Figures 3-4 through 3-7.

It should be mentioned that these maps portray the magnetic field strength, propagated largely via mine wiring, from this transmit location, to the extent made possible within the limitations of the measurement points.

Coverage not shown, for example, along several of the North Main butt sections means that measurements were not made in these sections. Also, while the field strength in entries parallel to the measured main haulage entries can be expected to fall off monotonically with increasing distance perpendicular to the haulage entries when no conductors are present, the presence of conductors in these entries will enhance the coverage.

The transmitter location, while perhaps advantageously located, produces results that may be typical for a base station located elsewhere in the region near the main portal if equally tightly coupled to the power cable.

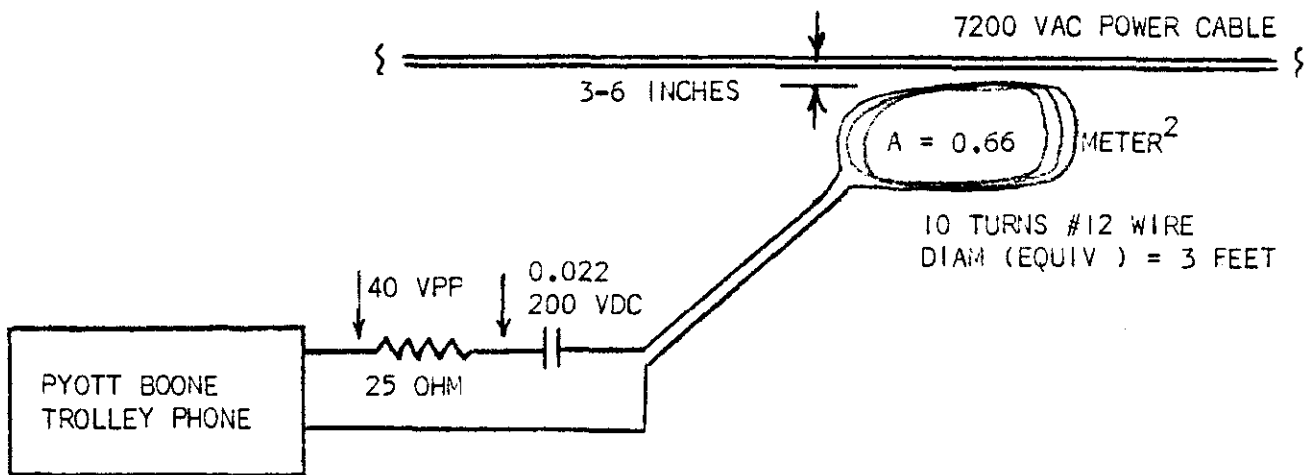

$$\text{RMS CURRENT} = \frac{0.707(40)}{25} = 1.13 \text{ AMP}$$

$$\text{NIA} = 7.43$$

$$7.46$$

FIGURE 3-2
TRANSMITTER EQUIPMENT USED FOR 71 KHZ

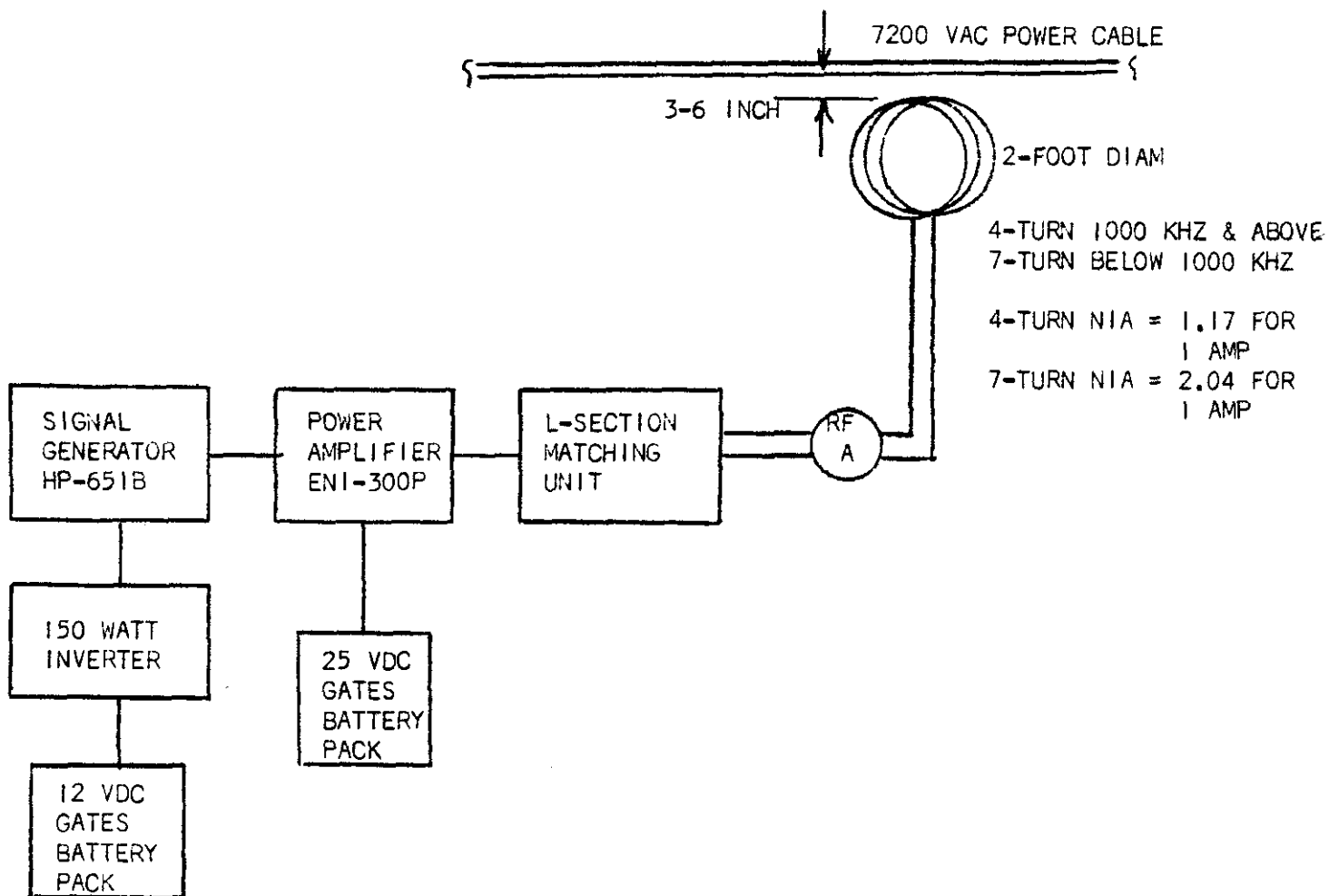

FIGURE 3-3
 TRANSMITTER EQUIPMENT USED FOR 225, 910, AND 2890 KHZ

10 DB CONTOUR INTERVAL

SCALE: 1 INCH =

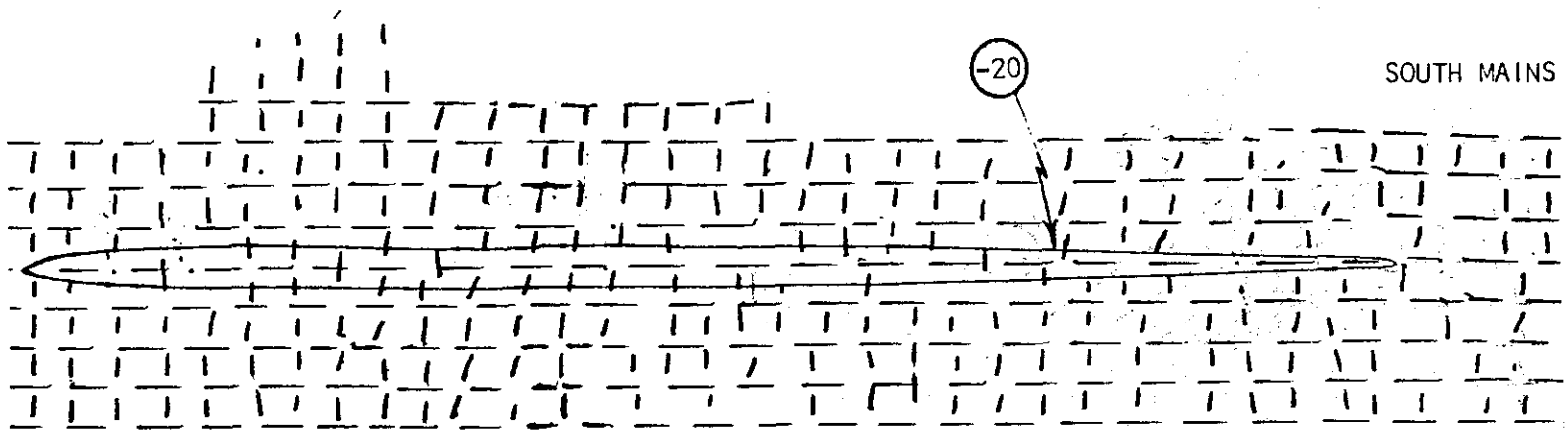
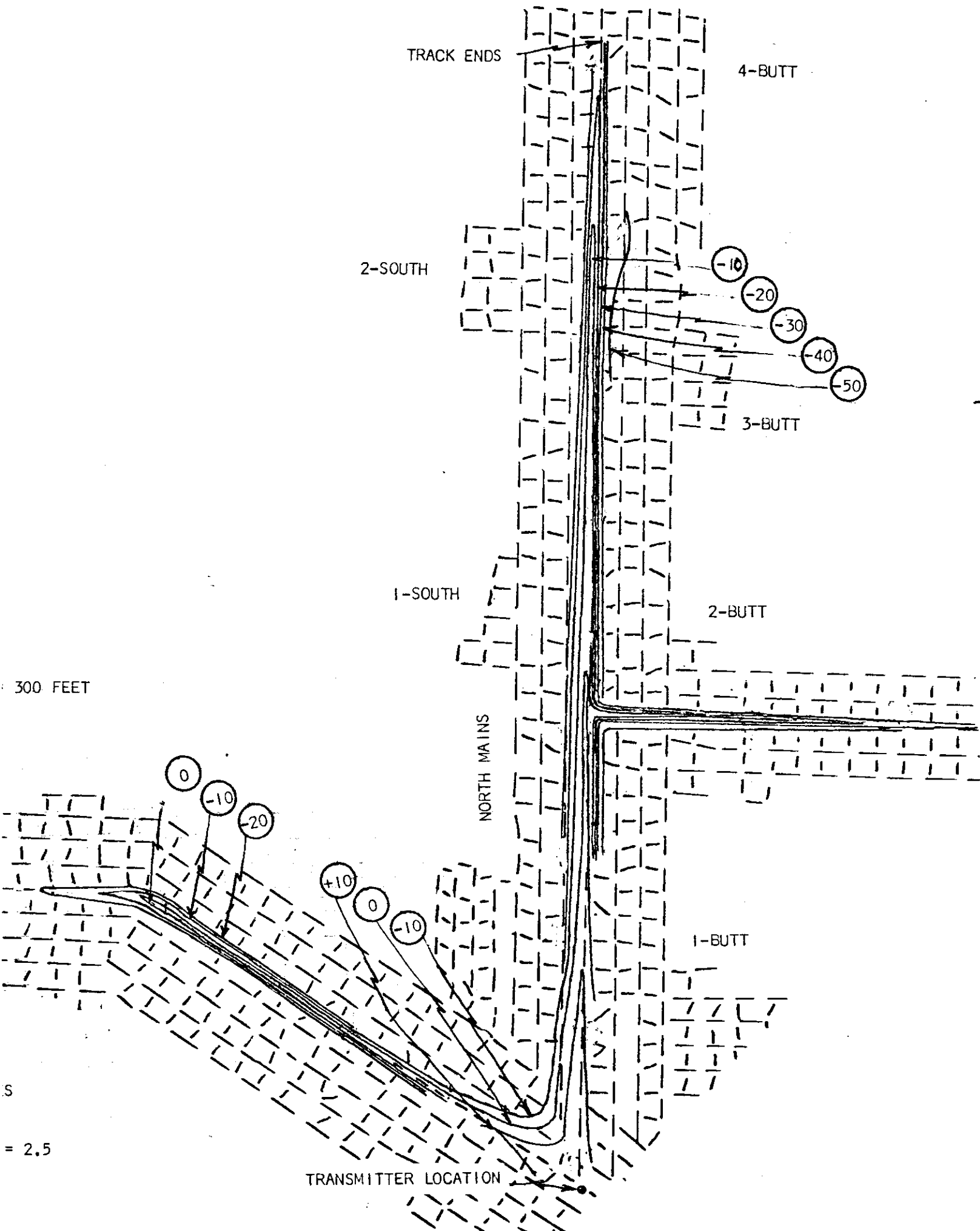

FIGURE 3-4

MAGNETIC FIELD STRENGTH COVERAGE MAP OF LUCERNE #8 MINE WITH THE TRANSMITTER PLACED
ADJACENT TO THE POWER CABLE AT THE JUNCTION OF THE NORTH AND SOUTH MAINS BELT ENTRIES
71 KHZ
MAGNETIC FIELD STRENGTH GIVEN IN DB GREATER THAN 1 MICROAMP PER METER, TRANSMIT NIA



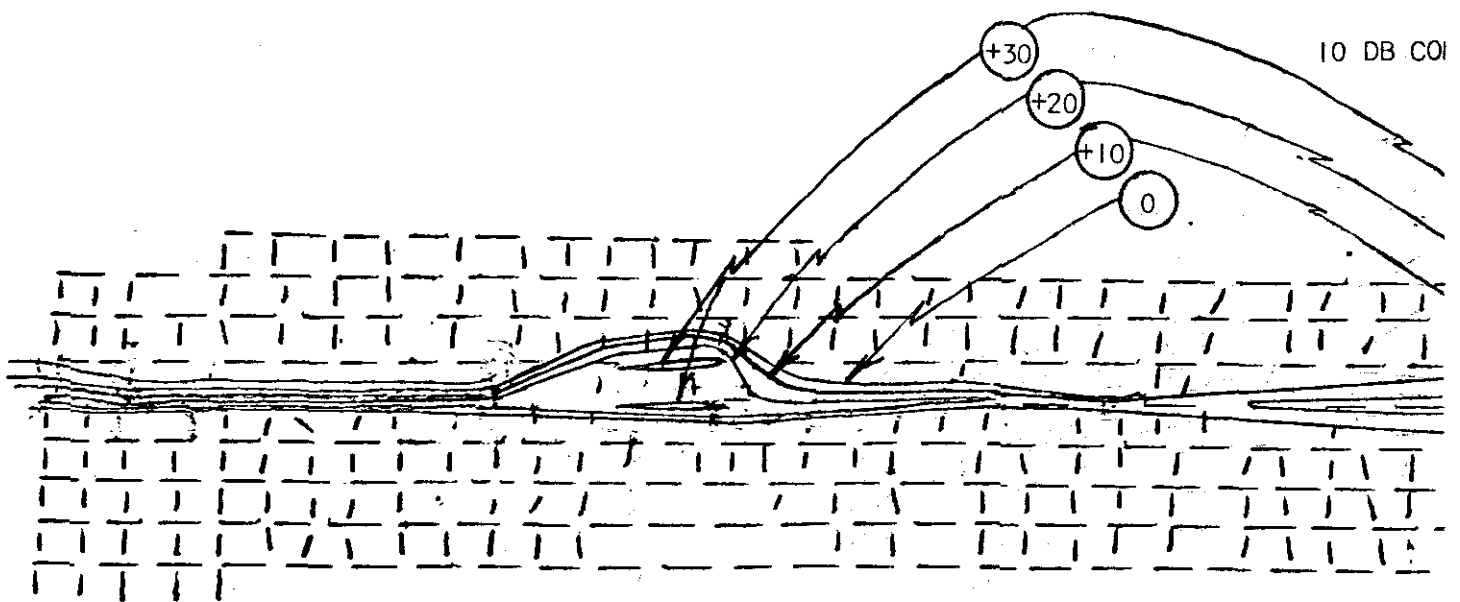
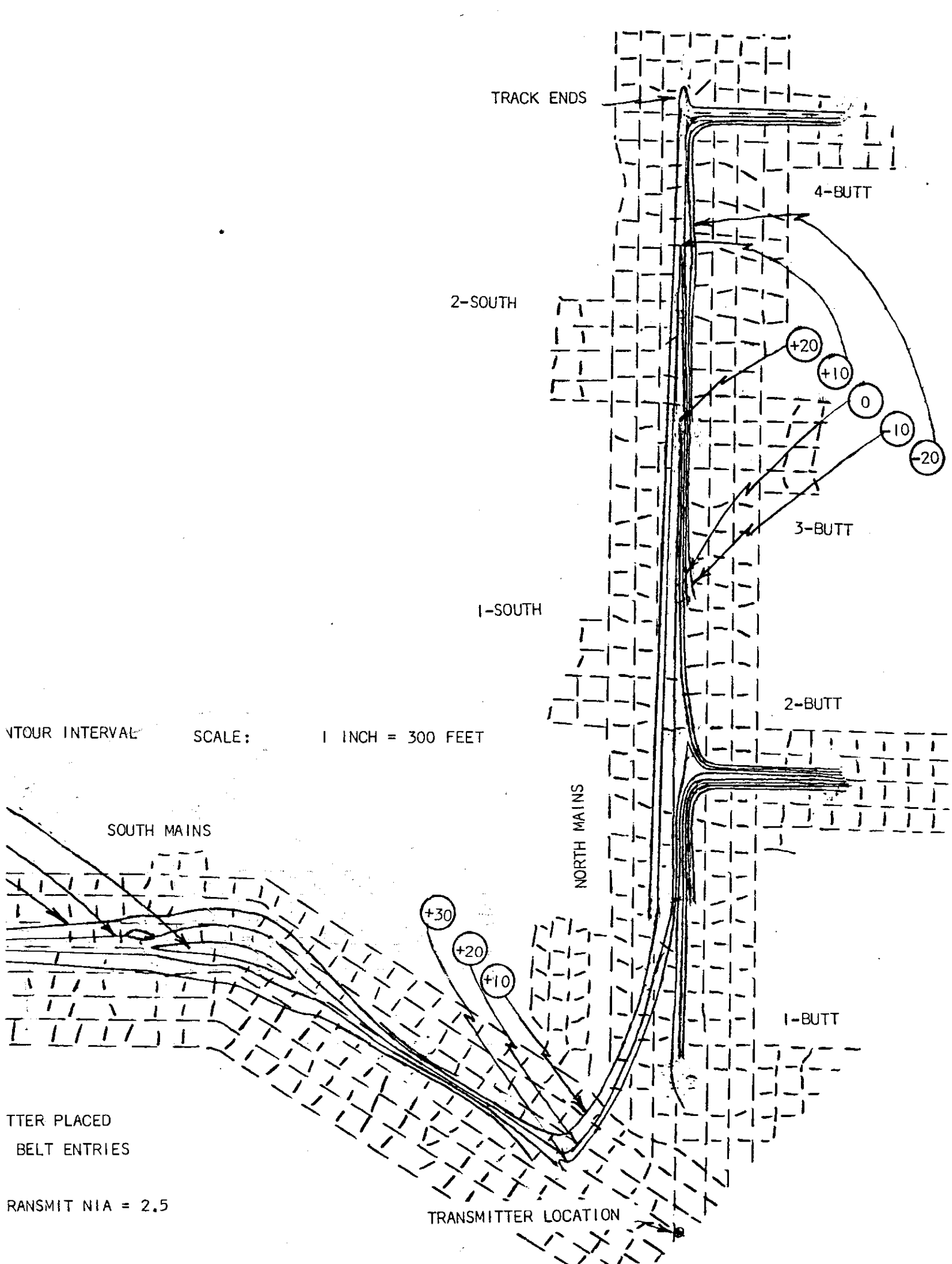

FIGURE 3-5
 MAGNETIC FIELD STRENGTH COVERAGE MAP OF LUCERNE #8 MINE WITH THE TRANSMI
 ADJACENT TO THE POWER CABLE AT THE JUNCTION OF THE NORTH AND SOUTH MAINS
 225 KHZ
 MAGNETIC FIELD STRENGTH GIVEN IN DB GREATER THAN 1 MICROAMP PER METER, T



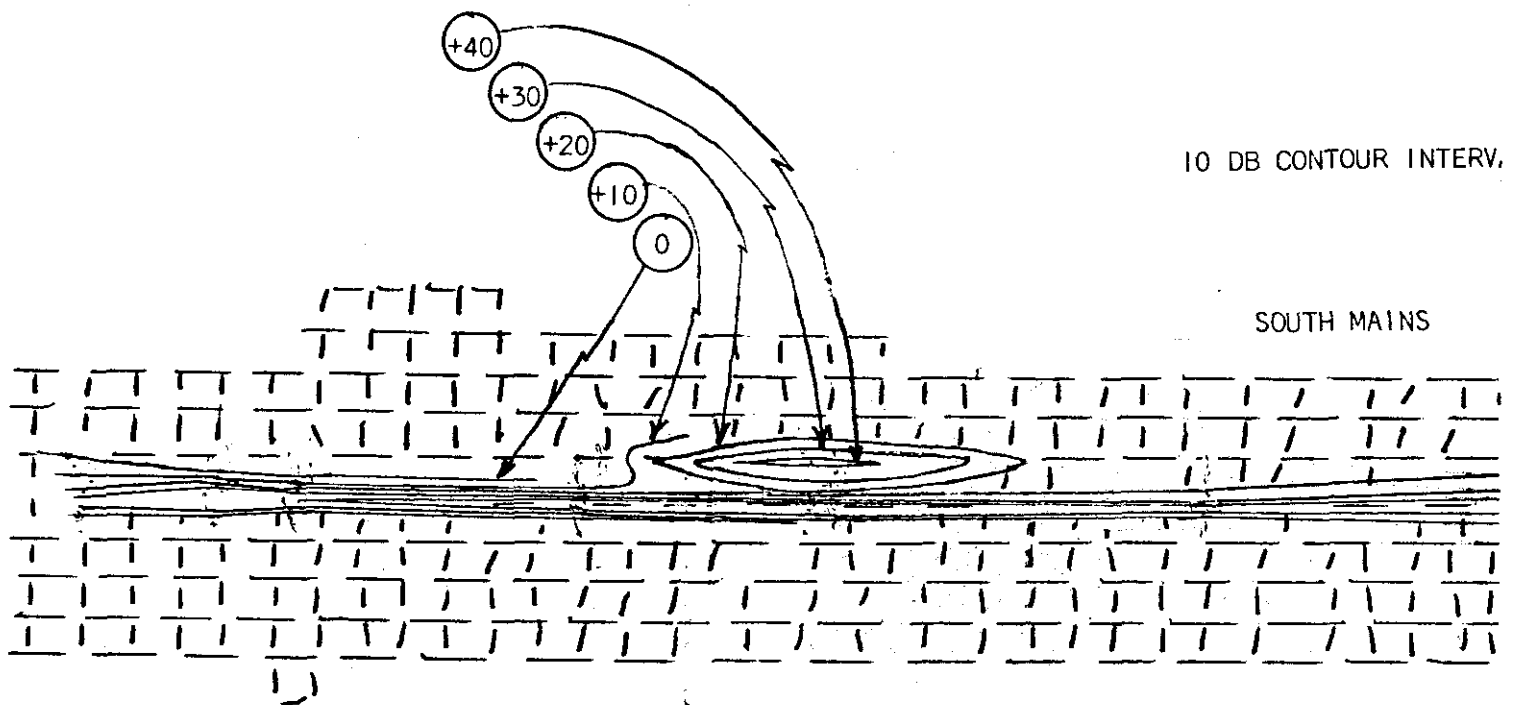
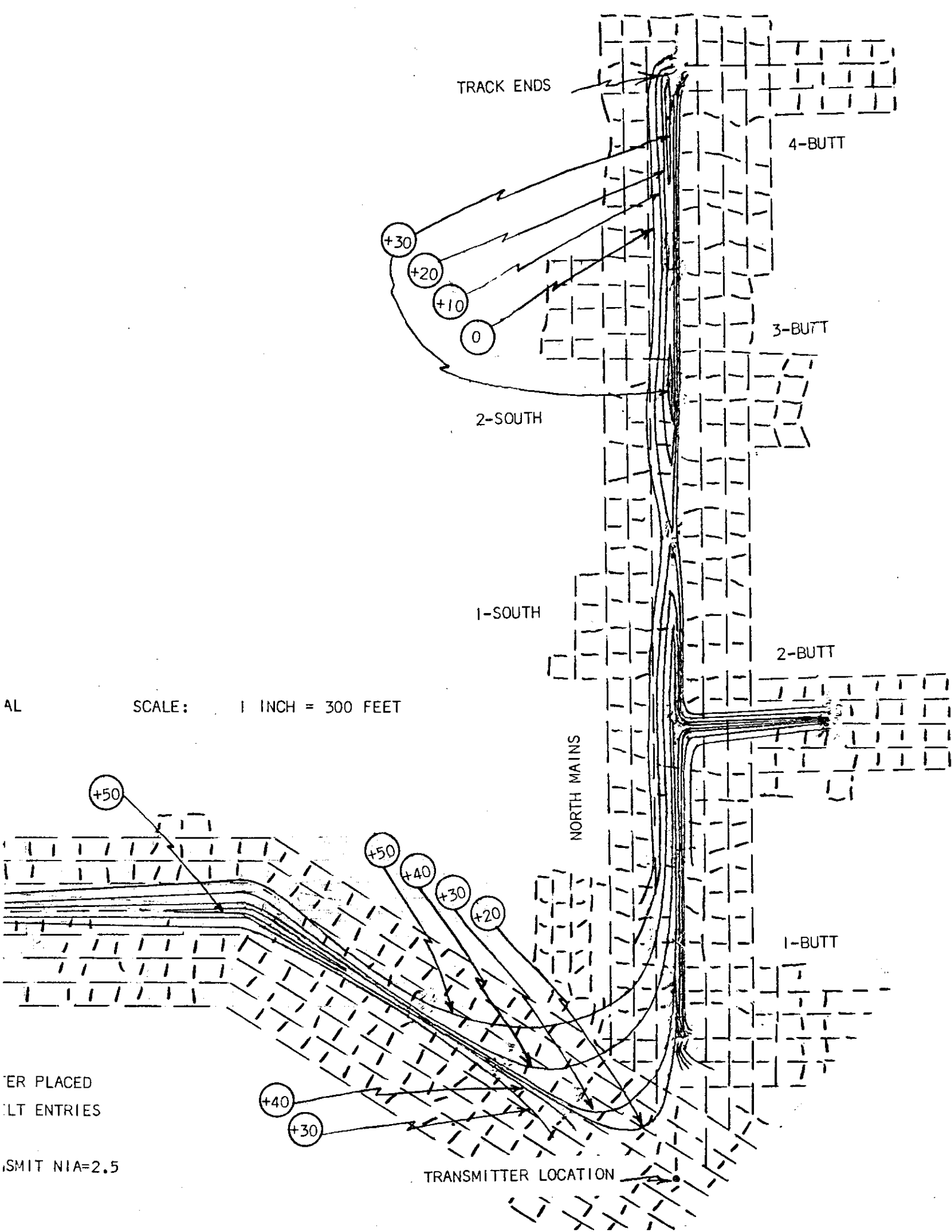

FIGURE 3-6
 MAGNETIC FIELD STRENGTH COVERAGE MAP OF LUCERNE #8 MINE WITH THE TRANSMITTER
 ADJACENT TO THE POWER CABLE AT THE JUNCTION OF THE NORTH AND SOUTH MAINS BE
 910 KHZ
 MAGNETIC FIELD STRENGTH GIVEN IN DB GREATER THAN 1 MICROAMP PER METER, TRANSMITTER



TRACK ENDS

4-BUTT

+30

+20

+10

0

3-BUTT

2-SOUTH

1-SOUTH

2-BUTT

SCALE: 1 INCH = 300 FEET

NORTH MAINS

1-BUTT

+50

+50

+40

+30

+20

+40

+30

TRANSMITTER LOCATION

ER PLACED
LT ENTRIES

SMIT NIA=2.5

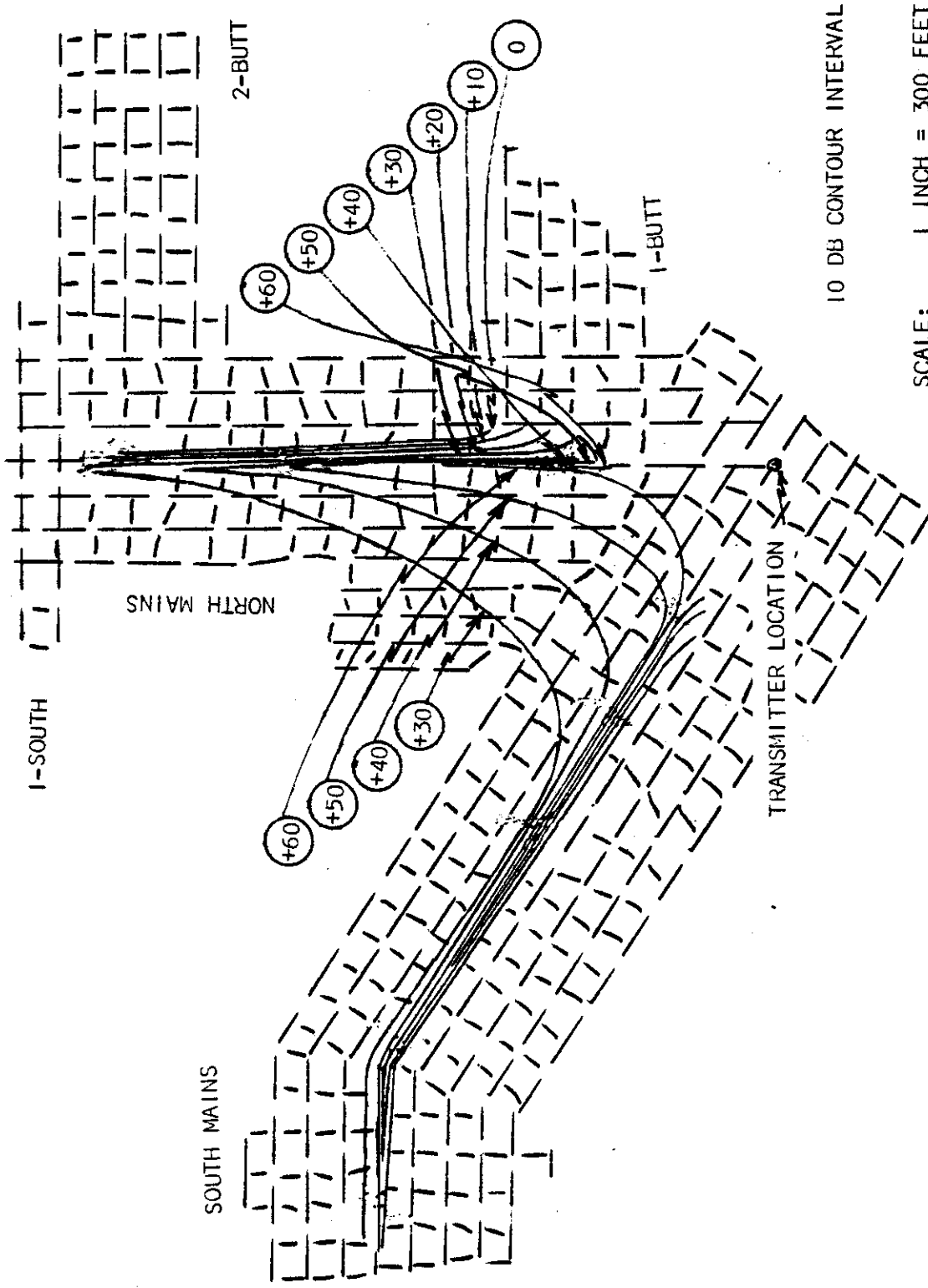

FIGURE 3-7

MAGNETIC FIELD STRENGTH COVERAGE MAP OF LUCERNE #8 MINE WITH THE TRANSMITTER PLACED ADJACENT TO THE POWER CABLE AT THE JUNCTION OF THE NORTH AND SOUTH MAINS BELT ENTRIES

2890 KHZ

MAGNETIC FIELD STRENGTH GIVEN IN DB GREATER THAN 1 MICROAMP PER METER, TRANSMIT NIA = 2.5

4.0 DATA REDUCTION TECHNIQUES

The NM-12 and NM-25 field strength meters have been calibrated so that a known incident field strength will produce readings of +25 dB and +10 dB respectively on the instrument panel meters with the attenuator in the -20 dB position. This known incident field strength is in terms of microvolts/meter (the plane wave equivalent electric field). As the calibration was actually performed using loop antennas, the true H calibration field strength is given by dividing the equivalent electric field strength by 377 ohms.

The calibration equivalent electric field strengths used to reduce the data presented in this report were:

<u>RX ANTENNA BAND SET #</u>	<u>FREQUENCY KHZ</u>	<u>FIELD STRENGTH MICROVOLTS/M</u>
3 low freq tuner	71	103
1 high " "	225	71
2 " " "	910	34.9
4 " " "	2890	13.5

In reducing the field strength data the field strength at each location in dB greater than 1 microamp/meter was found as the sum of the reading as determined in dB minus the field strength meter calibration point in dB plus the attenuation range setting plus 20 dB Plus the calibration field strength in dB greater than 1 microamp/meter plus the NIA normalization factor. In equation form, this is expressed as

$$\text{Field Strength} = \text{analog meter reading} - \begin{matrix} 10 \text{ for NM-25} \\ 25 \text{ for NM-12} \end{matrix} + \text{attenuator range setting} + 20 + \text{calibration field strength} + 20 \log_{10} \left(\frac{2.5}{\text{Tx current} \times \text{Tx ant NIA}} \right)$$

$$\text{Tx ant NIA} = \begin{matrix} 7.43 \text{ for Pyott Boone system} \\ 2.04 \text{ for 7-turn loop below 1000 KHz} \\ 1.17 \text{ for 4-turn loop above 1000 KHz} \end{matrix}$$

The reduced field strength values corresponding to each frequency were plotted on an overlay paper on a 1 inch = 200 feet scale mine map having the measurement points previously located. Field strength contours were plotted based on the distribution of data points and previous experience. The map overlays were reduced to a scale of 1 inch = 300 feet for presentation in this report using Xerographic techniques.

- APPENDIX -

RAW AND REDUCED DATA FROM THE LUCERNE #8 MINE TESTING

THE RAW DATA CONSISTS OF MAGNETIC FIELD STRENGTH TAKEN WITH THE NM-12 OR NM-25 FIELD STRENGTH METERS UNCORRECTED FOR THE INSTRUMENT CALIBRATION AND NIA NORMALIZATION FACTORS. CORRESPONDING TO EACH READING, THE REDUCED MAGNETIC FIELD STRENGTH IN DB GREATER THAN 1 MICROAMP PER METER IS GIVEN EMPLOYING THE DATA REDUCTION TECHNIQUE DESCRIBED IN SECTION 4 OF THE REPORT.

TEST #1 71 KHZ WITH 1.13 AMP INTO TX ANTENNA (NIA = 7.43) RX ANTENNA BAND 3 USING LOW FREQUENCY TUNER, REDUCED DATA NORMALIZED TO NIA = 2.5

SOUTH MAINS TAG LOCATION	ADJACENT TO BELT		RIGHT RIB		
	RAW DATA	REDUCED DATA	RAW DATA	REDUCED DATA	
53	+11 +20	+5.3			
77	+ 8 +20	+2.3	+ 8 0		-17.7
89	+ 7 +20	+1.3	+ 6 0		-19.7
110	+12 +20	+6.3			
132	+ 6 0	-19.7			
169	+23 -20	-22.7			
228	+10 0	-15.7			
306	+ 7 0	-18.7			
358	+27 -20	-18.7	+20 -20		-25.7 NEXT ENTRY OVER ENTRY CENTER LOC/847
?	+ 6 0	-19.7			

NORTH MAINS

STATION	RAW DATA	REDUCED DATA	NOTES
1	+23 +20	+17.3	TRACK CENTER
3	+13 +20	+ 7.3	ADJACENT TO BELT (1 FOOT AWAY)
	+19 0	- 6.7	TRACK CENTER
	+11½ -20	-34.2	AGAINST RIGHT BARRIER
2	+12 +20	+ 6.3	UNIFORM OVER AREA, JUNCTION OF I-BUTT NEAR BELT
4	+24 0	- 1.7	UNIFORM OVER JUNCTION
5	+24 0	- 1.7	1 FOOT FROM BELT
	+15 0	-10.7	TRACK CENTER

NORTH MAINS(CONT.)

<u>STATION</u>	<u>RAW DATA</u>	<u>REDUCED DATA</u>	<u>NOTES</u>
6	+20 0	- 5.7	1 FOOT FROM BELT
	+13 0	-12.7	TRACK CENTER
	+12 -20	-33.7	RIGHT RIB PLANE
	+18 -40	-47.7	RIGHT BARRIER (25 FEET AWAY)
	+12 -40	-44.2	NOISE @ RIGHT BARRIER
7	+23 0	- 2.7	1 FOOT FROM BELT
	+13 0	-12.7	TRACK CENTER
	+18 -20	-27.7	RIGHT RIB PLANE
	+24 -40	-41.7	RIGH T BARRIER (15 FEET AWAY)
	+16 -40	-49.7	NEXT ENTRY RIGHT, LEFT RIB PLANE
	+16 -40	-49.7	NEXT ENTRY RIGHT, RIGHT RIB PLANE VMD; HMD SIGNAL IN NOISE
	+13½ -40	-52.2	NEXT ENTRY OVER, RIGHT BARRIER (25 FEET AWAY), VMD, ½ DB ABOVE NOISE
8	+20 0	+ 3.8	NOISE UNIFORM OVER JUNCTION, NO SIGNAL, JUNCTION OF BELT DRIVE AND END OF TRACK
	+13 -20	-23.2	NOISE 40 FEET AWAY FROM END OF TRACK
7½	+24 -20	-21.7	TRACK CENTER
9	+18 0	+ 1.8	NOISE @ TRACK CENTER, NO SIGNAL
	+23 0	+ 6.8	NOISE OVER BELT, EQUIDISTANT BETWEEN POWER CABLE AND PHONE LINE
7½	+13 0	- 3.2	NOISE, NO SIGNAL, LEFT OF BELT ALONG LEFT RIB "FLAT" SIDE OF CABLE, 6 INCH FROM POWER CABLE
7	+10½ 0	-15.2	LEFT OF BELT ALONG LEFT RIB @CABLE
6	+16½ 0	- 9.2	LEFT OF BELT ALONG LEFT RIB @CABLE
5	+17 0	- 8.7	LEFT OF BELT ALONG LEFT RIB @CABLE
4	+25 0	- 0.7	LEFT OF BELT ALONG LEFT RIB @CABLE
10	+22 0	- 3.7	6 INCHES FROM WATER LINE & PHONE LINE RUNNING ALONG RIGHT OF BELT TOWARD ENTRY CENTER
	+ 6½ 0	-19.2	TRACK CENTER
	+ 7 -20	-38.7	RIGHT RIB PLANE, HMD
	+12 -20	-33.7	RIGHT RIB PLANE, HMD/VMD (45 DEG TILT)
	+21 -40	-44.7	RIGHT BARRIER

NORTH MAINS(CONT.)

<u>STATION</u>	<u>RAW DATA</u>		<u>REDUCED DATA</u>	<u>NOTES</u>
11	+29	-40	-36.7	TRACK CENTER
	+15	-40	-41.2	NOISE @ TRACK CENTER
	+22	-20	-23.7	LEFT @ BARRIER
	+25	-20	-20.7	AT POWER CABLE CROSSING AT RIGHT ANGLE TO POWER CENTER
3	+ 6	+20	+ 0.3	LEFT OF BELT ALONG LEFT RIB @CABLE
12	+18	-20	-27.7	VMD, ENTRY ENTER
	+ 8	-20	-37.7	HMD, ENTRY CENTER
13	+24	-20	-21.7	ENTRY CENTER
2	+ 8	+40	+27.3	LEFT OF BELT ALONG LEFT RIB @CABLE

TEST #2 225 KHZ WITH 0.76 AMP INTO TX ANTENNA (NIA = 1.55) RX ANTENNA BAND 1
 USING HIGH FREQUENCY TUNER, REDUCED DATA NORMALIZED TO NIA = 2.5,
 NM-12'S USED FOR THIS TEST

SOUTH MAINS

<u>TAG</u> <u>LOCATION</u>	<u>ADJACENT TO BELT</u>			<u>RIGHT RIB</u>			<u>RIGHT BARRIER</u>		
	<u>RAW DATA</u>	<u>REDUCED DATA</u>	<u>REDUCED DATA</u>	<u>RAW DATA</u>	<u>REDUCED DATA</u>	<u>REDUCED DATA</u>	<u>RAW DATA</u>	<u>REDUCED DATA</u>	<u>REDUCED DATA</u>
51	+27	+20	+31.6	+18	+20	+22.6			
68	+18	+20	+22.6	+ 9	+20	+13.6			
76	+20	+20	+24.6	+ 6	+20	+10.6	+25	-20	-10.4
110	+35	+20	+39.6	+30	+20	+34.6			
132	+25	+20	+29.6	+15	+20	+19.6	+19	+20	+23.6
277	+14	+20	+18.6	+15	0	- 0.4			
335	+25	+20	+29.6	+15	+20	+19.6	+15	+20	+19.6
	EXTRA DATA POINT, CENTER OF NEXT RIGHT ENTRY. LOTS OF CONDUCTOR AND TRACKS								
				+25	+20	+29.6			
387	+17	+20	+21.6	+19	0	+ 3.6	+ 7	0	- 8.4
446	+35	0	+19.6	+13	0	- 2.4	+ 6	0	- 9.4
476	+25	+20	+29.6	+21	0	+ 5.6	+ 7	0	- 8.4
493	+20	+20	+24.6	+20	0	+ 4.6	+23	-20	-12.4
							LOOSE RAILS TOSSED ABOUT		

NORTH MAINS

<u>STATION</u>	<u>RAW DATA</u>	<u>REDUCED DATA</u>	<u>NOTES</u>
2	+14 +60	+58.6	LEFT OF BELT @ POWER CABLE
	+30 +20	+34.6	HELD TO BUTT, BELT
	+ 8 +40	+32.6	1 INCH LEFT OF BELT
	+16 +20	+20.6	TRACK CENTER
	+ 7 +20	+11.6	RIGHT RIB
13	+20 +20	+24.6	ENTRY CENTER
12	+18½ 0	+ 3.1	ENTRY CENTER, VMD
3	+ 3 +40	+27.6	LEFT OF BELT @ POWER CABLE
	+14 +40	+38.6	ADJACENT TO & RIGHT OF BELT
	+ 1 +40	+25.6	TRACK CENTER
	+ 9 +20	+13.6	RIGHT RIB PLANE
	+14 0	- 1.4	RIGHT BARRIER
4	+ 9 +40	+33.6	LEFT OF BELT @ POWER CABLE
	+21 +20	+25.6	ADJACENT TO & RIGHT OF BELT
	+22 +20	+26.6	TRACK CENTER
	+26 +20	+30.6	RIGHT RIB PLANE. PERPENDICULAR TO CABLE @ POWER CENTER
	+15 +40	+39.6	PARALLEL TO & 6 INCHES AWAY FROM CABLE
5	+15 +20	+19.6	LEFT OF BELT @ POWER CABLE
	+15 +20	+19.6	ADJACENT TO & RIGHT OF BELT
	+ 7 +20	+11.6	TRACK CENTER
	+12 0	- 3.4	RIGHT RIB PLANE
	+ 5 0	-10.4	RIGHT BARRIER (10 FEET AWAY)
6	+15 +20	+19.6	LEFT OF BELT @ POWER CABLE
	+ 6 +20	+10.6	ADJACENT TO & RIGHT OF BELT
	+14 0	- 1.4	TRACK CENTER
	+16 -20	-19.4	RIGHT RIB PLANE
	+12 -20	-23.4	RIGHT BARRIER (25 FEET AWAY)
7	+11 +20	+15.6	LEFT OF BELT @ POWER CABLE
	+ 5 +20	+ 9.6	ADJACENT TO & RIGHT OF BELT
	+18 0	+ 2.6	TRACK CENTER
	+ 4 0	-11.4	RIGHT RIB PLANE

NORTH MAINS (CONT.)

<u>STATION</u>	<u>RAW DATA</u>		<u>REDUCED DATA</u>		<u>NOTES</u>
8	+ 4	+20	+ 8.6		LEFT OF BELT @ POWER CABLE
	+ 3	+20	+ 7.6		ADJACENT TO & RIGHT OF BELT
	+12	0	- 3.4		TRACK CENTER (BETWEEN TWO JEEPD)
	+ 3	0	-12.4		POWER STATION TRANSFORMER
	+ 4	-20	-31.4		1 ENTRY PAST 8 AND END OF TRACK
9	+17	0	+ 1.6		LEFT OF BELT @ LOWER CABLE
	+23	0	+ 7.6		ADJACENT TO & RIGHT OF BELT
	+13	0	- 2.4		TRACK CENTER
	+14	-20	-21.4		LEFT RIB PLANE
	+ 8	-20	-27.4		RIGHT BARRIER
10	+ 4	+40	+28.6		LEFT OF BELT @ POWER CABLE
	+ 6	+40	+30.6		ADJACENT TO & RIGHT OF BELT
	+13	+20	+17.6		TRACK CENTER
	+17	0	+ 1.6		LEFT RIB PLANE
	+10	0	- 5.4		RIGHT BARRIER

TEST #3 910 KHZ WITH 1.0 AMP INTO TX ANTENNA (NIA = 1.17) RX ANTENNA BAND 2
 USING HIGH FREQUENCY TUNER, REDUCED DATA NORMALIZED TO NIA = 2.5

SOUTH MAINS

<u>TAG</u>	<u>ADJACENT TO BELT</u>		<u>RIGHT RIB</u>			<u>RIGHT BARRIER</u>			
<u>LOCATION</u>	<u>RAW DATA</u>	<u>REDUCED DATA</u>	<u>RAW DATA</u>	<u>REDUCED DATA</u>	<u>RAW DATA</u>	<u>REDUCED DATA</u>	<u>RAW DATA</u>	<u>REDUCED DATA</u>	
51	+16	+40	+51.9	+25	+20	+40.9			
68	+15	+40	+50.9	+19	+20	+34.9			
76	+12	+40	+47.9	+15	+20	+30.9	+ 9	+20	+24.9
110	+20	+40	+55.9	+24	+20	+39.9			
277	+27	+20	+42.9	+10	+20	+25.9			
335	+13	+40	+48.9	+22	0	+17.9	+35	0	+30.9
	EXTRA DATA POINT, CENTER OF NEXT RIGHT ENTRY								
				+27	+20	+42.9			
387	+30	+20	+45.9	+25	0	+20.9	+25	-20	+ 0.9
446	+25	+20	+40.9	+10	+20	+25.9	+ 9	0	+ 4.9
476	+23	+20	+38.9	+22	+20	+37.9	+11	0	+ 6.9
507	+20	+20	+35.9	+ 7	+20	+22.9	+17	0	+12.9

NORTH MAINS

<u>STATION</u>	<u>RAW DATA</u>	<u>REDUCED DATA</u>	<u>NOTES</u>
2	+25 +40	+60.9	LEFT OF BELT @ POWER CABLE
	+13 +40	+48.9	ADJACENT TO & RIGHT OF BELT
	+17 +20	+32.9	TRACK CENTER
	+17 0	+12.9	RIGHT RIB PLANE
13	+ 5½ +20	+21.4	ENTRY CENTER
	+ 3½ 0	- 0.6	ENTRY CENTER, VMD
3	+20 +20	+35.9	LEFT OF BELT @ POWER CABLE
	+24 +20	+39.9	ADJACENT TO & RIGHT OF BELT
	+13 +20	+28.9	TRACK CENTER
	+14 0	+ 9.9	RIGHT RIB PLANE
	+ 8 0	+ 3.9	RIGHT BARRIER
10	+ 8 +20	+23.9	LEFT OF BELT @ POWER CABLE
	+15 +20	+30.9	ADJACENT TO & RIGHT OF BELT
	+ 3 +20	+18.9	TRACK CENTER
	+ 7 0	+ 2.9	RIGHT RIB PLANE, VMD
	0 0	- 4.1	RIGHT RIB PLANE, HMD
	0 0	- 4.1	RIGHT BARRIER
4	+26 +20	+41.9	LEFT OF BELT @ POWER CABLE
	+17 +20	+32.9	ADJACENT TO & RIGHT OF BELT
	+ 3 +20	+18.9	TRACK CENTER
	+ 8 0	+ 3.9	RIGHT RIB PLANE
5	+12 0	+ 7.9	LEFT OF BELT @ POWER CABLE
	+ 5 0	+ 0.9	ADJACENT TO & RIGHT OF BELT
	- 4 0	- 8.1	TRACK CENTER
NM-25 #2 WON'T WORK ON -20 DB SCALE			
6	+17 +20	+32.9	LEFT OF BELT @ POWER CABLE
	+10 +20	+25.9	ADJACENT TO & RIGHT OF BELT
	+17 0	+12.9	TRACK CENTER
	- 1 0	- 5.1	RIGHT RIB PLANE
7	+24 0	+19.9	LEFT OF BELT @ POWER CABLE
	+28 0	+23.9	ADJACENT TO AND RIGHT OF BELT
	+22 0	+17.9	TRACK CENTER
	+ 6 0	+ 1.9	RIGHT RIB PLANE

NORTH MAINS (CONT.)

<u>STATION</u>	<u>RAW DATA</u>		<u>REDUCED DATA</u>	<u>NOTES</u>
7½	+16	+20	+31.9	LEFT OF BELT @ POWER CABLE
	+13	+20	+28.9	ADJACENT TO & RIGHT OF BELT
	+ 4	+20	+19.9	TRACK CENTER
8	+10	0	+ 5.9	ENTRY CENTER BEYOND TRACK END

TEST #4 2890 KHZ WITH 0.3 AMP INTO TX ANTENNA (NIA = 0.35 0 RX ANTENNA BAND 4
USING HIGH FREQUENCY TUNER, REDUCED DATA NORMALIZED TO NIA = 2.5

SOUTH MAINS

<u>TAG LOCATION</u>	<u>ADJACENT TO BELT</u>			<u>RIGHT RIB</u>			<u>RIGHT BARRIER</u>		
	<u>RAW DATA</u>	<u>REDUCED DATA</u>		<u>RAW DATA</u>	<u>REDUCED DATA</u>		<u>RAW DATA</u>	<u>REDUCED DATA</u>	
51	+25	+40	+63.1	+15	+40	+53.1			
68	+25	+40	+63.1	+10	+40	+48.1			
76	+25	+40	+63.1	+ 7	+40	+45.1	+10	+20	+28.1
110	+15	+40	+53.1	+ 3	+40	+41.1			
132	+ 8	+40	+46.1	+18	+20	+36.1	+12	+20	+30.1

NORTH MAINS

<u>STATION</u>	<u>RAW DATA</u>		<u>REDUCED DATA</u>	<u>NOTES</u>
2	+18	+60	+76.1	LEFT OF BELT @ POWER CABLE
	+20	+40	+58.1	ADJACENT TO & RIGHT OF BELT
	+20	+20	+38.1	TRACK CENTER
	+17	+20	+35.1	RIGHT RIB PLANE
3	+11	+40	+49.1	LEFT OF BELT @ POWER CABLE
	+ 7	+40	+45.1	ADJACENT TO & RIGHT OF BELT
	+12	+20	+30.1	TRACK CENTER
	+18	0	+16.1	RIGHT RIB PLANE
4	+20	+20	+38.1	LEFT OF BELT @ POWER CABLE
	+16	+20	+34.1	ADJACENT TO & RIGHT OF BELT
	+ 3	+20	+21.1	TRACK CENTER
	+11	0	+ 9.1	RIGHT RIB PLANE