

IC

8621

Bureau of Mines Information Circular/ 1973

Methane Control in Eastern U.S. Coal Mines

**Proceedings of the Symposium of the Bureau
of Mines/Industry Technology Transfer Seminar,
Morgantown, W. Va., May 30-31, 1973**



UNITED STATES DEPARTMENT OF THE INTERIOR

Information Circular 8621

Methane Control in Eastern U.S. Coal Mines

**Proceedings of the Symposium of the Bureau
of Mines/Industry Technology Transfer Seminar,
Morgantown, W. Va., May 30-31, 1973**

**By Staff—Mining Research
Bureau of Mines, Washington, D.C.**



**UNITED STATES DEPARTMENT OF THE INTERIOR
Rogers C. B. Morton, Secretary**

**BUREAU OF MINES
John D. Morgan, Jr., Acting Director**

This publication has been cataloged as follows:

U.S. Bureau of Mines

Methane control in eastern U.S. coal mines. Proceedings of the symposium of the Bureau of Mines/Industry Technology Transfer Seminar, Morgantown, W. Va., May 30-31, 1973. [Washington] U.S. Bureau of Mines [1973]

96 p. illus., tables. (U.S. Bureau of Mines. Information circular 8621)

Includes bibliography.

1. Coal mines and mining—U.S.—Cong. 2. Methane—Congresses.
I. U.S. Bureau of Mines. II. Title. (Series)

TN23.U71 no. 8621 622.06173

U.S. Dept. of the Int. Library

CONTENTS

	<u>Page</u>
Abstract.....	1
Introduction.....	1
Acknowledgments.....	2
Welcome, by R. W. Van Dolah.....	3
Opening Remarks, by J. J. Yancik.....	4
Methane Control in U.S. Coal Mines--An Overview, by M. G. Zabetakis.....	9
Methane in Coal, by F. N. Kissell.....	18
Degasification Through Vertical Shafts, by H. H. Fields.....	25
The Use of Isolated Coal Panels in the Pittsburgh Coalbed, by C. Findlay, S. Krickovic, and J. E. Carpetta.....	39
Control of Methane by Water Infusion, by J. Cervik and A. Cetinbas.....	46
Degasification of a Coal Seam--Longwall Gob Area, by P. A. Ferguson.....	58
Gob Degasification Research--A Case History, by J. G. Davis and S. Krickovic.....	62
Degasification Through Vertical Boreholes, by M. Deul and C. H. Elder....	73
Panel discussion; panelists: J. Ashcraft, R. Dalzell, J. G. Davis, P. A. Ferguson, W. Laird, James Micheal, J. J. Yancik, and M. G. Zabetakis, moderator.....	82
Questions submitted after the seminar.....	91
Registration list.....	93

METHANE CONTROL IN EASTERN U.S. COAL MINES

Proceedings of the Symposium of the Bureau of Mines/Industry Technology
Transfer Seminar, Morgantown, W. Va., May 30-31, 1973

by

Staff—Mining Research

ABSTRACT

Research workers from the Bureau of Mines and industry met with other government and industry representatives at the Mont Chateau Lodge, Morgantown, W. Va., on May 30-31, 1973, to discuss the current status of methane control in eastern U.S. coal mines. The opening remarks, the eight technical presentations, and the discussions of the members of a government-industry panel are published here for the benefit of those concerned with the control of methane in coal mines. In addition, an introduction has been added to present the background of work in this field.

INTRODUCTION

The Bureau of Mines has been concerned with the control of methane in U.S. coal mines since it was established in 1910. The initial study¹ of this problem was actually begun in 1907 under the immediate supervision of Dr. J. A. Holmes, who subsequently became the first director of the Bureau of Mines. This study summarized the work of others in Europe and America as well as that of Darton in the laboratory and the flexed beds in the anthracite fields of Pennsylvania and in the nearby horizontal beds in Illinois. Briefly, Darton noted ". . . some of the causes of the variations in the character, amount, and pressure of such (explosive) gases are still unknown." Nevertheless, he concluded that the gas in coal is possibly ". . . locked in some loose chemical combination, dissolved as salt dissolves in water, or condensed as in porous charcoal, but undoubtedly it fills the pores and crevices in which it is condensed . . .;" further, "The pressure of water in the strata overlying coal beds is probably a factor of some importance in gas pressure . . ." He found that an average of about 1,500 cubic feet of methane were released per ton of anthracite mined in the Wilkes-Barre, Pa., area, but that quantities in excess of twice this figure were encountered. By contrast, he found that the deep mines in Illinois yielded 50 to 260 cubic feet per ton. After reviewing the European data, he concluded that, "The extension of boreholes horizontally in the coal bed or from the surface above is a promising expedient, but in most cases it does not draw much gas from solid coal because

¹Darton, N. H. Occurrence of Explosive Gases in Coal Mines. BuMines Bull. 72, 1915, 248 pp.

the surface exposed is too small and gas travels through the coal too slowly to affect a wide area." From his study of Pennsylvania mines he noted, "The mine operators have to use great precaution to insure complete ventilation in all working chambers of the mines . . .;" ". . . in the northern basin . . . the volume of air for ventilation is equal to about 341,000 cubic feet for every ton of coal mined." This is in excess of 12 tons of air per ton of coal, which is a large quantity of air even by today's standards, although some gassy mines now use twice this amount.

Others considered this problem in subsequent years, but little experimental work was conducted here until after World War II. Approximately 20 years ago, Spindler² published the first of a series of papers on methane control, and Venter and Stassen³ prepared their report at the request of the Bureau of Mines on the drainage and utilization of firedamp in Europe. Deul⁴ subsequently presented a survey paper in 1964 and proposed a systematic program that was undertaken by the Bureau and a number of cooperating coal companies. The results of the initial phase of this program were presented at a special meeting in Pittsburgh, Pa., on May 8, 1969. The present seminar should give an up-to-date account of the work being done in eastern U.S. coal mines and reiterate that many procedures are available for use in controlling methane before and after mining begins. The seminar itself is one in a series devoted to various aspects of mine safety and was sponsored by the Bureau of Mines Mining Technology Transfer group; arrangements for the seminar were made by Messrs. William Schmidt, Thomas J. Crocker, Donald E. Ralston, Milford L. Skow, and Michael G. Zabetakis.

ACKNOWLEDGMENTS

The Office of the Assistant Director--Mining and the Technology Transfer Group wish to express their appreciation to the speakers and the many people who helped with the seminar, especially to Dr. M. G. Zabetakis, then of the Pittsburgh Mining and Safety Research Center, now with the Mining Enforcement and Safety Administration, for arranging the program and proceedings and to Thomas J. Crocker, Spokane Mining Research Center, for making the necessary arrangements for the seminar.

²Spindler, G. R. Degasification of Coal Beds. Coal Mine Modernization, 1953, pp. 206-220.

³Venter, J., and P. Stassen. Drainage and Utilization of Firedamp. BuMines IC 7670, 1953, 22 pp.

⁴Deul, M. Methane Drainage From Coalbeds: A Program of Applied Research. Proc. 60th Meeting, Rocky Mountain Coal Min. Inst., June 30-July 1, 1964, Vail, Colo., 1964, pp. 54-60.

WELCOME

by

R. W. Van Dolah¹

I would like to welcome each of you to our first methane control seminar in the Technology Transfer Series. In the past, I have taken this opportunity to review the functions of the Pittsburgh Mining and Safety Research Center. But because we have a rather full schedule today I will instead extend an invitation to each of you to visit us in Pittsburgh and Bruceton, Pa., where we can show you firsthand what we are doing not only in the area of methane control and ventilation, but also in other areas of interest to the mining community.

We trust you will find today's program of interest and invite you to join us on the field trip scheduled as part of tomorrow's activities. You will be given more information on these trips later today. Without further ado, let me introduce our first speaker, who really needs no introduction, Dr. Yancik, Acting Assistant Director--Mining. Dr. Yancik will discuss the Bureau's program on methane control.

¹Research Director, Pittsburgh Mining and Safety Research Center, Bureau of Mines, Department of the Interior, Pittsburgh, Pa.

OPENING REMARKS

by

J. J. Yancik¹

I would like to welcome you here this morning to what we expect will be an interesting and very informative Technology Transfer Seminar on Methane Control in Eastern U.S. Coal Mines. While today's emphasis is on the technical presentations, we do hope that you will be able to accompany our researchers to the field tomorrow where you can see firsthand some of the technology discussed today. The purpose of this seminar is to provide the coal mining industry with detailed information about recently developed techniques, equipment, and instruments for degasifying or otherwise controlling gas in a coal bed. Techniques that you will hear described include degasification through vertical boreholes and shafts, isolation of panels, and water infusion. Also, degasification of caved areas through boreholes will be described.

Methane has been a problem in U.S. coal mines almost as long as underground mining has existed. The hazards associated with concentrations of methane are well known to all of us. An ignition of an accumulation of methane can result in a devastating explosion particularly when associated with coal mine dust. Coal miners and operators alike go to great pains and expense to maintain methane levels within safe limits in an attempt to eliminate the possibility of a coal mine disaster.

A recent survey made by the Bureau of Mines and published in IC 8558 titled "Methane Emission From U.S. Coal Mines," points out that some U.S. coal beds contain as much as 10 ft³ of methane per cubic foot of coal. A gassy mine producing 5,000 tpd of coal may liberate 5 million cfd of methane; several mines in the United States liberate in excess of 10 million cfd of methane. Regulations require methane to be diluted and carried safely outside in ventilating air and necessitate safeguards against sparks that could cause a gas ignition.

The record of disasters that have resulted from methane emission in underground coal mines is all too familiar in our minds. In fact, a series of methane explosions in 1907 in essence brought about the creation of the U.S. Bureau of Mines in 1910. The immediate effort has been directed toward preventing disasterous explosions through the promotion of safe mining practices,

¹Acting Assistant Director--Mining, Bureau of Mines, U.S. Department of the Interior, Washington, D.C.

approved mining equipment, and adequate ventilation; engineers, scientists, and coal miners have long sought methods of totally eliminating the problem. But the problem has not been simple. It is true that fatalities resulting from methane explosions have been greatly reduced, yet the fundamental problem still persists.

Figure 1 reflects the improvements made through the efforts of those involved in the industry to control explosions resulting from methane ignitions. The trend in fatalities related to explosions is most encouragingly downward. However, it must be recognized that methane is potentially an even more serious safety threat because of the need for higher productivity and the necessity to extract coal from deeper coalbeds. The trend could therefore reverse itself without improvement in control techniques and methodologies. Hence, increased productivity at deeper depths will not be possible without new, innovative, and acceptable control technologies.

The disaster in 1969 provided the impetus for Congress to pass the Coal Mine Health and Safety Act of 1969 which provided the additional funds necessary to continue and expand the methane control research program pursued by the Bureau. The current research program has these objectives: Predicting methane concentrations in coalbeds; establishing the geological conditions that contribute to abnormal methane concentrations in coalbeds; assessing the physical properties of coal and adjacent strata that influence the retention and emission of methane; studying the effect of coal extraction on the emission of methane; and devising and testing methods for effectively draining or controlling methane emissions from coalbeds prior to and during mining. These objectives have provided the basis for the methane control research efforts at the Bureau of Mines for some time. Degasification techniques as a means of controlling methane emission was started about 1963 as a part of the methane control research program being pursued by the Bureau.

An overall view of the methane control research program is shown graphically in figure 2. Selected applications of results from research efforts include a demonstration of water infusion techniques to reduce methane in face areas and the degasification of methane through vertical boreholes. Other applications of results are in process or are planned for the near future. Funding levels increased rapidly with passage of the Coal Mine Health and Safety Act and are presently at levels slightly lower than the high of 1971.

While the safeguarding of life is the immediate concern of measures to minimize the effects of methane emission, other benefits are also reaped. By providing improved means of degasifying coalbeds and removing methane from coalbeds prior to mining an operator can maintain or improve methane control while at the same time provide increased productivity, decreased ventilation costs, and perhaps dispose of the methane commercially and help contribute to the solution of the energy problem.

One of the major problems of moving newly developed technology from its laboratory and demonstration phases into active use by the industry is to show potential users the benefits that can be gained by incorporation of the new technology into their mining systems. To further this endeavor the Bureau has

INFLUENCE OF SAFETY RESEARCH

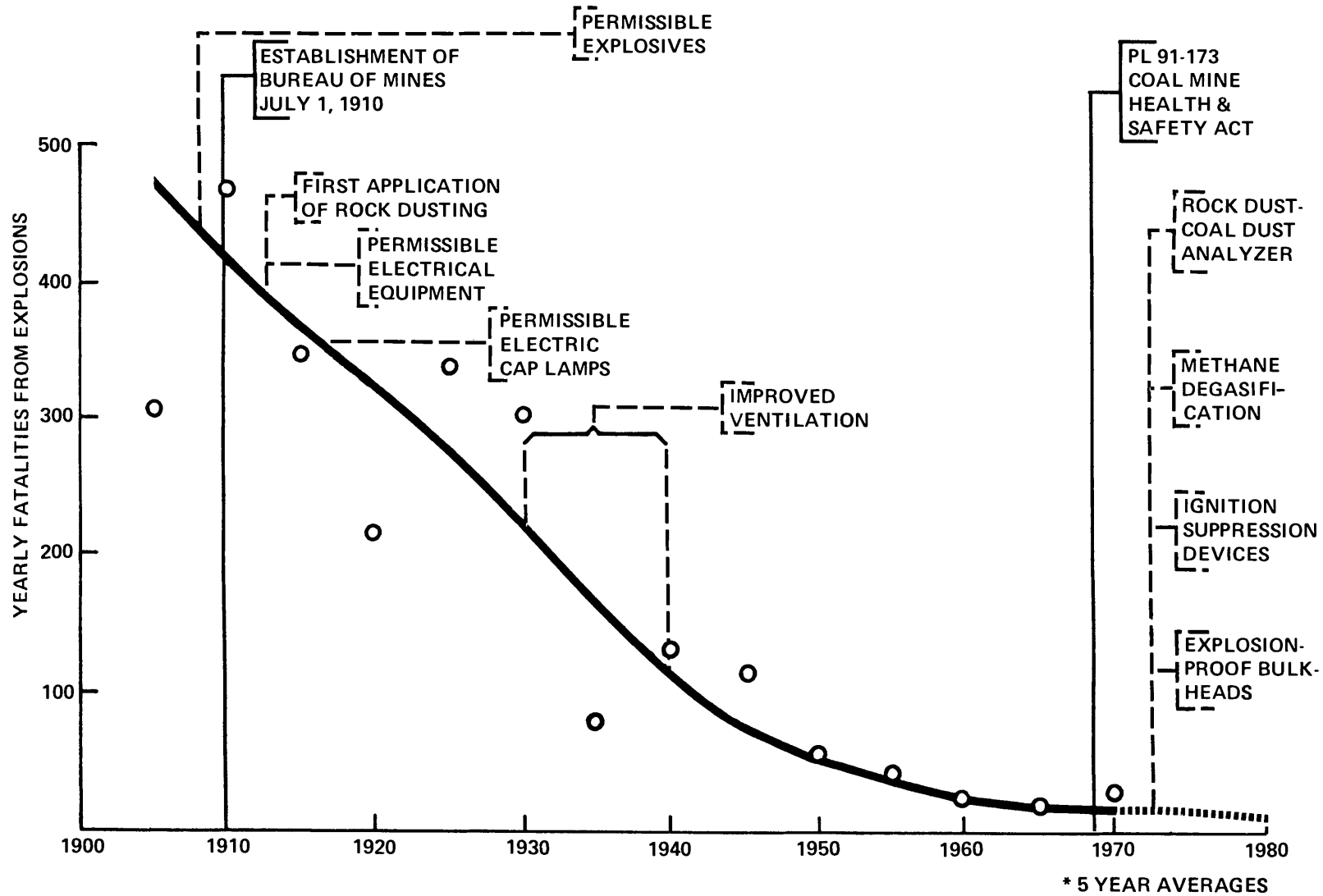

FIGURE 1. - Influence of safety research on deaths due to explosions.

METHANE CONTROL

OBJECTIVE:

DEVELOP TECHNOLOGY FOR SAFE MINING OF METHANE-LADEN COALBEDS.

STUDY AREAS:

- PREDICTIONS OF CONCENTRATIONS AND FLOW
- CONTROL IN ADVANCE OF MINING
- CONTROL DURING MINING

APPLICATION OF RESULTS:

- 1971: OIL WELL, WHICH PENETRATED PITTSBURGH COALBED, SAFELY PLUGGED AND MINED THROUGH IN COOPERATION WITH CHRISTOPHER COAL CO.
- 1972: WATER INFUSION TECHNIQUES USED TO REDUCE METHANE IN FACE AREA AT EASTERN ASSOCIATED COAL CO'S FEDERAL NO. 2 MINE, CONSOLIDATION COAL CO'S LOVERIDGE MINE, AND IN LAND CREEK COAL CO'S BEATRICE MINE.
- 1972: DEGASIFICATION THROUGH VERTICAL BOREHOLES DEMONSTRATED AT 10 LOCATIONS IN 8 COALBEDS.
- 1972 - 1974: SEVEN OIL AND GAS WELLS WHICH PENETRATE COALBEDS TO BE PLUGGED IN COOPERATION WITH AMAX COAL CO., AND SOUTHERN OHIO.
- 1973: COMPLETE DEGASIFICATION OF OPERATIONAL MINE TO BE CONDUCTED AT EASTERN ASSOCIATED COAL CO'S FEDERAL NO. 2.

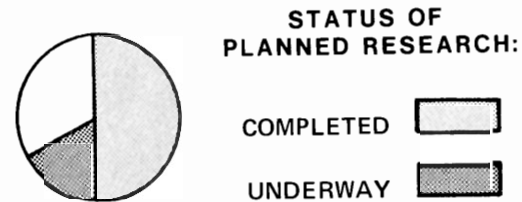
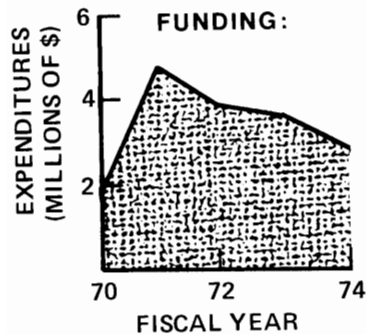

FIGURE 2. - Overall view of methane control program.

created a Technology Transfer Group to which is given the responsibility to assist in promoting the utilization of new technology. This seminar is but one of the ways we attempt to inform you and the industry of newly emerging technologies.

The techniques for improved methane control in underground mines that you will hear reported today are rigidly developed technologies and are ready for incorporation into the mines. You will have to make the judgment whether or not to incorporate these technologies into your mines. The technology is available to better and more effectively control methane emission. Our research personnel are prepared to offer to you the technical assistance relative to the adoption and/or adaption of these technologies into your particular mining system.

Progress to date in this methane control research program has largely been the result of successful cooperative research efforts with the industry. In fact, without this cooperative attitude as exhibited between the Bureau and coal companies, advances would not be nearly so successful. We will continue in the future to seek cooperative cost-sharing research efforts in order to advance even further the state-of-the-art and develop the technologies necessary to control methane.

Consequently, I invite you, in fact, I urge you to talk to our research people here today and tomorrow about your mining problems relative to methane control.

METHANE CONTROL IN U.S. COAL MINES--AN OVERVIEW

by

M. G. Zabetakis¹

ABSTRACT

Methane has been a problem in U.S. coal mines almost as long as underground mining has existed. This paper summarizes the procedures that have been used in the past to remove it and to dilute it to a safe level. In addition, the procedures currently being evaluated for use in assessing the magnitude of the methane problem as well as those now available for use in removing methane before and during mining are considered briefly. Examples are given of the results obtained in recent months in a number of U.S. mines.

INTRODUCTION

One of the primary goals of the Bureau of Mines is to decrease and, where possible, to eliminate the hazards associated with the mining of coal. In this connection, we have reexamined a potential problem area that has been associated with coal mining in this country for over 160 years--the presence of methane. Approximately one in eight deaths has been attributed to the ignition of methane and coal dust in the past 66 years in U.S. coal mines. Unfortunately, this ratio has increased in recent years, in spite of the fact that the frequency of occurrence of major mine explosions and the fatality rate associated with coal mining have both decreased (figs. 1-2) (39).² This may be due in part to the increased liberation rate of methane in today's mines. A recent study has shown that the methane emission rate (MER) depends on both the mine depth (D) and on the coal production rate (CPR) (14). Figure 3 gives a composite of the methane emission rate data for mines in the Pittsburgh, Pocahontas Nos. 3 and 4, and the Illinois Nos. 5 and 6 coalbeds. Based on the results in this figure, we can anticipate a further increase in methane emission rates as mining rates and depths increase, unless steps are taken to remove this gas before it enters the ventilation air. As noted in the subsequent papers in this series, this can be done before mining starts in a

¹Research Supervisor, Methane Control and Ventilation, Pittsburgh Mining and Safety Research Center, Bureau of Mines, U.S. Department of the Interior, Pittsburgh, Pa. Currently, supervisory physical scientist, Mining Enforcement and Safety Administration, Washington, D.C.

²Underlined numbers in parentheses refer to items in the bibliography at the end of this chapter.

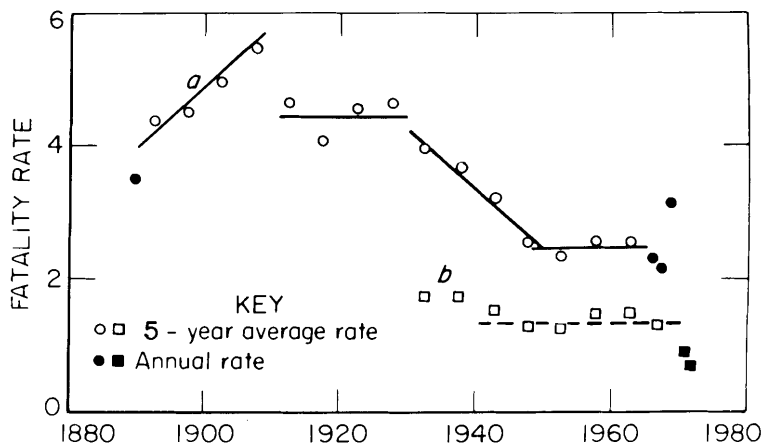

FIGURE 1. - U.S. coal mine fatality rate; *a*, per thousand 300-day workers and *b*, per million man-hours exposure.

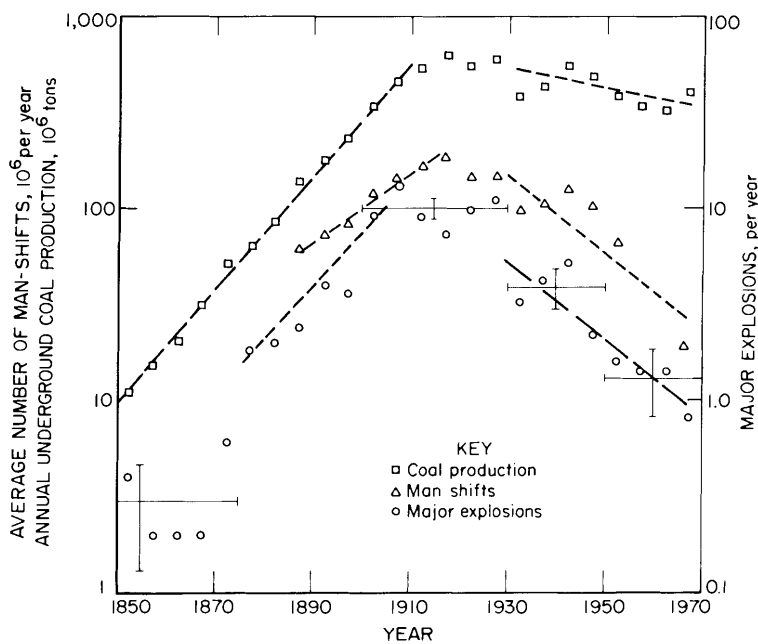

FIGURE 2. - Underground coal production, man-shifts, and major coal mine explosions in U.S. mines between 1850 and 1970 (5-year averages).

particular area or while mining is in progress. A consideration of the basic principles involved in this work should be made; a brief summary of the results obtained to date in the eastern coal mines will follow the next section.

BASIC PRINCIPLES

According to Mott (30), approximately 3,000 ft³ of methane is produced in forming 1 ton of a medium rank bituminous coal, along with copious quantities of carbon dioxide and water. Only a fraction of this gas is retained in our eastern coals; the balance being lost to the atmosphere. In practice, the amount of methane that has been retained by a particular coal is determined in part by the coal itself, the moisture content and temperature of the coal, and the hydrostatic pressure at the location at which the coal is located. Thus, if we assume that the gas pressure at a particular location is exactly equal to the hydrostatic head pressure, then we can write:

$$P = P_{gas} = P_{hyd} = 0.435h, \quad (1)$$

where *h* is the height of the water column above the coal. Knowing this pressure, we can then measure the amount of gas that would be adsorbed by a ton of coal at

a particular temperature. For example, Joubert (16) has found that the gas adsorbed by water-saturated coal in the Pittsburgh coalbed is given approximately by the equation:

$$V_{ad} = \frac{1.53P}{1+0.0039P} \text{ ft}^3/\text{ton}. \quad (2)$$

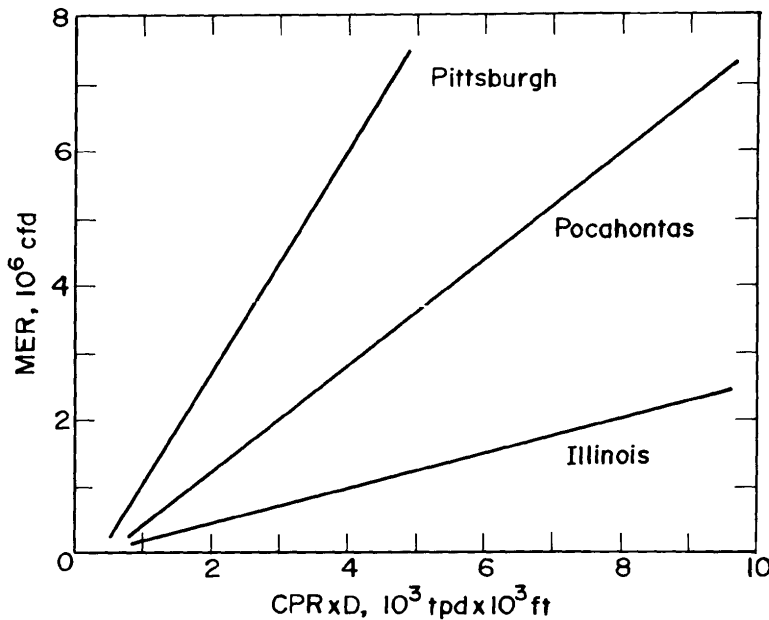

FIGURE 3. - Methane emission rate versus coal production rate times depth for mines in the Pittsburgh, Pocahontas Nos. 3 and 4, and Illinois Nos. 5 and 6 coalbeds.

Using equation 1, we can write this in terms of h . Thus we have:

$$V_{ad} = \frac{0.666h}{1+0.0017h} \text{ ft}^3/\text{ton}, \quad (3)$$

where h again represents the height of the water column above the coal. If we make the further assumption that h is essentially the height of the overburden, then we can determine the gas content of the coal at any location in the Pittsburgh coalbed. Unfortunately, several difficulties are encountered when we attempt to use equation 3. First, it is difficult to determine the actual overburden height in mountainous areas. Second, even when we know this height, we may not necessarily know the actual hydrostatic head. For example,

figure 4 gives the measured gas pressures as a function of well depth for a number of wells drilled into various coalbeds in the United States. This work is discussed in greater detail by Deul (6); for our present purposes, however, note that the gas pressure is actually below P_{hyd} in most cases, so that equation 3 would tend to overestimate V_{ad} . Nevertheless, this equation can serve as a first approximation if other data are not available. Finally, a comparison of the adsorbed gas volumes and the actual methane emission rates obtained from operating mines (fig. 3) shows that, as expected, emission rates are much higher. For example, using the data from mines in the Pittsburgh coalbed, the ratio of the methane liberation rate ($MLR = MER/CPR$) to V_{ad} is approximately 4 (fig. 5). Kissell (22) has studied this in some detail and found even larger ratios in many cases.

METHANE CONTROL IN THE UNITED STATES

Although the Bureau of Mines has been interested in methane control for a number of years, very little was done in this area, other than in the field of ventilation, until fairly recently. Approximately 20 years ago, J. Venter and P. Stassen, Institut National de l'Industrie Carbonniere, Belgium, prepared a paper on the drainage and utilization of firedamp in response to a request from the Bureau (37). During this period, Spindler, Poundstone, Merritts, and Ridenour (27-28, 32-34) initiated a series of investigations on the use of horizontal and vertical holes to remove methane from virgin coal and on the use of water to block it at active face areas. Following this early work,

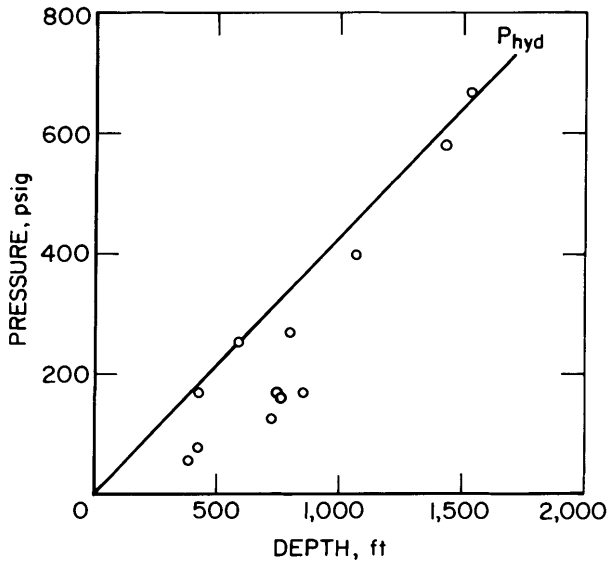

FIGURE 4. - Shut-in pressure versus well depth (h).

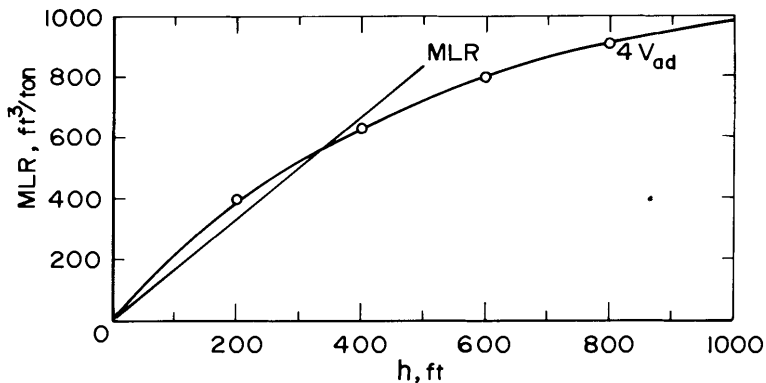

FIGURE 5. - Methane liberation rates and adsorbed gas volumes for mines in the Pittsburgh coalbed versus depth (h).

Spindler and Poundstone (34) noted that: "Horizontal drilling in advance of underground mining appears to offer the most promising prospect, but effective and extensive application will be dependent upon the ability to drill long holes . . ." Also, "Water infusion appears to offer some good prospects as an aid to degasification and in the control of gas liberation rates in producing sections and at working faces and should be investigated further."

A systematic study of methane control was initiated here about 10 years ago. The initial results of this work were presented at a seminar held in Pittsburgh, Pa., in 1969 (2, 7, 12-13, 25, 31). In recent months, additional studies have been

made by the Bureau and others on improved packers for use underground (5), the composition of coalbed gas (18-19), the movement of methane in coal (1, 20), the determination of the methane content of a coalbed from cores (22), degasification through vertical boreholes (6), degasification through horizontal holes (9-10), the use of isolated panels (11), the effects of geologic factors (15, 26), the effects of oil and gas wells (38), methane control by

water infusion (3-4), gob degasification through vertical boreholes (8, 29), the effects of bleeder systems (24), methane emission from operating mines (14, 23), and the ventilation of deep mines (17). This work has shown quite conclusively that many U.S. coalbeds can be successfully degasified before mining commences. We are now in the process of degasifying a producing mine in the Pittsburgh coalbed. Several phases of this work are discussed by Deul (6), Fields (9), Krickovic (23), and Cervik (3).

Finally, while all underground mines must be ventilated, other methane control techniques can be considered under the provisions of Section 301(b)

of the Federal Coal Mine Health and Safety Act and Section 75.316 of the mandatory safety standards in Title 30, U.S. Code of Federal Regulations (35-36). Rather than circulate the huge quantities of air encountered in many of the gassy mines (as much as 10 to 15 tons of air is circulated per ton of coal removed, in some cases), it would be desirable to remove the methane before mining commences. The procedures described here have been found effective in removing 20 to 80 percent of the methane that would ordinarily enter the ventilation air (fig. 6).

Methane control procedures should be incorporated in all phases of underground mining, beginning with the initial exploration and continuing until mining is completed. Many problems can be circumvented if the gas content of the coal is determined by measuring gas reservoir pressures and gas flow rates when boreholes are drilled during exploration, and by determining the gas content of the coal from coal cores (22). Alternatively, methane liberation rates can be estimated by studying the methane emission of other mines in the area operating in the same coalbed (14). We have recently proposed (39) that where the anticipated methane liberation rate approaches 400 cfm per ton of

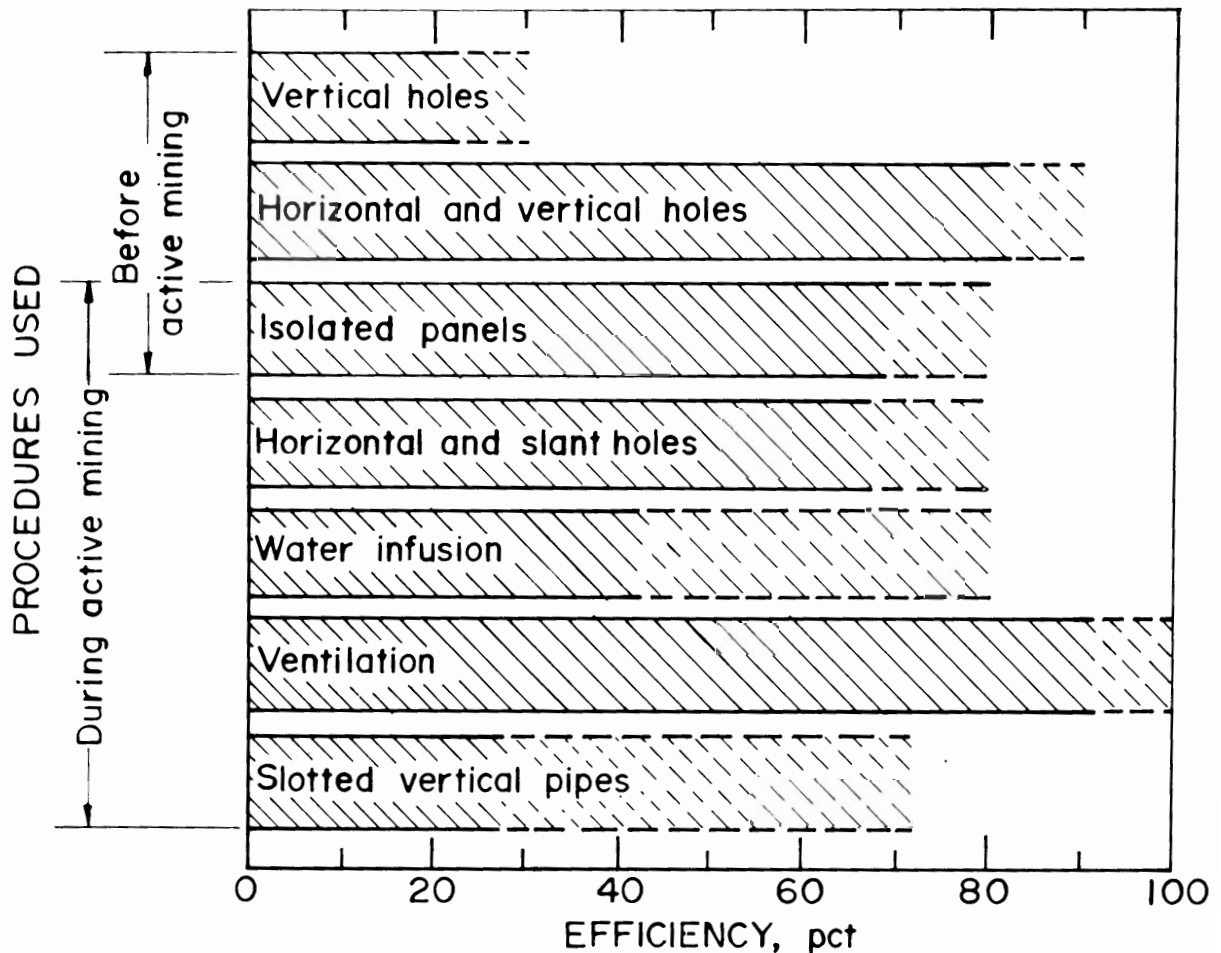

FIGURE 6. - Efficiencies of various methane control techniques in eastern U.S. coal mines.

coal mined, ventilation alone should be considered inadequate and that other methane control procedures should be utilized. This would include the use of vertical and horizontal holes to dewater and degasify an area before the onset of mining; the use of horizontal holes to infuse an active face area with water and thus divert the flow of methane; the use of long horizontal holes to dewater and degasify a section during mining; improvement of bleeder entries; the use of vertical holes and slotted pipes to drain a gob area; the outlining of isolated panels to degasify the panels prior to mining; hydrofracing a block of coal to increase its permeability; and rapid dilution of methane with air as it enters the mine. Detailed procedures can be found in a number of references included in the bibliography (39).

CONCLUSIONS

Methane control procedures must be utilized more extensively to prevent the anticipated increase in methane emission rates from underground mines as mining rates and depths increase. These should be incorporated in all phases of underground mining, beginning with the initial exploration and continuing until mining is completed.

BIBLIOGRAPHY

1. Bielicki, R. J., J. H. Perkins, and Fred N. Kissell. Methane Diffusion Parameters for Sized Coal Particles--A Measuring Apparatus and Some Preliminary Results. BuMines RI 7697, 1972, 12 pp.
 2. Cervik, Joseph. Behavior of Coal-Gas Reservoirs. BuMines TPR 10, 1969, 10 pp.
 3. Cervik, Joseph, and Abdurrahman Cetinbas. Control of Methane by Water Infusion. Pres. at Tech. Transfer Seminar on Methane Control in Eastern U.S. Coal Mines, Morgantown, W. Va., May 30-31, 1973, 35 pp.
 4. Cetinbas, Abdurrahman, R. P. Vinson, Joseph Cervik, and M. G. Zabetakis. Methane and Dust Control by Water Infusion. Pittsburgh Coalbed (Fairview, W. Va.). BuMines RI 7640, 1972, 17 pp.
 5. Cobbs, J. H., and J. D. Hadden. New Packer Helps Control Methane in Coal Mines. Coal Age, v. 78, No. 1, January 1973, pp. 60-62.
 6. Deul, Maurice, and C. H. Elder. Degasification Through Vertical Boreholes. Pres. at Tech. Transfer Seminar on Methane Control in Eastern U.S. Coal Mines, Morgantown, W. Va., May 30-31, 1973, 15 pp.
 7. Elder, C. H. Use of Vertical Boreholes for Assisting Ventilation of Longwall Gob Areas. BuMines TPR 13, 1969, 6 pp.
 8. Ferguson, Pete. Methane Control by Boreholes. Coal Age, v. 77, No. 1, January 1972, pp. 76-77.
 9. Fields, Herbert H. Degasification Through Vertical Shafts. Pres. at Tech. Transfer Seminar on Methane Control in Eastern U.S. Coal Mines, Morgantown, W. Va., May 30-31, 1973, 25 pp.
 10. Fields, H. H., Stephen Krickovic, Albert Sainato, and M. G. Zabetakis. Degasification of Virgin Pittsburgh Coalbed Through a Large Borehole. BuMines RI 7800, 1973, 26 pp.
 11. Findlay, Charles. Private communication, 1973. Available upon request from Stephen Krockovic, Pittsburgh, Pa.
 12. Hadden, J. D., and Joseph Cervik. Design and Development of Drill Equipment. BuMines TPR 11, 1969, 11 pp.
 13. Hadden, J. D., and Albert Sainato. Gas Migration Characteristics of Coalbeds. BuMines TPR 12, 1969, 10 pp.
 14. Irani, M. C., E. D. Thimons, T. G. Bobick, Maurice Deul, and M. G. Zabetakis. Methane Emission From U.S. Coal Mines. A Survey. BuMines IC 8558, 1972, 58 pp.
-

15. Jeran, P. W., and J. R. Mashey. A Computer Program for the Stereographic Analysis of Coal Fractures and Cleats. BuMines IC 8454, 1970, 34 pp.
16. Joubert, James I. Private communication, 1972. Available upon request from James I. Joubert, Pittsburgh, Pa.
17. Kalasky, J. D. Ventilation of Deep Coal Mines. Min. Cong. J., v. 58, No. 9, September 1972, pp. 43-48.
18. Kim, Ann G. The Composition of Coalbed Gas. BuMines RI 7762, 1973, 9 pp.
19. Kim, A. G., and L. J. Douglas. Gases Desorbed From Five Coals of Low Gas Content. BuMines RI 7768, 1973, 9 pp.
20. Kissell, Fred N. The Methane Migration and Storage Characteristics of the Pittsburgh, Pocahontas No. 3, and Oklahoma Hartshorne Coalbeds. BuMines RI 7667, 1972, 22 pp.
21. Kissell, Fred N., and R. J. Bielicki. An In Situ Diffusion Parameter for the Pittsburgh and Pocahontas No. 3 Coalbeds. BuMines RI 7668, 1972, 13 pp.
22. Kissell, F. N., C. M. McCulloch, and C. H. Elder. The Direct Method of Determining Methane Content of Coalbeds for Ventilation Design. BuMines RI 7767, 1973, 17 pp.
23. Krickovic, Stephen, and Charles Findlay. Methane Emission Rate Studies in a Central Pennsylvania Mine. BuMines RI 7591, 1971, 9 pp.
24. Krickovic, Stephen. Private communication, 1973. Available upon request from Stephen Krickovic, Pittsburgh, Pa.
25. LaScola, J. C., and Joseph Cervik. Development of Recording Methanometers and Recording Anemometers for Use in Underground Coal Mines. BuMines TPR 15, 1969, 17 pp.
26. McCulloch, C. M., and Maurice Deul. Some Geologic Factors That Cause Roof Instability, Methane Emission, and Water Control Problems in Mines in the Lower Kittanning Coalbed, Cambria County, Pa. BuMines RI 7769, 1973, 25 pp.
27. Merritts, W. M., W. N. Poundstone, and B. A. Light. Removing Methane (Degasification) From the Pittsburgh Coalbed in Northern West Virginia. BuMines RI 5977, 1962, 39 pp.
28. Merritts, W. M., C. R. Waine, L. P. Mokwa, and M. J. Ackerman. Removing Methane (Degasification) From the Pocahontas No. 4 Coalbed in Southern West Virginia. BuMines RI 6326, 1963, 39 pp.
29. Moore, T. D., Jr., and M. G. Zabetakis. Effect of a Surface Borehole on Longwall Gob Degasification (Pocahontas No. 3 Coalbed). BuMines RI 7657, 1972, 9 pp.

30. Mott, R. A. The Origin and Composition of Coals. Fuel in Science and Practice, v. 22, No. 1, 1943, pp. 20-26.
 31. Perkins, J. H., and Joseph Cervik. Sorption Investigations of Methane on Coal. BuMines TPR 14, 1969, 6 pp.
 32. Ridenour, D. C. Core Drilling of Air Shafts and Manway Portals. Min. Cong. J., v. 43, October 1957, pp. 99-101.
 33. _____. Ventilation by Large-Diameter Boreholes. Mechanization, March 1959, pp. 69-70.
 34. Spindler, G. R., and W. N. Poundstone. Experimental Work in the Degasification of the Pittsburgh Coal Seam by Horizontal and Vertical Drilling. Trans. AIME, v. 220, 1961, pp. 37-46.
 35. U.S. Code of Federal Regulations. Title 30--Mineral Resources; Chapter I--Bureau of Mines, Department of the Interior; Subchapter O--Coal Mine Health and Safety; Part 75--Mandatory Safety Standards, Underground Coal Mines. Federal Register, v. 35, No. 226, Nov. 20, 1970, pp. 17890-17929.
 36. U.S. Congress. Federal Coal Mine Health and Safety Act of 1969. Public Law 91-173, Dec. 30, 1969, 83 Stat. 742.
 37. Venter, J., and P. Stassen. Drainage and Utilization of Firedamp. BuMines IC 7670, 1953, 22 pp.
 38. Zabetakis, M. G., T. D. Moore, Jr., A. E. Nagel, and J. E. Carpetta. Methane Emission in Coal Mines--Effects of Oil and Gas Wells. BuMines RI 7658, 1972, 9 pp.
 39. Zabetakis, M. G., Maurice Deul, and M. L. Skow. Methane Control in United States Coal Mines--1972. BuMines IC 8600, 1973, 23 pp.
-

METHANE IN COAL

by

F. N. Kissell¹

ABSTRACT

Recent Bureau of Mines research on methane movement through coalbeds has provided some insight into the major factors that govern the rate and manner by which methane is released into coal mines. Emissions from the solid working face and from broken coal are reviewed. The vital role of interstitial water is discussed. A method to predict approximately the gassiness of a prospective mine from exploration cores is presented.

INTRODUCTION

This morning, we will consider first some of the factors that govern the flow of methane underground. I do not think it is necessary to discuss how the methane got in the coal in the first place. Nor is it necessary to belabor the fact that a gassy coal mine can release some remarkable quantities of methane. Rather, I think it might be better for us to look at the problem in terms of a number of questions a practical mining man might ask the researcher to answer. Here are three:

(1) Where does most of the methane come from during mining at the face? Does it come from deep within the coalbed? From coal at the face? From broken coal? From the roof and floor?

(2) Why is so much gas given off from broken coal?

(3) Why are some sections of a mine gassier than others?

These are all practical questions about methane which I think our basic research program has substantially answered and which I hope to answer for you today.

¹Physical research scientist, Pittsburgh Mining and Safety Research Center, Bureau of Mines, U.S. Department of the Interior, Pittsburgh, Pa.

FUNDAMENTAL FACTORS

The Bureau started its present methane research program by drilling holes and measuring gas pressures in the solid coal adjacent to the working face area. Figure 1 shows how two such holes might have been drilled. Typically they were 3 in. in diameter, and perpendicular to the rib. After drilling, they were sealed with inflatable packers and the gas pressure was measured. In general, higher pressures were found in hole No. 2 because the rib at this point had had less time to drain gas than that at hole No. 1; note that hole No. 2 is closer to the working face.

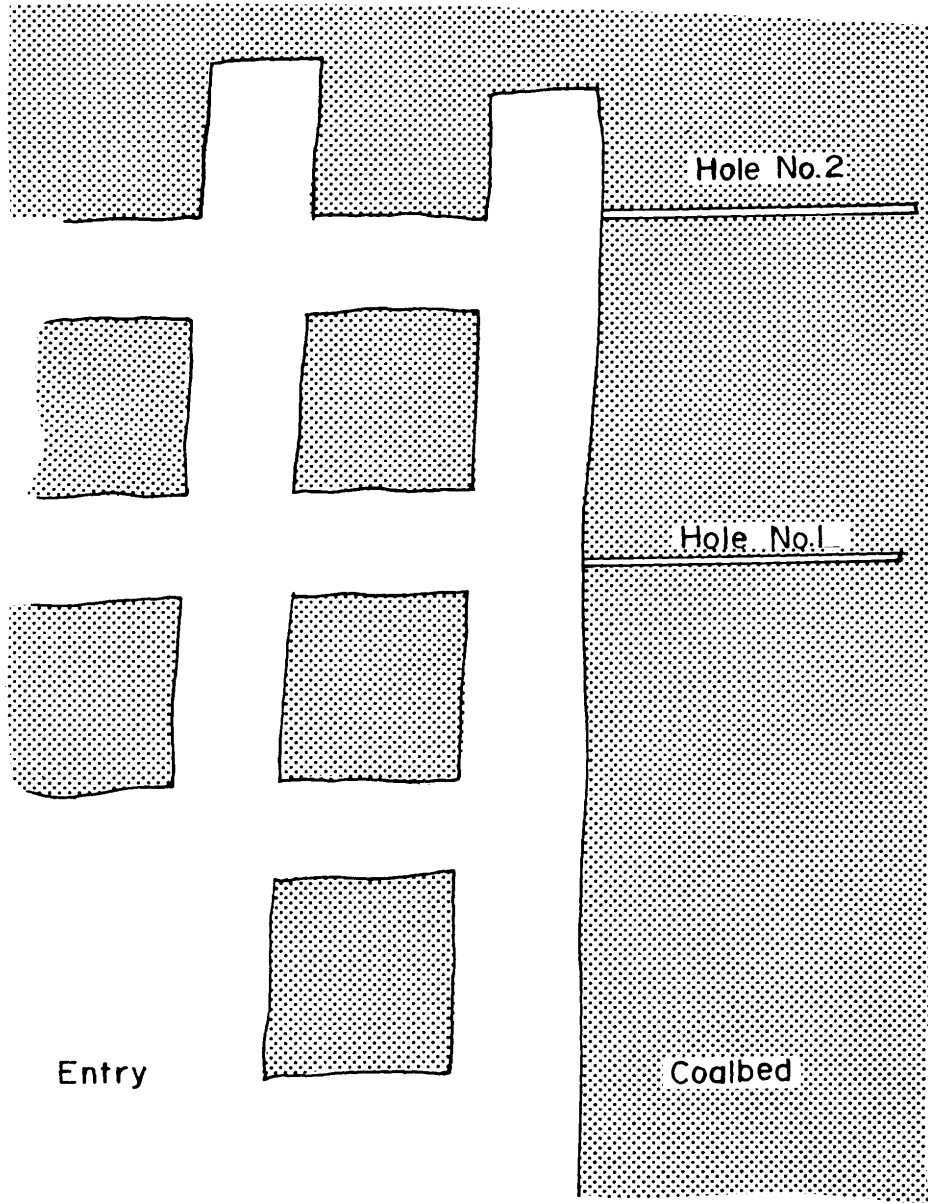

FIGURE 1. - Plan view—coal mine entry with two boreholes.

Some typical pressure curves for holes Nos. 1 and 2 are given in figure 2. Most of the pressure curves we have obtained are similar to these; that is, zero pressure is found at or near the face or rib, followed by a pressure that increases with depth and gradually levels off deep within the coal. In a gassy mine in the Pittsburgh coalbed the highest measured pressures can be several hundred pounds per square inch. The actual value depends on the overburden height, and in many instances we have measured gas pressures that were about the same as the hydrostatic head for that depth. Unfortunately, these curves do not represent the real situation very well. For instance, figure 2 shows zero pressure at the working face and therefore we might expect zero amount of gas in the coal here. Of course, this is not

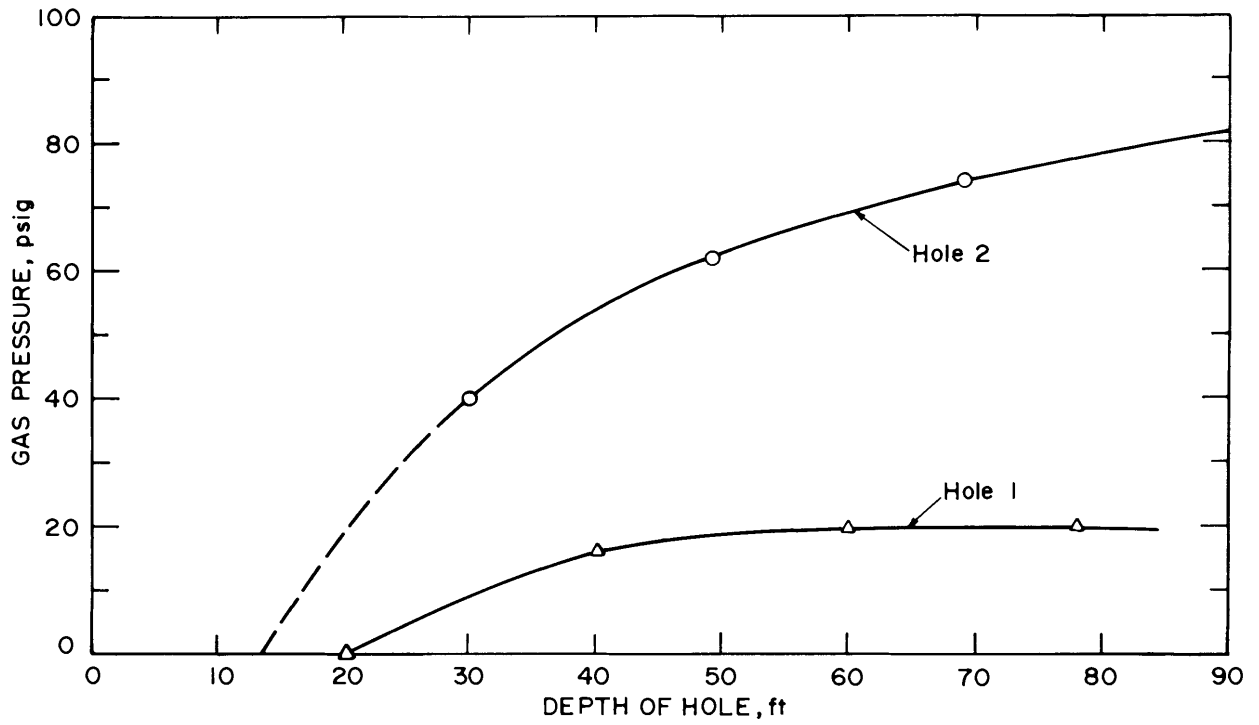

FIGURE 2. - Pressures measured within a coalbed.

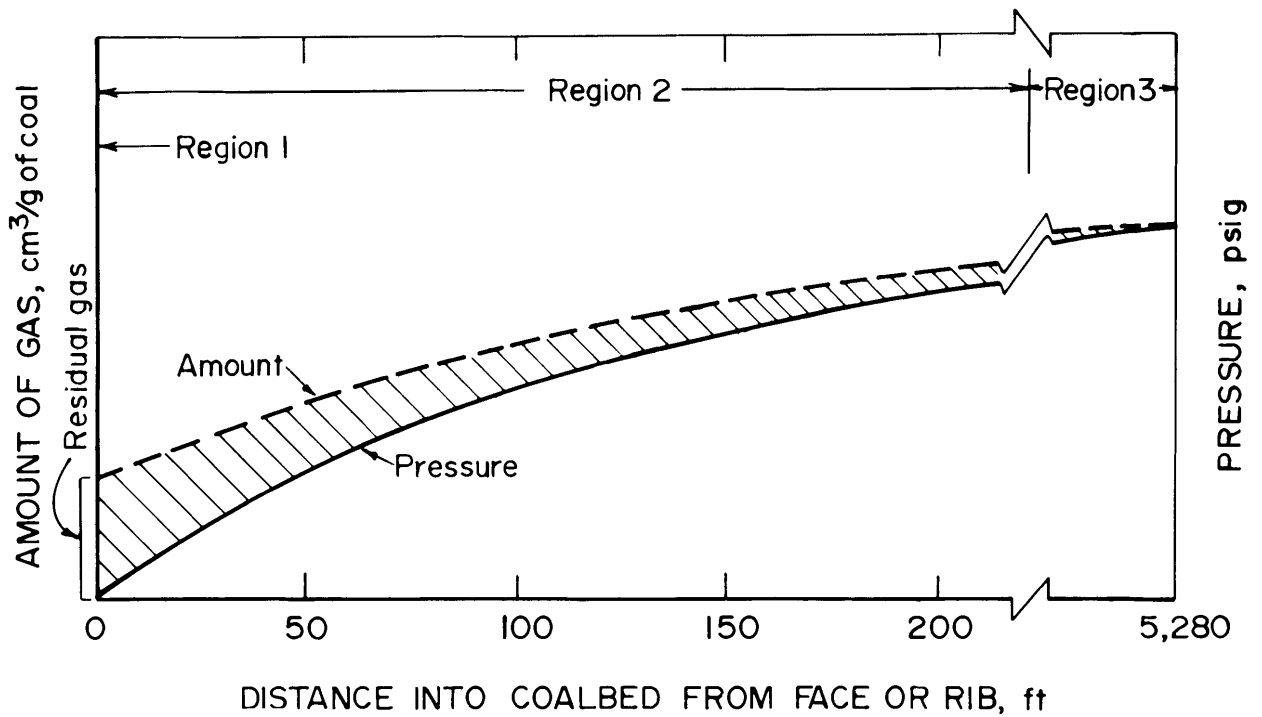

FIGURE 3. - Gas amount and pressure curves.

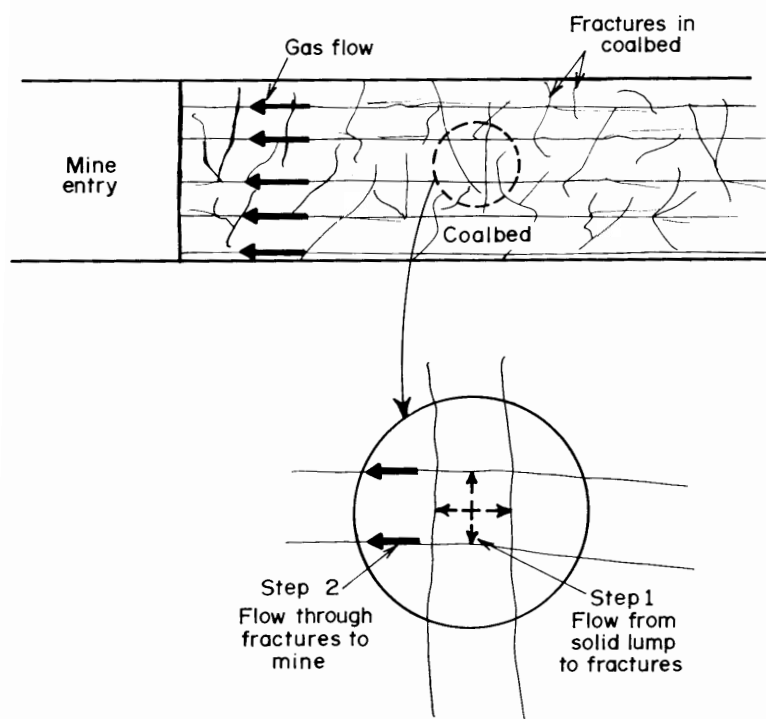

FIGURE 4. - Modes of gas flow through coal.

This is represented diagrammatically in figure 4 as a two-step process. Most of the gas in a typical working section emerges from these fractures, and it originates in that part of the coalbed where the pressure gradient is maximum. Obviously there will be exceptions, but this answers our first question about where most of the gas at the face comes from. In fact, it also answers the second question about gas in broken coal. Gas is retained in broken coal because coalbeds are solid lumps surrounded by fractures.

This division of the gas flow into two steps also accounts for a number of coalbed features that are not easily explained otherwise. Two very different types of coal will be considered--those from the Pittsburgh and Pocahontas No. 3 coalbeds.

<u>Coal</u>	<u>Nature</u>	<u>Flow from solid coal</u>	<u>Flow through fractures</u>
Pittsburgh.....	Hard, blocky well-defined fractures.	Slow.....	Fast.
Pocahontas No. 3.....	Soft, friable poorly defined fractures.	Fast.....	Slow.

Underground, the permeability of the coalbed is controlled by the fractures. This means that the Pittsburgh coalbed is much more permeable, and for a given gas pressure, this coal will release gas more quickly than coal in the

realistic. We know there is gas in the coal at the working face. It is the same gas that is emitted from the broken coal as it is mined and carried away. There is a technique to measure the volume directly, without depending on the pressure curve, and the actual volume or amount curve is added in figure 3. The amount curve shows there is gas in the coal at the working face. Here, it is called the residual gas.

Why the apparent discrepancy? It is because coalbeds are essentially solid lumps surrounded by fractures. Methane originates in the solid lump, but to get to the mine it first flows out of the solid, and then through the fractures.

Pocahontas No. 3 coalbed. However, if we consider an individual lump of solid coal--say a lump on the conveyor belt or one taken back to the laboratory--then the lump of Pocahontas No. 3 coal will give off gas more quickly, assuming that initial amounts are the same.

Theoretical calculations for these pressure curves show that the curve for hole No. 1 is lower than it ought to be (fig. 2). The only way we can account for this is to assume that the rate of the second flow step (flow through fractures) increases with time. Apparently this occurs because tiny amounts of water originally trapped in the coalbed fractures block gas flow. Following mining, this water slowly drains into the mine unblocking these fractures and increasing their permeability. We can represent approximately the time variation of permeability with this table:

<u>Pittsburgh coal</u>	<u>Approximate permeability (millidarcy)</u>	<u>How obtained</u>
Virgin coalbed.....	1	Vertical wells.
Coal adjacent to working face....	10	Horizontal holes.
Coal adjacent to old ribs.....	200	Do.

Much the same effect, but much less extreme, is observed in oil and gas wells. Figure 5 is a so-called relative permeability curve for coal. It

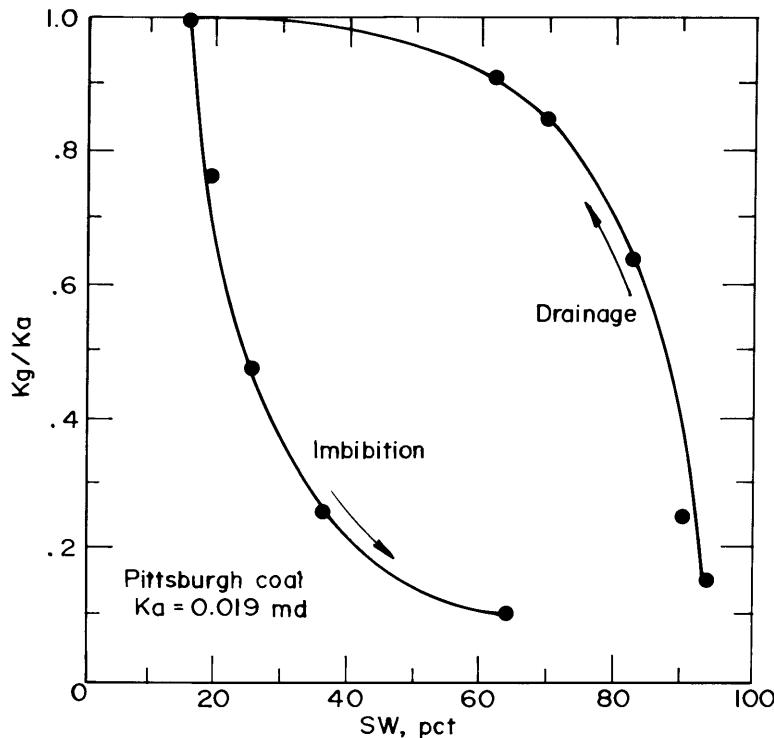

gives the permeability of a lump of fractured coal versus the water saturation in the fractures. Note how a very small change in water saturation can greatly affect the gas permeability.

What does this mean in practical terms? First of all, it shows why water infusion works. If draining water unblocks the fractures then infusing water (called imbibition) blocks them. Secondly, it explains why our vertical shaft degasification is working so well. The methane drainage rate has remained high even though the pressure has fallen off--the reason being an increase in permeability.

FIGURE 5. - Gas phase relative permeability of coal (Kg/Ka) versus water saturation, sw.

My own notion is that this relative permeability effect also explains in part why one section of a mine

may be gassier than another. If we keep in mind that:

$$\text{GAS FLOW} \propto \text{PRESSURE} \times \text{PERMEABILITY}$$

and if we recall that small changes in water saturation can produce large changes in permeability, then we can at least rationalize large changes in gas flow from section to section.

APPLICATIONS

Now that we have answered the original three questions and dealt with the fundamentals, we can turn to something new. The emphasis today is on practical and workable things a mine operator can use, and one of the things I have been working on is a method to forecast approximately the methane emission from a prospective mine by measuring the methane content of an exploration coal core. Those of you who have been at an exploration site when a wet coal core was brought to the surface, may have noticed methane bubbles on the surface of the core. If instead of watching the bubbles, we enclose the core in a sealed container, we can measure the amount of methane in the core. In figure 6, emission from the core is used to displace water in an inverted graduated cylinder. This is not quite enough, however, for a way is needed to account for the methane lost from the core as it was being brought out of the vertical borehole. There is a way to do this (fig. 7). If the emission rate into the inverted graduated cylinder is plotted versus the square root of time, a backwards extrapolation to zero time can yield a figure for this lost gas.

The next step is to correlate the gas in the core with the gas output of some existing mines. Figure 8 shows such a correlation for six mines. In

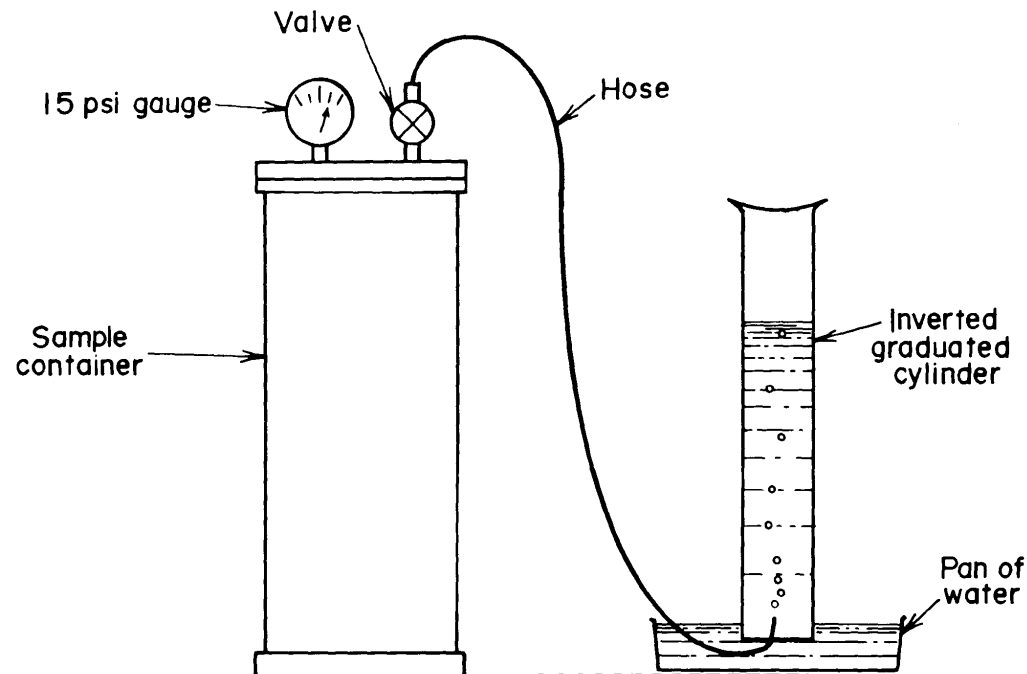

FIGURE 6. - Apparatus used to measure gas emission from a coal sample.

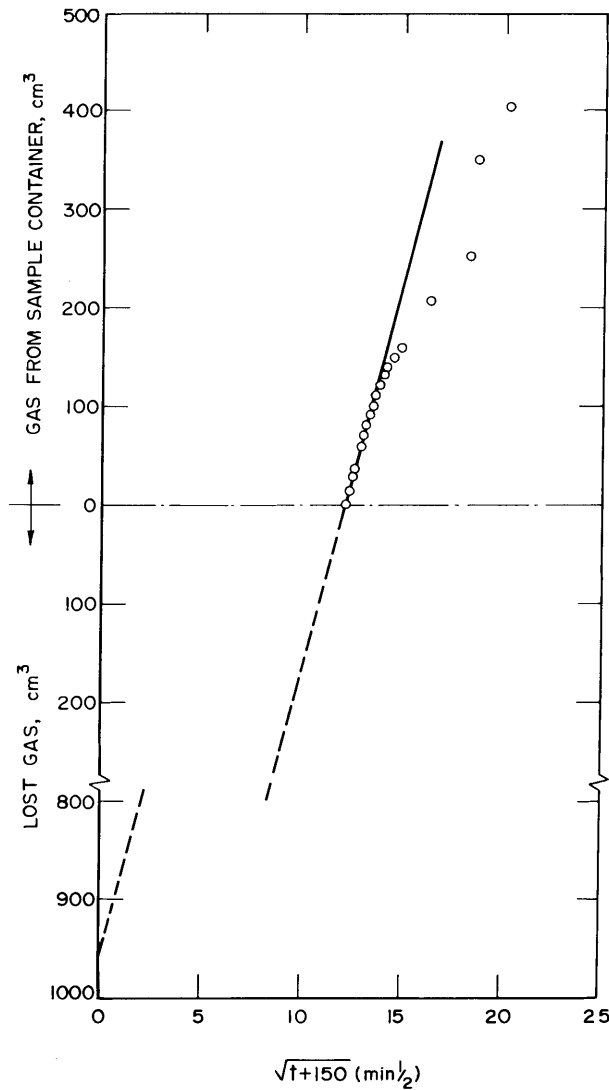

FIGURE 7. - Typical gas emission rate curve from a coal sample.

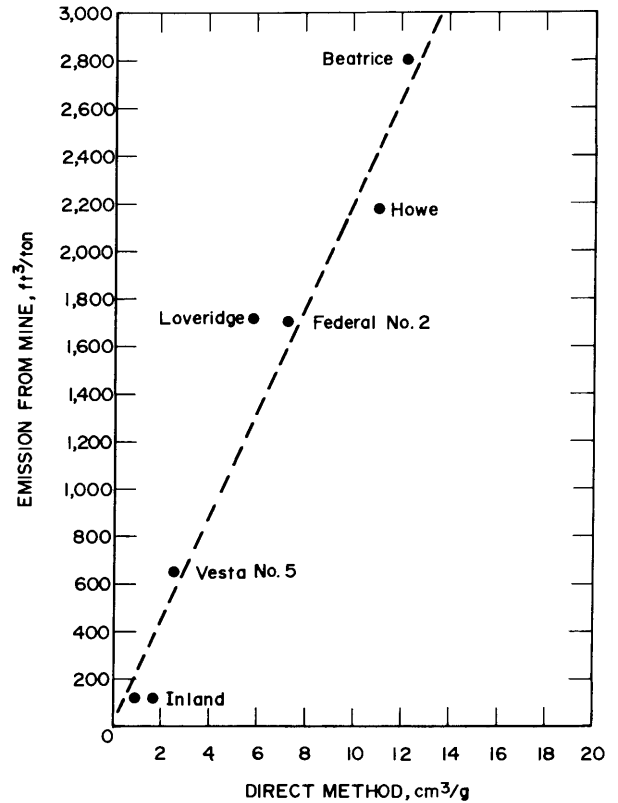

FIGURE 8. - Gas emission from coal samples and from nearby operating mines.

every case the vertical borehole from which the core was extracted was within a mile or so of the mine. Here, of course, the mines already existed, but there is no reason why this graph could not be used to predict the emission, at least approximately, for mines that have not yet been started. I have presented only the barest sketch of the method here. Additional details can be obtained from Bureau of Mines RI 7767.²

²Kissell, F. N., C. M. McCulloch, and C. H. Elder. The Direct Method of Determining Gas Content of Coalbeds for Ventilation Design. BuMines RI 7767, 1973, 17 pp.

DEGASIFICATION THROUGH VERTICAL SHAFTS

by

H. H. Fields¹

ABSTRACT

Initial gas flows from seven holes drilled (average depth 618 feet) from the enlarged bottom of an 839-foot-deep borehole were 79,000 to 257,000 cfd. The maximum in situ gas pressure measured from a point 190 feet in the coalbed was 203 psig, and initial water flow averaged 6.8 gpm/hole. After 190 days of degasification the gas flow is averaging 508,000 cfd from all holes and a total of 97,000,000 ft³ of methane has been liberated. This is 83 percent of the gas calculated to be in the affected area of coal. In situ pressure is holding at 12.7 psig, and water flow averages 0.34 gpm/hole.

INTRODUCTION AND STUDY AREA

The Bureau of Mines has been interested in mine safety for more than 60 years. In addition to other areas of safety, work is in progress in methane control, including removal of methane from virgin coalbeds and from actively pillared and old gob areas. The purpose of this study was to determine the effectiveness of long holes drilled into solid coal in very gassy virgin areas of the Pittsburgh coalbed. Methane exists under pressure in micropores, joints, and fractures of gassy coalbeds.² In many areas, it is also present in adjacent strata at various distances above and below the coalbed.

From the results obtained thus far, it is now evident that almost complete degasification can be effected over a significant area if accomplished ahead of mining. This study is concerned with the drilling of long holes in the coalbed from the bottom of an enlarged borehole. The study area (fig. 1) is located in the 3 South mains, in a barrier pillar of Eastern Associated Coal Corp.'s Federal No. 2 mine. After drilling the holes into the coalbed, the gas is then bled off through a piping system to the surface where the total flow and system pressure is measured and then vented to the atmosphere; it may later be utilized by a gas company having gas lines nearby. As far as

¹Mining engineer, Pittsburgh Mining and Safety Research Center, Bureau of Mines, U.S. Department of the Interior, Pittsburgh, Pa.

²Cervik, Joseph. An Investigation of the Behavior and Control of Methane Gas. Min. Cong. J., v. 53, No. 7, July 1967, pp. 52-57.

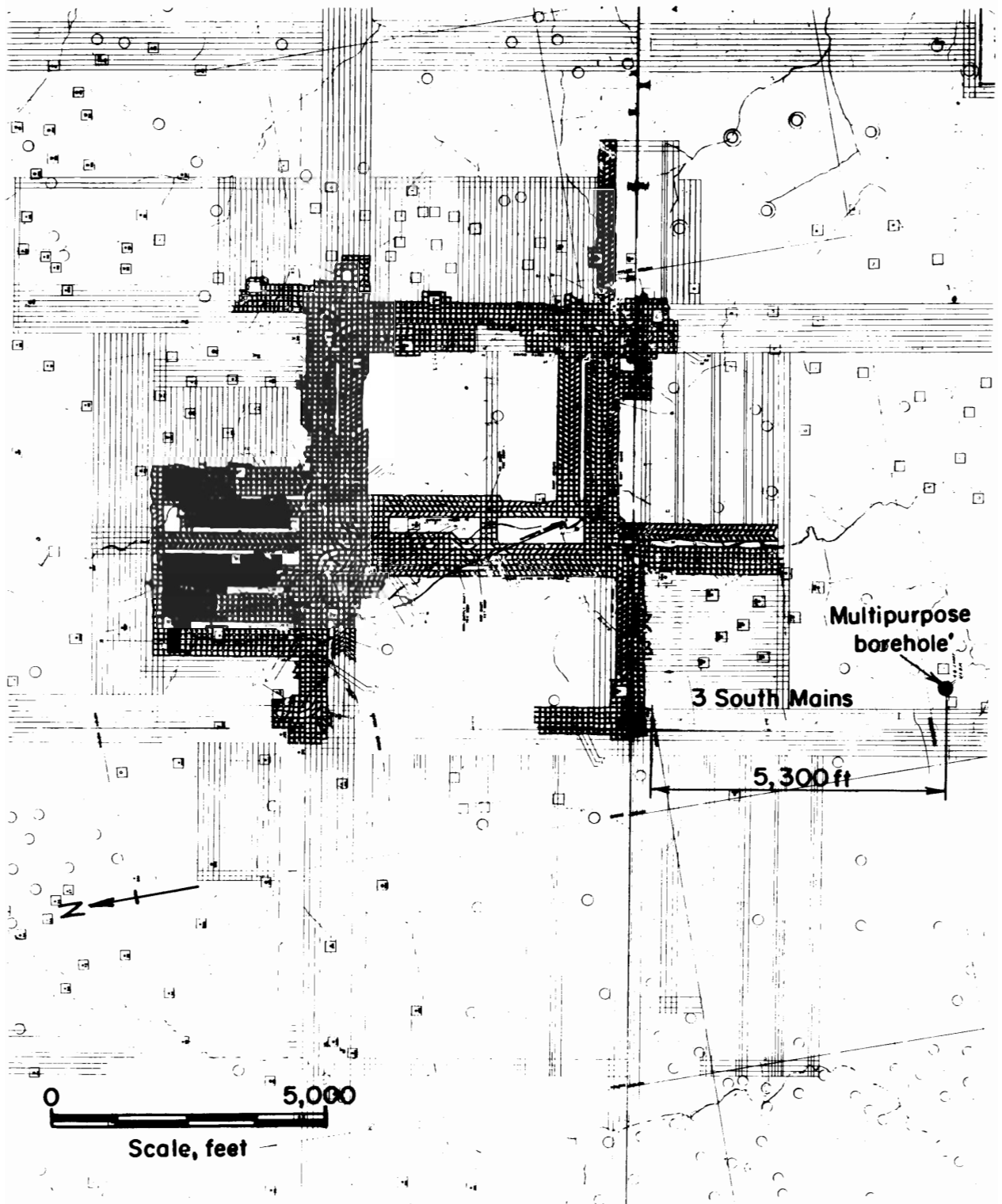

FIGURE 1. - Federal No. 2 mine location of multipurpose borehole.

we know, this exact technique has not been undertaken elsewhere in this country. Some of the values of this type of degasification ahead of mining are:

1. Reduce ignitions at the face, thus reduce the explosion hazards.
2. Reduce ventilation costs.
3. Increase coal production.
4. Conserve natural gas.

CONSTRUCTION OF THE MULTIPURPOSE BOREHOLE

A 3-in diameter exploratory hole was drilled first to provide the geological information for drilling the 74-in diameter borehole through the coalbed. A large rotary drill rig was erected on a 20- by 20- by 3-ft-thick concrete pad (fig. 2). The drill has a "dry weight" capacity of 600,000 lb and weighs approximately 1,000,000 lb fully assembled. An 84-in diameter hole was then drilled 50 ft to sound rock and lined with a 74-in diameter steel casing, and cemented in place to prevent inflow of surface water (fig. 3). Subsequently, a 72-in-diameter hole was drilled 839 feet to the bottom of the Pittsburgh coalbed. The hole was lined with a variable thickness, 24-in-diameter steel casing (1-in at the bottom and 1/2-in at the top) and designed to withstand full hydrostatic head. Two 3-in and two 4-in pipes were installed by tack welding to the outside of the 24-in casing for electrical, dewatering, and degasification service to the borehole bottom. The casing was then cemented to the surface in four stages.

SURFACE PLANT

After removing the drill rig, the surface plant was constructed at the site (fig. 4). A mine hoist having a total capacity of 8,000 lb was installed and a tripod type head frame was erected over the borehole. A variable speed ventilation fan rated at 9,000 cfm at 12-in water gage was located 100 ft upstream from the borehole. (Because of methane gas all electrical equipment was permissible by U.S. Bureau of Mines standards.)

A high-pressure degasification exhauster having a total capacity of 1,500 cfm at 4 in of mercury was installed 200 ft from the ventilation fan and 100 ft from the borehole. Total gas flow from the seven horizontal holes was measured by an 8-in turboflowmeter located at the surface. To keep the borehole dewatered during construction, a 50-gpm air-driven displacement type pump and a 50-gpm submersible pump were used.

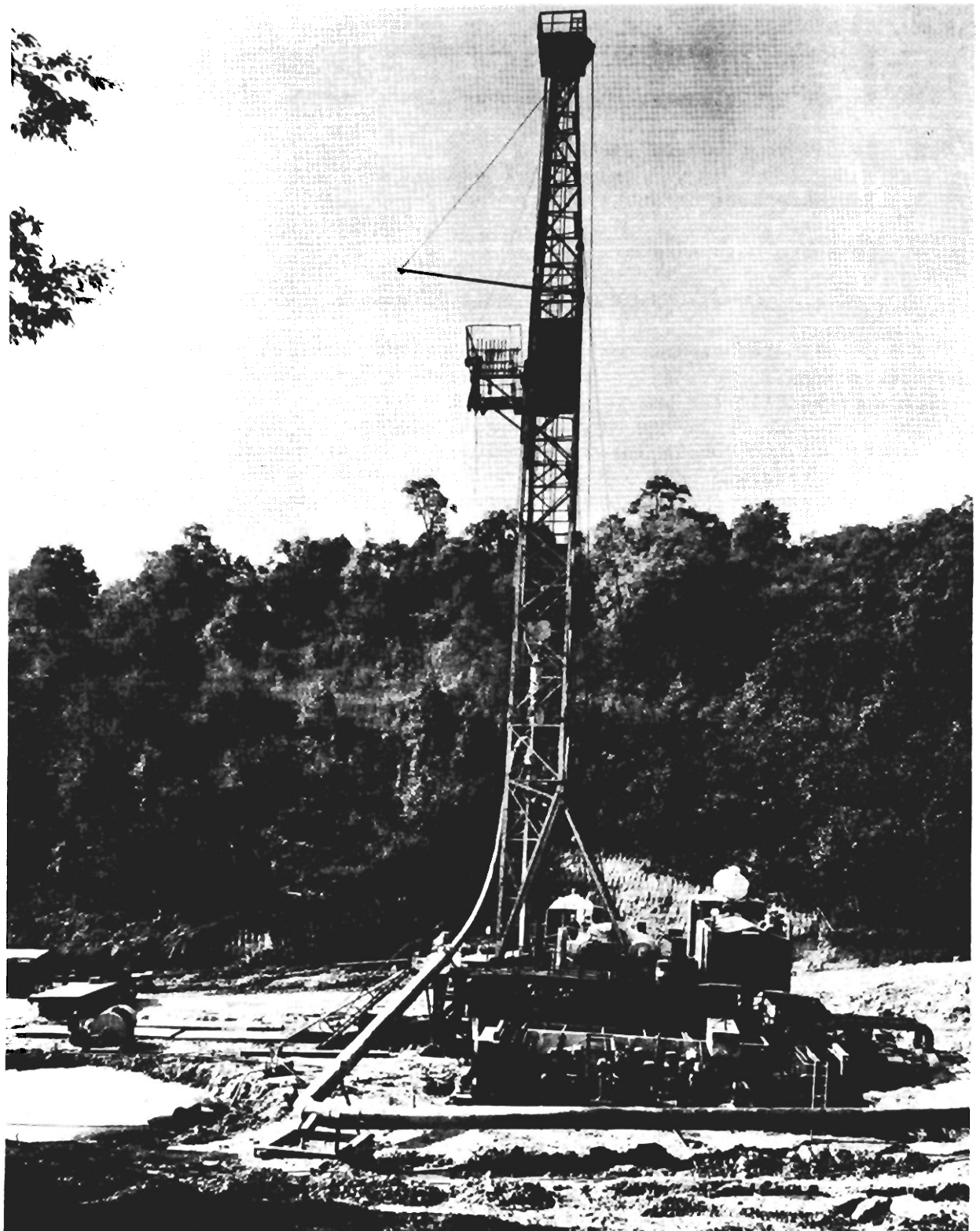

FIGURE 2. - Rotary drill rig.

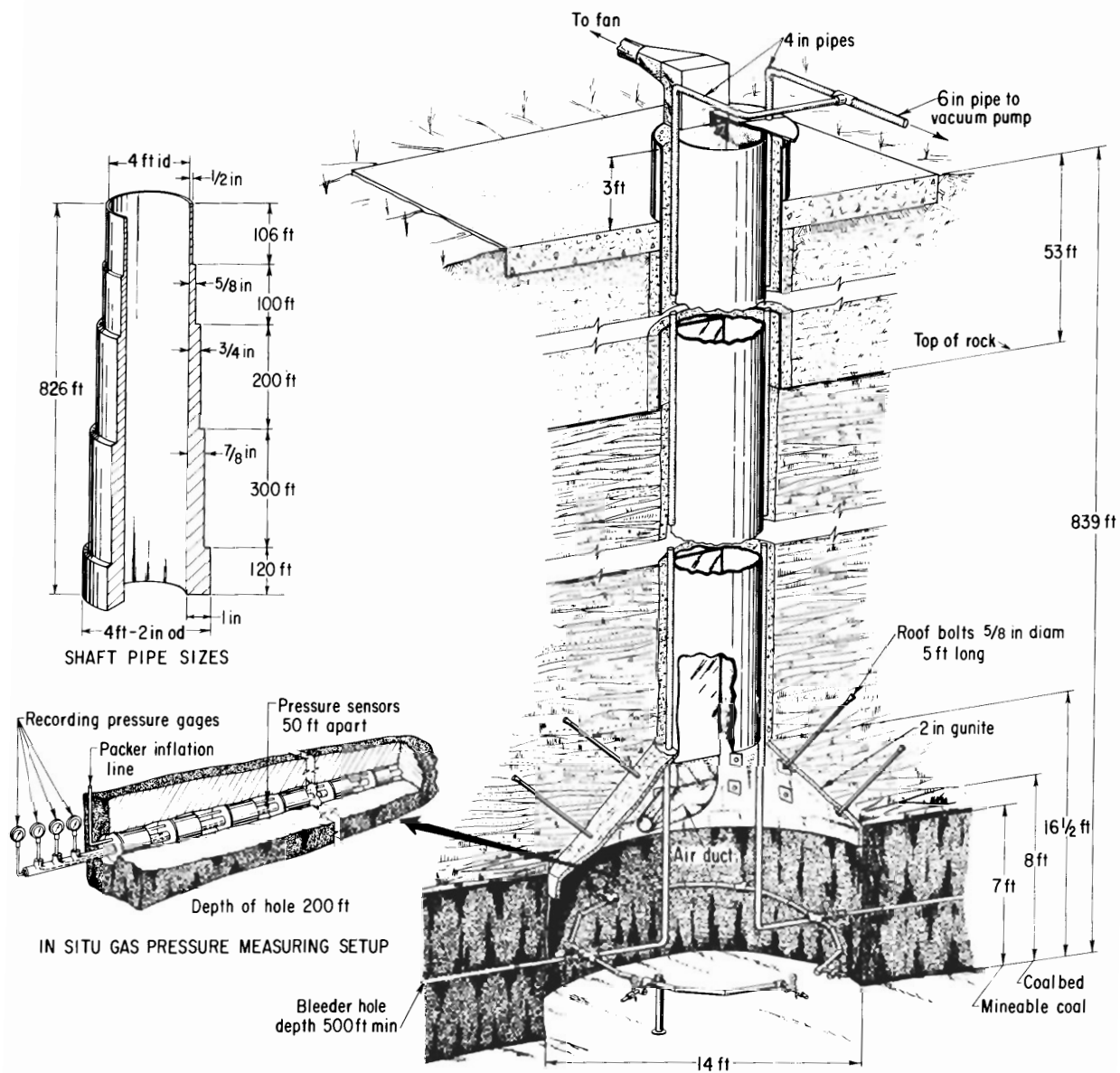

FIGURE 3. - Multipurpose borehole for degasification of virgin coal.

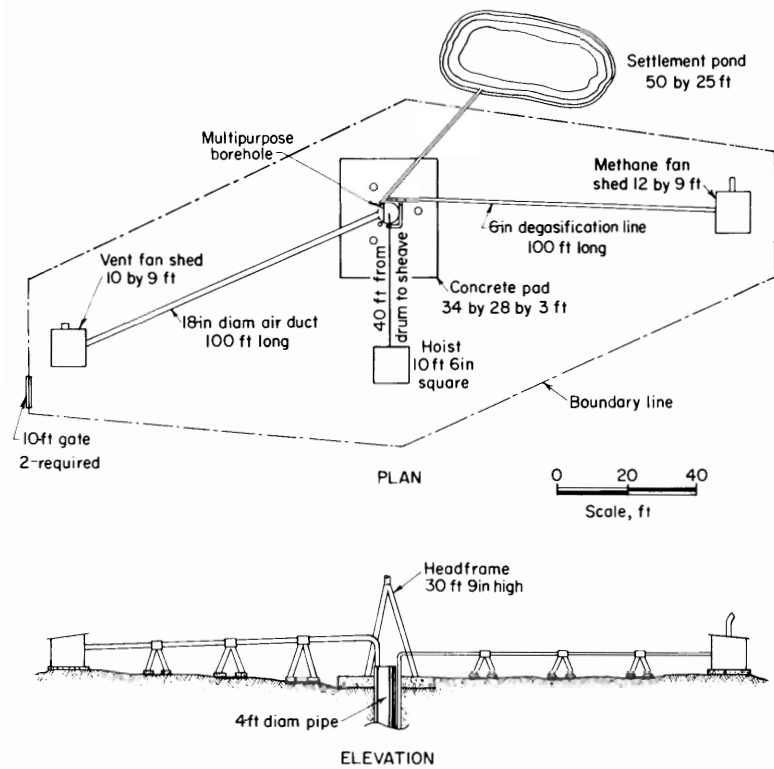

FIGURE 4. - Plan elevation—surface plant layout at multipurpose borehole.

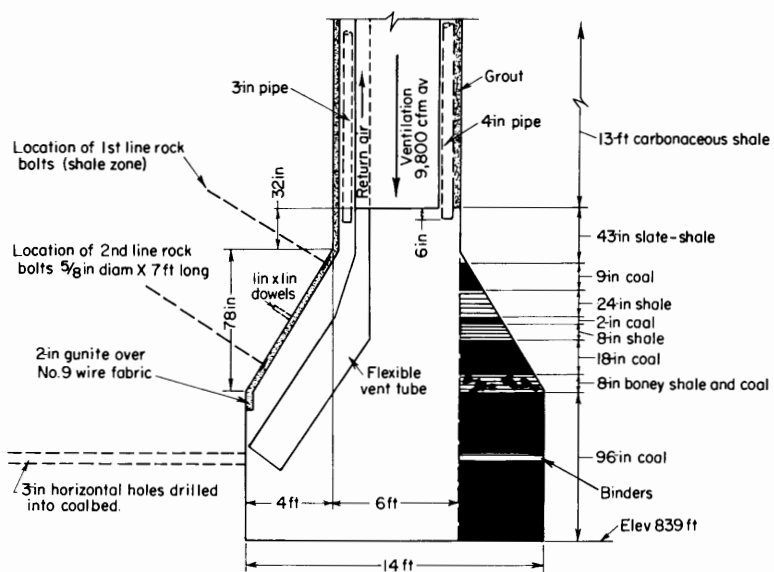

FIGURE 5. - Lithology of borehole bottom.

ft, with surveys being made generally at 150, 300, and 400 ft. At a depth of approximately 400 ft, the 5-ft stabilizer was followed by a weighted 2-1/2-in, 5-ft drill rod, and the hole advanced to a depth of 500 ft. All holes, except one, were

ENLARGEMENT OF THE BOREHOLE BOTTOM

After removing the drilling fluid, the sand bags, and gravel, the borehole was progressively enlarged on a 34-degree angle to a 14-ft diameter chamber within the coalbed. The sloping rock section was rock bolted on two circumferential lines and coated with a 2-in thick layer of reinforced gunite (fig. 5).

DRILLING HORIZONTAL HOLES

The degasification holes (fig. 6) were drilled in the coal with a Sprague and Henwood Model 40CL standard core drill. Measured control of torque, drilling speed, and thrust was not possible with this unit. For the most part, the holes were inclined upward 1/4 degree starting at a point approximately 34 in below the top of the coalbed and were drilled to a depth of 55 ft. An NX drag bit fitted to a 10-ft packed hole stabilizer, 2-29/32 in. in diameter, followed by a 10-ft drill rod and a 5-ft packed hole stabilizer was used from 55 to 100 ft in depth.

The stabilizer assembly (fig. 7) then was changed to a single packed hole stabilizer, 5 ft in length, immediately behind the same drag bit. The holes were advanced with this assembly to about 390

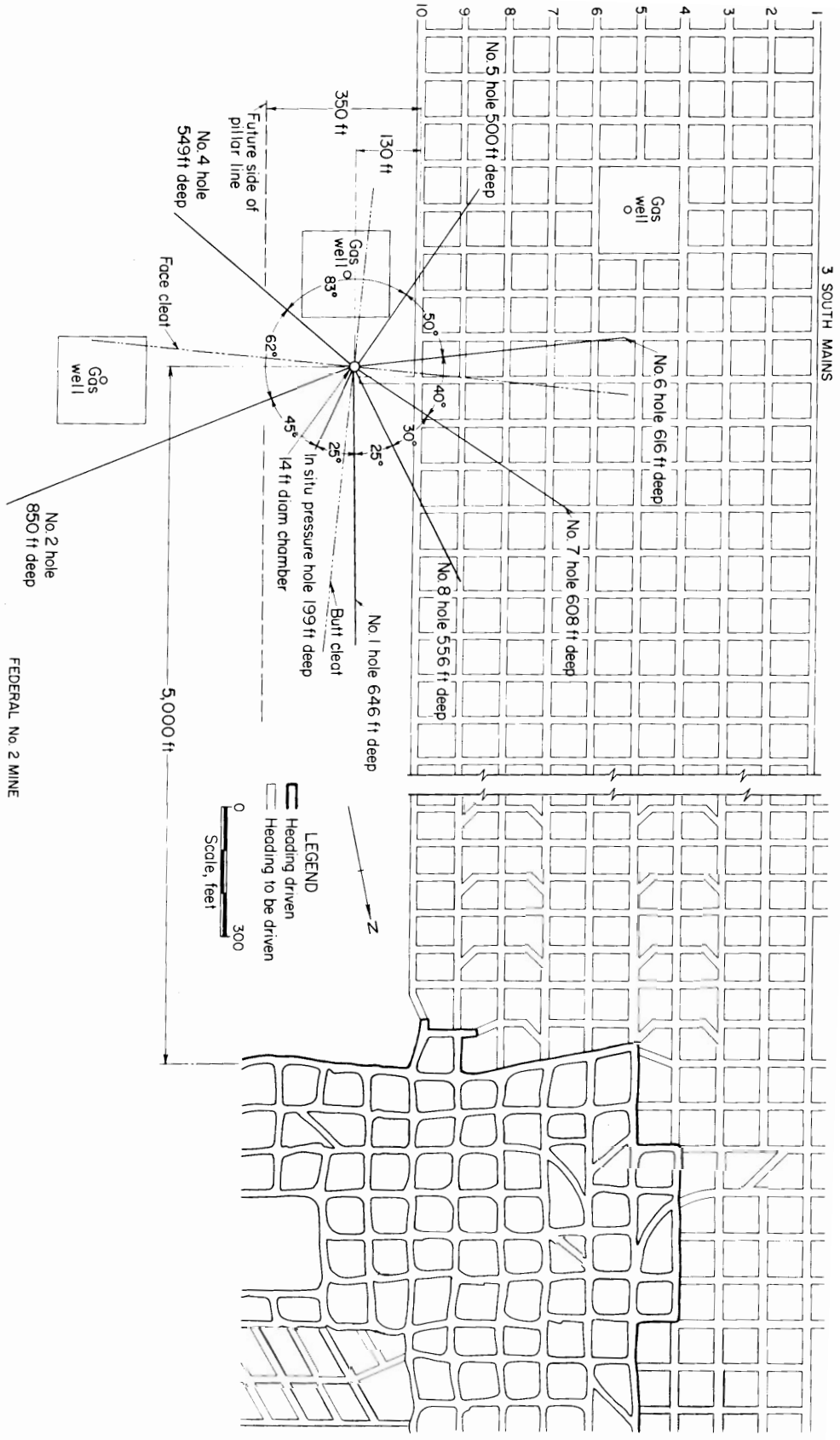

FIGURE 6. - Location of multipurpose borehole with horizontal holes in coalbed.

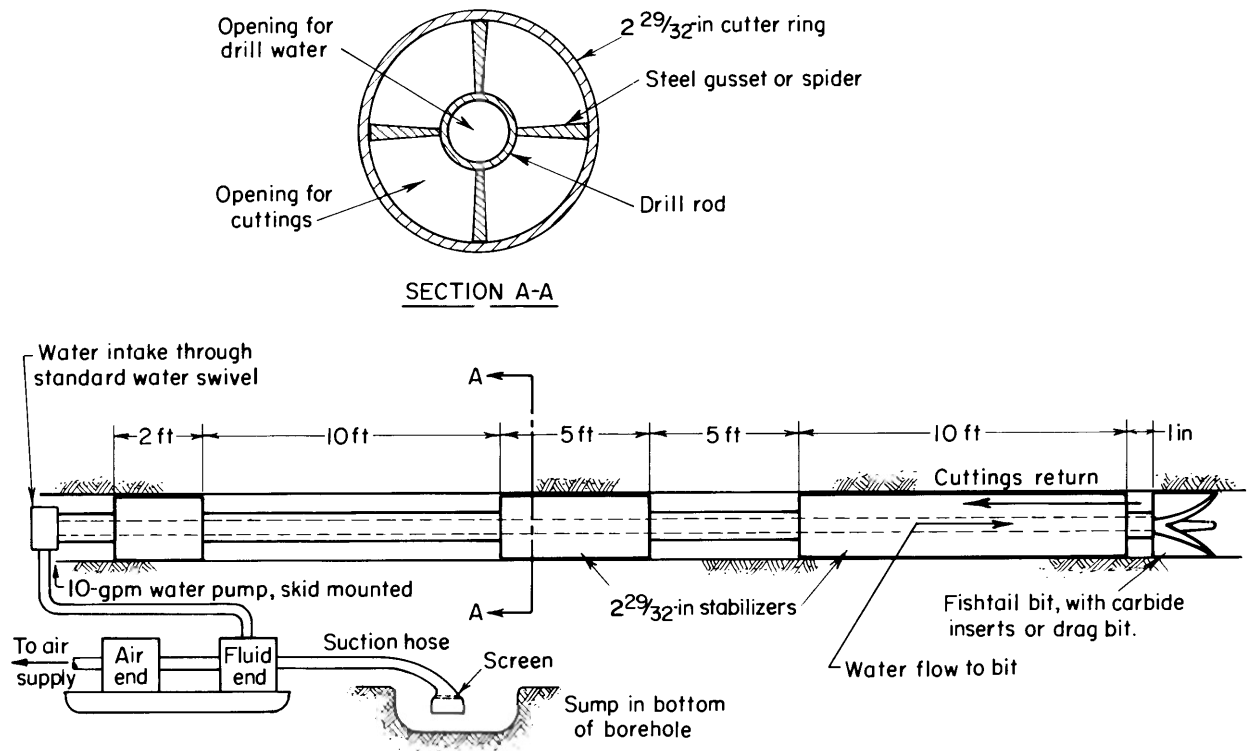

FIGURE 7. - Stabilizer assembly.

advanced beyond 500 ft, assuming only minor characteristic deviations would be realized by using the two basic stabilizer assemblies described above. The holes were advanced in excess of 600 ft using the two-unit stabilizer assembly, then changed to the single stabilizer assembly; one hole was drilled to a maximum of 850 ft.

A mechanical packer was inserted in the hole and the hole was shut in to prevent outflow of gas until all degasification holes were completed. The in situ pressure hole was "packed" with provision for measuring the gas pressure at four equally spaced locations. These later were replaced with one pressure point located 190 ft into the coalbed.

Each hole was connected from the mechanical packer to a Bureau-designed water trap, orifice plate for measuring pressure in and flow from each hole and to a 24-in-diameter by 72-in-high receiver tank. The two 4-in steel pipes grouted behind the 48-in casing were connected to the tank 160 degrees apart (fig. 8).

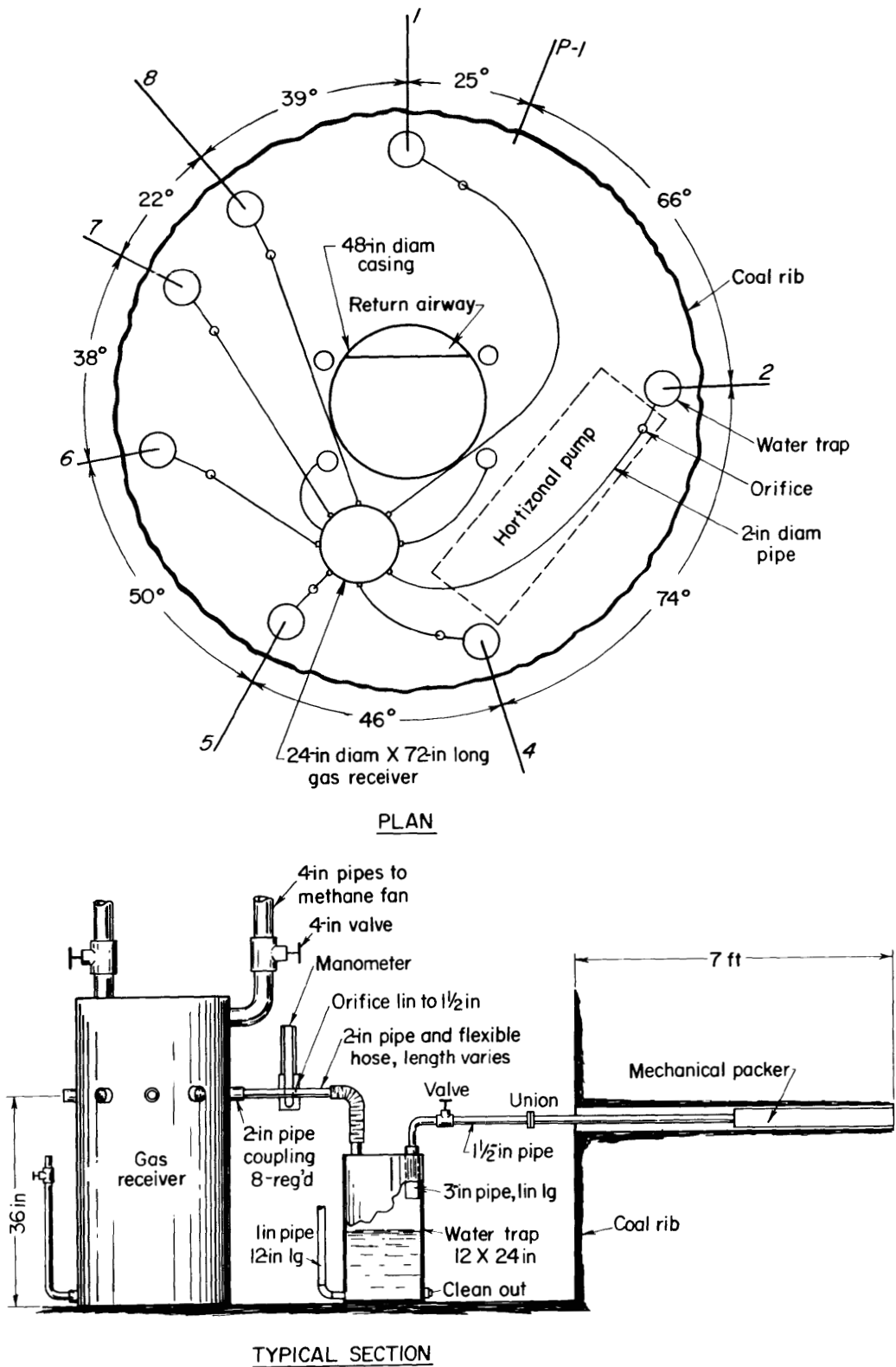

FIGURE 8. - Plan-typical section of collector system.

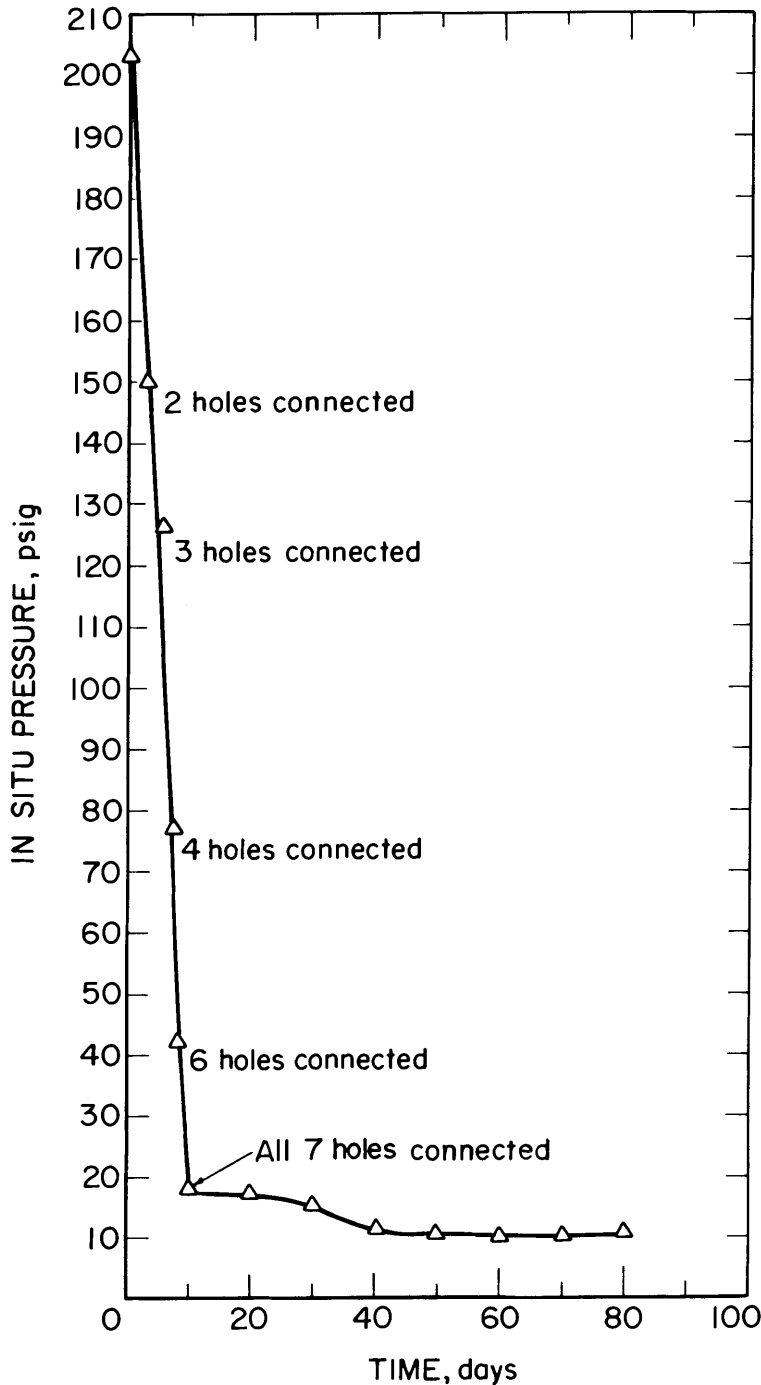

FIGURE 9. - In situ gas pressure.

In situ gas pressure (fig. 9) and volume measurements are made periodically (7 to 10 days) at the bottom of the borehole. In addition, total gas flow, pressure, and time also are read with the turbowflowmeter located on the surface.

RESULTS AND DISCUSSIONS

The initial gas flow rates are given in table 1. It is assumed that holes 7, 8, and 1 are shielded from the wells by the other holes (particularly 2 and 6), then the initial gas flow rate (GFR) in the absence of the wells would be given by the equation:

$$\text{GFR} = (0.18 - 0.1 \cos 2\theta) \text{ cfm/ft}^2 \quad (1)$$

where θ is the angle (displacement) measured clockwise from the face cleat located between holes 2 and 4. Note in particular the effects of the directional permeability on the flow (fig. 10); in the absence of wells, the maximum flow is from holes drilled along the butt cleats (B) and nearly perpendicular to the face cleats (F). However, as boreholes that pass near wells may have flow rates above the predicted values, it is not surprising to find that the initial flow rates from holes 2 and 4 were approximately twice as high

as those to be expected from equation 1. Further, comparing the flows from holes 4 and 7 (two diametrically opposed holes), we see that the flow from hole 4, which passes near a gas well, was about 2.5 times higher than that from hole 7, which does not pass near a well. This is in line with earlier

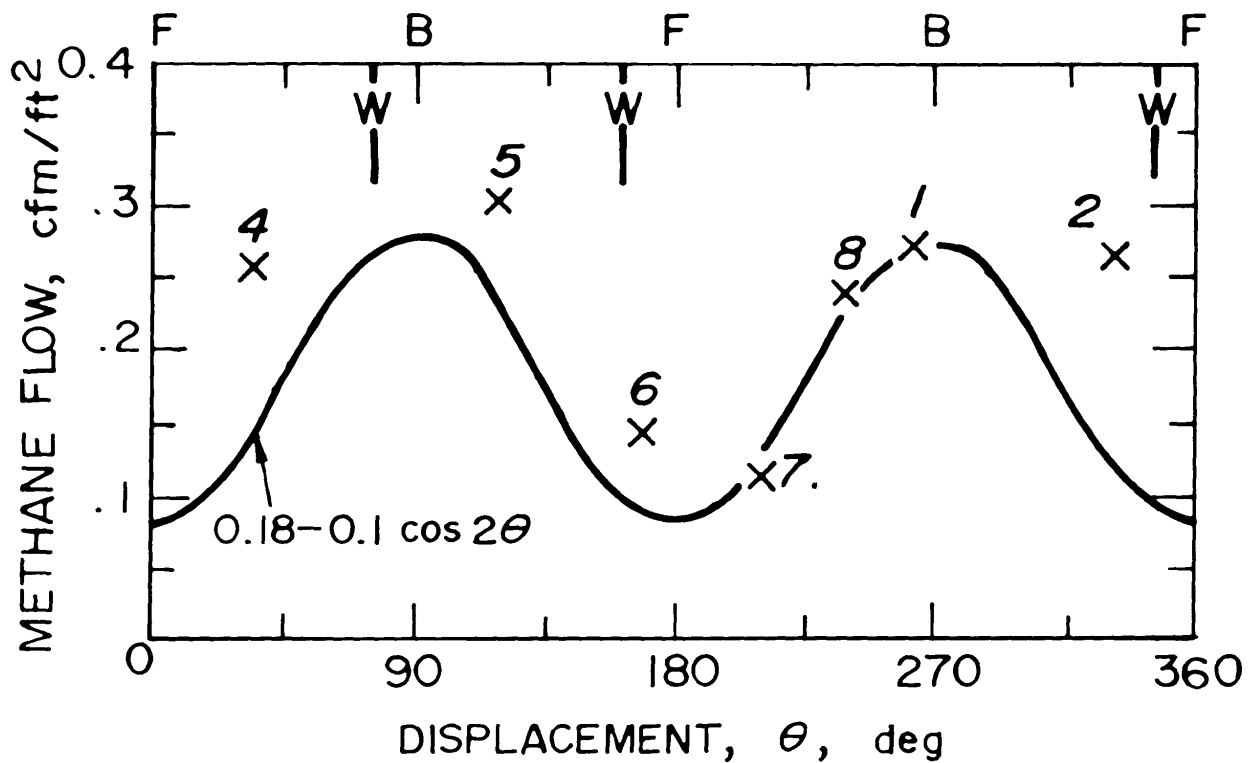

FIGURE 10. - Methane flow and displacement (fig. 6).

findings by Zabetakis³ on the effects of oil and gas wells on emission of methane in coal mines.

TABLE 1. - Initial data on the seven degasification holes

No. of hole (fig. 1).....	1	2	4	5	6	7	8	Total
Length.....ft..	646	850	549	500	616	608	556	4,325
Gas emission per 1,000 cfd.....	201	257	159	171	104	79	150	1,121
Gas flow per sq ft of coal surface in holes.....cfd..	396	385	369	435	215	166	344	2,310
Angle of hole with respect to face cleat ¹deg..	83.5	28	35	61	12	28.5	59	-
Distance from gas well.....ft..	0	180	160-400	130-370	300	0	0	-
Average water discharge.....gpm..	6.5	6.8	5.6	8.0	5.0	5.0	6.2	43.1
In situ gas pressure at 199-ft depth.....psi..	-	-	-	-	-	-	-	203

¹Face cleat is appreciably more permeable than the much shorter butt cleat.

³Zabetakis, M. G., T. D. Moore, Jr., A. E. Nagel, and J. E. Carpetta. Methane Emission in Coal Mines--Effects of Oil and Gas Wells. BuMines RI 7658, 1972, 9 pp.

After the initial flow rates were measured, the seven bleeder holes were connected to a common collector. The total methane emission from these holes fell for approximately 50 days and then began to increase (table 2). Interestingly, the emission rate fell by a factor of 2 (fig. 11), and the gas pressure in the coalbed fell by a factor 20 (fig. 9). However, during this period, a fair amount of water was removed from the coal (the average initial water flow rate was 6.2 gpm per hole); in 50 days this figure fell to 0.5 gpm per hole and the gas permeability of the coal increased. As a first approximation, the initial methane emission rates (MER) are proportional to the increase of the square root of the elapsed time, t :

$$\text{MER} = \frac{970}{\sqrt{1 + t/10}}; 0 \leq t \leq 40 \text{ days} \quad (2)$$

This simple equation yields values within about 5 percent of the smoothed (curve) data given in figure 11.

TABLE 2. - Total gas and water flows and in situ gas pressures
24 hours after all holes connected to collector

	Gas emission, 1,000 cfd	Average water discharge per hole, gpm	In situ gas pressure, psi
Initial.....	1,121	6.2	203
Twenty-four hours after all holes connected to collector.....	971	1.3	190
Days after above 24 hours:			
10.....	720	1.2	18
20.....	511	1.2	18
30.....	464	.8	17
40.....	444	9.5	11
50.....	460	.5	10
60.....	490	.5	10
70.....	438	.5	13
80.....	529	.5	13
90.....	500	.5	13
100.....	543	.5	13
110.....	480	.5	12.7
120.....	498	.45	12.7
130.....	516	.45	12.7
140.....	495	.45	12.7
150.....	519	.45	12.7
160.....	509	.45	12.7
170.....	528	.34	12.7
180.....	538	.34	12.7
190.....	522	.35	12.7
200.....	495	.35	12.7

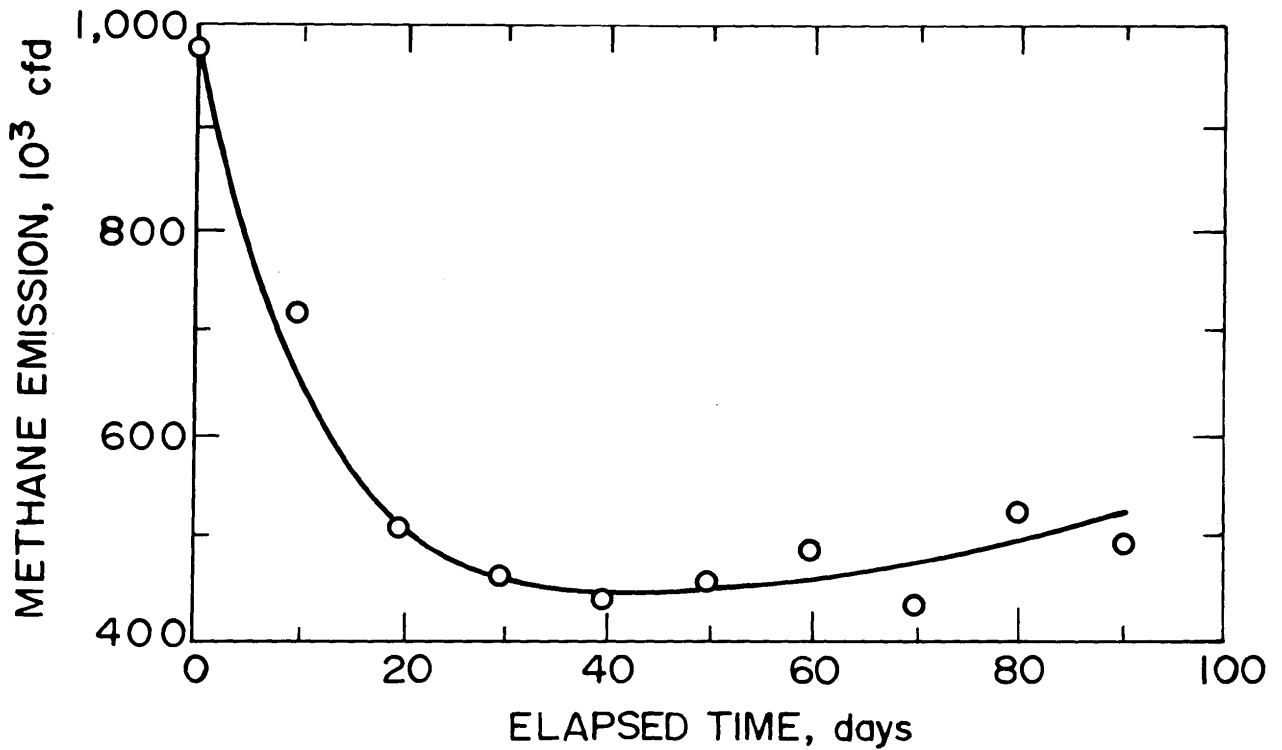

FIGURE 11. - Methane emissions.

A total of 102,000,000 ft³ of gas has been removed in 200 days from the virgin area involved. This is equivalent to 87 percent of the calculated gas in the area of coal involved. While the in situ gas pressure has dropped to 12.7 psig and water flow to 0.35 gpm/hole, the gas flow has averaged 509,000 cfd.

TABLE 3. - Analyses of two samples from total gas emission

	Sample 1	Sample 2
Ethane (C ₂ H ₆).....ppm..	300	321
Carbon dioxide (CO ₂).....pct..	9.5	9.0
Oxygen (O ₂).....pct..	0.6	1.2
Nitrogen (N ₂).....pct..	2.0	2.4
Methane (CH ₄).....pct..	87.9	87.4

Regarding the cost-effectiveness, it should be recognized that the expense of this study is very high (\$848,000). A much more practical approach is for coal companies operating in very gassy coalbeds to consider planning more air shafts with smaller cross-sectional areas than is the increasing practice today. It would be adequate to sink the shafts 3 years ahead of need and degasify the virgin coal by long holes as accomplished in conjunction with the multipurpose borehole.

CONCLUSIONS

Based on the degasification results obtained in 200 days, it can be concluded that the multipurpose borehole is a useful technique. It is concluded that final degasification will exceed appreciably the estimated volume of gas calculated to be in the area involved. However, the cost of using the multipurpose borehole technique is quite expensive; therefore, it appears advisable to consider using the technique of drilling degasification holes in the coalbed from the bottom of planned air shafts (sunk by conventional mechanized methods) in virgin coal areas approximately 3 years ahead of closest mine workings.

THE USE OF ISOLATED COAL PANELS IN THE PITTSBURGH COALBED

by

C. Findlay,¹ S. Krickovic,² and J. E. Carpetta³

ABSTRACT

The Bureau of Mines conducted methane emission rate studies during development of 1,800 ft of a set of three headings within a major coal panel (2,700 by 3,500 ft) which had been completely isolated by sets of headings for 12 months in a Pittsburgh coalbed mine in northern West Virginia. Minimum, maximum, and average emission rates were 2.1, 14.0, and 9.1 ft³ per ton of coal mined in the order named; and the maximum and minimum average production rates were 3.7 and 3.0 tpm, respectively, with continuous penetration rates being judged to be in excess of 5 tpm. No methane problems were encountered, and the methane emission rate of the panel was estimated to be in excess of 70 percent lower than the rates measured in development within two virgin coal areas in the same mine.

INTRODUCTION

Methane exists under pressure in the micropores, joints, and fractures of gassy coalbeds. In many mines it is also present in adjacent strata at various distances above and below the coalbed. An in situ gas pressure of 275 psi has been measured in the Pittsburgh coalbed, and permeability of the bed has been found to be high compared with that of other coalbeds.⁴ Because of this high pressure and permeability it is very advantageous safety-wise and production-wise to degasify the coalbed to the fullest extent practicable before mining. One procedure for draining methane from virgin coalbeds is to isolate major coal panels by developing sets of headings around them and to allow bleed-off for at least 1 year prior to mining within the panels.

Some coal companies have achieved partial and almost complete isolation without actually planning it. Ventilation problems, difficult mining

¹Mining engineer.

²Supervisory mining engineer.

³Mining engineering technician.

All authors are with the Pittsburgh Mining and Safety Research Center, Bureau of Mines, U.S. Department of the Interior, Pittsburgh, Pa.

⁴Cervik, Joseph. An Investigation of the Behavior and Control of Methane Gas. Min. Cong. J., v. 53, July 1967, pp. 52-57.

conditions and the need for greater production are the usual reasons for the development in adjacent areas that resulted in the isolated conditions. Other companies, mining in very gassy coalbeds, develop butt headings for longwall panels ahead of need and degasify the isolated panels by drilling holes in the coalbed on approximately 100-ft centers and approximately 200 ft deep from both sides of the panels. In relatively few cases, where total isolation of a major coal panel is planned, mining within the panel is started promptly upon completion of the isolation. Although such a procedure improves safety and productivity to some degree, some time usually is needed to bleed off the methane for significantly greater advantage.

LOCATION AND DESCRIPTION OF STUDY AREAS

Figure 1 shows the locations of eight study areas in Federal No. 2 mine operated in northern West Virginia by Eastern Associated Coal Corp.

Area 1 was located in the development of four headings of 2 South mains to complete the set of 10 headings of the major panel that had been isolated 12 months before this mining was undertaken. Areas 3 through 6 and 8 were located in a set of three headings that were being developed in the isolated block (2,700 by 3,500 ft) to improve ventilation. The headings were developed 1,800 ft at the end of studies.

Area 2 was located in six of the 10 projected 2 North mains headings in virgin coal, and area 7 in seven of the 10 projected 2 South mains headings also in virgin coal.

MINING METHOD AND EQUIPMENT

The centers of headings and breakthroughs and widths of both in the isolated panel were 100, 80, and 13 ft, respectively. They were 90, 80, and 13 ft in 2 North mains and 100, 90, and 14 ft in 2 South mains.

Thickness of the coalbed was 9 ft, of which 7 ft were mined under 735- to 845-ft-thick overburden. Mining was done with boring-type continuous miners in all study areas except No. 7, where a fullface ripper-type unit was used. Coal was discharged to the floor where conventional loaders transferred it to 10-ton-capacity shuttle cars for transportation and unloading into the belt feeders for rapid handling and uniform discharge onto tail ends of belt conveyors in all study areas. Each miner was generally served with two shuttle cars.

VENTILATION AND MONITORING

All study areas within the isolated coal panel were ventilated with one split of air, except area No. 1; the outside left and right headings were intake and return airways, respectively, and the middle (belt conveyor) heading a regulated intake (about 2,000 to 3,000 cfm) to prevent excessive velocity while maintaining the methane concentration below 1 percent. Areas 1, 2, and 7 were ventilated with two air splits, with a single return airway for

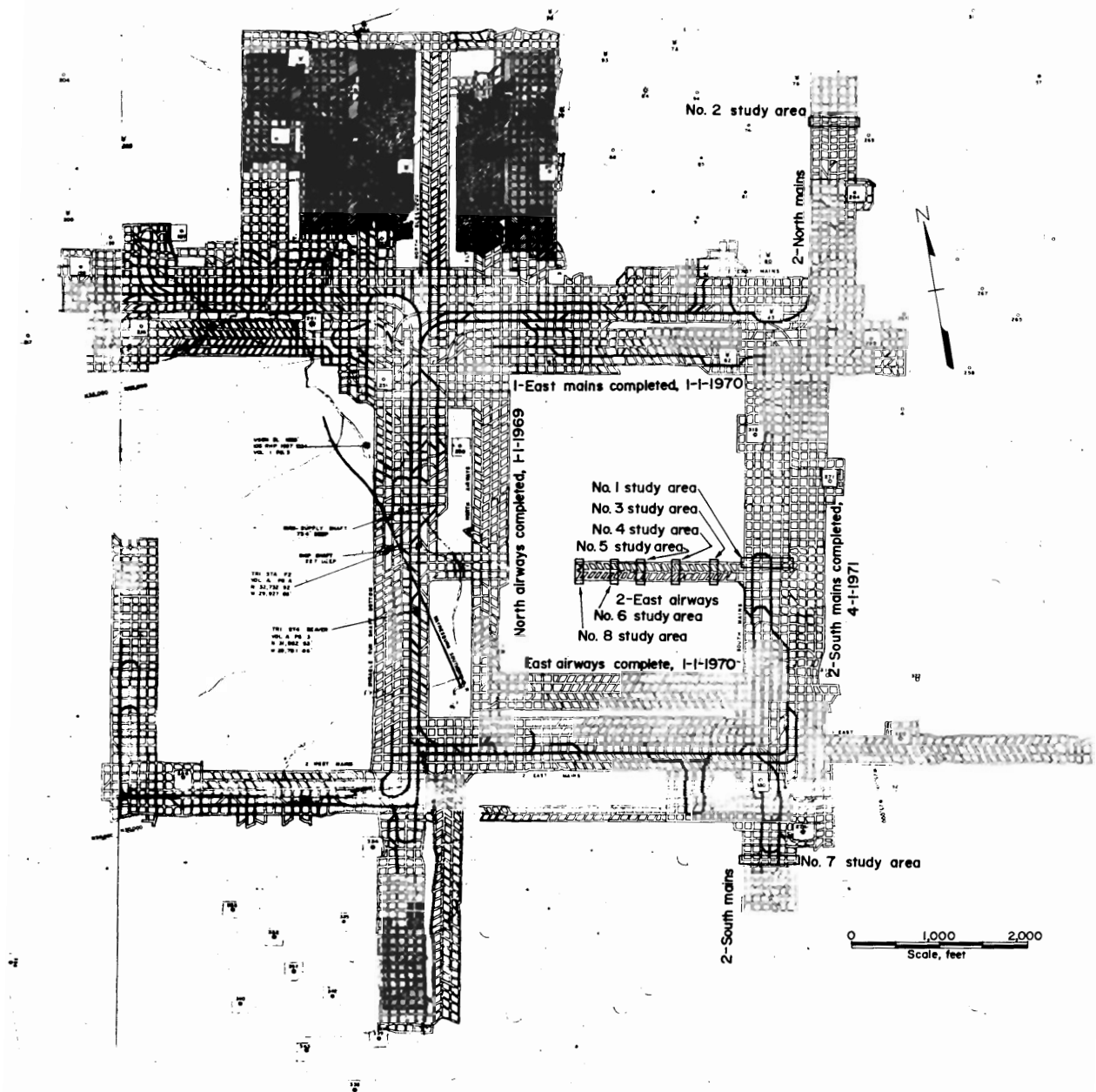

FIGURE 1. - Location of study areas.

each split, except area 7, which had two returns for one split and one for the other. The belt conveyor heading in each area was a regulated intake.

All air velocities and methane concentrations were measured with hand-held instruments. Airflow measurements were obtained by traversing at uniform speed with an anemometer across accurately measured cross-sectional areas every hour; methane concentrations were obtained at the average velocity points just in by the last masonry stoppings at 5- to 10-min intervals. When the miners were not operating and the belt conveyors were empty, intake

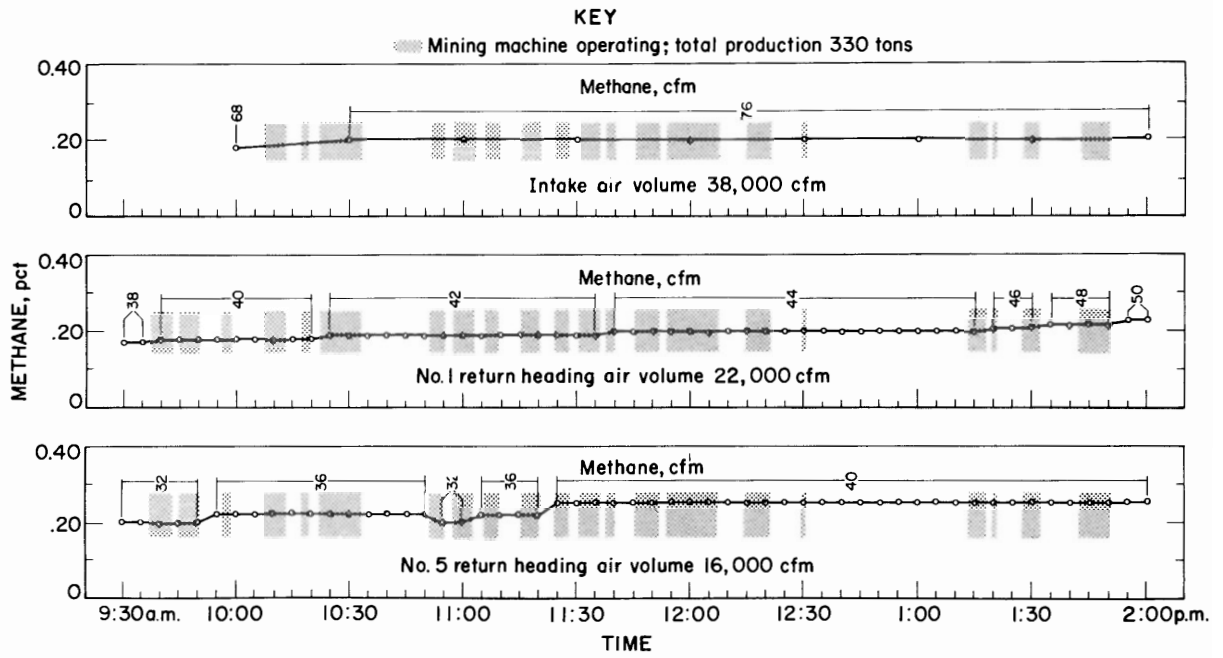

FIGURE 2. - Data from study area 1-isolated panel.

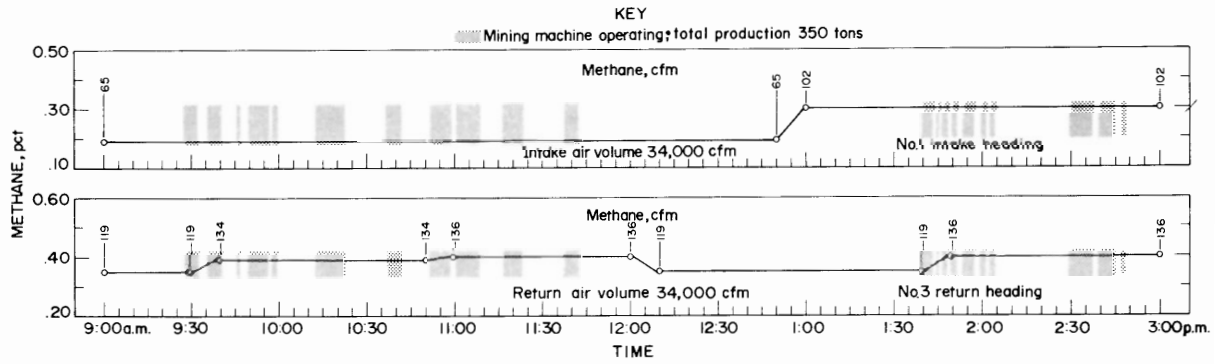

FIGURE 3. - Data from study area 4-isolated panel.

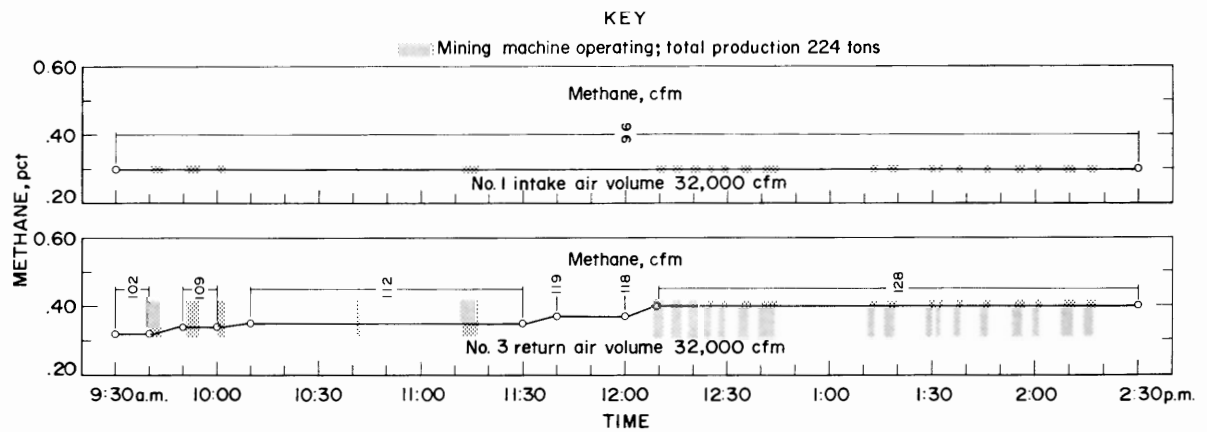

FIGURE 4. - Data from study area 8-isolated panel.

methane concentrations were measured at the last inby breakthrough to determine methane intake from other sections, main haulway, and the shaft bottom. Coal production was recorded in each study area.

RESULTS

Table 1 gives a summary of all pertinent data from methane emission studies in the isolated coal panel and in the two virgin areas. Particularly significant is the trend of methane emission as mining progressed in the isolated panel for a distance of 1,800 ft. Emission increased from 2.1 ft³ per ton of coal mined in study area 1 to 14 ft³ in study area 4 (800 ft from area 1), and decreased to 6 ft³ at the end of the next 1,000 ft in area 8. Undoubtedly, the emission rate would have decreased to nearly zero just before cutting through to the North airways (additional distance of 900 ft), because bleed-off to these headings had been in progress for 3-1/2 years when the studies were made. Cubic feet of methane per ton of coal mined was chosen as the unit of degasification because it is useful as an indicator of the low methane emission rate of the isolated panel relative to the virgin coal.

Figures 2 through 4 show the methane emission rates during a single shift for three particular study areas and figure 5 shows the emission rates for the six studies within the isolated coal panel.

Figure 6 shows that the continuous miner operating in virgin area 2 was stopped by the methane detector 19 times for a total of 36 min, due to the presence of 2 percent or greater methane concentration approximately 10 ft ahead of the operator. The average emission in cubic feet per ton of coal mined was 33.8 (table 1), or 3.7 times greater than that from the isolated panel. Similar stoppages of the continuous miner did not occur in study area 7 (2 South mains) because the coal production rate was only 88 tons during the study period.

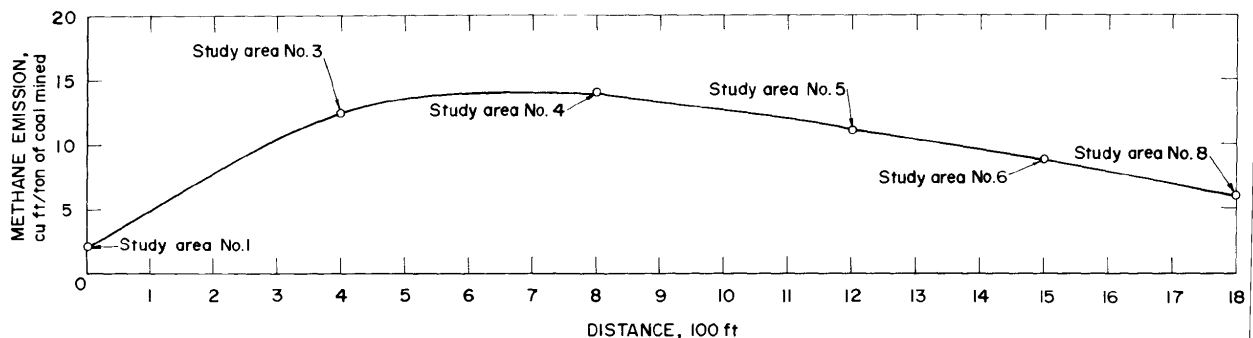

FIGURE 5. - Curve of methane emissions within an isolated panel.

TABLE 1. - Summary of pertinent data from methane emission studies in the isolated panel of coal and in two virgin areas, in 1972

Date of study	Number of study area ¹	Average total air volume, ² cfm	Average methane emission volume, cfm			Raw coal production, net tons	Continuous miner operating time, min	Total study period, min	Average methane emission, cubic feet per ton of coal mined	Remarks
			Intake	Returns	Total					
Feb. 23	1	38,000	75	6	81	330	113	270	2.1	Set of four headings.
Apr. 13	3	32,000	81	40	121	350	110	360	12.6	Set of three headings.
May 16.	4	34,000	80	52	132	350	94	360	14.0	Do.
June 14	5	32,000	88	30	118	207	76	360	11.0	Do.
July 20	6	35,000	87	17	104	203	104	330	8.7	Do.
Sept. 1	8	32,000	96	22	118	224	60	300	6.0	Do.
Mar. 22	2	³ 32,000	35	84	119	240	90	300	33.8	Set of six headings. ⁴
Aug. 7.	7	⁵ 35,000	⁵ 78	53	94	88	60	210	42.2	Set of seven headings. ⁶

¹All study areas, except 2 and 7, are in the isolated panel; study areas 2 and 7 in virgin coal.

²All study areas in isolated panel were ventilated with one split of air, except area 1 which had two air splits in four headings.

³Operating air split--two splits in section--total volume 79,000 cfm.

⁴Boring-type continuous miner used. Cut cross-sectional area of 80 ft².

⁵Operating air split--two splits in section--total volume 82,000 cfm.

⁶Ripper-type continuous miner used. Cut cross-sectional area of 100 ft².

NOTE.--Each area was studied during one operating shift. Air volumes in both active and idle splits were combined in study area 1 to more closely correspond to the three headings on the active air split in all other study areas.

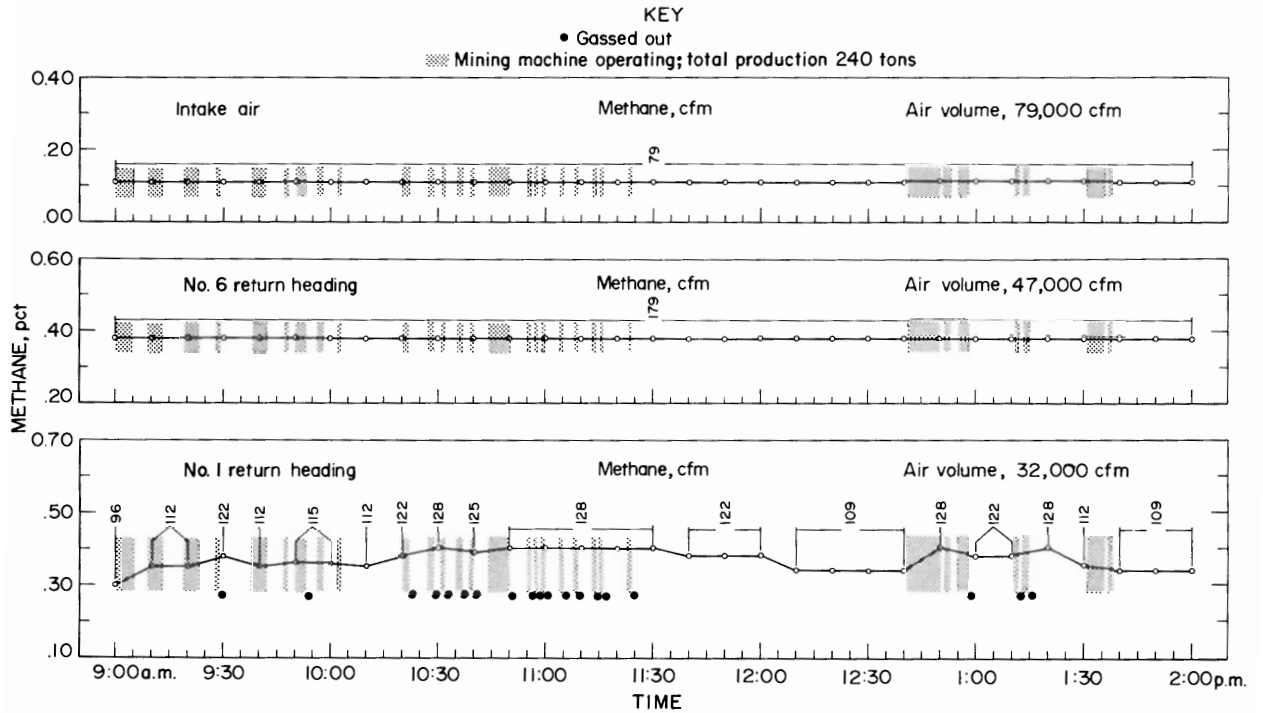

FIGURE 6. - Data from study area 2—development in 2 North mains—virgin coal.

Mining within a major coal panel in the Pittsburgh coalbed that had been completely isolated for 12 months showed a very significant reduction in methane emission rate per ton of coal mined. The average of 9.1 ft³ in all studies within the isolated panel is to be compared to 33.8 and 42.2 cft obtained when mining within the two virgin areas. This corresponds to a reduction in methane content of more than 70 percent. The average coal production rate in the isolated panel (3 tpm) could have been doubled without exceeding the allowable methane content in the return airway.

Although the above data appear to be adequate to assure the advantages of isolating a major coal panel, and hopefully many or most of the coal companies operating in the very gassy Pittsburgh coalbed will determine their own cost-effectiveness, the Bureau plans further studies. These will be conducted within partially isolated and unisolated panels, and in the development of sets of headings to isolate a major coal panel. Our objective is to determine the safety and cost-effectiveness with respect to methane, especially in the development of an isolated panel ahead of need and in mining four or five butt headings within the panel. Such data should be valuable for reaching a decision by any company operating in the very gassy Pittsburgh coalbed area.

CONTROL OF METHANE BY WATER INFUSION

by

J. Cervik¹ and A. Cetinbas²

ABSTRACT

Tests conducted in the Pittsburgh coalbed show that water infusion is an effective method of controlling methane at active faces of a section. Methane flows have been reduced ranging from 40 to 80 percent. The direction of the face cleat with respect to the direction of section advance is an important factor in determining the spacing of horizontal holes along the width of the section. No adverse effects on roof or floor have been noted.

INTRODUCTION

Water infusion or waterflooding of coalbeds in advance of mining is a method of controlling methane flows at active face areas during mining. Except for one piece of equipment, the technique can be applied with tools and equipment normally found in an operating section. In the Pittsburgh coalbed, a block of coal measuring about 150 by 500 ft in advance of the section can be infused over a weekend.

Coalbeds are naturally fractured and, therefore, one can characterize them as being made up of fractures and matrix (solid coal). Generally, there are at least two sets of vertical fracture systems that intersect at right angles. These two fracture systems are referred to as the face and butt cleats and form an interconnected network throughout the coalbed.

What part does the matrix (solid coal) play in the infusion process? The matrix contains a pore system that is interconnected. However, these pores are about the size of a methane molecule, which is too small to permit water to pass. Therefore, waterflooding of coalbeds is confined to the fracture system only.

The fracture density of coalbeds, which is defined as the number of fractures per inch or per foot, varies. A blocky coal such as the Pittsburgh is

¹Supervisory geophysicist.

²Mining engineer.

Both authors are with the Pittsburgh Mining and Safety Research Center, Bureau of Mines, U.S. Department of the Interior, Pittsburgh, Pa.

characterized by a fracture spacing of about 1/2 ft. The friable coals such as the Freeport and Pocahontas No. 3 are characterized by a fracture spacing of about 1/4 in. The property of a coalbed to transmit a fluid such as water is due to the fracture systems.

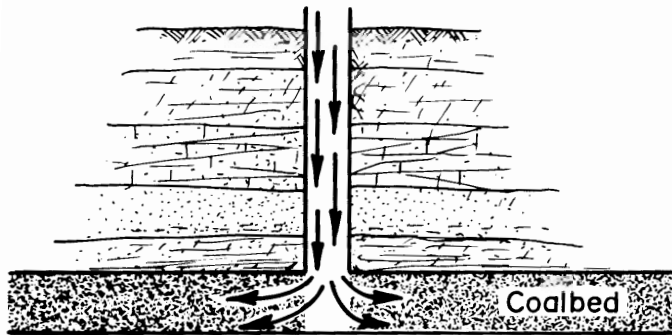

FIGURE 1. - Flow into coalbed through vertical borehole.

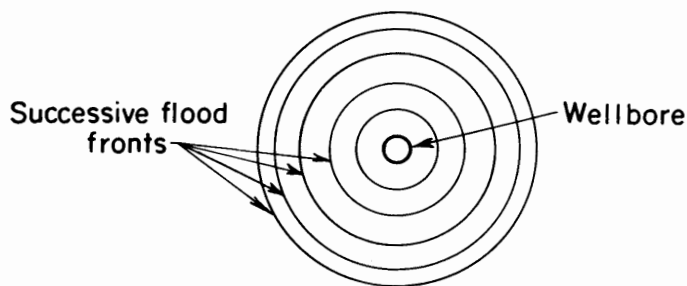

FIGURE 2. - Migration of water front through coalbed.

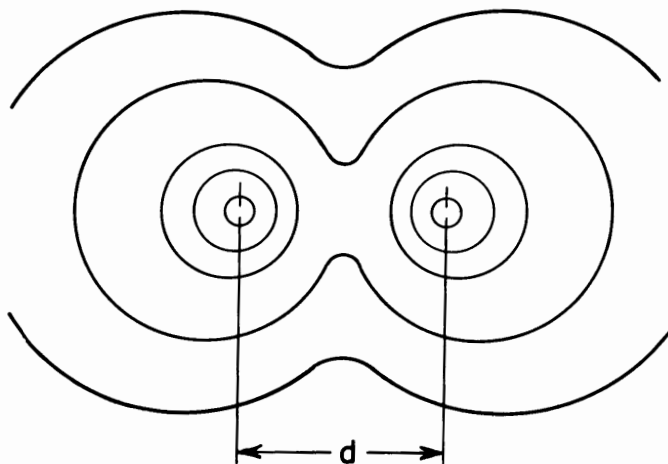

FIGURE 3. - Waterflood front of two wells.

Methane exists in both the fracture system and the micropore structure of the matrix. The bulk of the methane in coalbeds is stored in the micropore structure. The flow of methane from the micropore structure is a slow process as is evident by the fact that coal is mined, transported to the surface, stored in silos, or stockpiled with subsequent fires and explosions. On the other hand, less than 10 percent of the total methane content of a coalbed is stored in the fracture system. However, flow through the fracture system is a very rapid mode of transport and even though a small percentage of the total methane content of the coalbed is stored there, this is the source of methane that causes ventilation problems during mining. The successful application of water infusion depends to a large extent upon the permeability of the fracture system of the coalbed.

INFUSION OF COALBEDS

Water infusion of coalbeds is affected by several factors. Some can be controlled and others cannot. A discussion of these factors will help you to visualize and understand what happens when coalbeds are infused, precautions to be taken, and the effect on methane flows within the coalbed. Two waterflooding studies conducted under different conditions will be presented to illustrate the effects of some of these factors on methane flows at face areas during mining.

Figure 1 shows water being pumped down a wellbore and forced under pressure into a coalbed. The water flow rate will be governed by the water pressure in the wellbore and the fracture permeability of the coalbed. In order to simplify the discussion, we can assume that the permeability of the coalbed is constant and the same in all directions. Figure 2 shows a plan view of the migration of water through the coalbed under the assumed conditions. The water moves away from the wellbore uniformly in all directions. The circles in figure 2 show the successive positions of the water front with time. As water moves through the fracture system, it displaces the methane ahead of it.

Figure 3 shows a coalbed being flooded by two wells separated by a distance, d . The flood fronts from each well will eventually merge and continue as one oval front. If three or more wells are used, the resulting flood front will become oval shaped.

The preceding discussion is also applicable to horizontal holes drilled underground into coalbeds providing the infusion of the coalbed is from a small segment at the back part of the hole. This condition can be met by filling the horizontal hole with inflatable packers (fig. 4). If too few packers are used, the water tends to short circuit along the hole instead of penetrating into the coalbed. Good results are obtained when 5-ft packers are connected with joints of 5-ft pipes.³

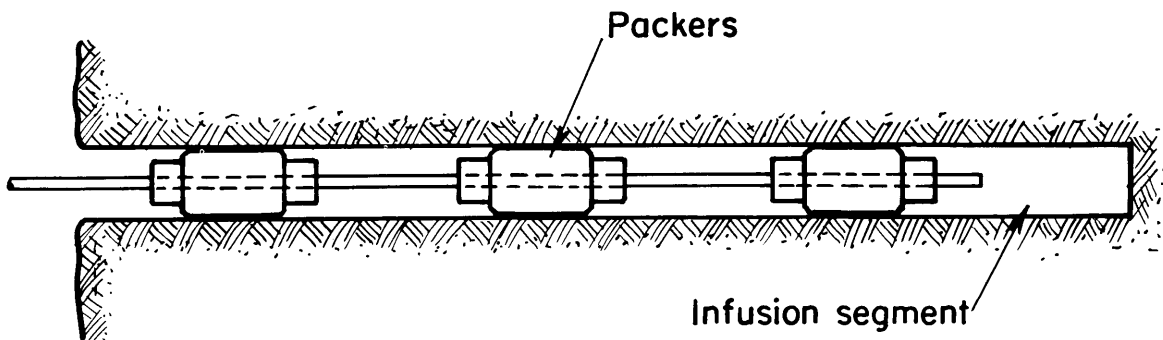

FIGURE 4. - Packed hole for waterflooding.

³Cetinbas, Abdurrahman, R. P. Vinson, Joseph Cervik, and M. G. Zabetakis. Methane and Dust Control by Water Infusion. Pittsburgh Coalbed (Fairview, W. Va.). BuMines RI 7640, 1972, 17 pp.

A typical section advancing into virgin coal may be about 500 ft wide. In order to reduce methane flows through the faces of the section, a continuous waterbank must be emplaced which spans the width of the section. The waterbank behaves like a barrier and prevents methane from flowing toward the faces of the section. Rather, it is directed around the water infused zone and enters the mine opening through the ribs outby the face areas of the section.

The emplacement of a waterbank across the section requires two or more horizontal holes. The number depends upon the length of the holes. Generally, horizontal holes 100 to 150 ft in length can be drilled using the hand-held equipment used underground. In some cases, entries are advanced in about 100-ft increments. Integrating a drilling and infusion phase using 100-ft holes into a mining cycle then presents no special problems.

In figure 5 is shown a schematic of the infusion of a coalbed using a packed horizontal hole. Successive stages of migration of the flood front are shown and when the front first reaches the mine opening, water begins flowing from the face and ribs. At this time the diameter of the flooded region is about 200 ft. Further infusion of the coalbed will expand the water infused zone as well as increase the flow of water into the mine opening. If water deteriorates the floor, infusion should be terminated when the flood front first reaches the mine opening or pumping facilities should be provided to dispose of the water.

The second hole should be drilled 140 to 170 ft from the hole shown in figure 5. The flood patterns of each hole will merge similar to those shown in the schematic in figure 3 when breakthrough occurs. This procedure is repeated with additional holes to produce a continuous waterbank across the section.

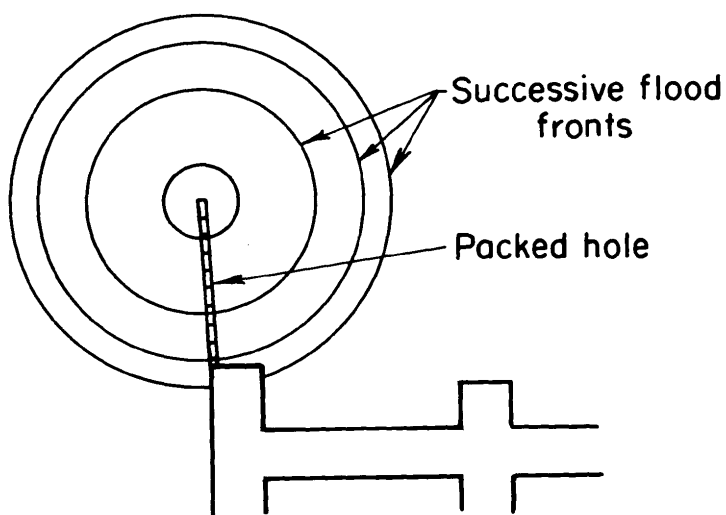

FIGURE 5. - Water infusion of coalbed using a horizontal hole.

There is no preferred sequence of infusing horizontal holes. They may be infused simultaneously or in sequence as they are drilled. The important aspect of the process is to leave no partially flooded or unflooded regions where methane can funnel through to the mine opening.

In reality, coalbeds such as the Pittsburgh exhibit strong directional permeabilities. For example, the face cleat permeability in the Pittsburgh coalbed is about 10 times greater than the butt cleat permeability. This difference in permeability affects

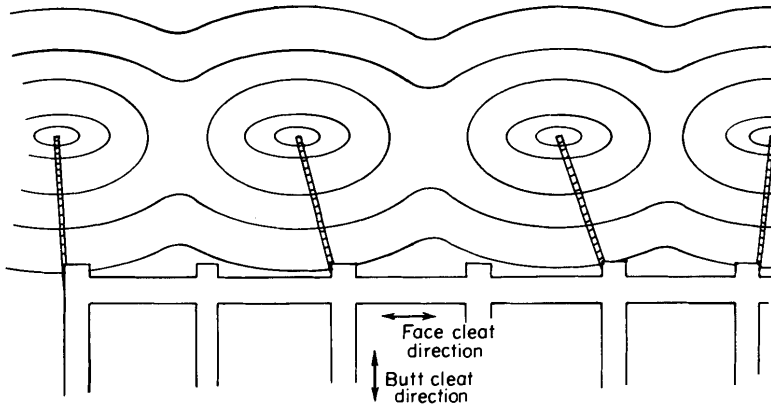

FIGURE 6. - Elliptical flood fronts for face cleat perpendicular to section advance direction.

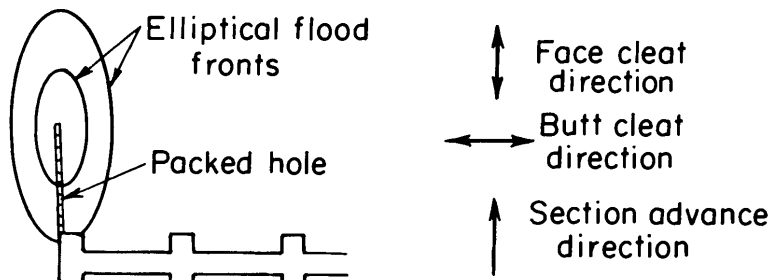

FIGURE 7. - Elliptical flood fronts for face cleat parallel to section advance direction.

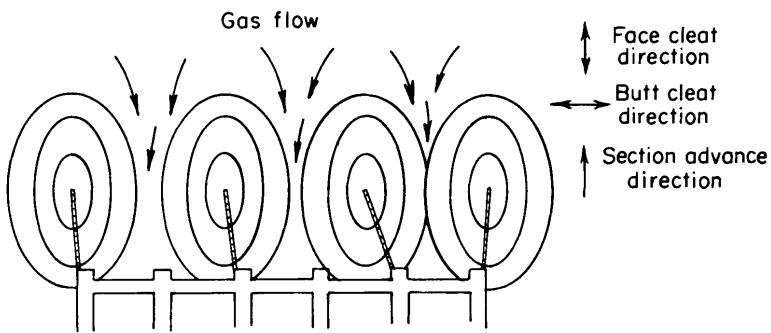

FIGURE 8. - Waterflooded section for face cleat parallel to section advance direction.

the shape of the water infused zone. The mine opening, which is about 100 ft from the infusion segment of the horizontal hole, has its effect on the shape of the infused zone as well as on the gas pressure in the coalbed, which increases with distance from the mine opening. The effect of these factors will be discussed briefly in the succeeding paragraphs.

Directional Permeabilities

When the permeability of the butt cleat is appreciably different from that of the face cleat, the successive stages of the waterflood front do not have the circular shape shown in figure 5, but will be distorted into an elliptical shape. In the case of the Pittsburgh coalbed, water will migrate faster along the face cleat than it does along the butt cleat.

In figure 6 is shown a schematic for the case where the more permeable face cleat is perpendicular to the direction of advance of the section. This is an ideal situation because the water tends to run across the section. Four equally spaced holes across a 500-ft section will emplace a waterbank free of unflooded or partially flooded regions.

If the face cleat is in the direction of advance of the section, the successive stages of the flood front are shown schematically in figure 7. Note that the distance of migration of the flood front at breakthrough is much less across than in the direction of advance of the section. Drilling and infusing four holes across a 500-ft

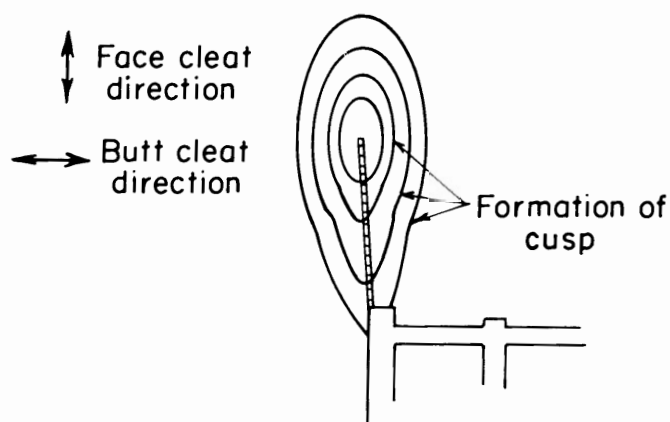

FIGURE 9. - Cusping of flood front.

critical for the case shown in figure 6 as it is for the case shown in figure 8. As the flood front migrates toward the mine opening, the elliptical shape is distorted, this distortion is called cusping.⁴ Figure 9 shows the cusping of successive stages of the flood front as it travels toward the mine opening. This effect causes premature breakthrough of the waterfront and a corresponding decrease in lateral migration.

Effect of Gas Pressure in Coalbed

Gas pressure increases with distance into the coalbed. Therefore during waterflooding operation, the flood front furthest from the mine opening experiences a greater resistance to flow than that closer to the mine opening. Because of the low gas pressure in the Pittsburgh coalbed at a depth of 100 ft (less than 30 psig), distortion of the flood front due to gas pressure is not expected to be as pronounced as the effects of the mine opening or directional permeabilities. However, in other coalbeds such as the Pocahontas No. 3⁵ where a gas pressure of about 600 psig exists at a depth of 100 ft into coal, this effect could be as important as the mine opening or directional permeabilities effects.

CASE STUDIES IN THE PITTSBURGH COALBED

Two case studies were conducted in the Pittsburgh coalbed under similar conditions. The difference between the two tests was the direction of the more permeable face cleat with respect to the direction of section advance.

Figure 10 shows a schematic of a test section. The section in both cases was about 500 ft wide and in the first case a six-entry system was being driven and nine in the second case. Both used a split system of ventilation.

⁴Muskat, M. Flow of Homogeneous Fluids Through Porous Media. J. W. Edwards, Inc., Ann Arbor, Mich., 1st ed., 1946, pp. 468-472.

⁵Kissell, F. N., and R. J. Bielicki. An In Situ Diffusion Parameter for the Pittsburgh and Pocahontas No. 3 Coalbeds. BuMines RI 7668, 1972, p. 3.

section may result in an infused zone shown schematically in figure 8. Zones exist between holes that may not have been swept by water. These zones permit methane to bleed through to the faces of the section, and thereby reduce the effectiveness of the blocking action of water.

Effect of Mine Opening

The close proximity of the infusion segment of the horizontal hole to the mine opening affects the shape of the flood front, although the effect is not as

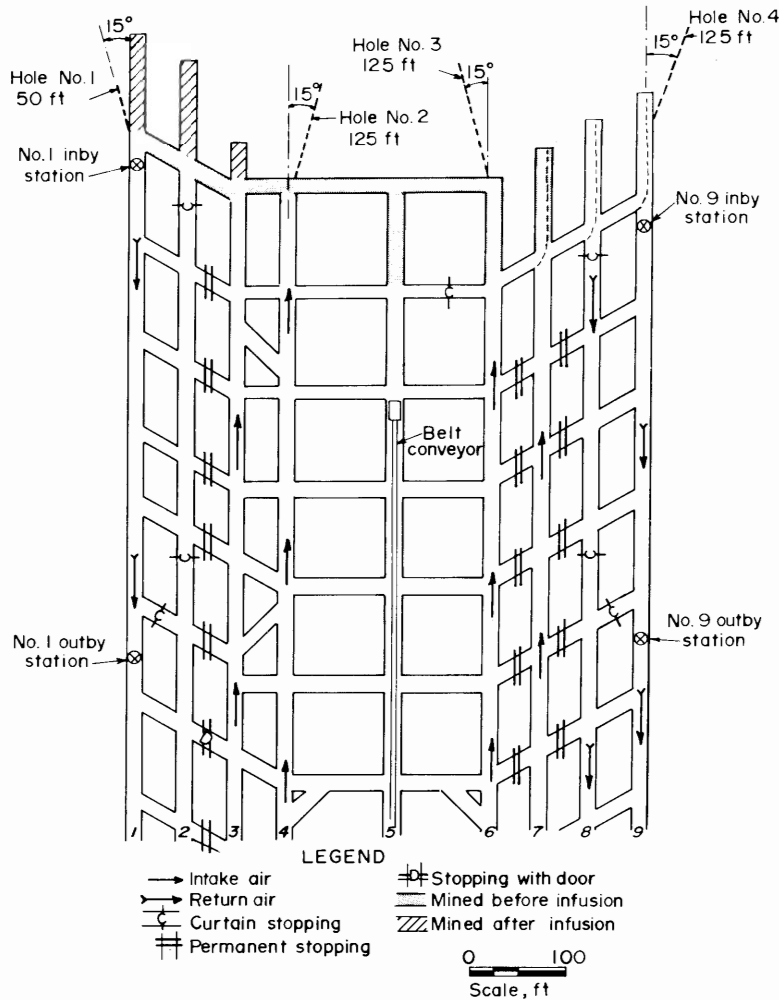

FIGURE 10. - Location of horizontal holes, monitoring stations, and ventilation plan.

Four horizontal holes, about 125 ft deep, were drilled across the section; one in each outside return, and two others spaced across the inside entries. Each hole was angled a few degrees off the projected development of the entry and infused with about 8,000 gal of water at pressures ranging from 275 to 410 psig.

Methane recording instruments were set up in the immediate returns. These instruments are referred to as the inby instruments and their sum gives the total methane flow rate from the faces of the section. Two other sets of instruments were set up in the returns about 600 ft outby the faces of the section and these instruments are referred to as the outby instruments. The sum of the two outby instruments gave the total methane flow rate from the faces of the section and the two outside ribs. The difference between outby and inby methane flow rates is the flow rate of

methane through the two outside ribs of the section.

The first test was conducted in a section where the more permeable face cleat was at right angles to the direction of section advance. Referring to figure 7, this is an ideal condition because water tends to run across the section faster than toward the mine opening. A continuous waterbank is emplaced across the section and no zones exist where methane can funnel through. Figure 11 shows the effect of the waterbank on methane flows at the face areas during mining.

The methane flow rate from the faces of the section (inby curve) averaged 132 cfm before infusion and 28 cfm after infusion. The average flow rate was thus reduced approximately 79 percent. The average methane flow rate at the outby stations decreased from 243 before infusion to 166 cfm after infusion, a decrease of about 32 percent.

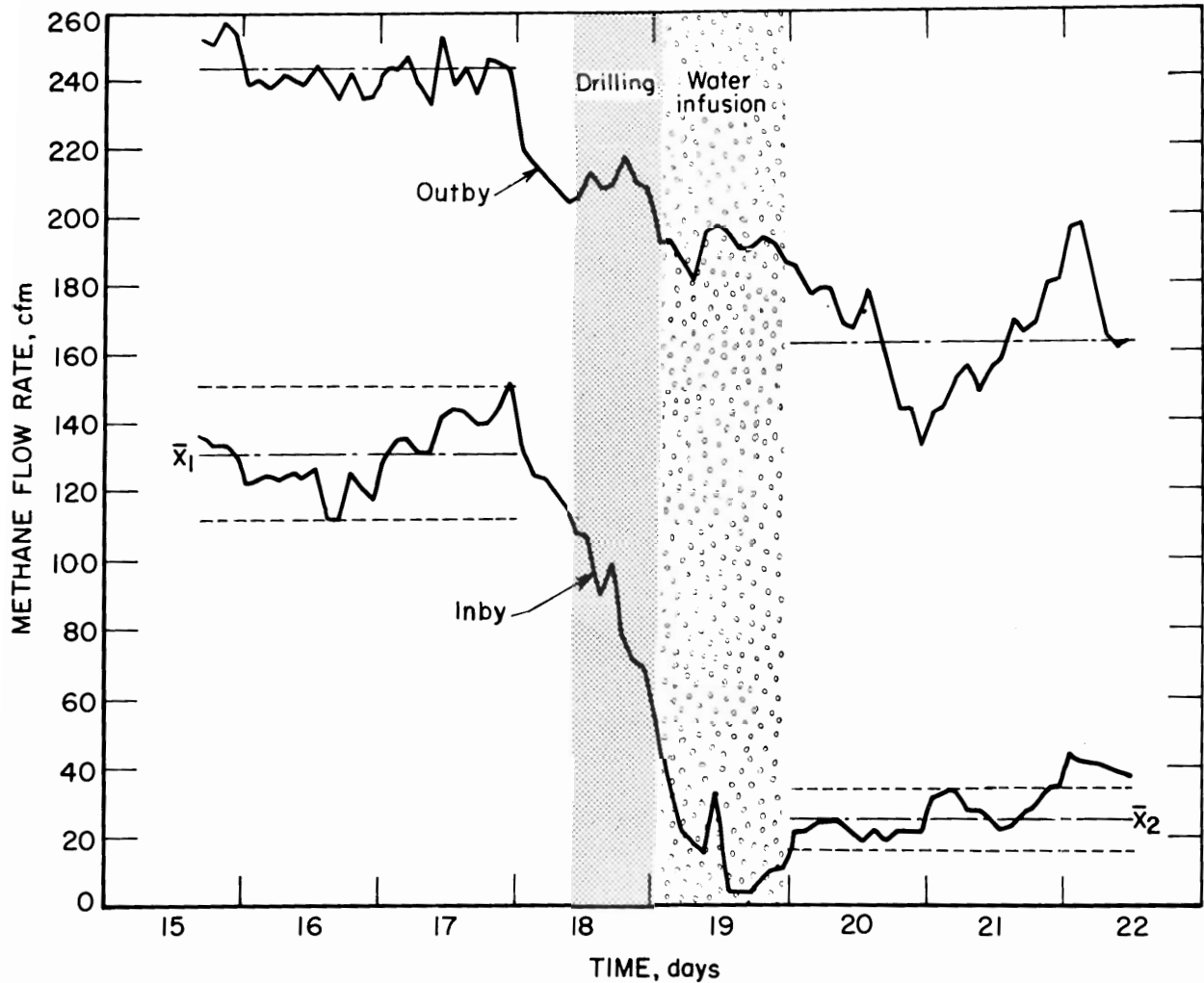

FIGURE 11. - Total methane flow rates from study area where face cleat direction is perpendicular to section advance direction.

The difference in methane flow rates between outby and inby stations represents the quantity of methane entering the mine opening through the two outside ribs. Before infusion, 111 cfm is entering through the ribs. After infusion, 138 cfm is entering through the ribs which represents a 24-percent increase. These data show that the emplaced water is diverting methane from the face areas of the section to the outside ribs.

The second test was conducted in a section advancing parallel to the more permeable face cleat. Referring to figure 8, the infused water tends to run in the direction of section advance faster than across the section. Consequently, zones may exist between holes which have not been filled with water. These zones permit methane to funnel through to the faces of the section. Figure 12 shows the results of the infused water on methane flows for this case.

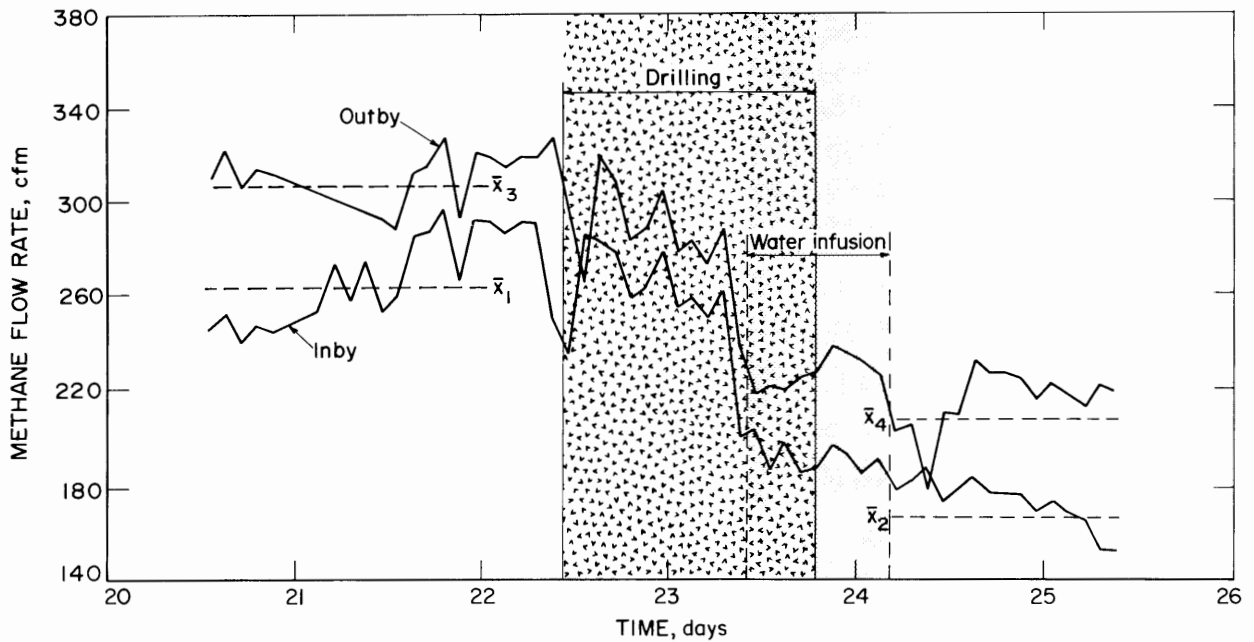

FIGURE 12. - Total methane flow rates from study area where face cleat direction is parallel to section advance direction.

The average methane flow rate from the immediate face areas of the section (inby curve) before infusion is 265 and 165 cfm after infusion. This represents a 38 percent reduction in methane flow rate. At the outby stations, the methane flow rate dropped from 306 cfm before infusion to 208 cfm after infusion and represents a 32-percent reduction. The difference in flow rate between outby and inby curves before infusion is 41 and 43 cfm, respectively, after infusion. These differences are not significant and indicate that methane is not being diverted from the face areas to the outside ribs.

To improve the effectiveness of water infusion in the second case, two alternatives can be followed. First, hole depth can be increased to about 200 ft. The infused water would tend to migrate further across the section before breakthrough occurs when compared with the case using shorter holes. Secondly, hole depth would remain the same, but the number of holes drilled across the section would be increased to six. Each of these alternatives tends to produce a continuous waterbank across the section.

Mining Through an Infusion Hole

After infusion has been terminated, the inflatable packers are removed and the hole is plugged at the collar to prevent infused water from draining out. Intercepting a water infusion hole during the mining of a crosscut does not create an unsafe condition because flow from the hole is water. Mining into a water infusion hole, although not expected to create unsafe conditions, is avoided by drilling all holes 5 to 10 degrees off the projected development of the entry.

Effect of Water on Roof and Floor Strata

A consistent argument heard throughout the coal industry is that infusing water into a coalbed causes roof and floor problems. However, there are arguments to show that this is not the case.

Experience has shown that accumulations of water on a soft bottom does create haulage problems. Accumulation of water occurs during the drilling of horizontal holes, when the flood front breaks through at the face and ribs, and from the spray system of the miner. However, the effects of water on a soft bottom from these sources can be minimized by channeling the water, installing pumps, and disposing of the water before large accumulations occur.

Most coalbeds contain inherent water that is stored in the fracture system. Horizontal holes drilled 400 to 500 ft in advance of mining produce water at persistent rates of 700 to 900 gpd in the Pittsburgh coalbed. These flows are observed even in sections that are considered "dry." Vertical boreholes drilled into virgin coal in coalbeds throughout the United States must have water pumps installed to clear the wellbores of water in order to maintain gas production. Therefore, just as methane is normally associated with coal, one can add water to the system.

Because water does not wet coal and gravity, water is assumed to be in the bottom part of the coalbed. Observations show that the bottom 1 ft of coal along an outside entry is wet and the remainder of the coal is generally dry. If the bottom is in contact with inherent water, infusion of water into a coalbed does not create conditions that have not existed for ages. Therefore, there is doubt that water infusion will affect even a soft bottom.

The exposure of roof rock to water during infusion is not expected to produce any effect that would weaken and cause roof failures. The roof is in contact with the infused water only where fractures in the coalbed terminate at the roof. Fracture widths in coalbeds range from perhaps 1/16-in to hair-line cracks. For a blocky type coal such as the Pittsburgh, the area of water contact with the roof is small in comparison to the areal extent of the infused zone.

In some instances, parting occurs along the coalbed-roof interface. In this case water wets the roof completely. However, this parting exists around the mine opening and probably does not extend beyond 10 to 15 ft into the coalbed.

No roof or floor problems have been observed due to water infusion. In one case haulage was affected in an area where drill water and breakthrough water accumulated and was absorbed in the bottom. However, there are means of avoiding this situation.

INFUSION IN DEEP COALBEDS (1,500 TO 2,000 FT)

Infusion pressures in the Pittsburgh coalbed range from about 275 to 410 psig and infusion rates range from 8 to 20 gpm. In other coalbeds such as the

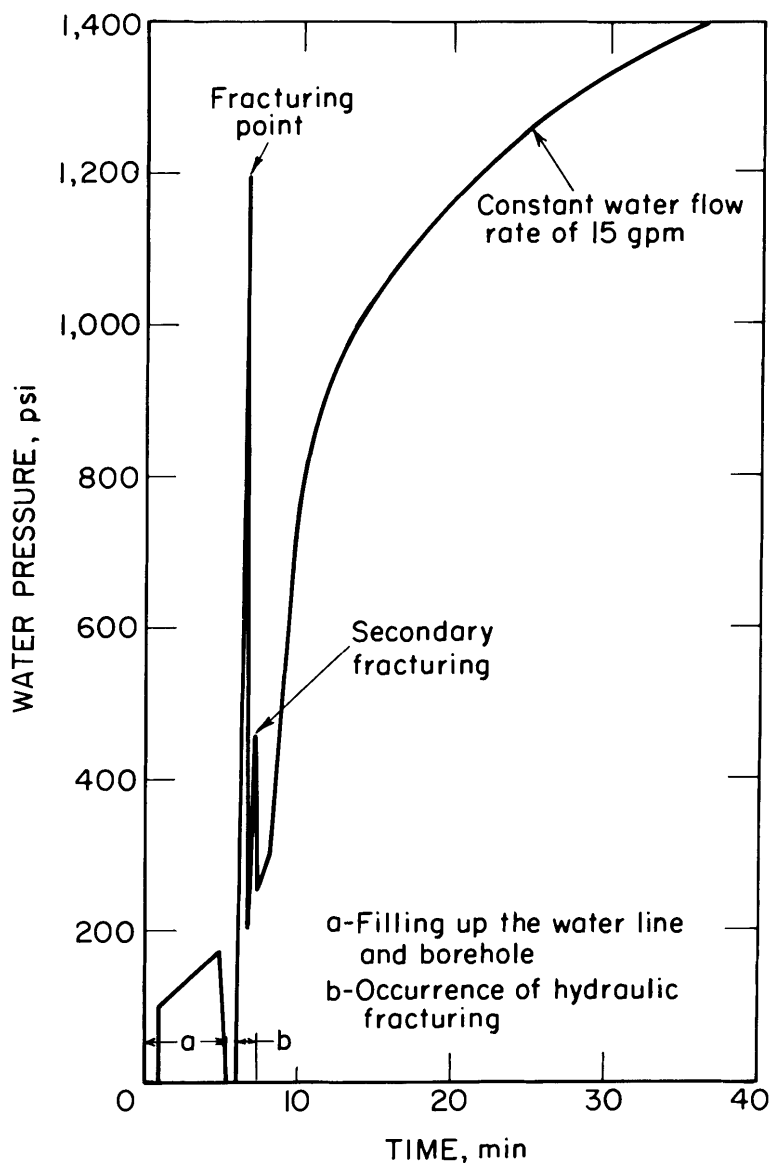

FIGURE 13. - Hydrofrac of horizontal hole.

Pocahontas No. 3, gas pressure at a depth of 100 ft is about 600 psi. Consequently, infusion pressures in excess of 600 psi are required. There are, however, other problems associated with deep, friable type coalbeds that need to be solved before water infusion can be successfully applied. Bureau tests conducted in the Pocahontas No. 3 coalbed showed that water infusion rates at 1,200 psi infusion pressures are less than 0.6 gpm, which is too low to integrate the infusion phase into the mining cycle.

There are possibly two reasons for the low infusion rates in the Pocahontas No. 3 coalbed. First, the permeability of the coalbed is extremely low in which case there is not much one can do to improve the infusibility of the coalbed. Secondly, because of the friable nature of the coal and overburden pressures, the coal surrounding a horizontal hole becomes impermeable or suffers a partial loss of permeability. Under these conditions, gas flow out of the hole and infusion of water into the coalbed are inhibited. In the oil

industry, this effect is called borehole damage and in some cases a hydrofracing process is used to increase the permeability of the damaged zone.

Hydrofracing is a process whereby the pressure in the wellbore is raised very rapidly until the formation fractures. When this occurs there is an abrupt drop in wellbore water pressure.

A hydrofrac experiment was attempted to determine if a zone of reduced permeability surrounds horizontal holes drilled into the coalbed. A 1-in pipe was grouted to a depth of 195 ft in a 200-ft hole. The gas flow rate from the 5 ft of open hole was 300 cfd.

Figure 13 shows the pressure history in the hole during the test. The waterlines and hole were initially filled with water. Then the water pressure in the hole was raised very rapidly. Fracturing occurred at about 1,200 psi followed by an abrupt drop in water pressure. A secondary fracture occurred shortly afterwards. Water flow rate into the coalbed after the frac treatment was 15 gpm which was the maximum capacity of the pump. Gas flow monitored from this hole about 1 month later was 13,000 cfd. Both water infusion and gas flow rates were improved.

CONCLUSION

Waterflooding is an effective method of controlling methane at active face areas and thereby improving the safety conditions in an operating section. We have attempted to present the mechanics of water infusion in a simplified fashion so that those associated with production of coal and not necessarily familiar with fluid dynamics might have a better understanding of the process. I hope that this presentation will be helpful in diagnosing and solving problems associated with the application of this technique by mine personnel.

DEGASIFICATION OF A COAL SEAM—LONGWALL GOB AREA

by

P. A. Ferguson¹

ABSTRACT

Thirty-five boreholes have been drilled into longwall panels and conventional pillar sections of the Bethlehem Mines Corp.'s mines Nos. 32 and 33 operating in the Lower Kittanning seam near Ebensburg, Pa. These have been found useful in reducing the methane in the returns and now handle up to 80 percent of the methane from pillared areas. As expected, mining rates have increased in these mines.

INTRODUCTION

Bethlehem Mines Corp., Cambria Division, is located in Cambria County, Pa., near Ebensburg. Mines Nos. 32 and 33 are operating in the Lower Kittanning or "B" seam and are mining down the west flank of the Wilmore syncline. The lower coal measures in this area are all gassy and the cover over the B seam varies from 500 to 1,000 ft.

The immediate overlying strata is of the Pennsylvanian age and consists of carbonaceous shales, argillaceous carbonaceous sandstones, coals, and some argillaceous limestones. Studies have shown that methane can be drawn from the upper coal seams: The Upper Freeport (E), Lower Freeport (D), Upper Kittanning (C'), and Middle Kittanning (C).

Mine No. 33 was opened in September 1964 by driving a slope on a 30-percent grade 2,700 ft to the B seam. Ventilation was established with a return shaft and then entries were driven to the Cambria Portal shaft for additional intake air. Small quantities of methane were encountered during entry development and averaged approximately 500,000 cfd. Three exhaust fans presently handle the ventilation requirements of the mine, discharging a total of approximately 900,000 cfm.

The first pillar extraction began in December 1966 and methane liberation increased to approximately 2 million cfd 2 months after pillaring had started. After 4 months of pillaring in two headings, methane liberation reached a high

¹General Superintendent, Cambria Division, Bethlehem Mines Corp., Ebensburg, Pa.

of 3,380,000 cfd. This substantiated that the fracturing and caving of the upper strata was liberating large volumes of methane into the mine.

First mining in this seam was known to be very costly because of extensive roof pressures and high caving, and the possibility of limited pillar production because of large quantities of liberated methane in the mine made necessary a detailed study of the mining projections and tonnage requirements. This study initially centered around ventilation, power requirements, and air shaft locations since larger quantities of air would be needed as mining progressed.

METHANE CONTROL

The study of the methane problem at mine No. 33 was started in January 1968. We found that there was an apparent correlation between the methane liberation rate from pillared areas and the coal production rate and gob area exposed during mining. This study also showed that exhausting this methane through the mine ventilation system would be very costly because of the need for additional shaft installations, airway maintenance, and increased quantities of air.

On March 28, 1968, the U.S. Bureau of Mines, Pittsburgh Mining Research Center, contacted us and proposed a study at mine No. 33 as follows:

1. An analysis of cuttings from a churn drill hole would be made with a log of the strata. Samples would be taken on 5-ft intervals, starting at the Lower Freeport D coal and including all coal formations below this to the B coal.
2. These data would be used to determine an approach to be used in this mine.

Three holes were subsequently drilled in February 1971--one 95 ft horizontally into the seam, one 38 ft at 39 degrees up from the horizontal, and one 33 ft vertical. Pressure measurements made at various locations in the holes showed low gas pressures with minimal flows. These studies by the Bureau substantiated our findings that the methane is contained in overlying strata which has a high porosity but low permeability. The methane is stored in the rock and the resultant exposure of surface area from caving provides a means for the methane to be liberated into the mine.

At this time, we were also concerned about the concentrated pillar tonnages being planned for our first longwall face and decided to drill a drainage borehole from the surface into the solid coal near the center of the longwall face. A rotary air drill was used to start this hole on March 19, 1968. This borehole (No. 1) was drilled 594 ft into the B seam and reamed to a 12-in diameter. An 8-in casing with the two bottom joints slotted was set in the hole, and the bottom of the pipe stopped at the C seam approximately 29 ft above the B coal. The hole was packed off above the upper slots and then grouted.

The hole was approximately 675 ft ahead of the longwall face when completed, and a 170-cfm vacuum pump was installed on the surface. Trial runs of this pump in the solid produced approximately 250 cfd at 80 to 90 percent methane before flow would stop at a vacuum of 20 in of mercury.

The longwall face cut into the borehole on June 18 and the pump operated at full flow with a vacuum of 1 in of mercury; methane was not present in the pump exhaust. On the following day, June 19, the face had advanced 16 ft beyond the hole and the exhaust gas was found to contain methane. Continuous pumping for 1 month averaged 150 cfm or approximately 210,000 cfd at 89.5 percent methane; this procedure was used to remove 4.8 million ft³ of methane from the mine (average: 172,000 cfd). At this point, we decided to try a larger pump of the same design capable of delivering 700 cfm and pumping was stopped to make the changeover. Interestingly, we discovered the hole developed a natural flow of 215,000 cfd of methane, indicating the smaller pump had actually restricted flow from the hole. The larger pump was put into operation and evacuated an average of 335,000 cfd of methane for 4 months or 35.8 million ft³ of methane.

In an attempt to evaluate the effect of this drainage on the mine ventilation system, the pump was shut down for a 24-hour period and the increased methane volume in the returns was found to be approximately equal to the methane previously exhausted by the pump. We, therefore, concluded that the borehole was removing methane that would otherwise be carried in the returns.

Since our first borehole was put into operation in June 1968, we have put eight drainage boreholes into service in mine No. 32, and 27 in mine No. 33. Of these 35 boreholes for the two mines, 27 were in longwall panels and eight in conventional pillar sections. Variations were tried in methods and equipment in several of these holes. However, rather than describe each installation, a summary of the experiments and our conclusions is given in the following paragraphs.

At an early stage, we recognized that freezing problems would be encountered with the water in the original vacuum pump; also, the high horsepower requirements and low efficiency made it undesirable for this application. We have since incorporated a 7-1/2-hp, 1,500-cfm blower of aluminum construction as a pumping medium. While this blower is rated for 1,500 cfm at 10 oz pressure, by changing the impeller and front cover it will deliver 1,660 cfm at 20 oz pressure. These latter impellers are installed on holes in active longwall panels. Then, as the panel is mined out, these are replaced with the original impellers as the methane concentration in the exhaust falls off.

The borehole depth has been varied to evaluate the effects of depth on methane liberation. We have stopped the hole above the B seam on several occasions and found these holes were also successful. Presently, holes are still being drilled into the B coal, and the bottom of the casings are stopped approximately 125 to 130 ft above the seam.

Packer locations have been varied in an attempt to stay below the water-bearing strata and to try to bleed off the methane from the highest possible

point in the cavity created by caving in the mine. We now locate a packer on the end of the 8-in casing which is set from 20 to 40 ft above the C' seam (120 to 140 ft above the B seam). The hole is then grouted for about 75 ft above the packer. This method eliminates the problem of the borehole casing extending into the C' coal and concern for the casing in future mining in this seam.

Our standard borehole is 12 in. in diameter; this hole is cased with an 8-in steel pipe. However, we are giving some thought to experimenting with both larger and smaller boreholes. A study will be made to determine the advantages and disadvantages of these compared to the boreholes now in use.

We have also vented the space between the 12-in hole and the 8-in casing to the atmosphere in order to bleed off any methane induced by cracks in the strata above the level at which the hole is grouted. To date, this has produced up to 230,000 cfd by free flow for one vent pipe in addition to the methane extracted by the pumps.

General safety precautions taken during the drilling and casing operations, and the operation of the drainage pumps are:

1. Blowers are never operated when the methane percentage drops below 25 percent.
2. Discharge pipes at the boreholes are kept a minimum of 15 ft above the ground.
3. Drainage holes in accessible areas are fenced and warning signs are placed around all sites.
4. All active boreholes are visited at least once daily and checks are made of the equipment and flow coming from the hole.

Our studies have shown that methane liberation as related to pillar tonnage varies from 0.29 to 1.42 cfm of methane per ton of coal mined in pillars. The use of drainage boreholes has reduced the amount of methane handled in the returns of the mine to the range 0.15 to 0.89 cfm per ton of coal mined. This shows we are now handling up to 80 percent of the methane liberation from pillar areas through the drainage boreholes.

CONCLUSIONS

The methane drainage boreholes have proved to be a safe and effective method of removing large quantities of methane from the mine atmosphere. This reduction has allowed mining to progress at maximum rates with a substantial reduction of methane content in the bleeder returns of the mines. This increases materially the coal production by utilizing high-cost, rapid-mining equipment more efficiently.

The methane drainage boreholes have proved so beneficial that additional holes are normally planned as part of our mine projections for methane drainage from pillar production areas of both longwall and conventional systems.

GOB DEGASIFICATION RESEARCH—A CASE HISTORY

by

J. G. Davis¹ and S. Krickovic²

ABSTRACT

A degasification hole was drilled in advance of mining over the longwall panel at the Blacksville No. 1 mine early in 1972. This well was especially designed to provide research data on gob gas control as part of a Bureau of Mines contract³ with Consolidation Coal Co.

Drilling and completion procedures are described, and research procedures and techniques are discussed. The latter include the use of wire line well logs to define overburden lithology, radioactive bullets in the side of the hole to trace subsidence, and use of a unique flow detector to locate points of gas entry into the well bore.

Performance of the hole and its effects on the panel bleeders is traced from the start until the mine was sealed following a fire in the summer of 1972.

ACKNOWLEDGMENTS

Valuable suggestions and technical assistance concerning test procedures were received from the Continental Oil Co.'s research department in Ponca City, Okla. Messrs. R. H. Minor and Herman Liddle of Consol's Blacksville No. 1 mine were very helpful in arranging for the underground part of the study. A portion of the data presented here was obtained by Mr. Raymond Mazza of Conoco, who is now conducting the field research under this contract.

INTRODUCTION

Early in 1972, Consolidation Coal Co. (Consol) initiated a research program in cooperation with the Bureau of Mines to study methane control in gob areas. Of particular interest were the development of efficient techniques for the removal of gas from newly pillared areas and from older gob.

¹Field Research Superintendent, Continental Oil Co., Morgantown, W. Va.

²Supervisory mining engineer, Pittsburgh Mining and Safety Research Center, Bureau of Mines, U.S. Department of the Interior, Pittsburgh, Pa.

³Contract No. H0322851.

Attention centered on the use of vertical holes drilled from the surface since this approach has the potential of removing gas from the mine in the most direct manner. A series of field experiments was designed to reveal sources of gas in the overburden, the gas flow network that forms as gob is formed, and changes that occur in both source and flow path with time.

The total program was divided into two phases. In the first, a study was to be made of gas control in new gob where holes could be drilled safely over solid coal slightly in advance of mining. In the second, studies would be made in older gob where explosive gas mixtures might exist and safe drilling techniques require development. In the first study, an analysis was made of the data obtained from 15 holes drilled earlier for gob gas control in Consol's Christopher Division. Additional tests were conducted on several of these holes, and four new holes were drilled in advance of mining for special study. These new holes, which probably contain the material of broadest general interest, are the subject of this presentation. The first of these will be discussed in detail. The second has been completed but not yet pillared under.

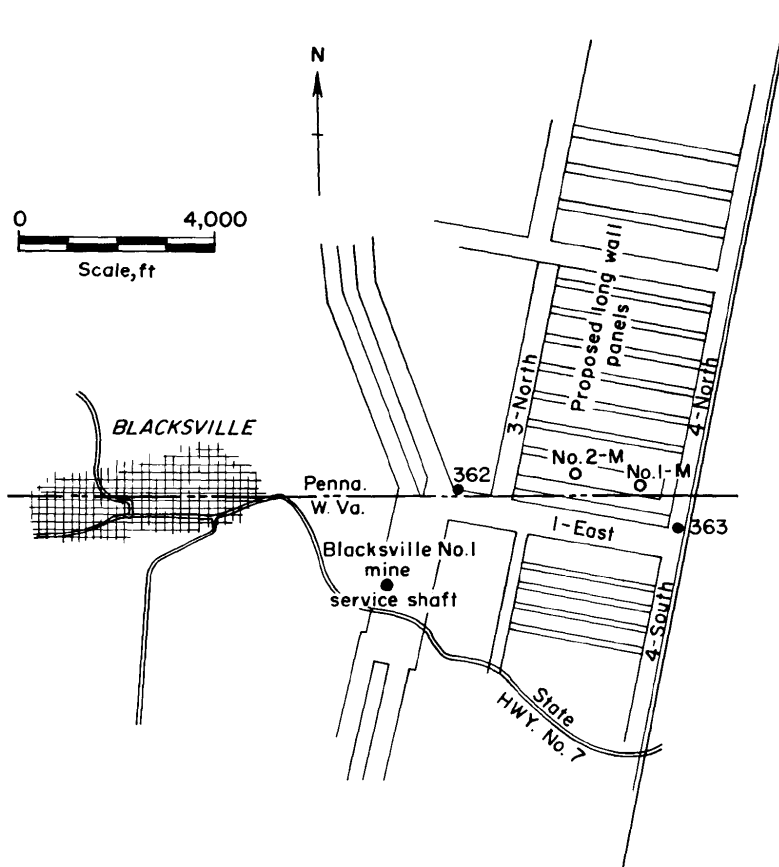

FIGURE 1. - Outline of Blacksville No. 1 mine in area of methane research wells.

EXPERIMENTAL

The first new test hole (No. 1-M) was drilled in advance of the longwall at Blacksville No. 1 mine (fig. 1). This area was selected because the mine was new and only development work had taken place. Consequently, the overburden was still undisturbed, and the test would not be affected by previous subsidence. Also, the data would be available for comparison later with that from more common room and pillar mining.

The general plan for these test holes was as follows:

1. Drill to the vicinity of the Waynesburg coal seam. Set and cement casing to exclude the upper water zones.

2. Core, drill, and test various intervals in

the overburden from the bottom of the casing to a point about 30 ft above the Pittsburgh coal.

3. Run a suite of wire line logs.
4. Implant radioactive bullets in the wall of the open hole and log these to establish index points for future subsidence studies.
5. Run a slotted liner to prevent caving of the open hole section.
6. Conduct subsidence and gas flow tests for 1 year or more after the hole is mined under.

The hole was located about 480 ft from the start of the 2,700-ft long and 430-ft wide panel. Mining had not yet started on the longwall proper when the hole was drilled.

Past experience gave no reason to expect any gas flows above the Waynesburg coal that could affect the mine. Consequently, a 9-5/8-in casing was set just above the Waynesburg and cemented to the surface. All drilling, both above and below the Waynesburg, was done with air.

The original plan had been to cut a 4-3/8-in-diameter core through most of the interval between the Waynesburg and the Pittsburgh. This would be used to aid interpretation of the wire line well logs. Coring was very slow, however, and the decision was made to drill ahead to a point just above the Sewickley coal before coring was resumed. It was still desirable to get the lower core, since this is the immediate overburden to the mine and a probable source of mine gas. Four drill stem tests were run so that the entire hole section below the casing was tested at one time or another. There was no significant show of gas at any point, although there were some very weak blows. There was no pressure buildup on any of the tests. Some water was observed, and the rate of water inflow when the well was at total depth was 0.05 gpm from the Waynesburg coal and 0.10 gpm from the Sewickley coal.

Two wire line logs were run at total depth. One was a combination gamma ray and side wall neutron. This log's fundamental use is for estimating formation porosity, but it is also very useful in determining formation lithology. For instance, shale will show a very high porosity and so will coal. They can, therefore, be picked from the less porous limestone and sandstone. Shale contains radioactive materials, however, and gives a high gamma ray count. Because coal is not radioactive, coal and shale can be separated from each other.

The other log was a combination gamma ray and formation density. This records rock density which is useful in determining lithology and in serving as an aid in the interpretation of the neutron log.

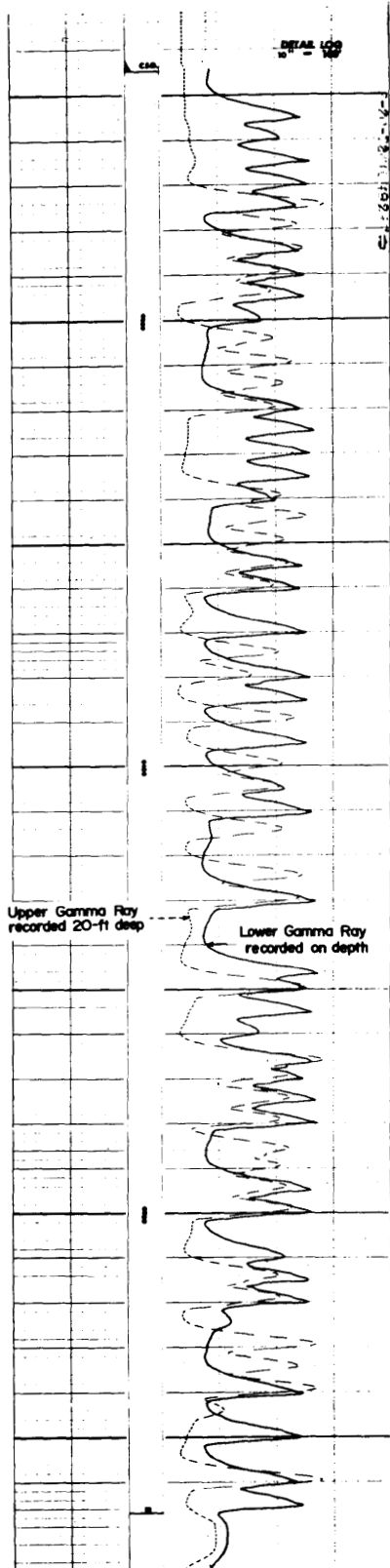

FIGURE 2. - Gamma ray log of cobalt tracer bullets immediately after test hole completion.

Rate of penetration, or "drilling rate," was recorded using a Geolograph.⁴ This record correlates very closely with the type of rock being drilled and is an aid in identifying individual zones.

Implantation of the tracer bullets followed the logging. These were ogival steel bullets, 1-3/4-in long and 9/16-in base diameter weighing about 30 g. Each contained Cobalt 60 tracer in a sealed cavity. The bullets were loaded into a multishot gun, which could be run in the hole on a wire line and the shots fired selectively.

An attempt was made to implant one bullet in each 5-ft section of open hole below the cemented casing. These later serve as index points by which

movement of the formations could be detected when subsidence occurred. A number of the bullets did not stay in place, probably because of extra hardness of the zone (dolomites or dense limestones). Others deflected slightly and were off by a foot or so. A special gamma ray log was run to locate the bullets for permanent record. Bullets show up as extremely high, sharp gamma ray peaks. A section of this log is shown in figure 2.

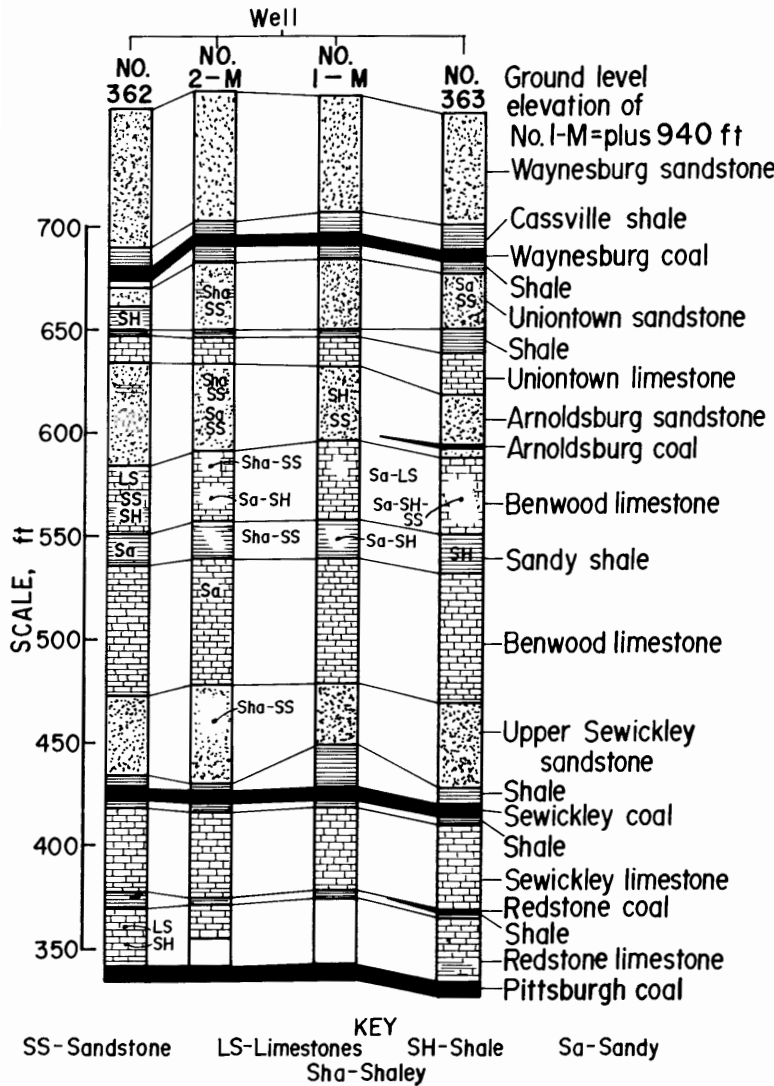

FIGURE 3. - North-south cross section of overburden through Blacksville wells 1-M and 2-M.

Finally, a 7-in liner was run in the well and hung from the casing head. The lower 353 ft of the liner contained a profusion of 1/4-in-wide by 4-in-long slots to permit gas to enter the pipe. The upper 218 ft was left blank and will serve as a guide for test equipment run in and out of the hole.

A second hole (No. 2-M) was drilled by Consol

⁴Reference to specific brands is made for identification only and does not imply endorsement by the Bureau of Mines.

1,330 ft down the panel from No. 1-M. It was completed in much the same manner but without cores, drill stem tests, or tracer bullets. It is to serve as a regular degasification hole, but would, in the process, provide important data for the research work.

RESULTS

Data from logs of No. 1-M and No. 2-M and from two nearby diamond core holes drilled earlier by Consol were used to construct the cross section shown in figure 3. This includes the zones from the Waynesburg sandstone to the Pittsburgh coal. All of this section from the base of the Waynesburg sandstone down is open to the well bore in the test holes.

The drill stem tests run during drilling showed very little evidence of gas in the overburden. A methane detector installed on the rig's air exhaust line did pick up small indications near the top of the Benwood limestone and again in the Sewickley sandstone and coal seam (fig. 4).

Eight monitoring stations were set up underground to measure methane off the longwall gob. These are shown in figure 5. Nearly all the methane off the gob exits through the main bleeder at Station 7. The data for the underground bleeders are compared with those from the surface hole in figure 6.

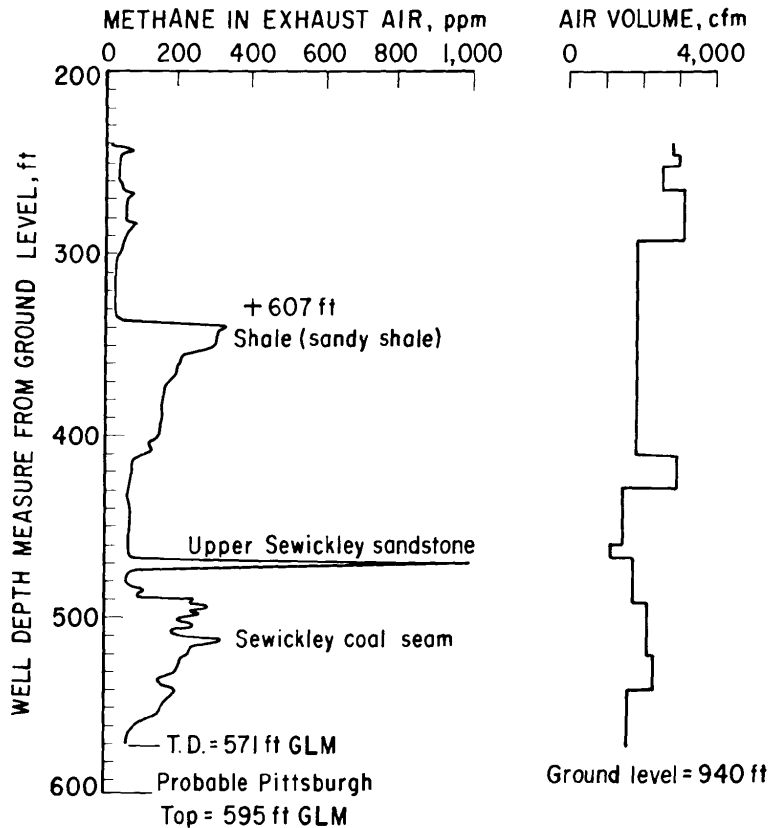

FIGURE 4. - Methane detector data, well No. 1-M.

The longwall passed under the hole on May 1, 1972, and gas production started almost immediately. It peaked at 300 scfm, declined very rapidly, and the hole started intaking air. Pressure returned at the wellhead after a brief shut-in, and gas production resumed as shown in figure 6.

There are numerous similarities between degas hole performance and the gas in the underground bleeders. Both appeared responsive to the rate of mining. For instance, the rate of mining increased significantly on June 7, and this is reflected by an immediate increase in gas both at the surface and in the bleeders.

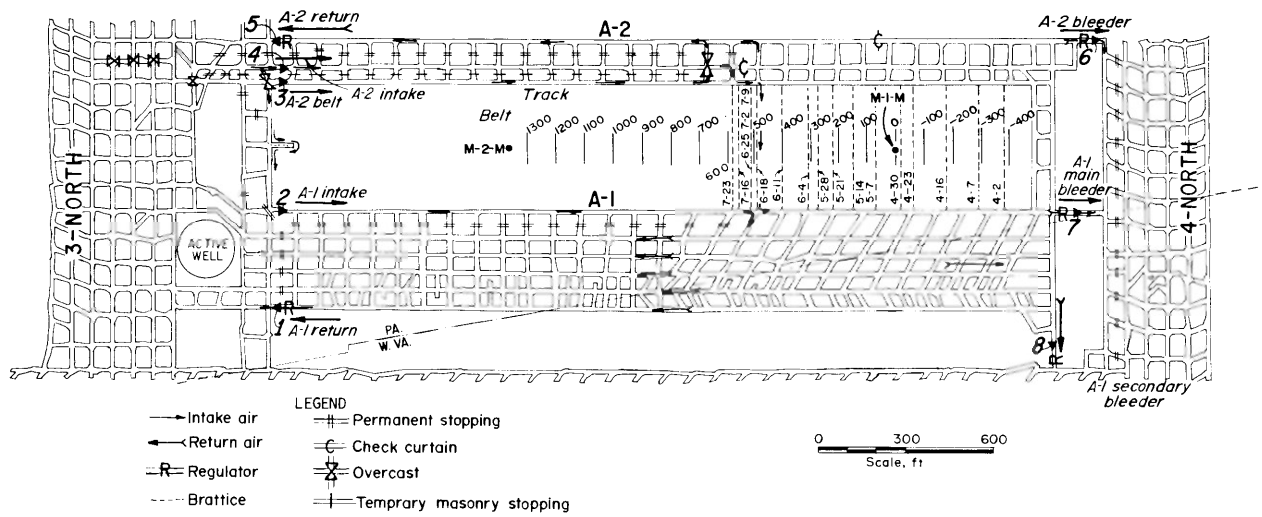

FIGURE 5. - Longwall panel and test stations.

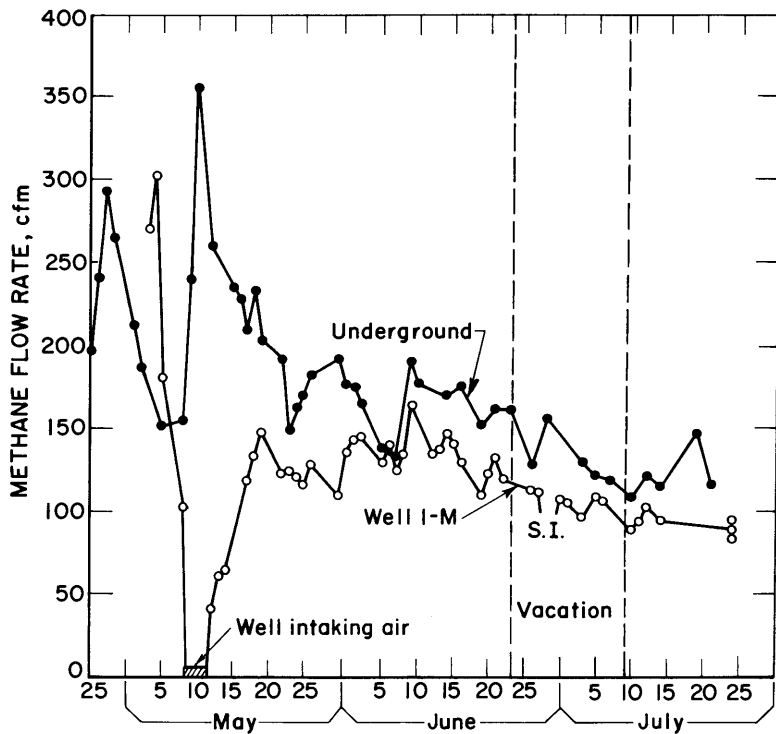

FIGURE 6. - Plot of all methane off the longwall panel underground of the gas production from test hole No. 1-M.

An attempt was made to study the interaction between hole and bleeders during the miners' vacation when No. 1-M was shut in for 2 days (June 28 and 29). The vacation had started on June 23, and gas dropped immediately in the bleeders. The effect of shutting in the well was an immediate bleeder gas increase of at least 30 percent. This dropped back when the well was reopened.

The quantity of methane in both the bleeders and the well increased as work resumed following the vacation. Everything was shut in when the mine was sealed July 24 following a mine fire. The area drained by the hole is still sealed, but No. 1-M is producing again. It currently averages about 60 scfm. It is still producing by

free-flow, as it has throughout its life.

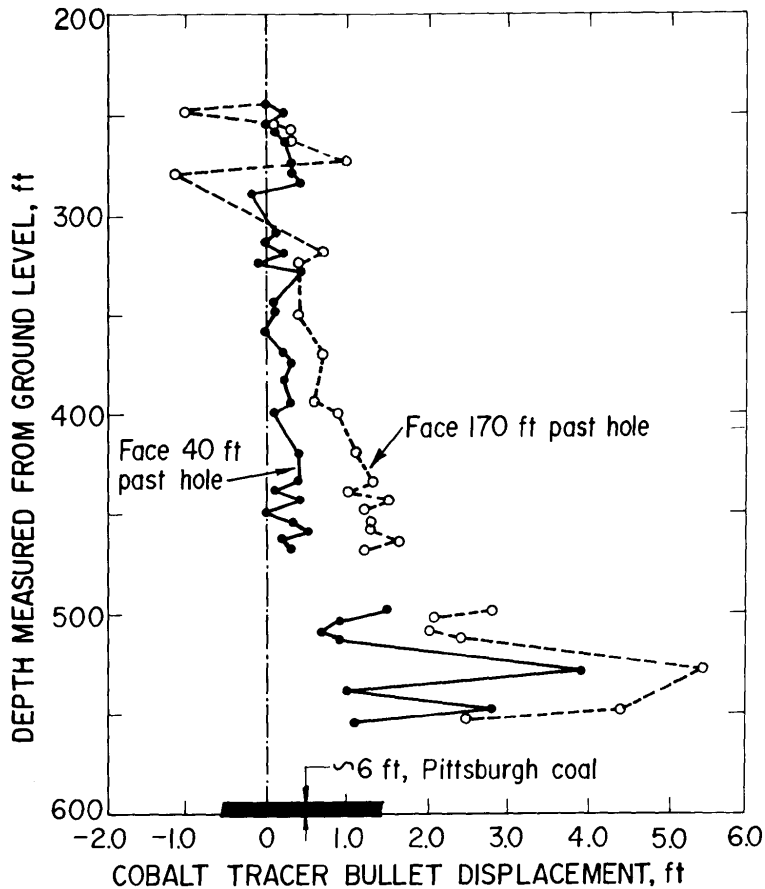

FIGURE 7. - Underground subsidence studies using cobalt tracer bullets.

unit used at that time was less accurate; this could account for some of the variations seen in figure 7. There definitely seems to be a trend, however, suggesting additional movement up to a depth of about 400 ft. This is about 200 ft above the coal. Other logs have been run since. We do not see any further break upward, but there is evidence that the portion from the Sewickley down is recompacting.

Movement of the ground surface along the centerline of the panel was very pronounced as is shown in figure 8. This survey was made when the longwall was about 200 ft past No. 1-M. The wellhead had sunk nearly 6 in at that time, and the maximum surface subsidence appears to have approached 2 ft.

The locations where gas entered the borehole were detected by means of a flow logging device designed and built especially for these tests. Other more "conventional" methods had been considered and one was tried, but none was applicable. These included temperature surveys, mechanical spinners, and a type of hot wire anemometer. The latter was the one actually tested.

Underground subsidence was followed by monitoring the positions of the radioactive bullets with a gamma sonde. Results of the first two such surveys are shown in figure 7. Movement of the bullets are plotted in terms of their apparent displacement from the original position. The latter is denoted by the solid vertical line. The first survey was run when the longwall was about 40 ft past the hole. There appears to be no significant break until a depth of about 480 ft, which is about 30 ft above the Sewickley coal. At that time, two bullets were missing, and there was considerable displacement of the rest. The initial break appeared to have reached about 110 ft above the coal seam.

The second log was run a short time later when the longwall was about 170 ft past the hole. The logging

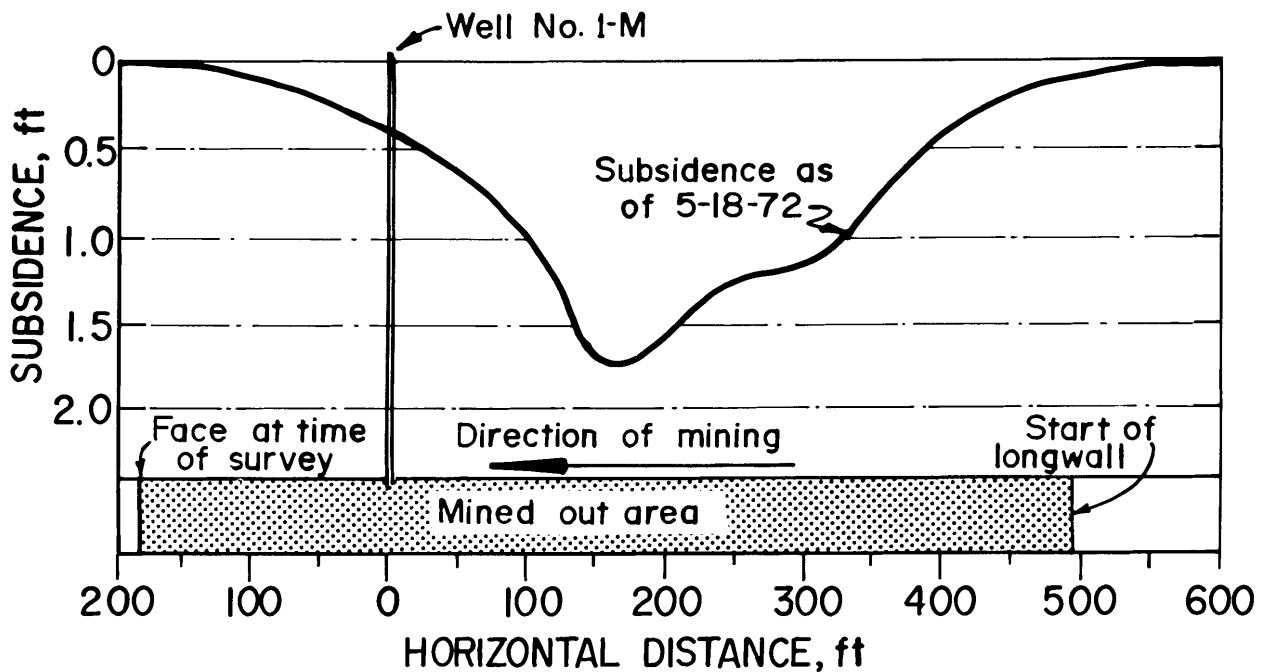

FIGURE 8. - Ground surface subsidence along the centerline of the longwall panel as of May 18, 1972.

The flow logging device used here is shown schematically in figure 9. It is run into the hole in two sections on an electric conductor cable. The lower section consists of a storage reservoir of radioactive krypton gas in nitrogen and a means of releasing small pulses of this gas on command from the surface. The second section is a gamma sonde located about 20 ft above the krypton emission unit. Release of the gas pulse is noted by a surface recorder that has a high-speed paper feed. The gas is carried up the hole past the gamma sonde by the upward flow of methane in the pipe. Passage across the sonde is also noted on the chart. The resulting transit time interval can be converted to a flow rate if it is assumed that the majority of the flow is confined to the inside of the slotted liner.

Runs can be made at different levels in the hole and the results used to plot the percent of total flow at the various levels. Two such runs are shown in figure 10. Only about 20 percent of the gas appears to enter the hole below the Sewickley coal. About 90 percent appears to enter in the first 200 ft above the coal. This corresponds to the zone of subsidence detected by the movement of the radioactive bullets.

Several modifications have been made in the logging equipment since this first work was done. These include the installation of a collar locator in the gamma tool to improve downhole accuracy on the bullet surveys; purchase of a slip ring for the hoist so that continuous gamma logs can be run; and the use of a powered hoist so that deeper holes can be surveyed.

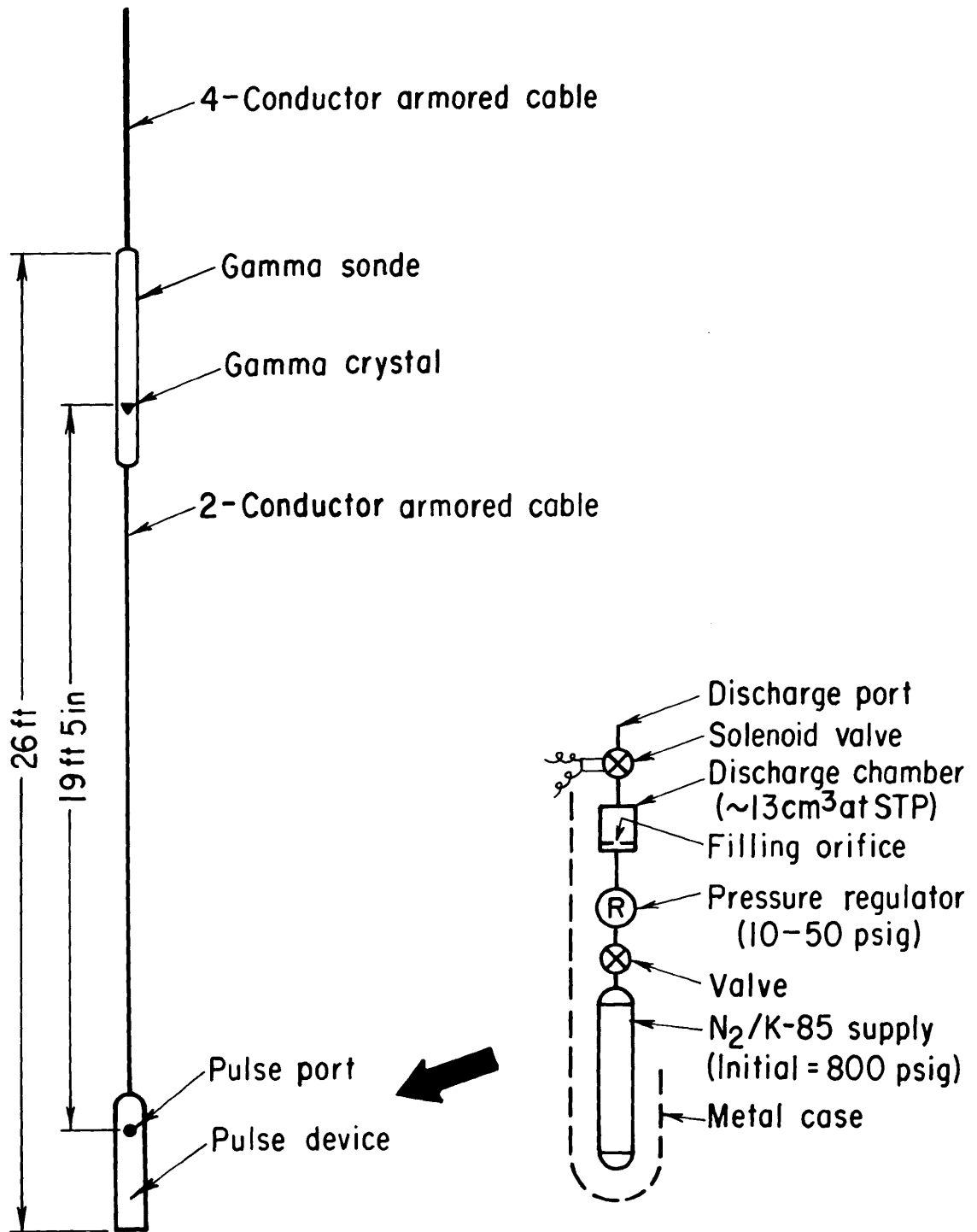

FIGURE 9. - Pulse type flow logger developed for methane.

DEGASIFICATION THROUGH VERTICAL BOREHOLES

by

M. Deul¹ and C. H. Elder²

ABSTRACT

Experimental work is being conducted on degasification of coalbeds in advance of mining in major coal-producing areas in the United States in cooperation with coal mining companies. Work is being done in eight different coalbeds in eight States on properties mined by 10 different companies. Only one site yielded too low a gas flow to warrant further work. All other test patterns are being monitored for gas and water production. We know that water in coalbeds, universally present in our test sites, reduces the permeability of the coalbeds to gas flow and substantially impedes gas flow. The key to degasification is dewatering, so well stimulation methods are being tested to increase water flow rates so that gas flow can be increased. Such stimulation also will increase the drainage radius of the wells.

Progress to date is summarized and production trends analyzed.

INTRODUCTION

The degasification of coalbeds from the surface in advance of mining has long been the goal of researchers in mine safety. Various efforts have been made to successfully accomplish this and the best recorded early efforts are those of Spindler (3),³ Spindler and Poundstone (4), and Merritts, Poundstone, and Light (2). To date no technique for degasification of coalbeds from the surface far in advance of mining has been found economically acceptable.

Attempts were made by the Bureau of Mines to utilize exploration core drilled holes placed by coal mining companies for formation testing in the Pittsburgh coalbed but these were unsuccessful because of the small diameter casing (only 2 in) and the limited size of stimulation equipment that could be used. This work started about 1965, was enlarged in scope somewhat to permit

¹Supervisory geologist.

²Geologist.

Both authors are with the Pittsburgh Mining and Safety Research Center, Bureau of Mines, U.S. Department of the Interior, Pittsburgh, Pa.

³Underlined numbers in parentheses refer to items in the list of references at the end of this chapter.

4-in casing to be placed in an exploratory hole in the Pocahontas No. 3 coalbed in Buchanan County. The experience gained from these holes, essentially negative information, has been summarized in a report by Cervik and Elder (1).

Much of the recorded experience with these attempts at degasification through vertical boreholes was apparently contradictory. Very high gas pressures measured in borehole shut-in tests yielded low gas flow rates, on the order of 1,000 cfd for the Pocahontas No. 3 coalbed whereas shut-in pressures of only 28 psi were measured in the Pittsburgh coalbed in a well that yielded a flow of 24,000 cfd (4).

There was much hearsay on profuse flows of gas from vertical holes drilled into coal-bearing strata during exploration. Tales of drill strings of tools forced out of drill holes and of violent outflows of gas are common. Our direct experience with 53 holes, in that none of these holes exhibited such behavior, is that this would be a very rare occurrence.

Large gas flows have been encountered in drilling holes in fractured rock over subsided strata where longwall mining is conducted. Very high rates of methane emission, on the order of several million cubic feet per day, have been measured in such boreholes that could not be completed to the gob areas. But in this instance we know that the gas was emitted from sandstone horizons that had yielded flows of gas on the order of 40,000 cfd in the unfractured state; after subsidence these strata were fractured and the initial flow rates were increased manyfold. All of these experiences and the observations made in the conduct of our other research on methane control reviewed by Zabetakis, Deul, and Skow (6) logically led us to conclude that certain physical factors must be considered in conducting further experiments on degasification through vertical boreholes.

PHYSICAL FACTORS

The physical factors we consider important have, at first thought, been relatively obscure. They are:

(1) Coal, unlike most other gas-producing formations, has a low porosity, especially in contrast with sandstone which has a large interstitial porosity.

(2) The permeability of coalbeds may be directional--some coalbeds exhibit much greater along the face cleat than along the butt cleat.

(3) Most coalbeds are water saturated and, as a consequence, exhibit a low gas permeability.

(4) Coal, because it has a low mechanical strength, readily suffers formation damage; this in turn may substantially reduce the permeability at the periphery of the holes drilled into coalbeds.

(5) Coalbeds do not exhibit uniform physical and chemical properties.

These factors must be understood before any large-scale efforts at degasification of coalbeds can be successfully undertaken. Currently, the Bureau is completing a comprehensive program to test candidate coalbeds and to produce gas from these coalbeds along projected development areas of existing and newly developing mines in these coalbeds.

DEGASIFICATION TEST SITES

Several important criteria were applied in selecting sites for experimental vertical degasification holes. These were:

- (1) Known or suspected high methane content in coalbeds.
- (2) Large block of unmined coal for drilling.
- (3) Planned mining of block within 3 to 5 years of drilling.
- (4) Favorable geological conditions.
- (5) Cooperative agreement and ready acquisition of right-of-ways for drilling.

Usually all these criteria were met before drilling was started. In one instance mining conditions were such that the mining company has gone out of business so mining projections will not be met on schedule; in another, what had been expected to be a serious situation insofar as gas in horizons immediately above and below the coalbed mined has not yet materialized from the well tests but may yet yield useful data when mining causes relaxation of strata. Data useful to mine planning are expected from all the patterns.

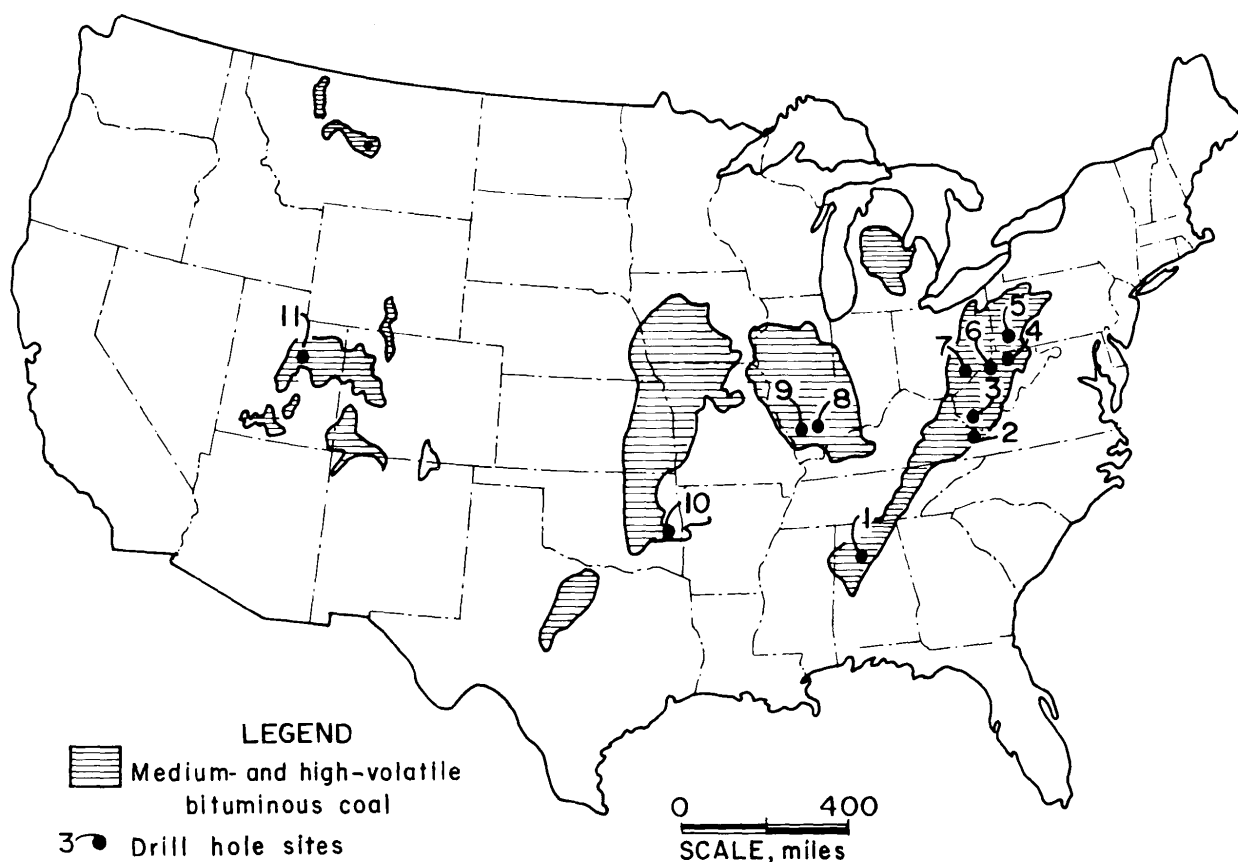

FIGURE 1. - Vertical degasification sites in the bituminous coalfields of the conterminous United States.

The drilling sites selected are shown in figure 1 and are distributed among the major bituminous coalfields of the United States. The Northern Appalachian drill sites are shown in figure 2. Data on all the sites are summarized in table 1. Except for early exploratory work on sites in Buchanan County, Va., and Monongalia County, W. Va., all of the holes have been drilled since May 1971 and were completed as recently as December 1972.



FIGURE 2. - Northern Appalachian degasification sites.

TABLE 1. - Summary data on degasification sites

Coalbed	Seam thickness, ft	County	State	Company	Mine	No. holes	Date drilling started	Date first hole on production	Depth, average ft	Pressure		Gas production to 4/1/73, ft ³
										DST ¹	WL ²	
Pittsburgh	6	Washington	Pa....	J & L.....	Vesta No. 5.	5	9/71	6/72	430	-	166	1,900,000
Do.....	6-7	Marion....	W. Va.	Consol.....	Loveridge	5	11/71	10/72	850	167	-	1,400,000
Do.....	6	Monongalia	W. Va.	Eastern.....	Federal No. 2.	5	8/70	3/73	800	276	-	27,000
Pocahontas No. 3.	4	Buchanan..	Va....	Island Creek	Va. Pocahontas.	3	4/67, 4/70	6/72	1,500	580	670	780,000
Do.....	4	...do.....	Va....	Consol.....	-	2	8/71	None	-	-	-	-
Do.....	4	Wyoming...	W. Va.	...do.....	Kepler...	5	7/71	3/72	762	158	155	644,000
Mary Lee..	5	Jefferson.	Ala...	U.S. Steel..	Oak Grove	5	5/71	2/72	1,076	-	399	1,545,000
Hartshorne	3	LaFlore...	Okla..	Howe.....	Howe.....	5	10/71	1/72	584	-	253	786,000
Illinois No. 6.	8-9	Jefferson.	Ill...	Inland Steel	Inland...	5	6/72	3/73	733	122	122	-
Illinois No. 5.	4	...do.....	Ill....	...do.....	-	5	7/72	-	783	21	-	-
Clarion 4A.	5-6	Meigs.....	Ohio..	Ohio Power..	Wellston.	3	6/72	None	380	55	-	-
Subseam...	3	Carbon.....	Utah..	Carbon Fuel.	Carbon...	4	10/72	1/73	1,016	347	-	6,000

¹DST--Drill stem test pressure measurement.

²WL--Water level pressure.

RESULTS TO DATE

Water and gas are being produced from most of the patterns drilled. One hole in each pattern is generally not put in production but is used as a monitoring hole to measure gas pressures and to determine the extent of interference from production of the other holes in the pattern.

All of the holes on production yield water and gas. Water in the fractures and macropores of a coalbed reduces the flow rate of gas from the coalbed. Consequently, all the drill holes are outfitted with pumps to remove the water intermittently. Generally, as the water is pumped from the formation the flow rate of methane increases.

Gas pressures are determined either by standard drill stem tests or by measurement of the height of the water level as gas flow is arrested by the equalized pressure of the water column in the casing. Where permeability is very low and the gas flow rate is so low that the normal time allotted to the drill stem test for bottom hole pressure is inadequate, no successful measurement is possible using standard drill stem test procedures. All the producing patterns are now being fitted with a bottom hole device to measure pressures at will; these data will soon be acquired.

Dewatering is of utmost importance. As water flow rates decline, all other factors being equal, the gas flow rates increase from a vertical borehole in a coalbed. Figure 3 is a plot of the water flow and gas flow rates versus time for a single hole in the Alabama pattern.

COMPOSITION OF COALBED GASES

Gas samples taken from vertical boreholes have variable compositions depending upon location. Table 2 lists typical analysis from the Pittsburgh, Pocahontas, and Mary Lee coalbeds.

TABLE 2. - Composition of gas from vertical degasification holes

Coalbed	CH ₄	O ₂	N ₂	CO ₂
Pittsburgh:				
Washington County, Pa.....	98.0	0.0	1.0	0.7
Marion County, W. Va.....	92.1, 92.4	0.3, 0.2	1.0, 0.7	6.5, 6.6
Monongalia County, W. Va.....	90.7, 90.8	0.3, 0.3	1.1, 1.1	7.3, 7.2
Pocahontas No. 3:				
Buchanan County, Va.....	97.9, 97.6	0.2, 0.1	1.0, 0.8	0.78, 0.4
Wyoming County, W. Va.....	97.6, 99.1	0.6, 0.2	1.8, 0.7	0, 0
Mary Lee: Jefferson County, Ala...	96.0	0.1	3.5	0.1

These analyses will be compared with those from samples collected at varying intervals to determine the nature of the compositional changes with time as desorption proceeds.

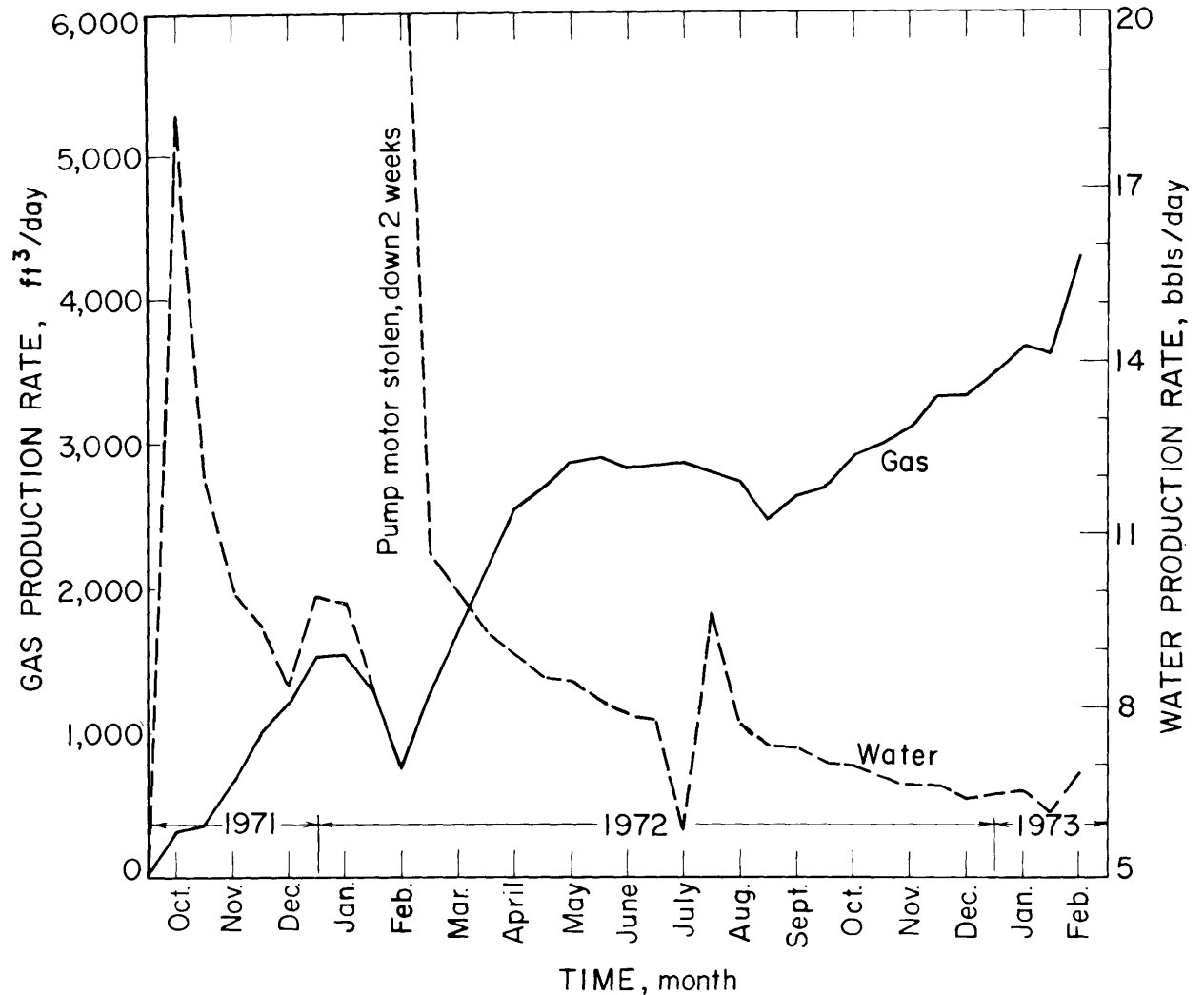

FIGURE 3. - Gas and water production, No. 3 SW hole, Oak Grove mine, Alabama.

DISCUSSION

The relatively low gas flow rates from the vertical degasification boreholes as compared with those from early degasification experiments can be readily explained by the fact that the blocks of coal in which these tests are being conducted are remote from active mining areas and have not yet been dewatered. Research being conducted at the University of Pittsburgh under a grant agreement shows that "the effective permeability to gas increases most rapidly with decreasing water saturation over the higher water saturation range" (5). This means that low gas flow rates are to be expected until the coalbed is dewatered around the vertical borehole.

Knowing that coalbeds are water-saturated, we can now proceed to hydrofracture selected sites to increase the permeability of the coalbeds and the flow rate of methane gas, and to substantially extend the drainage radius of

each borehole. Water removal is the key to degasification. Simple free drainage will not succeed because the water column forced into boreholes by gas pressure will eventually equalize the reservoir pressure and shut the wells in.

The scientific program of analysis of coalbeds as gas producing reservoirs that will result from this study will ultimately provide realistic criteria for evaluation of degasification of coalbeds. These studies, coupled with the results of studies such as those reported by Fields in this seminar, and novel methods of drilling long holes in coalbeds parallel to the bedding will yield means of demonstrating the feasibility of degasifying coalbeds which exhibit moderate and high gas permeability. Coalbeds which exhibit low permeability will require further research.

REFERENCES

1. Cervik, Joseph, and C. H. Elder. Removing Methane From Coalbeds in Advance of Mining by Surface Vertical Boreholes. Proc. Conf. on the Underground Environment, Univ. Mo.--Rolla, Oct. 27-29, 1971, pp. 209-228.
2. Merritts, W. M., W. N. Poundstone, and B. A. Light. Removing Methane (Degasification) From the Pittsburgh Coalbed in Northern West Virginia. BuMines RI 5977, 1962, 39 pp.
3. Spindler, G. R. Degasification of Coal Seams. Coal Mine Modernization, 1953, Am. Min. Cong., pp. 206-220.
4. Spindler, G. R., and W. N. Poundstone. Experimental Worth in the Degasification of the Pittsburgh Coal Seam by Horizontal and Vertical Drilling. Trans. ACME, v. 220, 1961, pp. 37-46.
5. Taber, J. J., P. F. Fulton, and A. A. Reznik. Development of Techniques and the Measurement of Relative Permeability and Capillary Pressure Relationships in Coal Grant Agreement No. G-0122006. Quart. Tech. Rept., Sept. 1-Oct. 31, 1972, 12 pp.
6. Zabetakis, M. G., Maurice Deul, and M. L. Skow. Methane Control in United States Coal Mines--1972. BuMines IC 8600, 1973, 23 pp.

PANEL DISCUSSION

Panelists:

John Ashcraft, West Virginia Department of Mines, Charleston, W. Va.
Robert Dalzell, U.S. Bureau of Mines, Pittsburgh, Pa.
James Davis, Continental Oil Co., Morgantown, W. Va.
Peter Ferguson, Bethlehem Mines Corp., Johnstown, Pa.
William Laird, Eastern Associated Coal Corp., Pittsburgh, Pa.
James Micheal, U.S. Bureau of Mines, Morgantown, W. Va.
J. J. Yancik, U.S. Bureau of Mines, Washington, D.C.
M. G. Zabetakis, U.S. Bureau of Mines, Pittsburgh, Pa.; moderator.

Dr. Zabetakis. Before continuing with the panel discussion, I have been asked to give the highlights of the material presented here today. Basically, what we have attempted to show is that there is a lot of gas in our coal, and that as mining rates and depths increase, the gas emission rates will also increase unless we exercise some control over the gas; we are going to have to think seriously about degasification. We have seen instances here today where some mine operators and Bureau of Mines investigators have been successful in liberating up to 80 percent of the gas in a particular area, using fairly conventional techniques. Where gas is still a problem, we now have procedures that are usable in blocking the flow of the gas to the face.

Horizontal and vertical boreholes are quite useful in degasifying virgin coal and gob areas, respectively. In the first case, we have found methane emission rates to be about 0.1 cfm/ft² of surface area from 3-in boreholes. This is about an order magnitude more than the emission rates from exposed ribs. This means, therefore, that if you want to complete a degasification job in a short period of time, you either have to drill long holes or larger diameter holes, or, perhaps, hydrofrac these in order to increase the surface area, provided that the hydrofracing operation will not damage the roof significantly. To reduce gas emission rates to a manageable level, we must plan ahead. Many of the European mines are recovering 50 percent of their gas--even in their very deep mines. We feel this can also be done here.

With this thought, then, let me very briefly introduce our panelists. We have to my right, Mr. John Ashcraft, director of the West Virginia Department of Mines, whom I am sure you all know; to his right is Mr. Robert Dalzell, chief of the Bureau's Ventilation group, Technical Support Center in Pittsburgh; to his right is Dr. Joe Yancik, who spoke to us earlier and, I am sure, needs no further introduction. To my left we have Mr. James Micheal, district manager, District No. 3, Health and Safety--all those of you in this area know Jim quite well. To his left is Mr. James Davis who talked to us earlier; to his left is Mr. Pete Ferguson, who also spoke to us earlier; and to his left is Mr. Bill Laird, vice president--engineering, Eastern Associated Coal Corp., who has been extremely helpful to us in the conduct of our work in the Federal No. 2 mine.

Before we proceed with questions from the floor, let us hear from our panelists. First, Bob Dalzell.

Mr. Dalzell. Good afternoon, gentlemen. It has been a pleasure to sit in on the meetings with you today. I am sure that it has been an education to me. It has been a revelation to learn of some of the techniques that have become available for use in control of methane in underground mines. Gentlemen, methane and methane control has been a problem in underground coal mines since the inception of mining in the United States. The classic method of control of methane in underground mines has been by the controlled movement of air to the underground passageways and the use of adequate quantities to dilute, render harmless, and carry away the methane that was introduced into the mine environment.

Unfortunately, every ventilation system, regardless of whether it is the one that includes the entire mine or the face ventilation system that is employed from the last open crosscut to the working face, has a capacity. If we exceed the methane dilution capacity of the system, then we have a problem. Hazards increase and the probability of ignition becomes more predominant. It is not at all uncommon to have in some of the gassy coal mines, methane concentrations of 0.2 to 0.3 percent on the intake airstream; in some cases, even higher percentages of methane are found. Now if we are talking in terms of a quantity of air being used to ventilate a working place, say, 10,000 cfm, then this means that the total volume of air that has been delivered to that point has a capacity for dilution of 100 ft³ of methane. If our intake air is contaminated by 0.2 or 0.3 percent methane, then we have reduced the capacity of our system for dilution of methane in the immediate face area by 30 percent before we start mining coal.

Today we have heard a number of techniques described which give clear indications that tools may be available whereby we can control the influx of methane from rib liberation and, possibly, from liberation at the immediate face area. Gentlemen, if we could reduce, in my hypothetical example, the concentration of methane in our intake airstream, it would increase the capacity of our system at the face by 10 percent with a simple reduction of 0.1 percent in the intake air courses. I believe that the ventilation system must be made the primary technique for control of methane underground. However, papers that have been presented today and the state-of-the-art indicates that additional very strong tools are available whereby we can, perhaps, reduce the amount of methane introduced into our coal mines, and thereby decrease the hazards to the miners who are working in our mines and, also, reduce the cost of ventilation as we go into deeper coal seams with anticipated higher methane concentrations.

Dr. Zabetakis. Next, we will hear from Mr. John Ashcraft.

Mr. Ashcraft. Gentlemen, as the director of the Department of Mines of the Nation's leading coal producing State, I am very happy to have the opportunity to attend your seminar. I must admit, however, that appearing as a panelist is not one of my favorite pastimes.

Since safety in our coal mines is a prime objective of our department, we are vitally interested in any innovation or technology that might be geared toward that goal. Since methane does constitute a constant hazard to the

mining industry, we are extremely interested in the degasification programs carried on in our various mines. I was invited and attended the initial meeting at the Federal No. 2 mine and given an opportunity to express my ideas, both pro and con, on the subject.

Our department has participated in an active manner since that program started and I am kept abreast of the program as it progresses. I feel certain, as we get further into degasification of mines, that more and greater problems will arise and I am sure that each one present here today will, by necessity, become deeper involved. The persons that presented the papers should be highly commended for the job that they have done. Their papers were well prepared, very well presented, and to me, very educational. Thank you.

Dr. Zabetakis. Our next panelist needs no further introduction; however, let me say that I have had a number of inquiries over the past 2 years regarding our use of special equipment underground. The man who inspects this equipment and keeps us on the straight and narrow in this area is Jim Micheal and the other members of District 3.

Mr. Micheal. Thank you. I think the persons that are responsible for this program today, particularly those who participated on the program, are to be commended for a splendid job. In Health and Safety, of course, our primary responsibility is enforcement and administering the Federal Coal Mine Health and Safety Act of 1969. This also includes, as Dr. Zabetakis stated, serving as a kind of watchdog over the research programs that are conducted underground and on the surface at our coal mines. This responsibility includes, in cooperation with the research, technical support, the approval of the kinds of equipment, the inspection of the equipment, the approval and subsequent inspection of such installations, and approval of work procedures that are used underground. In the past we have cooperated fully with the operating people in the mine, with the miners themselves, and with the State department of mines; in all cases, our goals in these programs are the same, only our ideas as to how to attain these goals sometimes differ. But so far we have been successful, and, knowing the history of the mines, particularly in the northern part of West Virginia, we can appreciate the need for a degasification program. We will continue to support the program and do everything in our power and within our authority to see that this program is carried on. Thank you.

Dr. Zabetakis. Jim Davis, again, needs no introduction, so I will merely pass the microphone on to him.

Mr. Davis. I have been given a choice on what to talk about. However, I want to stay on the technical side and make a couple of comments on one subject that has come up several times--that is, hydraulic fracture.

I do not know how well acquainted everyone is in the room with this technique. It was developed about 20 years ago in the oil industry, and it followed years of using acids and nitro shooting to try to stimulate production from oil wells and it thoroughly turned the oil industry inside out. It is one of the finest things that has ever been developed for stimulating flow

from oil and gas wells. But it does have some limitations. I would like to comment on a couple of them before some people get into trouble.

One is, that you have got to have good well completions if you are to contain the breakdown pressures. By this I mean that the technique that works extremely well on some of the degas holes that are cemented on the outside of the pipe is likely not to work in other cases. You must control the fractures. You do not want to break up on the outside of the pipe and get into roof zones or some other area of the mine.

The other point is that hydraulic fractures want to follow the easiest path. One of the things that both helps us and plagues us in the Pittsburgh seam is the highly directional nature of the permeability. Joe Cervik quoted a 10 to 1 figure this morning as the ratio of the permeability along the face and butt cleavage planes. However we start the fracture, it probably will follow the face cleavage because this is an easy path. What we will do is to increase the permeability in the very direction along which we have already got a high permeability. I am not sure of Maury Deul's fracturing plans, but I am sure he will have taken these factors into account, and we will see some attempts at frac jobs in which he will try to cut across the face cleavage somehow to open up the coal. Thank you.

Dr. Zabetakis. Mr. Pete Ferguson, our next panelist, indicated that he did not have too much to add to his talk. However, is there anything else that you would like to say at this time?

Mr. Ferguson. Well, perhaps I can expand on the talk. Our problem is unique in that we can mine within the seam and not really be hampered too much by methane liberation from the coal. We are fortunate in this respect and also that our large concentrations of methane are in our roof strata up at least 30 ft; this gas is retained there by an impervious clay bed under the C prime seam. So in our thinking we have confined our thoughts to this area in the upper strata. We are now satisfied that vertical boreholes are doing a good job for us and we will continue to try to take more of the methane out of our boreholes. For the future, we may try to confine this methane in our long-wall blocks by actually constructing stoppings in the crosscuts after we have completed our mining. This we are doing in conjunction with the Bureau and some of their research teams. We feel that the more we can take out through our boreholes, the more efficient and more safely we can mine underground. The only thing is that if there are questions, I would entertain them.

Dr. Zabetakis. We are going to come back to the questions shortly. With that in mind, if there are any questions, let us hold them for just a few more minutes. Now we will hear from Mr. Bill Laird.

Mr. Laird. I thank you for the opportunity to be here today. It gave me an opportunity to find out what others are doing in the area of degasification. As you know, Federal 2 is located in Monongalia County near Bula, W. Va., on Miracle Run. This mine produces between 8 and 11 million ft³ of gas in 24 hours. We have worked closely with the Bureau of Mines in attacking the problem of degasification. We hope to provide a safe and healthy environment for our coal miners, to increase productivity, and conserve our natural resources.

Under a cooperative agreement with the U.S. Bureau of Mines, we have drilled a 1,030-ft, 24-in-diameter hole in the 2 North mains. This is the area that Steve Krickovic noted released 33.7 ft³ of gas per ton of coal mined; the entry development in this area was halted because of high gas liberation. I might add that the 24-in-diameter hole can also serve as an escapeway in the event of an emergency. Our plan is to lay 8-in pipe from the borehole into the gassy area. This is phase I of a larger program. The work will be done in stages to determine if what we are doing is successful; if it is, this will encourage us to go on to set up a degasification system for the entire coal mine. We are now in the process of setting up the ventilation system, and putting power back into the section so that we can cut through to the borehole pipe which will be fitted with an escape hatch similar to that in a submarine, so that it can be opened quickly by turning a big wheel and dropping the lid.

A pipeline will be laid along two entries to permit us to drill holes 1,000 to 2,000 ft long about 5 degrees off the centerline; this will open up a large area and will permit the gas to flow to these holes. The multipurpose borehole will serve as a guide in this work. As you heard earlier, Herb Fields noted that he is draining about 150 ft³ of gas per day per foot of borehole. So if we go to a depth of 1,000 ft, we should have something like 150,000 ft³ of gas per day to contend with. In reviewing this problem with Mr. Micheal, we were reminded that we must keep the gas out of the present returns. So we must set up a negative pressure system to drain the gas while we drill. This will involve drilling through a stuffing box which is connected to a compressor on the surface. If the gas is of sufficient quality, we will try to get it to a gas distribution system. However, the main purpose of this study is the degasification of the mine ahead of mining.

To start this program, we first had a meeting at the mine office and invited the safety committee, the president of the local district UMW, Mr. Micheal, and others from the Research and Technical Support groups of the U.S. Bureau of Mines. We have discussed all aspects of this work; the safety committee is well informed, and it is our intention to keep them abreast and to make them a part of this program. If we are successful in the first phase, then we will proceed to the second phase, which is to extend the pipeline to other parts of the mine. In particular, one area is sealed at the present time; it contains gas. We hope to tap this gas and send it into our pipeline.

It might be advisable to put down other borehole shafts instead of laying more pipeline. But at the present time, we are planning on laying pipe as we drill additional holes. We do not know exactly how long we will be able to produce gas, so we are only considering the first phase at present. If there are any questions, I would be more than glad to answer them at this time. Thank you very much.

Mr. Krickovic. Bill, how far have the West mains been driven?

Mr. Laird. The progress of West mains is slow because they are in virgin area, and are advancing with five or six entries. They have advanced about 700 ft and have about 5,700 ft to go.

Question. What do you plan to do with this gas?

Mr. Laird. I was in Germany about 2 years ago and found that their gas was piped back to the shaft and brought to the surface where it was used in their boilers and bathhouse. Perhaps we can do the same thing initially.

Question. What does Bethlehem do with their gas?

Mr. Ferguson. We are still involved in trying to determine who owns it.

Question. Are you venting it right now?

Mr. Ferguson. Yes, we are presently venting it to the atmosphere.

Dr. Zabetakis. Are there any other questions? These may be directed to any of the panelists or to the speakers.

Question. Mr. Davis, will you enlighten us a little bit on what you people have done in research as far as quality control is concerned.

Mr. Davis. What do you mean?

Question. Well, I know that you have been doing some research on what has to be done to the quality of methane involved in degasification. I am quite sure that a lot of people here do not realize that it (methane) is not considered a marketable product as it comes out of the mine. And there are some problems of getting the methane to a marketable state before it goes into a pipeline system.

Mr. Davis. I am going to disappoint you because we have not really looked at this problem very much. We have found that the gas from our gob drainage wells is not typically an oilfield type gas. It is very very lean; it is comprised, as far as hydrocarbons are concerned, usually only of methane, with a slight trace of ethane; seldom do we see propanes, butanes, and pentanes. So we end up with a product that at the very best, if it were pure hydrocarbon gas, would be about 1,000-Btu gas where typically oilfield gases will run somewhere from maybe 1,050 to 1,150 Btu's (per cubic foot). Also, the gas may contain 1 or 2 percent carbon dioxide. We feel that if we eliminate the air we can get a salable product.

While I have done very little work on the composition of these gases, I do think I have seen a trend; as we get farther to the west toward Blacksville, and Federal No. 2, there is a higher carbon dioxide content--perhaps 8 to 10 percent rather than 1 or 2 percent. So I think that we must either enrich the gas with propane or go the other way and scrub out the CO₂ since propane is scarce.

In the last hole that we have completed, we have also found a small amount of H₂S. This may be easier to get rid of than the CO₂. I know H₂S can be scrubbed out too, but whether it is economical at present, I do not know.

Question. Have you ever considered using this gas for your own purposes at the mine?

Mr. Davis. We have used it; but when we first started toying with the idea of trying to put it into somebody's pipeline we thought that we could make a trade with the company selling us gas in the area. Actually, one of our degasification holes produces in a week or two, more gas than we use in a year. So this use is only a drop in the bucket compared with the amount of gas that can be produced.

Dr. Zabetakis. In connection with this question, we have issued a request for a proposal to study the economic feasibility of recovering and utilizing this gas. Hopefully in about a year, we should have some answers to such questions in terms of gas production rates and mine location.

Question. Has anybody determined the legality of who owns this gas yet?

Dr. Zabetakis. This is one of the items that is to be studied.

Question. All of our discussion has been on single seam mining, what will you do in a multiple seam mine where anticipated gas is in more than one seam and you plan to mine the upper seam first? What could you do toward degasifying that seam and the lower seam prior to any mining and use? Would the hole itself possibly cause problems with gas in the lower seam while degasifying in the upper level?

Dr. Zabetakis. The question has to do with multiple seam mining which is encountered in European mines to a greater extent than it is here, although as time goes on, of course, it will be encountered here too. Does anyone care to comment on this?

Mr. Deul. We just had a little bit of experience with this and the picture is not very clear. For example, Pete Ferguson was telling you about the mining in the Lower Kittanning coalbed where there is not much gas, although there is gas in the Upper Kittanning with relatively low pressure. We have a similar situation in the Illinois No. 6 as related to the Illinois No. 5 coalbed where our preliminary measurements show that the Illinois No. 6 coalbed is relatively higher in gas content than the Illinois No. 5 which is not very far below it. The picture as I see it right now is that we cannot answer this question very simply because of the problem of migration of gas during the early stages of coalification, because gas is produced not only from the coal but also from the carbonaceous matter in the adjacent strata. And as these are compacted, the whole sequence of coalbeds and intermediate strata may have to be considered as a unit; therefore, we are going to have to do more work to determine what this interrelationship is. Now, certainly, where there are coalbeds widely separated by a thick sequence of rocks then each coalbed or, perhaps, each sequence of coalbeds becomes a separate problem. But this is much too early to answer these questions right now.

Question. Has there been any work done on this water infusion from the surface or has it all been inside horizontal holes?

Mr. Cervik. We have never attempted any water infusion of coalbeds using vertical boreholes. It has all been underground water infusion.

Question. Sir, could you give us some information on the equipment required, drilling equipment for water infusion and type of drill power, and so forth?

Mr. Cervik. Generally when we do a water infusion job we prefer to use an air drill because it is lightweight and can be moved and set up very quickly; we use a hand-held air drill that consumes about 200 cfm of air at 100 psi. We use a drag bit and EX casing; there is nothing critical about the casing. There is no reason why, perhaps, you could not use an auger as long as you are drilling the hole with water.

Question. What size average diameter hole do you drill for water infusion?

Mr. Cervik. For water infusion we standardize on a 3-in-diameter hole mainly because our packers are 3 in. in diameter. Of course, there is no reason why the hole cannot be grouted in.

Question. What maximum depth do you use?

Mr. Cervik. When we use hand-held equipment, we limit our depth to about 125 ft. There is nothing sacred about this distance other than that in some cases, entries are advanced in 100-ft increments. Generally you can advance, say, one break in a week. But if you want to use a 200-ft hole, then you can mine for a much longer period before reinfusing.

Question. Mr. Cervik, what would be the feasibility of infusing a panel of coal once it is isolated to degasify a coal mine?

Mr. Cervik. There is no problem with infusing a panel. However, we infuse panels for dust control, not methane control.

Dr. Kissell. Why would you want to infuse a panel? Most of the gas is trapped in the solid coal and is not in the fractures. When you push water through you push it through the fractures; this forces out only the gas in the fractures which constitutes only 5 to 10 percent of the total. At the same time the infused water would reduce the permeability and block the flow of gas.

Question. That is not my question. Is it feasible to infuse a panel?

Dr. Kissell. Oh yes. Water can be pumped into it.

Dr. Zabetakis. In the experiments described by Mr. Cervik, holes were drilled when a panel was outlined for degasification purposes; water was never put back in the degasification holes except to decrease the dust content. Bob Vinson can give us a little more information on this subject.

Mr. Vinson. No, there was very little noticeable effect of water infusion on methane. But we did find a 40 to 79 percent decrease in dust levels. Infusion was particularly successful in the Pocahontas No. 3 coalbed because it seems the dust is inherent in the coal--it is a very friable coal.

Mr. Krickovic. I would like to emphasize a methane control technique that has not been discussed today, which I think is very significant. And it supplements what Bob Dalzell said in connection with a good ventilation system. I refer to safely accessible bleeders. I think a ventilation system is not adequate and complete without a safely accessible bleeder system. That is, one that would permit an adequate pressure differential to develop across the gob so as to keep the gas movement away from the working face. This, in my opinion, is required regardless of any supplementary degasification methods, such as the vertical borehole. Actually, boreholes may be 300 to 500 ft from the beginning of a pillar line and gas must be bled from the gob even before borehole interception.

Incidentally, based on my many years of experience in ventilation, there are too many open splits. I found as many as three in some cases; this should not be allowed. Every active split in a mine should be regulated to some degree to provide the flexibility that is required to control the volume of air in the different splits as the demand requires.

Dr. Van Dolah. I would like to thank Pete Ferguson and Jim Davis for taking the time to be with us and present their papers. I would also like to thank the other panel members and each of you for coming. We think we have a story to tell; we are happy to have an audience. Again you are welcome to visit us at Bruceston any time. Please come. Thank you.

QUESTIONS SUBMITTED AFTER THE SEMINAR

Question. How was the multipurpose borehole enlarged?

Answer. The borehole was enlarged manually with chipping hammers and pavement breakers after ventilation had been established in the borehole.

Question. What are your thoughts regarding the placement of a 24-in-diameter borehole at the back end of a bleeder panel and utilizing a permissible high pressure fan on the surface to move 12,000 to 15,000 cfm of air/gas mixture and thus maintain a greater pressure differential across pillar workings?

Answer. We feel this is desirable in all cases where a dead end is created.

Question. Why turn mining over to the drillers? Could the (Federal No. 2) project be done with a combination of vertical boreholes and a minimum number of mine entries?

Answer. We would hope that the drilling operations associated with methane control can ultimately be incorporated into the mining cycle; the underground operations would then be handled by the miners.

Question. What about gas rights where a coal company does not own them?

Answer. A. D. Little, Inc., has recently been awarded a contract to determine the economic feasibility of recovering and utilizing methane emitted by coal. As part of this study, the contractor is to consider the legal problems associated with the collection and use of such gas.

Question. Will there be problems associated with the compression of mine gas before pumping it into a transmission line?

Answer. The most critical procedure associated with such an operation is the detection of air in the mixture to be compressed. However, this is not unique to our operations; monitors are available to assure that only suitable gas is compressed.

Question. Is water injection feasible from the surface?

Answer. Yes; however, it would be a rather expensive procedure in deep mines.

Question. Is any work being done to separate mine gas (from air) at the mine fan?

Answer. No. However, we have asked A. D. Little, Inc., to consider the methane in the exhaust air in their study of the economic feasibility of recovering and utilizing methane emitted by coal.

Question. What type of pumps are used in dewatering coal?

Answer. None. The water is forced out by the gas liberated by the coal.

Question. Is water infusion similar to the water drive procedure used in the oil and gas business?

Answer. No. Basically, we are advocating the use of water to block methane rather than drive it from an active face.

REGISTRATION LIST

Seminar on Methane Control in Eastern U.S. Coal Mines
U.S. Bureau of Mines Technology Transfer

May 30-31, 1973

James Adkins Island Creek Coal Co. Holden, W. Va.	Donald D. Born Mountaineer Coal Co. Fairmont, W. Va.
Erman Altizer Youngstown Sheet & Tube Co. Dehue, W. Va.	James E. Bresinger U.S. Bureau of Mines Johnstown, Pa.
John Ashcraft West Virginia Department of Mines Charleston, W. Va.	Walter E. Bullers R & P Coal Co. Indiana, Pa.
Ken Austin Calvert Western Explosives Co. New Concord, Ohio	L. B. Burke Carbon Fuel Co. Charleston, W. Va.
James A. Barlow West Virginia Geological Survey Morgantown, W. Va.	Joseph Cervik U.S. Bureau of Mines Pittsburgh, Pa.
C. O. Bartron Westmoreland Coal Co. Quinwood, W. Va.	William D. Conner Columbia Gas Transmission Corp. St. Albans, W. Va.
D. A. Bayer Bethlehem Mines Corp. Madison, W. Va.	Henry Cook Carbon Fuel Co. Winifrede, W. Va.
W. B. Berry Consolidated Gas Supply Corp. Clarksburg, W. Va.	Thomas J. Crocker U.S. Bureau of Mines Spokane, Wash.
L. M. Bianchi West Virginia University Morgantown, W. Va.	Robert Dalzell U.S. Bureau of Mines Pittsburgh, Pa.
Cloyd Blankenship U.S. Bureau of Mines Mt. Hope, W. Va.	J. G. Davis Continental Oil Co. Morgantown, W. Va.
W. T. Boyd U.S. Bureau of Mines Frankfort, Ky.	Russell L. Dawe Department of Mines and Minerals Springfield, Ill.

Maurice Deul
U.S. Bureau of Mines
Pittsburgh, Pa.

Robert L. Dodd
West Virginia Department of Mines
Charleston, W. Va.

John C. Draper
Duquesne Light Co.
Pittsburgh, Pa.

William E. Eckard
U.S. Bureau of Mines
Morgantown, W. Va.

Pete Ferguson
Bethlehem Mines Corp.
Johnstown, Pa.

H. H. Fields
U.S. Bureau of Mines
Pittsburgh, Pa.

Dennis Frailey
Old Ben Coal Corp.
Chicago, Ill.

D. Geary
Fenix Scissons
Tulsa, Okla.

Thomas Glover
U.S. Bureau of Mines
Springfield, Ill.

James R. Gray
Bethlehem Mines Corp.
Barrackville, W. Va.

Charles A. Gregory
Westmoreland Coal Co.
Tams, W. Va.

R. H. Hamrick
Westmoreland Coal Co.
Big Stone Gap, Va.

Dick Harris
Loffland Bros. Co.
Tulsa, Okla.

Stephen P. Harrison
Consolidation Coal Co.
Glendale, W. Va.

R. E. Havener
Mine Safety Appliances Co.
Pittsburgh, Pa.

Ray M. Henderson
Consolidation Coal Co.
Morgantown, W. Va.

R. Hidalgo
West Virginia Geological Survey
Morgantown, W. Va.

John Hymes
U.S. Bureau of Mines
Beckley, W. Va.

James I. Joubert
U.S. Bureau of Mines
Pittsburgh, Pa.

George L. Judy
George L. Judy Assoc.
McLean, Va.

A. L. Julian
U.S. Bureau of Mines
Pittsburgh, Pa.

J. D. Kalasky
Island Creek Coal Co.
Cleveland, Ohio

James Kish
U.S. Steel Corp.
Gary, W. Va.

F. N. Kissell
U.S. Bureau of Mines
Pittsburgh, Pa.

J. H. Kelley
West Virginia University School of
Mines
Morgantown, W. Va.

Tony B. Kitzmiller
Consolidation Coal Co.
Wana, W. Va.

W. J. Kmetz
Y & O Coal Co.
Martins Ferry, Ohio

C. A. Komar
U.S. Bureau of Mines
Morgantown, W. Va.

John Kost
Bituminous Coal Research
Monroeville, Pa.

Alex Kott
Youngstown Sheet & Tube Co.
Nemacolin, Pa.

Bill Knepp
Capata Coal Corp.
Sharples, W. Va.

Stephen Krickovic
U.S. Bureau of Mines
Pittsburgh, Pa.

William Laird
Eastern Associated Coal Corp.
Pittsburgh, Pa.

Emmett T. Lang
Tunnelton Mining Co.
Johnstown, Pa.

James E. Lough
U.S. Bureau of Mines
Monroeville, Pa.

Charles M. McCulloch
U.S. Bureau of Mines
Pittsburgh, Pa.

Roger McHugh
Duquesne Light Co.
Greensboro, Pa.

A. C. McInnes
Mine Safety Appliances Co.
Pittsburgh, Pa.

Ray Mazza
Continental Oil Co.
Morgantown, W. Va.

Paul Meek, Jr.
Westmoreland Coal Co.
Madison, W. Va.

H. Lester Merrifield
Bethlehem Mines Corp.
Barrackville, W. Va.

Donald F. Metheny
Bethlehem Mines Corp.
Bethlehem, Pa.

J. D. Micheal
U.S. Bureau of Mines
Morgantown, W. Va.

T. D. Moore
U.S. Bureau of Mines
Pittsburgh, Pa.

Keith Morgan
George L. Judy Assoc.
McLean, Va.

Charles H. Myers
U.S. Bureau of Mines
Pittsburgh, Pa.

Frank H. Neely
U.S. Steel Corp.
Uniontown, Pa.

Jerry Omer
Pittsburgh & Midway Coal Co.
Madisonville, Ky.

W. R. Park
U.S. Bureau of Mines
Mt. Hope, W. Va.

James Parrott
Youngstown Sheet & Tube Co.
Coalwood, W. Va.

Martin E. Patterson
Bethlehem Mines Corp.
Bethlehem, Pa.

George Radomsky
Florence Mining Co.
Seward, Pa.

Donald E. Ralston
U.S. Bureau of Mines
Washington, D.C.

Vincent H. Ream
Christopher Coal Co.
Osage, W. Va.

Albert Sainata
U.S. Bureau of Mines
Pittsburgh, Pa.

William B. Schmidt
U.S. Bureau of Mines
Washington, D.C.

D'Arcy A. Shock
Continental Oil Co.
Ponca City, Okla.

Samuel E. Shrader
Pocahontas Fuel Co.
Pocahontas, Va.

Jimmy L. Shumate
U.S. Bureau of Mines
Mt. Hope, W. Va.

Wilbur T. Simon
Consolidation Coal Co.
Morgantown, W. Va.

D. R. Skidmore
Eastern Associated Coal Corp.
Pittsburgh, Pa.

Milford Skow
U.S. Bureau of Mines
Washington, D.C.

Paul W. Smith
Beckley Coal Mining Co.
Whitesville, W. Va.

E. N. Strang
Westmoreland Coal Co.
Big Stone Gap, Va.

William A. Thistlethwaite
U.S. Bureau of Mines
Monroeville, Pa.

Michael P. Trainor
U.S. Bureau of Mines
Pittsburgh, Pa.

Chester N. Truax, Jr.
American Mining Congress
Washington, D.C.

Clyde V. Turner
U.S. Bureau of Mines
Johnstown, Pa.

R. W. Van Dolah
U.S. Bureau of Mines
Pittsburgh, Pa.

W. J. Vicinelly
Pennsylvania Bureau Deep Mine Safety
Harrisburg, Pa.

Robert Vinson
U.S. Bureau of Mines
Pittsburgh, Pa.

John E. Weekly
U.S. Bureau of Mines
Mt. Hope, W. Va.

J. S. Whittaker
Consolidation Coal Co.
Library, Pa.

Joseph J. Yancik
U.S. Bureau of Mines
Washington, D.C.

John Yonkoske
Greenwich Colliers Co.
Ebensburg, Pa.

M. G. Zabetakis
U.S. Bureau of Mines
Pittsburgh, Pa.

Raymond D. Zinn
Interim Compliance Panel
Washington, D.C.