

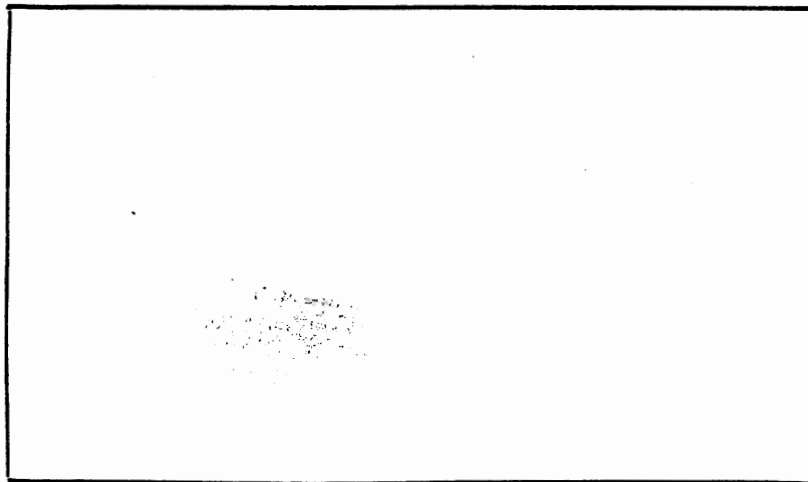

## **A.R.F. PRODUCTS, INC.**

**ENGINEERS AND MANUFACTURERS OF PRECISION ELECTRONIC EQUIPMENT**



**HOME OFFICE AND MANUFACTURING PLANT - RATON, NEW MEXICO**  
**RESEARCH AND DEVELOPMENT LABORATORY - BOULDER, COLORADO**

|   |               |   |                              |
|---|---------------|---|------------------------------|
| REPORT DOCUMENTATION<br>PAGE  | 1. REPORT NO. | 2.  | 3. Recipient's Accession No. |
| 4. Title and Subtitle<br>A Medium Frequency Wireless Communication System For Underground Mines   |               | 5. Report Date<br>Jan. 1983 (Submission                             |                              |
| 7. Author(s)<br>Dr. Larry G. Stolarczyk   |               | 6.  |                              |
| 9. Performing Organization Name and Address<br>A.R.F. Products, Inc.<br>Gardner Road<br>Raton, New Mexico 87740   |               | 8. Performing Organization Rept. No.                                |                              |
| 12. Sponsoring Organization Name and Address<br>United States Department of Interior<br>Bureau of Mines<br>4800 Forbes Avenue<br>Pittsburgh, Pennsylvania 15213   |               | 10. Project/Task/Work Unit No.                                      |                              |
|   |               | 11. Contract(C) or Grant(G) No.<br>(C) H0308004<br>(G)              |                              |
|   |               | 13. Type of Report & Period Covered<br>Final 28 Dec 79<br>31 Jan 83 |                              |
| 15. Supplementary Notes   |               | 14.   |                              |
| 16. Abstract (Limit: 200 words)<br>An underground medium frequency radio communications system has been developed and demonstrated in both coal and metal/non metal mines. The principal advantage of the system are its low cost, ease of installation and the ability to provide radio communications to any vehicle or roving miner in the underground mine. The system provides high quality radio coverage in work areas and along manways with existing "wireplant" conductors. The conductors include AC power cable, telephone cable, metal water and high pressure air pipes, etc. The measured communications range from the base station to mobile transceiver exceeded 12,500 ft without the use of repeaters. A cost/benefit analysis shows that the initial cost of the equipment can be returned 2-6 times in the first year. The mine productivity increases by approx. 13 percent. |               |   |                              |
| 17. Document Analysis a. Descriptors<br>Mines; radio communications; communications; coal mines; metal/non metal mines; radio propagation; tunnel mode, coal seam mode, wave propagation; underground mine; mine rescue radio; trapped miners; radio vest transceiver.<br><br>c. COSATI Field/Group   |               |   |                              |
| 18. Availability Statement<br>Release Unlimited   |               | 19. Security Class (This Report)<br>Unclassified                    | 21. No. of Pages             |
|   |               | 20. Security Class (This Page)<br>Unclassified                      | 22. Price                    |

USBM H0308004

FINAL REPORT

A MEDIUM FREQUENCY WIRELESS COMMUNICATION  
SYSTEM FOR UNDERGROUND MINES

HARDWARE DESIGN AND PRELIMINARY  
PERFORMANCE TESTS

INSTALLATION AND PERFORMANCE  
IN UNDERGROUND MINES

Dr. Larry G. Stolarczyk--Program Manager  
Mike Sepich, Kurt Smoker

A.R.F. PRODUCTS, INC.  
RATON, NEW MEXICO 87740

The views and conclusions contained in this document are those of the author and should not be interpreted as necessarily representing the official policies or recommendations of the Interior Department's Bureau of Mines or of the U.S. Government.

JANUARY 1983

UNITED STATES

DEPARTMENT OF THE INTERIOR

BUREAU OF MINES

## FOREWARD

This report was prepared by A.R.F. Products, Inc., Raton, New Mexico, under contract H0308004. The contract was initiated under the Mine Health and Safety Program. It was administered under the technical direction of the Pittsburgh Research Center with Mr. Harry Dobroski acting as the Technical Project Officer. Mr. Patrick Neary was the Contract Administrator for the Bureau of Mines.

This report is a summary of work recently completed as part of the contract during the period January 1980 through January 1983. This report was submitted by the author on 24 January 1983..

Applications for inventions developed in the course of the work have been filed with the Patent Office under Public Law 96-517.



## TABLE OF CONTENTS

PAGE

Foreward

List of Tables

List of Figures

### I. INTRODUCTION AND PROGRAM SUMMARY

A. OBJECTIVE

B. APPROACH

C. FINDINGS AND CONCLUSIONS

### II. SYSTEM DESIGN PLAN

A. SUMMARY

B. INTRODUCTION

C. TYPICAL ORGANIZATIONAL STRUCTURE

D. INFORMATION FLOW

E. BENEFIT ANALYSIS

F. SYSTEM ARCHITECTURE

### III. DESCRIPTION OF THE WHOLE MINE RADIO COMMUNICATIONS SYSTEM

A. SUMMARY

B. INTRODUCTION

C. MF EQUIPMENT

1. Mobile Transceivers

a. Vest Transceiver

b. Vehicular Transceiver

TABLE OF CONTENTS (CONT'D)

|   | PAGE |
|---|------|
| 2. Fixed Location - Repeater                  |      |
| 3. Base Station                               |      |
| 4. Coupling Devices                           |      |
| a. RF Line Coupler                            |      |
| b. Antenna                                    |      |
| D. FIELD MAINTENANCE                          |      |
| E. INSTALLATION                               |      |
| 1. Keyman Meeting                             |      |
| 2. Define Communication Needs<br>and Coverage |      |
| 3. Selecting Needed Networks                  |      |
| 4. Mine Map                                   |      |
| 5. Installation Plan                          |      |
| 6. Insuring System Usage                      |      |
| IV. THE SYSTEM DESIGN                         |      |
| A. SUMMARY                                    |      |
| B. INTRODUCTION                               |      |
| C. HISTORY                                    |      |
| D. NOISE GENERATED IN MINE POWER SYSTEM       |      |
| E. SIGNAL PROPAGATION MODES                   |      |
| 1. Seam Mode Propagation Theory               |      |
| 2. Transmission Line Propagation Modes        |      |

TABLE OF CONTENTS (CONT'D)

PAGE

- F. COUPLING MF SIGNALS TO THE "WIREPLANT"
  - 1. Transmitting Loop Antenna and Two-Wire Transmission Line Coupling
  - 2. Transmitting Loop Antenna To Receiving Loop Antenna Via Transmission Line Coupling
  - 3. Attenuation Rate
- G. LOOP ANTENNA DESIGN CONSIDERATIONS
  - 1. Design Optimization Process
  - 2. Antenna Area Constraints
    - a. Vest Antenna Area Constraint
    - b. Vehicular Antenna Area Constraint
  - 3. Design For Operation In Hazardous Atmosphere
  - 4. Theoretical Basis For Loop Antenna Design
- H. RF LINE COUPLER DESIGN
- I. MODULATION PROCESSES
- J. ACOUSTICAL NOISE PROBLEMS
  - 1. Overview of Microphone Noise Cancelling Theory
  - 2. Evaluation of Noise Cancelling Microphones
  - 3. Evaluation of Vest Microphones

TABLE OF CONTENTS (CONT'D)

PAGE

4. Evaluation of Vest Speakers
5. Evaluation of Acoustical Transducers on Mine Vehicles
- K. FREQUENCY PLAN AND PRESELECTOR FILTER DESIGN REQUIREMENTS
  1. Preselector Filter Network Discrimination Loss Specification
  2. Calculating The Discrimination Loss of Bandpass Filter Networks
  3. Discrimination Loss of Couplers and Antenna Filter Networks
  4. Discrimination and Dissipation Loss of the Preselector Network
  5. Designing Filter Networks
    - a. Designing Low Pass Filters
    - b. Designing A High Pass Filter From A Low Pass Prototype Network
    - c. Designing Bandpass Filters From Low Pass Prototype Filters
    - d. Designing Band-Elimination Filter Networks From Low Pass Prototype Filter Networks
    - e. Determination of the Discrimination Loss of Actual Bandpass and Band-Elimination Filters From the Discrimination Loss of a Low Pass Prototype Filter

TABLE OF CONTENTS (CONT'D)

|   | PAGE |
|---|------|
| V. SYSTEM DESIGN SPECIFICATIONS   |      |
| A. SUMMARY  |      |
| B. INTRODUCTION   |      |
| C. GENERAL SYSTEM SPECIFICATION   |      |
| D. BASE STATION AND VEHICULAR TRANSCEIVER SPECIFICATIONS                                      |      |
| 1. Standard Transceiver   |      |
| 2. Remote Control Terminal (RCT) Unit   |      |
| 3. Remote Audio Head (RAH)  |      |
| E. REMOTE CONTROL CONSOLE   |      |
| F. VEST TRANSCEIVER SPECIFICATIONS  |      |
| 1. Permissible Battery Pack   |      |
| 2. ART-29 Vest Transceiver  |      |
| G. REPEATER TRANSCEIVER SPECIFICATIONS  |      |
| 1. Repeater Block Diagram   |      |
| H. STANDARD MODULE SPECIFICATIONS   |      |
| I. RF LINE COUPLER AND ANTENNA SPECIFICATIONS   |      |
| VI. FIELD DEMONSTRATION   |      |
| A. MAGMA COPPER COMPANY, SAN MANUEL DIVISION  |      |
| 1. Magma's Communication System   |      |
| 2. The MF Communication System  |      |
| 3. Test Results   |      |
| a. Test 1 - Vest Communications To Audio Room Base Station from Grizzly and Production Levels |      |

TABLE OF CONTENTS (CONT'D)

PAGE

- b. Test 2 - Vehicular and Vest Communications To Audio Room Base Station Via Audio Conductors On Production Level
  - c. Test 3 - Vehicular Communication To Base Station Relocated To 5 Shaft (Via Dedicated Wire on 2375 Level)
  - d. Test 4 - Hoist Communications Test Base Station In Hoist Control Center
  - e. Test 5 - Hoist Communication Test Base Station At The Collar
4. Conclusion
- B. PLATEAU MINING COMPANY
- 1. Installation of MF Equipment
  - 2. Installation of Repeaters
  - 3. Test Results
  - 4. Quality and Performance
  - 5. Lessons Learned
  - 6. Demonstration Results
- C. YORK CANYON COAL MINE
- 1. Installation of MF Equipment
  - 2. Measurement Results
  - 3. Mine Rescue Communications
  - 4. Demonstration Results
-

TABLE OF CONTENTS (CONT'D)

PAGE

- D. RANCHERS EXPLORATION AND DEVELOPMENT CORP.
  - 1. Escalante Communication System
  - 2. Installation of MF Equipment
  - 3. Field Test

VII. RECOMMENDATIONS

- A. BIDIRECTIONAL AMPLIFIER
- B. REDUCE LOSS ACROSS AC POWER TRANSFORMERS AND SWITCHES
- C. BETTER WAYS TO DEPLOY TWIN-LEAD CABLE
- D. TELEPHONE SYSTEM INTERFACE NETWORKS
- E. PAGING AND EMERGENCY COMMUNICATIONS
- F. RESCUE TEAM COMMUNICATIONS
- G. HOIST COMMUNICATIONS
- H. NATIONAL EMERGENCY FREQUENCY
- I. EMERGENCY COMMUNICATIONS
- J. TRAINING MINE MANAGERS

APPENDIX A NORMALIZED DISCRIMINATION LOSS  
(NORMALIZED ATTENUATION) OF THE  
LEGENDRE TRANSFER FUNCTION

APPENDIX B DISSIPATION LOSS OF THE LEGENDRE  
TRANSFER FUNCTION

APPENDIX C 3 dB LEGENDRE FILTER ELEMENT VALUES

LIST OF REFERENCES

## LIST OF TABLES

| Table |  | Page      |
|-------|--|-----------|
| A     | Productivity Multiplier Worksheet  |           |
| B     | Overlay Frequency Plan   |           |
| C     | Cooperating Mines  |           |
| D     | Typical Equipment List   |           |
| E     | RF Line Coupler Transfer Impedance (1 Inch) (omitted)                                |           |
| F     | Induced Line Current   | (omitted) |
| G     | Comparison of Measured and Calculated<br>Twin-Coil Loop Vehicular Antenna Parameters |           |
| H     | RF Line Coupler Transfer Impedance<br>(1 Inch)                                       |           |
| I     | RF Line Coupler Induced Line Current   |           |
| J     | Measured Sound Pressure Level Of<br>Mining Machines                                  |           |
| K     | Measured Articulation Index  |           |
| L     | Recommended Microphone and Speakers For<br>Use In Underground Mines                  |           |
| M     | Signal Path Power Level and Discrimination<br>Loss                                   |           |
| N     | Standard Transceiver Specifications  |           |
| O     | Remote Control Terminal (RCT) Specifications   |           |
| P     | Remote Control Head (RCH) Specifications   |           |
| Q     | Remote Control Console (RCC) Specifications  |           |



LIST OF TABLES (CONT'D)

| Table |   | Page |
|-------|---|------|
| R     | Vest Transceiver Specifications   |      |
| S     | RF Line Coupler Specifications  |      |
| T     | Antenna Specifications  |      |
| U     | Vest Transceiver Communications To<br>Audio Room Base Station (Via 2315 and<br>2375 Level Audio Cables)   |      |
| V     | Vehicular and Vest Communications To Audio<br>Room Base Station (Via Main Haulageway<br>Audio Conductors) |      |
| W     | Vest and Vehicular Communications To 5<br>Shaft Base Station  |      |
| X     | Hoist Communications Signal Level Cage To<br>Base At The Drum   |      |
| Y     | Hoist Communications Signal Levels Cage To<br>Base At The Collar  |      |
| Z     | Signal To Noise Ratio Measurements At Base<br>Station From Repeater Locations                             |      |

## LIST OF FIGURES

| Figure No. |  | Page |
|------------|--|------|
| 1          | Formulation of the System Design Specifications              |      |
| 2          | Typical Organization Chart                                   |      |
| 3          | Typical Production Profile                                   |      |
| 4          | System Architecture  |      |
| 5          | Radio Coverage Cells in an Underground Mining Complex        |      |
| 6          | The "Near" Magnetic Field Radio Communications System        |      |
| 7          | Use of Base Station and Repeater                             |      |
| 8          | Radio Coverage Cell at the Face                              |      |
| 9          | F1/F2 Signalling   |      |
| 10         | Vest Transceiver   |      |
| 11         | Vest Control Head  |      |
| 12         | Vehicular Transceiver  |      |
| 13         | Repeater Transceiver   |      |
| 14         | Remote Control   |      |
| 15         | Remote Control Console                                       |      |
| 16         | RF Line Coupler  |      |
| 17         | Tuned Loop Antenna   |      |
| 18         | System Planning Guide  |      |
| 19         | RF Line Coupler Installation                                 |      |
| 20         | Base Station and Repeater Control Cable Installation Diagram |      |

LIST OF FIGURES (CONT'D)

| Figure No. |  | Page |
|------------|--|------|
| 21         | Seam Mode Field Components   |      |
| 22         | Signal Current (I) Flow on Conductors (n=2)  |      |
| 23         | Geometries For a Vertical Transmission Line and Transmitting Loop Antenna                |      |
| 24         | Equivalent Transmission Line Network For Induced Voltages and Currents ( $Z_1=Z_2=Z_0$ ) |      |
| 25         | Signal Coupling to a Receiving Loop Antenna  |      |
| 26         | Set Up For Measuring Induced Line Current  |      |
| 27         | Induced Line Current Versus Vehicular Transceiver Distance From Base Station             |      |
| 28         | Transmitting Loop Antenna Excitation Current and Magnetic Moment                         |      |
| 29         | Collins Prototype Portable MF Transceiver  |      |
| 30         | South African Portable Transceiver   |      |
| 31         | Twin Coil Transmitting Loop Antenna  |      |
| 32         | Parallel Equivalent Circuit of a Single Coil Loop Antenna                                |      |
| 33         | Unloaded Q Versus Frequency for a Flexible Rectangular Tubular Lexan Antenna             |      |
| 34         | Unloaded Q Versus Frequency for a Flexible Rectangular Planar Lexan Antenna              |      |
| 35         | Typical Matching Network   |      |
| 36         | Inductive Coupling in the Twin-Coil Loop Antenna   |      |

## LIST OF FIGURES (CONT'D)

| Figure No. |  | Page |
|------------|--|------|
| 37         | Equivalent Circuit of the Twin-Coil Loop Antenna   |      |
| 38         | RF Line Coupler  |      |
| 39         | Signal Coupling From the "Wireplant" (Cylindrical coordinates $r, z, \phi$ )             |      |
| 40         | Test Set-Up for Measuring Induced Current as a Function of Line Resistance ( $R_L$ )     |      |
| 41         | Over the Earth Multiple Wire Coupling  |      |
| 42         | Typical Modulation Process Gain  |      |
| 43         | Acoustical Noise Comparisons   |      |
| 44         | The Vought Second Order Microphone Technique   |      |
| 45         | Normalized Noise Frequency Response At A Gradient Microphone                             |      |
| 46         | PVF2 Noise Cancelling Microphone and Circum-Aural Ear Cup Speakers Mounted On Miners Cap |      |
| 47         | Hard Hat Mounted Speakers  |      |
| 48         | Digital Frequency Synthesizer Tuning Elements  |      |
| 49         | Transmitter To Receiver Isolation  |      |
| 50         | Comparison Of The Discrimination Loss Of Well Known Transfer Functions (5th Order)       |      |
| 51         | Low Pass Prototype Filter  |      |
| 52         | Legendre Band Pass Filter Discrimination Loss For Orders $n=3,5,7$ and $9$               |      |

LIST OF FIGURES (CONT'D)

| Figure No. |  | Page |
|------------|--|------|
| 53         | Legendre Band Elimination Filter<br>Discrimination Loss For Orders<br>n=3,5,7, and 9 |      |
| 54         | Base Station And Vehicular Transceiver<br>Block Diagram                              |      |
| 55         | Block Diagram Of Remote Control Terminal<br>(RCT) Unit                               |      |
| 56         | Remote Audio Head (RAH) Block Diagram  |      |
| 57         | Remote Control Console (RCC)   |      |
| 58         | Vest Transceiver Block Diagram   |      |
| 59         | Block Diagram Of Permissible Battery Pack  |      |
| 60         | Front and Rear Views Of Vest Transceiver   |      |
| 61         | Repeater Block Diagram   |      |
| 62         | Grizzly And Production Level Drifts  |      |
| 63         | Illustration Of Loader And Motorman<br>Loading Train                                 |      |
| 64         | Magma Communications Resources   |      |
| 65         | Mine Map Of Production Level   |      |
| 66         | Mine Map Of Grizzly Level  |      |
| 67         | Illustration Of Hoist Communications System  |      |
| 68         | Simplified Drawing Of The Plateau Mine   |      |
| 69         | Photograph Of Vehicular Transceiver<br>Installation                                  |      |
| 70         | Photograph Of Vehicular Antenna<br>Installation                                      |      |

LIST OF FIGURES (CONT'D)

| Figure No. |  | Page |
|------------|--|------|
| 71         | Simplified Plan View Drawing Of The York Canyon Mine                                   |      |
| 72         | Cross Section Of Manway (Looking Inby)   |      |
| 73         | Installation Of RF Line Coupler  |      |
| 74         | Photograph Of The Tera Jet Jeep Antenna Installation                                   |      |
| 75         | Induced Line Current Versus Vehicular Transceiver Distance From Base Station           |      |
| 76         | Radio Coverage Area At Cross Cut 31 Along Manway (3100 Feet From Base Station)         |      |
| 77         | Radio Coverage Area At Cross Cut 91 Along Manway (9100 Feet From Base Station)         |      |
| 78         | Plan View Of Transmission Line Aided Radio Coverage (Pair of Insulated #16 Conductors) |      |
| 79         | Redco Silver Ore Body  |      |
| 80         | Plan View And Entry Cross Section Of The 4970 Level Drill Sub-Level North Undercut     |      |
| 81         | B-B' View Of The Ore Body (VCR Mining)   |      |
| 82         | System Block Diagram   |      |
| 83         | Redco Silver Mine Haulage Drifts   |      |
| 84         | Emico Truck Showing Vehicular Antenna  |      |
| 85         | Circum-Aural Ear Cups  |      |
| 86         | Induced Line Current Versus Vehicular Transceiver Distance From Base Station           |      |
| 87         | Use Of Cap Lamp Receiver For Emergency Communications                                  |      |
| 88         | Location And Rescue By Medium Frequency Techniques                                     |      |
| 89         | Basic MF Communications Between Rescue Team Members                                    |      |

## I. INTRODUCTION AND PROGRAM SUMMARY

### A. OBJECTIVE

The objective of this work was to design, develop and construct Medium Frequency (MF) communications equipment's for demonstration in operating underground mines.

Recent theoretical and experimental radio wave propagation work conducted under the sponsorship of the U.S. Bureau of Mines (USBM) determined that low loss electromagnetic wave propagation modes exist in MF frequency band (300 to 1000 kHz). Using these modes, cells of radio coverage can be provided along the entries and in the working areas of an underground mine. Since the wave propagation modes take place because of the natural physical configuration of the mine, the transmission medium is already in place in the nation's underground mines.

In previous work the USBM determined that commercially available VHF and UHF radio communications equipment either was limited in coverage or required the installation of leaking feeder cable and repeaters. Although the leaky feeder communications system provided acceptable coverage along the entries (with leaky feeder cable), it failed around corners, through barracks, rock falls, etc.

The principal advantage seen by the USBM for the MF system was its low cost, ease of installation and the ability to provide radio communications to any vehicle or roving miner in the underground mine.

Because the necessary MF radio equipments needed to construct a whole mine communication system were not available on the market, the USBM initiated this program.

#### B. APPROACH

First, radio communication needs of coal and metal/non-metal (M/NM) mining organizations were determined by systematically analyzing the structure, functioning, performance of organizations and the behavior of groups and individuals within them. Drawing together this background information and synthesizing the conclusions as to how the organization efficiency could be improved with radio communications, a system design plan meeting the present and future needs was formulated. This plan was used in developing block diagrams and specifications for each equipment needed in the system.

Upon completion of the system design plan, the effort was directed in two related areas. First, the work focused on solving problems related to environmental and human factors and involving the use of electronic equipment in mining.



Since the environmental, human factors and communications problems are so unique in mining, new thinking was required in the equipment design approach to realize an acceptable system. Lessons learned in developing radio equipment for military applications were sought out, evaluated and applied, where practical in the design of the equipment. Secondly, breadboards for each MF equipment were designed and built. As an extension of our laboratory evaluation, breadboards were evaluated in nearby mines. Weak points in the design were resolved, resulting in a final design specification.

Next, prototype equipments were manufactured and laboratory tested for compliance with the specifications.

Finally, the MF equipment was installed and made operational in four (4) mines. The four Western mines that agreed to participate in the system demonstration program were: Ranchers Exploration and Development Corp., Redco Silver Mine, Enterprise, Utah; Kaiser Steel Corp., York Canyon Coal Mine, Raton, New Mexico; Getty Oil Company, Plateau Coal Mine, Price, Utah; and the Magma Copper Company, San Manuel Division, San Manuel, Arizona. The size of the mines ranged from small (500 tons/day) to large (67,000 tons/day) and represented mining methods in common use in the U.S. mining industry. The performance of the whole mine communications system was evaluated in each of the mines during many months of field testing.

### C. FINDINGS AND CONCLUSIONS

The MF communication systems that were installed in the demonstration mines provided high quality radio coverage in work areas and along manways with existing "wireplant" conductors. The conductors include AC power cable, telephone cable, metal water pipe and high pressure air pipe, etc.

Excellent system performance was due in part to technological improvements achieved in the design of radio equipment for use in underground mining environment. Field testing lead to new discoveries about the characteristics and use of radio communications in mining. The discoveries will increase productivity, improve management performance and organizational team work, and reduce maintenance cost. Use of radio will make the mine a safer place to work. Radio will also revolutionize mine search (trapped miner location), and rescue team methods.

Many important technological contributions to underground radio technology occurred in this work. First, highly efficient antennas and electrical conductor coupling devices were developed and evaluated in each mine. A unique antenna design featuring a twin-coil planar antenna structure achieved high magnetic moment, a fundamental requirement for inducing high level carrier currents in nearby electrical conductors. The optimized antenna design was also shown to be a highly sensitive device for receiving weak underground radio signals.

The air-core toroidal RF line coupler achieved high coupling efficiency to the existing mine conductors. The efficient antenna and coupler designs are partially responsible for the excellent performance of the communications systems in the mines. Secondly, the use of high sensitivity superhetrodyne receiver design, that performed well in the high acoustical and electrical noise environment of the mine, was a major factor in receiving MF signals at great range from a base station location. Finally, the development of a small light weight transceiver that can be sewn into the miners' work clothing solved an important human factor problem associated with the use of personnel carried transceivers in mining. From the point of view of comfort and convenience, the transceiver was sewn into a vest garment. The transceiver modules were distributed on the vest to reduce bulkyness. The vest did not in anyway restrict the miner's movement in tight quarters. The vest design features unique circuit to enable use in hazardous atmosphere encountered in both coal and some metal/non-metal mines. The vest design has been approved by the Mine Safety and Health Administration.

The radio communication systems were installed in mines with the principal goal of solving a wide variety of communications related problems. The problem ranges from those associated with equipment installation and survivability

in the mine environment to providing radio coverage in varying situations likely to be found in mining practice. Another goal was to determine the benefit of radio in the mining process.

The communications range from the base station location (usually at the mine portal) to mobile transceivers in the manways (with conductors) was measured in miles. The same range was found to exist between mobile transceivers. A remarkable discovery was observed in the "listening" (receiving) range of a transceiver. MF signals can be received everywhere conductors exist in the mining complex. Transceivers in the surface office complex can listen to MF radio transmissions occurring in the underground mine. This occurred even when the conductors were not intentionally "illuminated" by the antennas and couplers. Thus, MF signals are distributed by natural coupling existing between conductors in the mine wiring. This discovery will have broad implications in trapped miner and rescue technology. In a layered formation like coal, the talk-back (transmitting) range included adjacent conductor less manways. It is difficult to make accurate radio signal propagation measurements in any mine, none the less measurements were made in every mine. The MF signal to noise ratio was measured at the base station location. The measured ratio frequently exceeded 50 dB

when a mobile transceiver was a mile or more from the base. Since a 20 dB ratio provides good intelligibility, voice quality was remarkable. The attenuation rate measured along the AC power cable and telephone cable was less than 4 dB/1000 feet. Considering the ratio and the MF signal attenuation rate, operating range from a base will be greater than 12,500 feet. AC power transformers add approximately 10 dB to the transmission loss. AC switches and transformer loss makes AC power cable a lower quality and less reliable MF signal distribution network.

High quality and reliable MF signal distribution can be provided by installing low cost twin-lead cable in conductorless or AC power cable manways. Communications range will exceed 15,000 feet along the cable. Another extremely important aspect of the MF system is its ease of installation. Preliminary demonstrations to mining companies required less than 5 minutes of installation time. Permanent installation of all equipment and any twin-lead cable can be accomplished in a few hours.

In every mine, unique communication problems were encountered and easily solved with the MF equipment. The multiple level Magma Copper Mine uses the block caving mining process. Mucking occurs on the grizzly level. Trains are loaded on the production level. Radio communications were

extended to battery powered service vehicles and off-train men. Roving miners with vest transceivers were able to communicate from the grizzly and production levels to the surface control center. The use of radio enabled front line production foreman to better coordinate mucking activities. Hoist communications were also evaluated. Instead of "illuminating" the hoist wire rope at the sheave wheel location, as is common practice with the commercially available equipment, the highly efficient vehicular antenna was used to "illuminate" the wire rope at the collar. The RF coupler was clamped (like a current probe) around the wire rope just above the cage. The signal to noise ratio was measured as the cage traveled in the shaft. The signal to noise ratio exceeded 100 dB.

The medium sized York Canyon coal mine employs conventional as well as longwall mining technology. The Plateau Coal Mine uses conventional mining methods. Both mines use conveyor belt haulage. Vehicular transceivers were installed on diesel and battery powered service vehicles. Maintenance personnel and beltmen were assigned vest transceivers. Radio coverage included all manways and the entire longwall in the York Canyon Mine. The base was located at the portal. The talk-back (transmitting) range was limited to manways

with telephone cable or AC power cable. The range exceeded 15,000 feet. In some instances, the talk-back range extended to drifts adjacent to the manways. The listening (receiving) range included all manways with conductors. Repeaters were not required in the mine. The Plateau Mine working faces are more than three miles from the portal. The base station was located at the one mile point and repeater transceivers were installed near the working faces. In this mine, the primary MF distribution signal network was AC power cable. Some of the manways did not include AC cable. Radio coverage in manways with cable was excellent (exceeded 50 dB). However, twin-line cable was required in the conductorless manways.

The Redco Silver Mine uses a modified vertical crater retreat (VCR) mining method developed in Canada. Articulated rubber tired vehicles transport muck out of the mine. Radio communications to the motormen was excellent.

The primary conclusion to be drawn from this work is that the MF radio communications system is a productivity and safety multiplier. Actual experience with the system in these mines shows that the keyman "reach" time has been reduced from an average of 35 minutes to seconds.

Keymen receive first hand information instead of second hand information. More importantly, radio significantly improves team work, a factor of significant importance in improving productivity and safety. Our studies show that the existing telephone system, by its inherent limitation, isolates keymen from the main mine communications resource most of the time. By being isolated, roving miners retain their independence. The price paid for independence by the mining company is low productivity. Things do not have to be as they are in underground mining. Experience in the field tests show that radio improves information flow rate, replacing independence with team work in the working group. The availability of vital information, through the radio communications resource, will enable miners to better coordinate their activities and instantly reorder work priorities when required during a working shift. An exceedingly important organizational benefit is that the use of radio creates a definite sense of "belongingness" in the working groups and in the mine organization. Because of "belongingness", miners affiliate more closely with the organization - this permotes team work.

Cost/benefit analysis shows that the initial cost of equipment can be returned 2.6 times in the first year. Total mine productivity will increase by approximately 13 percent.



Mines wishing to install and use radio can following the step by step planning guide given in Chapter III, Section D, of this report. Lessons learned in the demonstrations included the fact that management must be active in the initial planning of the system and must insure its initial use. Bear in mind that miners are accustomed to working independently. They will prefer to keep it that way. Trained maintenance personnel are required to keep the system in top working order. The equipment used in the system has been designed for high reliability and ease of troubleshooting by anyone with previous radio experience. The radio equipment was designed around a standard set of plug-in modules. Troubleshooting skill level is only to the board level.

## II. SYSTEM DESIGN PLAN

### A. SUMMARY

The system design plan was formulated during Phase I time period of this project. The design plan included a definition of the system architecture, operating features and performance specifications. The plan was formulated by an iterative process of market and system research. The process is illustrated in Figure 1.

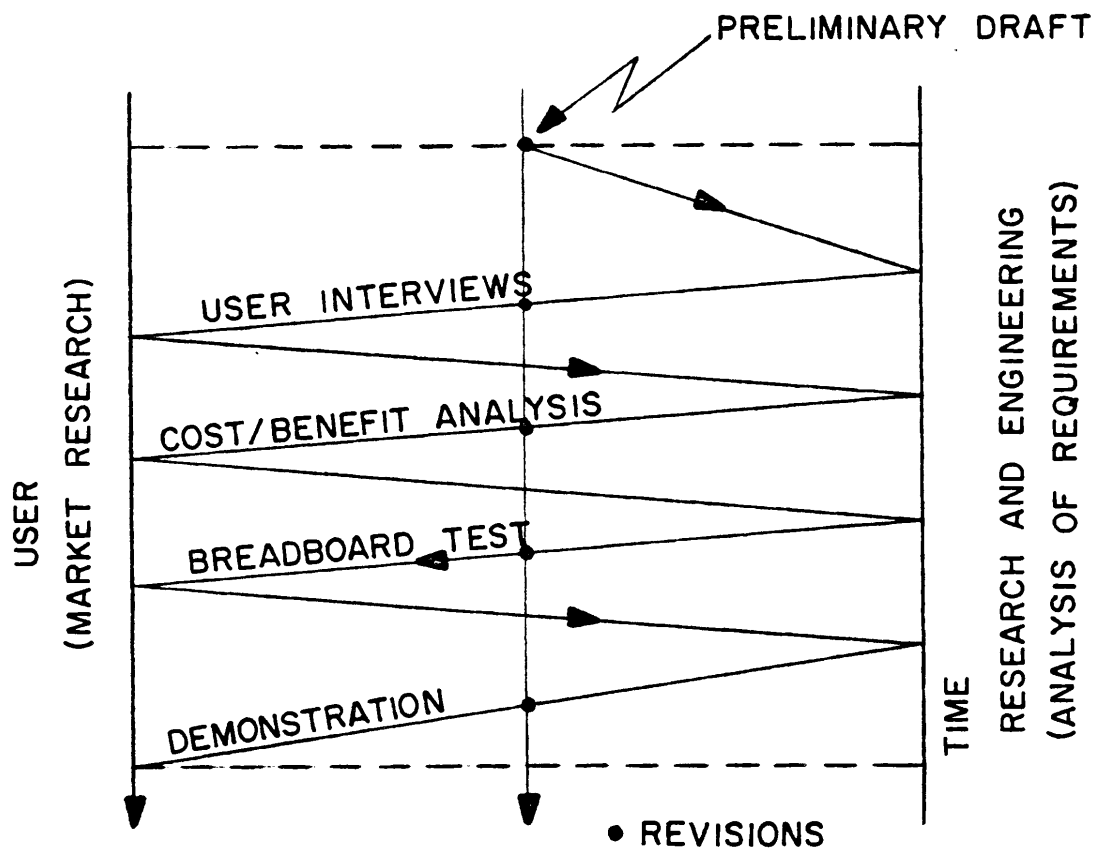

FIGURE 1 FORMULATION OF THE SYSTEM DESIGN SPECIFICATIONS (1)

The first step in the iterative process was the formulation of a preliminary draft of the system design plan by the program Research and Engineering (R and E) group. R and E group developed seminar materials (35mm slides of the system concept, mock-up models of personal transceivers, etc.) for presentation to different levels of management and operating personnel in both small and large coal and M/NM mining organizations. In all, twelve seminars were conducted at mines across the United States. The seminars succeeded in correctly defining the communications needs, equipment installation constraints, human factor problems, and the hostile mine environment conditions. During each seminar, forecast of the economic benefit of using radio were made with the cooperation of mine personnel. Production rates (tons/hour) were determined for each component of the mining process. Components that exhibited significant differences in maximum to actual (prior 12 month average) rate were examined to determine how radio could be used to improve the actual rate and reduce mining cost. With this vital information, the R and E group was able to tailor the system design to maximize benefit.

Finally, as an extension of the laboratory aspect of the R and E work, breadboard models of the radio equipments were evaluated in nearby mines.

Users indicated that the communication needs in coal and metal/non-metal (M/NM) mining organizations are different. However, there also exist many common needs. The most important common communications need was to create a radio communications link between the maintenance foreman and his crew. Radio communications must be provided to the point of equipment break-down and to service vehicles that transport vital repair parts. The second most important need was to improve communications between keymen to better coordinate the production task. Production supervisors must have the capability of altering work priorities as conditions change in the mining process during the working shift and to communicate with the maintenance foreman. Radio links must exist between the superintendent, front line foremen and other keymen. Maintenance and production communications networks are required in every mine. It was found that these networks should exhibit a party line characteristic so that all members of the working group have the same information. Separate networks are required for coordinating and directing haulage traffic and hoist operations.

The communication networks must be distributed in the sense that each network can be operated independently of the other networks. The design of radio equipment must withstand the hostile mine environment and not be onerous to roving miners.

## B. INTRODUCTION

Mine managers and engineers are driven in their thinking by production and safety concerns. They know that a safe mine is a productive mine. Attitudes are forged by the realization that more must be attempted than can be done with existing methods in any eight (8) hour shift. Further, they perceive that productivity and safety are greatly influenced by the geology of the formation, the mining process, type and maintainability of the mining equipment, the attitudes of the work force, effectiveness of the communication resources used in the mining organization, etc. Within their individual training experience and organizational constraints, managers do all that they can do to minimize mining cost.

Methods of enhancing productivity in modern day industry have been extensively studied and evaluated by researchers in many different disciplines. Researchers in the field of organization theory are concerned with structure, functioning, and performance of organization and the behavior of groups and individuals within them (2). Successful managers tend to equally concentrate their attention on three (3) productivity factors:

1. The application of advanced technology and improvement skills.

2. The systematic ordering of operations to minimize overall production cost.
3. The organization of team work.

The first factor tends to capture the interest of most managers. Managers and engineers by training and experience are able to relate technology improvements to improved productivity. In order to be informed of latest technological advances, they eagerly attend shows of mining equipment and read trade publications. They spend a great deal of time evaluating improvements in their mining process. The second factor is well developed in almost every organization. In general, managers are able to organize the physical plant and processes for near optimum operations. The third (team work), by comparison with the other two, is almost wholly neglected. Yet it remains true that if the three key factors are out of balance, the organization as a whole will not be successful. The first two operate to make an organization effective, the team work makes it efficient.

The organization of team work and its effect on productivity was studied by Mayo (4) in the now famous Hawthorne Case. This study showed that a close relationship of the working group with management was a key factor in improving productivity. As management worked more closely with members of the working group, productivity increased. In 1948, Bavelas (5) considered the relationship between the behavior

---

of small working groups within an organization and the patterns of communications (6). The group structure consisted of cells connected one to the other. What defines a pattern is the way cells are connected. The purpose of the work was to consider the psychological conditions that are imposed upon the group members by various communication patterns and the effects of these conditions on the organization and the behavior of its members (7). The concept of centrality became the chief determinant of behavioral differences because centrality reflects the extent to which a miner is strategically located relative to his source of information in the pattern. Centrality derives from the belief that the availability of information necessary for the solution of the problem will be of prime importance in affecting the miner's behavior. Centrality is a measure of a person's closeness to all other group members, and hence is a measure of the availability of information necessary for solving problems. It is quite easy to see how the availability of information affects behavior within a working group. An individual who can rapidly collect information will be seen by others in a different way from an individual to whom vital information is not accessible in a reasonable time period.

The study of how information flows through a mining organization is interesting since it affects the design of a whole mine radio communications system. Further, the study will show how the system is to be designed to improve centrality in the mining organization.

### C. TYPICAL ORGANIZATIONAL STRUCTURE

Through the years, mining companies have organized into pyramidal type of organizational structures. The structure is similar in many ways to organizational charts found in industrial firms producing a constant product over a long period of time.

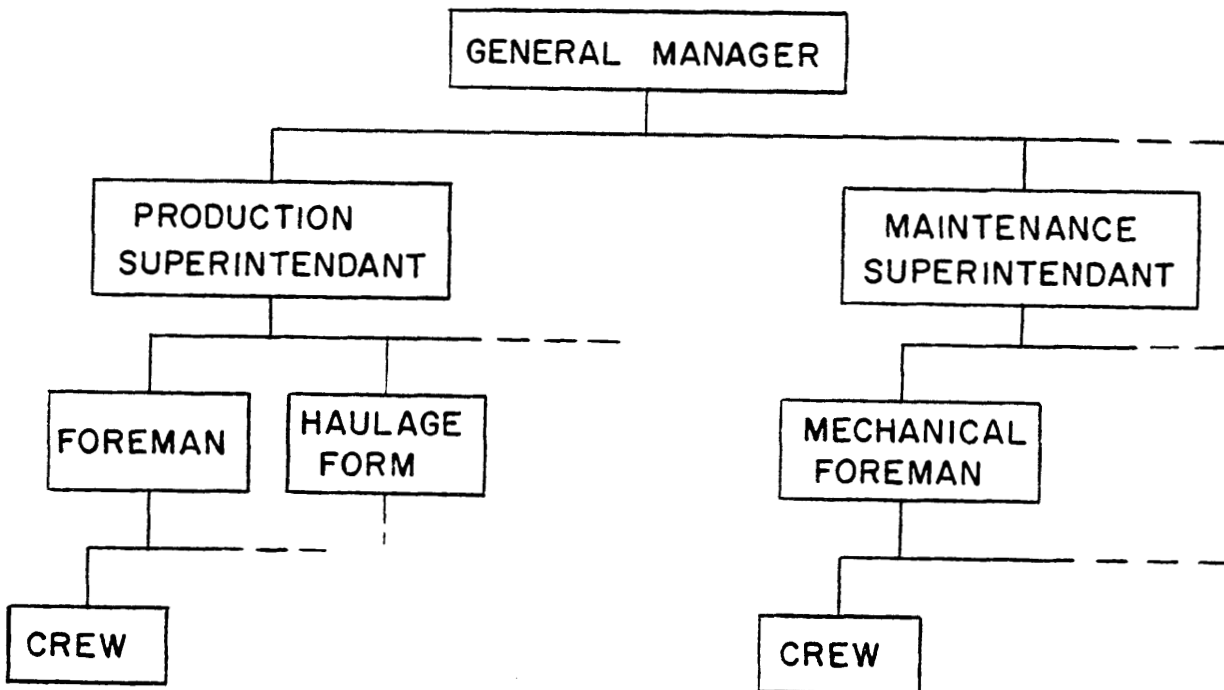

FIGURE 2. TYPICAL ORGANIZATION CHART



Underground miners are organized into small semi-autonomous working groups (crews) (4). The groups accomplish specific tasks necessary in the mining process. The location of the crews in the mining complex depends upon the task. For example, production crew members spend most of their time in the working section (face, stope, etc.). By way of contrast, maintenance crew members may be anywhere in the mining complex.

Keymen are responsible for a smooth running mine. The superintendent coordinates and directs mining activity through his foremen. The foreman directs the working group.

The efficiency of organization is measured in terms of product tonnage produced per man-shift.

#### D. INFORMATION FLOW

It is well known that the communication resources employed in the Nation's underground mines have remained relatively unchanged over the past two decades. It is interesting to observe that this occurred during a period of high rate of technological change in new extractive technology and equipment. The reason for this is threefold. First, management and mine equipment manufacturers understand that bigger-better-automated mining equipment improves the machine component of productivity. Secondly, managers perceive that they have maximized the human component of productivity (in some cases, "beat the union horse to

death"). Finally, most managers are not radio communications specialists. They fail to perceive how radio can be a productivity multiplier.

In the present day mining organizations, information flows by several communication methods. At the beginning of each shift, the superintendent and foremen meet to outline the work task, objectives and priorities. Foremen relay vital information to members of their crews. During the working shift, the pager telephone system becomes the primary communications resource.

Based upon the work of Bavelas, centrality is expected to be a measure of productivity. This has been confirmed in the course of this work by observing group management activities during shift changes in several coal and M/NM mines. In high productivity coal mines (greater than 25 ton/man-shift), meetings were held at the beginning of each shift. The meeting included all superintendents and foremen belonging to the in-and-out-going shifts. Some of the crew members were also present. Members of the management team freely discussed problems encountered on the prior shift. The likelihood of the problems emerging again on the next shift were also discussed. By their presence, maintenance crews were apprized of possible problems. Repairs were scheduled to avoid production down time. In one mine a "crash" vehicle containing emergency repair parts was stationed underground

and used in emergencies by the maintenance crew. It was interesting to note that the face production crew on the outgoing shift left the mining equipment in position to reduce start up time for the next crew. In lower productivity mines, the meetings at the beginning of a shift were noteworthy in the sense that they tend to be "by chance" one-on-one encounters between the superintendent and his own foremen. Thus, lower centrality occurs in a low productivity mine.

Although management and other mine personnel have wished to use radio to improve production rate, the pager telephone system remained the only available communications resource. Lack of coverage in the mining complex was management's most frequent criticism of the system. Timely messages needed for adequate coordination fail to reach keymen. The lack of good communications in the developing years of modern mining processes, has contributed to many unsound mine management practices. Interviews with mine supervisory personnel emphasizes some of the problems. One superintendent said "I don't need radio, I have the Bell System - if my foreman doesn't know what he is doing, I'll fire him". Another said, "We have gotten along without radio so far, we don't need it. The reason I work underground is that I am not hastled by management".

These statements are noteworthy in several respects. First, they confirm the fact that experienced miners (the ones that have not been fired!) know how to do their job - they only need to communicate when unexpected events occur. Secondly, communication from the superintendent to the foreman tends to be autocratic. "Go fix...", etc. Since no one likes to receive autocratic messages, miners in working groups are "satisfied" with the poor telephone coverage. By being isolated from the information source most of the time, roving miners retain their independence. The price paid for independence is low centrality and productivity. Things do not have to be as they are in underground mining. Radio can be used to increase centrality, replacing independence with synergism<sup>(1)</sup> in the working group. The availability of vital information, through the radio communication resource, will enable the miners to coordinate their activity and create a definite sense of "belongingness" in the working group and the mining organization.

(1) Synergism - Cooperative action of individual working groups such that the total effect is greater than the sum of the two effects taken independently.

## E. BENEFIT ANALYSIS

Users indicated that the communication needs in coal and M/NM mining organizations are quite different. However, there also exists many common needs.

In coal, production depends strongly on the availability of face equipment. Potentially more coal can be mined than can be transported out of the mine.

The Jet Propulsion Laboratory (JPL) and others have extensively studied the effects of equipment down time on productivity (8) (9). Their work shows that the down-time period tends to increase with the complexity of the mining equipment. Increased complexity also requires greater proficiency on the part of the maintenance crew members. In some mines, the proficiency of new maintenance crew members is suspect and repair burdens have been found to be shifted to others (skilled repairmen and supervisors). The average availability time of 35 continuous miners studied in the JPL work was 73% of the face time (production shifts less travel time). The availability of the longwall section was found to be near 76%. These figures exclude time lost to travel, scheduled maintenance, moving equipment, etc. Hence the availability is often less than 50%. In metal/non-metal mining, productivity is also dependent upon the equipment breakdown factor. In this case, the factor is the availability of the haulage system. The effect of mining equipment down-time on productivity is shown in the figure below.

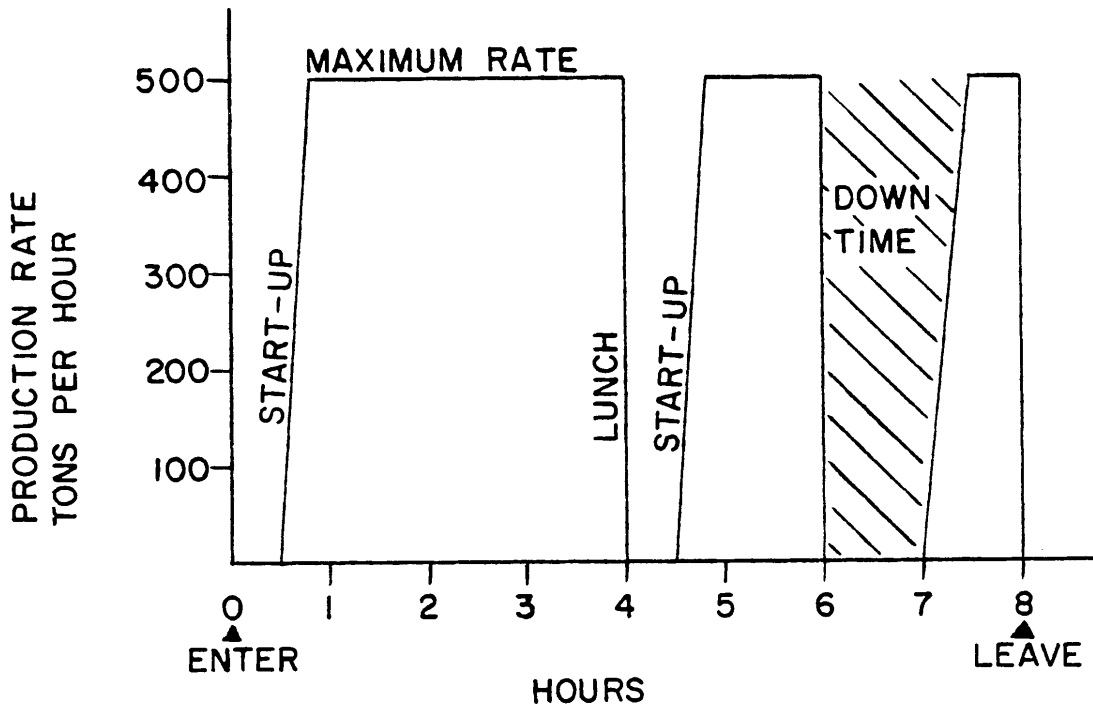

FIGURE 3. TYPICAL PRODUCTION PROFILE

Productivity is naturally lost during scheduled start-ups, lunch breaks and shift change activities. As Figure 3 shows, unscheduled down time has a significant effect on productivity. The cost of down time depends upon the failure point in the mining process. Failure in a working section may range from a few thousand dollars per hour to tens of thousands of dollars per hour on the main haulageway system. Thus the system cost can be justified by saving only a few production hours.

The use of radio will enhance productivity and safety in the following ways:

1. The average time to reach a keyman with the pager telephone system in both coal and M/NM mines is 35 minutes. This statistic was established by placing a call (paging) to both superintendents and foremen in the mine and measuring the reply time interval.

Breakdowns occurring at the face or on the haulageway require communications between keymen to resolve the matter. As a result, mining equipment down time depends upon the "reach time". Assuming that at least one breakdown occurs per shift, radio communications between maintenance and production keymen will reduce down time by 35 minutes per shift.

2. Because of the "reach time", critical telephone messages must frequently be relayed by others. Thus keymen frequently receive inaccurate information. This costs more than most mine managers realize.

In one mine clean-up operation, wayside litter was gathered and shipped out of the mine on two coal cars. Seventy-five percent of the litter was in fact vital repair parts. Frequently, a wrong part is ordered from the warehouse and delivered to the point of equipment breakdown. Sometimes the part is delivered to the wrong location. Thus, the use of radio will lower the real cost of repairs.

3. The single channel audio paging telephone system has been upgraded in recent years. Direct dial multiple channel (star and branch networks) telephone systems have been installed in mines to improve communications. Maintenance crew members preferred the single channel party line pager telephone system. By listening to audio pagings, crew members were able to determine status of breakdown problems in the entire mine. Although this change is viewed by management to be "good", it actually decreased centrality in the maintenance group. Radio will dramatically increase centrality in the maintenance group.

4. Serious accidents and fatalities occur in underground mining because of poor communications. Radio links must be established between all vehicular motormen and off-vehicle personnel. In the seminar activities, miners related how radio could have been used to prevent accidents:

- . The snapper expected the train to pull forward, instead of backwards resulting in serious injury to the snapper.
  - . In a rail haulage system, the dispatcher cannot effectively communicate with motormen of battery-powered service vehicles. In one incident, a service vehicle was operating on the main haulageway immediately ahead of a loaded train. The service vehicle motorman was under pressure to clear the main line so that the train could proceed unimpeded to the dump. The
-



motorman entered a turn-out to clear the track; however, he failed to switch the track back so that the train could continue to the dump. The loaded train entered the turn-out slamming into the waiting service vehicle. The service vehicle motorman could have used radio to inform the dispatcher that the service vehicle was on the track immediately ahead of the train. The dispatcher could have slowed the train to enable the timely exit of the service vehicle from the main line. It is a fact that rail traffic safety procedures cannot be implemented without the use of radio links to off-trainmen and motormen of battery powered service vehicles.

- . When a serious accident occurs, a great deal of time is required to inform management and summon help. Many accidents require one to two hours before the injured miner can be removed from the mine. The use of radio will significantly reduce this time.
- . Haulage communications must be restricted to only traffic matters. During a field test, the haulage communications system was used during an operating shift to evaluate voice transmission quality of the new radio equipment. The test transmissions confused the train motormen.

5. The communications technology used in hoist systems is in urgent need of improvement.

In deep shafts, electronic equipments installed in cages are subjected to rapid changes in environmental conditions. High vibrations, rapid changes in temperature and condensation forming inside of enclosures degrades the reliability of the available radio equipment. Antennas coupling the signals to the wire rope are located on the head frame near the sheave wheel. Similar antennas are located on top of the cage. Shaft inspection is performed without the benefit of radio. Maintenance exposes the crew members to excessive risk.

Efficient antennas and couplers are needed. The antenna must be capable of illuminating the wire rope at the collar or in the hoist room. This will permit maintenance to be performed at ground level.

Radio equipment must be specifically designed for this application and include means for reliable electronic signalling.

6. In the event of a mine disaster such as an explosion, cave-in, fire, etc., where miners may be trapped underground, efficient rescue efforts are essential. Rapid and efficient operations not only enhance the possibility of achieving a successful rescue, but also reduce the risk to the rescue team.

Teams equipped with personal radios will revolutionize mine rescue. In practice, rescue teams from surrounding mines cooperate during a disaster. To insure communications compatibility among rescue teams, a common national rescue frequency (400 kHz) will be assigned. To insure that the rescue radio equipment will be properly maintained, the rescue radios will also be used in the maintenance net.

7. Production foremen need to coordinate the underground mining activity.

In coal mining, transportation of supplies must be coordinated with production needs. The foreman needs to communicate with service vehicle motormen to insure timely delivery of supplies. Frequently, the foreman must adjust the production rate to match the belt haulage rate to avoid product spills along the belt line.

In vertical crater retreat (VCR) and blockcaving mining processes, it is necessary to coordinate haulage and mucking operations. These operations occur on different levels of the mine. If the production foreman can be made aware of "full" transfer raises or draw points mucking can be efficiently directed.

As a practical matter, roving mucking and production foremen cannot use the telephones to efficiently coordinate haulage. Use of personal radio is expected to increase haulage by five percent.

The radio productivity multiplier for any mining organization can be determined by considering the above factors. Table A illustrates the expected production improvement in a medium sized coal mine. Line Item B shows the average face production and belt haulage in a typical one million ton per year (1MTPY) mine. The data follows from the actual production statistics (prior 12 mo.). Line Item C shows the downtime cost in tons/hour. In coal and M/NM mining, haulage-way disruption is exceedingly expensive. The expected production increase due to the use of radio is shown in Line Item D data. It is assumed that equipment breakdowns will occur in at least one section during a shift. Product flow along the haulageway will be disrupted. Radio will eliminate the keyman "reach time" (35 minutes) associated with each production disruption.

TABLE A  
PRODUCTIVITY MULTIPLIER  
WORK SHEET

|  | Example    | Mine<br>Forecast |
|--|------------|------------------|
| A. Actual Production Statistics                  |            |                  |
| Annual Production (Tons)                         | 1,000,000  |                  |
| Production Days                                  | 250        |                  |
| Shifts Per Day                                   | 2          |                  |
| Operating Sections                               | 6          |                  |
| B. Production Tonage Per Shift                   |            |                  |
| Each Face  | 333        |                  |
| Haulageway                                       |            |                  |
| Feeder   | 333        |                  |
| Main   | 2,000      |                  |
| C. Down Time Cost Per Hour (Tons/Hour)           |            |                  |
| Face   | 42         |                  |
| Haulageway                                       |            |                  |
| Feeder   | 42         |                  |
| Main   | 250        |                  |
| D. Increase In Production Per Shift (Tons/Shift) |            |                  |
| Reduced Breakdown Time                           |            |                  |
| Face   | 25         |                  |
| Haulage  | 146        |                  |
| Better Coordination                              | <u>100</u> |                  |
| Total  | 271        |                  |
| E. Increase In Production (Per Year)             |            |                  |
|  | 135,500    |                  |

Face and haulage system production rate will increase as shown. Use of radio by supervisors is expected to increase mining efficiency by five percent. The radio productivity multiplier for an empty coal mine significantly increases productivity by 13.5 percent (135,000 ton/year).

The expected return on investment is remarkable. The cost of the radio equipment including maintenance and replacement cost is \$53,900. Assuming a \$35/ton revenue with a 3 percent operating margin, the first year return on investment is

$$\text{ROI} = \frac{\$141,800}{53,900} = 2.63$$

The cost of the equipment can be recovered 2.63 times in one year. The present value (PVi=12%) of the 5 year production increases are

$$(3.91) \times \$141,800 = \$511,900$$

The above productivity and financial analysis are conservative in the sense that safety enhancement expectations were not included. Poor communications is a factor in many accidents. Cost includes damaged equipment, disruption in the mining process, and most of all, the loss of an injured employee's services (minimum cost of \$60,000 per year). It is not unreasonable to expect an even greater ROI.

F. SYSTEM ARCHITECTURE

Following recommendations of Bavelas, cells of radio coverage are created enabling roving miners within a working group to communicate in a party line sense. Every miner within the group receives the same information. Cells are interconnected permitting information flow in the organization. The architecture of the whole mine radio communications system is shown in Figure 4.

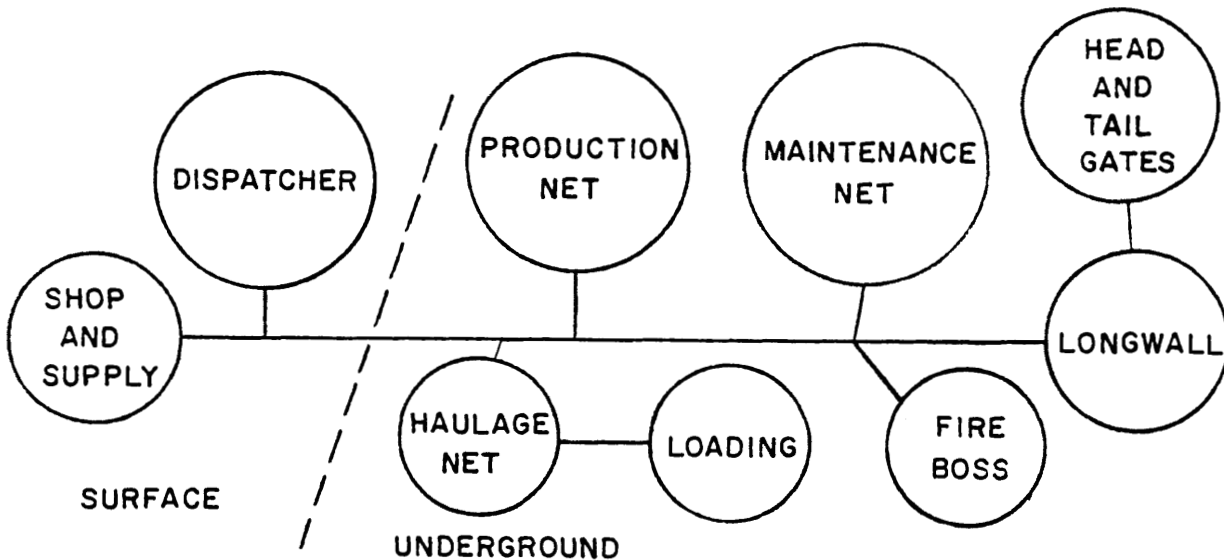

FIGURE 4. SYSTEM ARCHITECTURE

Each cell of radio coverage provides coverage in the working group's area. In the case of the maintenance group, the work area extends throughout the entry drifts and the face area. A communication path extends from the point of equipment breakdown to the surface shop and supply areas. Production coverage includes the work area as well as entry drifts. This enables key production personnel to coordinate haulage of critical supplies and production product (muck, coal, etc.). Haulage coverage includes the loading and dumping areas as well as along the haulageway coverage. Motormen (drivers) can communicate with the dispatcher and off-train men.

In most mines, the maintenance and production nets can be merged into a single net. Production supervisors can communicate with maintenance supervisors.

The cells of radio coverage will overlay each other. Messages in one cell are not heard in other cells. The cells are created by assigning a specific operating frequency to the radio equipment assigned to the working group. A typical operating frequency plan is shown in Table B below.



TABLE B

OVERLAY FREQUENCY PLAN  
MAGMA COPPER COMPANY  
SAN MANUEL DIVISION  
SAN MANUEL, AZ.

| <u>CELL</u>                 | <u>FREQUENCY (kHz)</u> |
|-----------------------------|------------------------|
| Haulage Net (F3)            |                        |
| 2075 Level                  | 165                    |
| 2375 Level                  | 145                    |
| 2600 Level                  | 190                    |
| Loading                     | 460                    |
| Maintenance/Production Net  |                        |
| F1                          | 400                    |
| F2 (Aquisition of Repeater) | 520                    |
| Hoist Net                   |                        |
| Shaft 1                     | 175                    |
| Shaft 2                     | 100                    |
| Shaft 3                     | 160                    |

### III. DESCRIPTION OF THE WHOLE MINE RADIO COMMUNICATIONS SYSTEM

#### A. SUMMARY

The features and principles of operation of the whole mine radio system are described in this section. The system permits underground personnel to maintain communications almost anywhere in the mine, and with the surface complex. As a consequence, in case of a breakdown of mining equipment communication with the location of breakdown is possible. This is a significant feature, in that it improves productivity by reducing down time.

Random inductive coupling into existing mine conductors proves to be desirable and insures extensive coverage. No special communications cable need be installed. Base stations and repeaters can be installed in minutes in locations of prime mine power. Backup batteries are included for additional reliability.

Mobile transceivers consist of vehicular and personnel transceivers. The vehicular transceivers utilize a newly designed antenna of exceptional efficiency and durability. The personnel transceivers utilize a unique vest concept that permits a low profile and affords excellent user convenience.

#### B. INTRODUCTION

The radio coverage cells created by the system in a typical coal mine are illustrated in Figure 5.

MEDIUM FREQUENCY  
WIRELESS COMMUNICATION SYSTEM

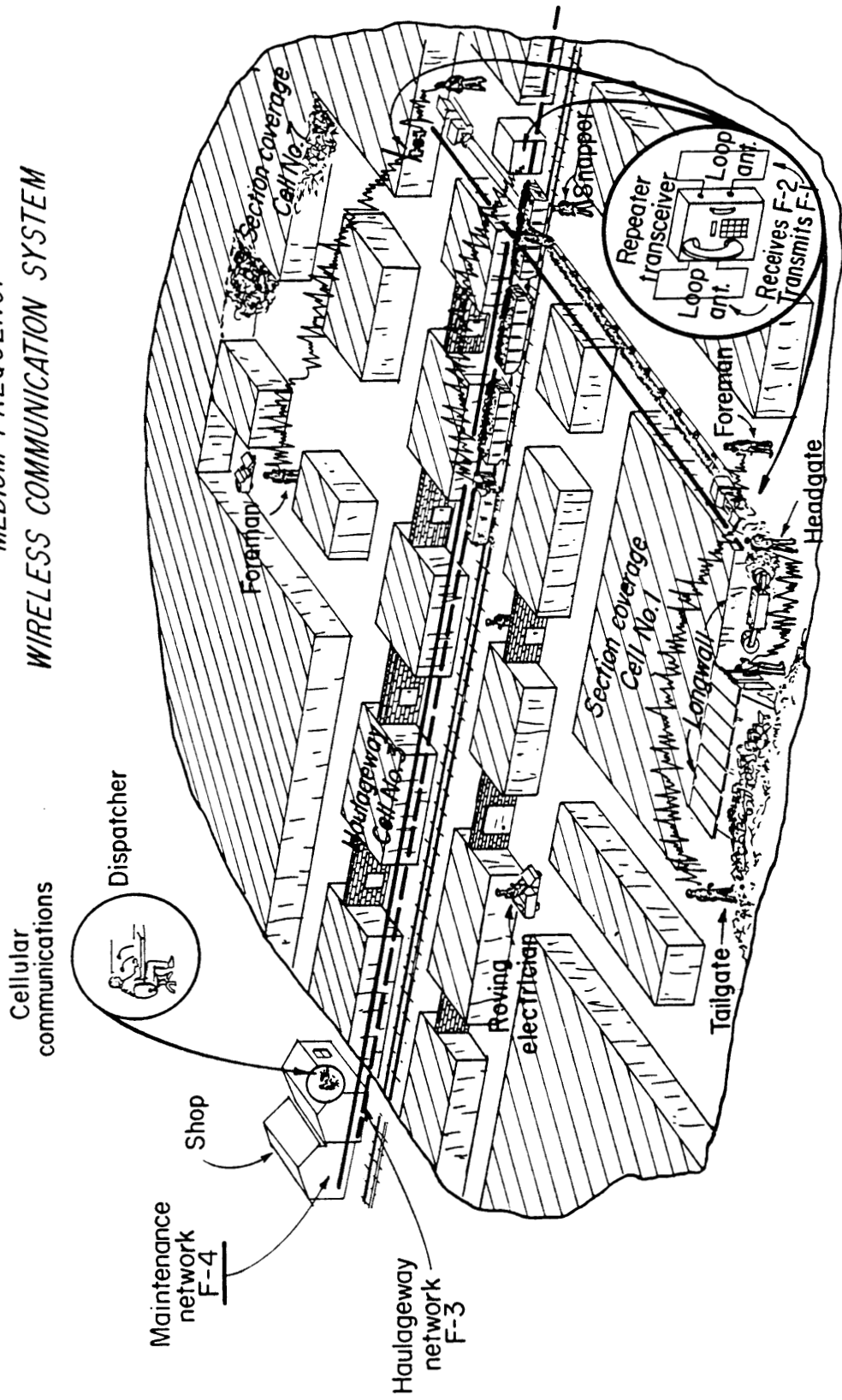

FIGURE 5 RADIO COVERAGE CELLS IN AN UNDERGROUND MINING COMPLEX

The maintenance cell (maintenance network; F-4=400 kHz) extends from the shop throughout the passageways. The haulage cell (haulageway network F-3) covers the entire haulageways and loading/unloading areas.

Roving miners communicate by coupling electromagnetic signals to the existing electrical conductors in the passageways as illustrated in Figure 6.

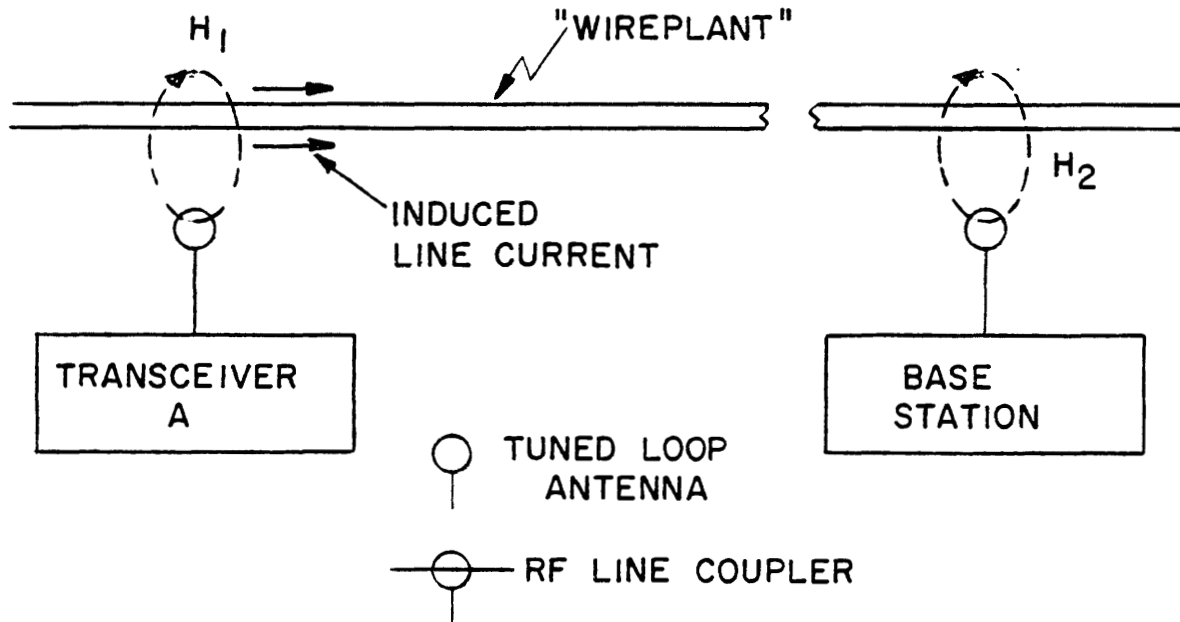

FIGURE 6. THE "NEAR" MAGNETIC FIELD RADIO COMMUNICATIONS SYSTEM

Electrical conductors in the passageways provide a means of distributing radio signals in the mine. Research and field demonstrations have shown that medium frequency (MF) signals (300 kHz to 1.0 MHz) can couple to and from nearby conductors in the mine tunnels. These conductors (called a "wireplant") include electrical power wiring, control lines, telephone cable, metal water and air pipes, and I-beams. Since mines include these electrical conductors, MF signal distribution networks are already in place in most mines in the U. S. The communication range between roving miners is measured in miles.

Signal coupling to the "wireplant" occurs when the tuned loop antenna (transceiver A) produces a "near" magnetic field ( $H_1$ ), signal that illuminates the "wireplant". In effect, the signal magnetically couples to the "wireplant" creating induced line current flow in the electrical conductors. The current flows along the "wireplant" producing a local magnetic field ( $H_2$ ) as it travels (propagates) on the "wireplant". At a distant location, the local field inductively couples the MF signal to the tuned loop antenna associated with transceiver B.

The emf signal produced in the antenna is applied to the input circuit of the "B" transceiver-receiver. Thus, personnel with "near" magnetic field equipment can communicate when in near proximity to the "wireplant".

The use of base stations and repeaters is illustrated in Figure 7. The base station enables the roving miners with mobile transceivers to communicate with the shop or dispatchers office. The global repeater extends the operating range of the system in two ways. First, by transmitting on the frequency (F2), the base is able to acquire the global repeater and reach a distant mobile transceiver. Secondly, by transmitting on the frequency (F2), a mobile transceiver can acquire the repeater and reach a distant mobile transceiver.

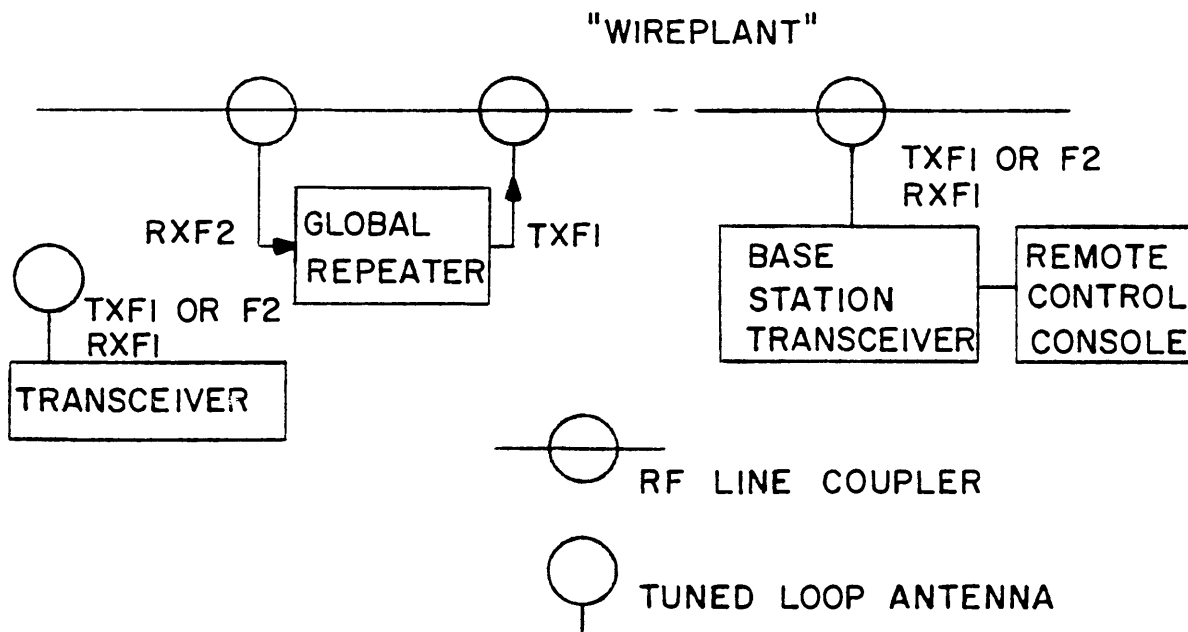

FIGURE 7. USE OF BASE STATION AND REPEATER

The base can be controlled remotely by a single pair of lines. The control console can be placed in a surface building for convenience, while the actual base transceiver is placed in the mine where it can more efficiently couple signals to the "wireplant".

In addition to the tuned loop antenna illustrated in Figures 6 and 7, RF line couplers are used to couple signals to the "wireplant" conductors. Like a current probe, the RF line couplers have been designed to be easily clamped around "wireplant" conductors. The level of line current induced by a coupler is greater than that produced by the illumination of the "wireplant" by an antenna. Couplers increase the operating range by miles.

The system may use repeaters to increase the range between mobile transceivers. The radio coverage cell 7 (Figure 5) is created with the cellular repeater illustrated in Figure 8. It is known as a "cellular repeater" because it illuminates a "cell" or area of the mine, such as a working section only.

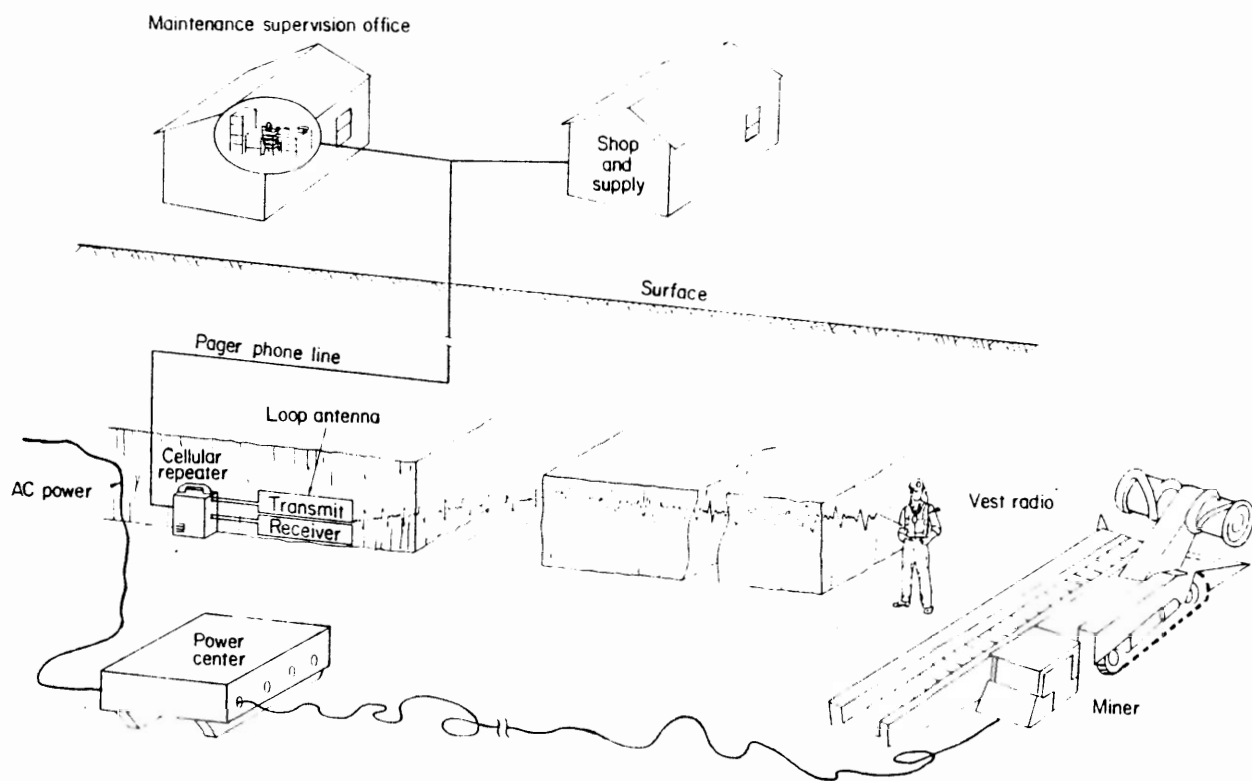

FIGURE 8. RADIO COVERAGE CELL AT THE FACE

The cellular repeaters use dual-loop antennas (for transmitting and receiving) attached to the rib or posts. The "transmitting" antenna produces a large magnetic moment that provides the signal for local cellular coverage, which is usually aided by random inductive coupling effects. The "receiving" antenna is similar.



Wireless signal paths exist between the section repeater and roving miners. Miners (production foremen and maintenance crew) wear vest transceivers in order to communicate with the cellular repeater. Figure 8 illustrates the mobile telephone nature of the working section communications system.

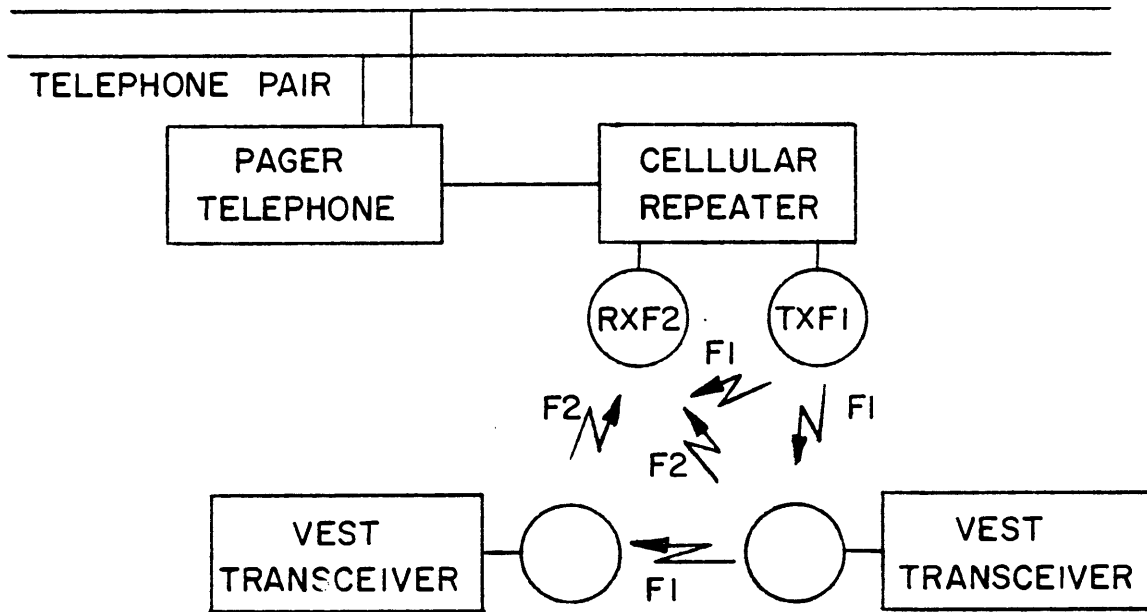

FIGURE 9. F1/F2 SIGNALLING

The cellular repeater is connected to the mine telephone system through the pager telephone. The cellular repeater relays the telephone message to the vest transceiver using the transmission frequency (F1). The vest transceivers are always tuned to receive the frequency (F1). The vest can transmit on (F2) to acquire the cellular repeater and communicate with the host telephone network. The cellular repeater can also operate in the simplex/half duplex mode so that a calling vest transceiver (using F2) can reach a distant vest transceiver in the working area. The vest can create a local mobile-to-mobile network by transmitting on (F1). A distinguishing feature of the cellular repeater is that it uses loop antennas to excite the coal seam propagation mode in the working area. The existence of the coal seam mode was discovered and investigated in U.S.B.M. research (26) (27). This mode exists because the coal seam is bounded above and below by rock (shale) that is significantly more conductive than the coal. In the 300 to 700 kHz frequency range, the signal range reaches a maximum. Field testing in the Kaiser Steel Corp. York Canyon Mine near Raton, New Mexico, showed that voice quality communications could be established between the section power center and the continuous miner (approximately 500 feet ).

## C. MF EQUIPMENT

MF equipment designed for "near" magnetic field communications are shown in the table below:

### Mobile

Vest Transceiver  
Vehicular Transceiver

### Fixed Location

Base Station  
Global Repeater

### Coupling Devices

RF Line Coupler  
Antennas  
Remote Control Console

#### 1. Mobile Transceivers

Two different types of mobile transceivers have been developed for use in the system. Transceivers consist of vest units for individuals and a vehicular units for use in underground vehicles. Functionally the two are identical, differing only in output power levels and physical configuration.

##### a. Vest Transceiver

The vest transceiver has been designed for operation in a gassy atmosphere (CFR, Title 30, Part 23-Telephones and Signalling Devices). The vest transceiver is shown in Figure 10.



FIGURE 10. VEST TRANSCEIVER

The vest transceiver features a set of plug-in modules that are sewn into vest garment along with a loop antenna. An important human factor problem was solved in the vest design. By distributing the bulk and weight of the transceiver over the surface of the vest, the radio becomes an integral part of the user's garment (10). He is free to move in tight quarters and perform normal mining tasks without catching the radio on obstructions. Sound is directed toward the ears from epaulet speakers on each shoulder. A hinged control head is conveniently located on the front.

FIGURE 11. VEST CONTROL HEAD

The vest transceiver can communicate with other mobile units as illustrated in Figure 6. Depressing the push to talk (PTT) switch keys the vest transmitter to produce the carrier signal frequency (F1). By speaking into the microphone, voice message frequency modulate the carrier signal. Depressing the signalling (signal) switch causes modulation of carrier signal with a 1000 Hz audible tone. This can be used for emergency signalling in the event that a miner is unable to speak.



SIG

PAGE



The cellular repeater design includes switching circuitry to allow the vest to operate like a mobile telephone. Depressing the paging (page) switch keys the vest transmitter to the carrier frequency (F2). This signal is modulated with a 100 Hz subaudible tone. The tone signal is decoded in the cellular repeater causing the vest voice signal to be switched onto the host telephone network. Telephone network messages key the repeater to the carrier frequency (F1) for return message transmissions into the radio coverage cell.

The tuned loop antenna is sewn onto the back of the vest. This construction retains the loop firmly keeping its area constant and avoids its detuning during use.

The vest is supplied with nickel-cadmium battery packs. Sufficient capacity is provided in the battery pack for eight hours of normal operation (90% of time in receive and 10% of the time in transmit).

b. Vehicular Transceiver

The vehicular transceiver can be conveniently placed on any mine vehicle. It is used in conjunction with a special loop antenna of advanced design that produces high magnetic moment. Mechanically, the antenna is enclosed in high strength lexan and is attached to the vehicle via special brackets.

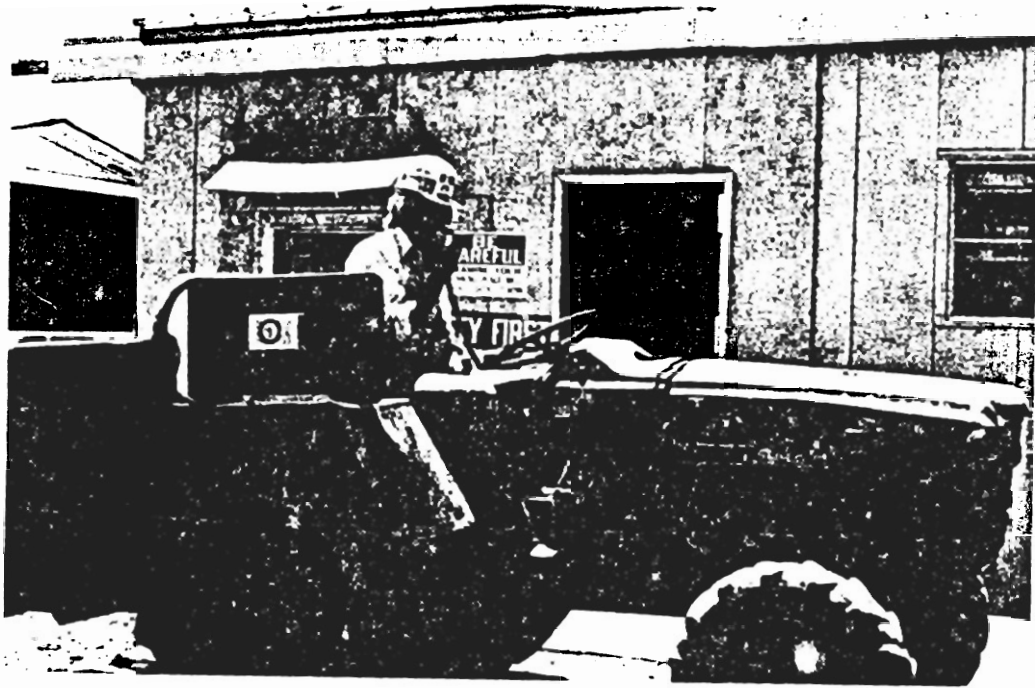

FIGURE 12. VEHICULAR TRANSCEIVER

2. Fixed Location-Repeater

The global and cellular repeaters are identical. They are designed to interface with either RF line couplers or antennas as illustrated in Figures 7 and 8.

FIGURE 13. REPEATER TRANSCEIVER



**MINING  
RESEARCH**  
BUREAU OF MINES

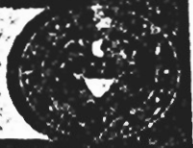

The repeater can stand alone; that is, operate as illustrated in Figure 7. The repeater can also be operated as part of the pager telephone system as shown in Figures 8 and 9. The receiver section of the repeater demodulates the received carrier signals (F2), recovering the F2 message and the 100 Hz subaudible tone. The recovered message signals may be used for two purposes. First, the message signal keys the transmitter section of the repeater producing a high power retransmission signal at the F1 frequency. The message appears as FM modulation on the F1 signal. Secondly, when the subaudible tone is present the repeater decodes the 100 Hz tone and switches the message to the mine telephone network enabling telephone communications.

The repeaters and the base station can be operated from remote control console(s) in the mining complex. Consoles can be located anywhere in the mining complex. A pair of wires connects the console to the repeater as shown in Figure 14.

The repeater design includes filter networks to prevent receiver desensitization.

---

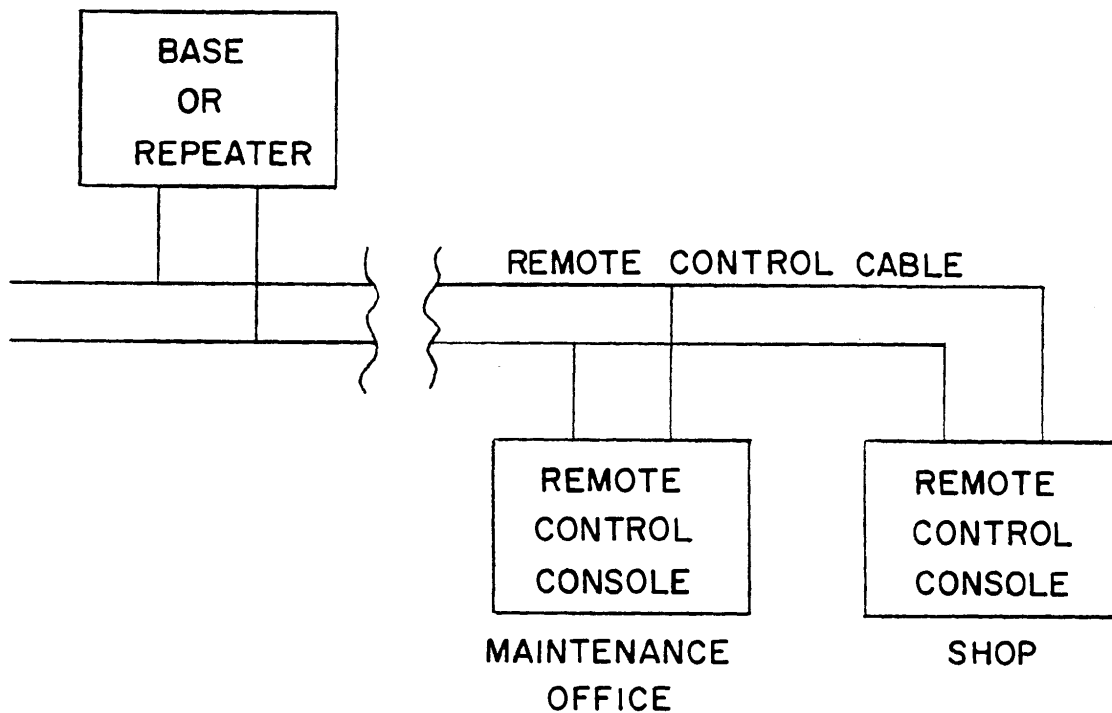
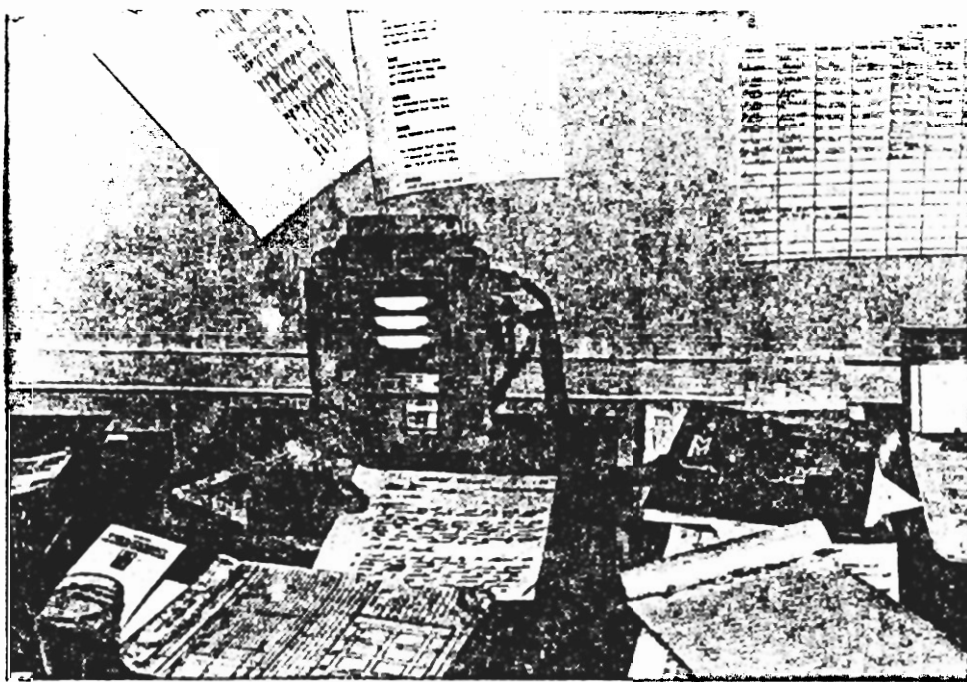

FIGURE 14. REMOTE CONTROL

Multiple Remote Control Consoles (RCC) units base stations and repeaters can be connected to the Remote Control (RC cable (wire pair)). The maximum control signalling distances over the RC cable is 5 miles. The RCC unit is shown in Figure 15.

FIGURE 15. REMOTE CONTROL CONSOLE



### 3. Base Station

The vehicular transceiver is used as the base station in the system. The transceiver is equipped with circuitry to enable base station control with the remote control console.

An AC to DC converter is used to maintain the standby batteries in the base.

### 4. Coupling Devices

The coupling devices used in the system include RF line couplers, and tuned loop antennas.

#### a. RF Line Coupler

The global repeater and base station are designed to drive and receive signals from RF line couplers. Like a current probe, the coupler can be easily clamped around local conductors.

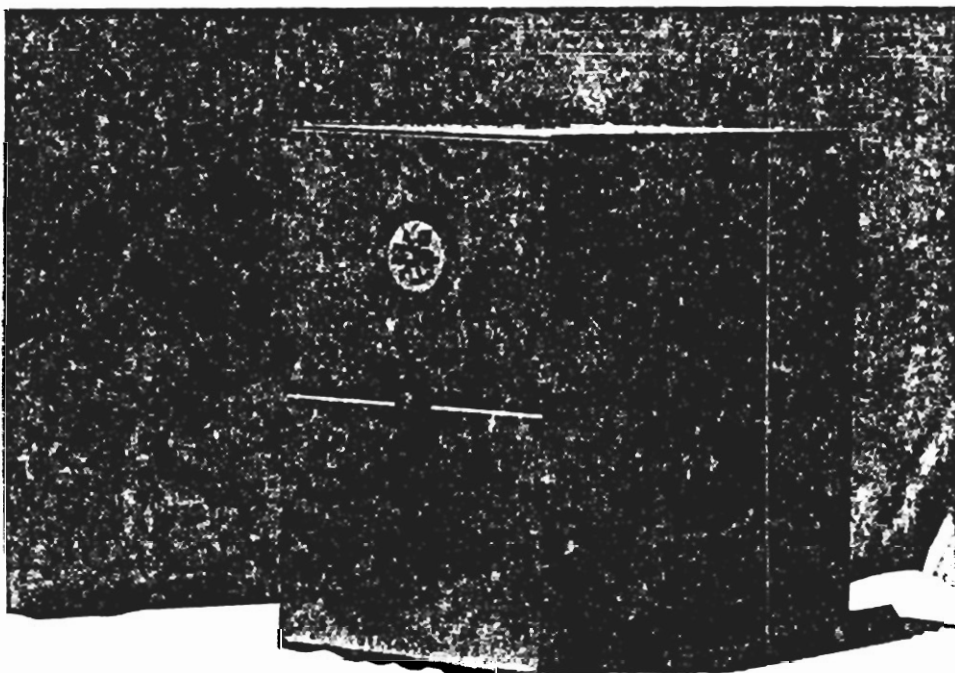

FIGURE 16. RF LINE COUPLER

b. Antenna

The cellular repeater and vehicular transceiver use tuned loop antennas to illuminate the work area or to induce current flow in nearby electrical conductors.

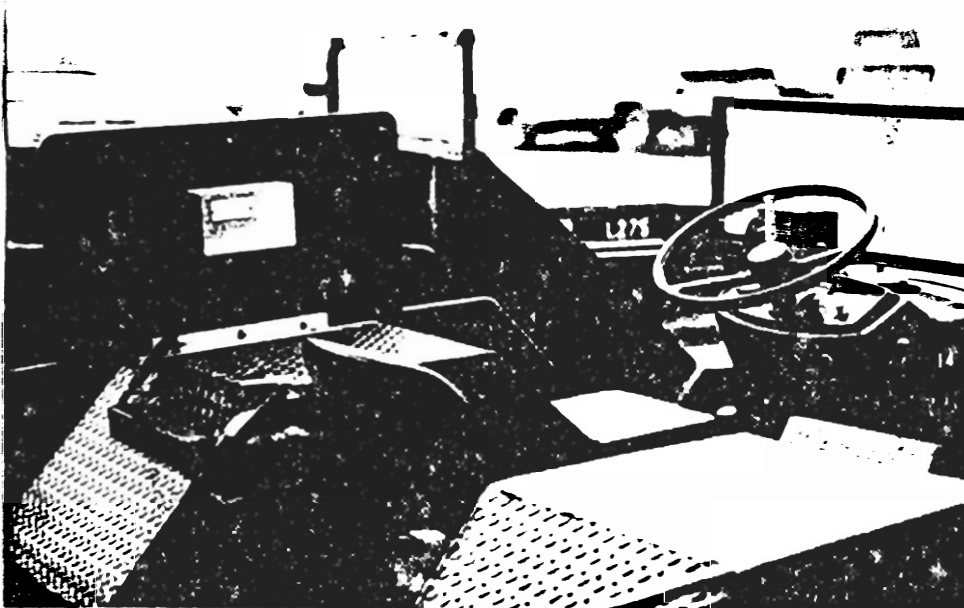

FIGURE 17. TUNED LOOP ANTENNA

The antenna may be mounted on a vertical or horizontal mounting surface.

#### D. FIELD MAINTENANCE

The radio equipment is designed around a standard set of interchangeable plug-in circuit modules. The standard receiver, synthesizer, exciter and transmitter modules are used in the vehicular transceiver, base station and repeaters. The vest transceiver modules have been designed exclusively for use in the hazardous atmosphere per Underwriters Laboratory Document UL913 (MSHA requirements). The vest modules perform similar functions to standard modules; however, the actual design is substantially different. Maintenance requires troubleshooting to the module level. Module servicing is strictly prohibited other than by factory certified electrical technicians. Since the equipment uses similar performing modules, the specifications of all transceivers are identical.

The modular design insures that the equipment can be maintained in the field at minimum cost. Servicing only requires troubleshooting to the module level.

## E. INSTALLATION

The MF radio communications system features maximum installation versatility as well as simplicity and reliability in actual operation. The system has been successfully installed and demonstrated in four underground mines. The mines, identified in Table C , were selected because they are representative of mining process in common use in the U.S. mining industry. In the course of the installation work, a wide spectrum of problems were encountered and solved. Lessons learned in the successful installations have been developed into a planning guide that can be followed by a mining company wishing to take advantage of radio in mining. The planning guide is illustrated in Figure 18.



TABLE C  
COOPERATING MINES

ORGANIZATION

Magma Copper Company  
San Manuel Division  
San Manuel, AZ

Ranchers Exploration & Development  
Revco Silver Mine  
Interprise, Utah

Kaiser Steel Corporation  
York Canyon Mine  
Raton, New Mexico

Getty Oil Company  
Plateau Mining Company  
Price, Utah

MINING PROCESS

Block Caving

Vertical Crater  
Retreat

Conventional and  
Longwall

Coventional

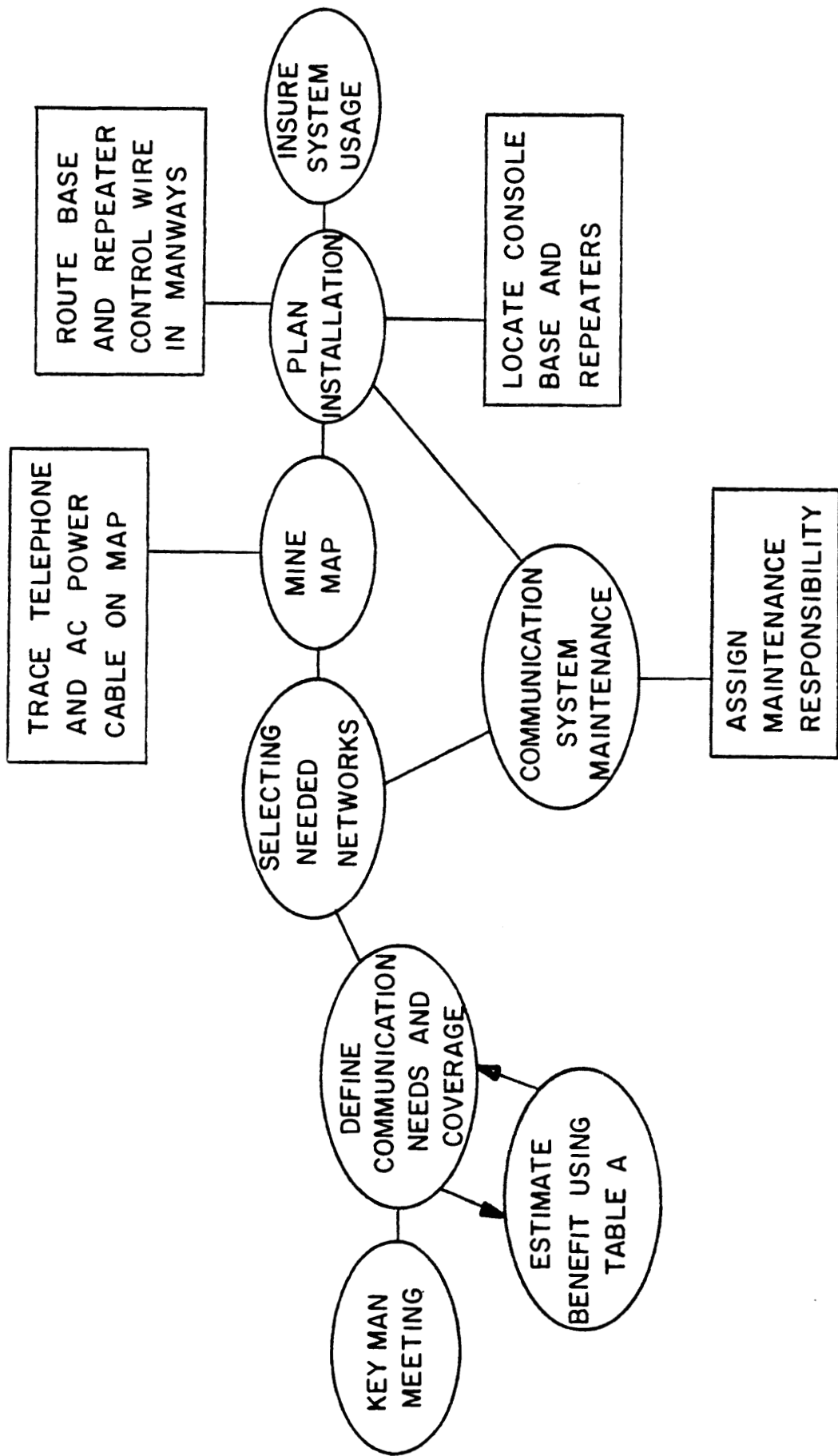

FIGURE 18 SYSTEM PLANNING GUIDE

## 1. Keyman Meeting

Planning the communications system in advance of the installation is important in several respects. First, the primary goal is to involve management and other keymen, at the earliest possible time, in the planning process. Keymen must be familiar with the principal and operating features so that they may accurately define the required radio coverage areas. The material presented in Chapter III (Section B) can be used to acquaint keymen with the system concept. Secondly, planning insures that the communications system will contribute to team work and improve efficiency in the mining process.

## 2. Define Communication Needs and Coverage

Keymen must communicate to insure a smooth running mine. Communications must be provided in all work areas, and frequently traveled passageways. The needs can be determined by considering the following questions:

- . Which keymen must communicate (net together)?
- . How will they communicate (from vehicles or on foot)?
- . What kind of communications problems must be solved with radio?
- . How can the system be used to reduce mining cost?

The latter can be evaluated by using a benefit analysis similar to that presented in Table A . Line items to be considered can be expanded to include other specific tasks. For example, the cost of loading or drawing muck without using radio can be determined. The train loading process frequently employs light signalling to command the motorman to move the train (two blinks of a light to move forward, etc.). Radio will enable more exact train movement, thus minimizing loading time.

The benefit analysis is useful as a guide in designing the communications system in the near and far term. In the near term, equipment can be installed to realize the greatest improvement in productivity expected in the benefit analysis. At a later date, additional equipment may be added to realize lesser improvements in productivity.

The MF system provides natural radio coverage near "wireplant" conductors. If a frequently traveled passageway is "free" of electrical conductors, a low cost two-wire cable must be installed to provide reliable radio coverage in these areas.

In M/NM and coal mines, the operating range from the base station is dependent upon the type of electrical conductors in the "wireplant". Telephone cable provides the lowest signal propagation loss (4 dB/1000) and range along the cable will exceed 20,000 feet. AC power cables also

provide excellent coverage; however, each power transformer along the cable absorbs signal energy. Each power transformer decreases the range by approximately 2000 feet. Bearing in mind, that if AC switches are encountered along the AC power cable, an open switch will dramatically reduce operating range. In coal, MF signals can be received almost everywhere in the mine; however, the talk-back range may be limited to the same entry with the "wireplant" or at most an adjacent entry.

### 3. Selecting Needed Networks

The following networks should be considered for use in a mine:

Supervision Network,  
Maintenance Network,  
Production Network,  
Haulage Networks, and  
Hoist Systems Network.

The use of radio will relieve the existing telephone system of most of the critical message traffic. In most mines, some of the networks will merge together. For example, the maintenance and production networks can be operated as a single network to improve team work. The "nerve" centers for this network are the shop, warehouse, and supervision (production and maintenance) offices. A remote control console(s) should be installed in each critical location.

In very large mines, a separate supervision network may be considered for the transmission of sensitive information (union labor matters, etc.). However, in most mines, the direct dial telephone system serves this communication need.

A separate network is mandatory for serving the communication needs in a rail haulage system. Vehicular transceivers must be assigned to all rail service vehicles. Vest radios must be assigned to all off-train men (loader, snapper, chute tappers, etc.). In small mines, the systems are most efficiently self-dispatched. The "nerve" centers are usually the shop, and the production superintendents office. In larger mines, the dispatchers office is the communications "nerve" center for the haulage and maintenance networks. In belt haulage systems, beltmen must be assigned vest transceivers to communicate in the maintenance network.

It is necessary to install vehicular transceivers on all service and "keyman" vehicles. If the "keyman" is frequently on foot during the course of his work, a vest transceiver must be assigned.

Since MF signals propagate so well in a mine, MF will revolutionize mine rescue and provide emergency communications to trapped miners. The maintenance network will be used in emergency situations. Underground ambulances should be equipped with a vehicular transceiver and communicate in the maintenance network (400 kHz).

The amount of radio equipment recommended for use in the networks depends upon the size of the mine. Table D describes the equipment used in maintenance and production networks in a medium sized coal mine.

TABLE D  
TYPICAL  
EQUIPMENT LIST  
(1MTPY COAL MINE)

NETWORK

|                        | B <sup>(3)</sup> | VST | VEH <sup>(2)</sup> | CR <sup>(2)</sup> | GR <sup>(3)</sup> |
|------------------------|------------------|-----|--------------------|-------------------|-------------------|
| Maintenance/Production | 1                |     |                    | 4                 | 2                 |
| Foreman                |                  |     | 3                  |                   |                   |
| Roving Mechanic        |                  | 1   |                    |                   |                   |
| Roving Electrician     |                  | 1   |                    |                   |                   |
| Fire Boss              |                  | 1   |                    |                   |                   |
| Service Vehicle        |                  |     | 7                  |                   |                   |
| Longwall Crew          |                  |     |                    | 1                 |                   |
| Mechanic               |                  | 1   |                    |                   |                   |
| Head Gate              |                  | 1   |                    |                   |                   |
| Shear Operator         |                  | 1   |                    |                   |                   |
| Train Gate             |                  | 1   |                    |                   |                   |
| Chockmen               |                  | 2   |                    |                   |                   |
| Haulageway             | 1                |     |                    |                   |                   |
| Belt                   |                  |     |                    |                   |                   |
| Beltmen                |                  | 4   |                    |                   |                   |
| Rail                   |                  |     |                    |                   |                   |
| Motormen               |                  |     | 7                  |                   |                   |
| Off Train Men          |                  | 4   |                    |                   |                   |
| Service                |                  |     | 7                  |                   |                   |
| Total                  | 2                | 17  | 24                 | 5                 | 2                 |

B - Base Station  
VST - Vest Transceiver

CR - Cellular Repeater  
GR - Global Repeater

(1) Bar symbol indicates recommended equipment quantity in an 1MTPY coal mine using belt haulage and conventional mining techniques. (2) Requires vehicular antenna(s). (3) Requires RF line coupler(s).



#### 4. Mine Map

The mine map is the key installation document. Use the map to lay out the needed cells of radio coverage. Include on the map the telephone and AC power cable entries. Bear in mind, that coverage along the AC power cable will depend upon the number of installed power transformers. Radio coverage reliability will depend upon AC switch locations.

The base station(s) and repeater(s) can be located on the map. The base station should be located at the portal or the mid-point of the "wireplant" in larger mines. It must be located near 117 V AC power to enable charging of the standby batteries in the base. The operating range along telephone cable is typically 20,000 feet from the base. Along AC power cable the range is reduced by 2,000 feet for each transformer along the cable. Additional base stations can be installed to increase radio coverage to mobile transceivers. Single or multiple base stations in the network can be controlled from the remote control console(s) located in the mine "nerve" centers.

As shown in Figure 7, the repeater has the advantage over the base in increasing operating range between mobile transceivers. This requires that the mobile transceivers operate in the F1/F2 signalling mode. This is contrasted to only the F1 signalling required if multiple base stations are used to extend the base to mobile transceiver operating range along the "wireplant".

Cellular repeaters should be used to illuminate the face if "wireplant" is not available in the area.

#### 5. Installation Plan

The installation plan follows from the work done in Section 3.

The most remarkable feature about the system is the versatility of installation as well as the simplicity of operation. Almost every communication problem can be solved by simply installing the required equipment in the network.

For those mines wishing a demonstration of the radio coverage capability, the required equipment can be installed in minutes. Cells of radio coverage include entries with existing "wireplant". Permanent installations can be made without disruption in the mining process.

The RF line coupler and base station are installed as illustrated in Figure 19.

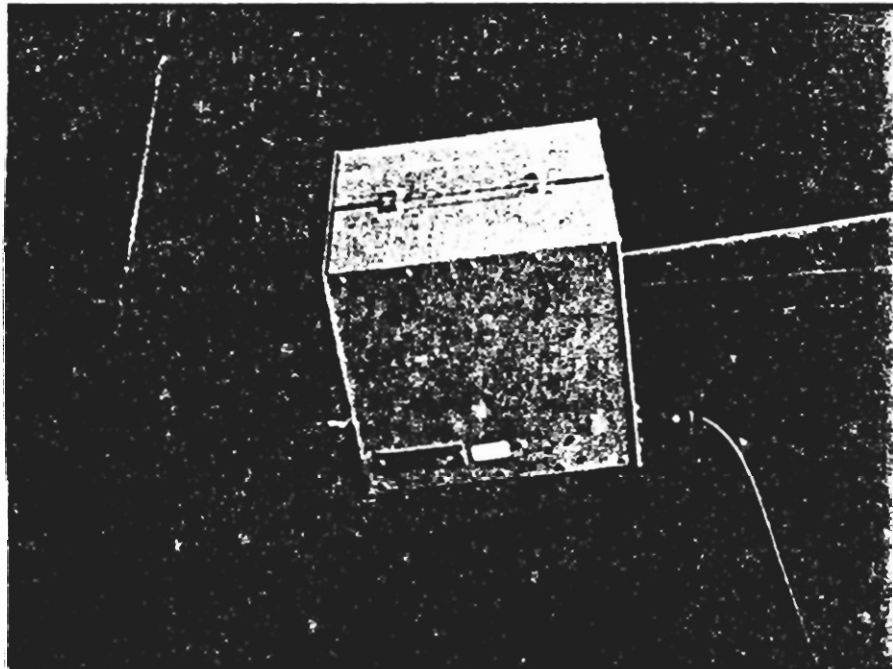

FIGURE 19. RF LINE COUPLER INSTALLATION

The coupler is simply clamped around every conductor in the "wireplant". The installation is completed by connecting the coupler to the base station.

The Remote Control Console (RCC) unit(s) is located in the "nerve" center(s) for the communications network (shop, warehouse, etc.). RCC unit(s) is connected to the base station by Remote Control (RC) cable (single pair of wires). In most installations, a telephone pair has been used as RC cable.

In manway entries without electrical conductors, a low cost twin-lead cable must be installed. The installation of the cable is diagramed in Figure 20.

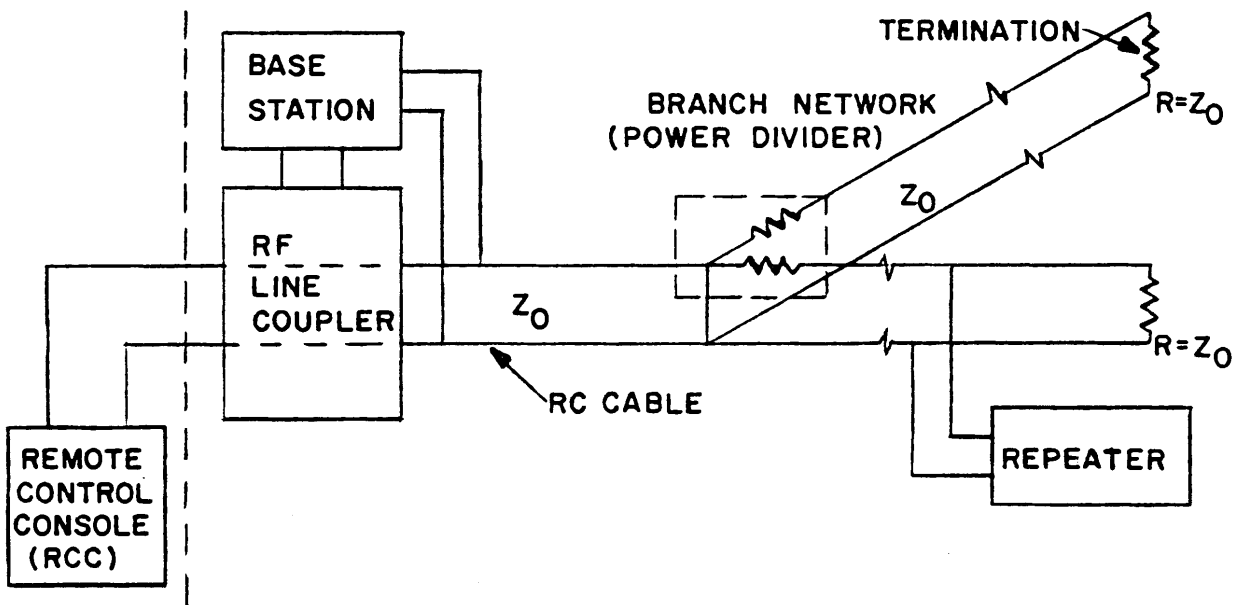

FIGURE 20. BASE STATION AND REPEATER CONTROL CABLE INSTALLATION DIAGRAM

The RC cable is installed like a pager telephone wire pair. The cable carries DC commands, signalling tones and voice signals to and from the RCC unit(s). By threading the RF line coupler with the RC cable (as illustrated in Figure 20), the RC cable also serves to improve MF radio coverage in manways. Branch lines needed to extend radio coverage in manways are connected through passive power dividers. The branch lines are always terminated in the line characteristic impedance ( $Z_0$ ). This has several advantages, first, because the RC cable is properly branched and terminated, the standing waves caused by impedance mismatch conditions along the lines are minimized. Communication "dead spots" in the passageway are eliminated. Secondly, the RC cable extending from the mine portal to the surface "nerve" centers provide a communication means when the mobile transceivers are out of the mine.

Radio coverage is greatly increased in practice by MF signal coupling between cables. Cables that route through the same drifts are magnetically coupled. MF signal current flow in one cable induces current flow in the other.

Certain installation precautions must be observed in the installation of the equipment:

- . The installation of an RF line coupler on telephone or AC power cables must observe specific high voltage insulation precautions. The coupler name plate must show adequate dielectric withstanding voltage (DWV) rating. If the name plate rating is inadequate, esophagus tubing with sufficient dielectric withstanding voltage rating may be placed over the cable before installation of the RF line coupler.
- . In coal, roving miners that go inby must use permissible vests.
- . Transceivers and repeaters used in the mine must be grounded to the vehicle frame ground or the mine safety ground system. Transceivers that are installed on vehicles that operate from high voltage batteries or trolley cable must be grounded to the vehicle frame ground. This requires the mandatory use of DC to DC converters with sufficient DC input to convert DC output isolation.

Transceivers that are installed on vehicles that operate from floating (ungrounded) batteries must be grounded to the vehicle frame ground. This requires the mandatory use of DC to DC converters with sufficient DC to DC input to output isolation.

## 6. Insuring System Usage

Once the system is installed and checked out, management must insure that it increases centrality. They should assist in training keymen to use the radio system effectively.

Bear in mind that miners are accustomed to working independently. They will prefer to keep it that way. Management must require in and out shift meetings of all keymen to coordinate the mining activity. Radio should be used to assist the keymen and their crews in their assigned task.

The radio system reliability will depend upon adequate maintenance. The mines shown in Table C have excellent maintenance policies and personnel. At the beginning of the system planning in each of the mines, radio maintenance responsibility was assigned to one maintenance crew member. He was trained to troubleshoot the system equipment to the board level.

In all of the mines, the trained maintenance personnel were able to adequately maintain the radio system. As a back up contractor's personnel were made available to assist the maintenance crew member by telephone.

Since the system uses plug-in modules, they required only two sets of plug-in boards for the transceivers and repeaters are maintained at the mine site.

It is important to insure good radio maintenance policies. Crawley (30) of the U.S.B.M. has studied the five year performance of a leaky feeder communications system in the U.S. mining industry. After five years only one system remained in an operational condition. System failures were partly caused by the difficulty of maintaining coaxial cable in an operating mine.

Lack of interest and effectiveness of the maintenance crew was also a strong factor in the failure of the radio equipment.

RADIO EQUIPMENT SHOULD NOT BE INSTALLED IN MINES THAT HAVE POOR MAINTENANCE POLICIES.

#### IV. THE SYSTEM DESIGN

##### A. SUMMARY

The operating range of a medium frequency (MF) underground communications system is dependent upon many technical factors, including the characteristics of the noise generated in electrical power systems, signal propagation modes, selection of the optimum modulation-demodulation process, the efficiency of the couplers and the susceptibility of the receiver to desensitization by impulsive mine noise.

Considerations of the many factors provide additional insight into the expected system performance and a conclusion that narrow-band FM is the preferable modulation process.

##### B. INTRODUCTION

This chapter deals with theoretical methods used in the design of the underground radio communications system. Some of the problems which arise in the design of this system are, in many cases, similar to those encountered in surface radio systems. Therefore, solutions to these problems follow from a vast body of telecommunications knowledge developed over the past few years. Others require new thinking.



Today's advanced radio communication technology is largely based upon the propagation of radiated field wave signals that travel great distances through atmospheric constituents. While it is true that these signals provide reliable communications over free space paths, waves encountering a contrasting medium are subjected to change in the wave propagation constant causing reflection, diffraction, and absorption of the signal energy. The subterranean environment is extremely hostile to these signals. It is found that the signals from VHF and UHF handheld transceivers are severely attenuated when passing near rail haulage equipment, around corners or through ventilation barricades in the mine. As a result, communications fail (go below threshold) exactly where quality voice communications are needed the most. "Leaky" transmission lines excited by high power transmitters improve tunnel communications; however, old problems persist and new problems have emerged. Communications through ventilation barricades and to the point of equipment breakdown were still not reliable. Further, the practicability of installing coaxial cable in the working area of the mine seems questionable.

### C. HISTORY

Every since the emergence of radio for practical terrestrial radio communications, attempts have been made to apply it to underground mining. As early as 1922, U.S.B.M. experiments showed that radio propagation in mines was possible but not practical.

Equipment was bulky and insensitive, and only very large antennas could be used. By 1948 the Chambers of Mines of South Africa had programs in place to develop radio systems for deep mines, primarily gold mines (19). The result was that by 1973, advanced 1 Watt single sideband (SSB) portable radios were in use (17). The U.S.B.M. procured several of these units for evaluation. Performance in U.S. coal mines was not satisfactory. There were several reasons for this. First, U.S. mines are highly electrified, producing considerable electromagnetic interference (EMI) not normally found in the South African mines, which completely desensitized SSB radios. Second, the power of 1 Watt proved insufficient. U.S. mines are mostly composed of rooms and pillars which means that any radio system would have to have reasonable range from local conductors. Third, geological electrical parameters were less favorable in the United States. For these reasons, the South African system was not acceptable in the United States.

The Bureau's approach was to first determine the actual propagation characteristics of MF in U.S. mines, and then to relate the propagation to the underground environment such as the geology, entry size, existing conductors, and EMI. Several exhaustive in-mine measurement and analysis programs were conducted (20) (21). These programs formed the foundation for the first true understanding of how MF propagates in mines.

Theoretical and experimental work monitored by Sacks and Chufo (12) of U.S.B.M. have shown that MF "near" magnetic field signals propagate through natural media (water, rock, coal, etc.) and great distances down passageways in the underground mining complex. Emslie and Lagace (13) (14) established that a loop antenna would excite a coal seam mode enabling the propagation of MF signals through a coal seam. The cellular coverage in a typical working section is shown in Figure 8.

The work of Hill and Wait (15) considered the excitation of monofilar and bifilar propagation modes on a transmission line in a passageway. Low loss transmission line propagation modes were discovered leading to the passageway coverage shown in Figure 6.

Whole mine radio signal transmission and distribution depends upon the modal excitations described above. One of the advantages of MF "near" magnetic field signals over VHF/UHF planar wave signals is that MF "near" magnetic field signals are not subjected to extremely high path loss when passing near mining equipment, through ventilation barricades and around corners. This is especially important when communicating in a long wall section or repairing mining equipment at the point of equipment breakdown.

The operating range of an underground radio communication system depends upon many factors including:

- antenna magnetic moment (transmitted output power),
- characteristics of electrical noise generated in the mine electrical system,
- the signal propagation mechanism (modes),
- carrier signal coupling efficiency,
- the system modulation-demodulation processes, and
- susceptibility of the receiver to desensitization by electrical noise and other interfering/jamming signals.

In a "near" magnetic field communication system, operating range is a strong function of the signal propagation mechanism and medium, and antenna coupling efficiency between other antennas and transmission lines in the signal distribution system. These factors have been extensively studied in the context of the subterranean communication problem (14) as well as in the related terrestrial communication literature. With respect to these factors, range optimization procedures are well known.

#### D. NOISE GENERATED IN MINE POWER SYSTEM

In the highly mechanized U.S. mining industry, radio frequency interference (RFI) generated in the mine electrical system is a dominating factor in the design of the communication system. A review of the measured noise data (16) (17) reveals that the noise field strength varies over an enormous range (by several orders of magnitude - 60 to 100 dB variation). The noise is greatest near AC to DC converters (rectifiers) and along the trolley conductor in a rail haulage system. Away from the haulageways, the electrical noise level is as much as 40 to 50 dB below the haulageway level. The noise level also changes over a large range during a typical working shift. The magnitude of the noise spectrum decreases rapidly with frequency. For frequencies below 50 kHz its magnitude increases with decreasing frequency at an average rate of approximately 14 dB per octave. Above 100 kHz, the noise density decreases at the rate of 6 dB per octave.

The high noise level influences the design of the RF section in the communications receiver. The receiver design is somewhat more critical than the transmitter design, mainly because of the presence of interfering signals before the signal processing stage. The RF section must discriminate against the noise as much as possible and then amplify the modulated signal and noise in a linear way before converting the signal and noise to the proper intermediate frequency (IF) and subsequent signal processing.

## E. SIGNAL PROPAGATION MODES

The coal seam and transmission line signal propagation modes were evaluated in a series of underground mine tests conducted by the U.S.B.M. researchers. Cory's (21) (22) test results indicated the coal seam mode enabled maximum communication range for operating frequency in the 400 to 700 kHz band (MF band - 300 to 3000 kHz). Further, as predicted by Hill and Wait (15), Cory found the propagation loss on the "wireplant" to decrease with decreases in operation frequency.

### 1. Seam Mode Propagation Theory

The theory of electromagnetic wave propagation in stratified media has been rigorously developed by Wait (23). Electromagnetic waves can propagate laterally via highly resistive layers in the earth (25). Wait (24) has analyzed the case of the coal seam using the simplified model shown below.

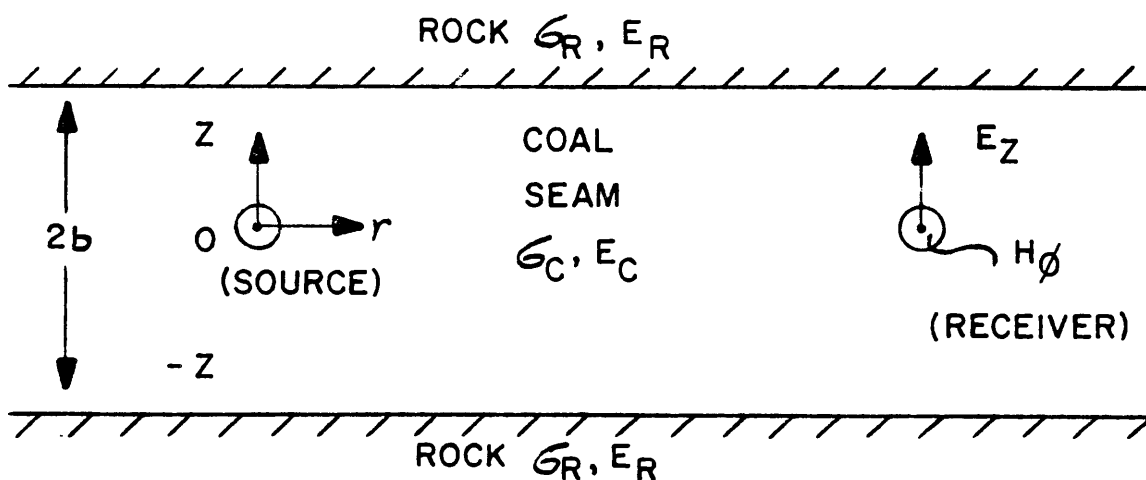

FIGURE 21. SEAM MODE FIELD COMPONENTS

The coal seam is bounded by two conducting half spaces with the conductivity of the rock ( $\delta_r$ ) greater than the conductivity of coal ( $\delta_c$ ). The conductivity of the coal is several orders of magnitude less than the conductivity of the rock. The vertical orientation of the transmitting loop antenna (source) produces, along the transmission path ( $r$ ), a horizontal magnetic field  $H_\phi$  and a vertical electrical field  $E_z$ . The fields are almost constant over the height of the coal seam.<sup>(1)</sup> Emslie and Lagace (26) have shown that the fields die off exponentially in the rock.<sup>(2)</sup> At large radial distances ( $r$ ) from the antenna, the fields decay exponentially at a rate determined by an effective attenuation constant which depends on losses both in the coal and in the rock and on the dielectric constant of the coal. There is also a  $1/r^{1/2}$  factor at large radial distances due to cylindrical spreading of the wave. The zero-order TEM magnetic field  $H_\phi$  in the plane of the transmitting loop is given by:

(1) With perfectly conducting boundaries, when  $\delta_r$  is finite, the zero-order mode field varies with  $z$ ,  $\phi$ , and  $r$  owing to wave propagation across the boundaries.

(2) Skin depth in rock is 0.69 meter,  $\delta_r = 1$  mho, 520 kHz.

$$H_{\phi} = (iMk^2/8 b_e) H_1^{(2)'}(kr) \quad (1)$$

where  $M$  is the magnetic moment of the transmitting loop antenna,

$b_e = b + 1/2 \delta_r$  is the effective half-height of the coal seam. (1)

$\delta_r = z$  direction skin depth in the rock.

$k=B$  it is the complex propagation constant in the radial direction, and

$H_1^{(2)'}(kr)$  = derivative of the first-order Hankel Function for an outgoing wave.

(1) Wait has noted the  $b_e$  may be complex.



On taking the asymptotic form of the Hankel Function, the azimuthal component of magnetic field <sup>(1)</sup> is

$$|H_{\phi}| = \frac{M(\alpha^2 + \beta^2)^{3/4}}{(8\pi)^{1/2} [(h + \delta_r)^2 + \delta_r^2]^{1/2}} \frac{e^{-\alpha r}}{\sqrt{r}} \quad (2)$$

The attenuation and phase constants are given by Emslie and Lagace (26) are

$$\alpha = \left\{ \left(\frac{1}{2}\right) [(p^2 + q^2)^{1/2} + p] \right\}^{1/2} \text{ and} \quad (3)$$

$$\beta = \left\{ \left(\frac{1}{2}\right) [(p^2 + q^2)^{1/2} - p] \right\}^{1/2} \quad (4)$$

where

$$p = \frac{2(\delta_c - 2\pi f \epsilon_c)}{b} \left( \frac{\pi \mu_0 f}{\delta_r} \right)^{1/2} - 4\pi^2 f^2 \mu_0 \epsilon_c, \text{ and} \quad (5)$$

$$q = \frac{2(\delta_c + 2\pi f \epsilon_c)}{b} \left( \frac{\pi \mu_0 f}{\delta_r} \right)^{1/2} + 2\pi f^2 \mu_0 \delta_c. \quad (6)$$

(1) Valid at ranges  $kr < 1$

The zero-order TEM wave described by Equation (1) has been compared with experimental measurements by Cory (27). Emslie and Lagace have determined that the measured results are in close agreement with Equation (1). The attenuation rate in coal is approximately 4 dB/100 feet ( $\delta_c = 1.4 \times 10^{-4}$  MHO/m,  $\epsilon_c = 7$ ,  $\delta_r = 1$  MHO/m,  $b = 1$  m, 350 KHZ).

Equations (3) (5) and (6) are useful in determining the dependence of wave propagation constant on seam parameters. The attenuation rate is expected to increase as the coal seam thickness decreases and conductivity increases. The attenuation rate decreases as the rock conductivity increases. The rate also depends upon frequency.

## 2. Transmission Line Propagation Modes

Theoretical research and actual field results confirm that two signal propagation modes exist on a pair of wires in the "wireplant". The modal current flows are shown below

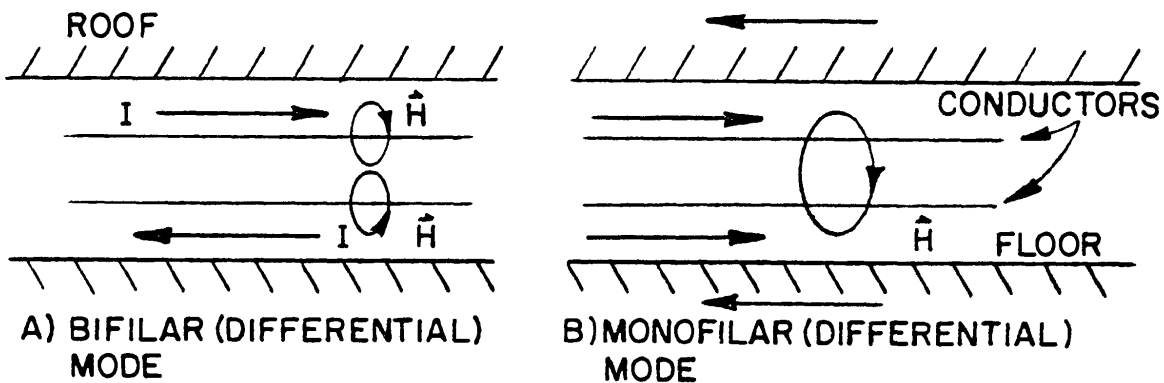

FIGURE 22. SIGNAL CURRENT ( $I$ ) FLOW ON CONDUCTORS ( $n=2$ )<sup>1</sup>

Footnote: The number of possible modes is  $n-1$  where  $n$  is the number of electrical conductors in the wireplant.

Hill and Wait (15) have examined the excitation of monofilar and bifilar modes on a transmission line in a tunnel. In the monofilar mode (also called the balanced, differential, coaxial, or symmetrical mode) current flows in the same direction on both conductors and returns as surface current in the mine tunnel. This mode is readily excited by magnetic coupling from a loop antenna anywhere in the mine tunnel but suffers high attenuation because the return current flows in the lossy tunnel wall. In the bifilar mode (also called the unbalanced, asymmetrical or differential mode), the forward current in the upper conductor returns through the lower conductor. This transmission line mode has low attenuation because the return current flows on the second wire rather than through the surrounding rock. Excitation of this mode depends upon magnetic flux threading the area between the transmission line conductors. Mode conversion naturally occurs on a two-wire transmission line because of random imperfections in the "wireplant" and mine tunnels. Non-uniformities in tunnel cross section, sag in cable with respect to the roof and incidental changes in the spacing between conductors cause the characteristic impedance ( $Z_0$ ) of the cable to change along the line. Changes in the line characteristic impedance cause radiation and reflection of the signal energy. As a result, monofilar and bifilar mode interchange conversions occur all along a line. Researchers in Belgium were the first to develop mode converters to transform monofilar mode to bi-

fililar mode signals (33) (34). The Belgium converters were realized by a series of inductances inserted in one line and a capacitances in the other.

Two-wire cable that is added to the "wireplant" to increase radio coverage in manways without "wireplant" should be designed to take full advantage of efficient monofilar mode coupling and bifilar mode low attenuation rate. Untwisted-pair cable should be used because fields from twisted pair cable are reduced by 50 dB at a distance  $R = 1.5 p$  from the cable where  $p$  is the pitch of the twisted pair (35).

#### F. COUPLING MF SIGNALS TO THE "WIREPLANT"

The coupling of signals between transmitting loop antennas and the "wireplant" will be examined in this section. The equations define bifilar mode coupling to cables in free space. Monofilar coupling also occurs; however, monofilar signal level depends upon the tunnel surface impedance. The nature of this coupling was previously examined by Hill and Wait (15).

##### 1. Transmitting Loop Antenna and Two-Wire Transmission Line Coupling

Theoretical equations that relate to the bifilar current signal level induced in a "wireplant" transmission line to the transmitting loop antenna magnetic moment ( $M_T$ ), operating frequency ( $f$ ), loop to line distance ( $R$ ) and conductor separation ( $b$ ) in the line are exceedingly useful in planning the design of the communications system. The equations show

that coupling improves with the first power of magnetic moment, frequency and increased separation between line conductors. Coupling improves with the second power by distance from the loop to the line as the loop is brought nearer to the line.

Coupling depends upon the geometrical relationships between the transmitting loop antenna and the two-wire transmission line. Some of the possible geometrical relationships are illustrated in Figure 23.

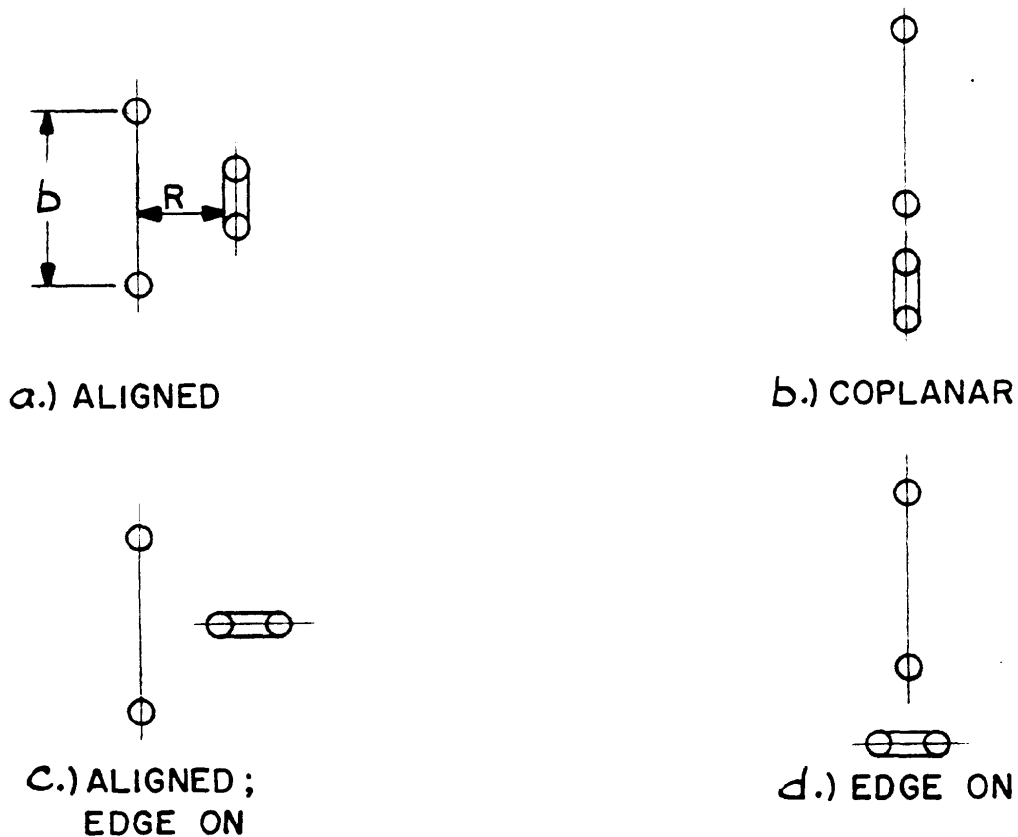

FIGURE 23. GEOMETRIES FOR A VERTICAL TRANSMISSION LINE AND TRANSMITTING LOOP ANTENNA

In the aligned case shown in Figure 23, the loop and the line conductors lie in a vertical plane. The planes are separated by the distance  $R$ . The coaxial configuration occurs when the center line of the transmission line coincides with the axis of the transmitting loop antenna. This geometry is frequently encountered when vest and vehicular transceivers are in a manway. The axis of the loop may also be below the center line of the transmission line. The coaxial alignment induces strong bifilar current in the line and weaker monofilar elements. The aligned, edge-on, case of Figure 23 (c) induces stronger monofilar currents and weaker bifilar currents. The edge-on situation produces unfavorable coupling. The coplanar case shown in Figure 23 (b) produce both monofilar and bifilar currents.

Smith (28) has developed equations that define the induced current and voltage in a transmission cable. The two-wire signal transmission medium is represented as a transmission line terminated at both ends by load impedances ( $Z_1$  and  $Z_2$ ) equal to the characteristic impedance of the line. The line is shown in Figure 24.

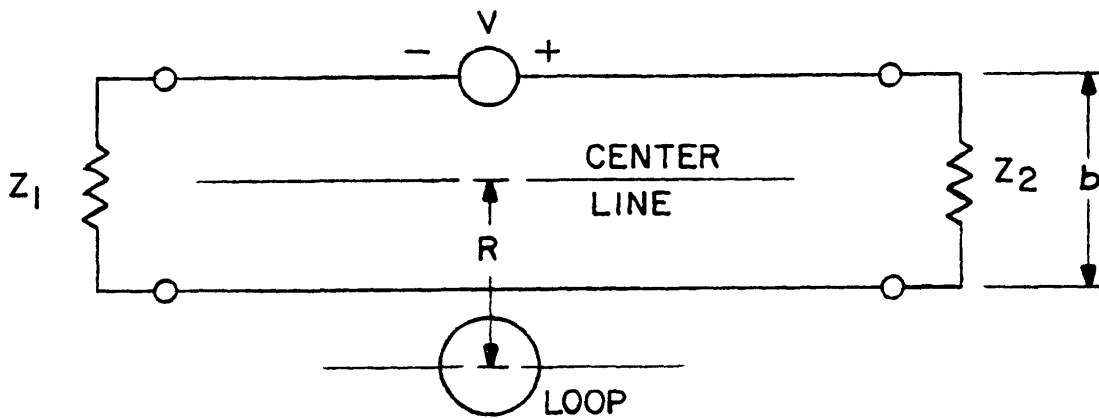

FIGURE 24. EQUIVALENT TRANSMISSION LINE NETWORK FOR INDUCED VOLTAGES AND CURRENTS ( $Z_1=Z_2=Z_0$ )

The line is long and the conductor spacing is  $b$ . The field produced by the loop threads the area enclosed by the conductor spacing and a length  $L$  along the line. Because the field is non-uniform, it is assumed to be constant over the length  $L=R$  and zero elsewhere. When  $2\pi R \ll \lambda$ , then the induced voltage is given by

$$V = \frac{\mu_0 f M_T b}{R^2} \quad (7)$$

where  $f$  is the operating frequency,

$\mu_0$  is the magnetic permeability of free space

( $4\pi \times 10^{-7}$  henrys/meter), and

$M_T$  is the loop magnetic moment.

The current flowing in the line is given by

$$I_L = \frac{V}{2 Z_0} \quad (8)$$

Equations (7) and (8) are useful in several ways. First, the voltage and current signals induced in the line are directly proportional to the magnetic moment of the transmitting loop antenna. Maximizing the loop moment for a given transmitter power will also maximize the induced signal and system operating range. Increasing the transmission line conductor spacing will increase the line characteristic impedance

$$Z_0 = 276 \log_{10} \frac{2b}{a} \quad (9)$$

and decrease line current. Since the voltage (V) depends on the first power of conductor separation b and  $Z_0$  on its logarithm. There is some improvement in operating range obtainable by maximizing b given the constraint of cable cost. Secondly, coupling efficiency increases with the first power of operating frequency (f). However, the attenuation rate of signals on the line also increases with frequency. Because of transmission loss, it is better to use lower operating frequencies. As described in Section E, the mine generated electrical noise also increases with decreases in operating frequency. Thus, although transmission losses are lower at lower operating frequency, increase in mine generated noise level causes the signal-to-noise ratio to degrade. Mine tests indicate that the signal to noise ratio (S/N) is optimized in the region of 250 to 500 kHz operating frequency band.



2. Transmitting Loop Antenna To Receiving Loop Antenna  
Via Transmission Line Coupling

At a distant receiving site, the signal magnetic field couples to the receiving loop antenna as illustrated in Figure 25.

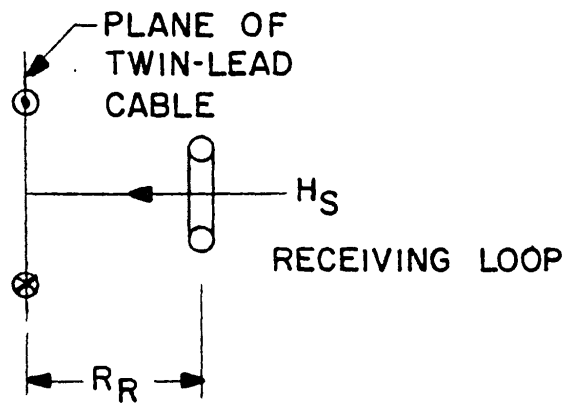

FIGURE 25. SIGNAL COUPLING TO A RECEIVING LOOP ANTENNA

The magnetic field produced by the bifilar line current along the cable near the receiving loop is mathematically represented by

$$H_S = \frac{\mu_0 f M_T b^2}{2R_T^2 [R_R^2 + (b/2)^2] Z_0} \quad (10)$$

The electromotive force (emf) produced in the receiving loop is given by Maxwell's first equation as

$$\text{emf} = \oint_C \vec{E} \cdot d\vec{l} = N_R \frac{d}{dt} \iint_A \vec{B} \cdot d\vec{n} \quad (11)$$

where  $B$  is the flux density threading the loop area  $A_R$ ,  $n$  is unit vector of surface threaded by  $\vec{B}$ , and  $N_R$  is the number of turns in the receiving loop.

The equation reduces to

$$\text{emf} = \omega \mu_0 H_S A_R N_R \quad (12)$$

Combining equations (10) and (12), the direct relationship between the transmitting antenna moment ( $M_T$ ) and the receiving loop voltage ( $V_L$ ) is obtained as

$$V_L = \frac{\pi \mu_0^2 f^2 M_T b^2 A_R N_R}{R_T^2 Z_0 [R_R^2 + (b/2)^2]} \quad (13)$$

$$\approx \frac{\pi \mu_0^2 f^2 M_T b^2 A_R N_R}{R_T^2 R_R^2 Z_0} \quad (b \ll R) \quad (14)$$

This equation is of fundamental importance in considering loop to loop via line coupling in the radio system. From the system design point of view, the voltage induced in a distant loop increases with the second power of the transmission line conductor separation (b). Transmission lines that are installed for the purpose of increasing radio coverage in manways should have the greatest possible conductor separation distance. Twin lead transmission lines used in TV lead-in applications exhibit greater conductor separation than typical twisted pair pager telephone cable. Ruggedized twin lead cable is recommended. Given the antenna physical mounting constraints (height and length), receiving loop voltage increases with the number of turns. Therefore, increasing the number of turns increases the coupling efficiency of the antenna. Coupling increases with the second power of operating frequency.

### 3. Attenuation Rate

The attenuation rate on untwisted telephone cable and AC power cable was measured in coal and M/NM mines. Measurements are extremely difficult (impossible) to accurately make in an operating mine owing to many well known factors. The principal factor is the natural variation of distance between the transmitting/receiving loop antennas and the signal transmission line in the manways. This causes uncontrollable second power of distance change effects in induced line current. Mining operations limit vehicular transportation

and prohibit disruption of the mining processes by measurement procedures. Even with these difficulties, average attenuation rates were measured in the mines shown in Table C.

The attenuation rates measured in coal and M/NM mines were found to be similar. The induced monofilar current flowing on the transmission line at the base station location was measured with a calibrated current transformer (probe).

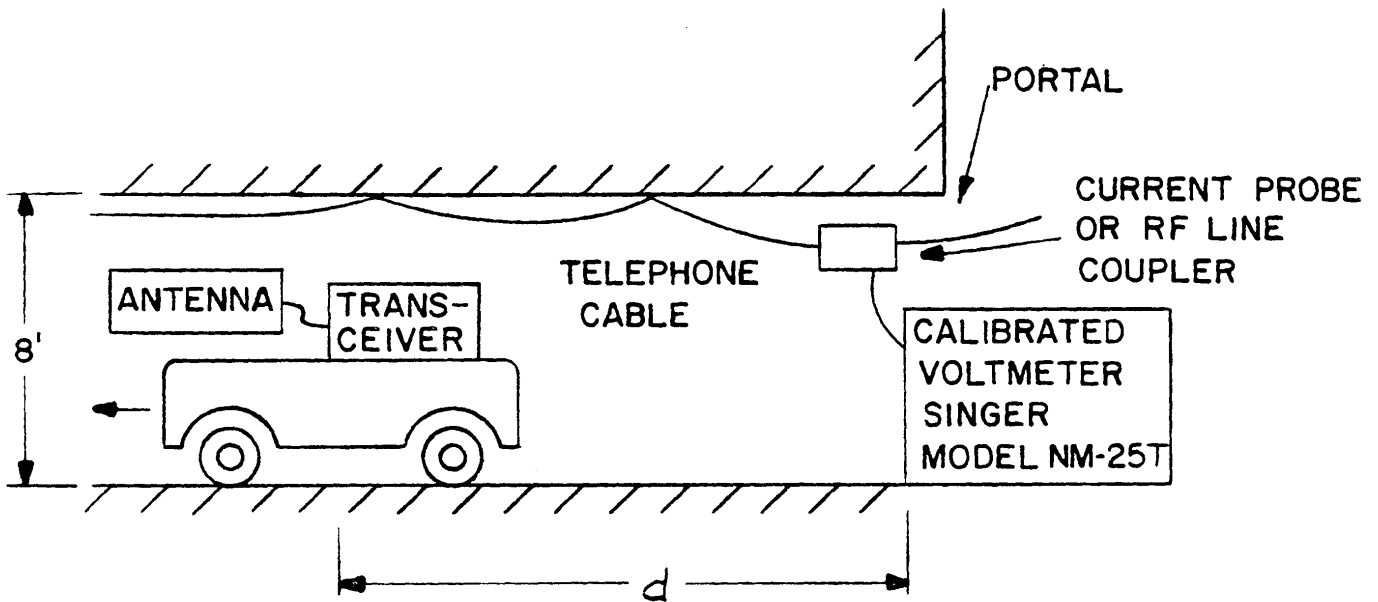
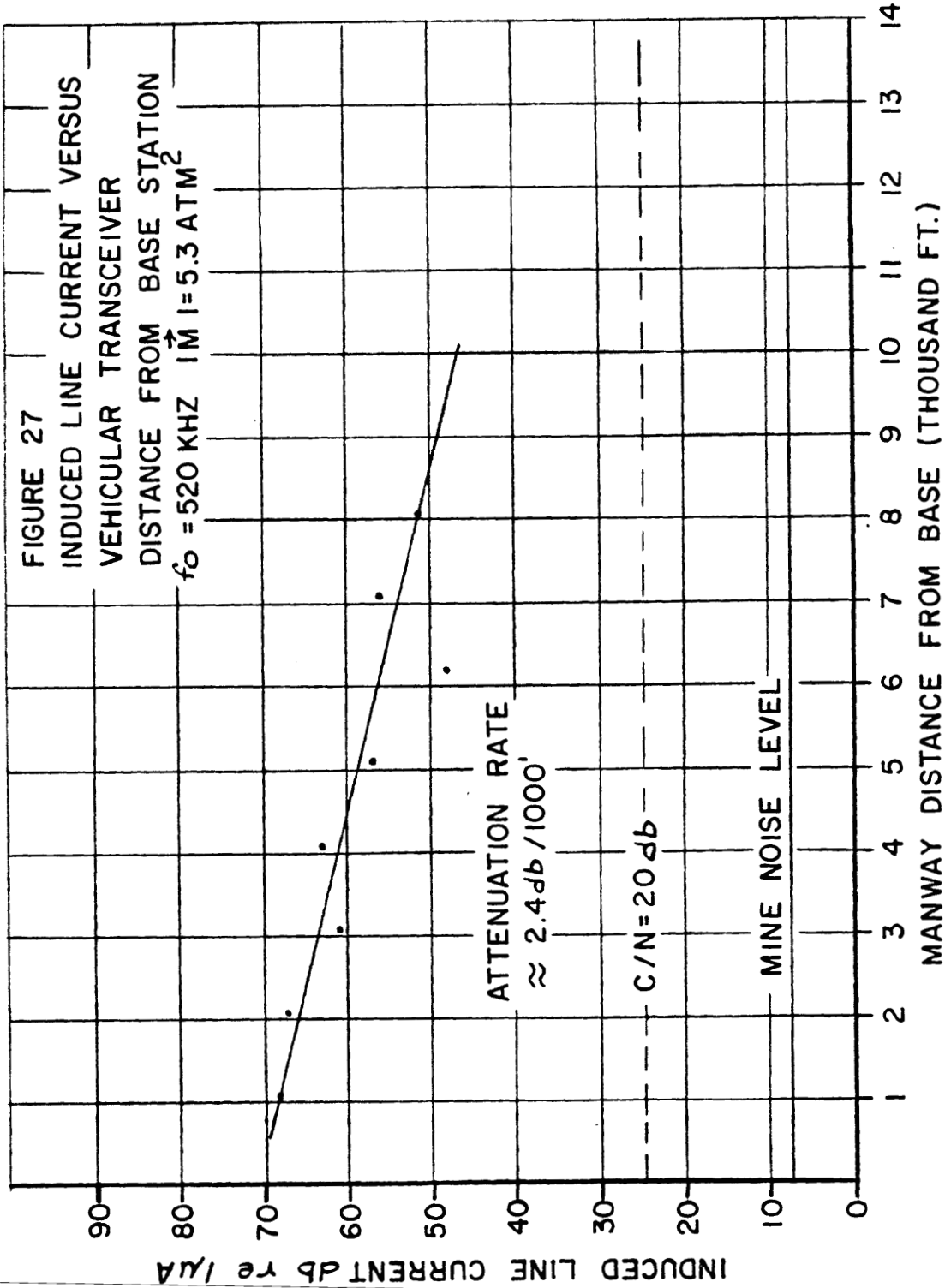

FIGURE 26. SET-UP FOR MEASURING INDUCED LINE CURRENT

Figure 26 shows that the source (transmitting loop antenna) was mounted on a mine service vehicle. The induced current was measured as the vehicle moved away from the base station location. The measured data is shown in Figure 27. The attenuation rate was approximately 2.4 dB/1000 feet.

FIGURE 27  
 INDUCED LINE CURRENT VERSUS  
 VEHICULAR TRANSCIEIVER  
 DISTANCE FROM BASE STATION  
 $f_0 = 520 \text{ KHZ}$   $I_M = 5.3 \text{ ATM}^2$



With a vehicle-to-base-station separation range of 5000 feet the induced line current was approximately 707 microamperes. The mine generated noise was also measured during each field test. The induced noise level typically measured 2.2 microamperes in a medium sized coal mine with conveyor haulage. The signal to noise ratio was found to exceed 50 dB. The horizontal dashed line (C/N=20 dB) represents the induced line current level communications. The intersection of the dashed and the protection of induced line current (not shown) curves forecast that the maximum communications range along telephone cable will exceed 18,000 feet at 520 kHz.

## G. LOOP ANTENNA DESIGN CONSIDERATIONS

The underground communication range depends upon the ability of the transmitting and receiving antennas to efficiently couple coal seam and transmission line signals. Equations (1) and (14) show that the level of signals induced on a transmission line or at the receiving antenna output terminal depends upon the first power of transmitting antenna magnetic moment ( $M_T$ ). The receiving signal also depends upon the first power of turns-area product ( $N_R A_R$ ) of the receiving antenna. The transmitting loop magnetic moment ( $M_T$ ) is produced by an excitation current ( $I$ ) flowing through the transmitting coil shown in Figure 28.

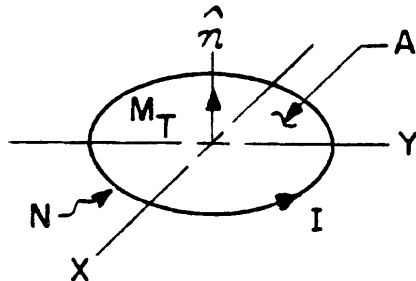

FIGURE 28. TRANSMITTING LOOP ANTENNA EXCITATION CURRENT AND MAGNETIC MOMENT<sup>(1)</sup>.

(1) The direction of the magnetic moment can be determined by the "right hand rule" whereby the fingers of the right hand point in the direction of the magnetic field when the conductor is grasped such that the right thumb points in the direction of the current.

The magnetic moment is defined as

$$| \vec{M}_T | = NIA \quad (15)$$

where A is the area of the loop in square meters,

I is the level of the excitation current, and

N is the number of turns in the transmitting loop.

The moment is a vector orthogonal to the plane of the loop.

The transmitting loop turns-current-area product (NIA) is a scalar quantity. The loop antenna produces a horizontal magnetic dipole (HMD) when the transmitting loop antenna lies in a vertical plane and a vertical magnetic dipole (VMD) when in the horizontal plane.

### 1. Design Optimization Process

Coupling can be optimized by maximizing the products (NIA) and  $(N_R A_R)$  for the transmitting and receiving antennas, respectively. Like all optimization problems, constraints placed upon the individual variables of the product significantly increases the design task. The optimization process to be described in this work examines each independent antenna design variable ( $X_i$ ) to define its upper bound ( $\hat{B}_i$ ). The upper bound for each of the variables may be written as

$$X_i \leq \hat{B}_i \quad (16)$$

where the subscripts  $i = 1, 2, 3, \dots$  identifies the variables and constrained values.



If separate antennas are used for receiving and transmitting functions, then the optimum feasible design will require different upper bounds for the antenna area and turns. If the functions are combined in a single antenna design, the same upper bounds apply. Antennas that operate in a hazardous atmosphere must necessarily have upper bounds on the transmitting antenna magnetic moment.

Physical reliability of the antenna structure imposes additional mechanical and electrical design constraints. The materials selected for use in construction of the antenna must allow the antenna to survive extreme physical abuse. The electrical component reliability must not be adversely affected by:

- . High circulating current in the loop,
- . High localized electric fields that can produce corona effects, and
- . High voltages that can break down dielectrics used in the construction of the loop components.

The antenna design constraints will be examined in the following paragraphs.

## 2. Antenna Area Constraints

Constraints placed upon the maximum antenna areas may be represented as

$$\begin{aligned} A_1 &\leq \hat{B}_1 \text{ (vest), and} \\ A_2 &\leq \hat{B}_2 \text{ (vehicular).} \end{aligned} \tag{17}$$

The upper bounds  $(\hat{B}_1, \hat{B}_2)$  are determined by straight forward examination of the antenna mounting limitations on the roving miners and many different types of underground vehicles.

### a. Vest Antenna Area Constraint

In execution of the contract work covered by this report significant improvements in the design of the "vest" type loop antenna worn by the roving miner were accomplished. These improvements were based on certain factors evident from earlier similar work of others. A short summary of technical requirements and historical developments leading to the present design follows.

The vest antenna must "fit" on the miners body, be of light weight construction and be conveniently worn by the roving miner. Any change in area of the antenna that results from the wide range of miner's physical body size or their movement during work will also change the inductance of the antenna coil. Any change in inductance will detune the antenna resulting in lower transmitting loop magnetic moment.

In the course of the extended laboratory field work, rigid oval tubular, flexible strap (bandolier) and sewn garment antennas were examined for use by roving miners. The rigid oval tubular antenna ( $\hat{B}_1 = 0.25 \text{ m}^2$ ) used on the Collins Radio Prototype MF Transceiver (FM) design was found to be onerous to roving miners.

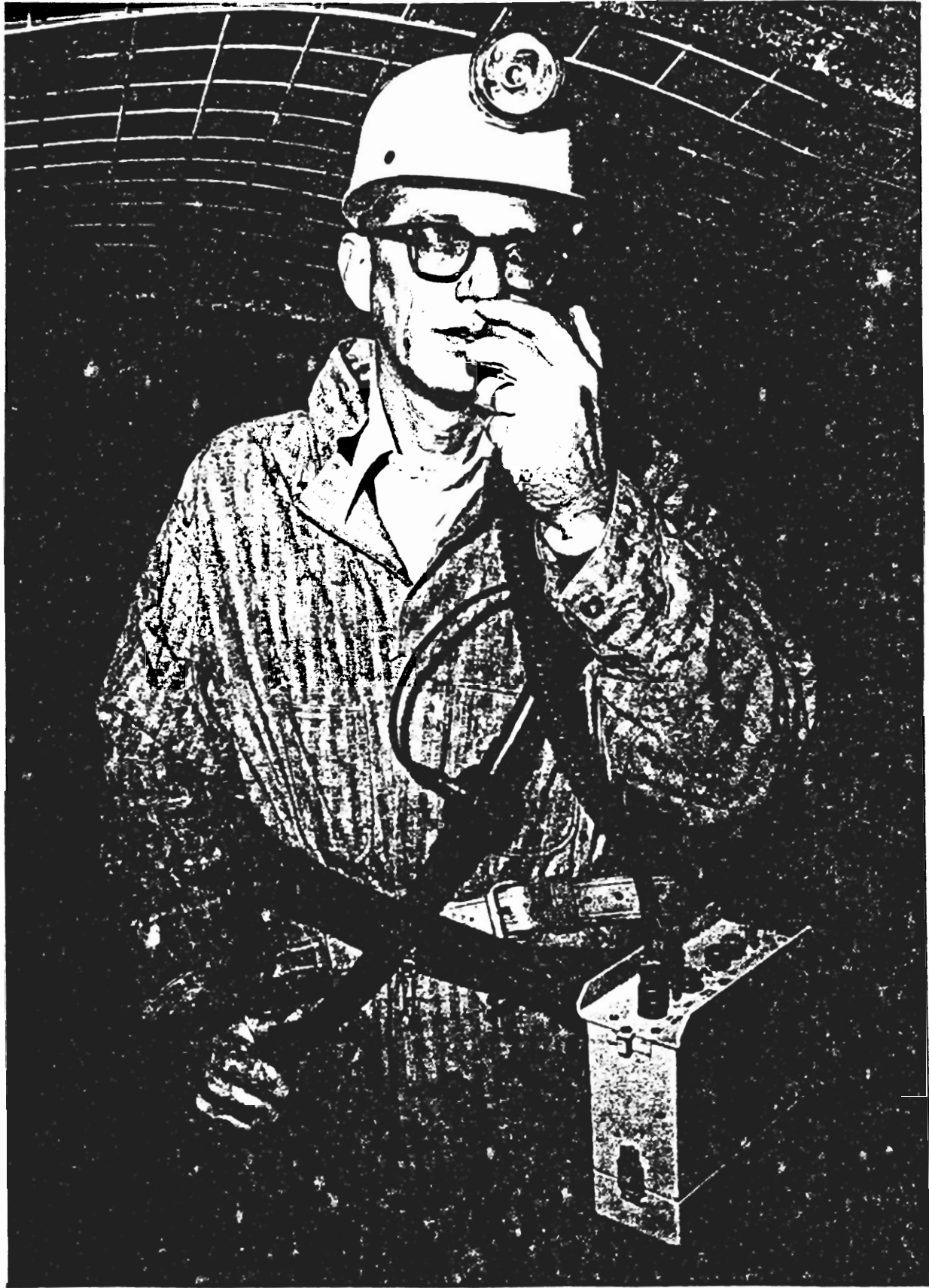

An important feature of the Collins Radio rigid tubular loop antenna design was that the area did not change with the miners' body size or movement. Because this loop design encumbered the miner, it was rejected for use in mining.

The strap-type bandolier antenna used in the South African transceiver (SSB) design satisfied many problems caused by human factor problems. Roving miners were not encumbered when "wearing" the antenna.

FIGURE 30. SOUTH AFRICAN PORTABLE MF TRANSCEIVER



The area depended upon the physical body size of the miner and his range of movement. Because of the antenna detuning affects, it cannot be used in a high performance communications system.

The Lee Engineering prototype transceiver (SSB) employed a sewn garment circular loop ( $\hat{B}_1 = 0.15 \text{ m}^2$ ). The loop was positioned over the miner's shoulder (14). Like the bandolier antenna, the area depended upon the body size of the miner.

Finally, as a result of tests conducted during this project a sewn garment antenna capable of being placed upon the front or back of the miner's work clothing was developed. The sewn garment antenna was found to maintain a constant area. For convenience of use, the antenna was sewn onto the back of a vest garment. The upper bound for the area of the vest loop antenna was found to be  $\hat{B}_1 = 0.15 \text{ m}^2$ .

b. Vehicular Antenna Area Constraint

The vehicular antenna must be of a low profile mechanical design. Tests show that the antenna coil must be situated at least five inches away from any metal surfaces to avoid the effects of detuning.

Examination of available mounting surface on various types of underground vehicles revealed that the available mounting surface area amounts to about four inches by fifteen inches. The maximum length of the antenna is twenty-eight inches. The height is fourteen inches.

The antenna surface finish must not reflect light.

The antenna must include provision for vertical and horizontal mountings.

The antenna must be sealed to prevent sulfide ore body ground water drip from contacting the internal loop components.

In the field work, rigid rectangular tubular metal, flexible rectangular tubular Lexan<sup>(1)</sup> and flexible rectangular planar Lexan antennas were evaluated on many different types of underground vehicles.

(1) General Electric trade name for polycarbonate.



High impacts caused rigid metal antenna structures to deform and change the area of the antenna. Flexible rectangular tubular Lexan structures survived very well in the mine environment.

Tubular structures are difficult to produce because multiple turns (actually multiple conductors) must be forced around bends in the rectangular tubular structure. Because the turns are confined in a circular cross section pattern, the distributed capacitance between turns is greater than would be the case if the turns were to lie in a plane.

On the other hand, the flexible planar antenna exhibited the highest unload  $Q$  ( $Q_u$ ) and self-resonant frequency of all the structures investigated. Lexan laminated planar structures were found to withstand high impact abuse in mine usage. This antenna structure was adopted for use in the program.

### 3. Design For Operation In Hazardous Atmosphere

The vest and in some circumstances, the vehicular antennas must be designed to operate in hazardous atmospheres. As a result there are two types of design constraints that necessarily occur. The first is that the stored energy within the antenna inductances and capacitances must be less than  $0.3 \times 10^{-3}$  joules. The second is that localized electric fields developed in the structure not be of sufficient strength to cause corona discharge effects or dielectric breakdowns.

The first constraint has been examined by Lagace (14). The maximum intrinsic safe transmitting loop magnetic moment may be represented as

$$\begin{aligned} M_T &= \hat{B}_3 \text{ (vest), and} \\ M_T &= \hat{B}_4 \text{ (vehicular).} \end{aligned} \quad (18)$$

For the vest,  $\hat{B}_3 = 2.5$  ampere turns meter<sup>2</sup> (ATM<sup>2</sup>). This limit follows from an analysis of Underwriters Laboratory Document 913. In mines that have hazardous environments anywhere in the mining complex, the vest transceiver design (including the antenna) must be approved by the testing and certification center, Mine Safety and Health Administration (MSHA). In fresh air and in non-gassy M/NM mines, the antennas may have greater moment.

In emergency situations, when ventilation is lost in a gassy mine, the use of non-approved radio equipment is prohibited. The design precautions related to the avoidance of excessive local electric fields causing corona effects or discharges through or on the surface of dielectrics must be very rigorously observed in order to obtain MSHA approval. Corona discharges were in fact observed during some preliminary experiments. Damage of the surface of dielectric used in structural components also did occur before safe design was realized. Relatively high RF voltages across the antenna loops may occur, as well as high RF circulating currents in the loops. Approximately 10 Amps and 1800 V peak-to-peak may be

cited as upper-bound limits of these data. It is important to bear in mind that high RF voltage per se does not cause corona effects, nor dielectric strain. The electric field, associated with RF voltage causes these effects. It is possible, by proper design, to limit these fields for a given value of RF voltage by avoiding sharp points and edges and, in general, low radii of curvature in construction. Printed circuit boards must be coated by dielectric coating, capable of withstanding high values of electric stress. Circulating RF currents must be limited in order to reduce the stored energy in the tuned antenna circuit, the safe value being less than  $0.3 (10^{-3})$  joules, as before mentioned. The rationale for the above precautions is that ionization (corona) is caused by excessive electric field and sustained by the stored energy in the circuit.

#### 4. Theoretical Basis For Loop Antenna Design

The theoretical basis for the design and optimization of a tuned loop antenna will be reviewed in this section. It will be shown that the use of a twin parallel connected coil instead of a conventional single coil occupying the same constrained antenna area offers some important advantages. First, since the twin-coil is physically smaller, its self-resonant frequency is greater than a larger single coil design. Secondly, the unloaded Q of the twin-coil is greater enabling the receiving response to a given magnetic field strength to be greater than in single coil loop. Finally, because the twin coils are connected in parallel, the terminal inductance of the coil is less than a single coil antenna with the same number of turns. Thus, the transmitting twin-coil loop produces less electric field stress across the structural components of the antenna.

The magnetic moment of any conceivable system of current loops in any given geometrical configuration is mathematically represented by

$$\vec{M}_T = 1/2 \sum \oint \vec{I}_i \vec{r} \times d\vec{l} \quad (19)$$

where vectorial integration is conducted for each coil (i) and all its turns. The symbols are:

i = running subscript identifying the coils,

$I_i$  = current in the ith coil,

$\vec{r}$  = position vector with respect to any selected origin.

The result does not depend on the selection of the origin, provided each loop is geometrically closed, and

$d\vec{l}$  = incremental vector, tangential to the loop of each coil in the direction of current flow.

The concept of magnetic moment can be used to compute electric and magnetic fields at remote locations. The definition of "remote" is a distance large as compared with the dimensions of the coil. For coplanar coils, the moment simplified to

$$\vec{M}_T = \sum \vec{\mu}_i N_i I_i A_i \quad (20)$$

where  $\vec{\mu}$  is a unit vector perpendicular to the plane of the ith loop. Its direction is determined by the "right hand" rule.

The excitation currents flowing in a twin-coil transmitting loop antenna are shown in Figure 31.

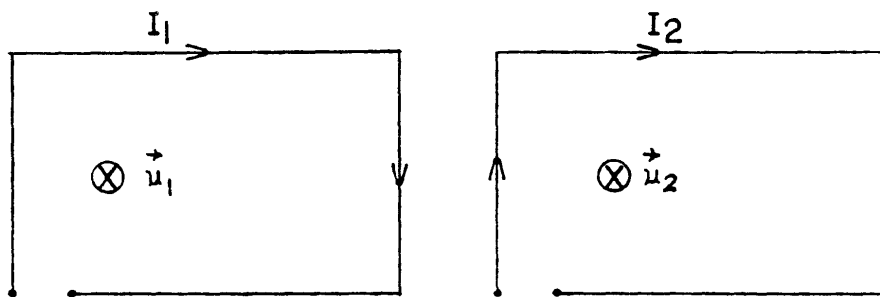

FIGURE 31. TWIN-COIL TRANSMITTING LOOP ANTENNAS

The twin-coil magnetic moment is mathematically represented by:

$$\vec{M} = \vec{\mu}_1(N_1 I_1 A_1 + N_2 I_2 A_2); \quad \vec{\mu}_1 = \vec{\mu}_2 \quad (21)$$

The equivalent circuit of a single coil loop antenna is shown in Figure 32.

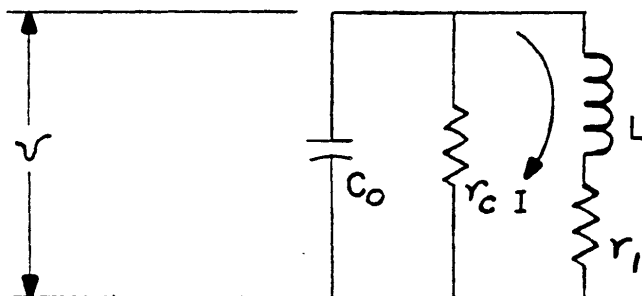

FIGURE 32. EQUIVALENT CIRCUIT OF A SINGLE-COIL LOOP ANTENNA

The inductance (L) represents the apparent inductance of the coil used in the construction of the loop antenna. It is an apparent inductance because distributed capacitance (not shown) between coil turns tune out some of the real inductance. The inductance of a planar air-core coil is mathematically approximated by:

$$L = K_o A^{\frac{1}{2}} N^2 \quad (22)$$

where A is the area in square meters,

N is the number of turns, and

$K_o$  is the form factor.

The inductance form factor depends on the ratio of the diameter (d) to the width (W) of a single layer winding. The incidental dissipation loss associated with the coil is represented as the AC ohmic resistance

$$r_1 = \frac{\omega_o L}{Q_u} \quad (23)$$

where  $Q_u$  is the unloaded Q of the coil. The capacitance ( $C_o$ ) and loop inductance are resonant at the operating frequency

$$\omega_o = \frac{1}{(LC_o)^{\frac{1}{2}}} \quad (24)$$

FIGURE 33

UNLOADED Q VERSUS FREQUENCY  
FOR A FLEXIBLE RECTANGLE  
TUBULAR LEXAN ANTENNA  
SINGLE RECTANGULAR COIL  
(36" X 8" COIL)

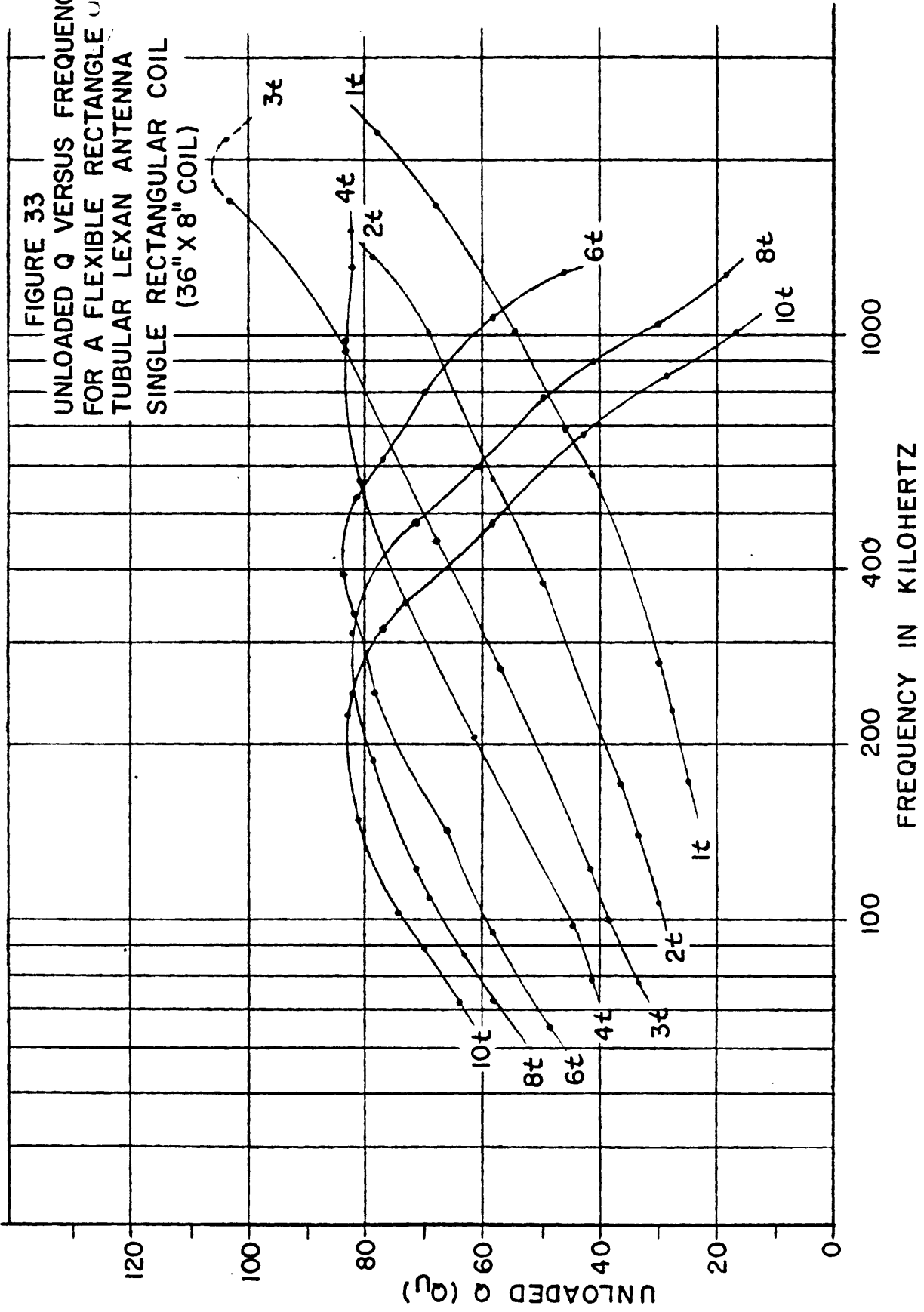
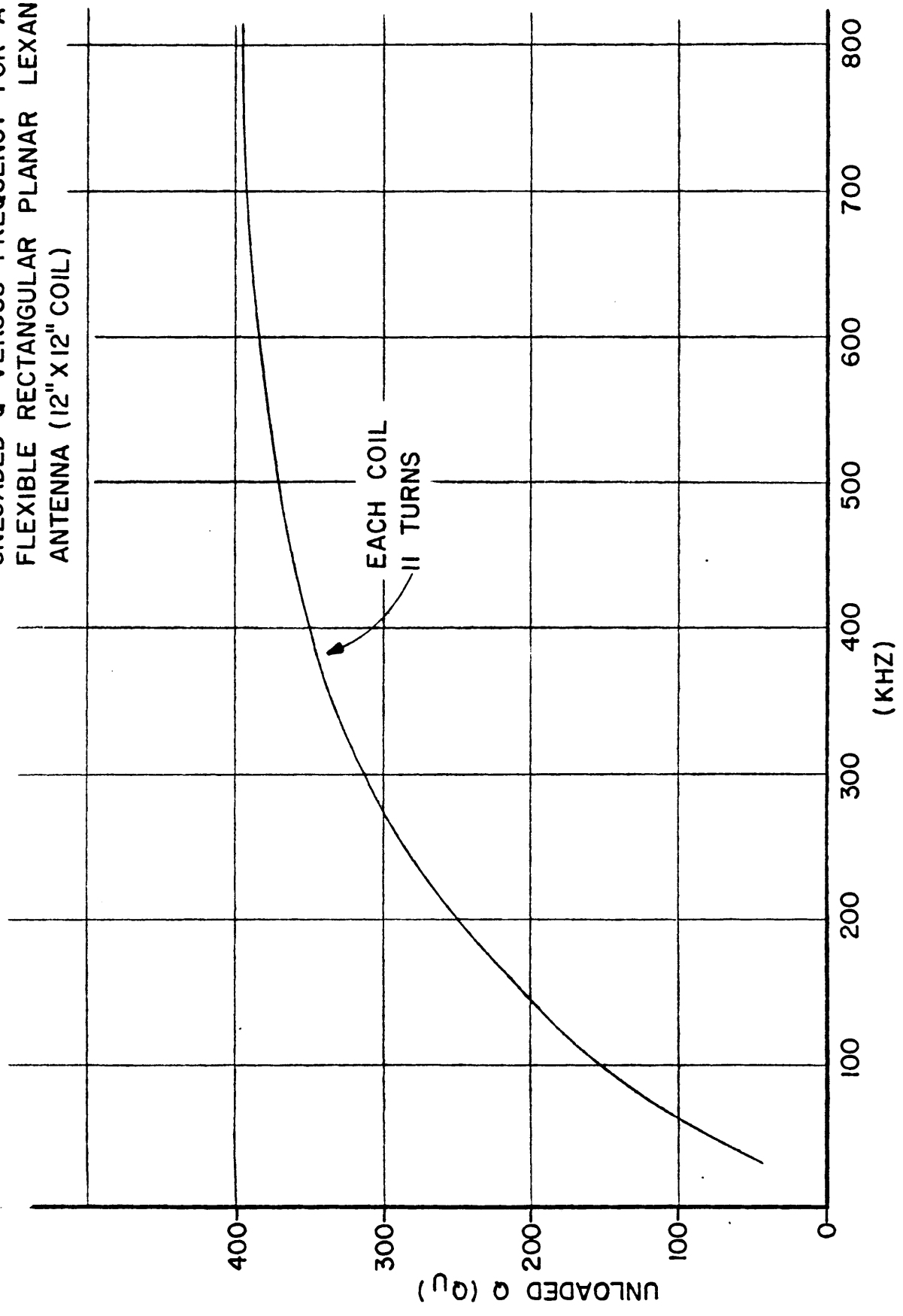



FIGURE 34  
UNLOADED Q VERSUS FREQUENCY FOR A  
FLEXIBLE RECTANGULAR PLANAR LEXAN  
ANTENNA (12" X 12" COIL)



The typical unloaded  $Q$  of tubular and planar antenna coils are shown in Figures 33 and 34. Comparison of the figures shows that the planar coil has significantly greater unloaded  $Q$ . Figure 33 shows the family of unloaded  $Q$  curves for a tubular single-coil antenna structure. The unloaded  $Q$  in the MF band degrades as turns are increased.

The ohmic value of the coil resistance ( $r_1$ ) is frequency dependent. It increases at higher frequency because of skin effects associated with current flowing in the coil conductor. When a single-coil loop antenna transmits at high power level, high electric fields between turns can produce corona effects. This also causes the apparent  $r_1$  to increase. The resistance ( $r_c$ ) represents the dissipation loss associated with the tuning capacitance ( $C_o$ ) depending upon the type of tuning capacitor, the loss resistance ( $r_c$ ) may decrease with increases in operating frequency and the level of current flowing through the capacitance. The transmitter to loop matching network may be realized by using two capacitors as shown in Figure 35.

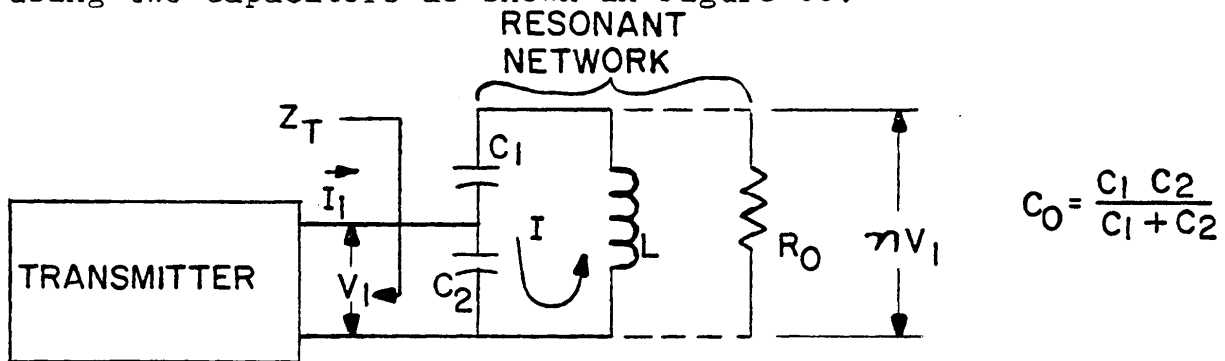

FIGURE 35. TYPICAL MATCHING NETWORK

The transmitter output impedance ( $Z_T$ ) is transformed by the matching network and becomes part of the resonant network.

The transformation ratio ( $n$ ) is given by

$$n = 1 + \frac{C_2}{C_1} . \quad (25)$$

Impedances are transformed by the second power of  $n$  and voltage by the first power of  $n$ .

The resistance  $R_o$  is the impedance of the resonant network at the antenna operating frequency ( $\omega_o$ ) and is given by

$$R_o = \omega_o L Q_{CKT} . \quad (26)$$

The circuit  $Q$  for the antenna structure is

$$Q_{CKT} = \frac{\omega_o}{BW} \quad (27)$$

where  $BW$  is the 3 dB radian frequency bandwidth of the antenna.

Because low dissipation loss porcelain capacitors are used in the structure, the ohmic value of  $r_c$  (shown in Figure 32) is much greater than  $R_o$ . Under this condition, the resistance ( $R_o$ ) represents only the parallel combination of the transformed transmitter output impedance and the ohmic value of the coil loss given by

$$R_{coil} = \omega_o L Q_u . \quad (28)$$

When  $R_o$  is large and  $I_1 \leq I$ , then

$$\frac{I}{\omega C_o} = nV_1, \text{ and} \quad (29)$$

$$\frac{I}{\omega C_2} = V_1 . \quad (30)$$

The circuit capacitances are mathematically represented by

$$\frac{1}{C_1} = \frac{1}{C_o} - \frac{1}{C_2} , \text{ and} \quad (31)$$

$$\frac{C_o}{C_1} = 1 - \frac{1}{n} . \quad (32)$$

when  $n$  is large, then  $C_o \doteq C_1$ . Under this condition the upper capacitor primarily determines the resonance frequency of the antenna structure. When the loop is transmitting, the capacitor ( $C_1$ ) must withstand the RF voltage developed across the coil.

In our case the transmitting loop antenna is also used for receiving (as a receiver input circuit). The matching to the receiver input, with the aid of the capacitive voltage divider of the ratio (n) must represent a good design compromise with the transmitting application. It must safeguard an acceptable value of receiving input bandwidth. The higher the unloaded Q value of the loop winding, the better will be the efficiency of signal power transition to the receiver input.

The RF voltage (V) appearing across the inductances and capacitances in a transmitting antenna structure is mathematically represented by

$$V = |\omega_0 LI|. \quad (33)$$

When considering the antenna design problem, the question of whether to use separate antennas for transmitting and receiving or to combine the functions into a single structure naturally arises. Receiving antennas are optimized by maximizing the number of turns ( $N_R$ ) in the loop. A transmitting loop can have fewer turns. Regardless of how the antennas are used, the self-resonant frequency must be above the operating frequency range of the communications system. A ferrite core antenna cannot be used for a transmitting loop. Ferrite antennas are significantly more lossy (lower  $Q_U$ ) than are air-core loops and change inductance at high power level. As a result, they produce significant smaller magnetic moments. The lower  $Q_U$  of the ferrite loop degrades the magnetic field sensitivity of the receiving loop (i.e., requires greater n).

---

From the stand point of realizing the highest self-resonant frequency in the loop antenna design, the optimum loop shape is planar. This coil configuration minimizes the self-capacitance between turns. Capacitance can be reduced further by spacing adjacent turns. Spacing adjacent turns reduces the electric field gradient between turns. It should be noted that the gradient can be partially canceled in a coil by crossover winding techniques.

When the antenna area is constrained (as it is in this design problem), Dr. Hupert (38) has shown that transmitting loop magnetic moment may be represented by

$$|\vec{M}| \propto k_1 \sqrt{\frac{P}{BW}} \quad (34)$$

where P is the power dissipated in the loop, and

$k_1$  is a constant that depends on area.

Equation (34) is relevant in the antenna optimization problem. The moment depends only on power and bandwidth and not on turns(N). Equation (14) shows that receiving sensitivity of an antenna increases with turns. Thus the receiving function of a combination transmitting/receiving loop can be optimized by increasing turns. As a practical matter, turns can be increased until the self-resonant

frequency of the coil approaches the operating frequency band from above. Another limit on turns is implied in Equation (33). Since  $L$  increases with the second power of turns, maximum turns is also determined by the dielectric withstanding voltage of the capacitors and coils used in the structure.

The principal objectives in the antenna design are:

- . To optimize the design of a combination transmitting and receiving loop antenna, and
- . To optimize the available area in order to design loop antenna capable of highest magnetic moment with the lowest RF voltage across it.

The last objective led to the solution involving twin parallel-loops forming the antenna in preference to an antenna using a single loop. The reduction in voltage between single and twin-coil loop antenna designs will be examined on the basis of equal power dissipation and loaded circuit  $Q$ . Both antenna designs will be assumed to have the same number of turns and occupy the same total surface area. The area of each twin-coil is one-half of that of single coil area. The inductance given by Equation (22) of the twin-coil is assumed to be proportional to the square root of the applicable area. In addition, besides the area difference, the twin-coils are mutually coupled and their mutual coupling should be taken into account.

The power (P) dissipated in the single coil loop with an inductance (L) and ohmic loss resistance ( $r_1$ ) is given by

$$P = \frac{I^2}{2} r_1 = \frac{I^2}{2} \left( \frac{\omega_o L}{Q_{CKT}} \right) \quad (35)$$

In a twin-coil loop, the dissipated power is mathematically represented by

$$P = 2 \left( \frac{I_T^2}{2} r_1' \right) = I_T^2 \frac{\omega_o L_{T'}}{Q_{CKT}} \quad (36)$$

where  $I_T'$  is the inductance of a single coil in the twin-coil structure. The inductance includes the effects of mutual coupling and smaller area of the coil. By equating Equations (35) and (36), the relationship between current flowing in a single coil and in each coil of the twin-coil structure is given by

$$I_T = I \sqrt{\frac{L}{2L_{T'}}} \quad (37)$$

The RF voltages are to be compared at resonance. The RF voltage ( $V_S$ ) appearing across a single coil and the voltage ( $V_T$ ) appearing across a twin-coil structures are

$$V_S = |I \omega_o L| \text{ (single coil)} \quad (38)$$

$$V_T = |I_T \omega_o L_T'| = |I \omega_o \sqrt{\frac{LL'}{2}}| \text{ (twin coil)} \quad (39)$$



The voltage developed across the twin-coil is clearly less than that developed across the single-coil.

The currents and inductances in the mutually coupled twin-coil loop will be determined in the following coupled circuit analysis.

The mutual coupling (M) in the twin-coil loop antenna is illustrated in Figure 36.

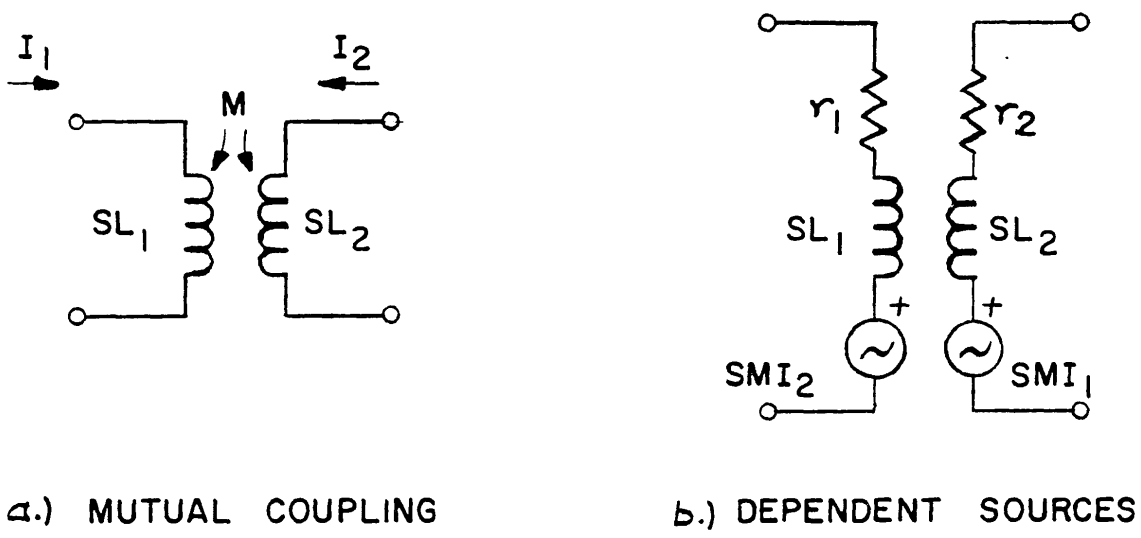

FIGURE 36. INDUCTIVE COUPLING IN THE TWIN-COIL LOOP ANTENNA

The dependent voltage sources (shown in Figure 36(b)) have been substituted for mutual coupling. Assuming that the coils are identical, the branch impedances are

$$Z_1 = r_1 + SL_1 = r_2 + SL_2 = Z_2 \quad (40)$$

where  $S$  is the Laplace operator and  $(r_1 r_2)$  represents the ohmic value of the dissipation loss associated with each coil as well as the equivalent load.

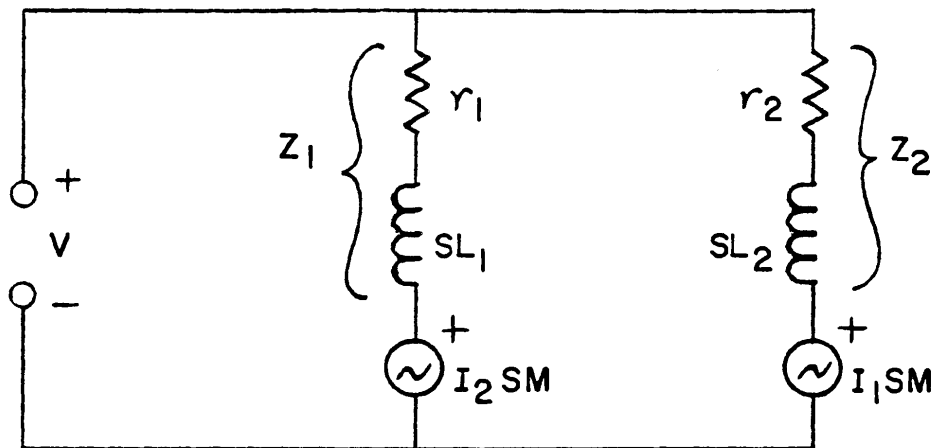

FIGURE 37. EQUIVALENT CIRCUIT OF THE TWIN-COIL LOOP ANTENNA

The voltage common to both loops can be expressed as

$$V = I_1 Z_1 + I_2 SM \quad (41)$$

$$V = I_2 Z_2 + I_1 SM \quad (42)$$

from these equations

$$I_2 = \frac{V - I_1 SM}{Z_2} \quad (43)$$

and

$$\frac{V}{Z} = I_1 + \frac{I_2 SM}{Z_1} \quad (44)$$

then

$$\frac{V}{I_1} = I_1 + \frac{VSM}{Z_1 Z_2} - I_1 \frac{(SM)^2}{Z_1 Z_2} \quad (45)$$

The branch current becomes

$$I_1 = \frac{V}{Z_1} \frac{\left(1 - \frac{SM}{Z_2}\right)}{1 - \frac{(SM)^2}{Z_1 Z_2}} \quad (46)$$

Since  $SM = k \sqrt{S^2 L_1 L_2}$  and that

$$Z_1 = Z_2 = SL_1 \quad (47)$$

then

$$I = \frac{V}{SL_1} \frac{(1 - k)}{(1 - k^2)} \quad \text{or} \quad (48)$$

$$I_1 = \frac{V}{SL_T'} \quad (49)$$

where the inductance ( $L_T'$ ) is given by

$$L_T' = L_1 \frac{(1 - k^2)}{1 - k} = L_1 (1+k). \quad (50)$$

Equation (50) allows the twin-coil loop antenna structure to be considered as composed of two uncoupled coils of inductance  $L_T'$ . The range of coil coupling is

$$|k| \leq 1 \quad (51)$$

TABLE G  
 COMPARISON SINGLE AND TWIN-COIL  
 VEHICULAR ANTENNA CHARACTERISTICS

| PARAMETER                     | SINGLE-COIL | TWIN-COIL |
|-------------------------------|-------------|-----------|
| Frequency (kHz)               | 400         | 400       |
| Bandwidth (kHz)               | 12          | 12        |
| Turns (N)                     | 11          | 11        |
| Inductance ( $\mu\text{H}$ )  | 149         | 43.5      |
| Area ( $\text{m}^2$ )         | 0.161       | 0.168     |
| Unloaded Q ( $Q_U$ )          | 275         | 321       |
| Capacitance                   |             |           |
| C1 (Pf)                       | 1160        | 4240      |
| C2 (Pf)                       | 15950       | 27200     |
| C0 (Pf)                       | 1081        | 3668      |
| $n = 1 + C2/C1$               | 14.75       | 7.42      |
| $\omega_0 L$ (ohms)           | 374         | 109       |
| RF Voltage ( $V_{PP}$ )       | 2365        | 1298      |
| V1 Voltage ( $V_{PP}$ )       | 222.5       | 205       |
| Loop Current (each coil)      |             |           |
| I ( $A_{PP}$ )                | 6.32        | 5.95      |
| Moment ( $\text{ATM}^2$ peak) | 5.6         | 5.5       |

The tabular results are noteworthy in several respects. First of all, even though the circuit Q of both antennas are identical, the unloaded Q of the individual coils are not. This follows from the fact that the smaller planar twin-coil exhibits a higher self-resonance frequency (2.8 as compared to 1.5 MHz in the single coil). Secondly, the RF voltage appearing across the twin-coil structure is less than the voltage appearing across a single coil structure. The relative ratio of 0.55 compares closely with the value of predicted by Equation (55). The magnetic moments were found to be almost identical in the single and twin-coil loop antennas. This was attributed to the non-linear behavior of the source impedance. In summary, the twin-coil loop antenna RF voltage for a given magnetic moment is less than in a single coil design. Because of the lower operating voltage, the dielectric withstanding voltage requirements are less severe.

---

The magnetic moments of single-coil ( $|\vec{M}_S|$ ) and twin-coil structures ( $|\vec{M}_T|$ ) are

$$|\vec{M}_S| = NIA \quad (\text{single coil}) \quad (52)$$

$$|\vec{M}_T| = 2N(I_T)\left(\frac{A}{2}\right)$$

$$|\vec{M}_T| = |\vec{M}_S| \sqrt{\frac{L}{2L_T'}} \quad (\text{twin-coil}) \quad (53)$$

In the case of the planar twin-coil structure, the mutual coupling coefficient is negative and approximately

$$k = -.1.$$

Then, the uncoupled inductance of each coil of the twin-coil follows from Equation (50) as

$$L_T' = 0.9L_1 \quad \text{and}$$

since

$$L_1 = L/\sqrt{2}, \quad \text{then}$$

$$L_T' = 0.64L. \quad (54)$$

By substituting Equation (54) into Equation (39) and Equation (53), a direct comparison of RF voltage and magnetic moment can be made between a single and twin-coil antenna as

$$V_T = 0.57 V_S \quad \text{and}$$

$$|\vec{M}_T| = 0.88 |\vec{M}_S|. \quad (55)$$

Single and twin-coil planar loop antennas were constructed and evaluated in our laboratory. The antennas were each driven from a vehicular transceiver. The loop design parameters and measured results are shown in Table G.

During the test, the DC power applied to the vehicular transceiver power amplifier was 26.4 watts. When the transceiver was terminated by a 50 ohm power meter, the power meter reading was 20 watts. The capacitances  $C_1$  and  $C_2$  are used to couple the transmitter (source) to the loop antenna coils. The transmitter output impedance (antenna source impedance  $Z_S$ ) is known to be non-linear. The capacitance values were selected to produce an apparent circuit bandwidth of 12 kHz centered about the operating frequency (400 kHz). When the loop antenna is used as a receiver, it is terminated by vehicular transceiver receiver input impedance (50 ohms). The measured receiving bandwidth is approximately 12 kHz.

## H. RF LINE COUPLER DESIGN

Many of the considerations which are important in the design of loop antennas are also important in the design of RF line couplers. The RF line coupler is a multiple-turn toroidal air-core current transformer.

Equivalent circuit of the RF line coupler is shown

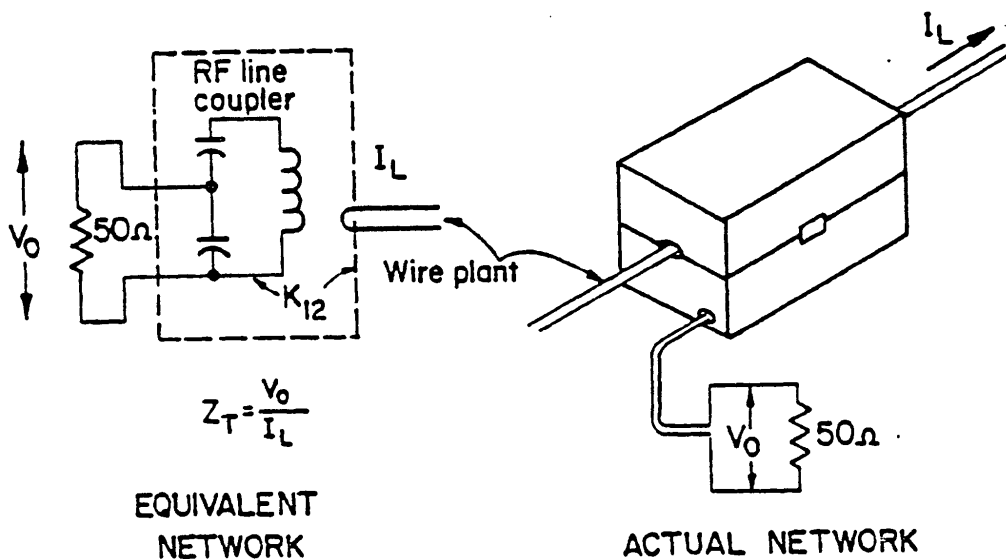

FIGURE 38. RF LINE COUPLER



The "wireplant" conductor becomes a single turn on the secondary of the transformer. The transfer impedance of the coupler is given by

$$Z_T = \frac{V_L}{I_L} \quad (56)$$

where  $V_L$  is the coupler output voltage and

$I_L$  is the line current flowing in any "wireplant" conductor.

If the coupler exhibits a higher transfer impedance ( $Z_T$ ), the output voltage applied to the receiver is greater. Thus, coupler efficiency can be characterized by its impedance.

Coupling of "wireplant" signals to the toroidal coupler is illustrated in Figure 39.

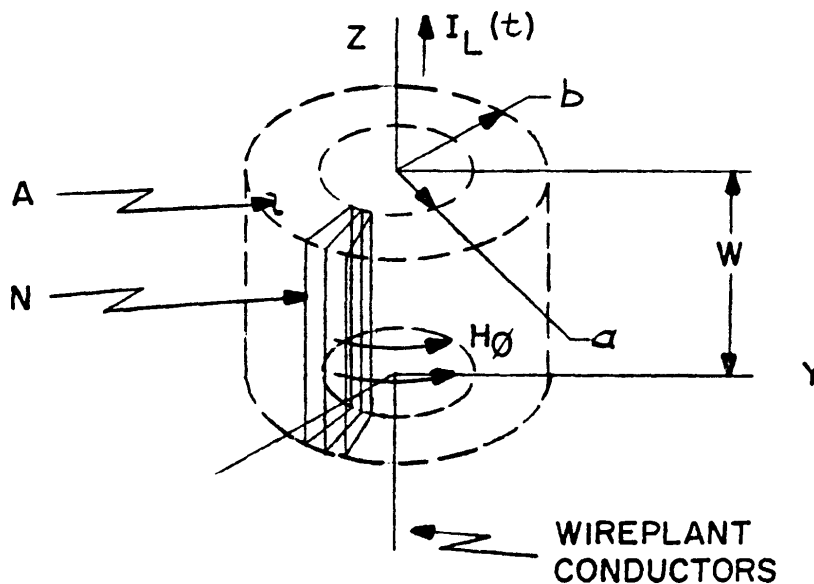

FIGURE 39. SIGNAL COUPLING FROM THE WIREPLANT (CYLINDRICAL COORDINATES  $r, z, \phi$ )

The time dependent line current flowing through the center of the toroidal coil along the Z axis is

$$I_L(t) = I_L \text{ SIN}\omega_0 t \quad (57)$$

From Amperes Law, the magnetic field at a radial distance (r) from the line current is given by

$$\vec{H}_\phi = \frac{I_L}{2\pi r} a_\phi \quad (\text{ampere/meter}) \quad (58)$$

where  $a_\phi$  is the azimuthal unit vector in the cylindrical coordinate system. The magnetic flux density in free space is

$$\vec{B}_\phi = \mu_0 \vec{H}_\phi \quad (\text{Weber/meter}). \quad (59)$$

The magnetic flux ( $\phi$ ) passing through the area enclosed by each turn of the toroidal coil is

$$\phi = \int \vec{B}_\phi \cdot \vec{da} = \frac{\mu_0 I_L(t)}{2\pi} \int_0^w \int_a^b \frac{dr}{r} dz. \quad (60)$$

The voltage induced in N turn is given by Faraday's Law:

$$V(\text{emf}) = -N \frac{d\phi}{dt} \quad (61)$$

Substituting Equation (60) into (61) and differentiating with respect to time, the induced voltage is mathematically given by

$$\text{emf} = \mu_0 N I_L f W L \ln(b/a). \quad (62)$$

When a capacitance matching network is used in the coupler design (see Figure 35), the transfer impedance of the coupling structure may be mathematically represented by

$$Z_T = \frac{V_L}{I_L} = \frac{-\mu_0 N I_L f W \ln\left(\frac{b}{a}\right)}{n} \quad (63)$$

The transfer impedance increases with the first power of turns, current level, operating frequency and length (W) of the coupler. It decreases with the first power of n. It increases with the logarithm of the ratio of inside to outside diameter of the coil.

The operating range between transceivers along a transmission line pair (which supports the bifilar mode) will exhibit an optimum value with respect to frequency. This occurs because both the coupling efficiency and signal attenuation rate increases with frequency.

The transfer impedance of a 1 inch coupler was measured and the results are shown in the following table.

TABLE H  
RF LINE COUPLER  
TRANSFER IMPEDANCE  
(1 INCH)

| <u>Test Frequency</u> | <u>Transfer Impedance (ohms)</u> |
|-----------------------|----------------------------------|
| 350 kHz               | 10                               |
| 520 kHz               | 11.2                             |

The induced current flow in the "wireplant" by a transmitting coupler is dependent upon the resistance (impedance) of the conductors. The induced current was measured in the test set-up shown below.

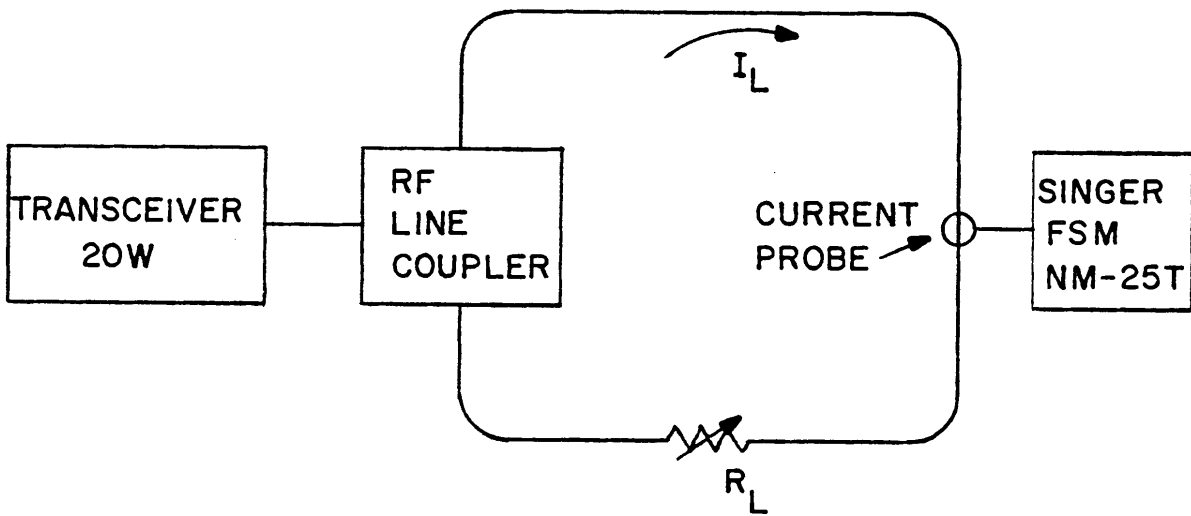

FIGURE 40. TEST SET-UP FOR MEASURING INDUCED CURRENT AS A FUNCTION OF LINE RESISTANCE ( $R_L$ )

On A.R.F.'s antenna range, multiple conductors were placed in the RF line coupler as illustrated below.

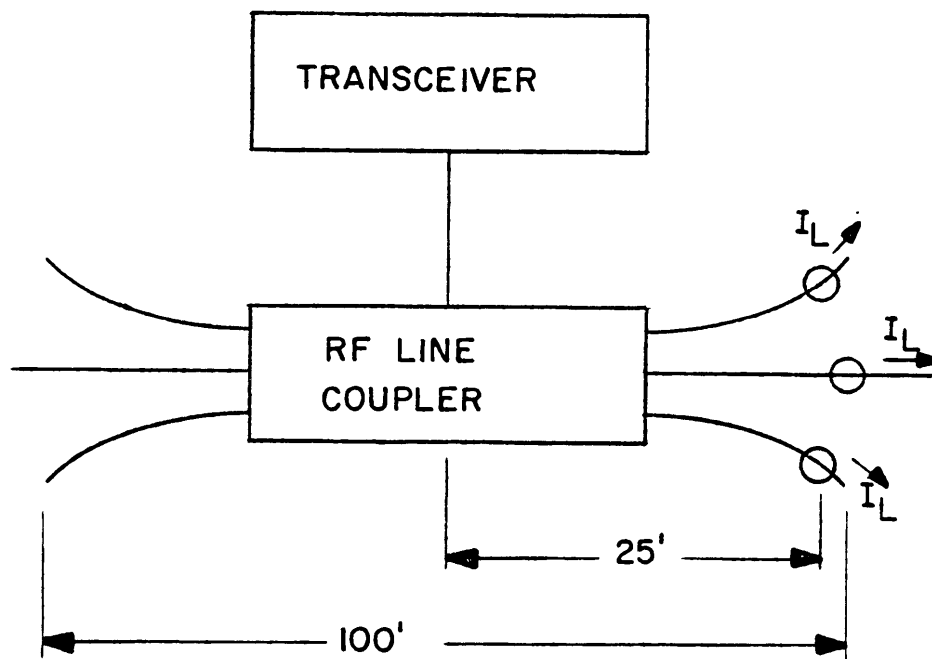

FIGURE 41. OVER THE EARTH MULTIPLE WIRE COUPLING

The circle symbols show the location where the standard current probe was used to measure induced line current. As expected the line current in a remaining conductor did not change when other conductors were removed from the RF line coupler. In this test, the coupler can be modeled as a tuned primary transformer with a multifilar secondary winding.

At 530 kHz, the induced current was measured to be approximately 3.9 mA in each wire. Data presented in Table I indicates that the apparent line and earth circuit resistance is greater than 2000 ohms. In mine tunnels, the apparent resistance of telephone cable is also approximately 2000 ohms.

#### I. MODULATION PROCESSES

The practical quality of a communication system is judged by the human ear. Listeners judge quality by the naturalness of the speaker's voice, background noise level and the like. In the laboratory, quality is judged by analyzing the recovered audio signal at the output of the receiver. The measurement of recovered audio signal to noise ratio  $(S/N)_o$  has come into being as a reliable measurement standard.

The recovered audio output signal to noise ratio may be maximized by enhancing the signal in the presence of noise. Predetection filtering is useful in discriminating against noise that occurs outside of the occupied bandwidth of the modulated signal. Noise discrimination improves by selecting higher operating frequencies ( $F_o$ ) and by using the narrowest post detection bandwidth that is compatible with the modulated signal.

Spread spectrum modulating processes have the ability of increasing the recovered output signal to noise ratio by providing process gain in the communication channel. Process gain is the result of subsequent bandwidth spreading and de-spreading operation. One of the most familiar of the spread spectrum modulation processes is seen in conventional frequency modulation (FM) where the modulation process produces a much wider occupied bandwidth than the information bandwidth.

Figure 42 shows the process gain characteristics for FM, SSB, and AM modulation processes. FM process gain increases with the modulation index (B) given by

$$B = \frac{\Delta f}{f_m} \quad (64)$$

where  $\Delta f$  is the peak frequency deviation and  $f_m$  is the highest frequency in the modulating signal spectrum.

The break in the slope of the FM characteristics marks the threshold in process gain. For carrier to noise (S/N) ratios below the threshold value, the recovered signal to noise  $(S/N)_o$  ratio rapidly degrades.

Single sideband (SSB) characteristic is noteworthy in that it does not exhibit a threshold.

FIGURE 42 TYPICAL MODULATION PROCESS GAIN

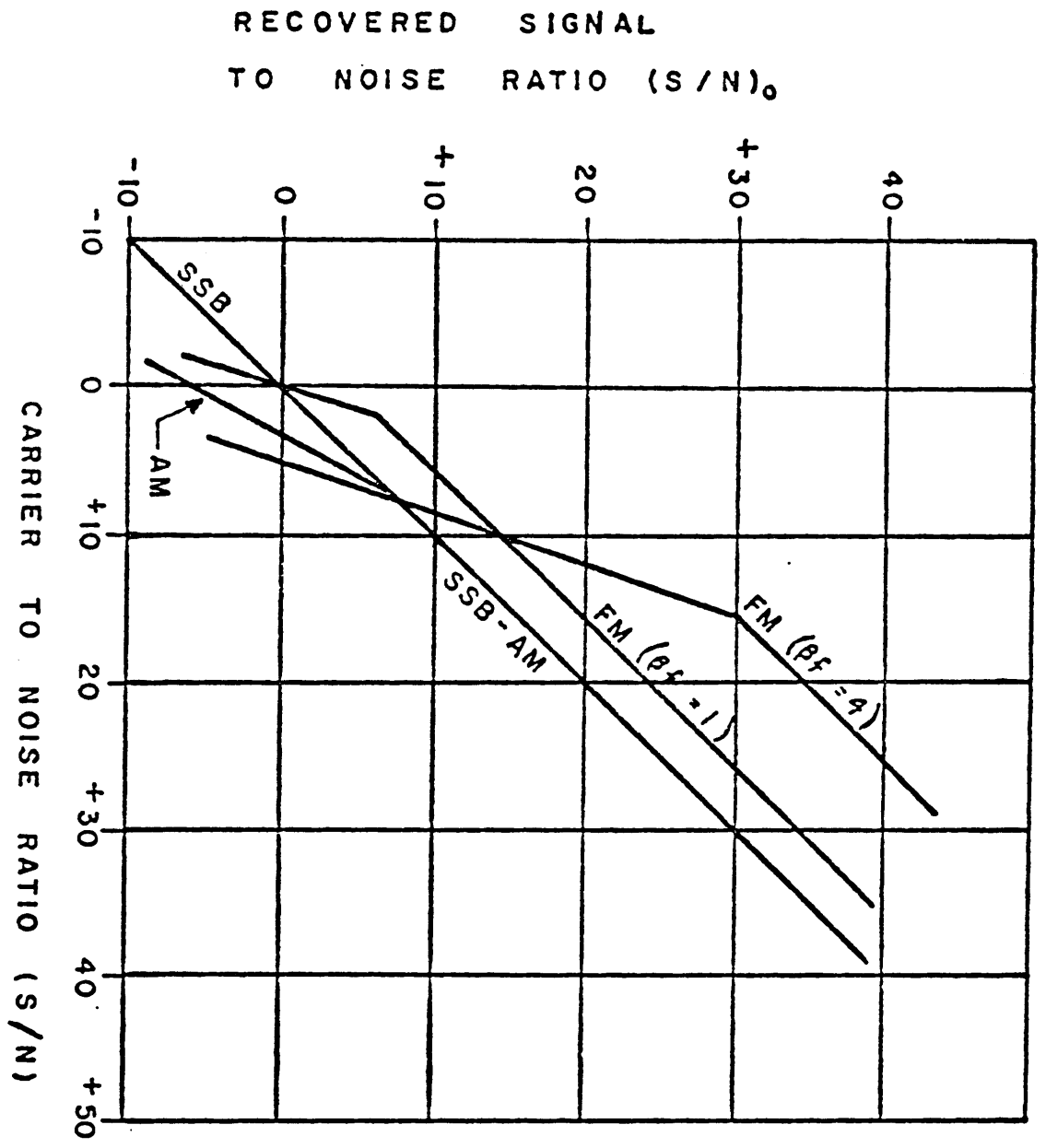



By considering only process gain, FM has an advantage in a communication system that can be operated with a large carrier to noise ratio. The advantage, of course, depends upon the modulation index and the carrier signal to noise ratio. In the "near" field communication system, the combined effects of "near" field propagation loss and noise, force the carrier to noise ratio to be low some of the time. Because SSB does not exhibit a threshold, it might be preferable in some cases.

In today's congested-band terrestrial radio services, SSB is favored because the RF occupied bandwidth is the same as the information bandwidth. This means that many more user service channels can co-inhabit the assigned service channel. On the other hand, the occupied bandwidth of an FM signal as given by

$$BW = 2f_m + 2 \Delta f \quad (65)$$

OR

$$BW = 2 \Delta f \text{ where } \beta < 1 \quad (66)$$

is much greater than the information bandwidth.

Since the communication system does not operate by means of a radiated field, but rather by an induction field, the magnetic moment (M) of the antenna is to be maximized. For a given transmitter output power and loop area, reducing the bandwidth (BW) of the loop increases the magnetic moment as shown in Equation (33).

$$|\vec{M}| \propto \sqrt{\frac{P_o}{BW}} \quad (33)$$

The occupied bandwidth of the loop current signal must be within the bandwidth (BW) of the tuned loop. The tuned loop antenna attenuates signal components that occur near the band edge frequencies of the loop passband. The loop antenna will not faithfully reproduce magnetic moments for these band edge signal components. When loop bandwidth is less than the occupied bandwidth, the modulation index B is reduced in the carrier signal. The modulated carrier signal occupied bandwidth determines the circuit Q ( $Q_{CKT}$ ) of the loop antenna as

$$Q_{CKT} = \frac{\omega_o}{BW_{CKT}} \quad (27)$$

In practice,  $Q_{CKT}$  is bounded by realizability considerations. The lower bound is determined by the available transceiver power supply voltage and the current drive capability of the power amplifier. The higher bound is determined by unloaded Q ( $Q_u$ ) of the antenna structure. The lower  $Q_{CKT}$  bound militates against the use of wideband FM in the communication system.

SSB and narrowband FM can be compared on the basis of occupied bandwidth. The SSB circuit bandwidth can be one-half that required for narrowband FM. With respect to equivalent magnetic moment generated by the transmitting loop antenna, the SSB transmitter power can be 3 dB less than the FM transmitter power. On the other hand, an SSB loop antenna matching network will require a higher transfer ratio ( $n$ ). The higher ratio makes the SSB antenna more sensitive to loading caused by nearby metal objects. Loading will cause the terminal impedance of the antenna to change. The Automatic Level Control (ALC) associated with the SSB transmitter will cause output power to vary with loading. By way of contrast, a FM transmitter final amplifier can be designed to produce almost constant load plane power over a wide range of impedance. Thus a narrowband FM transmitter is expected to produce constant power over a range of incidental antenna loading conditions.

From the standpoint of received noise, narrowband FM would appear to have an advantage over SSB because of limiting in the FM receiver. It turns out that repetitive impulse-like behavior of the mine noise causes the predetection circuits, including the limiter network in the FM receiver, to ring, degrading the recovered  $(S/N)_o$  ratio. As long as the carrier level exceeds the noise by 10 dB, the quality of the recovered voice signal is acceptable. On the other hand, impulsive noise causes the SSB automatic gain control (AGC) circuit to immediately desensitize the receiver with each

---

noise burst for the release period (time constant) of the AGC. Because of the way AGC control signals are developed, decreasing the release period below a certain value causes instability in the AGC control circuit. While impulse noise degrades the FM receiver recovered audio signal quality, an SSB receiver is desensitized for the AGC release period which dramatically reduces the intelligibility of the voice signal.

The operating range of prototype 1 Watt FM transceivers was compared to 1 Watt SSB transceivers in the York Canyon mine near Raton, New Mexico. Before the field test, laboratory measurements were made on the FM and SSB transceivers to ensure that the output powers were identical.

Along the longwall the FM and SSB medium frequency (520 kHz) transceivers provided excellent coverage. In the entryways, the SSB transceiver range was over 400 feet while the FM transceiver provided entryway coverage exceeding one mile.

The narrow-band FM modulation process is preferable for use in the underground wireless communication system.

J. ACOUSTICAL NOISE PROBLEMS

The measured acoustical noise ranges from the threshold of hearing (0.0002 Dynes/Cm<sup>2</sup>) to more than 104 dBA (158,489 times the threshold of hearing) in the reverberant surroundings of the longwall. Table J shows typical noise levels measured in the near vicinity of mining equipment (39). Noise levels of 108 dBA have been measured near mining equipment. For comparison purposes, Figure 43 shows the noise spectra measured near an operating longwall and inside of the M-60A military tank.

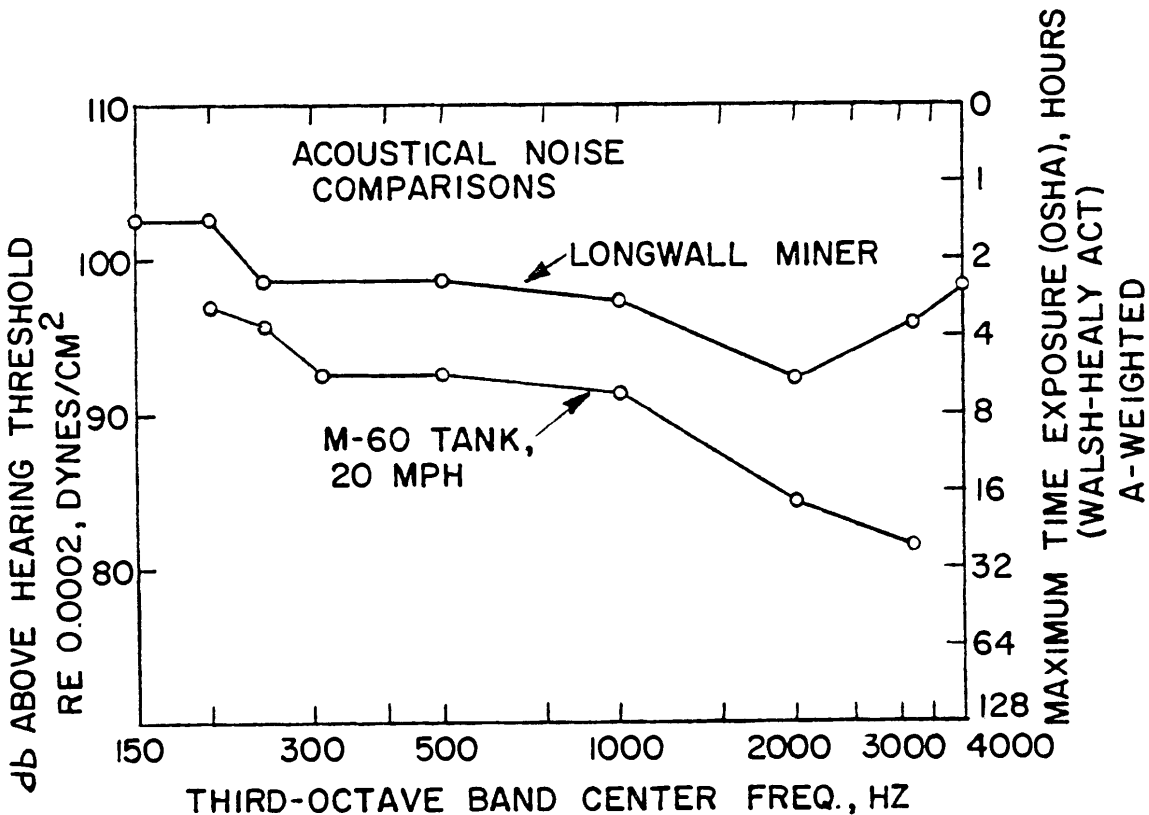

FIGURE 43. ACOUSTICAL NOISE COMPARISONS

TABLE J  
MEASURED SOUND PRESSURE LEVEL  
OF  
MINING MACHINES

| <u>MACHINE</u>             | <u>SOUND LEVEL IN dBA</u> |
|----------------------------|---------------------------|
| Diesel Powered Locomotive  | 92                        |
| Joy 10RU Cutting Machine   | 97                        |
| Wagner HMTT-410 Ram Hauler | 99                        |
| Joy Loader                 | 103                       |
| Exhaust Fan                | 103                       |
| Wagner Loader              | 106                       |
| Wagner MTT-108 Truck       | 108                       |

## 1. Overview of Microphone Noise Cancelling Theory

Comparison of the M-60A tank and longwall acoustical noise levels is noteworthy in several respects. The longwall noise level is approximately 8 dB greater than the acoustical noise level measured inside the M-60A tank! Military research indicated that intelligibility scores of voice modulated radio signals from inside of a moving tank is below the minimum acceptable limit (40). This is caused by the ambient acoustical noise mutilation of the speech pressure wave on the microphone diaphragm . By the same mechanism, voice radio communications near an operating mining equipment are expected to also be below the minimum intelligibility score.

During the early years microphones were designed using resistance responding and controlled reluctance techniques. The carbon microphone is an example of the resistance responding microphone. Controlled reluctance microphones were designed with either a coil or magnetic armature mounted on a diaphragm. The telephone headset receiver is a good example of the later technology.

Microphones have also been constructed with piezoelectric materials such as quartz, rochell salt crystals, and PZT/BaTiO ceramic materials.

In recent years, the piezoelectric properties of fluorocarbon polymers films have been investigated for using in the design of "thin" microphones.

In general microphones are broadly classified by their order. A zero (0) order microphone reproduces speech without inherent noise cancelling properties. That is, both speech and background noise cause the microphone to produce an output signal. The speech and noise pressure waves can impinge on both sides of the diaphragm. That is, the microphone responds to the pressure "difference" across the diaphragm. Microphones of this design are called first order pressure gradient microphones. First order gradient microphones can be connected in arrays to improve noise suppression and are called second order gradient microphones..

There are two (2) factors that make the gradient microphones effective in suppressing background noise. These factors are:

- (1) The "Proximity effect" whereby spherical speech pressure waves produces a greater pressure gradient across the microphone diaphragm than do planar wave noise signals which are generated at distant points.
- (2) The  $\cos \theta$  or directional response of the microphone due to acoustical access to both sides of the diaphragm and the diffraction effects of the microphone in relation to the wavelength.



Noise cancellation occurs because the phase and amplitudes of the far field noise signal sum to zero on the PZT diaphragm.

Several methods are available to obtain noise reduction in the design of a microphone. They are summarized as \*

- (1) Direction Zero (0) order microphone
- (2) Contact microphones, and
- (3) Gradient microphones.

In principal, a directional microphone will provide noise rejection. When ambient noise is a problem, these microphones have not been found to be effective in many applications.

\*Researchers have found that a microphone attached to the front tooth has exceptionally good noise cancelling properties.

First order gradient microphones are commonly available in the commercial art. Multiple order gradient microphones have superior noise cancelling properties; however, they are supercritical with respect to variations in air path length caused by lip action.

The Department of the Navy is sponsoring the development of a second order noise cancelling microphone (42). Electro voice is exploring the adaptation of the electret noise cancelling technique whereas Vought is exploring the use of PZT ceramic technology (41).

The Vought design uses a single PZT ceramic diaphragm with a specially designed acoustical entrance to obtain noise cancelling (41).

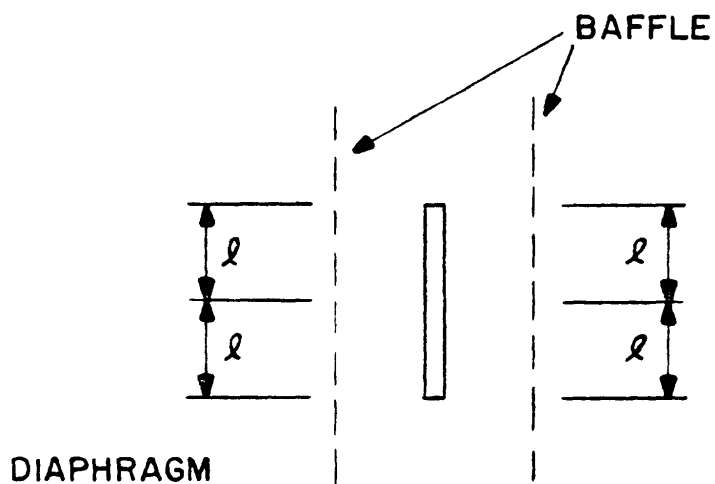

FIGURE 44. THE VOUGHT SECOND ORDER MICROPHONE TECHNIQUE

Contact microphones are sometimes called "Bone" or "Skull" microphones. Contact microphones offer little, if any, improvement in noise reduction. Further, contact microphones provide considerable discomfort to the users. It turns out, the skull bone itself becomes a conductor for noise and therefore does not inherently produce noise cancelling. Moving vehicular vibrations may be conducted through the body causing the contact microphone to respond to unwanted noise signals. The U.S. Marine Corp recently supported development work on the "skull" microphone for use in amphibian vehicles (landing craft). This work terminated when the marine radio operator complained about the microphone compression discomfort and resulting headaches. As one miner stated "How would you like to wear either the skull or throat microphone during a shift?"

First and second order gradient air path microphones do offer theoretically predictable noise cancelling possibilities.

From a circuit theory point of view, a high pass filter can be used as an analogy for the gradient microphone. Using the high pass filter analogy, the noise discrimination capability is shown in Figure 45.

---

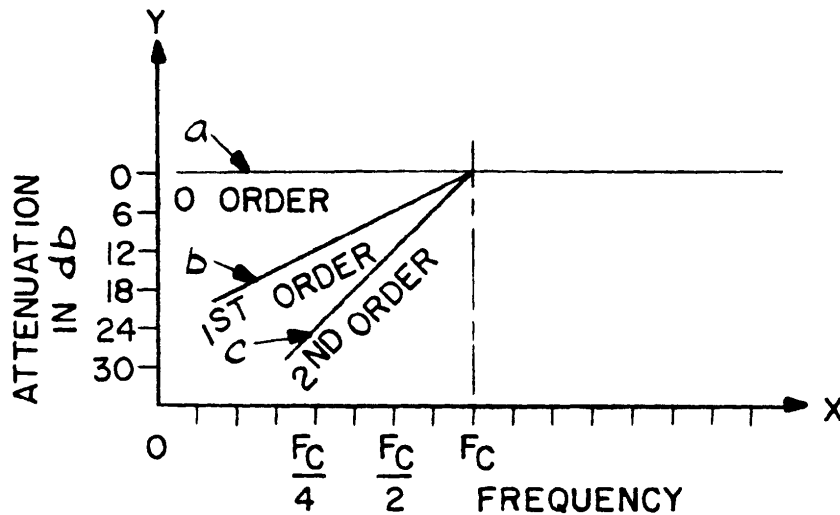

FIGURE 45. NORMALIZED NOISE FREQUENCY RESPONSE OF A GRADIENT MICROPHONE. A) VOICE SIGNAL, B) FAR FIELD NOISE, FIRST ORDER GRADIENT MICROPHONE, AND C) SECOND ORDER GRADIENT MICROPHONE.

The ordinate or y axis is labeled Attenuation in dB. The attenuation represents the noise cancelling capability of the microphone relative to a reference - curve a.

The abscissa or x axis is "scaled" or normalized in terms of the cut off frequency ( $F_c$ ) also called "cross over" frequency by microphone technologists.

The cut off frequency of the noise cancelling microphone represents the noise frequency below which cancellation occurs. Curve a represents the theoretical output signal produced by a noise cancelling microphone to spherical wave-front speech signals. In practice, the microphone response will not be flat (constant) and will exhibit considerable frequency dependence. In the case of a first order gradient microphone, the noise cancelling microphone attenuation increases by 6 dB each time the noise

frequency is halved. For a second order microphone, the attenuation increases by 12 dB for each halving of the noise frequency. In general, the asymptotic rate of attenuation is given by

$$\text{dB} = n6 \text{ per octave reduction}$$

where  $n$  is the order of the gradient microphone.

With this background, the limitation of noise attenuation can be readily assessed. First of all, if the amplitude spectrum of the noise source has principal components below the cut off frequency ( $f_c$ ), noise cancelling does occur. Also, the higher the cut off frequency, the better will be the noise cancelling attenuation for a particular noise source (same amplitude spectrum). As it turns out, the cut off frequency is dependent on the "thickness" of the microphone diaphragm. Thinner diaphragms have higher cut off frequencies and are therefore better noise cancelling microphones.

It may rightfully be concluded that higher order microphones would also be important in this application. A second order microphone design offers much greater attenuation. This conclusion may not be correct. First of all, changes in air path length occur during utterances. The apparent source position changes with lip movement (even if the microphone is stationary). Changes in air path length cause "phase" distortion to occur and this phenomenon will be described below. The instantaneous pressure for a spherical wave is given by

$$p = \frac{\rho k c A}{r} \sin k (ct - r) \quad (67)$$

where  $k = \omega/c$  is the free space propagation constant,

$c$  is the speed of sound in air,

$\omega$  is the radiant speech frequency,

$r$  is the air path length, and

$\rho$  is the air density

$$P_o = e\omega A.$$

Equation (67) may be rewritten as

$$P = \frac{P_o}{r} \sin (\omega t - kr). \quad (68)$$

The argument of the sine term includes the propagation constant ( $k$ ) and the path length ( $r$ ). Changes in path length ( $r$ ) cause changes in phase ( $kr$ ) or phase modulation. In a filter network, the non-linear phase response of the filter transfer function causes distortion to occur in the speech signal as it "flows" through the network. The "degree" of the distortion is dependent upon the type of transfer function and the asymptotic behavior of the attenuation characteristic. That is, the greater the rate of change of asymptotic attenuation in the stop band, the greater is the speech distortion. Increasing the attenuation characteristic of a microphone can be expected to increase "phase distortion" problems.

One can expect small changes in air path length to "modulate" the speech signal in higher order noise cancelling microphones.

Noise cancelling microphones are positioned to the side of the mouth to reduce the "puff" sounds.

Expanding the noise cancelling problem to speaker devices, other problems emerge. For example, a single earphone does not work well in a high level voiceband noise environment. Noise is readily transferred through the head and on the skull bone. Further, research has shown that the ear "muff" must be large to achieve low frequency attenuation. That is to say, that an ear plug speaker does not work as well as a large ear muff speaker.

The AVADT microphone and audio system study (40) is the most recent and extensive research into intelligibility scores achieved by many different types of acoustical devices in a wide range of background acoustical noise levels.

Inside of the M-60A tank, the military M-138 noise cancelling microphone is used with circum-aural earphones to achieve an intelligibility score of better than 87% (72% is the minimum acceptable limit). To attain this score, a high pass filter with cut-off frequency of 300 Hz is designed into the audio processing path. This discriminates against the lower octave noise shown in Figure 43.

In summary, the following conclusions have been reached:  
Bone and skull microphones will not be considered in  
this work.

Thin diaphragm noise cancelling microphones must be  
used in high acoustical noise areas.

A noise cancelling airpath microphone must be positioned  
on the radial line (to the side of the mouth) within a  
distance of  $\frac{1}{2}$  inch or less from the lip. This requires  
the use of a boom microphone located on the miners cap.  
A noise cancelling microphone cannot be built into the  
control head enclosure because the "apparent" microphone  
diaphragm would be thick yielding a design with a low  
cut off frequency ( $F_c$ ). The enclosure would also always  
need to be placed within  $\frac{1}{2}$  inch of the lip.

## 2. Evaluation of Noise Cancelling Microphones

The acoustical noise and its effect on voice transmission  
quality was studied in each mine. However, more extensive  
series of tests were conducted in the York Canyon Mine. The  
purpose of the tests were to evaluate various types of noise  
cancelling microphones and earphones in the underground mine  
environment. The poly (vinylidene fluoride) (PVF2) polymer  
film microphone, a military M-138 noise cancelling microphone,  
and a standard dynamic non-noise cancelling microphone were  
evaluated by voice recordings near an operating longwall.  
The voice recordings were made using ANSI phonetically  
balanced word lists. The results are shown in Table K.



TABLE K  
MEASURED  
ARTICULATION INDEX

| MICROPHONE | INTELLIGIBILITY SCORE |
|------------|-----------------------|
| Quiet Area |                       |
| Standard   | 85.3%                 |
| M-138      | 83.3%                 |
| PVF2       | 84.3%                 |
| Longwall   |                       |
| Standard   | 66.7%                 |
| M-138      | 77.7%                 |
| PVF2       | 84%                   |

Averages of the test in quiet environments show the microphone intelligibility to be very much alike. However, when subjected to higher background noise the difference becomes quite evident.

In the vicinity of an operating longwall, the "standard" non-noise cancelling microphone scored below the minimum acceptable level of 72%. Although the M-138 microphone performance was acceptable, performance degraded from the quiet value. The "thin" PVF2 microphone scored well above the M-138 microphone intelligibility score. The score did not change from the quiet area score.

### 3. Evaluation of Vest Microphones

Many different microphone configurations were evaluated during the design of the vest transceiver. A prerequisite for the microphone is that it be convenient to use and not be onerous to the miner. A hand held microphone was found to be unacceptable because the microphone cord could accidentally become entangled in mining equipment causing subsequent serious injury to the miner.

A boom microphone mounted on the miners' cap was found to be necessary in specific situations. In high acoustical noise areas, the PVF2 boom microphone and circum-aural ear cup speakers must be used to achieve an acceptable intelligibility score. The acoustical transducer mounting is illustrated in Figure 46.

FIGURE 46. PVF2 NOISE CANCELLING MICROPHONE AND CIRCUM-AURAL EAR CUP SPEAKERS MOUNTED ON THE MINERS CAP

The PVF2 boom microphone can be positioned near the miners lips. Speakers are installed in the circum-aural ear cups. Working miners expressed concern that the boom microphone would be damaged doing work. The microphone is constructed with tough plastic and survived mine testing. Evaluation in miners indicated that these acoustical transducers are required when the noise level is greater than 86 dBA.

Working miners preferred the control head microphone (shown in Figure 11) over the PVF2 boom microphone and built-in microphone in the South African Transceiver shown in Figure 30.

The control head ceramic microphone achieved an acceptable score when the noise level was less than 86 dBA. However, in fresh air entries, the ventilation air flowing across the control head produced an unacceptable level of "wind" noise.

The "wind" noise problem was solved by mounting the ceramic microphone element in acoustical wind screen foam material.

#### 4. Evaluation of Vest Speakers

When the acoustical noise exceeds 86 dBA, circum-aural earphones are required; however, these earphones may pose a safety problem in quiet areas. In quiet areas (or near idle machinery) miners are accustomed to listening to local "roof talk" caused by shifts in the layered formation. This peculiar noise may provide early warning to an experienced miner of a rock fall hazard.

A satisfactory solution to the "roof talk" problem was found by the use of a combination of vest speakers. Speakers are designed into circum-aural ear cups and the epaulets on each shoulder of the vest. The vest transceiver is designed to simultaneously drive the combination of speakers. In quiet areas, the ear cups are folded up on the miners cap and the epaulet speaker sound waves are directed upward along the miners' neck to his ears. Evaluation in the mine indicates that the geometry of the miners' cap aids in directing sound waves to the ear. Since the ears are not covered, the miner can also listen to "roof talk" when the radio is not receiving messages.

The epaulet speaker system is useful in noise levels up to 80 dBA. The vest transceiver design includes a capability of driving small earphone speakers. Earphones are useful up to noise levels of approximately 86 dB. When the noise exceeds 86 dBA, the circum-aural ear cap speakers are required.

Hard hat mounted speakers manufactured by SetCom Corporation\* were evaluated in quiet areas and on diesel haulage trucks. The speakers are shown in Figure 47.

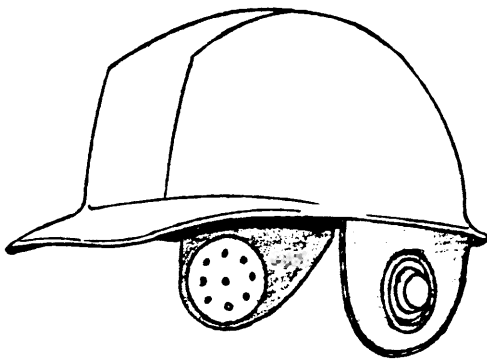

FIGURE 47. HARD HAT MOUNTED SPEAKERS

The performance was similar to the epaulet speaker system. Both fail in high noise areas.

\*SetCom Corporation, 1400 Stierlin Road, Mountain View, CA.

## 5. Evaluation of Acoustical Transducers on Mine Vehicles

Acoustical noise suppression on vehicular equipment required two different approaches. On trolley powered locomotives, the conventional practice of use of a standard hand held microphone and a remote audio head (with a loudspeaker up to 10 watts) was satisfactory. However, on diesel powered trucks and tractors (Kubota, John Deere, etc.), the conventional practice simply fails. On diesel haulage trucks, a hand-held noise cancelling microphone (M-138) and circum-aural ear cup (with speakers) was found to be satisfactory in every report. The ear cup speakers were connected to the remote audio head via a cord with a quick-disconnect connector. This enabled the motorman to get out of the truck without always remembering to unplug his earphones.

On diesel powered tractors, a handset (without noise cancelling properties) was found to be satisfactory. A hand-held noise cancelling microphone and a remote audio head with a message lamp was also satisfactory.

The mine tests indicate that a wide variety of microphones and speaker systems must be provided with a commercial radio system.

TABLE L  
 RECOMMENDED  
 MICROPHONE AND SPEAKERS  
 FOR USE IN  
 UNDERGROUND MINES

| WORK AREA OR<br>VEHICULAR EQUIPMENT                      | TYPE OF MICROPHONE<br>AND SPEAKERS  |
|--|---|
| VEST TRANSCEIVER   |   |
| Manways  | Vest control head with ceramic microphone and with epaulet speakers.                            |
| Longwall   | PVF2 noise cancelling microphone and with speakers in circum-aural ear cups.                    |
| VEHICULAR TRANSCEIVER                                    |   |
| Trolley locomotives and battery powered service vehicles | Conventional dynamic hand held microphone and remote audio speaker (10 watts)                   |
| Diesel Powered   | Noise cancelling hand-held  |
| Haulage Trucks   | Microphone with speakers in circum-aural ear cups (quick disconnect connector in speaker cord). |
| Diesel Power Tractors                                    | Noise cancelling handset with microphone and speaker. (Message light on remote speaker).        |

## K. FREQUENCY PLAN AND PRESELECTOR FILTER DESIGN REQUIREMENTS

Communication networks that will be created and used in the nations' underground mines will require the use of many operating frequencies. To avoid radio frequency interference problems in the system, specific frequencies must be assigned in accordance with a frequency plan. The goal of the plan is to insure that radio service in any network is not degraded by radio communications at any other assigned frequency whether in or out of the communications network.

The transceivers used in each network are tuned to the assigned operating frequency. The receiver and transmitter sections are designed with 60 to 1000 kHz bandwidth to eliminate the need for tuning in those sections. Tuning the transceiver only requires the setting of rocket arm switches in the digital frequency synthesizer (DFS) section. The tuning switch is shown in Figure 48.

FIGURE 48. DIGITAL FREQUENCY SYNTHESIZER TUNING ELEMENT



The switch positions for any operating frequency are given inside of transceiver enclosure. The wideband design approach simplifies field servicing. When necessary, a defective transceiver can be easily replaced with a standby transceiver. The only tuning required is the setting of the DFS switches. Because of the wideband design approach used in the radio equipment, electrical wave filter networks are required to suppress unwanted signals.

The RF line coupler and antenna are filter networks. They discriminate against unwanted signals that can cause receiver desensitization. Desensitization is caused by harmonic and spurious unwanted transmitter signals falling near or within the receiver bandwidth ( $BW_{CKT}$ ). The couplers and antennas provide adequate suppression of unwanted signals except in a few cases where additional filtering may be required.

A preselector filter is required immediately ahead of the receiver in every repeater installation. When a multiplicity of communication networks share the same wireplant conductors, the base stations associated with each network must also include a preselector filter ahead of each base station receiver. From a safety and reliability standpoint, preselector filters are recommended for use in all haulage and hoist transceivers. Except in simple frequency plans that have only one assigned frequency.

Field testing of vehicular transceivers on mine vehicles indicates that receivers are also desensitized by radio frequency interference (RFI) generated in the electrical system. RFI sources such as air compressors on trolley locomotives, DC motors on battery powered service vehicles, and generators on diesel powered vehicles produce electromagnetic spectrums in the receiver passband. Filtering at the source of RFI is mandatory.

1. Preselector Filter Network Discrimination  
Loss Specification

Sufficient isolation must be provided in the transmitter to receiver signal path to prevent receiver desensitization by high power transmitter signals.

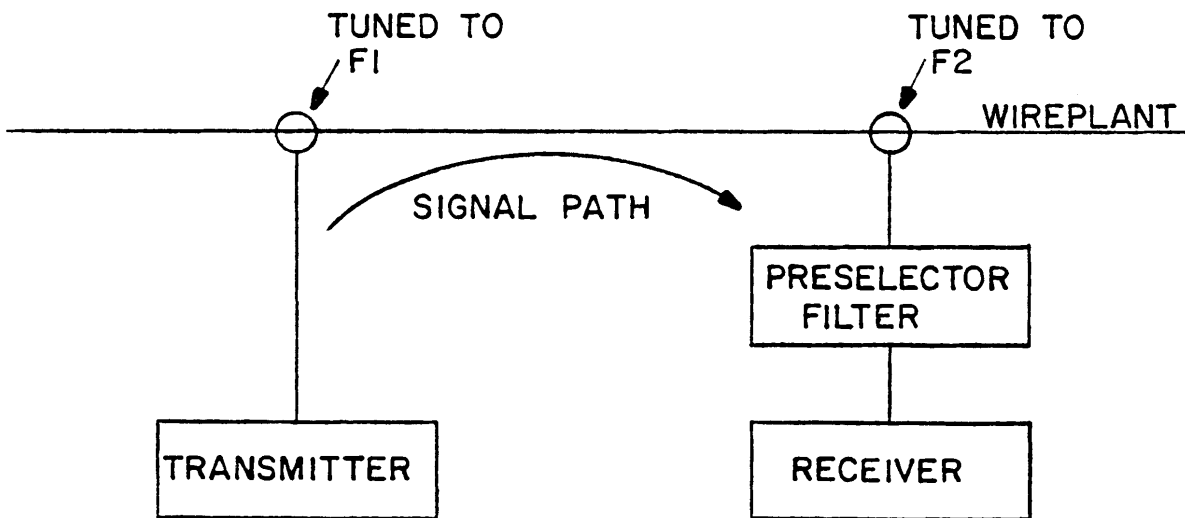

FIGURE 49. TRANSMITTER TO RECEIVER ISOLATION

The transmitter section of either a repeater or base station produces the transmit signal at the assigned frequency (F1). The signal is coupled to the "wireplant" and reaches the receiver input terminal through the RF line coupler and preselector filter. The transmitter signal discrimination loss requirements can be determined by considering the data presented in Table M.

TABLE M

SIGNAL PATH  
POWER LEVEL AND  
DISCRIMINATION LOSS

|   | <u>Transmitter Signal</u> |            |
|---|---------------------------|------------|
|   | Fundamental               | Harmonics  |
| Transmitter Output Power                      | +43 dBm                   | +30        |
| Coupling Loss                                 | -18 dB                    | -30        |
| Preselector Filter Loss                       | <u>-52 dB</u>             | <u>-70</u> |
| Level of Signal At<br>Receiver Input Terminal | -28 dBm                   | -70        |

There are two conditions under which the receiver can be desensitized by unwanted signals. First, whenever the unwanted signal reaches the receiver at a level greater than -28 dBm, the receiver RF amplifier and mixer will commence the automatic reduction of gain (compression). To avoid the loss of RF gain, the preselector filter must suppress all unwanted signals below -28 dBm. Secondly, any unwanted signal falling near or within the receiver passband will also cause receiver desensitization (capture effect). The receiver passband and selectivity is determined by a high quality crystal filter following the mixer. It is this filter that discriminates against unwanted signals with frequencies just beyond its 12 kHz passband.

As long as the unwanted signal frequencies (and harmonics) are assigned beyond 50 kHz from the receiver operating frequency, the preselector filter is required to produce a minimum discrimination loss of 52 dB.

The transient response of the preselector and IF filters determines how well the receiver will perform when near electrical noise sources. Impulsive electromagnetic noise sources such as trolley "shoe" arcing and the discontinuous trolley rectifier current waveform may cause the filters to ring. Ring degrades receiver performance. Ring degradation may be reduced in the design by appropriate filtering techniques.

The principal technique is the selection of a filter transfer function with minimum ring behavior. Transfer function that exhibits more linear phase response through the passband region exhibit less ring.

A class of transfer functions including the Bessel and Gaussian exhibit minimal ring; however, the stopband discrimination loss is always less than other classes of transfer functions of the same order (N).

Transfer functions that exhibit good passband phase characteristics and still achieve acceptable stopband discrimination loss are derived from the Butterworth and Legendre polynomials of mathematical physics. Chebyshev transfer functions are optimum in the sense that they produce the maximum stopband discrimination loss; however, the phase response is always less desirable than either the Butterworth or Legendre transfer functions. The Legendre transfer functions are optimum in the sense that they exhibit minimum ripple in the passband. They produce considerable more stopband discrimination loss than Butterworth (43)(44)(45). The Legendre transfer functions are useful in application which requires good discrimination loss as well as good phase linearity and transient response behavior. Legendre filters are recommended for use in narrowband angle modulated communications systems.

The discriminations loss of well known transfer functions are shown in Figure 50.

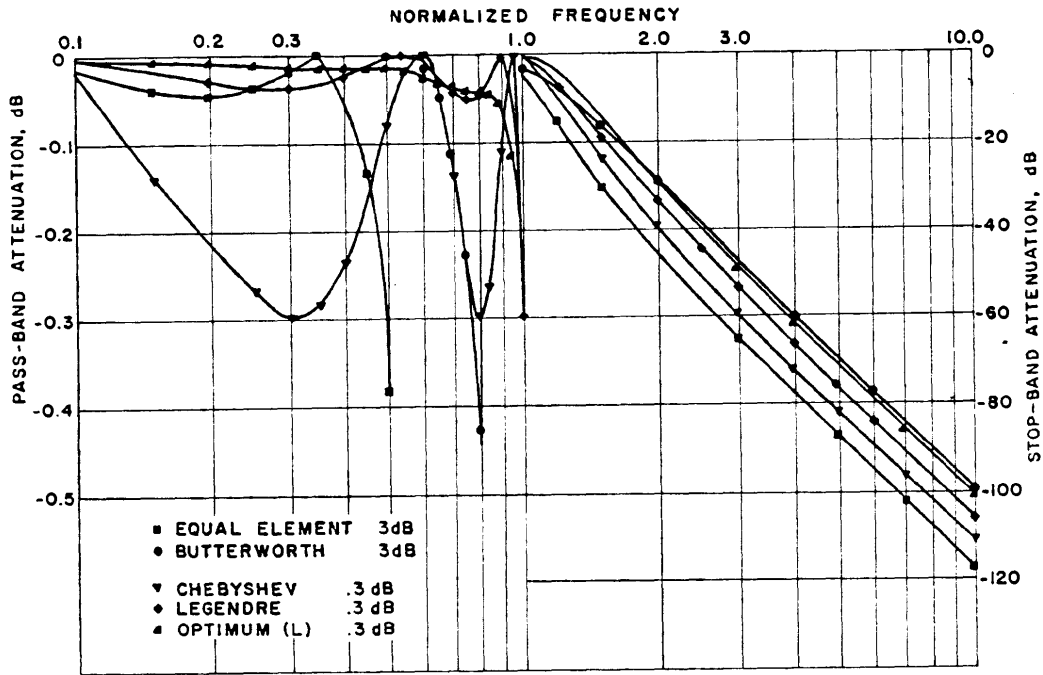

FIGURE 50. COMPARISON OF THE DISCRIMINATION LOSS OF WELL KNOWN TRANSFER FUNCTIONS (5TH ORDER)

## 2. Calculating The Discrimination Loss of Bandpass Filter Networks

The operating frequency ( $f_o$ ) and circuit bandwidth ( $BW_{CKT}$ ) are always known in the initial stages of specifying the filter discrimination loss requirement.

The circuit bandwidth defines the passband region of the filter where the discrimination loss is always less than  $\frac{1}{2}$ , 1, ... 3, dB, etc. Other bandwidths are always specified in a filter design problem. For example, the 60 dB bandwidth ( $BW_{60}$ ) defines the bandwidth where the loss is always less than 60 dB. The lower and upper bandedge frequencies can be calculated using the following equations.

The bandwidth is defined as

$$BW_D = f_H - f_L \quad (69)$$

when D represents the dissipation loss value,

$f_H$  the upper bandedge frequency, and

$f_L$  the lower bandedge frequency.

The bandedge frequencies are given by

$$f_H = \frac{BW_D}{2} + \sqrt{\frac{BW_D^2}{4} + f_o^2} \quad \text{and} \quad (70)$$
$$f_L = \frac{f_o^2}{f_H}$$

The discrimination loss provided by a filter network at the bandedge frequencies can be determined from the data presented in Appendix A.

In the tables, discrimination (normalized attenuation) loss of the Legendre filter transfer function are given for different filter orders (N). The normalized frequency ( $\Omega_{LP}$ ) used in the table can be simply calculated from

$$\Omega_{LP} = \frac{BW_D}{BW_{CKT}} \quad (71)$$

The filter order (N) represents the number of reactive elements required in the low pass prototype network. By well known frequency transformations, prototype networks are transformed into bandpass as well as other frequency response characteristics such as low pass, high pass and band elimination.

### 3. Discrimination Loss of Couplers and Antenna Filter Networks

The discrimination loss encountered by the transmitting frequency signal in the receiving couplers (also antennas) will be determined from the tabular data. This is the value of coupling loss shown in Table L.



The coupler (antenna) 3 dB design bandwidth ( $BW_3$ ) is 12 kHz. The 100 kHz bandedge frequency for a coupler (antenna) operating at 400 kHz may be calculated from Equation (69) and (70) as

$$f_H = 453.1 \text{ kHz, and}$$

$$f_L = 353.1 \text{ kHz.}$$

It should be noted that these frequencies are slightly skewed because of geometric symmetry in the loss characteristic. Referring to Appendix A (N=1 data), at a normalized frequency given by

$$\Omega_{LP} = \frac{100 \text{ kHz}}{12 \text{ kHz}} = 8.3, \quad (72)$$

the discrimination (normalized attenuation) loss is found to be 18.3 dB for all frequencies outside of the 100 kHz bandwidth. This loss is identified as coupling loss in Table L.

#### 4. Discrimination and Dissipation Loss of The Preselector Network

The required preselector filter order (N) may be determined from the Appendix A data. A 3rd order filter can provide 62.8 dB of discrimination loss. Thus a 3rd order filter design is required. Preselector filters exhibit signal dissipation loss at the center frequency. This loss can be determined from Appendix B data.

In the Appendix B data, the table element  $Q(Q_{LP})$  is defined by

$$Q_{LP} = \frac{Q_u}{Q_{CKT}} \quad (73)$$

where  $Q_u$  is the unloaded  $Q$  of the inductors used in the filter (measured at  $f_o$ ).

In the MF band,  $Q_u$ 's are typically greater than 250 in a well designed inductor. Thus with

$$Q_{LP} = \frac{250}{33} \doteq 7.5,$$

the band center dissipation loss is estimated to be less than 3 dB.

#### 5. Designing Filter Networks

The design data for Legendre filters has been included in Appendix C. The element values are given for a normalized low pass prototype filter that has a cut-off frequency ( $\Omega$ ) of one radian per second and equal load and source termination resistances of one ohm.

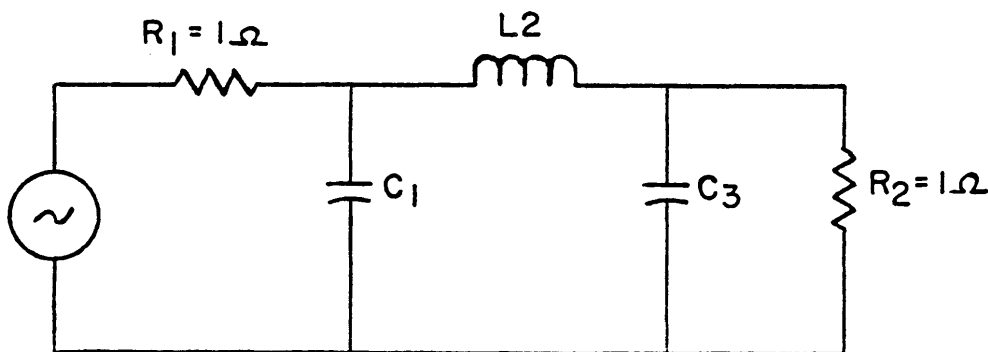

FIGURE 51. LOW PASS PROTOTYPE FILTER

This particular normalization of filter element values make the design of actual filters as simple as pie ( $\pi$ ).

a. Designing Low Pass Filters

The actual low pass filter element values are given by

$$\bar{L} = \frac{LR}{2\pi f_c} \quad \text{and,} \quad (74)$$

$$\bar{C} = \frac{C}{2\pi f_c R} \quad (75)$$

where  $f_c$  is the cut-off frequency, and C and L are the low pass prototype element values.

Equations (74) and (75) tell us a great deal about a filter network. First of all, increasing the cut-off frequency always reduces the size of the actual element values. Secondly, the terminating (source and load) resistances influence the size of the actual element values in different ways. Increasing the termination resistance increases the inductance values while decreasing the capacitance values in the actual network. The topology of the low pass network is invariant in the design of an actual low pass filter.

The dissipation loss of the low pass filter network is determined with the use of the table in Appendix B - Dissipation Loss of the Legendre Transfer Function.

The Q of each inductor used in the filter network is measured with a Q meter at the cut-off frequency of the filter. The Q may also be determined from data supplied by the inductor manufacturer.

For example, a  $Q_U$  of 250 is easily realizable in a low pass filter with a cut-off frequency of 100 kHz. The zero frequency insertion loss in a third order low pass Legendre filter is 0.09 dB.

b. Designing A High Pass Filter From a Low Pass Prototype Network

The first step required is to redraw the low pass prototype filter such that the inductors become capacitors and capacitors become inductors with inverted values. The redrawn filter is a high pass prototype filter with a cut-off frequency of one radian per second. The actual low pass filter element values are calculated from the redrawn filter. Use Equations (72) and (73) to calculate the element values of this filter.

c. Designing Bandpass Filters From Low Pass Prototype Filters

Bandpass filters are designed from the low pass prototype filter element values by use of the following frequency transformations:

$$\Omega_{LP} = \frac{\omega_1 \omega_2 - \omega^2}{\omega(\omega_1 - \omega_2)} \quad (76)$$

The mechanics of the frequency transformation are simply carried out by dividing each inductance and capacitance in the low pass prototype filter by the bandwidth (in Hertz) of the band-pass filter (instead of the cut-off frequency as was the case in the low pass filter denormalization process) and resonating each of the filter elements at the center frequency of the filter. That is

$$\bar{C} = \frac{C}{2\pi BW_{CKT} R} \quad \text{and} \quad \bar{L} = \frac{1}{(2\pi f_o)^2 \bar{C}} \quad (77)$$

$$\bar{L} = \frac{LR}{2\pi BW_{CKT}} \quad \text{and} \quad \bar{C} = \frac{1}{(2\pi f_o)^2 \bar{L}} \quad (78)$$

where  $BW_{CKT}$  is the bandpass filter bandwidth and  $f_o$  is the center frequency. Equations (77) and (78) provide a great deal of insight into the design characteristics of a band-pass filter.

The low pass prototype elements are changed by dividing by the circuit bandwidth of the actual filter. These filter elements increase in value as the filter bandwidth is decreased. Thus the series inductors and shunt capacitors in the bandpass network always increase in value when the circuit bandwidth ( $BW_{CKT}$ ) is reduced. Further, these elements are influenced by the filter termination resistance as defined in Equation (77) and (78).

In many practical filter design problems, the "spread" in filter element values may be too great. Impedance levels within the filter can be changed by alternating operating impedance levels ( $R$ ) within the network as indicated by Equations (77) and (78).

The dissipation loss (insertion loss) at the band center ( $f_0$ ) of a bandpass filter is also easily and accurately determined with the use of Appendix B. Equation (75) is used to determine  $Q_{LP}$ .

d. Designing Band-Elimination Filter Networks From Low Pass Prototype Filter Networks

Band-elimination filters are designed from low pass prototype filters by first constructing a high pass prototype network and then finding the actual element values ( $\bar{L}$  and  $\bar{C}$ ) by using Equations (75) and (76).

e. Determination of the Discrimination Loss of Actual Bandpass and Band-Elimination Filters From the Discrimination Loss of a Low Pass Prototype Filter

The discrimination loss of the low pass Legendre prototype filters orders ( $n=1,2,\dots,9$ ) are shown in Appendix A.

Figures 52 and 53 show the discrimination loss plotted for odd order filters. A noteworthy feature is the fact that the frequency scale ( $f$ ) is normalized by the circuit bandwidth ( $BW_{CKT}$ ). Similarly, the low pass or high pass prototype filter elements are de-normalized by dividing by ( $BW_{CKT}$ ) to find the actual filter element values. This necessarily follows from Equation (74).

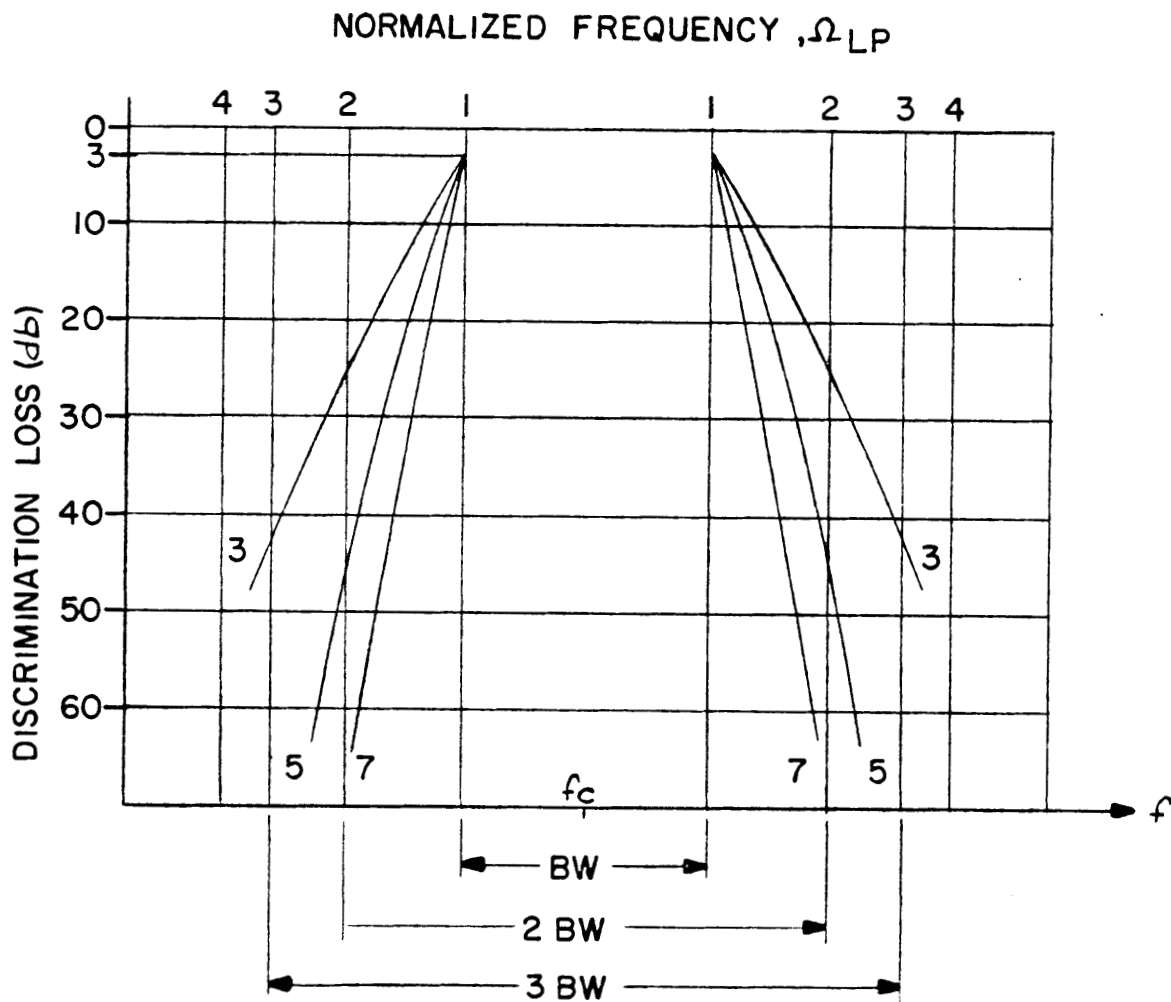

FIGURE 52. LEGENDRE BAND PASS FILTER DISCRIMINATION LOSS FOR ORDERS  $n= 3,5, \text{ and } 7$

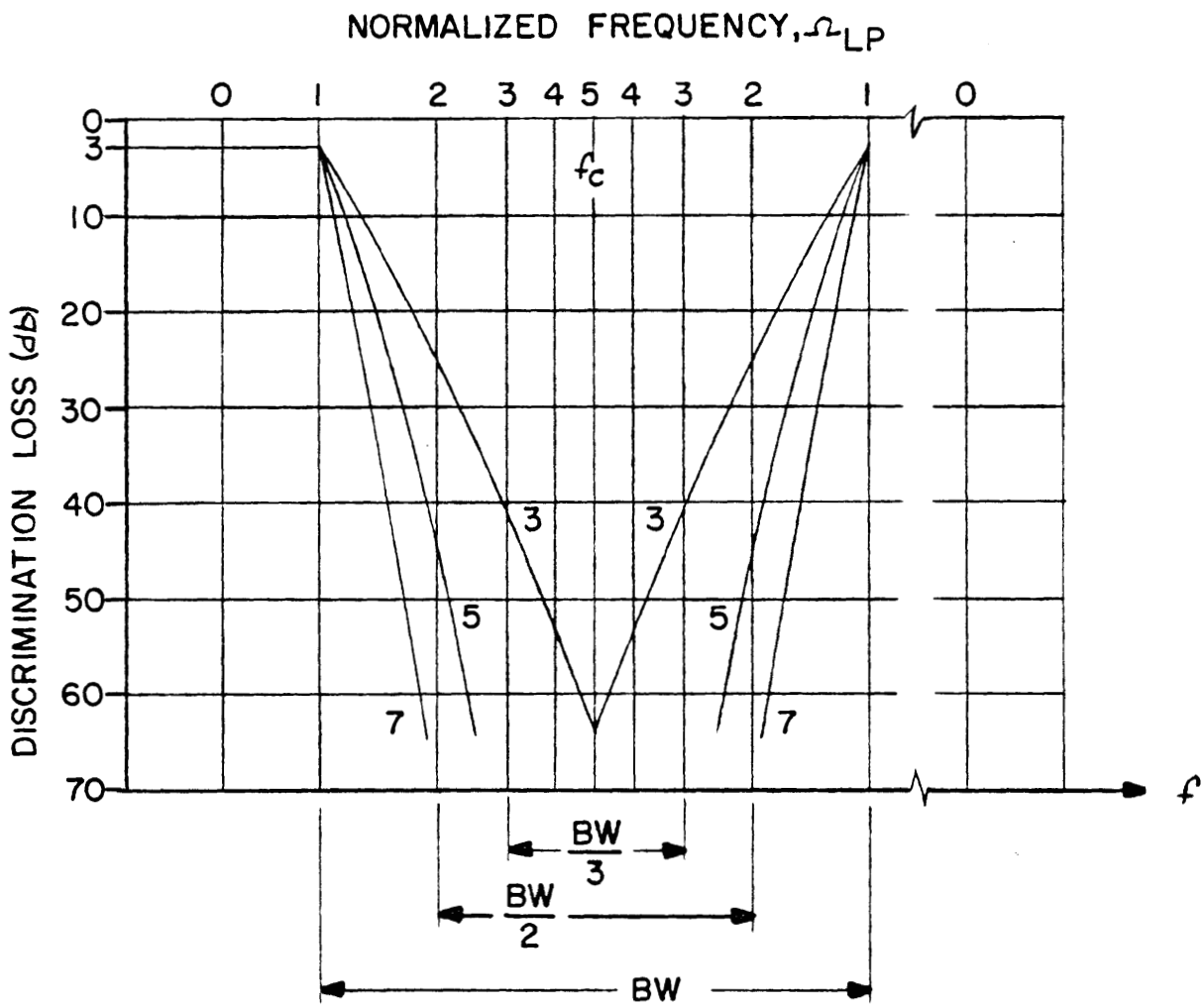

FIGURE 53. LEGENDRE BAND ELIMINATION FILTER DISCRIMINATION LOSS FOR ORDERS  $n=3, 5, \text{ and } 7$



The figures also show the direct relationship between the low pass prototype normalized frequency ( $\Omega_{LP}$ ) and circuit bandwidth ( $BW_{CKT}$ ).

The discrimination loss characteristic can be plotted on multiple cycle semi log graph paper. The y axis is labeled in discrimination loss (dB) and the x axis is labeled in units of operating frequency.

## V. SYSTEM DESIGN SPECIFICATIONS

### A. SUMMARY

The design doctrine for the whole mine radio communications system includes the system level specifications as well as the flowdown specifications for the equipment and module level printed circuit boards. To insure interface compatibility throughout the system, standardized interconnecting loads and levels have been strictly adhered to in the design practice.

The theoretical basis for the design specifications follows from discussions set forth in Chapter IV.

### B. INTRODUCTION

The equipment used in the MF radio communications system consists of:

- . Remote Control Console (RCC) and Remote Control Terminal (RCT) units to operate a multiplicity of fixed location and mobile transceivers in an underground mine.
- . A base station comprising a standard transceiver and RCT unit for creating a cell of radio coverage.
- . A vehicular transceiver comprising a standard transceiver and Remote Audio Head (RAH) unit for communications on mobile platforms.

- . Vest transceiver for communications with roving miners.
- . Global repeater to increase the operating range between mobile transceivers along the "wireplant".
- . Cellular repeater to illuminate a working face.
- . Highly efficient RF line couplers and antennas to "illuminate" the "wireplant".

A cell of radio coverage is created by installing an RCC unit(s) in the network "nerve" center(s). The base station is remotely controlled by a two-wire remote control (RC) cable. The RCC unit can remotely control fixed location base station and repeater transceivers for distances greater than five miles. Additional networks are created by installing separate network RCC units, RC cables, and base stations.

#### C. GENERAL SYSTEM SPECIFICATIONS

The general system specifications set forth the principal design objectives for the equipment. Equipment designed to these specifications will achieve excellent radio coverage in the mining complex. The equipment will also exhibit extremely high reliability when operating in the hostile mine environment. Strict adherence with the equipment interconnection (interface) specifications will insure a degree of compatibility among radio equipment deployed in the Nation's underground mines.

1. SIGNAL EMISSIONS:

|                                   |                            |
|-----------------------------------|----------------------------|
| Type                              | Narrow band FM             |
| Emission                          | 10F3                       |
| Frequency Range                   | 60 kHz to 1000 kHz         |
| Tuning                            | 5 kHz increments           |
| Peak Deviation                    | 2.5 kHz                    |
| Frequency Separation              | 50 kHz (min) for repeaters |
| National Rescue Team<br>Frequency | 400 kHz                    |

2. MODULATION:

|                    |  |
|--------------------|--|
| Processing (voice) | Enhanced average voice signal processing |
| Frequency Range    | 200 to 2500 Hz (3 dB BW)                 |

3. SQUELCH:

|      |   |
|------|---|
| Type | Two (2) alternate types of squelch control:<br>Noise Operated Squelch, and<br>Tone Operated Squelch |
|------|---|

|   |  |
|---|--|
| 4. <u>SIGNALLING TONE<br/>FREQUENCY</u> | 100 Hz + 20 Hz for subaudible tone<br>1000 Hz + 100 Hz for inband signalling |
|---|--|

|                            |   |
|----------------------------|---|
| 5. <u>OPERATING RANGE:</u> | 200 to 400 meters (in coal quasi-free conductor area)<br>20,000 feet 1.5 meters from wireplant conductors |
|----------------------------|---|

6. ENVIRONMENTAL:

|                             |   |
|-----------------------------|---|
| Operating Temperature Range | -20 to 60 degrees c.                        |
| Shock (Drop)                | 4 feet onto soft pine board 2 inches thick. |
| Dust                        | Dust Resistant                              |

|  |   |
|--|---|
| Special Condition                                      | Withstand sulfide ore body ground water drip  |
| Vibration  | 0.045 inches P-P amplitude vibration<br>10 to 55 Hz   |
| 7. <u>CONSTRUCTION:</u>                                | Sealed Stainless Steel enclosures<br>Activated Desiccant per Mil-D-3464D<br>Interior protected with vapor corrosive inhibitors<br>Use of aluminum is prohibited<br>Humiseal coated printed circuit boards |
| 8. <u>STANDARIZED INTERCONNECTION LOADS AND LEVELS</u> |   |
| RF Signal  |   |
| Load Impedance   | 50 ohm load plane   |
| Remote Control Cable                                   |   |
| Load Impedance   | 300 ohms (Twin lead cable)  |
| Audio Interface  |   |
| Load Impedance   | 600 ohms  |
| Level for rated output                                 | 0 dBm   |
| Squelch Flag   | <u>Sq Flag</u> (1)  |
| Unsquelled   | Less than 0.7 V DC  |
| Squelched  | More than 7 V DC  |
| Key Transmitter Command (PTT)                          | <u>Trans Key</u> (1)<br>Less than 0.7 V DC  |
| Tuning Command   | <u>F1 → F2 Trans</u> (1)<br>Less than 0.7 V DC  |
| RCC Unit   | <u>DC Comd</u>  |
| DC Command   | More than 7 V DC into 300 ohms  |
| Tone   | More than 4 V rm into 300 ohms  |

(1) Underlined Command Symbol indicates that signal must go low (sink 100 MA of current).

9. PERMISSIBILITY Vest per UL 913 and MSHA CFR,  
Title 30, Part 23

10. CABLING & CONNECTORS

|                                    |  |
|------------------------------------|--|
| Remote Control<br>(RC) Cable       | 2 Conductors                               |
| RF Signal<br>(RS) Cable            | 3 Conductors (1) Type S0 with<br>Connector |
| Remote Control Head<br>(RCH) Cable | 7 Conductors (1) Type S0 with<br>Connector |
| 12 V DC Power Cable                | 2 Conductors (1) Type S0 with<br>Connector |

11. Vehicular Transceiver  
Hazard Prevention Every metal transceiver enclosure  
must be grounded to vehicle frame  
ground.

Vehicular Transceiver  
Power Supply Installation of a transceiver on  
vehicles with floating primary  
battery sources and DC motors  
requires mandatory use of isolated  
DC to DC converter to supply  
power to the transceiver.

(1) One conductor to be attached to frame ground.

#### D. BASE STATION AND VEHICULAR TRANSCEIVER SPECIFICATIONS

The electrical specifications for the fixed location base station and mobile vehicular transceiver are identical. They both use the same standard transceiver enclosure. This greatly simplifies maintenance training and repair activities because the maintenance man only needs to become familiar with one transceiver design.

Remote Audio Head (RAH) permits a standard transceiver to be installed on all vehicles used in the mining process. The RAH is mounted on the vehicle in a physical location that is convenient for motormen usage. The RAH uses a Remote Control Head (RCH) cable to interface with the transceiver.

A Remote Control Terminal (RCT) unit permits the standard transceiver to operate as a base station. The RCT unit is mounted on the rib next to the transceiver. The RCT unit also uses the RCH cable to interface with the transceiver. Thus, both the RAH and RCT are plug compatible with the transceiver. The remote control (RC) cable interfacing the "nerve" center RCC connects directly to the RCT unit.

The electrical specifications for the transceiver are shown in Table N. The block diagrams of the equipment are described in the following sections.

## 1. Standard Transceiver

The transceiver specifications are given in Table N . The block diagram is illustrated in Figure 54 . The control board (A11) is the mother board for the receiver (A1), synthesizer (A2), exciter (A3) and RF power amplifier (A4) printed circuit modules. This board determines the operational characteristics of the transceiver (1).

(1) A similar board (A11R) is used to construct a repeater transceiver.



TABLE N  
STANDARD  
TRANSCEIVER SPECIFICATIONS

USE: Universal transceiver for use as either a base station or vehicular transceiver.

OUTPUT POWER: 1 to 20 Watts (adjustable)

RF OUTPUT LOAD: Optimized to drive loop antenna, 200 ohm transmission line or RF line coupler.

POWER REQUIREMENTS:

Operating Voltage Range 11 to 15 VDC

Demand Current

Receiving Standby 35 mA (max)

Receiving Audio 300 mA (max)

Transmit 3.5 Amperes

ELECTRICAL SPECIFICATIONS:

Receiver A1 Specifications

Synthesizer A2 Specifications

Exciter A3 Specifications

Transmitter A4 Specifications

Audio Power Amplifier A5 Specifications

CONNECTORS:

|   | PIN |
|---|-----|
| RF Signal   |     |
| RF Output   | 1   |
| Frame Ground  | 2   |
| F1→F2 (Trans)                                       | 3   |
| 12 V DC Power (1) (2)<br>(base station application) |     |
| 12 V DC   | 1   |
| Ground  | 2   |
| Remote Control Head                                 |     |
| <u>SQ Flag</u>                                      | 7   |
| <u>F1→F2 (trans)</u>                                | 6   |
| Audio Output (A1)                                   | 5   |
| Audio Input (A2)                                    | 4   |
| <u>Trans Key</u>                                    | 3   |
| 12 V DC   | 2   |
| Frame Ground  | 1   |

(1) Enclosure hardware grounded to Pin 2.

(2) 12 V DC power supplied through Remote Control Head connector in base station application.

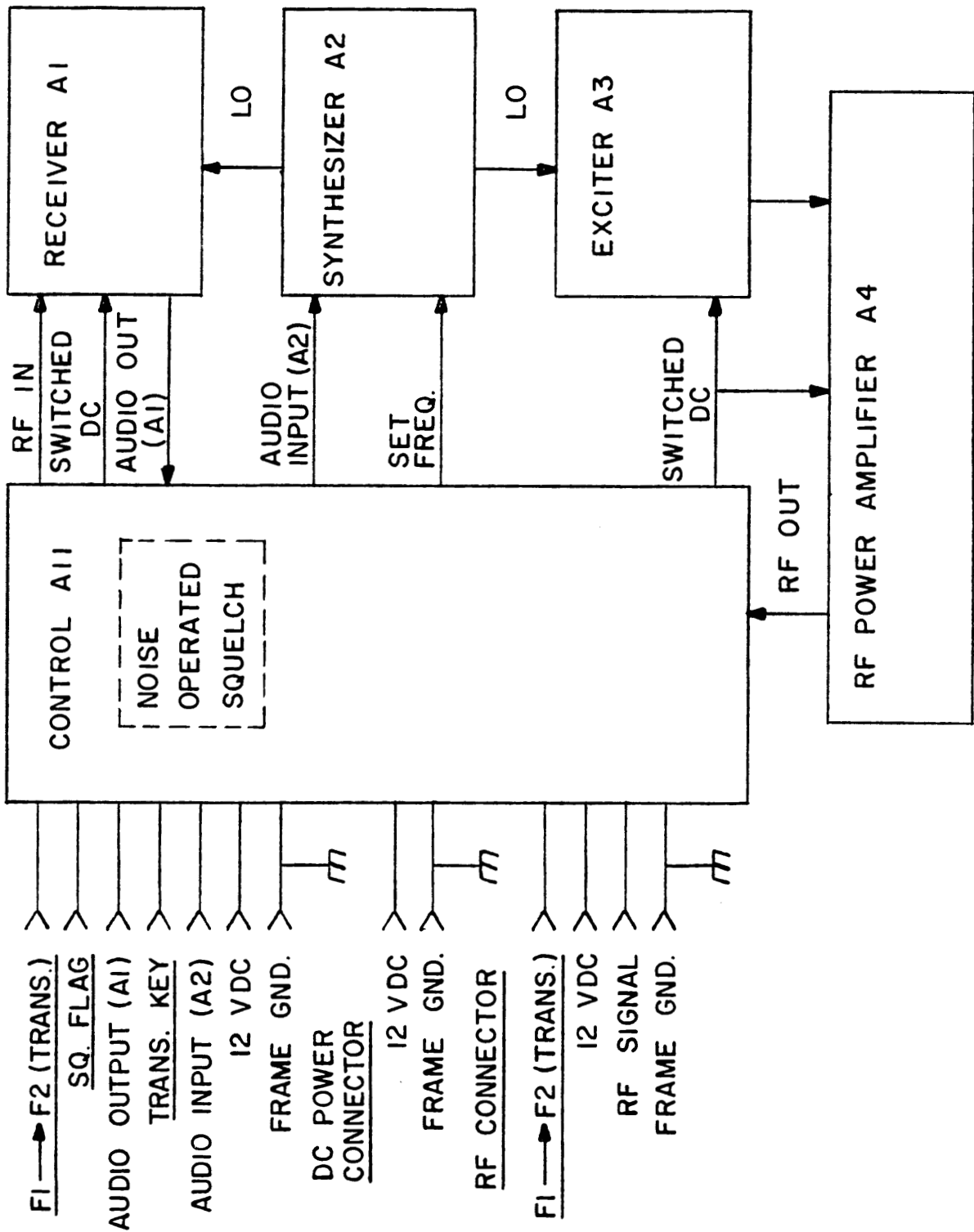

FIGURE 54 BASE STATION AND VEHICULAR TRANSCEIVER BLOCK DIAGRAM

Recovered audio signals (audio out-A1) from the receiver (A1) are applied to the noise operated squelch network on the Control Board (A11). Audio signals (audio input-A2) from the microphone are connected through printed circuit wiring on the A11 board to the input terminal of the signal processor network on the synthesizer board (A2). After processing, the audio signal modulates the digital synthesizer local oscillator (L0) output signal frequency.

The power connector is used to source DC supply voltage to the transceiver. The microphone push to talk (PTT) switch generates a standard transmitter key command. The Trans Key command turns on the transmitter by switching on the DC supply voltage to the RF power amplifier (A4) and turns off the receiver (A1) by switching off the receiver DC supply voltage.

The standard transmit frequency select command F1→F2 (Trans) causes the A11 board to generate a digital binary frequency code to tune the synthesizer to the frequency F2. In the absence of F1→F2 (Trans) command, the synthesizer is always tuned to the frequency F1.

The transmit frequency select command F1→F2 (Trans) also appears at the RF connector and is used to tune either the antenna or coupler to the frequency F2.

The noise operated squelch network generates the standard squelch flag (SQ Flag) signal.

The All board uses relay switching to direct RF signals to the receiver in the receiving mode and to send RF power amplifier signals to the RF signal connector.

The Remote Control Head (RCH), 12 V DC power and RF signal connectors are located on the enclosure.

## 2. Remote Control Terminal (RCT) unit

The specifications are shown in Table 0 . Figure 55 illustrates the block diagram of Remote Control Terminal (RCT) unit. The RCT unit is used when the standard transceiver is operated as a base station. The RC cable is connected to the RCT unit line matching transformer terminals. The transformers are designed to cancel unwanted common mode signals and pass legitimate differential mode signals. The legitimate signals are:

- Audio baseband (voice) signals,
- DC command signals, and
- Subaudible control signals.

TABLE 0

REMOTE CONTROL TERMINAL (RCT)  
SPECIFICATIONS

USE: Used with standard transceivers and repeaters to provide remote control capabilities from the remote control console unit.

STANDARD LOADS:

|                   |          |
|-------------------|----------|
| RC Cable          | 300 ohm  |
| Transceiver Audio | 600 ohms |

AC POWER SOURCE:

|    |          |
|----|----------|
| AC | 117 V AC |
|----|----------|

DC OUTPUT:

|                   |                     |
|-------------------|---------------------|
| Operating Voltage | 12 to 14 V DC       |
| Regulation        | $\pm 2\%$           |
| Over Shoot        | Max voltage 16 V DC |

DEMAND CURRENT

|                   |                          |
|-------------------|--------------------------|
| Receiving Standby | 40 mA (min)              |
| Transmit          | 4.0 amperes              |
| Standby Battery   | Lead Acid, 5 AH capacity |

CONNECTORS:

|                        |              |
|------------------------|--------------|
| RC Cable               | Type         |
| Remote Control Head    |              |
| <u>SQ Flag</u>         | Pin NO.<br>7 |
| <u>F1 → F2 (Trans)</u> | 6            |
| Audio Output (A1)      | 5            |
| Audio Input (A2)       | 4            |

|                  |   |
|------------------|---|
| <u>Trans Key</u> | 3 |
| 12 V DC          | 2 |
| Frame Ground     | 1 |

ENCLOSURE: Sealed Enclosure

SIGNALLING:

Remote Control Socket

RC Cable

SQ Flag

DC Comd

0 dB Audio Output (A1)

3 V AC (RMS)

Trans Key

DC Comd (3 V DC min)

F1 → F2 (Trans)

100 Hz signal  
1/2 V AC rms (min)

Audio Input (A1)

0 dBM

1 V AC rms

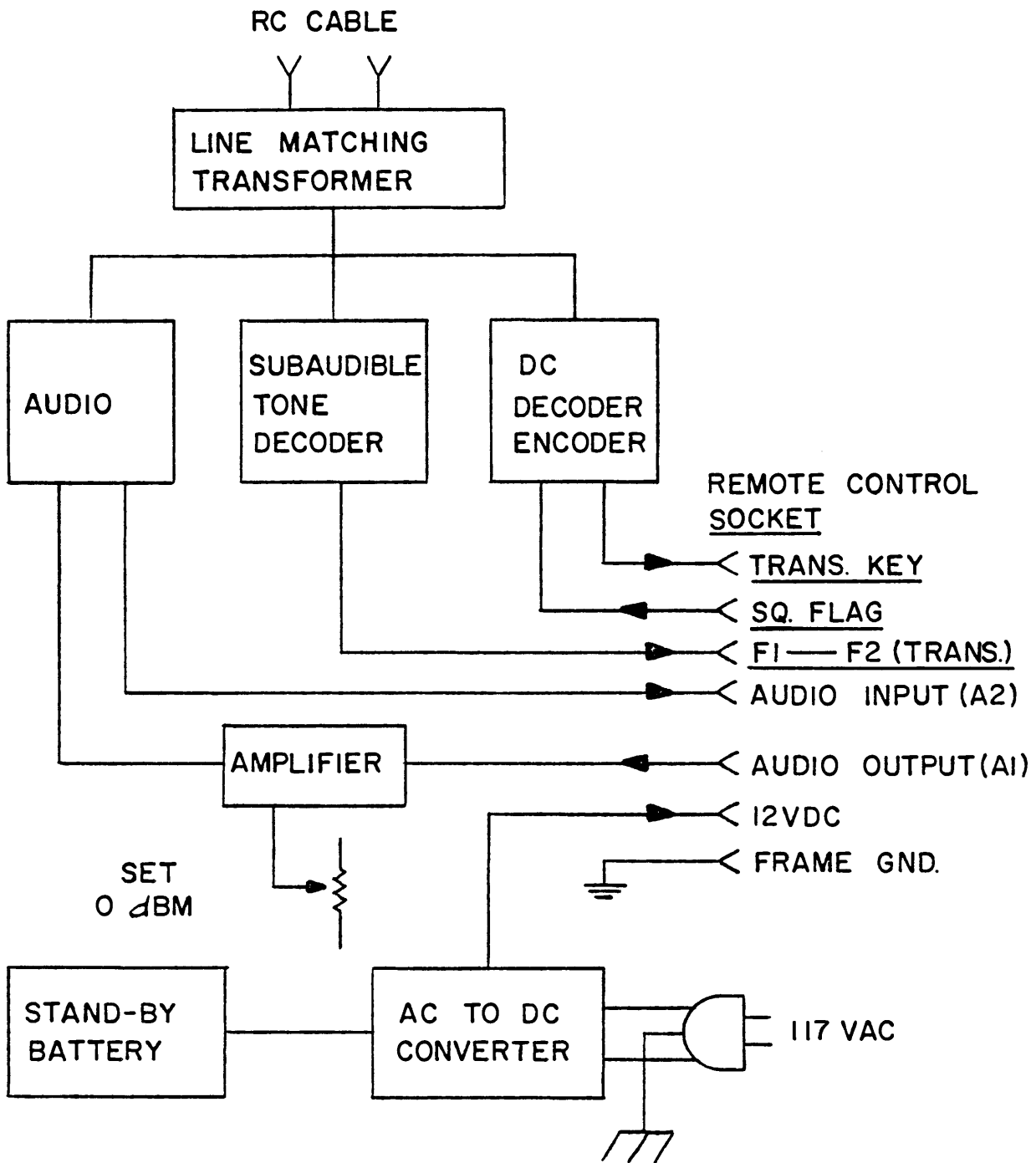

FIGURE 55 BLOCK DIAGRAM REMOTE CONTROL TERMINAL (RCT) UNIT



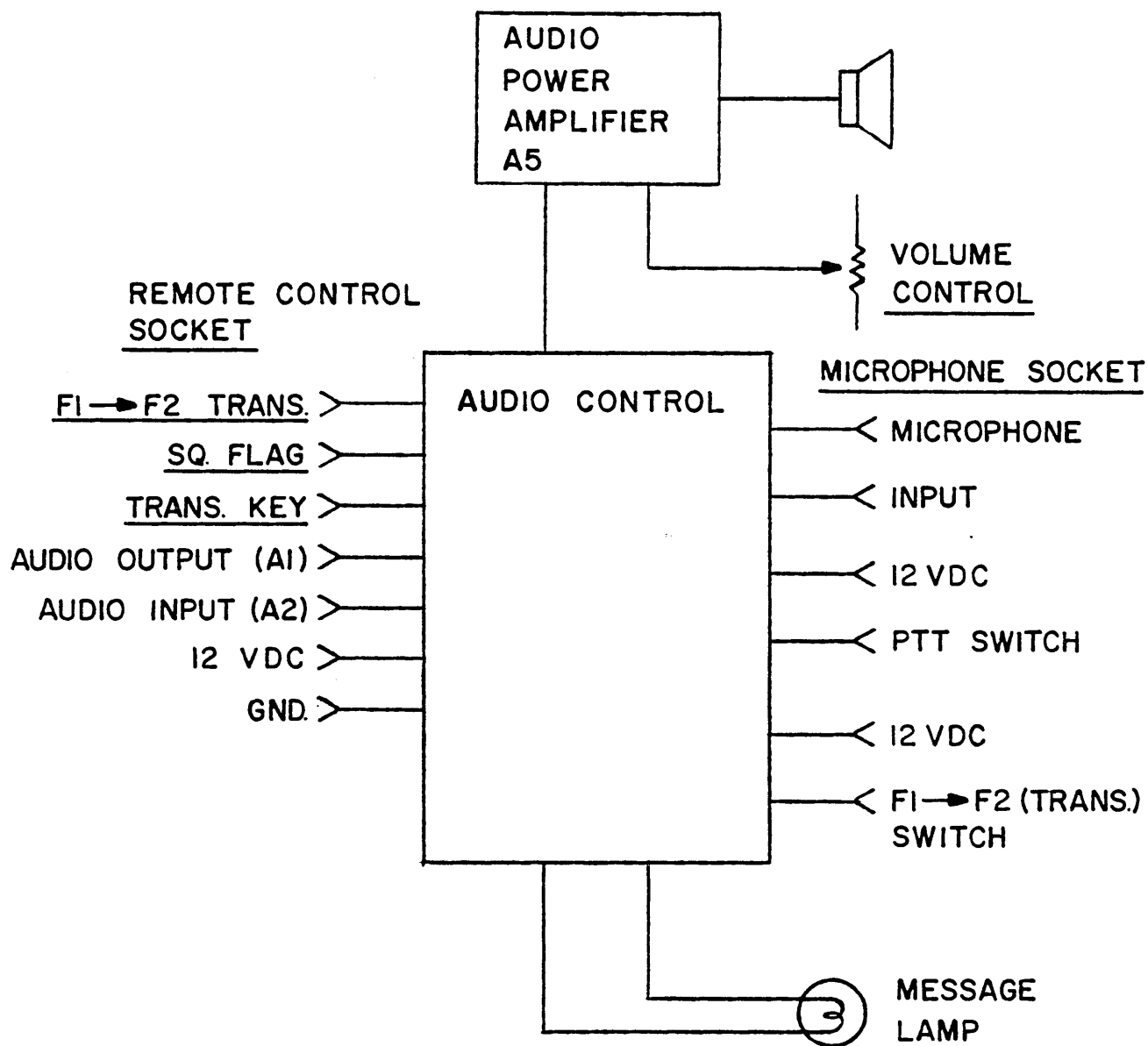

FIGURE 56 REMOTE AUDIO HEAD (RAH) BLOCK DIAGRAM

Any RC cable DC command signal is detected by the DC decoder. The decoder generates the Trans Key command, keying base station transmissions at the frequency (F1). Any transceiver squelch flag command (SQ Flag) causes the DC encoder to generate a DC command signal (DC Comd) and apply it to the RC cable. This allows the base station to key any other base stations (or repeaters) in the network as well as enabling the "nerve" centers RCC units to receive audio base band messages recovered in the base station receiver. Any subaudible tone on the RC cable is decoded generating the F1→F2 (Trans) command. This permits the RCC unit to remotely switch the base station to the transmit frequency (F2). The base station can acquire any global repeater in this mode operation. Any RCC unit can be used to talk through a stand alone global repeater to an out of range mobile transceiver.

The RCT unit includes the AC to DC converter and stand-by battery for the base station.

### 3. Remote Audio Head (RAH)

The specifications are shown in Table P . Figure 56 illustrates the RAH block diagram.

The Audio Power Amplifier (A5) is controlled by the SQ Flag command. The amplifier is turned on when the transceiver is unsquelched by a received radio signal. The message lamp also turns on, signalling the motorman of a message.

Microphone audio input signals are transferred directly to the remote control socket. PTT switch signals become Trans Key commands.

The F1/F2 switch position F2 generates the F1→F2 (Trans) command.

The RAH is enclosed in a sealed box. It obtains its DC supply voltage from the transceiver.

TABLE P

REMOTE CONTROL HEAD (RCH)  
SPECIFICATIONS

USE: Used with standard transceiver to allow convenient transceiver operation by motorman.

STANDARD LOADS:

Transceiver Audio 600 ohms

DC SUPPLY:

Operating Voltage 12 V DC

Demand Current

Standby 5 mA (min)

Full Audio 250 mA (max)

CONTROLS:

Audio Output Level Volume Control

Push to Talk On Microphone

F1 → F2 (Trans) SPDT Switch

CONNECTORS:

Microphone Pins

Microphone 1

Ground 2

PTT Switch 3

REMOTE CONTROL SOCKET

|                   |   |
|-------------------|---|
| <u>SQ Flag</u>    | 7 |
| F1 → F2 (Trans)   | 6 |
| Audio Output (A1) | 5 |
| Audio Input (A2)  | 4 |
| <u>Trans Key</u>  | 3 |
| 12 V DC           | 2 |
| Frame Ground      | 1 |

SIGNALLING:

Remote Control Socket

RAH Unit

SQ Flag

Enables audio .

Trans Key

Depress PTT

F1 → F2 (Trans)

F1/F2 to F2

SQ Flag

Message lamp on

Enclosure

Sealed case

## E. REMOTE CONTROL CONSOLE

The specifications are shown in Table Q . The block diagram of the Remote Control Console (RCC) unit is shown in Figure 57 .

Depressing the PTT switches the standard DC command (DC Comd) onto the RC cable. Microphone voice messages are simultaneously applied to the cable.

Depressing the F2 switch generates a 100 Hz subaudible tone. The tone is applied to the RF cable to command the base station to the transmit frequency (F2). This allows the base to acquire the global repeater for F1 transmissions to an out of range mobile transceiver.

Depressing the PAGE switch generates sequential tones required to unsquelch pocket pagers (1).

(1) These are paging tones used to unsquelch "pocket" pager receivers designed by the Pittsburgh Research Center (PRC).

TABLE Q

REMOTE CONTROL CONSOLE (RCC)  
SPECIFICATIONS

|                        |   |
|------------------------|---|
| USE:                   | Used in the mining complex "nerve" centers to generate remote control signalling. |
| STANDARD LOAD:         |   |
| RC Cable               | 300 ohms  |
| AC POWER:              |   |
| AC                     | 117 V AC  |
| Standby Battery        | 12 V lantern battery  |
| CONNECTOR:             |   |
| Microphone             | Type  |
| RC Cable               | Type  |
| ENCLOSURE:             | Sealed enclosure  |
| SIGNALLING:            |   |
| Depressing F2 Switch   | Generates 100 Hz $\pm$ 20 Hz  |
| Depressing PAGE Switch | Generates 1000 Hz $\pm$ 100 Hz tone and DC Comd                                   |
| Depress PTT Switch     | DC Comd   |

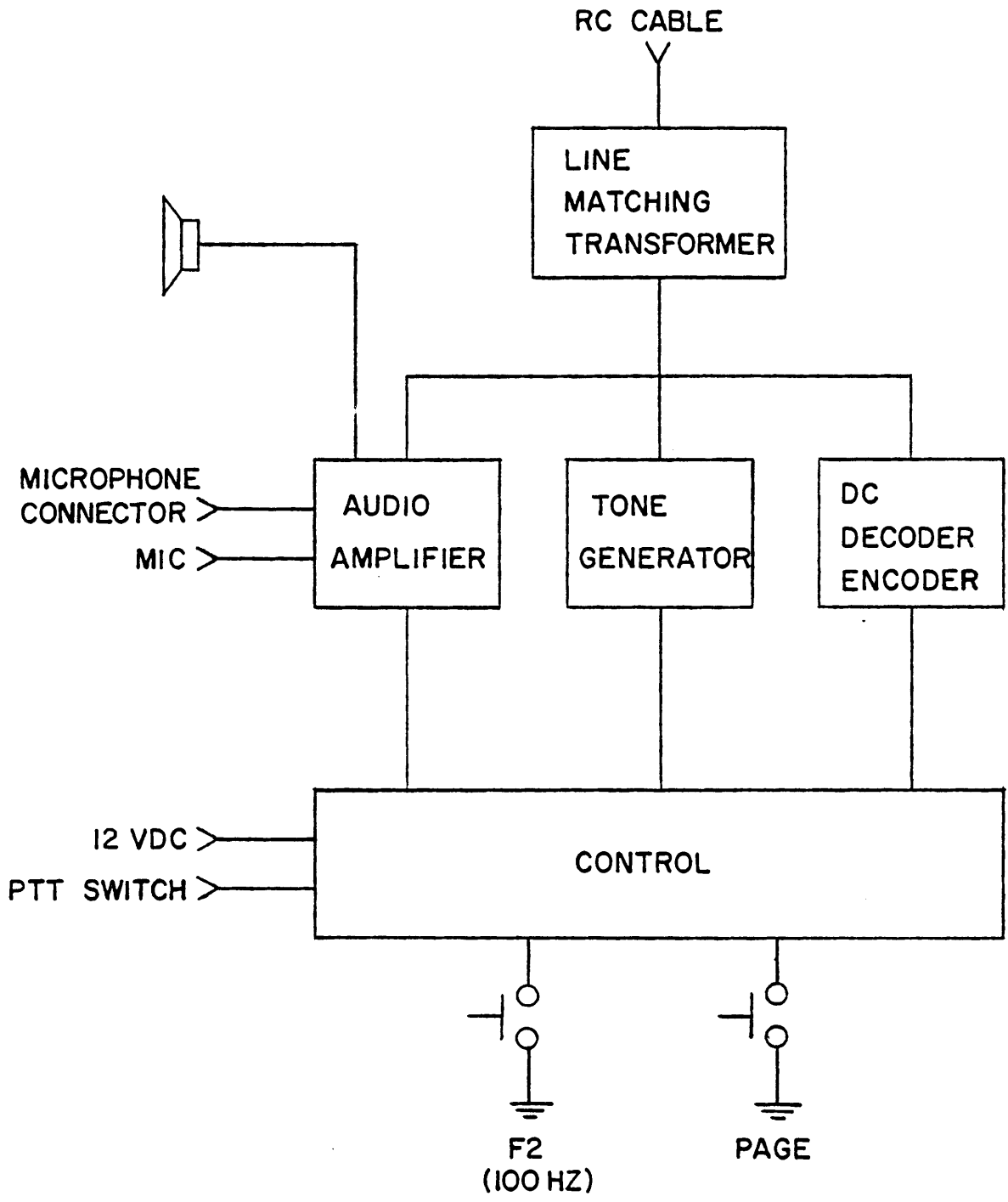

FIGURE 57 REMOTE CONTROL CONSOLE (RCC)



## F. VEST TRANSCEIVER SPECIFICATIONS

The electrical specifications for the vest transceiver are shown in Table R . They are similar to the standard transceiver specifications with many notable exceptions. First, the RF output power is limited to 4 Watts. This prevents the transceiver magnetic moment (M) from exceeding the safe limit of 2.5 ampere turn meter. The design includes tone signalling capabilities (100 and 1000 Hz). Secondly, and most importantly, the transceiver modules have been designed exclusively for use in hazardous atmosphere per Underwriters Laboratory Document UL 913 (and MSHA requirements).

The receiver, synthesizer, transmitter, antenna, and battery pack plug into a wiring harness that includes the speakers and control head. Maintenance requires troubleshooting to the module level. Module servicing is strictly prohibited other than by factory certified electrical technicians.

The block diagram is shown in Figure 58.

TABLE R  
 VEST  
 TRANSCEIVER SPECIFICATIONS

|                     |  |
|---------------------|--|
| USE:                | Transceiver for use by roving miners and rescue teams.   |
| MSHA Approved Model | ART-29 Transceiver   |
| RF OUTPUT LOAD:     | Optimized to drive tuned loop antenna.   |
| POWER REQUIREMENTS: |  |
| Operating Voltage   | 11 V DC  |
| Demand Currents     |  |
| Receiving Standby   | 20 mA (max)  |
| Receiving Audio     | 260 mA (max)   |
| Transmit            | 800 mA (max)   |
| Enclosure           | ABS plastic 2½x5½x1 inches (WLD) with canyon type DS connectors.   |
| Garment             | Nylon mesh with pockets for modules.   |
| Wire Harness (1)    | Vest wiring harness including control head epaulet speakers, tuned loop connector, speaker jack and connected for transceiver modules. |
| Antenna Module:     |  |
| Type                | Tuned loop with sealed tuning unit. Switch for F1 F2 (Trans) command.  |
| Magnetic Moment     | 2.1 amper turn meter   |

(1) Wire harness for approved vest will not accept power from standard battery pack.

Control Head Functions:

|                 |                       |
|-----------------|-----------------------|
| Volume Control  | Adjust speaker volume |
| Squelch Control | Set Threshold squelch |
| Page Switch     | Subaudible tone       |
| Signal Switch   | 100 Hz tone           |
| PTT Switch      | Key transmitter       |

Receiver Module:

|                               |  |
|-------------------------------|--|
| Enclosure Symbol              | Intrinsically safe A1 receiver<br>ART-29 P/N 301C193 |
| Frequency Range               | 60 to 1000 kHz                                       |
| Sensitivity                   | 1.0 microvolt 12 dB sinad                            |
| Selectivity                   |  |
| 3 dB BW                       | 10 kHz (minimum)                                     |
| 70 dB BW                      | 22 kHz   |
| Two Signal Selectivity        | 65 dB (minimum)                                      |
| Spurious Response<br>Rejector |  |
| Image                         | Better than 90 dB                                    |
| IF                            | Better than 60 dB                                    |
| Audio Output                  | 0.4 Watt into 8 ohms                                 |
| Squelch                       |  |
| Threshold                     | 3.0 microvolt  |
| Tight                         | 10.0 microvolt                                       |

Synthesizer Module:

|                  |  |
|------------------|--|
| Enclosure Symbol | Intrinsically safe A2 synthesizer ART-29 P/N 301C192 |
| Frequency Range  | 60 to 1000 kHz                                       |
| Tuning Increment | 5 kHz  |
| Peak Deviation   | $\pm 2.5$ kHz  |

Transmitter Module:

|                  |  |
|------------------|--|
| Enclosure Symbol | Intrinsically safe A3 transmitter ART-29 P/N 301C194 |
| Output Power     | 4 Watts (adjustable)                                 |
| Power Flatness   | $\pm 1$ dB   |

Permissible Battery Pack:

|                  |  |
|------------------|--|
| Enclosure Symbol | Intrinsically safe APP-2 Nicad battery ART-29. Must be recharged in fresh air. |
|------------------|--|

Vest Antenna Module

|                 |                                    |
|-----------------|------------------------------------|
| Magnetic Moment | 2.1 ampere turn meter <sup>2</sup> |
| Area            | 0.13 meter <sup>2</sup>            |
| Switching       | F1/F2 switching                    |

DC Characteristics

|                |                     |
|----------------|---------------------|
| Type           | Nikel-Cadium        |
| Output Voltage | 11.7 V DC           |
| Capacity       | 500 mA <sup>H</sup> |

Limiting

|                                    |                   |
|------------------------------------|-------------------|
| Maximum Instantaneous Peak Current | 4.0 amperes (max) |
| Foldback                           | 2.5 amperes       |

Fail Safe: Redundant current limiting circuits.

Fuses None

Connector Canyon DE-95

Standard Battery Pack:

Enclosure Symbol APP-1 Nicad Battery ART-29

Type Nicad battery

Output Voltage 11.7 V DC

Capacity 500 mA<sup>H</sup>

Fuse 2A

The vest can only be used inby with a MSHA approved battery pack.

The vest transceiver block diagram is illustrated in Figure 58 .

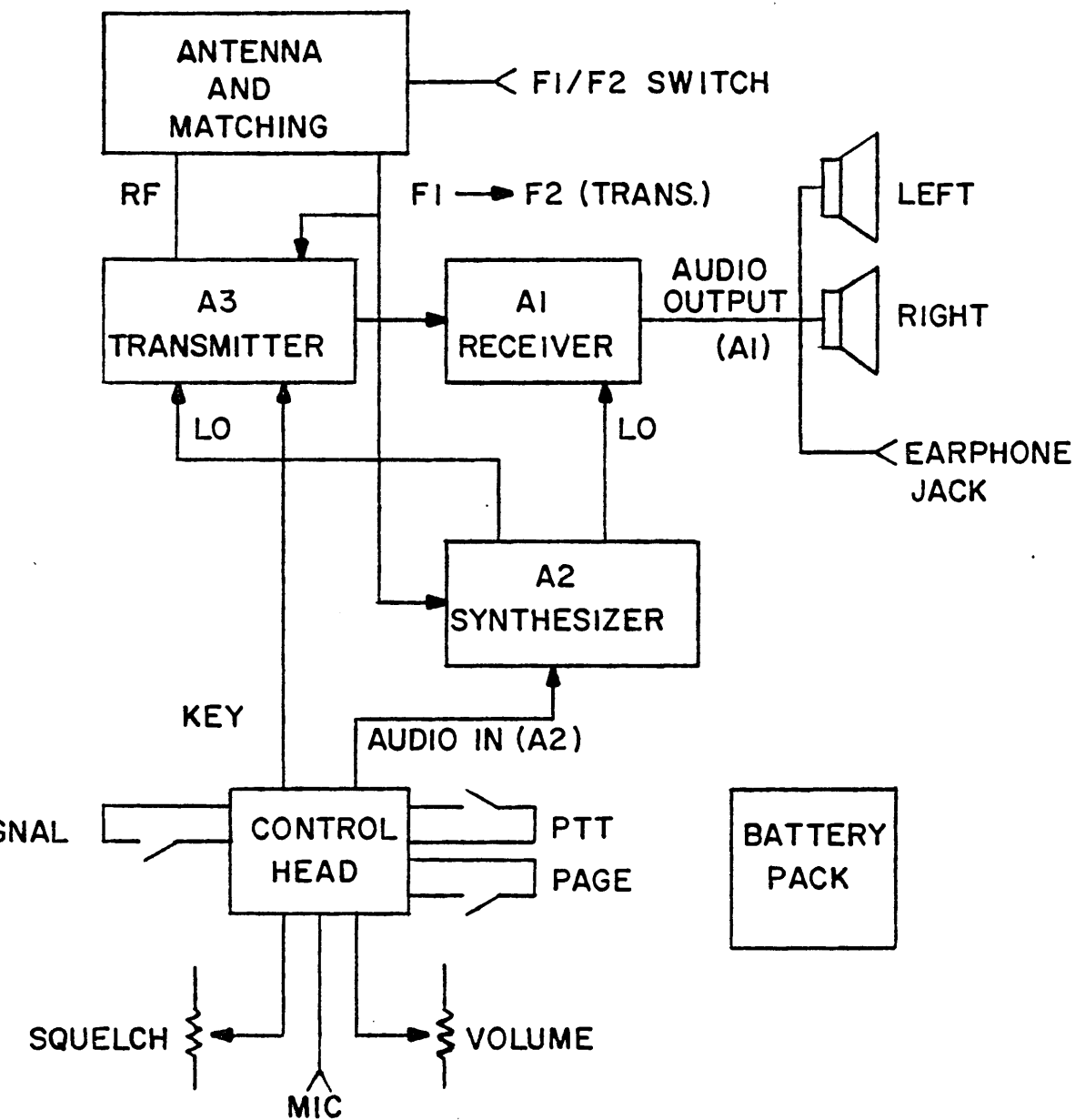

FIGURE 58 VEST TRANSCEIVER BLOCK DIAGRAM

The tuned loop antenna module includes a F1/F2 switch. Depressing the switch generates the F1 → F2 (Trans) command. This tunes the synthesizer to the frequency (F2) and keys the transmitter module (A3).

Depressing either the PTT, or SIGNAL switch on the control head keys the transmitter to the frequency (F1). The receiver is always tuned to the frequency (F1). Depressing the PAGE switch keys the transmitter to the frequency (F2). This is used in cellular repeater switching (See Figure 9).

The receiver (A1) module incorporates a noise operated squelch network. The recovered audio out (A1) signal is used to drive dual epaulet speakers and the earphone jack. The receiver (A1) module plug into the interconnecting harness.

The transmitter (A3) DC module incorporates the power and RF switching relay function.

#### 1. Permissible Battery Pack

Figure 59 illustrates the block diagram of the battery pack. The battery current limiting circuitry meets the Intrinsically Safe Electrical Circuits and Application requirements for use in hazardous locations per Underwriters Laboratory Document UL 913.

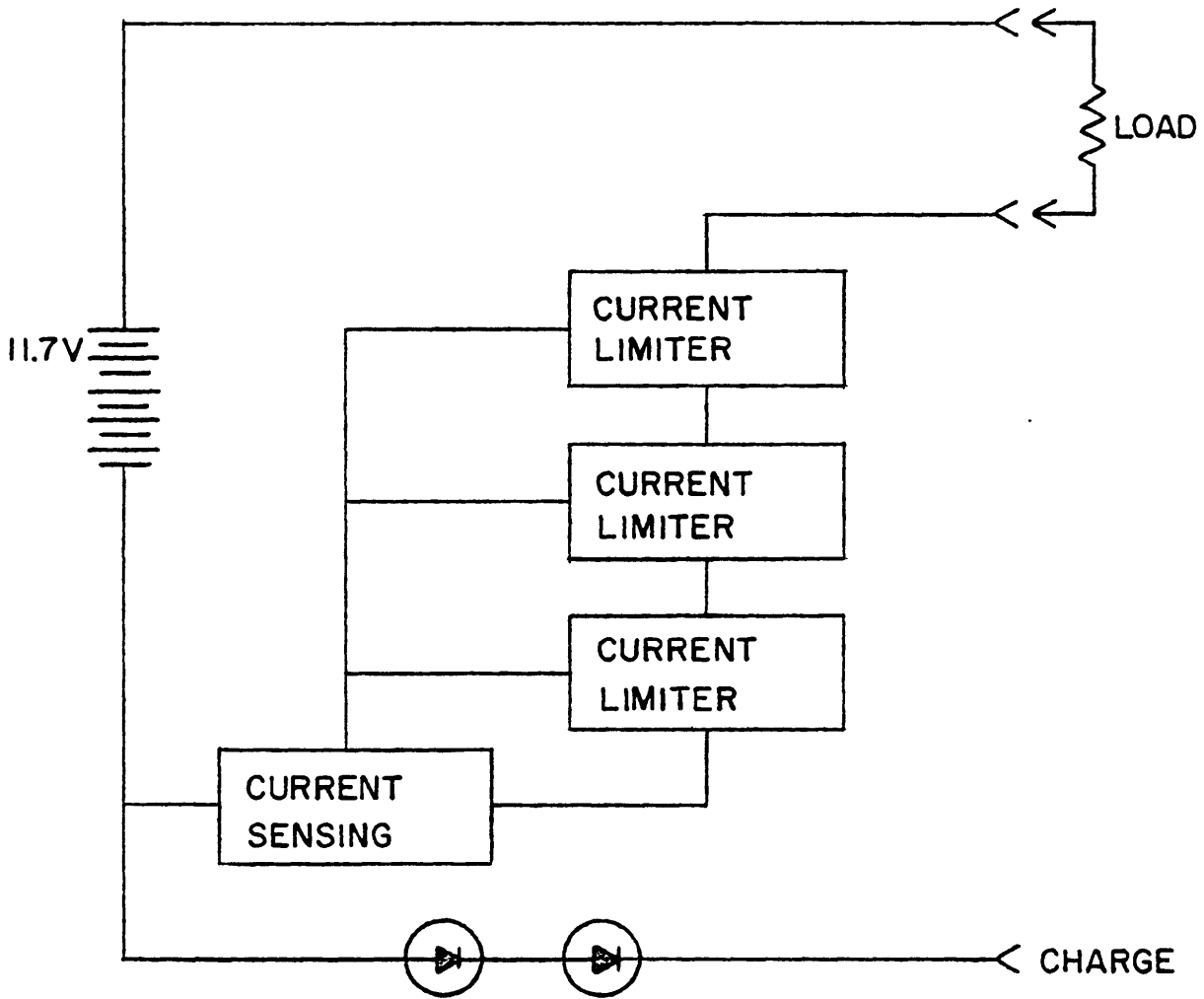

FIGURE 59 BLOCK DIAGRAM OF PERMISSIBLE BATTERY PACK



The battery pack at 11.7 V DC is limited to supplying less than 5 amperes instantaneously or continuously at any accessible terminal. The pack consists of an 11.7 V DC, 500 mah rechargeable nickel-cadmium battery with double redundant current limiting circuits. The pack is potted and sealed in an ABS plastic case.

The circuit consists of three independent current limiting circuits in series but sharing one common sensing resistor. When pack is in overload condition, fold-back condition occurs essentially disconnecting the battery from the load. The circuit is reset by simply removing the short or load then reapplying load.

## 2. ART-29 Vest Transceiver

Figure 60(a) illustrates an individual wearing the vest transceiver. The vest includes transceiver modules and speaker assemblies.

A wire harness interconnects the transceiver modules supported in pockets on the vest garment. On the top of the vest at the shoulder blade area, a pair of epaulet speakers are enclosed in pockets. The epaulet speakers are oriented to direct sound waves along the neck of the individual towards the miner's ears. The miner's hardhat acts as an acoustical collection chamber for sound waves. The vest is designed with Velcro fasteners technique to enable the wire harness

and all modules to be easily removed for the purpose of cleaning the vest. Figure 60(b) shows the tuned loop on the back of the vest.

(a) FRONT VIEW

(b) REAR VIEW

FIGURE 60. FRONT AND REAR VIEWS OF VEST TRANSCEIVER

## G. REPEATER TRANSCEIVER SPECIFICATIONS

The electrical specifications of the global and cellular repeater are identical. The specifications are also similar to the standard transceiver specifications because they use the same radio circuit modules with the exception of the AllR control board.

### 1. Repeater Block Diagram

The repeater block diagram is shown in Figure 61.

The AllR is the mother board for the A1, A2, A3 and A4 modules. The AllR control board connects the RF power amplifier (A4) output directly to the RF output connector. The RF in signal is connected directly to the receiver (A1) input circuits.

The repeater incorporates two synthesizer (A2) PC boards to enable simplex/half duplex mode of operation. That is, F2 RF in signals are received and demodulated by the receiver (A1). Simultaneously, the recovered audio output (A1) signal is applied through the AllR board to the synthesizer (A2, F1). This signal (audio input (A2)) frequency modulates the synthesizer low signal. The exciter (A3) and RF power amplifier (A4) increase the modulated signal power to 20 Watts.

To conserve standby power, the AllR includes a noise operated squelch network. This network keys the exciter and RF transmitter on only when an RF signal is applied to the receiver input terminals.

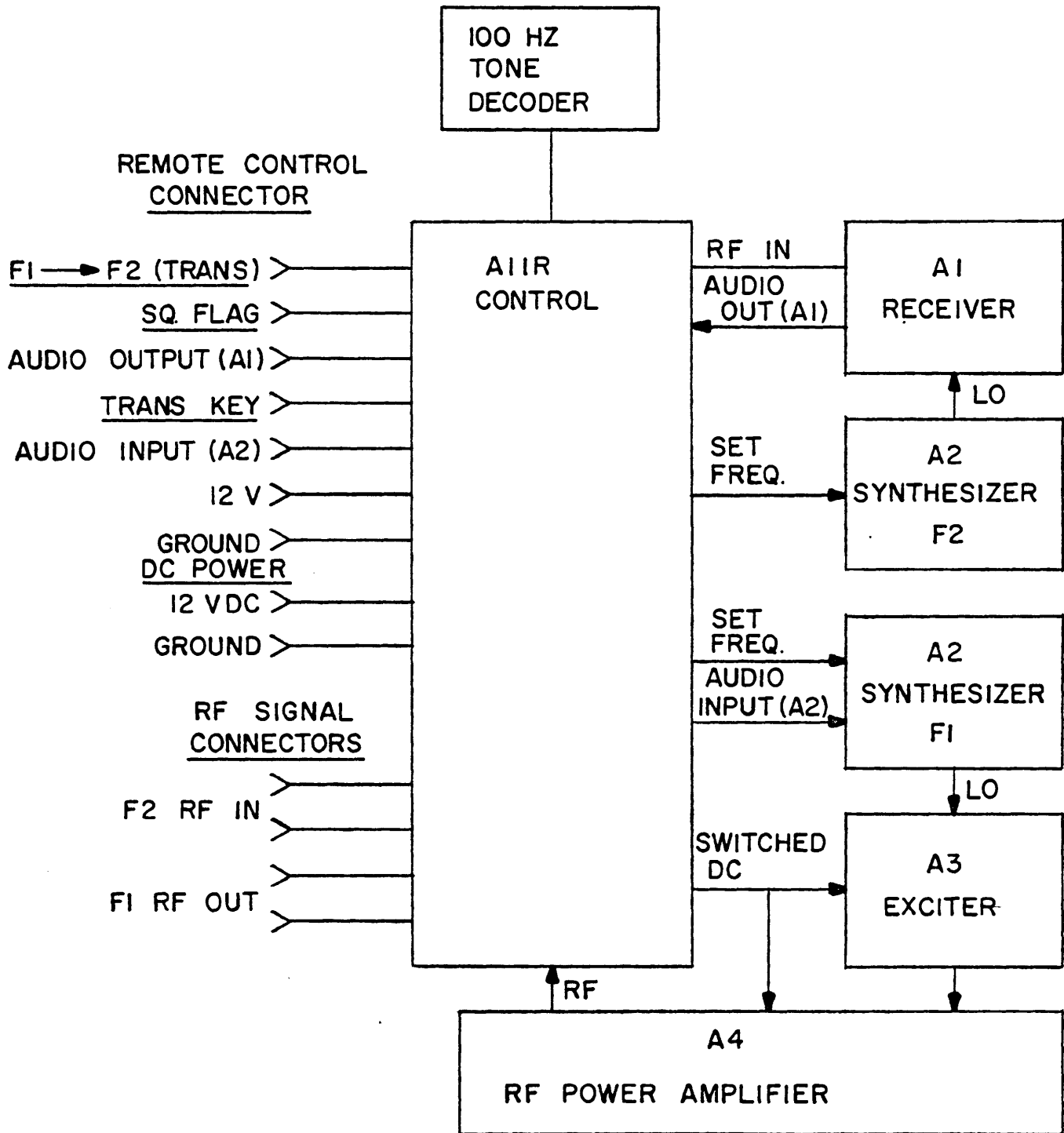

FIGURE 61 REPEATER BLOCK DIAGRAM

The AllR board also includes a 100 Hz tone decoder. Unlike the All board, it is the tone decoder that generates the SQ Flag command signal.

The RCT unit can be directly interconnected with repeater by a standard RCH cable.

The repeater receives its DC power from the standard system AC to DC converter which also includes a standby battery.

## H. STANDARD MODULE SPECIFICATIONS

The modules used in the radio system were provided as proprietary products by the Mine Safety Appliances Company (MSA). The MSA part numbers are shown in the specification.

### 1. Receiver Specification

|                             |   |
|-----------------------------|---|
| PC Board Symbol             | A1  |
| MSA Part Number             | D468179   |
| Frequency Range             | 60 to 1000 kHz  |
| Sensitivity                 | 1.0 microvolt 12 dB Sinad   |
| Spurious Response Rejection |   |
| Image                       | Better than 90 dB   |
| IF                          | Better than 60 dB   |
|                             | No other responses  |
| Audio Output                |   |
| Transceivers                | 0 dBm into 600 ohms for<br>2.5 kHz peak deviation<br>signal ( $F_m = 1$ kHz). |
| Squelch                     |   |
| Threshold                   | 1.0 microvolt   |
| Audio Output Power          | 0 dBm   |
| Hum and Noise               |   |
| Squelched                   | 45 dB below rated audio<br>output power                                       |
| Unsquelled                  | 40 dB   |

## 2. Synthesizer Specifications

|                  |  |
|------------------|--|
| PC Board Symbol  | A2   |
| MSA Part Number  | D468180  |
| Frequency Range  | 60 to 1000 kHz                                 |
| Tuning Increment | 5 kHz  |
| Peak Deviation   | + 2.5 kHz for 0 dBm audio<br>input (A2) signal |

## 3. Exciter

|                 |                            |
|-----------------|----------------------------|
| PC Board Symbol | A3                         |
| MSA Part Number | D468178                    |
| Output Power    | 200 mW (adjustable)        |
| Power Flatness  | + 1/2 dB<br>60 to 1000 kHz |

## 4. RF Power Amplifier

|                 |                        |
|-----------------|------------------------|
| PC Board Symbol | A4                     |
| MSA Part Number | D468183                |
| Output Power    | 20 Watts (adjustable)  |
| Power Flatness  | 1 dB<br>60 to 1000 kHz |
| Load VSWR       |                        |
| Operating       | 3:1                    |
| Momentary       | Open or short ckt.     |

## 5. Battery Pack Specifications

### Transceiver Standby

|         |                     |
|---------|---------------------|
| Type    | Sealed Lead Acid    |
| Voltage | 12 V DC             |
| Rating  | 5 Ampere-Hour       |
| Usage   | 8 Hours (R/T=10/90) |



## I. RF LINE COUPLER AND ANTENNA SPECIFICATIONS

The RF line coupler is used with the base station and repeater transceiver. The global repeater uses two RF line couplers to efficiently couple MF signals to the "wireplant". Figure 38 illustrates the equivalent circuit of the coupler. Figure 19 shows that the coupler may be easily clamped around electrical conductors in the "wireplant".

Tuned loop antennas are used with vehicular transceivers and cellular repeaters.

TABLE S  
RF LINE COUPLER  
SPECIFICATIONS

|   |                              |
|---|------------------------------|
| Type  | Clamp around toroidal design |
| Part Number   |                              |
| 4" inside diameter  | ACU-10-4                     |
| 1" inside diameter  | ACU-10-1                     |
| Transfer Impedance ( $Z_t$ )  |                              |
| ACU-10-1  |                              |
| 350 kHz   | 10.0 ohms                    |
| 520 kHz   | 11.2 ohms                    |
| 820 kHz   | 17.8 ohms                    |
| ACU-10-4  |                              |
| 520 kHz   | 4.0 ohms                     |
| Dielectric Withstanding<br>Voltage (cable to coupler<br>frame and inductor winding) | 50,000 V (minimin)           |

TABLE T  
ANTENNA SPECIFICATIONS

|                  |                                  |
|------------------|----------------------------------|
| TYPE:            | Twin-Loop Design                 |
| ENCLOSURE:       | Lexan                            |
| FINISH:          | Non-Reflecting Black             |
| MAGNETIC MOMENT: | 5.0 ATm <sup>2</sup> (min)       |
| PHYSICAL SIZE:   | 14 inches high<br>28 inches long |

## VI. FIELD DEMONSTRATION

The results of the field demonstrations in the four mines will be described in the following sections.

### A. MAGMA COPPER COMPANY, SAN MANUEL DIVISION

The underground mine is located near San Manuel, Arizona. Block caving mining method is used on three operating levels. Figure 62 is an illustration of grizzly and production level drifts.

FIGURE 62. GRIZZLY AND PRODUCTION LEVEL DRIFTS

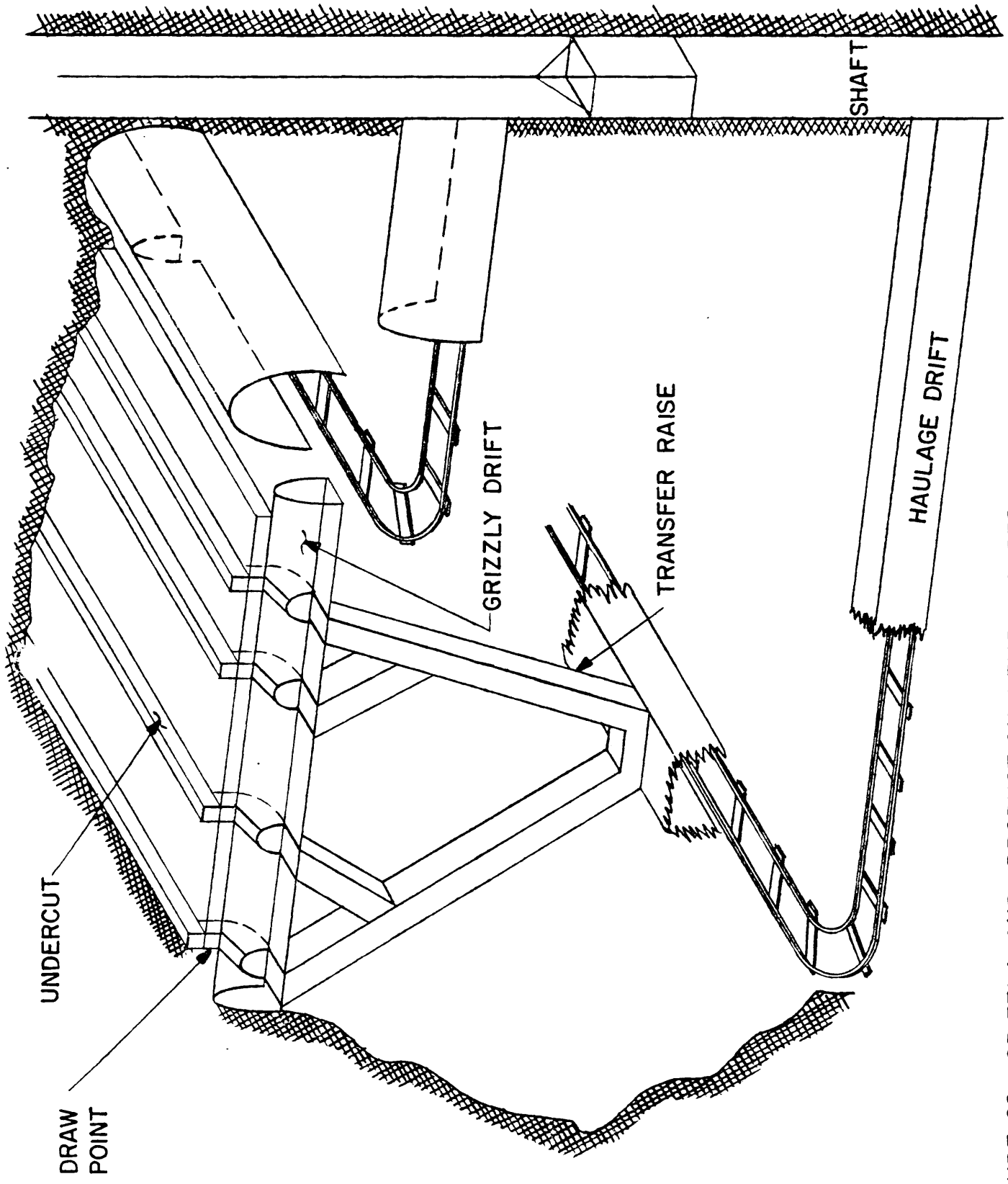
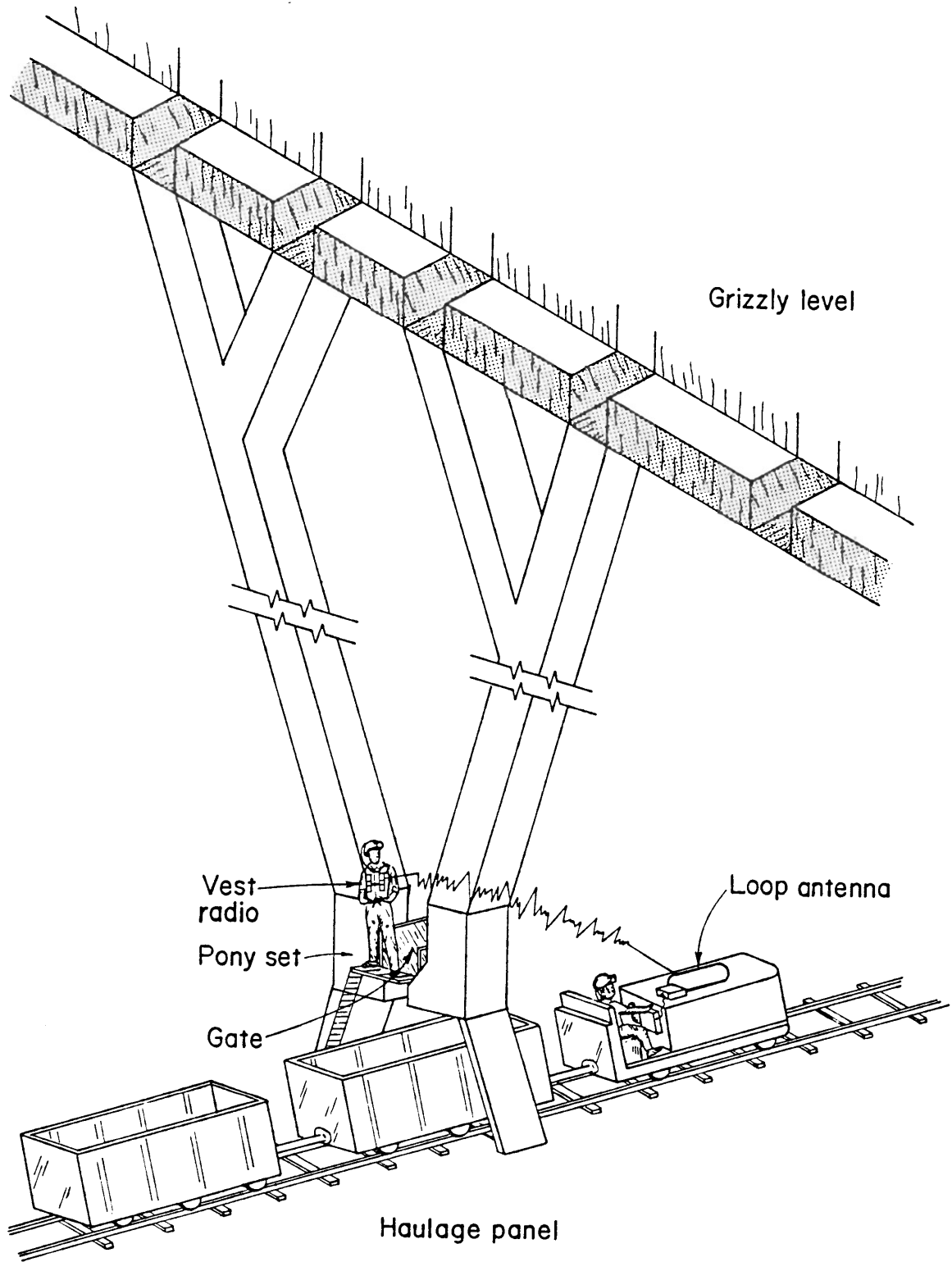

FIGURE 62 GRIZZLY AND PRODUCTION LEVEL DRIFTS

The upper grizzly level is used for gathering muck and loading the Y-transfer raises. The transfer raises are temporary muck storage bins and loading chutes for the trains. Trains on the lower production level transport muck to dump and hoist area of the mine. Hoists are used to lift the muck from the dump surge bins to the surface of the mine. Train loading process is illustrated in Figure 63.

FIGURE 63. ILLUSTRATION OF LOADER AND MOTORMAN LOADING TRAIN



In actual practice, the loaderman in the pony set blinks incandescent lamps to signal the motorman to move the train during the loading process.

Vest radios were evaluated for use in the loading process. The use of radio reduced the time required to load the train. It should be noted that vest radios are expected to be of great value in unloading clogged transfer raises.

1. Magma's Communication System

The underground mine uses trolley radios and an audio system to communicate in the mine. The physical locations of these communications resources are illustrated in Figure 64.

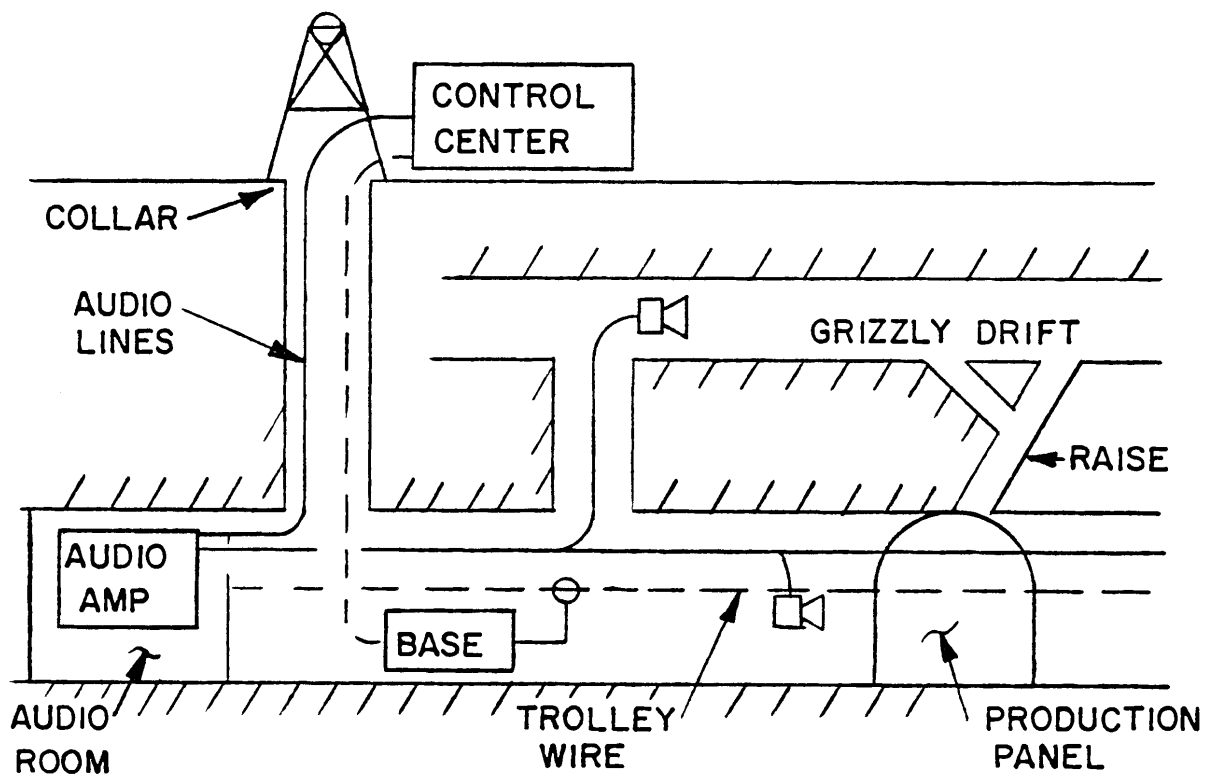

FIGURE 64. MAGMA COMMUNICATIONS RESOURCES



The audio system is similar to a pager telephone system. Remote audio heads (speaker symbol) are located at strategic locations in the drifts. Each head includes a microphone, speaker, and push-to-talk switch. A four (4) conductor cable connects each head to a central audio amplifier (audio room) and the surface control center. The surface control center is the nerve center in the Magma communication system. Roving supervisors on the 2315 grizzly and 2375 production levels use the audio system to coordinate muck haulage with the dispatcher. The mucking supervisor on the grizzly level identified which transfer raises are being filled. The trolley communication system (dashed lines) is used by the dispatchers to direct the locomotive motormen to a production panel with "full" transfer raises. The dispatcher controls rail traffic to and from the train car dump and hoist areas. Fifteen (15) 300 VDC trains are used in the rail haulage system. Battery powered service locomotives are also used on the rail system to transport men and materials in the mining process. Although these locomotives have carrier current transceivers, the transceivers can only be used when the locomotive is stopped. The trolley communication system uses a dedicated wire to distribute trolley signals in the main haulage drifts. "J Boxes" are used to couple the 145 kHz signal to the trolley wire. The base station drives the dedicated wire and is remotely controlled from the control center. Each shaft cage has a hoist communication system that enables the surface hoist operator to communicate with the cage man.

---

## 2. The MF Communication System

MF radio equipment is used to create a party line production/maintenance network. The equipment is also used to improve shaft communications.

In the mine, MF signals propagate (tunnel mode) on the existing mine wiring; specifically, the audio and dedicated carrier wires. Figures 65 and 66 are mine maps of the 2315 and 2375 levels respectively. The maps indicate the locations of these conductors in the grizzly and production level drifts.

MF signals are coupled to the audio conductors by an RF line coupler in the audio room. The audio room MF base station is remotely controlled from the surface control center. The audio conductors and base station provide radio coverage on both the grizzly and production levels.

A MF base station and RF line coupler are also used to couple MF signals to the dedicated wire.

Field demonstration of the equipment showed that the mucking and production supervisors were able to immediately communicate first hand information about the haulage status. Maintenance supervisors were immediately advised of haulage equipment problems. The radio system decreased the time required to reach keymen from an average of 35 minutes to seconds.

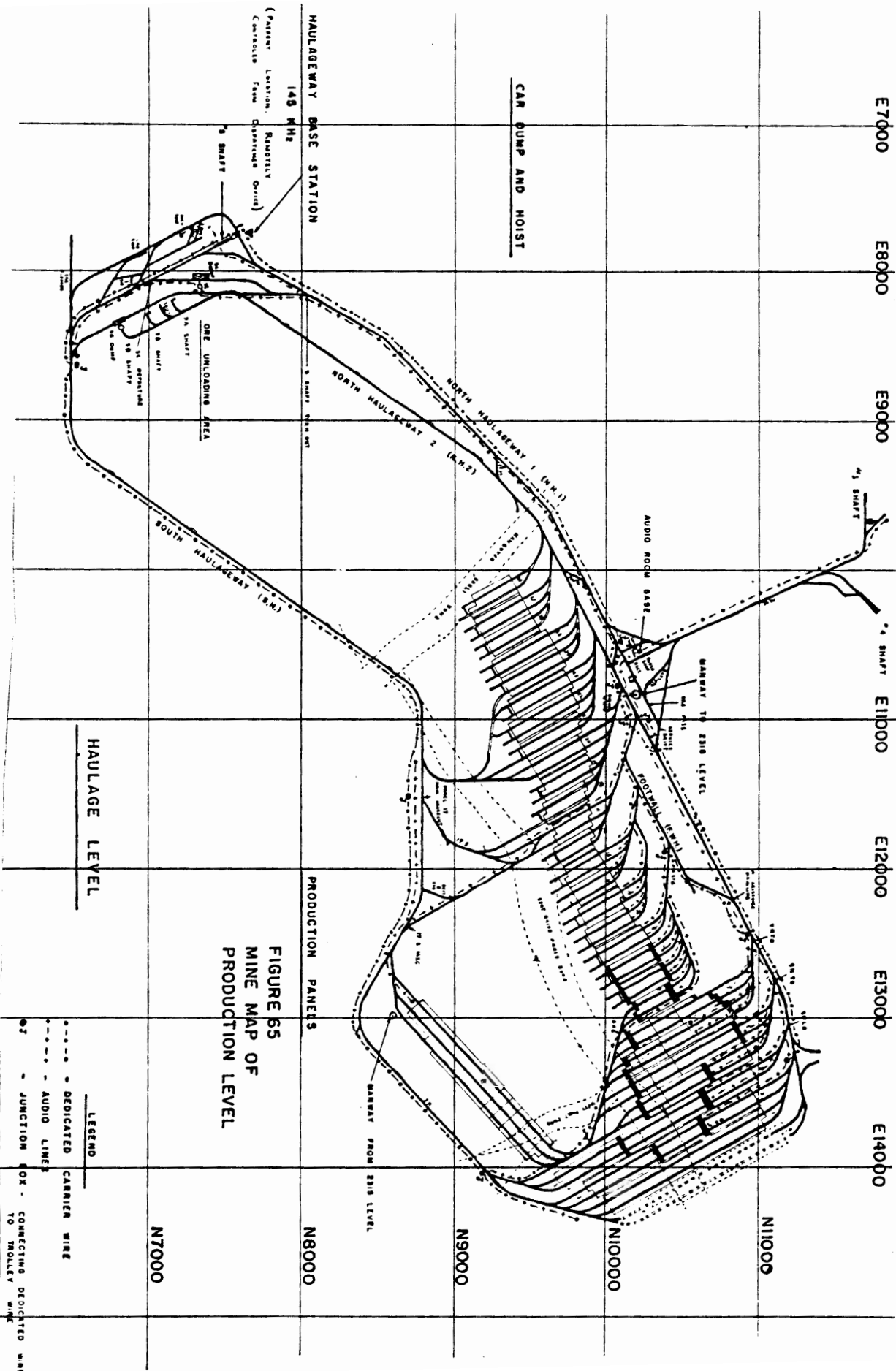

FIGURE 65  
MINE MAP OF  
PRODUCTION LEVEL

LEGEND

- DEDICATED CARRIER WIRE
- - - - - AUDIO LINE
- OX - JUNCTION BOX - CONNECTING DEDICATED WIRE TO TROLLEY WIRE

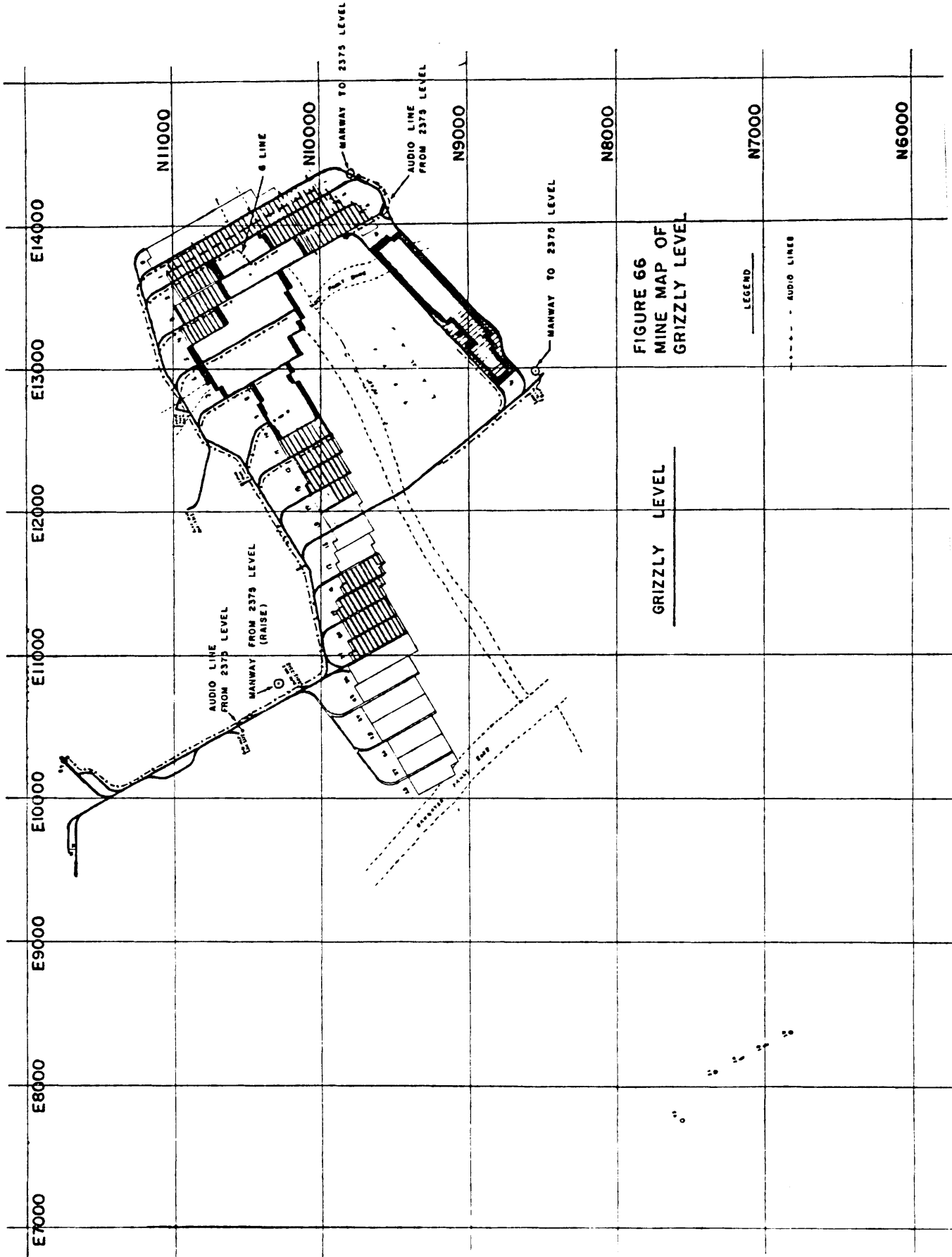

FIGURE 66  
MINE MAP OF  
GRIZZLY LEVEL

GRIZZLY LEVEL

LEGEND

--- AUDIO LINES

MF equipment on battery powered service vehicles enabled the dispatcher to communicate with moving equipment on the rail system.

An MF hoist communications system was also evaluated in the field test.

The present hoist communications system exhibits serious maintenance problems. The "bat" antennas used to illuminate the wire rope at the head frame sheave wheel is difficult and costly to maintain. An MF loop antenna was used to illuminate the wire rope at the collar. A RF line coupler was used to efficiently couple signals to the cage transceiver..

### 3. Test Results

A number of tests were performed at Magma to measure the signal to noise ratio of the transmitted radio signals at the base station location. All tests were performed at 400 kHz.

#### a. Test 1 - Vest Communications To Audio Room Base Station From Grizzly and Production Levels

A base station was installed in the 2375 audio room. A 1" RF line coupler clamped around the East or West audio "wire-plant" bundles emerging from the audio amplifier bank. A Singer MN-25T signal strength meter was connected to a 4" RF line coupler clamped around the same wire bundle for measurement purposes. Signal levels were measured from a roving miner wearing an ART-29 vest transceiver. A trolley rectifier is also located in the audio room. This resulted in noise

level variations and poor signal to noise tests at times.

The audio quality tests are purely subjective and pegged to a listening scale of 0 to 10 as follows:

0 = no squelch break

1 = squelch barely broken - not audible

3 = speech approx. 80% audible with heavy noise

5 = speech audible with medium noise

8 = speech clear and audible with low noise

10 = speech clear no noise

The tested locations are keyed to the mine maps for the 2375 and 2315 levels.

TABLE U  
 VEST TRANSCEIVER COMMUNICATIONS  
 TO AUDIO ROOM BASE STATION  
 (VIA 2315 and 2375 LEVEL AUDIO CABLES)

| TEST NO. | VEST LOCATION        | NOISE LEVEL dB | SIGNAL LEVEL dB | S/N dB | AUDIO QUALITY | NOTES   |
|----------|----------------------|----------------|-----------------|--------|---------------|---|
| 1        | 2375 20 Crossover    | 36             | 60              | 24     | 10            | Couplers on West audio cables routed on 2375 & past rectifier |
| 2        | N Haulage 2          | 36             | 59              | 23     | 9             |   |
| 3        | 20 North             | 36             | 55              | 19     | 8             |   |
| 4        | Manway               | 36             | 67              | 31     | 8             |   |
| 5        | Raise                | 36             | 50              | 14     | 8             |   |
| 6        | Raise 50"            | 36             | 48              | 12     | 7             |   |
| 7        | Top Manway 2315      | 21             | 50              | 29     | 9             | Couplers on East audio line - 2315 away from rectifier        |
| 8        | NFD T.O.             | 21             | 55              | 34     | 9             |   |
| 9        | Panel 20             | 21             | 50              | 29     | 8             |   |
| 10       | Panel 18             | 21             | 47              | 26     | 8             |   |
| 11       | Panel 16 T.O.        | 20             | 41              | 21     | 6             |   |
| 12       | Panel 14 North       | 20             | 35              | 25     | 5             |   |
| 13       | Panel 12 N Lunchroom | 18             | 50              | 32     | 9             |   |
| 14       | Panel 18 N           | 18             | 43              | 25     | 6             |   |
| 15       | Panel 4 N            | 18             | 38              | 20     | 5             |   |
| 16       | Panel 4 N 150 "      | 18             | 30              | 12     | 4             |   |
| 17       | Panel 2 N T.O.       | 18             | 32              | 14     | 4             |   |
| 18       | 2 Panel 6 Line       | 18             | 27              | 9      | 3             |   |

| <u>TEST NO.</u> | <u>VEST LOCATION</u>         | <u>NOISE LEVEL dB</u> | <u>SIGNAL LEVEL dB</u> | <u>S/N dB</u> | <u>AUDIO QUALITY</u> | <u>NOTES</u>              |
|-----------------|------------------------------|-----------------------|------------------------|---------------|----------------------|---------------------------|
| 19              | P41 South A<br>2315 Manway   | 35                    | 36                     | 1             | 1                    |                           |
| 20              | P41 South A<br>2375          | 35                    | 36                     | 1             | 1                    | Couplers on<br>West audio |
| 21              | P41 S to<br>Main Line        | 36                    | 37                     | 1             | 3                    | line on 2375              |
| 22              | P17 S to<br>Main Line        | 35                    | 36                     | 1             | 3                    |                           |
| 23              | P17 B South                  | 33                    | 52                     | 19            | 8                    |                           |
| 24              | P17 North B                  | 33                    | 56                     | 23            | 9                    |                           |
| 25              | 16 Footwall                  | 33                    | 34                     | 1             | 1'                   |                           |
| 26              | 15 N Turnout                 | 35                    | 49                     | 14            | 8                    |                           |
| 27              | P10 Stub<br>Turnout          | 35                    | 44                     | 11            | 6                    |                           |
| 28              | P10 Stub<br>Lunchroom        | 35                    | 37                     | 2             | 3                    | Couplers on<br>West audio |
| 29              | 10 Crossover<br>Main Line    | 34                    | 43                     | 9             | 5                    | line 2375                 |
| 30              | NH2 Main<br>Line             | 34                    | 39                     | 5             | 4                    |                           |
| 31              | P12 350'<br>Service<br>Drift | 34                    | 36                     | 2             | 3                    |                           |
| 32              | Ore Pass<br>Turnout          | 34                    | 46                     | 12            | 6                    |                           |
| 33              | Ore Pass                     | 34                    | 56                     | 22            | 8                    |                           |



Summary:

Generally, communications near audio lines in the grizzly were good while some signals became weak away from the lines. Communication was acceptable to good at 30 of the 33 locations tested. This test clearly demonstrates the potential performance and usefulness of the vest radio.

Magma personnel were very pleased with this radio coverage.

b. Test 2 - Vehicular and Vest Communications To Audio Room Base Station Via Audio Conductors On Production Level

The base station (with coupler) and the signal strength meter (with 4" coupler) were installed in the audio room as in Test 1 using the West cable bundle for the 2375 level. A vehicular radio and antenna were mounted on a battery locomotive for signal strength tests around the entire 2375 loop. A second person wearing a vest also rode the locomotive during the test. Due to the heavy production, traffic tests had to be made quickly while on the move and could not be repeated.

TABLE V  
 VEHICULAR AND VEST COMMUNICATIONS TO  
 AUDIO ROOM BASE STATION (VIA MAIN HAULAGEWAY  
 AUDIO CONDUCTORS)

| TEST NO. | LOCATION               | NOISE LEVEL dB | VEHICULAR       |     |               | VEST      |          |               | NOTES              |
|----------|------------------------|----------------|-----------------|-----|---------------|-----------|----------|---------------|--------------------|
|          |                        |                | SIGNAL LEVEL dB | S/N | AUDIO QUALITY | SIG LEVEL | VEST S/N | AUDIO QUALITY |                    |
| 1        | 17 B South             | 41             | 53              | 12  | 6             | -         | -        | -             | -                  |
| 2        | 17 B North             | 40             | 58              | 18  | 8             | -         | -        | -             | -                  |
| 3        | 20 Crossover           | 40             | 60              | 20  | 8             | -         | -        | -             | -                  |
| 4        | 30 Crossover<br>NHL    | 40             | 62              | 22  | 10            | 47        | 7        | 6             |                    |
| 5        | 5 Shaft<br>Turnout     | 40             | 61              | 21  | 10            | 50        | 10       | 7             |                    |
| 6        | 3C Shaft               | 40             | -               | -   | -             | -         | -        | -             | Dead no audio line |
| 7        | 3D Departure           | 39             | 40              | 1   | 5             | 39        | 0        | 1             | " " " " " "        |
| 8        | 17 South<br>Main Cross | 39             | 50              | 11  | 8             | 43        | 4        | 5             |                    |
| 9        | 2A South               | 39             | 52              | 12  | 6             | 40        | 1        | 1             | Noisy area         |
| 10       | 2A Mid Panel           | 39             | 54              | 15  | 5             | 41        | 2        | 2             | Noisy fan          |
| 11       | 3A North               | 39             | 50              | 11  | 6             | 39        | 0        | 1             | No audio line      |

TABLE V CON'D

| TEST NO. | LOCATION              | NOISE LEVEL dB | SIGNAL LEVEL dB | S/N dB | AUDIO QUALITY | SIG LEVEL | VEST S/N | AUDIO QUALITY | NOTES          |
|----------|-----------------------|----------------|-----------------|--------|---------------|-----------|----------|---------------|----------------|
|          |                       |                |                 |        |               |           |          |               |                |
| 12       | 3N Ladder Drift       | 39             | 61              | 22     | 10            | 51        | 12       | 8             |                |
| 13       | 5N Turnout            | 39             | 57              | 18     | 9             | 42        | 4        | 3             |                |
| 14       | 7N Turnout            | 39             | 55              | 16     | 8             | 43        | 4        | 3             |                |
| 15       | 10X Service Stn       | 39             | 52              | 13     | 7             | 46        | 7        | 3             |                |
| 16       | 10X Off Motor         | 39             | -               | -      | -             | 48        | 9        | 4             | Vest off motor |
| 17       | Service Drift Turnout | 39             | 54              | 15     | 8             | 54        | 15       | 8             |                |

Summary:

Vehicular communications to the audio room were good except from areas not having audio lines. Good results were obtained from the middle of loading panel 2A which has no audio lines. Vest communications were poor whenever the operator transmitted from inside the locomotive. However, the vest could receive all signals.

c. Test 3 - Vehicular Communication To Base Station  
Relocated To 5 Shaft (Via Dedicated Wire on 2375 Level)

The base station and signal strength test set were moved to 5 shaft and coupled to the dedicated carrier line using a 1" coupler for the base and a 4" coupler for the signal strength test set. The locomotive had the same vehicular transceiver with antenna. No rectifier was near the 5 shaft area. Measurements were made as in Test 2 from around the 2375 loop. Again, a vest was used on the locomotive.

TABLE W  
 VEST AND VEHICULAR COMMUNICATIONS TO 5 SHAFT BASE STATION

| TEST NO. | LOCATION                  | NOISE LEVEL dB | 1680 VEHICULAR |        |         |           | VEST   |         |                 | NOTES |
|----------|---------------------------|----------------|----------------|--------|---------|-----------|--------|---------|-----------------|-------|
|          |                           |                | SIG LEVEL      | S/N dB | Audio Q | SIG LEVEL | S/N dB | AUDIO Q |                 |       |
| 1        | 3C departure              | 30             | 80             | 50     | 10      | 75        | 45     | 10      |                 |       |
| 2        | 3D departure              | 30             | 76             | 46     | 10      | 65        | 35     | 7       |                 |       |
| 3        | Between 3D dep & 17 South | 30             | 73             | 43     | 8       | 61        | 31     | 5       |                 |       |
| 4        | 17 S Crossover            | 30             | 70             | 40     | 8       | 60        | 30     | 3       |                 |       |
| 5        | 41B North                 | 30             | 35             | 5      | 2       | -         | -      | 0       | No carrier line |       |
| 6        | 8A South                  | 28             | 37             | 9      | 3       | -         | -      | 0       | " " "           |       |
| 7        | Footwall P11              | 28             | 50             | 22     | 7       | -         | -      | 0       | " " "           |       |
| 8        | 10X NH2                   | 28             | 50             | 22     | 7       | -         | -      | 0       | " " "           |       |
| 9        | 5 North                   | 28             | 52             | 24     | 8       | 35        | 7      | 3       |                 |       |
| 10       | 2 North                   | 28             | 62             | 34     | 9       | 38        | 10     | 3       |                 |       |
| 11       | 20 North                  | 28             | 58             | 30     | 7       | 52        | 24     | 5       |                 |       |
| 12       | 30 Crossover              | 28             | 52             | 24     | 8       | 43        | 15     | 4       |                 |       |
| 13       | 5 Shaft Turnout           | 28             | 53             | 25     | 8       | 59        | 31     | 6       |                 |       |

Summary:

As in Test 2, signal levels and communications were good except in areas lacking a carrier line. The vehicular radio audio quality was acceptable in 12 of 13 test points. The vest radio audio quality was acceptable anywhere in the area of the carrier line and did perform better from the locomotive than during the audio line tests.

d. Test 4 - Hoist Communications Test Base Station In Hoist Control Center

A vehicular antenna was mounted in the hoist control room at shaft 3C with the antenna about 3 feet from the wire rope and about 8 feet from the wire rope drum.

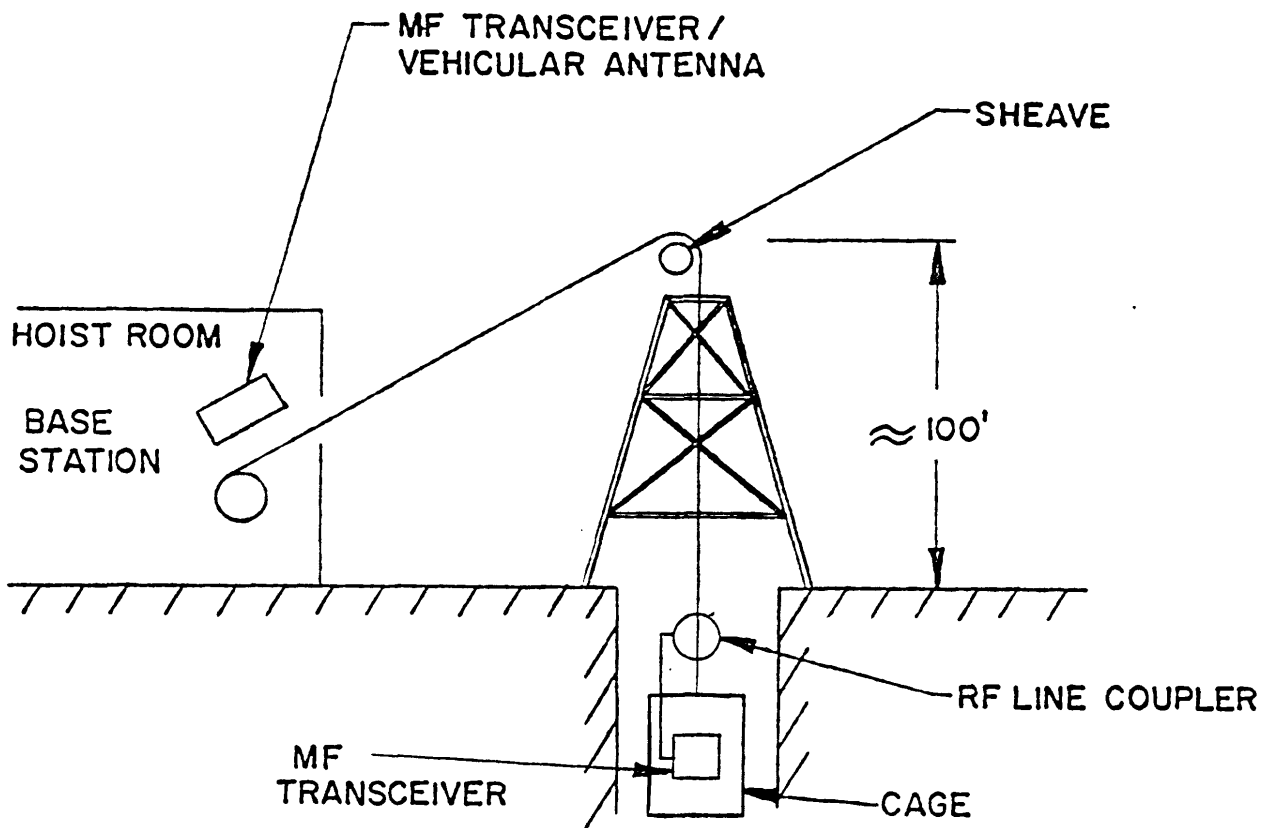

FIGURE 67. ILLUSTRATION OF HOIST COMMUNICATIONS SYSTEM

This antenna was coupled to the signal strength test set. A base station for communications was located in the same area with a vehicular antenna mounted just ahead of the large antenna 3 feet from the rope. Another transceiver (battery powered) was mounted in the cage using a 4" coupler on the rope just above the bonnet.

Test results are as follows:

TABLE X  
HOIST COMMUNICATIONS SIGNAL LEVEL  
CAGE TO BASE AT THE DRUM

| TEST NO. | CAGE LOCATION               | NOISE LEVEL dB | SIG LEVEL | S/N dB | AUDIO QUALITY | COMMENTS |
|----------|-----------------------------|----------------|-----------|--------|---------------|----------|
| 1        | Collar                      | -5             | 35        | 40     | 10            |          |
| 2        | 400' below collar           | 0              | 22        | 22     | 8             |          |
| 3        | 1000' going down full speed | +3             | 45        | 42     | 10            |          |
| 4        | 1500' going down full speed | +3             | 28        | 25     | 8             |          |
| 5        | 2075' stopped               | -3             | 25        | 28     | 8             |          |
| 6        | 2675' going down            | +3             | 29        | 26     | 8             |          |
| 7        | 2750' pocket                | -3             | 25        | 28     | 8             |          |
| 8        | 2000' going up              | +3             | 27        | 24     | 8             |          |

Summary:

Good to excellent signals were obtained with no dead spots. A slight noise level was noted when the hoist was running.

e. Test 5 - Hoist Communication Test Base Station At  
The Collar

A vehicular antenna was mounted on the headframe at the collar about 3 feet from the cage rope. This antenna was used with the Singer FSM to measure noise ratio. A vehicular antenna was mounted on the headframe opposite the large antenna. A vehicular transceiver was connected to the antenna. The cage radio and coupler remained as in Test 4.



TABLE Y  
HOIST COMMUNICATION SIGNAL LEVELS  
CAGE TO BASE AT THE COLLAR

| TEST NO | CAGE LOCATION     | NOISE LEVEL dB | SIGNAL LEVEL | S/N dB | AUDIO QUALITY | NOTES        |
|---------|-------------------|----------------|--------------|--------|---------------|--------------|
| 1       | Collar            | -27            | +85          | 112    | 10            | Clear & Loud |
| 2       | 400' moving down  | -27            | +82          | 109    | 10            | " "          |
| 3       | 1000' moving down | -27            | +80          | 107    | 10            | " "          |
| 4       | 2015              | -27            | +81          | 108    | 10            | " "          |
| 5       | 2675 moving down  | -27            | +86          | 113    | 10            | " "          |
| 6       | 2675              | -27            | +85          | 112    | 10            | " "          |

Summary:

The signal strengths on this test were outstanding at all levels, with the cage moving or stopped.

Comparing the signal levels of the antenna at the hoist house and at the collar, the losses over the "sheave" wheel appear to generally range from 50 to 60 dB.

Using MF equipment in hoist communication decrease maintenance cost. Servicemen need not climb the head frame to service the "sheave" wheel antenna.

4. Conclusion

The tests at Magma clearly show that the equipment performs very well in a large multiple level mine. The Magma people were pleased with the performance and coverage.

## B. PLATEAU MINING COMPANY

The Plateau coal mine is located near Price, Utah. Annual production exceeds 1 MTPY. The mine presently operates a Gai-Tronics pager system as its primary communications network. Telephone cable (single pair) interconnects each pager telephone. Pagers are located at key points in the office, warehouse, shop, along beltways, and in the face areas.

A simplified drawing of Plateau Mine is shown in Figure 68. The Mud-water mining is in retreat status while the South faces are in an advancing status.

The existing "wireplant" includes the telephone pair cable and AC power cable. Telephone cable runs in the beltway. The beltway is more than one entry away from the Mud-water manway and the West/Main entries.

Separate 7,100 and 13,200 volt three phase AC power cables supply power to the Mud-water and South faces, respectively. Transformers along the cable supply power to the conveyor belt drives in the belt entries.

Switches are also installed in the AC cable. The AC power cable is installed in some, but not all of the manway entries.

The 7,100 and 13,200 volt cables are in the same entry at the intersection of the Mud-water and West entries.

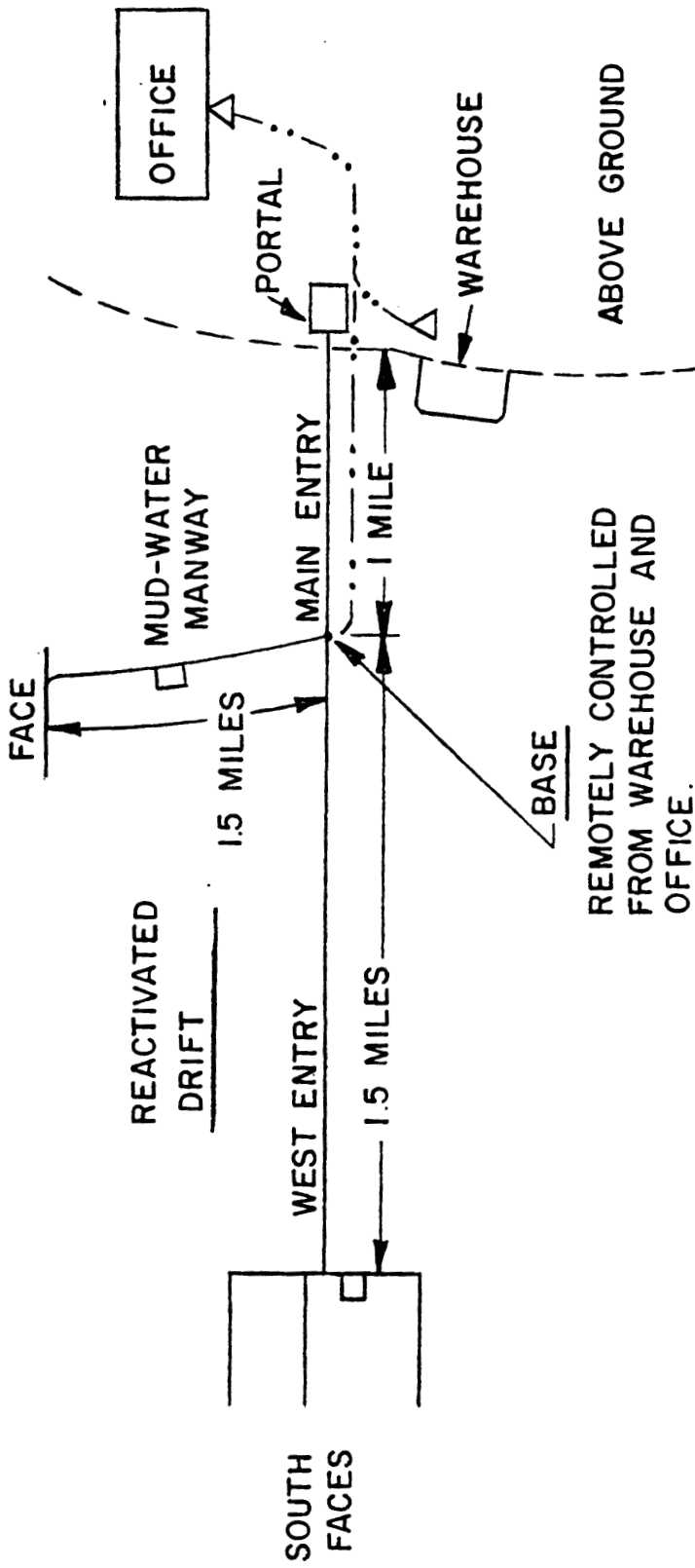

△ REMOTE CONTROL CONSOLE (RCC)

□ REPEATER

— · · — SINGLE-PAIR (RC CABLE)

FIGURE 68 SIMPLIFIED DRAWING OF PLATEAU MINE

## 1. Installation of MF Equipment

A base station and RF line couplers were located at the intersection of the Mud-water and West entries. The couplers were installed on each of the power cables. The couplers were connected to the base station through a bifilar wound signal transformer. The pager telephone cable was placed in one of the couplers.

The base station was remotely controlled from the warehouse and office remote control consoles (RCC). The assigned operating frequency was 400 kHz.

Four vehicular transceivers were installed on diesel powered tractors. The mounting of the vehicular transceiver and antenna on a diesel powered vehicle is shown in the photograph below.

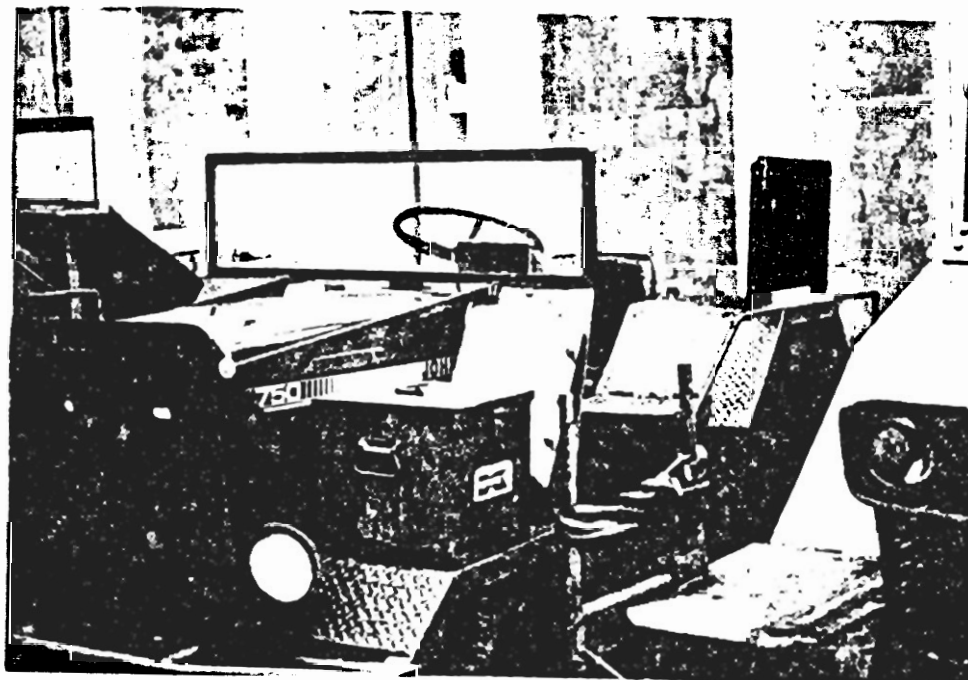

FIGURE 69. PHOTOGRAPH OF VEHICULAR TRANSCEIVER INSTALLATION

The vehicular transceiver is mounted on the front fender .

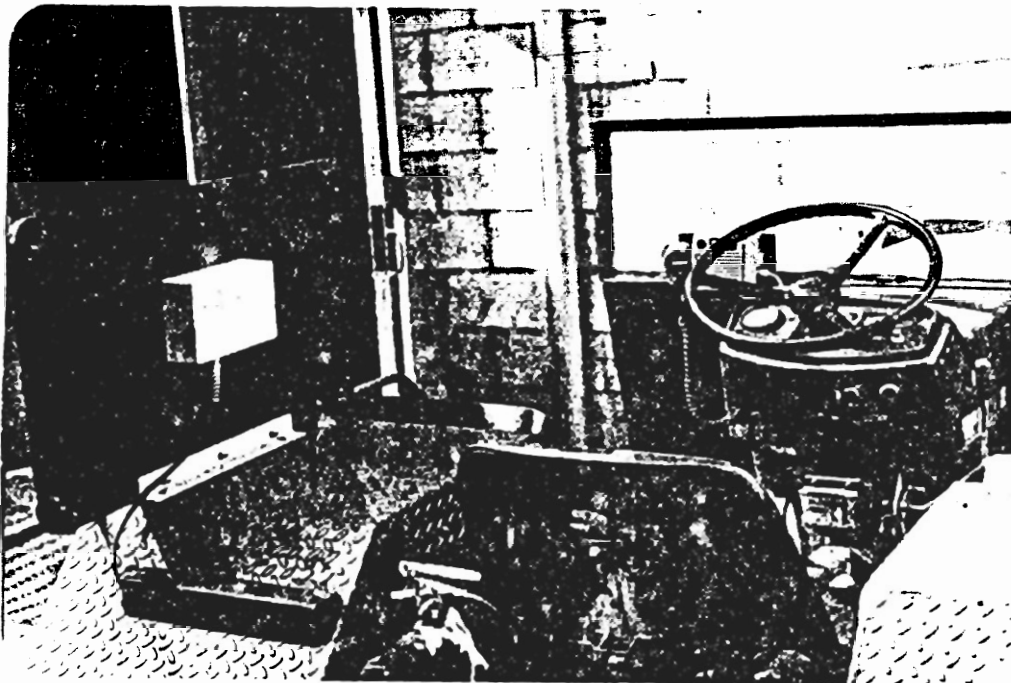

FIGURE 70. PHOTOGRAPH OF VEHICULAR ANTENNA INSTALLATION

The photographs show that the available mounting surface is limited. In the installation process, precautions were taken to protect all cabling. For example, the antenna cable is protected by welding an angle iron to the fender. The angle iron protects the antenna cable from damage.

In the initial system tests, vehicular transceivers could not talk back when in the Mud-water and South face areas. Listening was also a problem in the South area manways.

The poor communications was due to excessive transmission loss associated with the AC power transformers installed along the AC power cable. Transformers were found to introduce from 8 to 10 dB of signal loss in the AC power cable signal path.

In an attempt to improve communications quality, repeaters were installed in the Mud-water and South face areas.

## 2. Installation of Repeaters

The primary frequency (F1) remained at 400 kHz and secondary frequency (F2) was added at 520 kHz. This required that all antennas be capable of two frequency operation. The use of two frequencies allows access to global repeaters when transmitting on the frequency (F2). The global repeater boosts the received signal and retransmits it on F1.

The first F1/F2 repeater was installed in Mud-water entry, approximately 3600 feet from the base station. An additional 5000 feet down the entry is the face.

The second repeater was installed near the entrance to the South area, approximately 7000 feet from the base station. From this location to the furthest South face is approximately 6500 feet.

### 3. Test Results

Signal and noise measurements were taken at the base station location on the AC power cables serving the Mud-water and main South mining areas. Due to the constant output and fixed location of the repeaters, only one measurement was needed. These are given in Table Z.

TABLE Z

SIGNAL TO NOISE RATIO MEASUREMENTS  
AT BASE STATION FROM REPEATER LOCATIONS

Mud-Water

Noise - 12 dB

Signal - 92 dB

S/N Ratio - 80 dB

South

Noise - 2 dB

Signal - 78 dB

S/N Ratio - 80 dB



#### 4. Quality And Performance

System performance was found to be optimal when the vehicular antenna was positioned within 6 to 8 feet of the power cable and the vehicle was not running.

Under the above conditions, excellent communication quality was obtained throughout the Mud-water entry between vehicular transceiver and base station. The observation point was the remote control console (RCC) located in the warehouse. Similar results were obtained in a reactivated drift which is an entry off the Mud-water entry. Farthest attempted communication path distance in the Mud-water repeater network reached approximately 14,000 feet.

Due to limitations of time and an unexpected power failure while testing the South area, extensive results were not obtained.

#### 5. Lessons Learned

AC power cable does provide radio coverage in the mine. However, because of AC line switches, signal distribution can be interrupted when needed the most.

It is recommended that a feasibility study be made to find ways to reduce loss across transformers and open switches.

Twin-lead cable should have been installed in the manways of this mine instead of using the AC power cables for MF signal distribution. There are many advantages seen in the use of twin-lead cable. First, radio coverage can be provided all along the manways. Secondly, repeaters would not have been required lowering both equipment acquisition and maintenance cost. Finally, the complexity of the F1/F2 signalling could have been avoided.

#### 6. Demonstration Results

As soon as the MF system was installed in the mine, a continuous mining machine was buried by a rock fall at the Mud-water face. Radio was used to instantly alert the underground superintendent of the problem. The superintendent praised the use of radio for the instant alert and saving many hours in the recovery effort.

Beltmen were given vest transceivers to use along the conveyor belt line. They report that the vest was very comfortable to wear. The vest saved a great deal of time because beltmen are no longer required to walk to the nearest pager telephone.

C. YORK CANYON COAL MINE

The Kaiser Steel Corporation York Canyon Coal Mines are located in Colfax County near Raton, New Mexico. Both underground and surface mining are in progress.

The immediate area surrounding the mine is composed of flood plains, valley slopes and broad-ridge crests. Coal is produced from the York Canyon seam in a local zone of the Raton formation. The formation includes beds of sandstone, siltstone, mudstone and coal. Annual production from the underground mines exceeds 1MTPY. Kaiser uses continuous mining equipment to mine ahead of two (2) longwalls. A simplified sketch of the York Canyon mining complex is shown in Figure 71.

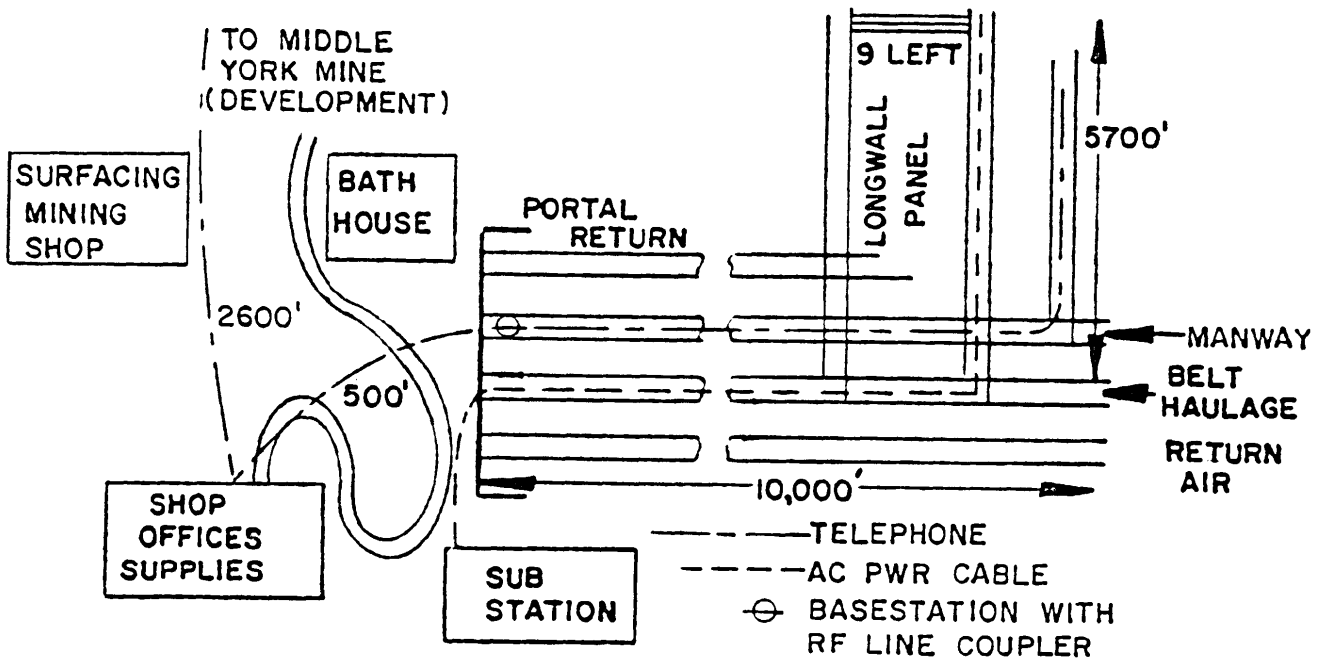

FIGURE 71. SIMPLIFIED PLAN VIEW DRAWING OF THE YORK CANYON MINE.

The four (4) entry underground mining complex was developed on a South heading for a distance exceeding 10,000 feet. The coal seam height varies along the entry; however, the average height is seven (7) feet. The entry passageways are separated by fifty (50) feet. The fresh air manway is used to transport men, supplies and equipment required in the mining process. A cross section of the manway is shown in Figure 72.

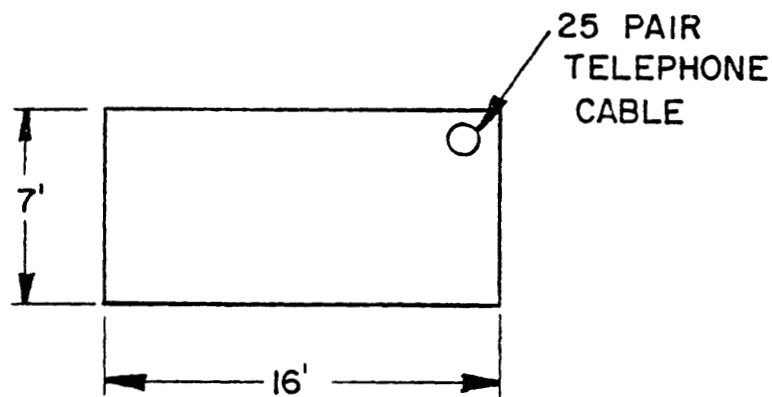

FIGURE 72. CROSS SECTION OF MANWAY (LOOKING INBY)

A shielded 25 pair telephone cable is installed on the upper right hand corner. The belt haulageway is in an adjacent entry. The passageway contains a Continental conveyor belt

haulage system, AC power cable and other electrical conductors used in the belt fire detection system. The return air passageways were originally used as part of the mine ventilation system. Bore holes to the surface are now used to transfer the return air to the surface.

Longwall panels are developed to the left of the entry. The panels are approximately 550 feet wide and 6000 feet long.

The surface substation converts the 69 kV transmission line power to 7.2 kV power for distribution in the mine.

A Gai-tronics telephone system serves the office/shop building (location of PBX), the underground mine, and the surface mining shop. The general routing of telephone cable is illustrated by the dash-dot line symbols in Figure 73.

Battery powered scooter, diesel powered "Tera Jet" jeeps, and Elkhorn man carriers are used for vehicular transportation in the mine.

#### 1. Installation of MF Equipment

Medium frequency (MF) vehicular transceivers and antennas were permanently installed on battery powered scooters and diesel powered jeeps.

The installation of the RF line coupler is shown in Figure 73.

FIGURE 73. INSTALLATION OF RF LINE COUPLER

The RF line coupler is clamped around the 25 pair telephone cable at the portal. The belt fire detection cable also threads the center of the coupler. The fire detection cable has been installed in the manway for a distance of approximately 3000 feet. Through a crosscut the cable enters the beltway and then is routed along the conveyor belt.

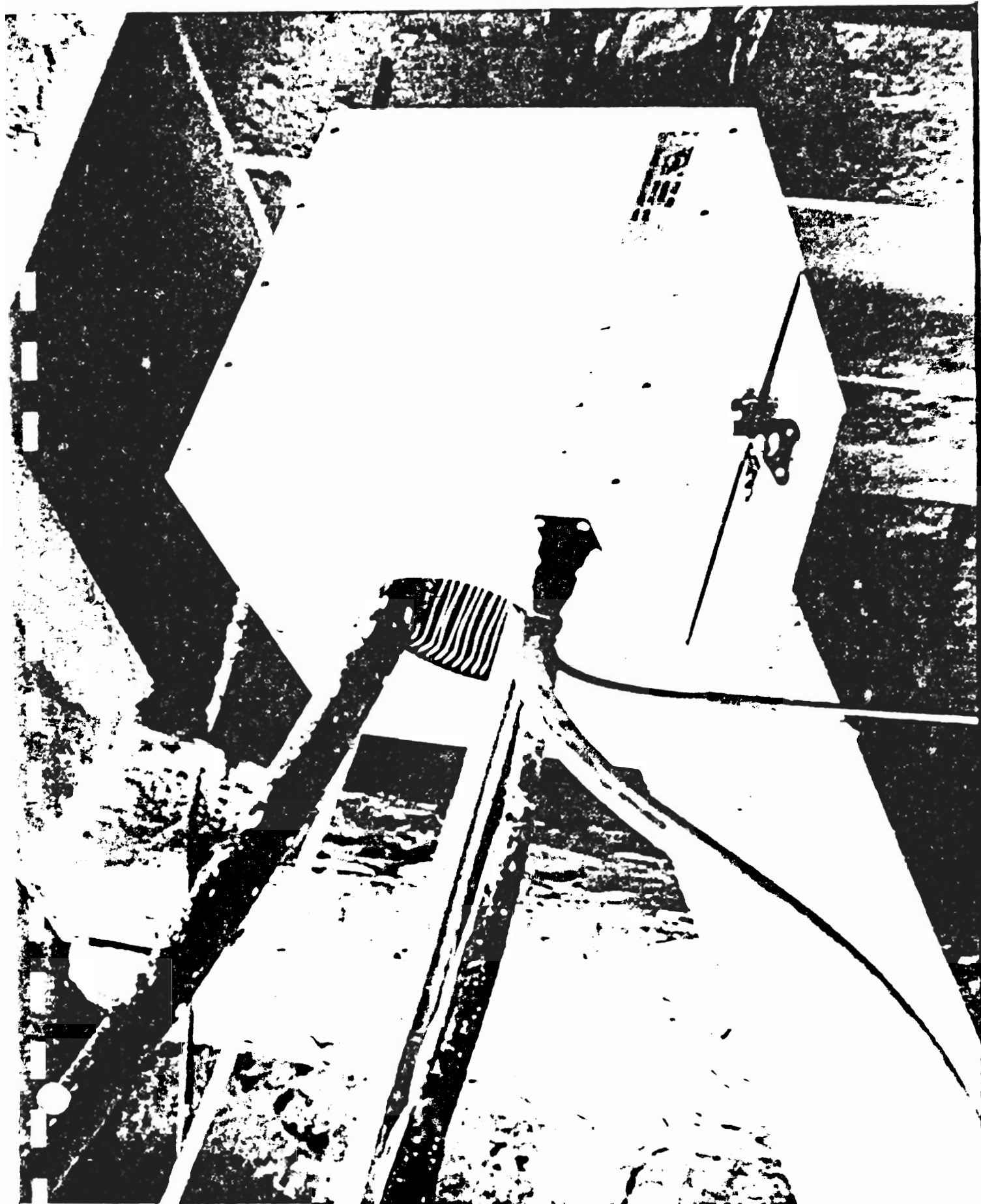

The telephone cable terminates in several junction boxes along the manway. From these boxes, telephone pairs enter crosscuts and continue to pager telephones at critical locations. The cable is finally terminated in a junction box, 6100 feet from the base station. A single pair continues along the manway for an additional 3000 feet. The cable then enters the Nine Left longwall manway.

The vehicular transceiver mounting on the "Tera Jet" jeep is shown in Figure 74.

FIGURE 74. PHOTOGRAPH OF THE TERA JET JEEP ANTENNA INSTALLATION



The vehicular transceiver remote control head (RCH) is mounted near the steering wheel. The antenna is mounted in a vertical plane to the right of the diesel engine compartment.

## 2. Measurement Results

Communications signal levels were measured at the base station with the test set-up shown in Figure 26.

The quality of the communications signals were excellent along the manways with the telephone cable.

The measured induced line current at 520 kHz was previously shown in Figure 27. Figure 75 shows the measured line current at 350 kHz. The average attenuation rate is approximately 1 dB/1000 feet as compared to 2.4 dB/1000 feet at 520 kHz.

The dashed line represents the induced line current required so that at least 70 percent of the spoken words are intelligible. The difference (in dB) between the induced line current signal (upper solid line) and the dashed (C/N = 20 dB) line at any distance represents the margin in the communications system. The margin exceeds 35 dB at one mile from the base station. The intersection of the signal and dashed lines (not shown) predicts that the maximum communication range will exceed 34,000 feet at 350 kHz. This compares favorably to the 18,000 feet expectation at 520 kHz.

FIGURE 75

INDUCED LINE CURRENT VERSUS  
VEHICULAR TRANSCIEIVER  
DISTANCE FROM BASE STATION  
 $f_0 = 350 \text{ KHZ}$   $|M| = 5.2 \text{ ATM}^2$

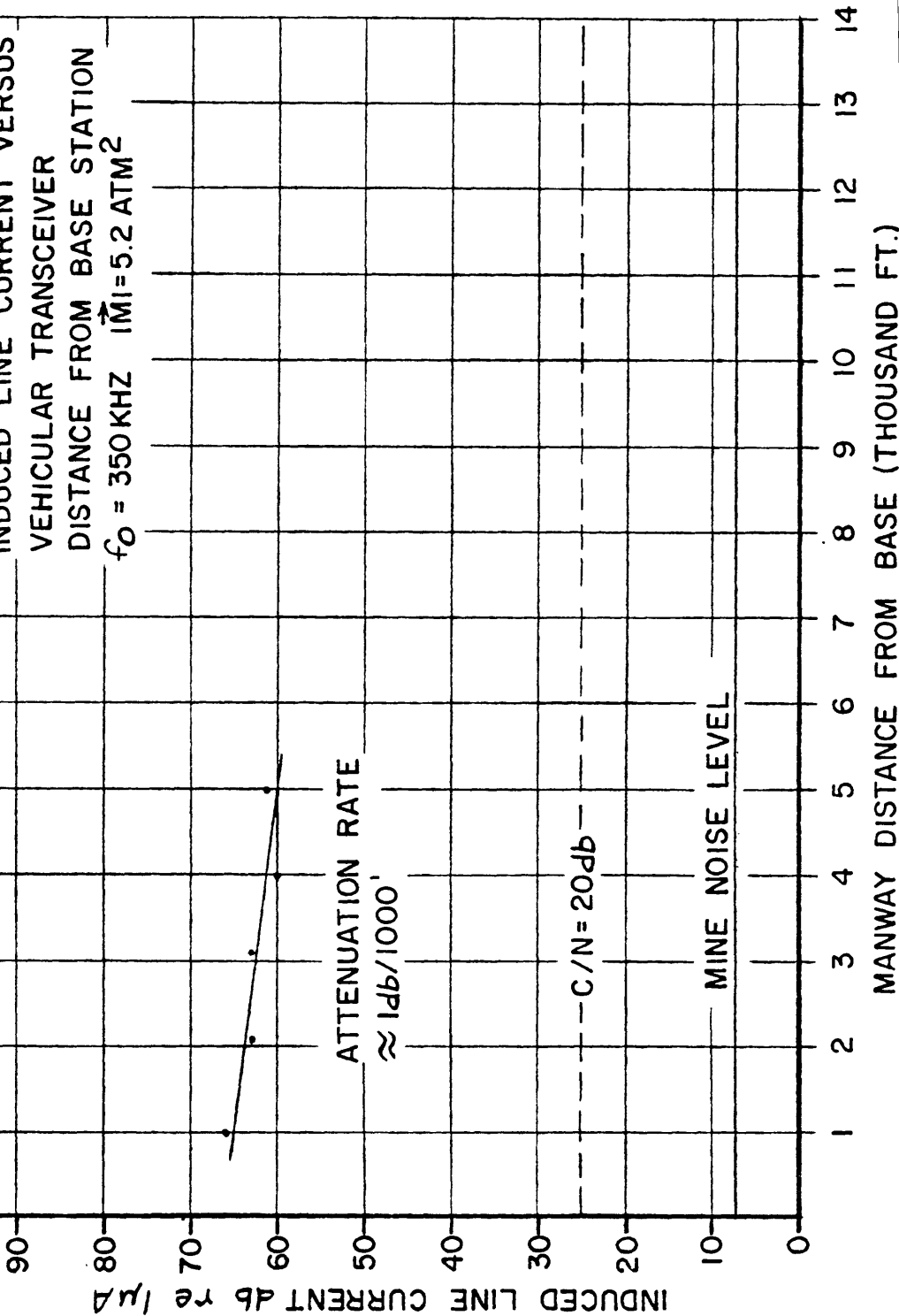

Equation (14) shows that the efficiency of coupling signals from loop antennas to cable increases with frequency. If the transmitting loop antennas are generating equal magnetic moments, the 520 kHz induced current curve must be above the 35 kHz curve at short range. The 350 kHz curve must eventually cross the 520 kHz curve owing to the higher attenuation rate of the 520 kHz signals along the telephone cable. Comparison of the 350 kHz and 520 kHz induced line current data indicates that the crossing occurs at approximately 3000 feet.

Tests were made to determine the differences in induced line current caused by the orientation of the vehicular antenna in the manway. The measured data in Figures 27 and 75 applies when the vehicular antenna is in a vertical plane (HMD) and that the plane is parallel to the telephone cable. When the antenna is in a horizontal plane (VMD), the induced current level is reduced by 2 dB. Mounting the vehicular antenna in a horizontal (as will be required in low coal) will not significantly degrade system performance.

Some interesting coupling effects were noted when the antenna was in a plane orthogonal to the cable. In coal, when the antenna (HMD) was located more than 40 feet from the cable maximum induced current was measured at the base. When the antenna (HMD) was rotated to plane parallel to the cable, induced current was minimum. This is just the opposite effect observed in the manways with cable.

It is interesting to note that vest signal level arriving at the base station location was approximately 8 dB less than vehicular signal levels. This corresponds closely with the differences in vest and vehicular antenna magnetic moments, 2.0 and 5.2 ATM<sup>2</sup>, respectively.

The vest transceiver radio coverage areas in the mine are shown in the following sketches of crosscut intersections along the manway.

FIGURE 76. RADIO COVERAGE AREA AT CROSS CUT 31 ALONG MANWAY

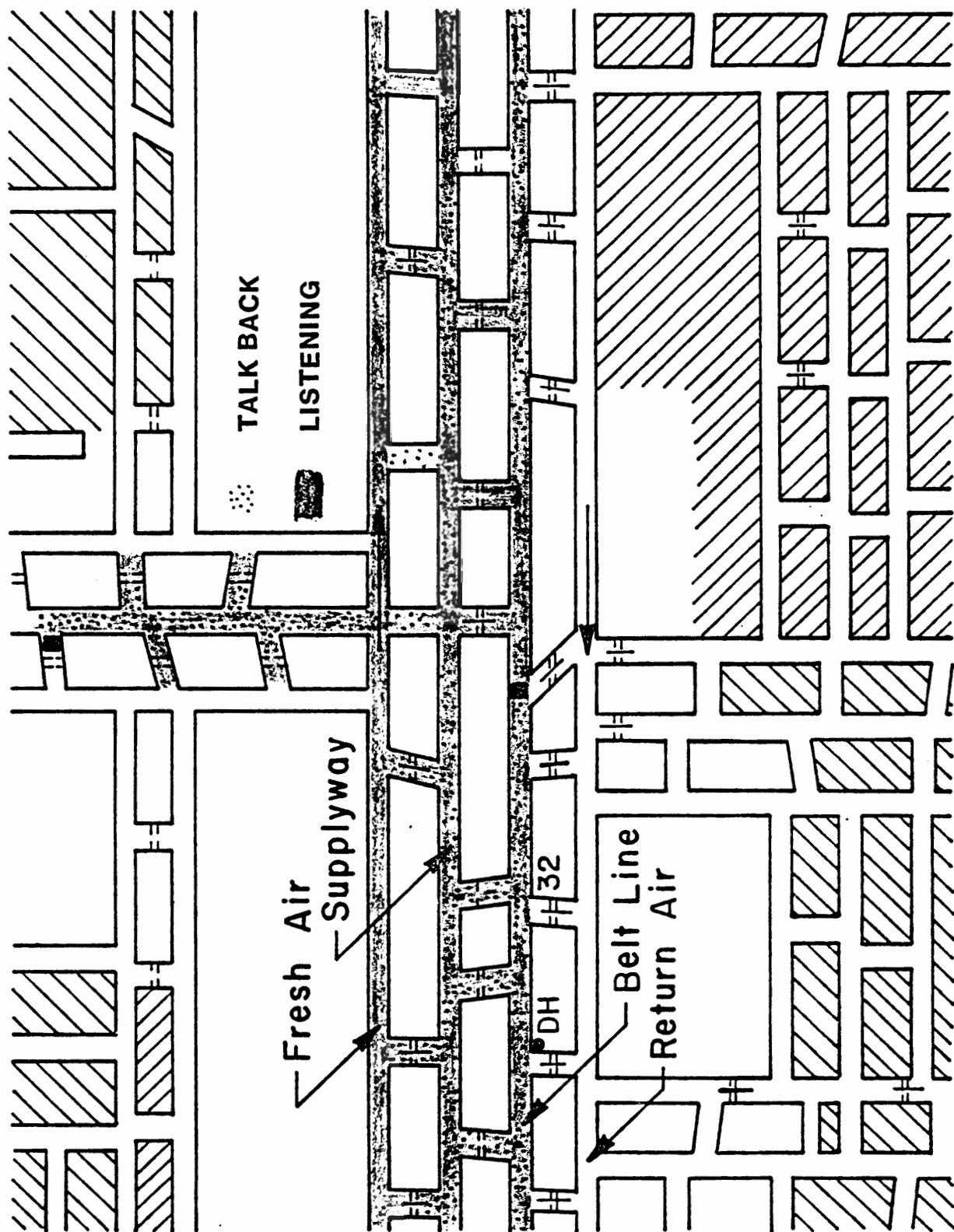
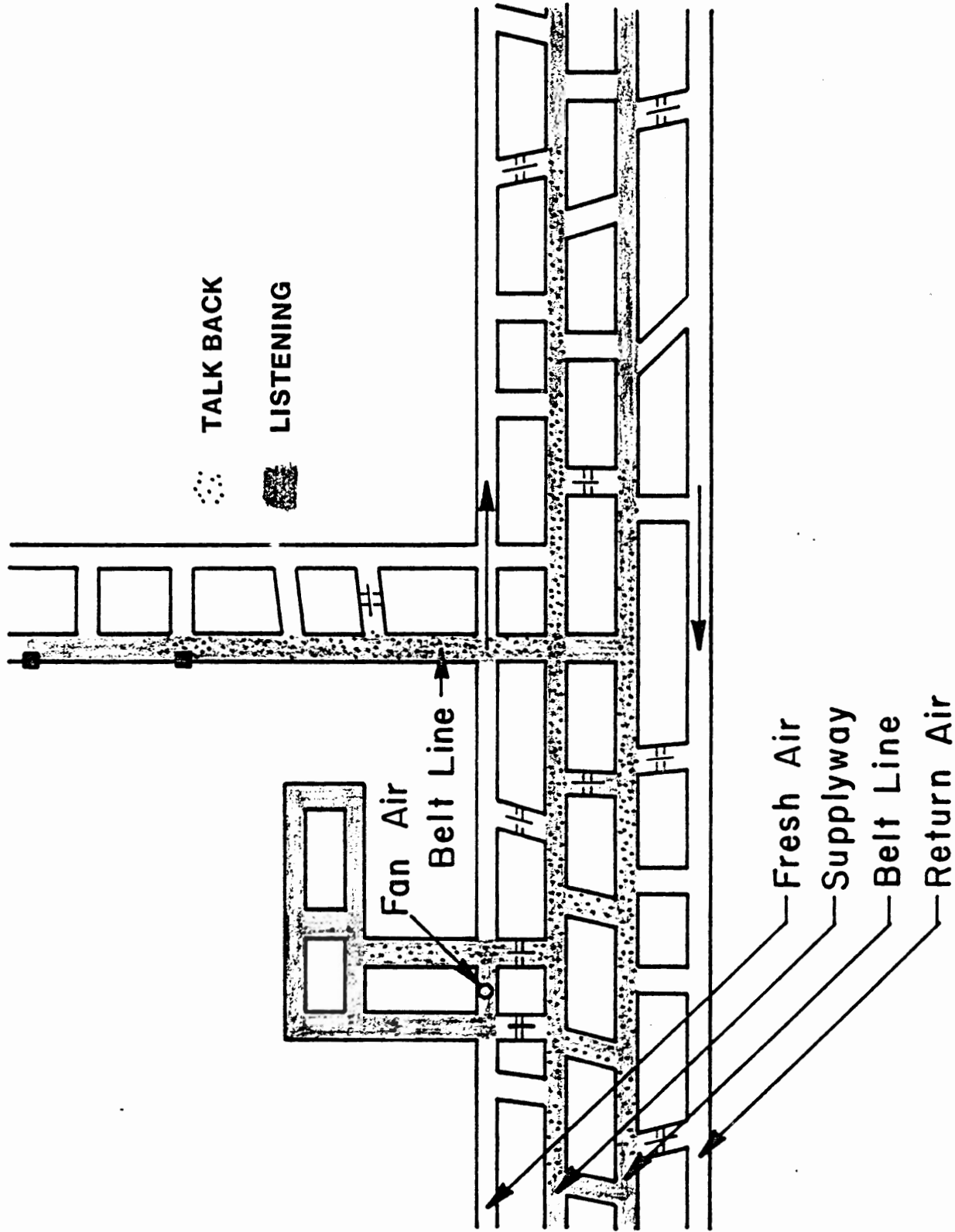

FIG. 76 NO. 31 CROSSCUT (3100 FEET)

The talkback (transmitting) range (dot symbol) included the manway and the beltway. It also extended along a feeder beltway. The listening (receiving) range (shaded area) extended into the drift adjacent to the manway. Note that range measurements were limited by sealed stoppings in the crosscuts.

FIGURE 77. RADIO COVERAGE AT CROSSCUT 91 ALONG MANWAY  
(9100 FEET FROM BASE STATION)



**FIG. 77 9 LEFT PANEL ( 9100 FEET )**

The Nine Left longwall entry is at crosscut 91. The longwall face is 5600 feet from the crosscut 91. A single pair telephone cable extends to the face in the entry. The talk back range is limited to the longwall entry. The total talk back range from the longwall face to the base is 14,700 feet. The listening range extends to drifts adjacent to the manway.

The surface telephone cable extends to the shop. The talk back range is limited to within 50 feet of the cable. The listening range limit is approximately 200 feet from the cable. The range includes the shop and office areas.

### 3. Mine Rescue Communications

The ability of rescue team members to communicate with MF radio was evaluated at the York Canyon Mine.

The single pair cable that is used by the mine rescue team for sound power audio communications was pulled from a take up reel and laid on the surface of the earth as shown in the following Figure 78.

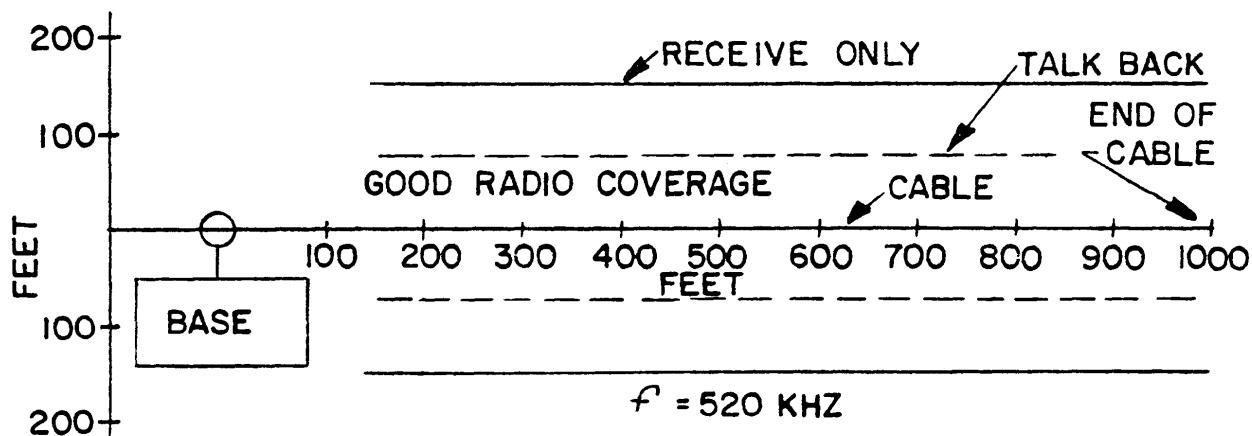

FIGURE 78. PLAN VIEW OF THE TRANSMISSION LINE AIDED RADIO COVERAGE (PAIR OF INSULATED #16 CONDUCTORS)



Range from the cable was maximum when the plane of the vest antenna was parallel to the cable. The base station induced signal was 100 dB greater than the line noise measured on the cable a few feet from the RF line coupler. The test clearly indicates that rescue team members with a permissible vest can communicate with the fresh air base station via the two pair cable.

Members of award winning mine rescue teams from the York Canyon Mine and the Colorado Westmoreland Mine near Paonia, Colorado, made a number of interesting observations concerning the use of MF radio. First, use of radio will revolutionize mine rescue procedures. The present life line communications cable is bulky and difficult to use. It is so onerous that it is not frequently used in mine rescue competition. The cable can be redesigned with a smaller diameter cable. This allows cables length to be greatly increased. As is the present practice, the team would lay the cable as they advance into the mine. When they arrive at a blocked entry (rock fall, hazardous environment), the cable can be simply cut and abandoned to hasten retreat. By simply splicing the cable, the team can advance along a new route. Secondly, the vest could be easily equipped with a telemetry capability to transmit local mine conditions immediately to the fresh air base station. A recorder at the base location could automatically record data. Finally, radio will speed recovery, an exceedingly important factor in successful rescues.

The use of MF radio by mine rescue teams is described in a USBM published report by Dobroski and Stolarczyk (29).

#### 4. Demonstration Results

With only four vehicular and four vest transceivers, radio communications is limited to supervisory personnel. On many occasions, the production superintendent used the radio to immediately summon emergency repair work on mining equipment. He estimates that the MF system reduces down time by more than one hour per shift.

Maintenance crew members use the vest transceivers in their work. The maintenance foreman uses the radio to communicate to the point of equipment breakdown. The foreman assists in troubleshooting and obtaining repair parts from the warehouse.

The mine superintendent is planning to install additional equipment on all service vehicles.

#### D. RANCHERS EXPLORATION AND DEVELOPMENT CORP.

The Redco Silver (Escalante Silver) Mine is owned and operated by Ranchers Exploration and Development Corp., 1775 Montano Road, N.W., Albuquerque, New Mexico. The mine is located in Iron County (42 miles west of Cedar City) Utah. The property has been known as the Holt Mine, The Enterprise Mine and The Escalante Mine. First claims were located in

1896 by Heber Holt. Between 1900 and 1930, three incline shafts were sunk on the vein (20', 30', and 130' deep) and one vertical shaft was sunk in the footwall to 120'. In 1959, the shaft was extended to the water table. First water draw-down test were made in 1960. Shipments of ore totalling 13,500 tons at 8.7 oz/T silver were made in 1966. The host rock are water-lain tuffaceous sediments of mid-tertiary age. The beds are composed of volcanic material with the composition of latite to rhyolite. The material is fine grained to conglomeratic, rounded to sub-rounded, and occurs in beds ranging from a few inches to 4 feet in thickness that dip  $10^{\circ}$  -  $15^{\circ}$  southwest. A cross cut of the ore body is shown in Figure 79.

FIGURE 79. REDCO SILVER ORE BODY

The vein strikes N25E and dips 70° - 75° west. Northwest trending fracture zones intersect the vein in two or more areas. The ore reserve portion of the vein averages 20 feet in thickness.

A modified vertical crater retreat (VCR) developed in Canada is used in the mining process. A plan view of VCR mining at the face is illustrated in Figure 80.

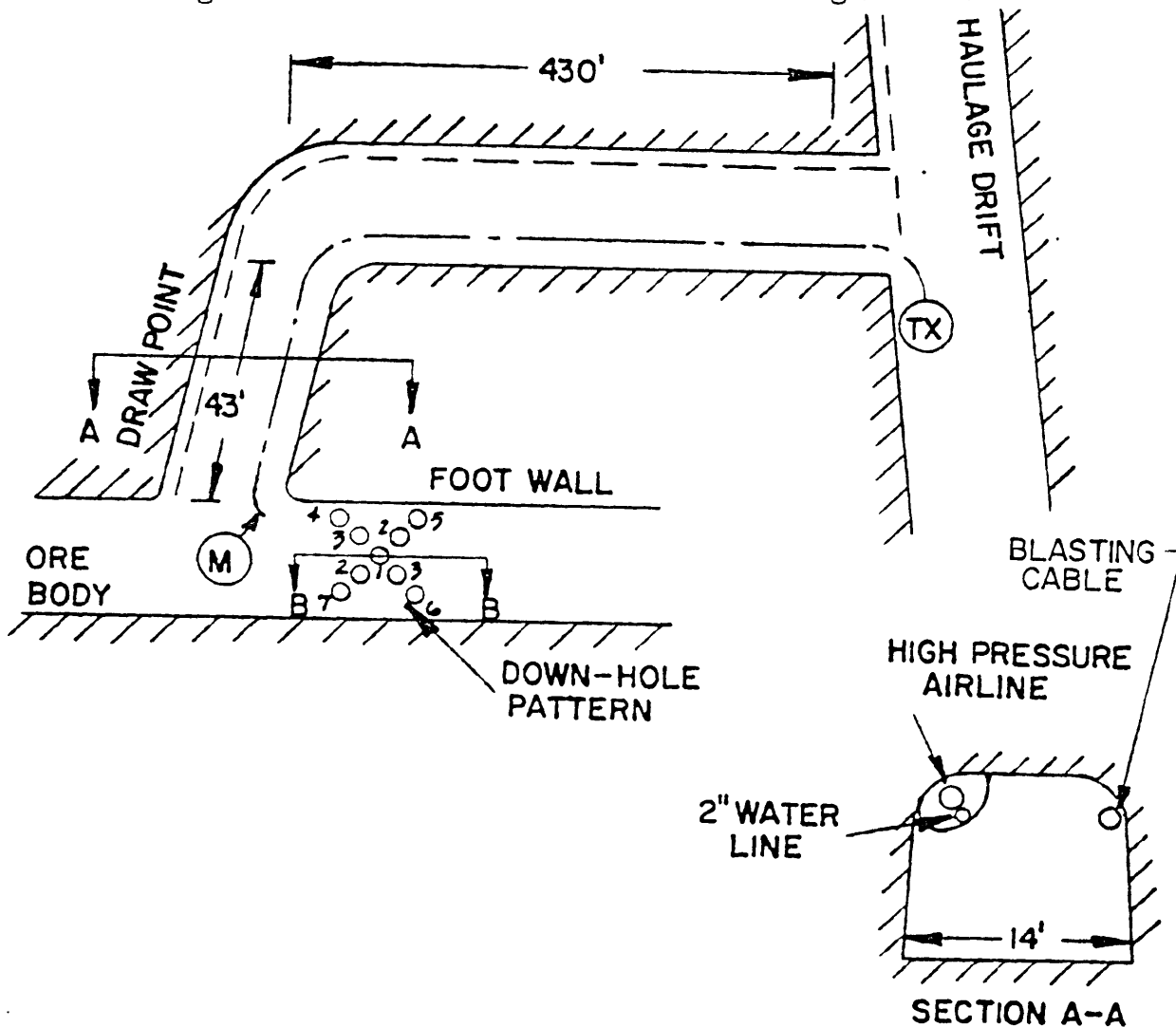

FIGURE 80. PLAN VIEW AND ENTRY CROSS SECTION OF THE 4970 LEVEL DRILL SUB-LEVEL NORTH UNDERCUT.

High pressure (250 psi) air line (dash line symbols) is suspended by chains from the left hand side of the roof in the drift. (See A-A' cross section view). Blasting cable (dashed-dot symbols) is suspended from hooks mounted on the wall of the drift. The blasting machine is connected to cable on the haulage drift (at the TX location). The cable is terminated in the blasting cap in the undercut (at the M location). Detonating cord connects the blasting cap to each of the nine (9) delay/booster/explosive charges in the drill holes. The blasting delay sequence is shown by the number next to the hole in the down-hole pattern.

The B-B' cross section of the down-hole pattern is shown in Figure 81.

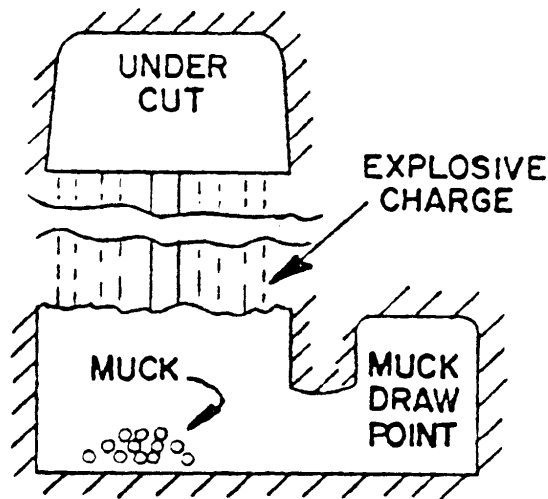

FIGURE 81. B-B' VIEW OF THE ORE BODY (VCR MINING)

1. Escalante Communication System

The Escalante radio communication system is shown in the block diagram below.

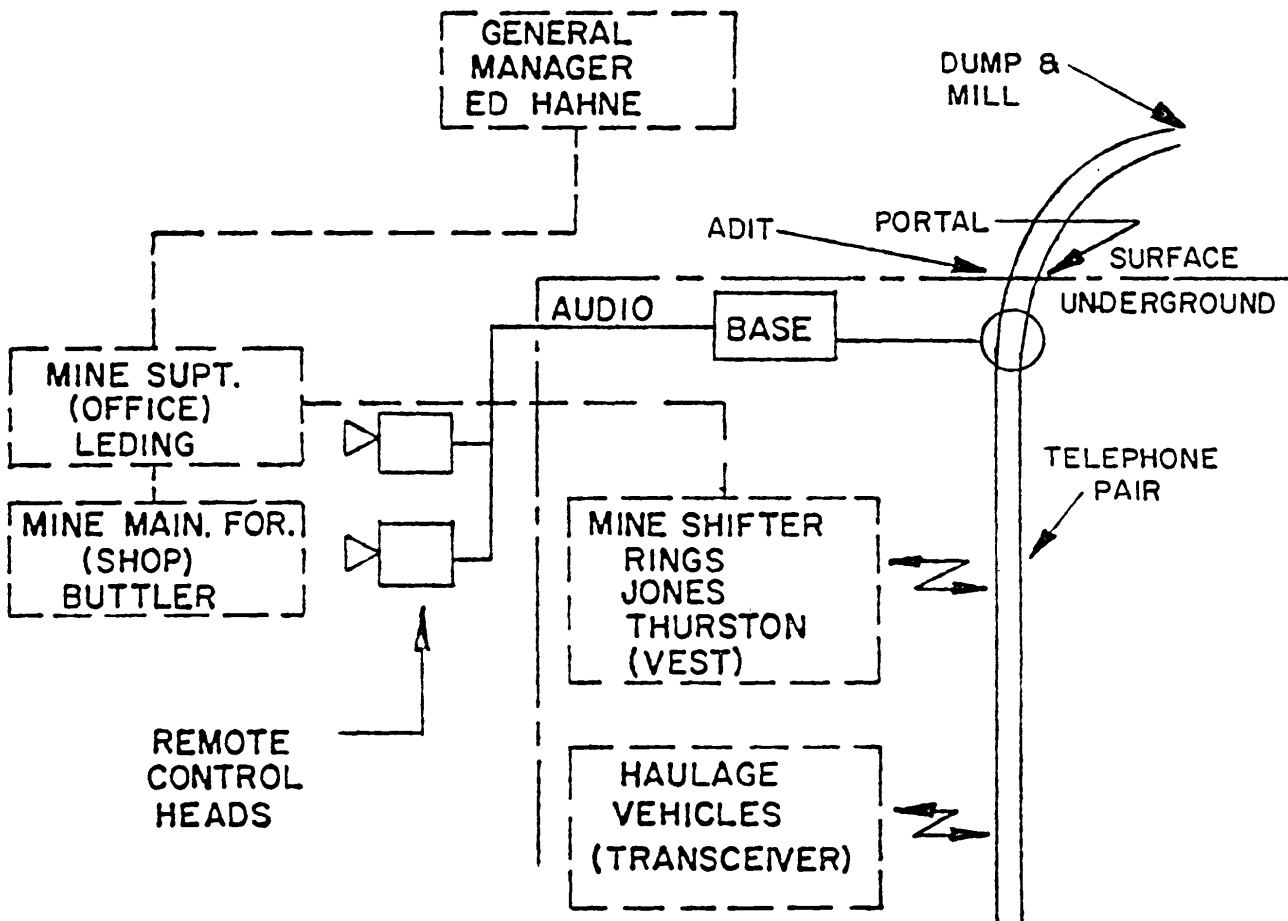

FIGURE 82. SYSTEM BLOCK DIAGRAM

The radio communications system block diagram overlays the organizational chart (shown by dashed block and connecting lines). The dashed lines show the existing communication paths. The shifter (front line foreman) insure that the mining process is carried out in an efficient and orderly manner. The shifters report to the mine superintendent (Mr. Leding).

Four diesel powered haulage vehicles are self dispatched in this mine. Up decline vehicles have the right-of-way to the dump. Round trip time on each vehicle is approximately 21 minutes. The per shift muck rate is 457 tons per haulage vehicle. Haulage cost increases because down-decline vehicles must frequently back-up to a turn-out to yield to the up-decline vehicle.

Vehicular radios were needed to enhance safety and productivity of muck haulage. Radio communications between the superintendent, shifter, and haulage vehicle driver were also needed to increase haulage efficiency. Since this is a small mine the maintenance and supervision networks were combined into one network ( $F_T = 400$  kHz).

## 2. Installation of MF Equipment

Figure 83 illustrates the haulage drift decline use to transport muck out of the mine.

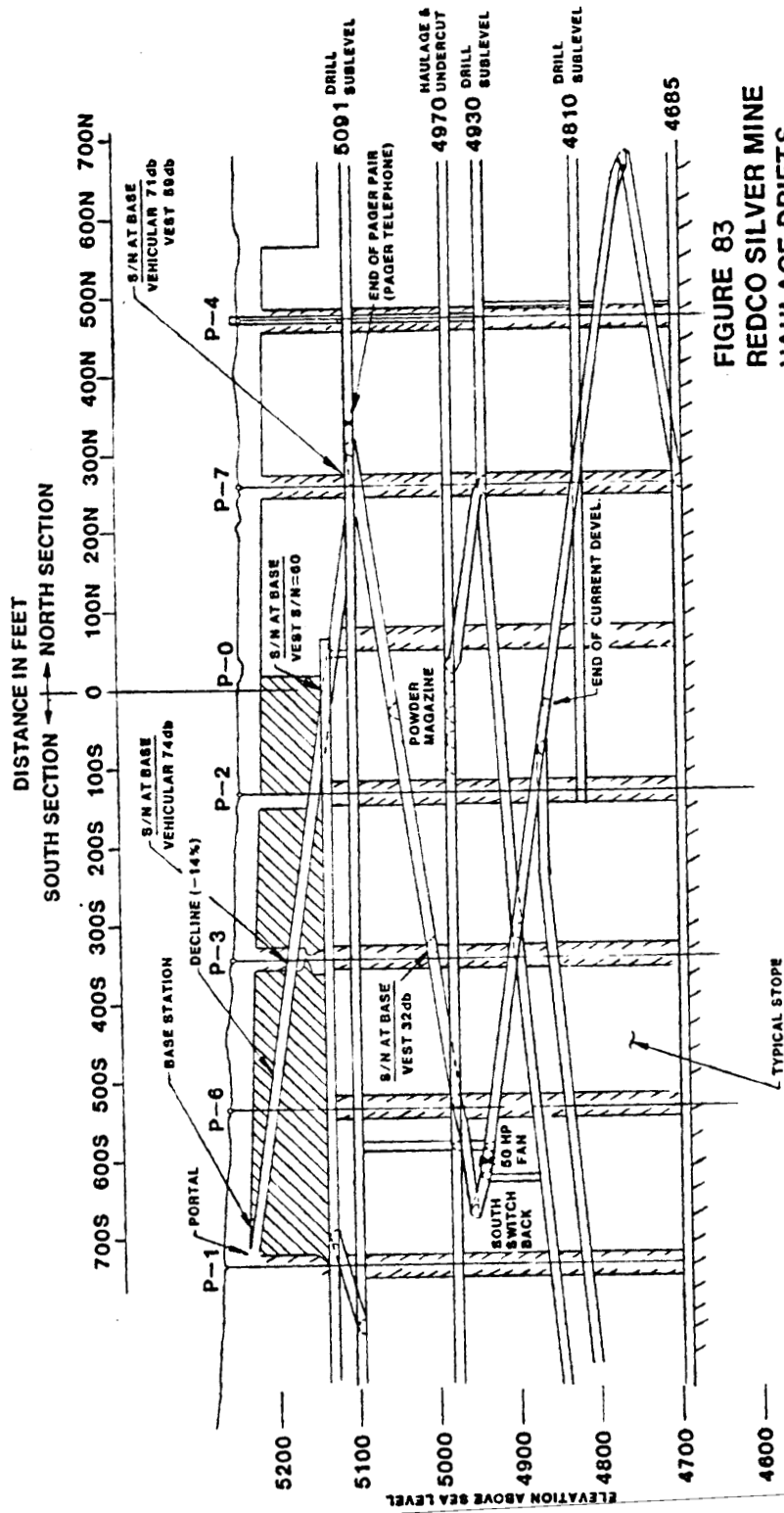
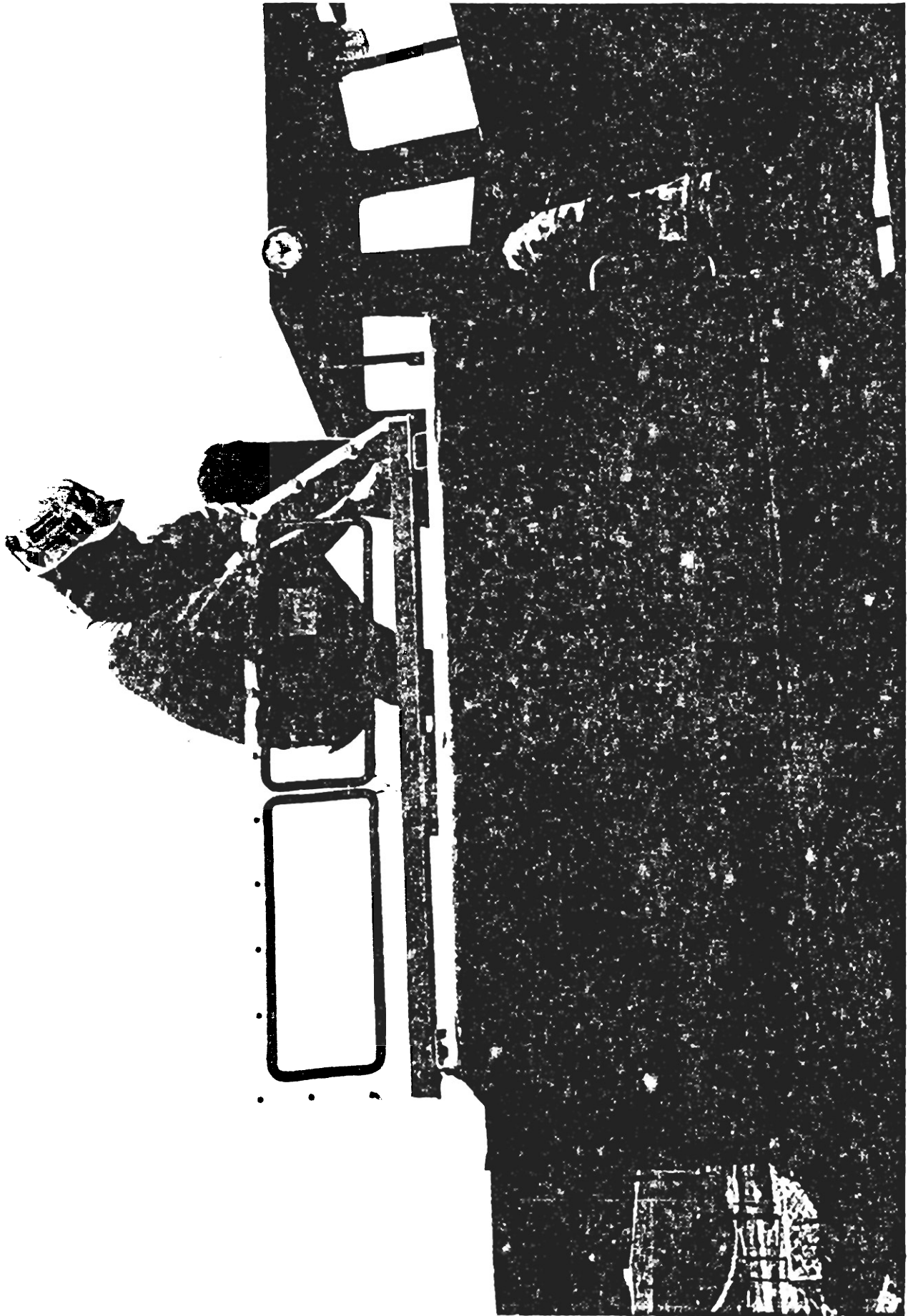

FIGURE 83  
 REDCO SILVER MINE  
 HAULAGE DRIFTS





An MF transceiver and antenna were mounted on each twenty ton Eimco\* haulage trucks.

FIGURE 84. EIMCO TRUCK SHOWING VEHICULAR ANTENNA

Because of the diesel truck engine noise, the truck driver uses the acoustical transducers shown in Figure 85.

\*Eimco Salt Lake City, Utah speakers with quick disconnect speaker cable.

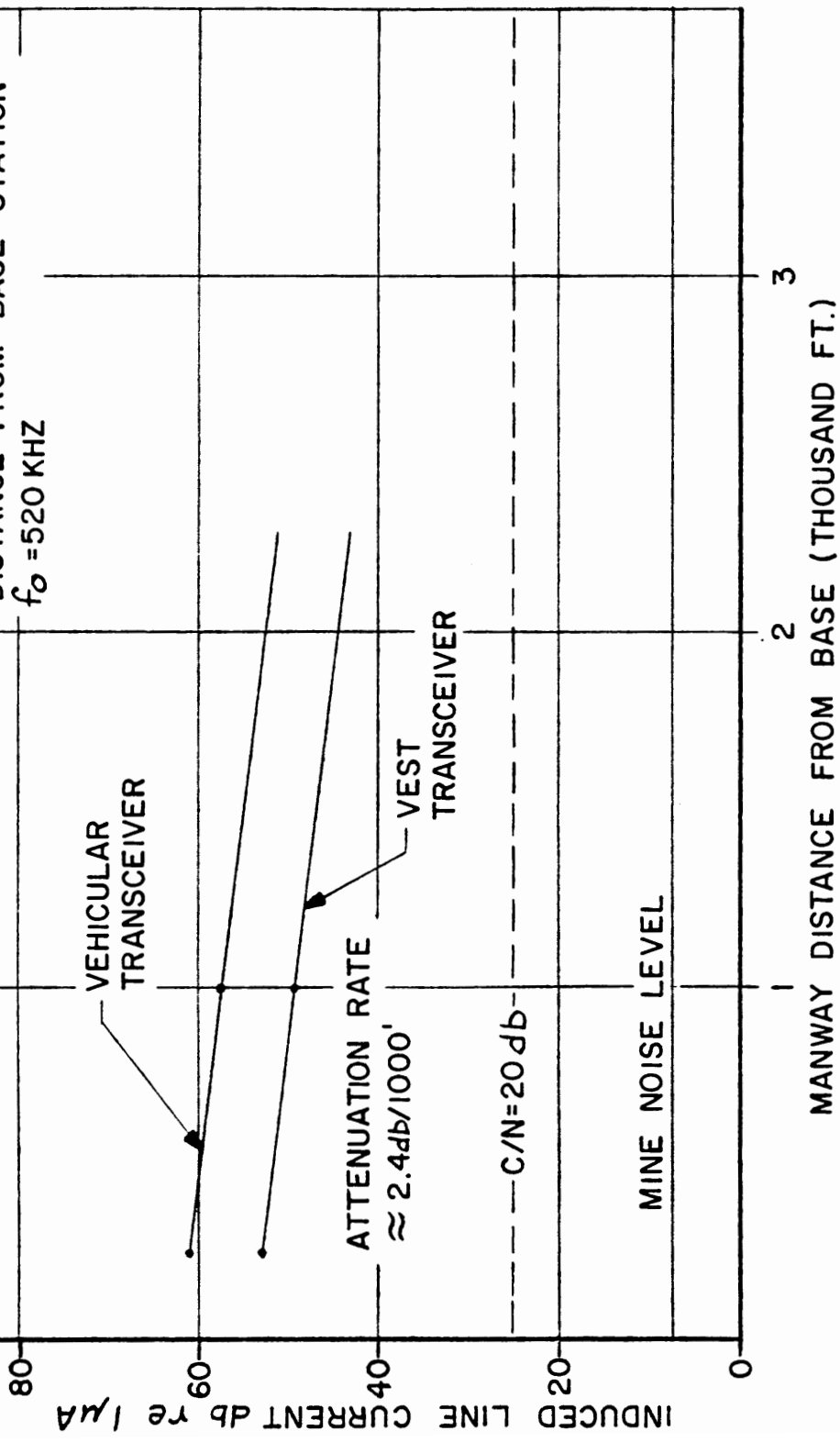

FIGURE 85. CIRCUM-AURAL EARCUPS

3. Field Test

In the initial installation, signals were measured at the base station. The measured signal levels are shown on Figure 83. A comparison of vehicular and vest signal levels are shown on Figure 86.

FIGURE 86  
 INDUCED LINE CURRENT  
 VERSUS VEHICULAR TRANSCIEIVER  
 DISTANCE FROM BASE STATION  
 $f_0 = 520 \text{ KHZ}$



The measured signal attenuation rate was approximately 2.4 dB/1000 feet along the telephone cable. The telephone cable terminated 1000 feet from the base station. High pressure air pipe continued to the drill level.

The carrier to noise ratio of received base station signals exceeded 32 dB for mobile transmissions along the pipe (beyond the end of the telephone pair). Test measurements revealed that the signal coupling loss between the telephone pair and air pipe in the same drift was approximately 30 dB.

The quality of the received voice signals was excellent. Base station messages could be received throughout the mine.

The acoustical noise level of the diesel engine exhaust system in the decline was high. Communications from moving diesel powered vehicles required the use of circum-aural ear-cups and noise cancelling microphones.

When the base station was exciting the "wireplant" the maximum signal measured in the blasting cable was 0.34 microamperes. A transmitting vehicular antenna next to the telephone pair could excite less than 1.2 milliamperes of line current. When the vehicular antenna was illuminated the sending-end of the blasting cable, the differential current in the terminal-end of the cable was less than 12 microamperes.

In summary, the worst case radio frequency radiation hazard safety factor was better than three (3) times less than the CFR safe limit of 50 milliamperes. Under normal operating conditions, the radiation hazard safety factor was better than 40 times less than the CFR limit.

Besides the high voice quality achieved in the system, the most noticable feature was the low attenuation rate of MF signals on the existing "wireplant". Low signal attenuation rate (2.4 dB/100') means that the system is capable of operations beyond 15,000 feet. This can be achieved without the use of a repeater.

## VII. RECOMMENDATIONS

The MF communications system is expected to emerge as the principal communications resource in mining.

The underground mine tests suggest the need to improve and add additional equipment to the MF system. The needs will be briefly described in the following paragraphs.

### A. BIDIRECTIONAL AMPLIFIER

Manways without conductors are usually adjacent to entries with conductors. Since twin-line cable must be installed in those manways, installation could be simplified if bidirectional amplifiers were available to provide an efficient interface with gain between the "wireplant" coupler and the twin-lead cable.

### B. REDUCE LOSS ACROSS AC POWER TRANSFORMERS AND SWITCHES

The AC power cable MF signal reliability can be improved by developing efficient couplers for use around high loss transformers and switches.

### C. BETTER WAYS TO DEPLOY TWIN-LEAD CABLE

Efficient methods of attaching twin-lead cable to the rib or roof should be developed for the system.

### D. TELEPHONE SYSTEM INTERFACE NETWORKS

Dial telephone capability should be added to the vest transceiver. This will enable the vest to operate as a Bell System compatible radio telephone.

## E. PAGING AND EMERGENCY COMMUNICATIONS

Since MF signals can be received everywhere electrical conductors exist, MF can be used for paging and emergency communications.

A low cost tone activated receiver should be made part of the cap lamp battery design. The MF receiver can be used in non-emergency situations to "page" and give miners vital information (even music - to insure that the miner will report a defective pager).

An illustration of the use of a cap lamp receiver is shown in Figure 87.

FIGURE 87. USE OF CAP LAMP RECEIVER FOR EMERGENCY COMMUNICATIONS



In emergency situations, evacuation routes can be given to underground miners. If trapped, the miner can receive MF signals and know that help is under way.

A tone oscillator can be added to the cap lamp to enable a trapped miner to signal to rescue teams. Figure 88 illustrates the use of the trapped miner transceiver.

FIGURE 88. LOCATION AND RESCUE BY MEDIUM FREQUENCY TECHNIQUES

In emergency situations, evacuation routes can be given to underground miners. If trapped, the miner can receive MF signals and know that help is under way.

A tone oscillator can be added to the cap lamp to enable a trapped miner to signal to rescue teams. Figure 88 illustrates the use of the trapped miner transceiver.

---

FIGURE 88. LOCATION AND RESCUE BY MEDIUM FREQUENCY TECHNIQUES

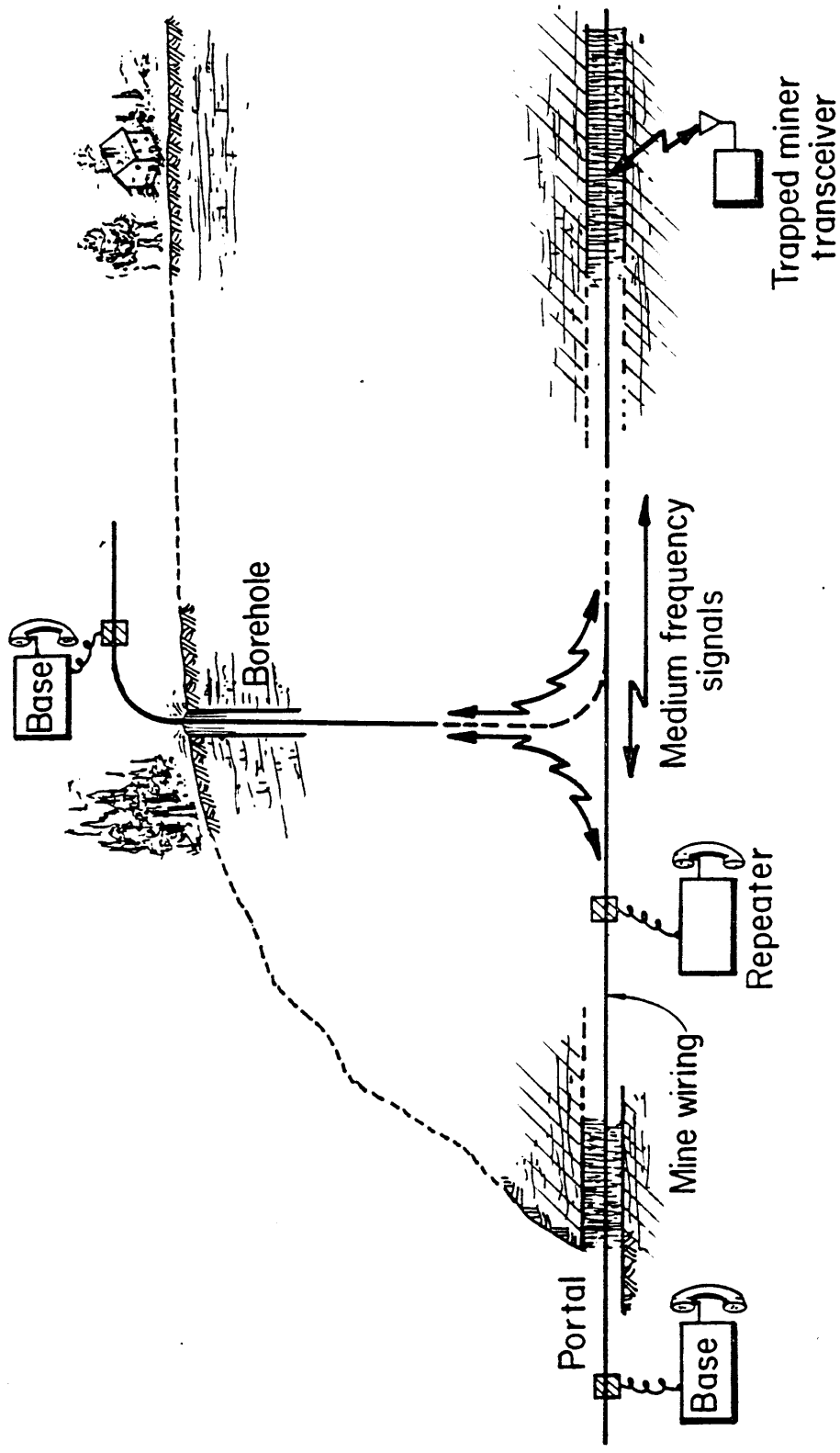

*LOCATION AND RESCUE BY  
MEDIUM FREQUENCY TECHNIQUES*

A base station at the portal can be used to communicate with a trapped miner. In the event that the portal base station has been rendered inoperable, for any reason, a base station and RF line coupler can be used to couple MF signals to bore hole conductors. Thus, bore hole base station can be used to communicate with trapped miners.

#### F. RESCUE TEAM COMMUNICATIONS

The vest transceiver will revolutionize mine rescue methods and speed recovery of the mine. The use of the vest transceiver by rescue team members is illustrated in Figure 89. Vest transceivers should be used for the communications man to inform the base of conditions encountered in the mission.

FIGURE 89. BASIC MF COMMUNICATIONS BETWEEN RESCUE TEAM MEMBERS.

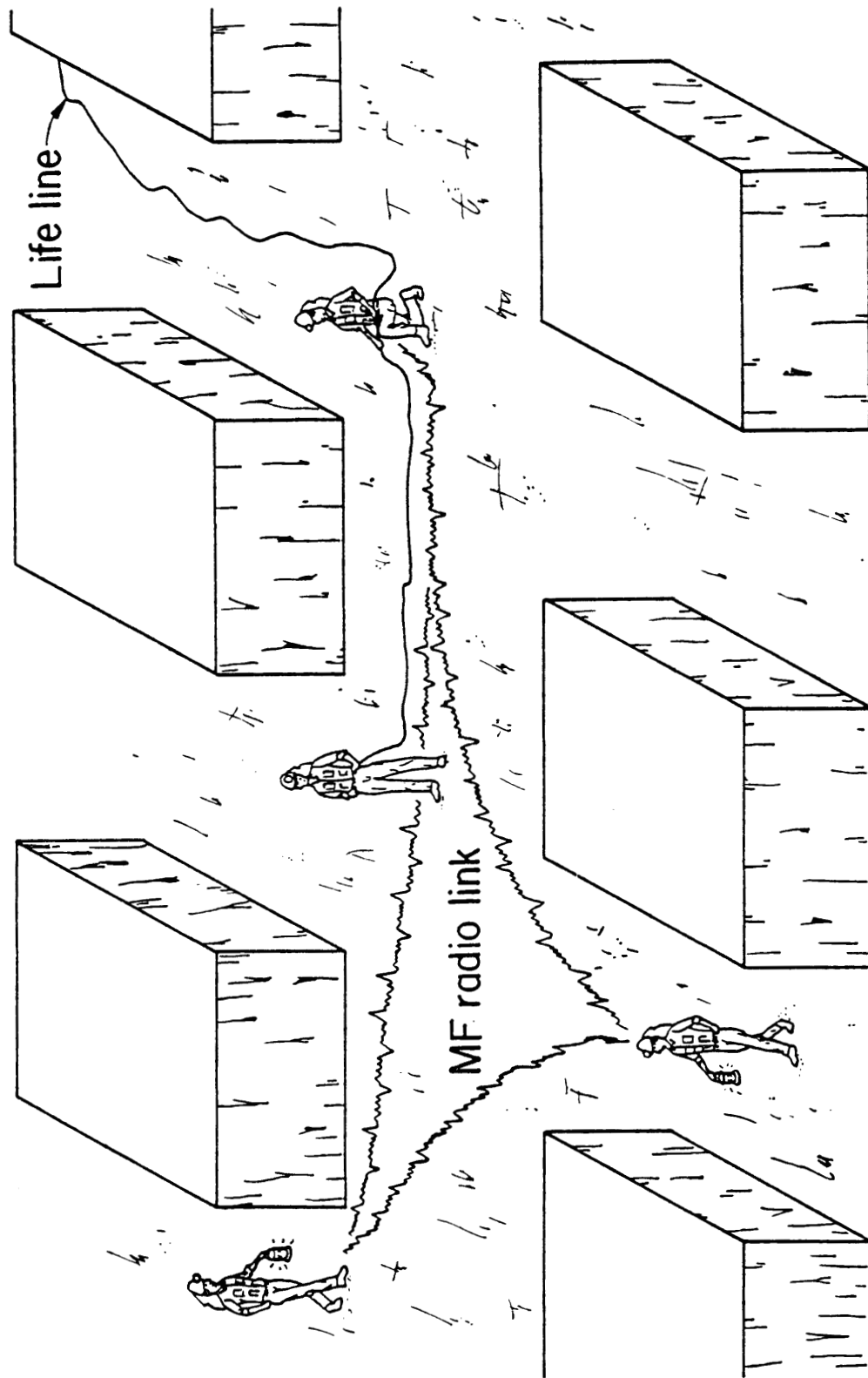

**BASIC MF COMMUNICATIONS  
BETWEEN RESCUE TEAM MEMBERS**

PGH-82  
585

As the rescue team advances from the fresh air base, a two conductor life line can be deployed as shown in the figure. The life line provides a reliable MF signal path between the fresh air base station and the rescue team. If a blocked or hazardous area is encountered by the rescue team, the life line can be left in place. The team can retreat along the line to an acceptable passageway. A branch of the life line can be connected to the original line to enable an MF signal path along the revised rescue team route.

Improved communications enable the team to rapidly determine entry conditions. By equipping the fresh air base with a tape recorder, the rescue record can be automatically recorded (logged).

The vest transceiver can be equipped with a telemetry module. Methane, CO, etc., monitor data can be immediately sent to the fresh air base. The briefing officer will be immediately aware of environmental conditions encountered by the rescue team.

#### G. HOIST COMMUNICATIONS

Hoist communications safety and reliability can be achieved with the MF radio equipment.

Hoist signalling microprocessors are required to enable transmission of the bell code and emergency signals.

Because the highly efficient vehicular antenna can be used at the collar to illuminate the wire rope, the MF system is much safer to maintain. MF equipment should be considered for hoist communications.

#### H. NATIONAL EMERGENCY FREQUENCY

The mine maintenance network and national rescue frequencies should be identical. The national rescue frequency is 400 kHz.

#### I. EMERGENCY COMMUNICATIONS

A vest transceiver should be assigned to each location of stored underground self-rescue breathing apparatus.

#### J. TRAINING MINE MANAGERS

Mine manager training seminar materials are needed to insure leadership in adopting the radio resource in mining.

APPENDIX A

NORMALIZED DISCRIMINATION  
LOSS (NORMALIZED ATTENUATION)  
OF THE  
LEGENDRE TRANSFER FUNCTION



NORMALIZED ATTENUATION LOSS IN DB OF THE LEGENDRE TRANSFER FUNCTION  
PASS BAND RIPPLE TOLERANCE 3 DB

| NORMALIZED<br>FREQUENCY | N=1    | N=2     | N=3     | N=4     | N=5     | N=6     | N=7     | N=8     | N=9     |
|-------------------------|--------|---------|---------|---------|---------|---------|---------|---------|---------|
| 0                       | .0000  | .9650   | .0000   | .5689   | .0000   | .4028   | .0000   | .3117   | .0000   |
| .05                     | .0108  | .9520   | .0240   | .5426   | .0370   | .3636   | .0491   | .2604   | .0604   |
| .10                     | .0430  | .9135   | .0930   | .4675   | .1361   | .2597   | .1687   | .1383   | .1890   |
| .15                     | .0962  | .8506   | .1981   | .3557   | .2668   | .1299   | .2932   | .0264   | .2779   |
| .20                     | .1695  | .7652   | .3263   | .2266   | .3907   | .0280   | .3573   | .0068   | .2539   |
| .25                     | .2621  | .6605   | .4623   | .1062   | .4722   | .0025   | .3261   | .0993   | .1331   |
| .30                     | .3726  | .5407   | .5904   | .0229   | .4872   | .0715   | .2118   | .2403   | .0175   |
| .35                     | .4996  | .4121   | .6957   | .0015   | .4277   | .2089   | .0744   | .3289   | .0204   |
| .40                     | .6417  | .2828   | .7652   | .0548   | .3056   | .3552   | .0009   | .2977   | .1513   |
| .45                     | .7974  | .1634   | .7883   | .1779   | .1560   | .4443   | .0526   | .1606   | .2906   |
| .50                     | .9650  | .0670   | .7573   | .3469   | .0348   | .4297   | .2101   | .0234   | .2996   |
| .55                     | 1.1430 | .0092   | .6690   | .5242   | .0034   | .3059   | .3743   | .0231   | .1553   |
| .60                     | 1.3299 | .0069   | .5269   | .6658   | .0996   | .1262   | .4280   | .1906   | .0092   |
| .65                     | 1.5244 | .0766   | .3455   | .7286   | .3053   | .0052   | .3123   | .3803   | .0714   |
| .70                     | 1.7251 | .2324   | .1573   | .6781   | .5413   | .0673   | .0964   | .3887   | .3087   |
| .75                     | 1.9308 | .4829   | .0213   | .4999   | .6913   | .3280   | .0050   | .1656   | .3975   |
| .80                     | 2.1404 | .8300   | .0276   | .2285   | .6403   | .6175   | .2414   | .0012   | .1499   |
| .85                     | 2.3530 | 1.2683  | .2834   | .0111   | .3391   | .6507   | .6160   | .3064   | .0328   |
| .90                     | 2.5676 | 1.7863  | .8714   | .1830   | .0073   | .2444   | .5486   | .6709   | .5534   |
| .95                     | 2.7835 | 2.3690  | 1.8004  | 1.1580  | .5625   | .1493   | .0005   | .0887   | .3008   |
| 1.00                    | 3.0000 | 3.0000  | 3.0000  | 3.0000  | 3.0000  | 3.0000  | 3.0000  | 3.0000  | 3.0000  |
| 1.10                    | 3.4326 | 4.3473  | 5.7986  | 7.7865  | 10.2360 | 13.0316 | 16.0648 | 19.2553 | 22.5514 |
| 1.20                    | 3.8617 | 5.7317  | 8.6453  | 12.3806 | 16.6293 | 21.1688 | 25.8771 | 30.6928 | 35.5834 |
| 1.30                    | 4.2846 | 7.0941  | 11.3001 | 16.3826 | 21.9130 | 27.6759 | 33.5767 | 39.5707 | 45.6335 |
| 1.40                    | 4.6993 | 8.4044  | 13.7200 | 19.8771 | 26.4207 | 33.1658 | 40.0365 | 46.9959 | 54.0223 |
| 1.50                    | 5.1046 | 9.6504  | 15.9222 | 22.9770 | 30.3752 | 37.9587 | 45.6625 | 53.4532 | 61.3100 |
| 1.60                    | 5.4997 | 10.8288 | 17.9361 | 25.7680 | 33.9144 | 42.2374 | 50.6782 | 59.2048 | 67.7971 |
| 1.70                    | 5.8842 | 11.9417 | 19.7897 | 28.3113 | 37.1284 | 46.1169 | 55.2217 | 64.4119 | 73.6675 |
| 1.80                    | 6.2579 | 12.9928 | 21.5065 | 30.6514 | 40.0790 | 49.6748 | 59.3861 | 69.1823 | 79.0438 |
| 1.90                    | 6.6209 | 13.9868 | 23.1059 | 32.8216 | 42.8110 | 52.9667 | 63.2373 | 73.5925 | 84.0129 |
| 2.00                    | 6.9732 | 14.9285 | 24.6034 | 34.8471 | 45.3581 | 56.0340 | 66.8244 | 77.6992 | 88.6390 |

NORMALIZED ATTENUATION LOSS IN DB OF THE LEGENDRE TRANSFER FUNCTION  
 PASS BAND TOLERANCE 3.000 DB

| NORMALIZED<br>FREQUENCY | N=1     | N=2     | N=3     | N=4     | N=5      | N=6      | N=7      | N=8      | N=9      |
|-------------------------|---------|---------|---------|---------|----------|----------|----------|----------|----------|
| 2.25                    | 7.8093  | 17.0828 | 27.9803 | 39.3977 | 51.0731  | 62.9116  | 74.8638  | 86.9001  | 99.0011  |
| 2.50                    | 8.5856  | 18.9978 | 30.9414 | 43.3752 | 56.0623  | 68.9115  | 81.8740  | 94.9204  | 108.0314 |
| 2.75                    | 9.3078  | 20.7199 | 33.5820 | 46.9154 | 60.4997  | 74.2454  | 88.1041  | 102.0466 | 116.0536 |
| 3.00                    | 9.9814  | 22.2640 | 35.9673 | 50.1095 | 64.5011  | 79.0536  | 93.7191  | 108.4682 | 123.2817 |
| 3.25                    | 10.6117 | 23.7165 | 38.1439 | 53.0218 | 68.1480  | 83.4349  | 98.8346  | 114.3179 | 129.8655 |
| 3.50                    | 11.2031 | 25.0379 | 40.1465 | 55.6997 | 71.5005  | 87.4618  | 103.5357 | 119.6932 | 135.9150 |
| 3.75                    | 11.7597 | 26.2644 | 42.0016 | 58.1792 | 74.6039  | 91.1890  | 107.8867 | 124.6678 | 141.5132 |
| 4.00                    | 12.2851 | 27.4086 | 43.7300 | 60.4886 | 77.4939  | 94.6595  | 111.9376 | 129.2990 | 146.7248 |
| 4.25                    | 12.7823 | 28.4811 | 45.3482 | 62.6502 | 80.1986  | 97.9071  | 115.7281 | 133.6325 | 151.6011 |
| 4.50                    | 13.2539 | 29.4904 | 46.8698 | 64.6822 | 82.7408  | 100.9595 | 119.2906 | 137.7050 | 156.1837 |
| 4.75                    | 13.7025 | 30.4436 | 48.3057 | 66.5995 | 85.1394  | 103.8392 | 122.6514 | 141.5469 | 160.5066 |
| 5.00                    | 14.1299 | 31.3466 | 49.6654 | 68.4147 | 87.4100  | 106.5651 | 125.8326 | 145.1834 | 164.5983 |
| 5.25                    | 14.5381 | 32.2045 | 50.9566 | 70.1383 | 89.5658  | 109.1531 | 128.8527 | 148.6356 | 168.4827 |
| 5.50                    | 14.9285 | 33.0216 | 52.1859 | 71.7791 | 91.6180  | 111.6166 | 131.7275 | 151.9218 | 172.1802 |
| 5.75                    | 15.3027 | 33.8017 | 53.3592 | 73.3449 | 93.5762  | 113.9673 | 134.4706 | 155.0572 | 175.7080 |
| 6.00                    | 15.6620 | 34.5480 | 54.4813 | 74.8423 | 95.4489  | 116.2151 | 137.0937 | 158.0554 | 179.0814 |
| 6.25                    | 16.0073 | 35.2633 | 55.5565 | 76.2771 | 97.2431  | 118.3689 | 139.6068 | 160.9280 | 182.3134 |
| 6.50                    | 16.3397 | 35.9500 | 56.5888 | 77.6544 | 98.9654  | 120.4361 | 142.0191 | 163.6853 | 185.4156 |
| 6.75                    | 16.6602 | 36.6105 | 57.5813 | 78.9786 | 100.6213 | 122.4237 | 144.3383 | 166.3361 | 188.3980 |
| 7.00                    | 16.9695 | 37.2467 | 58.5370 | 80.2538 | 102.2158 | 124.3375 | 146.5714 | 168.8885 | 191.2698 |
| 7.25                    | 17.2684 | 37.8602 | 59.4587 | 81.4834 | 103.7534 | 126.1829 | 148.7247 | 171.3497 | 194.0388 |
| 7.50                    | 17.5575 | 38.4526 | 60.3487 | 82.6707 | 105.2379 | 127.9647 | 150.8037 | 173.7259 | 196.7122 |
| 7.75                    | 17.8375 | 39.0255 | 61.2091 | 83.8184 | 106.6730 | 129.6871 | 152.8134 | 176.0229 | 199.2965 |
| 8.00                    | 18.1088 | 39.5799 | 62.0418 | 84.9292 | 108.0618 | 131.3539 | 154.7583 | 178.2458 | 201.7974 |
| 8.25                    | 18.3721 | 40.1171 | 62.8485 | 86.0053 | 109.4073 | 132.9688 | 156.6424 | 180.3993 | 204.2203 |
| 8.50                    | 18.6277 | 40.6382 | 63.6309 | 87.0489 | 110.7121 | 134.5348 | 158.4696 | 182.4876 | 206.5698 |
| 8.75                    | 18.8762 | 41.1440 | 64.3903 | 88.0619 | 111.9786 | 136.0548 | 160.2431 | 184.5147 | 208.8503 |
| 9.00                    | 19.1178 | 41.6354 | 65.1281 | 89.0460 | 113.2090 | 137.5315 | 161.9661 | 186.4839 | 211.0658 |
| 9.25                    | 19.3529 | 42.1132 | 65.8456 | 90.0029 | 114.4053 | 138.9672 | 163.6413 | 188.3985 | 213.2199 |
| 9.50                    | 19.5819 | 42.5782 | 66.5437 | 90.9340 | 115.5694 | 140.3643 | 165.2713 | 190.2616 | 215.3159 |
| 9.75                    | 19.8051 | 43.0311 | 67.2235 | 91.8407 | 116.7030 | 141.7247 | 166.8586 | 192.0757 | 217.3569 |
| 10.00                   | 20.0228 | 43.4724 | 67.8859 | 92.7242 | 117.8075 | 143.0504 | 168.4053 | 193.8434 | 219.3457 |

APPENDIX B  
DISSIPATION LOSS  
OF THE  
LEGENDRE TRANSFER FUNCTION

AMPLITUDE DETERIORATION IN DB AT ZERO FREQUENCY OF THE LEGENDRE FILTER WITH EQUAL ELEMENT Q

3.000 DB PASS BAND TOLERANCE

| ELEMENT Q | N=1     | N=2      | N=3      | N=4      | N=5      | N=6      | N=7      | N=8      | N=9       |
|-----------|---------|----------|----------|----------|----------|----------|----------|----------|-----------|
| .5        | 9.52868 | 18.86149 | 31.09586 | 42.16253 | 54.57493 | 66.14549 | 78.61058 | 90.42578 | 102.91359 |
| 1.0       | 6.01029 | 11.02112 | 18.64128 | 25.03988 | 32.74031 | 39.57080 | 47.27573 | 54.51566 | 62.01641  |
| 1.5       | 4.42873 | 7.62930  | 13.21124 | 17.53295 | 23.11993 | 27.81817 | 33.37669 | 38.26011 | 43.79647  |
| 2.0       | 3.51496 | 5.77219  | 10.21047 | 13.38664 | 17.79385 | 21.30336 | 25.66242 | 29.34015 | 33.66551  |
| 2.5       | 2.91667 | 4.61575  | 8.31931  | 10.78343 | 14.44249 | 17.20376 | 20.80433 | 23.72064 | 27.28032  |
| 3.0       | 2.49362 | 3.83262  | 7.02137  | 9.00704  | 12.14911 | 14.40059 | 17.47996 | 19.87514 | 22.90950  |
| 3.5       | 2.17831 | 3.27051  | 6.07594  | 7.72193  | 10.48419 | 12.36863 | 15.06779 | 17.08565 | 19.73787  |
| 4.0       | 1.93408 | 2.84850  | 5.35656  | 6.75124  | 9.22160  | 10.83082 | 13.23992 | 14.97306 | 17.33481  |
| 4.5       | 1.73926 | 2.52083  | 4.79067  | 5.99333  | 8.23154  | 9.62787  | 11.80790 | 13.31933 | 15.45261  |
| 5.0       | 1.58019 | 2.25946  | 4.33877  | 5.38583  | 7.43444  | 8.66198  | 10.65606 | 11.99055 | 13.93918  |
| 5.5       | 1.44784 | 2.04637  | 3.95702  | 4.88843  | 6.77888  | 7.86987  | 9.70965  | 10.90007 | 12.69613  |
| 6.0       | 1.33599 | 1.86944  | 3.64097  | 4.47395  | 6.23020  | 7.20883  | 8.91826  | 9.98943  | 11.65709  |
| 6.5       | 1.24021 | 1.72028  | 3.37198  | 4.12342  | 5.76417  | 6.64904  | 8.24668  | 9.21777  | 10.77571  |
| 7.0       | 1.15726 | 1.59290  | 3.14024  | 3.82322  | 5.36339  | 6.16903  | 7.66960  | 8.55569  | 10.01866  |
| 7.5       | 1.08473 | 1.48289  | 2.93847  | 3.56332  | 5.01503  | 5.75301  | 7.16837  | 7.98153  | 9.36137   |
| 8.0       | 1.02076 | 1.38695  | 2.76120  | 3.33617  | 4.70939  | 5.38904  | 6.72893  | 7.47894  | 8.78533   |
| 8.5       | .96392  | 1.30256  | 2.60420  | 3.13599  | 4.43906  | 5.06799  | 6.34051  | 7.03540  | 8.27634   |
| 9.0       | .91309  | 1.22776  | 2.46417  | 2.95827  | 4.19823  | 4.78274  | 5.99468  | 6.64113  | 7.82333   |
| 9.5       | .86735  | 1.16103  | 2.33850  | 2.79946  | 3.98231  | 4.52764  | 5.68480  | 6.28838  | 7.41753   |
| 10.0      | .82598  | 1.10113  | 2.22507  | 2.65671  | 3.76761  | 4.29818  | 5.40551  | 5.97096  | 7.05192   |
| 10.5      | .78838  | 1.04707  | 2.12218  | 2.52772  | 3.61115  | 4.09070  | 5.15250  | 5.68383  | 6.72080   |
| 11.0      | .75405  | .99804   | 2.02842  | 2.41059  | 3.45046  | 3.90220  | 4.92222  | 5.42288  | 6.41949   |
| 11.5      | .72260  | .95337   | 1.94261  | 2.30377  | 3.30352  | 3.73020  | 4.71172  | 5.18469  | 6.14415   |
| 12.0      | .69366  | .91250   | 1.86380  | 2.20596  | 3.16863  | 3.57263  | 4.51855  | 4.96643  | 5.89155   |
| 12.5      | .66695  | .87498   | 1.79115  | 2.11608  | 3.04437  | 3.42776  | 4.34066  | 4.76570  | 5.65897   |
| 13.0      | .64222  | .84041   | 1.72396  | 2.03320  | 2.92951  | 3.29413  | 4.17630  | 4.58048  | 5.44412   |
| 13.5      | .61926  | .80845   | 1.66165  | 1.95653  | 2.82304  | 3.17046  | 4.02397  | 4.40904  | 5.24504   |
| 14.0      | .59789  | .77883   | 1.60369  | 1.88541  | 2.72405  | 3.05571  | 3.88240  | 4.24991  | 5.06006   |
| 14.5      | .57794  | .75129   | 1.54965  | 1.81926  | 2.63180  | 2.94893  | 3.75049  | 4.10182  | 4.88773   |
| 15.0      | .55929  | .72563   | 1.49914  | 1.75758  | 2.54560  | 2.84933  | 3.62727  | 3.96365  | 4.72678   |
| 15.5      | .54180  | .70166   | 1.45183  | 1.69992  | 2.46489  | 2.75621  | 3.51192  | 3.83445  | 4.57613   |
| 16.0      | .52537  | .67921   | 1.40741  | 1.64591  | 2.38916  | 2.66896  | 3.40370  | 3.71337  | 4.43482   |
| 16.5      | .50990  | .65815   | 1.36564  | 1.59522  | 2.31794  | 2.58705  | 3.30196  | 3.59967  | 4.30199   |
| 17.0      | .49533  | .63836   | 1.32628  | 1.54755  | 2.25087  | 2.50999  | 3.20615  | 3.49270  | 4.17692   |
| 17.5      | .48156  | .61971   | 1.28913  | 1.50263  | 2.18757  | 2.43738  | 3.11576  | 3.39189  | 4.05893   |
| 18.0      | .46854  | .60213   | 1.25401  | 1.46024  | 2.12774  | 2.36883  | 3.03034  | 3.29671  | 3.94744   |
| 18.5      | .45620  | .58551   | 1.22076  | 1.42017  | 2.07111  | 2.30402  | 2.94949  | 3.20670  | 3.84193   |
| 19.0      | .44450  | .56978   | 1.18922  | 1.38223  | 2.01742  | 2.24266  | 2.87285  | 3.12147  | 3.74193   |
| 19.5      | .43338  | .55487   | 1.15928  | 1.34626  | 1.96645  | 2.18447  | 2.80010  | 3.04063  | 3.64701   |
| 20.0      | .42280  | .54072   | 1.13080  | 1.31212  | 1.91799  | 2.12921  | 2.73095  | 2.96386  | 3.55680   |

AMPLITUDE DETERIORATION IN DB AT ZERO FREQUENCY OF THE LEGENDRE FILTER WITH EQUAL ELEMENT Q

3.000 DB PASS BAND TOLERANCE

| ELEMENT Q | N=1     | N=2     | N=3     | N=4     | N=5     | N=6     | N=7      | N=8      | N=9      |
|-----------|---------|---------|---------|---------|---------|---------|----------|----------|----------|
| 5.0       | 1.58019 | 2.25946 | 4.33377 | 5.38583 | 7.43444 | 8.66198 | 10.65606 | 11.99055 | 13.93918 |
| 10.0      | .82598  | 1.10113 | 2.22507 | 2.65671 | 3.78761 | 4.29818 | 5.40551  | 5.97096  | 7.05192  |
| 15.0      | .55929  | .72563  | 1.49914 | 1.75758 | 2.54560 | 2.84933 | 3.62727  | 3.96365  | 4.72678  |
| 20.0      | .42280  | .54072  | 1.13080 | 1.31212 | 1.91799 | 2.12921 | 2.73095  | 2.96386  | 3.55680  |
| 25.0      | .33987  | .43081  | .90789  | 1.04650 | 1.53895 | 1.69911 | 2.19034  | 2.36605  | 2.85181  |
| 30.0      | .28414  | .35800  | .75844  | .87021  | 1.28512 | 1.41336 | 1.82860  | 1.96860  | 2.38036  |
| 35.0      | .24412  | .30622  | .65126  | .74471  | 1.10322 | 1.20980 | 1.56950  | 1.68534  | 2.04281  |
| 40.0      | .21397  | .26752  | .57063  | .65082  | .96645  | 1.05744 | 1.37476  | 1.47326  | 1.78917  |
| 45.0      | .19046  | .23750  | .50777  | .57794  | .85987  | .93915  | 1.22304  | 1.30856  | 1.59160  |
| 50.0      | .17160  | .21354  | .45739  | .51973  | .77447  | .84464  | 1.10149  | 1.17695  | 1.43335  |
| 55.0      | .15614  | .19397  | .41611  | .47217  | .70451  | .76741  | 1.00193  | 1.06938  | 1.30374  |
| 60.0      | .14323  | .17768  | .38166  | .43258  | .64614  | .70311  | .91888   | .97982   | 1.19563  |
| 65.0      | .13230  | .16391  | .35248  | .39911  | .59671  | .64875  | .84855   | .90410   | 1.10409  |
| 70.0      | .12292  | .15213  | .32745  | .37045  | .55430  | .60219  | .78822   | .83923   | 1.02557  |
| 75.0      | .11478  | .14192  | .30574  | .34563  | .51752  | .56186  | .73590   | .78305   | .95748   |
| 80.0      | .10765  | .13300  | .28672  | .32393  | .48532  | .52659  | .69010   | .73392   | .89787   |
| 85.0      | .10135  | .12513  | .26994  | .30479  | .45689  | .49549  | .64967   | .69058   | .84525   |
| 90.0      | .09575  | .11815  | .25501  | .28778  | .43161  | .46786  | .61371   | .65208   | .79846   |
| 95.0      | .09074  | .11190  | .24164  | .27258  | .40898  | .44314  | .58152   | .61764   | .75658   |
| 100.0     | .08622  | .10628  | .22961  | .25889  | .38861  | .42091  | .55255   | .58666   | .71887   |
| 150.0     | .05758  | .07074  | .15328  | .17237  | .25939  | .26027  | .36879   | .39067   | .47977   |
| 200.0     | .04322  | .05301  | .11504  | .12919  | .19467  | .21008  | .29283   | .36003   | .47977   |
| 250.0     | .03459  | .04239  | .09207  | .10331  | .15579  | .16800  | .22148   | .23419   | .28813   |
| 300.0     | .02804  | .03531  | .07675  | .08607  | .12986  | .13996  | .18461   | .19511   | .24016   |
| 350.0     | .02472  | .03026  | .06580  | .07376  | .11133  | .11995  | .15827   | .16721   | .20589   |
| 400.0     | .02164  | .02647  | .05750  | .06453  | .09743  | .10494  | .13650   | .14629   | .18017   |
| 450.0     | .01923  | .02353  | .05119  | .05735  | .08661  | .09327  | .12313   | .13002   | .16017   |
| 500.0     | .01731  | .02117  | .04607  | .05161  | .07796  | .08394  | .11082   | .11701   | .14416   |
| 550.0     | .01574  | .01925  | .04189  | .04692  | .07087  | .07630  | .10075   | .10636   | .13107   |
| 600.0     | .01443  | .01764  | .03840  | .04301  | .06497  | .06994  | .09236   | .09750   | .12015   |
| 650.0     | .01332  | .01628  | .03545  | .03970  | .05998  | .06456  | .08526   | .08999   | .11091   |
| 700.0     | .01237  | .01512  | .03292  | .03686  | .05569  | .05994  | .07918   | .08356   | .10300   |
| 750.0     | .01155  | .01411  | .03072  | .03440  | .05198  | .05594  | .07390   | .07799   | .09613   |
| 800.0     | .01082  | .01323  | .02881  | .03225  | .04874  | .05245  | .06928   | .07311   | .09013   |
| 850.0     | .01019  | .01245  | .02711  | .03035  | .04587  | .04936  | .06521   | .06881   | .08483   |
| 900.0     | .00962  | .01176  | .02561  | .02866  | .04332  | .04662  | .06159   | .06498   | .08012   |
| 950.0     | .00912  | .01114  | .02426  | .02715  | .04104  | .04416  | .05835   | .06156   | .07590   |
| 1000.0    | .00866  | .01058  | .02305  | .02580  | .03899  | .04195  | .05543   | .05848   | .07211   |

APPENDIX C

3 dB LEGENDRE FILTER ELEMENT  
VALUES

Legendre Filter Element Values

| N | L <sub>1</sub> , or C <sub>1</sub> ' | C <sub>2</sub> or L <sub>2</sub> ' | L <sub>3</sub> or C <sub>3</sub> ' | C <sub>4</sub> or L <sub>4</sub> ' | C <sub>5</sub> or C <sub>5</sub> ' |
|---|--------------------------------------|------------------------------------|------------------------------------|------------------------------------|------------------------------------|
| 1 | 1.99                                 |                                    |                                    |                                    |                                    |
| 3 | 2.075                                | 1.158                              | 2.075                              |                                    |                                    |
| 5 | 1.865                                | 1.310                              | 2.631                              | 1.310                              | 1.865                              |

## LIST OF REFERENCES

1. McCarthy, J.E., Basic Marketing, Richard D. Irwin, Inc., Homewood, Illinois 60430; 1971.
2. Pugh, D.S., Organization Theory, Penguin Modern Management Reading; 1971.
3. Stolarczyk, L.G., "The Image - The Keystone to a Profitable CB Business", Personal Communications; 1978.
4. Mayo, E., "Hawthorne and the Western Electric Company", The Social Problems of an Industrial Civilization, Routhledge, Chapter 4, pp. 60-76; 1949.
5. Bavelas, A., "A Mathematical Model for Group Structure", Applied Anthropology, Vol. 7, pp. 16-30; 1948.
6. Trist, E.L., and Bamforth, K.W., "Some Social and Psychological Consequences of Longwall Method of Coal-Betting", Human Relations Vol. No. 1, pp. 1-24; 1941.
7. Leavit, H.J., "Some Effects of Certain Communication Patterns on Group Performance", Journal of Abnormal and Social Psychology, No. 48, pp. 38-50; 1951.
8. Lohman, G.M., "A Closed Network Queue Model of Underground Coal Mining, Production, Failure, and Repair", Jet Propulsion Laboratory, California Institute of Technology, Pasadena, CA, Pub. 78-72, August 1978.



9. Marrus, L.D., etal., "Logistic Performance of Continuous Miners", Final Report No. 4185, Contract No. SO 144057, U.S.B.M., January 1976.
10. Dr. John Smoker, Medical Officer for Kaiser Steel York Canyon Mine, Raton, New Mexico.
11. Skinner, Wickham, "The Focused Factory".
12. Sacks, H.K., and Chufo, R.L., "Medium Frequency Propagation in Coal Mines", Proceedings, Fourth WVU Conference on Coal Mines Electrotechnology, August 1978.
13. Emslie, A.G., and Lagace, R.L., "Medium Frequency Radio Propagation and Coupling in Coal Mines", Proceedings, Electromagnetic Guided Waves in Mine Environments Workshop, Boulder, Colo., March 1978. (U.S.B.M. Contract HO 155008).
14. Lagace, R.L., Task Leader, Transmit Antennas for Portable VLF to MF Wireless Mine Communications, U.S.B.M. Contract HO 346045, Task C, Task Order No. 1, May 1977. Arthur D. Little Inc., Cambridge, Mass.
15. Hill, D.A., and Wait, J.R., "Excitation of Monofilar and Bifilar Modes on a Transmission Line in a Circular Tunnel", Journal of Applied Physics, Vol. 45, No. 8, August 1974.

16. Scott, et al, "Electromagnetic Noise in McElroy Mine",  
Electromagnetic Division, Institute for Basic  
Standards, NBS, Boulder, Colo. 74-389.
17. Kanda, M., et al, Electromagnetic Noise in McElroy  
Mine, A Technical Report of Electromagnetics Division,  
Institute for Basic Standards, National Bureau of  
Standards, Boulder, Colo. 80302, June 1974.
18. Stolarczyk, L.G., and Chufo, R.L., "Medium Frequency  
"Near" Magnetic Field Wireless Communication System"  
Modulation Processes, Fifth WVU Conference on Coal  
Mine Electrotechnology; August 1980.
19. Austin, B.A., "Underground Radio Communication Techniques  
and Systems in South African Mines". Proceedings,  
Electromagnetic Guided Waves in Mine Environments  
Workshop, Golden, Colo., 1978, pp. 87-102.
20. Collins Commercial Telecommunications. Electromagnetic  
Noise and Propagation in Low Coal Mines at Medium  
Frequencies. Contract HO 377053. BuMines Open File  
No. 63-82, 1982, 94 pp.; available for consultation  
at the Bureau of Mines libraries in Pittsburgh, Pa.,  
Denver, Colo., Spokane, Wash., Twin Cities, Minn., and  
Morgantown, W. Va.; and at the Central Library, U.S.  
Department of the Interior, Washington, D.C. Printed  
copy available from the National Technical Information  
Service, Springfield, Va. 22161, NTIS No. PB 82-202656.

21. Lagace, R.L., Emsile, A.G., and Grossman, M.A., Modelling and Data Analysis of 50 to 5,000 kHz Radio Wave Propagation in Coal Mines, Task Order 4 BuMines Contract HO 346045, Arthur D. Little, Inc. BuMines Open File Rept. 83-80, 1980, 109 pp.; available for consultation at the Bureau of Mines libraries in Pittsburgh, Pa., Denver, Colo., Spokane, Wash., Twin Cities, Minn., and Morgantown, W. Va.; and at the Central Library, U.S. Department of the Interior, Washington, D.C. Printed copy available from the National Technical Information Service, Springfield, Va. 22161, PB 80-209455.
  
22. Cory, T.S., Propagation of EM Signal in Underground Mines. BuMines Contract HO 366028, Collins Radio Group. BuMines Open File Rept. 136-78, 1977, 158 pp.; available for consultation at the Bureau of Mines libraries in Pittsburgh, Pa., Denver, Colo., Spokane, Wash., Twin Cities, Minn., and Morgantown, W. Va.; and at the Central Library, U.S. Department of the Interior, Washington, D.C. Printed copy available from the National Technical Information Service, Springfield, Va. 22161, PB 289 757/AS.

23. Wait, J.R., Electromagnetic Waves in Stratified Media, Pergamon; 1970.
24. Wait, J.R., Note on the Theory of Transmission of Electromagnetic Waves in a Coal Seam, Radio Science, Vol 11, Number 4, pp. 263-265; April 1976.
25. Wait, J.R., Analytical Investigations of Electromagnetic Propagation in the Earth's Crust, in the Structure and Physical Properties of the Earth's Crust, Geophys. Manor. Ser. Vol 14, edited by Meacock, p. 315, American Geophysical Union, Washington, D.C.; 1971
26. Emsile, A.G. and Lagace, R.L., "Propagation of Low and Medium Frequency Radio Waves in a Coal Seam", Radio Science, Vol. 11, No. 4, pp. 253-261, April 1976.
27. Cory, T.S., Summary Data Report No. 2 - Mine Wireless Propagation Test Program - Ireland Mine Test Data at Medium Frequency, prepared by Spectra Associates, Inc., Box 2044, Cedar Rapids, Iowa.
28. Smith, A., Coupling of External Electromagnetic Fields to Transmission Line, John Wiley and Son, New York; 1977.
29. Dobroski, H., and Stolarczyk, L.G., "A Whole-Mine Medium Frequency Radio Communication System, Sixth WVU Conference on Coal Mine Electrotechnology; August 1982.

30. Cawley, J.C., "An Assessment of Leaky Feeder Radio Systems in Underground Mines", Fifth WVU Conference on Coal Mine Electrotechnology; July 1980.
31. Welsby, V.G., Theory and Design of Inductance Coils, Wiley, London; 1960.
32. Wait, J.R., Electromagnetic Probing in Geophysics, The Golpm Press, Boulder, Colorado; 1971.
33. Deryck, L., Bulletin Technique "Mines et Carrier:", No. 134, Institute National des Industries Extractives, Belgium; 1971.
34. Delogne, P., Proceedings of Thru-The-Earth Electromagnetic Work Shop, edited by R.G. Goyer (unpublished).
35. Moser, J.R., and Spencer, R.F., "Predicting The Magnetic Fields From a Twisted-Pair Cable", IEEE Trans. Eng., EMC-10, pp 324 to 329; 1968.
36. Watt, A.D., VLF Radio Engineering, Pergammon Press, Oxford; 1967.
37. Sams, H.W., Handbook of Electronic Tables and Formulas, 2nd ED, Herrington, D., and Meacham, S. Ed., Howard W. Sams and Co., Inc. Bobbs-Merrill Co., Inc. Indianapolis; 1962.
38. Private communications with Dr. Julius Hupert.

39. Giordano, T.A., Study of Microphone/Speakers-to-Miner Interface, Final Report, Contract #J0357116  
U.S. Bureau of Mines; April 1976.
40. Andvt Microphone and Audio System Study, Final Report  
Contract #N00039-77-C-0365, Naval Electronic System  
Command, Washington, D.C.; August 1978.
41. Brouns, A.J., Development of PVF<sub>2</sub> Noise Cancelling  
Microphones, Final Report, Contract #DAAB07-77-C-0162,  
CORADCOM U.S. Army Communication Research & Develop-  
ment Command, Fort Monmouth, New Jersey; January 1979.
42. Brouns, A.J., Design and Development of a Second-Order  
Gradient Noise Cancelling Microphone, Proposal  
NOR-93100/9P-US, Dept of the Navy, Naval Electronic  
Systems Command, Washington, D.C.; September 1979.
43. Stolarczyk, L.G., etal, "Filter Synthesis Using Legendre  
Polynomials", Proc. IEEE, 114 (8) pp. 1063-1065;1967.
44. Stolarczyk, L.G., and etal, "Phase Characteristics of  
Filters Using The Legendre-Polynomial Approximation",  
Proc. IEE, 1967, 114 pp. 1427-1428; 1968.
45. Stolarczyk, L.G., "The Selection of Transfer Functions  
For Minimum Dissipation Loss" presented at the 21st  
Electronics Component Conference, Washington, D.C.,;  
May 1971.

46. Dobroski, H., and Stolarczyk, L.G., "Medium Frequency  
Radio Communication System for Mine Rescue",  
Postdisaster Survival and Rescue Research, U.S.  
Bureau of Mines, Publication IC 8907; 1982.