

FACTORS AFFECTING THE LOCATION OF METHANOMETERS ON MINING EQUIPMENT

C.D. Taylor
NIOSH, Pittsburgh Research Lab
Pittsburgh, PA, USA

E.D. Thimons
J.A. Zimmer
NIOSH/Pittsburgh Research Lab
Pittsburgh, PA USA

ABSTRACT

The U.S. Code of Federal Regulations (Title 30) requires that a methane monitor be placed on every mining machine to continuously observe and record methane levels at the face. The monitor must provide a warning whenever methane levels are 1.0 percent or higher. An effective monitoring system will indicate a methane concentration of 1.0 percent on the mining machine before methane levels at the mining face reach 5.0 percent. Where the methane monitor is located on the mining machine is one of the most important factors that determines how effectively face methane levels can be predicted. Any change in the sampling location will result in a change in measured methane concentration. To protect the methanometer, it is usually located on the cutting boom at least 1 to 1.8 m (3 to 6 ft) outby the front cutting bits.

A face ventilation system using blowing tubing was simulated in a full-scale test facility. Methane released from the face area was monitored at multiple locations on a model mining machine as well as locations near the face. Based on the relationship between concentrations measured on the machine and at the face, criteria were developed for selecting the best machine locations for monitoring methane. Recommendations are given for revising methane action levels for alternative sampling locations.

KEYWORDS

Methane sampling, underground coal mining, monitoring, ventilation

BACKGROUND

Federal regulations require that, during mining, methane levels must be continuously monitored near the mining face. The law requires that methane levels at this sampling location be maintained below 1.0 pct. Ignitions can occur at the face when methane concentrations exceed 5.0 pct. Since it is not possible to measure concentrations at the face, safety depends on the machine-mounted monitor reading 1.0 pct before the concentration at the face reaches 5.0 pct. Past experience has shown that when methane concentrations on the mining machine are kept below 1.0 pct it is unlikely that any ignition will occur near the face.

The location where the methanometer is placed on the mining machine is one of the most important factors determining how effectively methane monitoring provides safety for the workers. Federal Regulations require only that „...the sensing device must be installed as close to the working face as practical (30 CFR § 75.342).” The mining company, with the approval of MSHA, usually specifies the location for mounting the methanometer on the mining machine. The sensor head

for the methane monitor is normally placed 1.8 to 2.4 m (6 to 8 ft) from the face. Placing the instrument closer to the face can subject it to physical damage.

Research has been conducted at the National Institute for Occupational Safety and Health's (NIOSH) Pittsburgh Research Laboratory (PRL) to develop more effective techniques for monitoring methane levels at the mining face (Taylor, 1997). Special emphasis has been placed on methane sampling strategies used during extended cut mining. The objective of the current study is to develop guidelines for selecting methane-sampling locations on the mining machine. At these locations the methane measurements will provide good predictions of the highest methane concentrations at the face. A technique is given for revising methane action levels (maximum allowable concentration) when alternative sampling locations are chosen.

TEST FACILITY AND MINING MACHINE

The NIOSH Methane Test Gallery at PRL is an „L” shaped building (Figure 1). One side was designed to

model an underground mining face entry with dimensions, 4.3 m (14 ft) wide by 2.1 m (7 ft) high by 37 m (120 ft) long.

For these tests, an exhaust fan drew approximately 5.9 m³/sec (12,500 cfm) of air into the gallery. The return air was directed behind a brattice-covered wood wall constructed along the right side of the entry to the outside. Two auxiliary fans, operating in parallel, provided an airflow of either 1.9 or 3.3 m³/s (4,000 or 7,000 cfm) through 0.5 m (18 in.) diameter blowing tubing. The tubing was extended to either 0.6 or 3 m (2 or 10 ft) from the rear of the mining machine. A 3.7 m by 2.3 m (12 ft by 7.5 ft) box was placed behind the miner to represent the inby section of a continuous haulage system. The inby end of the blowing tubing, which was supported by the simulated haulage system, was approximately 1.5 m (5 ft) from the left wall and 1 m (3 ft) from the floor.

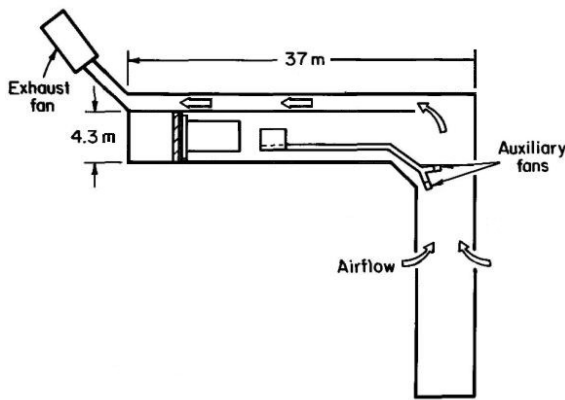

Figure 1. Methane test gallery

A full-scale-model mining machine was located at the center of the mining entry. The machine was equipped with a 4.3 m (14 ft) wide drum that was positioned 1 m (3 ft) from the floor, a water spray system, and a simulated dust scrubber. The water spray system consisted of 11 hollow-cone (BD-3) sprays, which were mounted on top of the boom and directed straight toward the face. With the sprays operating, the pressure was 965 kPa (140 psi) with a flow of 53 l/min (14 gpm). The water sprays were operated only when the scrubber was on.

The scrubber system (Figure 2) consisted of:

- inlets on each side of the mining machine approximately 2.7 m (9 ft) from the bit tips,
- two fans with attached ducts to move the air from the inlets to the exhaust, and
- an exhaust opening at the right rear of the machine chassis.

Tests were conducted with the scrubber off or flows of either 1.9 or 3.3 m³/s (4,000 or 7,000 cfm).

METHANE RELEASE AND INSTRUMENTATION

During the continuous mining of coal, most methane liberated in the face area comes from either the newly exposed face, or pieces of broken coal as they are crushed by the rotating miner head. To model face emissions, methane was released through four, 3.7 m (12 ft) long copper pipes that were equally spaced horizontally, and located 0.1 m (4 in.) away from the face. Holes 2 mm (1/16 in.) in diameter, were drilled 5 cm (2 in.) apart on top and bottom of each pipe to provide a relatively uniform discharge of gas. The gas flow rate for each test was 3.3 l/sec (7 cfm).

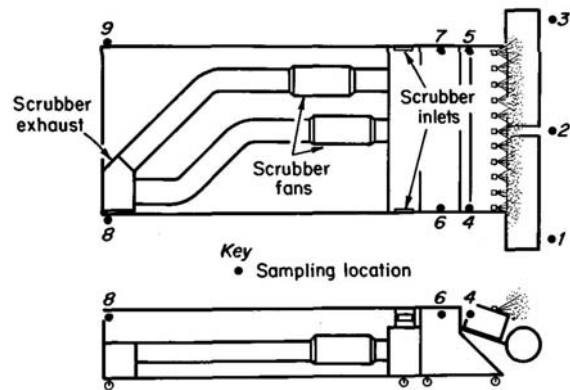

Figure 2. Scrubber system and machine methane sampling locations

METHANE SAMPLING LOCATIONS

Methane gas concentrations were monitored concurrently at nine locations using catalytic heat of combustion methanometers. The locations were grouped into „face” and „machine” areas as shown in Figure 2, and described below.

Face areas:

- #1 - 0.3 m (1 ft) from roof and manifold and 0.5 m (1.5 ft) from right wall,
- #2 - 0.3 m from roof and manifold at the center of entry, and
- #3 - 0.3 m from roof and manifold and 0.5 m from left wall.

Machine areas:

- #4 - Right side of machine, 1.5 m (5 ft) from face,
- #5 - Left side of machine, 1.5 m from face,
- #6 - Right side of machine, 2 m (6.5 ft) from face,
- #7 - Left side of machine, 2 m from face,
- #8 - Right rear of machine, 7.9 m (26 ft) from face,
- #9 - Left rear of machine, 7.9 m from face.

Table 1. Test Operating Conditions

| Test Condition | Blowing Tubing Distance from Rear of Machine, (m) | Intake Air Flow Quantity, (m ³ /s) | Scrubber Flow, (m ³ /s) | Sprays, On/Off |
|----------------|---|---|------------------------------------|----------------|
| 1 | 0.6 | 1.9 | Off | Off |
| 2 | 3.0 | 1.9 | Off | Off |
| 3 | 0.6 | 3.3 | Off | Off |
| 4 | 3.0 | 3.3 | Off | Off |
| 5 | 0.6 | 1.9 | 1.9 | On |
| 6 | 3.0 | 1.9 | 1.9 | On |
| 7 | 0.6 | 3.3 | 3.3 | On |
| 8 | 3.0 | 3.3 | 3.3 | On |

Table 2. Results for „Best Straight Lines”

| Highest Face Concentration | | | | | |
|----------------------------|-------------------------------|-------------------------|--------------------------------------|--------------------|---------|
| Face Loc. | Y-Intercept (b ₀) | Slope (b ₁) | T-test 95% confidence (significance) | R ² (%) | P-Value |
| 4 | 0.33 | 1.12 | Yes | 61.5 | 0 |
| 5 | 0.82 | -0.01 | No | 0 | 0.98 |
| 6 | 0.17 | 1.34 | Yes | 65.4 | 0 |
| 7 | 0.81 | -0.002 | No | 0 | 0.99 |
| 8 | 0.12 | 3.47 | Yes | 72.6 | 0 |
| 9 | 0.87 | -0.92 | No | 0.91 | 0.72 |

OPERATING CONDITIONS

Blowing tubing location, intake air flow, scrubber flow, and spray operation were varied to simulate different operating conditions that could be encountered during mining. The variables for each test are given in Table 1.

DATA COLLECTION

Prior to the start of each test the desired operating conditions were set. Next, methane gas was introduced into the gallery for 5 min to allow the gas and air to mix. After the mixture reached a relatively steady state concentration, data was collected at each location for 5 minutes.

Data from each methanometer was downloaded every two seconds to a personal computer via an analog to digital conversion board. For each of the locations sampled, the average methane concentration for each five minute sampling period was calculated using an electronic spreadsheet file.

RESULTS

The highest of the three concentrations measured at the face was compared to each of the six concentrations measured at the sampling locations on the machine. Scatter diagrams, (Figure 3) drawn for each of these

locations, include data for all 8 test conditions. Each test was repeated one time. The „best straight line” was drawn through each of the scatter diagrams using the method of least squares. Estimators of each line’s slope (b₁) and y-intercept (b₀) are given in Table 2.

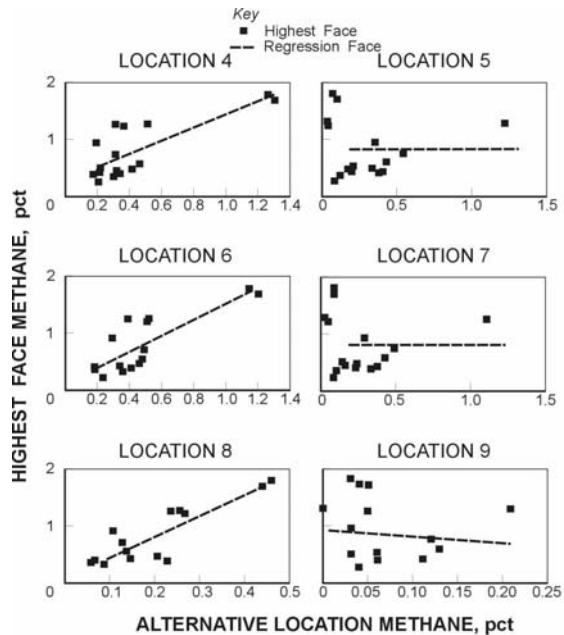

Figure 3. Comparison of highest face methane concentrations and concentration on mining machine

The student t distribution was used to determine, for each straight line, if there is a statistically significant difference (95% confidence) between the slope of the line and zero. Relationships between the variables (concentration on the machine and at the face) are significant only if the slope is significantly greater than zero. „P values” are also given in Table 2 for each straight line. A „P value” less than 0.05 indicates there is a statistically significant relationship between the highest concentrations at the face and sampling locations on the machine at the 95% confidence level.

Based on the T-test, there is a significant relationship between the highest face concentration and the concentrations measured at locations 4, 6, and 8. The relationships between the highest face concentration and machine locations 5, 7, and 9 were not significant. P-values were less than 0.05 for locations 4, 6, and 8 and greater than 0.05 for locations 5, 7, and 9.

Airflow patterns drawn with the aid of smoke tubes were also used to evaluate the location of methanometers on the mining machine. Figure 4 illustrates a typical airflow pattern drawn for the ventilation systems tested. In general, air from the tubing moved up the left side of the entry, across the face, where the methane was released, and back the right side of the entry to the return. Based on these flow patterns it would be expected that:

- Methane concentrations would be higher at the sampling locations closer to the face where the methane was released.

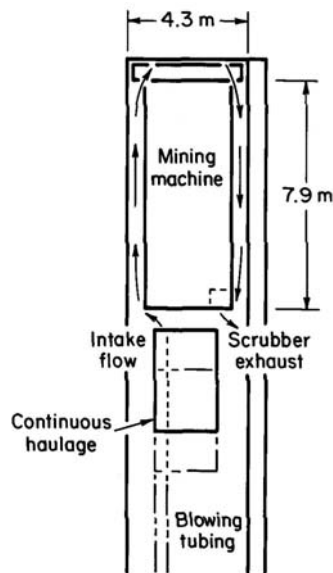

Figure 4. Face airflow patterns

- Methane concentrations would be higher at sampling locations on the right side of the face where the air passes as it moves toward the return. In addition, because the air from the face passes directly over the right side, but not the left side sampling locations, it is more likely

there would be some direct relationship between the concentrations at the face and locations 4, 6, and 8.

These expectations were confirmed by the sampling results.

DISCUSSION AND CONCLUSIONS

Prevention of face ignitions depends on maintaining face methane levels below 5 pct. The peak or highest methane concentration measured at the face is the best indicator of the potential for a face ignition. During normal mining it is not possible to measure methane concentrations at the face, but, for these tests conducted in a simulated mine environment, methane concentrations were measured at the face. The highest of the three face concentrations was used to represent the peak face concentration. Concentrations measured on the mining machine were compared to the highest methane concentrations measured at the face.

To compare concentrations on the machine to the highest face concentration, the „best straight line” was drawn through each of the plots. The straight-line model is the simplest one for comparing the data and there was no reason to believe a more complex model would fit the data better. The t-test, used to evaluate the slope of each straight line, showed that there was a statistically significant relationship between machine and highest face concentrations for locations 4, 6 and 8. The t-test alone should not be used as the only criteria to determine if a location should or should not be used as a machine sampling location. For example, when selecting a sampling location, the law requires that the sampling location be as close to the face as practical. Although, based on the t-test, location 8 is a possible sampling location; it is unlikely that it would be selected because it is so far 7.9 m (26 ft) from the face.

When comparing concentrations measured on the machine and at the face, the scatter of the data points around the best straight lines should also be considered. Based on the R^2 values, which are a measure of the clustering of the data around the best straight line (see Table 2), there is similar scatter of the data for each of the possible sampling locations on the right side of the face. Part of the variation was due to changes in operating conditions between tests. Further studies are needed to determine the effects of these factors on sampling precision.

The study results show that location 4 is one possible sampling location for the machine-mounted methanometer, although placing it that close to the face (approximately 1.5 m) could result in physical damage. Using the best straight line model for data collected at the face and location 4 (Figure 5), it is possible to predict the highest face concentrations corresponding to concentrations measured at location 4. For example, if the concentration at location 4 is 1.0 pct, the highest predicted face concentration would be approximately 1.5 pct. The dashed lines in Figure 5 are the prediction limits (95% confidence) for the best straight line. Using the prediction limits it can be seen that 95 pct of the time the highest face methane concentration will not exceed 2.3 pct as long as the concentration at location 4

does not exceed 1 pct. As long as methane levels at location 4 do not exceed 1 pct, methane levels at the face will remain below 5 pct.

Although the level of safety provided by sampling at a specific machine location is never known exactly, changing the sampling location will usually affect the level of safety. Before moving the sampling location it should be shown that the level of safety would not be reduced by moving the methanometer.

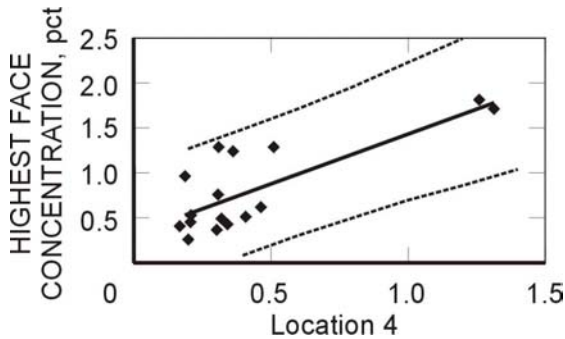

Figure 5. Comparison of highest face and location 4 concentrations with prediction limits

Maintaining the same level of safety may require that the action level (maximum allowable concentration) be reduced for the new sampling location. One technique for determining the action level for a new sampling location can be illustrated by using methane measurements made at locations 4, 6, and 8.

Let location 4 be the designated machine sampling location, and locations 6 and 8 the possible alternative sampling locations on the mining machine. The methane concentration at location 4 can not exceed 1 pct. In order to maintain an equivalent level of safety for the worker, what should be the maximum allowable methane concentrations if methanometers are located at either locations 6 and 8.

The scatter plots in Figure 6 compare concentrations measured at location 4 with concentrations at locations 6 and 8 for the test conditions described earlier. The best straight line, drawn for each plot, is used to predict what the concentration at locations 6 and 8 would be when the concentration at location 4 is 1.0 pct. When the concentration at location 4 is 1.0 pct, the predicted concentrations at locations 6 and 8 are 0.96 and 0.38 pct respectively. If the sampling location was moved to either location 6 or 8, the maximum allowable concentrations would have to be reduced to these levels to maintain the equivalent level of safety.

Equivalent safety is provided to the worker as long as the highest face concentration does not increase. During these tests the highest face concentration was measured and the parameters for the best straight lines were calculated (Table 2). The equations for relating the highest face concentration (y) to the concentration measured on the machine (x) are:

$$\text{Location 4: } y = 1.12(x) + 0.33$$

$$\text{When } x = 1.0 \text{ pct, } y = 1.5 \text{ pct}$$

$$\text{Location 6: } y = 1.34(x) + 0.17$$

$$\text{When } x = 0.96 \text{ pct, } y = 1.5 \text{ pct}$$

$$\text{Location 8: } y = 3.47(x) + 0.12$$

$$\text{When } x = 0.38 \text{ pct, } y = 1.5 \text{ pct}$$

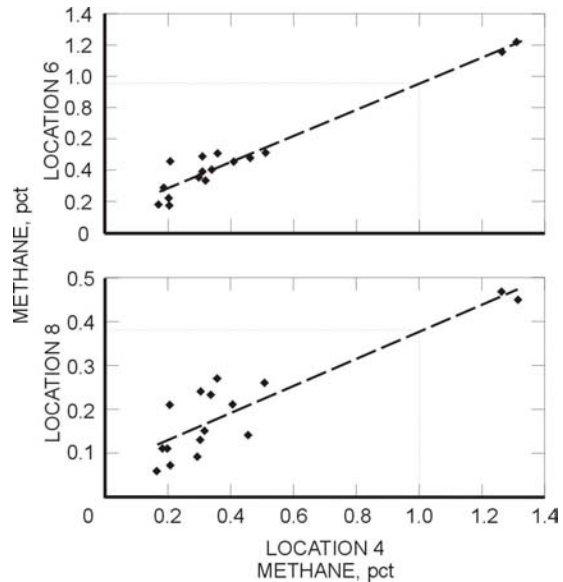

Figure 6. Comparing methane concentrations at location 4 with concentrations at locations 6 and 8

Substituting the maximum allowable methane concentration of 1.0 pct for location 4, 0.96 for location 6 and 0.38 for location 8, the predicted highest face concentration is the same (1.5 pct). Again this demonstrates how the action level for methane concentrations can be revised for new sampling locations in order to provide an equivalent level of safety.

It is the methane reading taken at the designated location on the mining machine (and not the face concentration) that determines compliance with the 1 pct standard and it is the reading at this location that establishes the level of protection provided to the worker. Alternative locations should be used only if it can be demonstrated that these locations provide equivalent protection for the workers. This study provides guidelines for selecting sampling locations on the mining machine obtained during tests that simulated a range of operating conditions typical of one type of extended cut mining. The guidelines will vary depending on the type of mining operation.

REFERENCES

- Taylor C.D., and Goodman G.V.R., 1997, „Use of Methane Monitors for Estimating Face Gas Conditions," Applied Occupational & Environment Hygiene (AOEA), 12(12), December, pp. 947-951