

# Case Studies of Cable Bolts Using Instrumented King Wires

Lewis A. Martin

*Spokane Research Laboratory, National Institute for Occupational Safety and Health, Spokane, WA*

R. Pakalnis

*University of British Columbia, Vancouver, BC*

Richard P. Curtin

*Spokane Research Laboratory, National Institute for Occupational Safety and Health, Spokane, WA*

## ABSTRACT

Instrumented cable bolts developed at the Spokane Research Laboratory of the National Institute for Occupational Safety and Health were used in conjunction with existing ground control to monitor rock mass loads at various field sites (FMC Granger, Getchell, Meikle, SSX, K-2, and Stillwater). Axial and shear loads were determined by strain gauges to levels of instrument accuracy of  $\pm 5$  N or  $\pm 5$  microstrain as these loads were transferred to the instrumented cable bolts. These gauges were 12.5 mm long and embedded into a remanufactured king wire that replaced the conventional king wire. Cable bolt performance, quality of grout, and installation techniques were also assessed. By using instrumented cables, a mine operator can determine axial load along the cable at predefined gauge locations. By monitoring load on and displacement of the rock mass, more effective ground support can be selected and installed, which will lead to safer working conditions for miners.

## BACKGROUND

Until recently, external measurement devices such as the tensmeg or resistance wire cable strain cell gauges (Hyett et al. 1997) were used to determine load on cable bolts. In 1996, the “stretch measurement to assess reinforcement tension” (SM.A.R.T) cable was developed and patented by researchers at Queens University (Hyett et al. 1997). This system replaces the king wire of a cable bolt with multipoint extensometers (MPBX's) enclosed in a tube to measure cable elongation, thereby enabling deformation and load to be determined (Bawden et al. 1998).

Researchers have previously expressed the view that an internal gauge would be too expensive to use with cables as an instrument within mines. Another issue is that external gauges on cables may fail because of water seepage through the grout before the cable begins to take on load (Goris et al. 1993). The usefulness of a ground control instrument having gauges mounted in the center of the cable or on the king wire was shown by Signer (1990) in research on the use of resin-grouted rebar bolts in coal mines.

Rock mass, grout quality, effective anchorage length,

and cable load can now be determined with cement- and epoxy-grouted cables. In 1998, researchers at the Spokane Research Laboratory (SRL) of the National Institute for Occupational Safety and Health (NIOSH) developed an “Instrumented King Wire Cable Bolt” (patent 60/076,138). This instrument uses a different approach during the manufacturing process in which the king wire is molded from epoxy around a flat piece of steel containing strain gauges.

## CONCEPT

The instrumented king wire cable bolt has 12.5-mm-long strain gauges embedded in the king wire at positions defined by the mine operator. Presently, 10 gauges can be installed along a resin-grouted bolt up to 5 m long or a cement-grouted bolt up to 7 m long. These constraints are largely due to current manufacturing processes and not to limits on the system. The gauges can either be set in pairs to detect shear load in the same plane or the flat stock can be set at 90° angles to detect loads in three directions. The cables are capable of sustaining an ultimate load of 251 kN and can produce reliable readings to 179 kN, as shown by the calibration curve in figure 1.

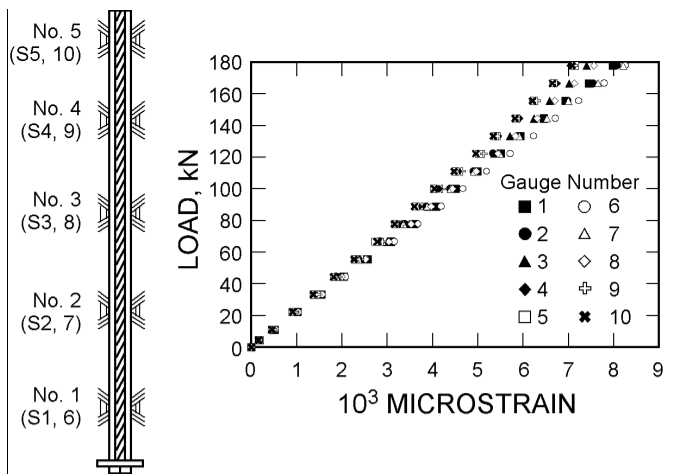

Figure 1.—Calibrated curve for instrumented king wire cable bolt.

To create an instrumented king wire cable bolt, strain gauges are first installed on both sides of an 8- by 2.4-mm metal strip at various user-specified positions on the bolt (figure 2). The individual strain gauges are connected to an instrument plug by 30-awg wire. This apparatus is then placed in a steel mold and injected the total specified length of the bolt with a two-part epoxy. This new king wire measures 8.3 mm in diameter.

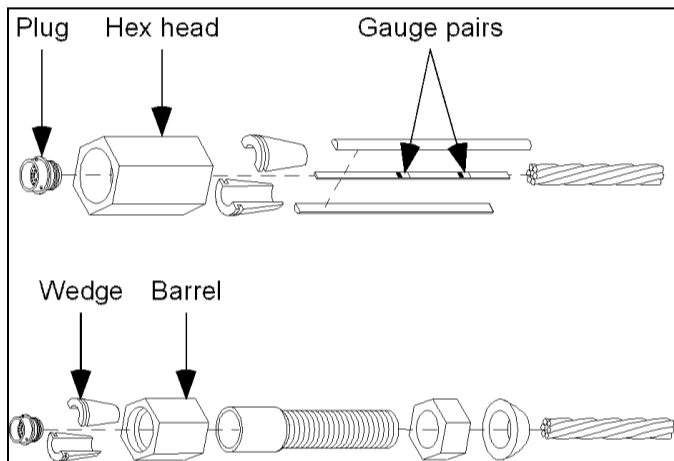

Figure 2.—Instrumented cable bolt assembly with and without pretension head.

The original cable is uncoiled strand by strand, the original center wire is replaced by the new epoxy-filled king wire, and the outer six strands are rewound around it, resulting in an instrumented cable bolt. The gauge wires protruding from the center are then inserted into a 12-pin connector. This connector is recessed into a 4.4-cm hex head attached to the cable by means of a barrel-and-wedge assembly (figure 2).

The cables are fitted with special heads so they can be inserted by either a jackleg drill or a roof bolter. An

instrumentation plug is used to monitor the gauges. A data acquisition system is required to read the loads.

The system has been tested on a Vishay strain indicator box, a Campbell Scientific system, and an Omni Data system.

## MATERIAL DESCRIPTION

Standard cable specifications were the American Society of Testing Materials (ASTM) standard A416, 0.6-in, grade 270 K, low-relaxation, seven-strand cable having a minimum breaking load of 258 kN with 3.5% elongation. Upon removing the original king wire and replacing it with the manufactured one, minimum breaking load was reduced to 214 kN with reliable strain readings to 179 kN. Calibration tests at SRL provided correlation of microstrain to load to enter into the data collection system (figure 1). This technique was used successfully throughout the elastic load-strain range on instrumented rebar bolts by Signer et al. (1997).

## CABLE DESIGN

Laboratory tests were conducted on instrumented king wire cable bolts embedded in concrete blocks to obtain calibration curves for converting microstrain to load in kilonewtons. Pull tests were also conducted to determine the load-carrying characteristics of the bolts. The strain gauges were mounted 0.15, 0.35, 0.61, 0.91 and 1.22 m from the head of the bolt (figure 1). The cables were loaded to 179 kN using hydraulic pull test equipment. A strain-to-load curve is shown in figure 3 and is typical of what Goris et al. (1994) observed in pull tests with conventional cable bolts.

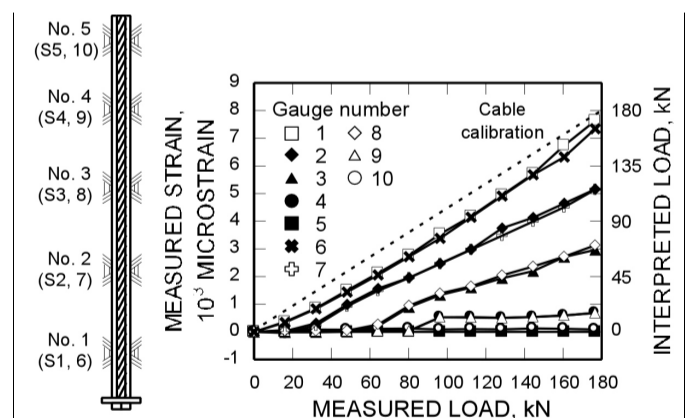

Figure 3.—Calculated load and strain on grouted cable bolt with instrumented king wire.

These tests aid in explaining how load on cable bolts is transferred from the cable to the grout and then into the rock mass. A “shelling” effect is shown whereby the grout-cable interface breaks down and the gauge becomes unbonded as load is increased and is taken fully by the cable. Figure 3 shows results of the pull tests as a load profile along the cable length. The curve shows that a 128-kN (~12.8-tonne) pull load on the collar of the cable resulted in measured strain loads of 123 kN along gauges 1 and 6 at a distance of 0.15 m from the collar. Researchers interpreted this measurement (5 kN) as the amount of load the cable was not sensing 0.15 m from the collar. At 1.22 m from the collar, the cable did not sense any load, which indicates critical bond length. Other researchers (e.g., Goris et al. 1994). have reported critical bond length to be approximately 1 m for standard cable. This load capability enables an operator to measure failure in real time as debonding of the grout-cable interface is initiated. In addition, the difference between cable load and applied load indicates grout quality, which can be a better field test of the quality of cable bolt installations than field pull tests.

## CASE STUDIES

Cable bolts with instrumented king wires were tested at six mines. The results of these tests are described below. For simplification, the terms “cable bolts” will mean bolts in which the conventional king wire has been replaced with the new remanufactured king wire.

### Case Study 1: Trona (FMC Granger)

Cable bolts were installed in the roof of FMC Granger’s trona mine, a room-and-pillar operation in Wyoming, to measure roof loads in the intersection of 350S and 12371E (figures 4 and 5). This location was chosen because of drill access ahead of the mining cycle and because loads would be induced in the cable bolts as ore was extracted toward the intersection. Mine personnel were interested in determining the potential for instability in the back and the extent of any unwedged blocks.

Ground support was installed after development and during rehabilitation. Strain gauges were positioned along rebar and cable bolts at depths that would ensure that loads in the resin grout would be measured. In addition, a set of gauges was mounted at an ungrouted section to measure dead weight loads

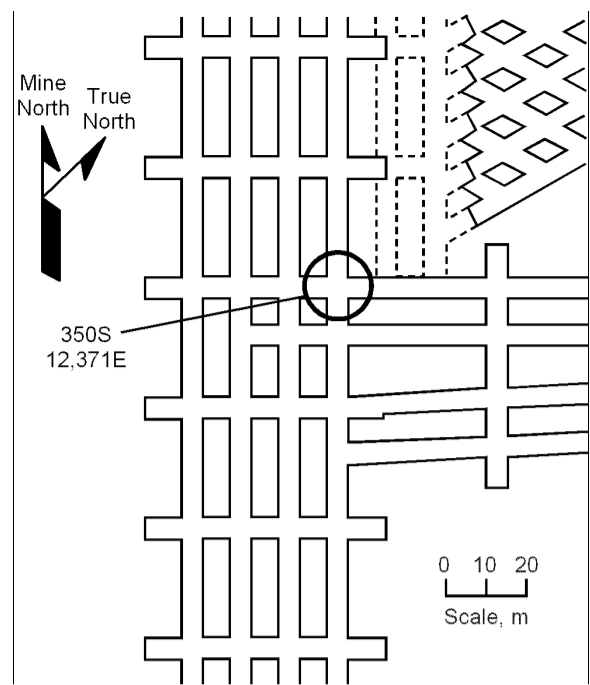

Figure 4.—Instrument locations in trona mine.

in the rock mass. Figure 6 shows the position of the strain gauges with respect to the collar. The longest cable bolts were installed at the center of the intersection because these bolts would receive the greatest loads, while shorter cable bolts were installed north of the intersection closer to the pillar front. Resin-grouted rebar bolts were placed in the south part of the intersection to measure loads where the density of rebar bolts was highest. Sagmeter stations were set at

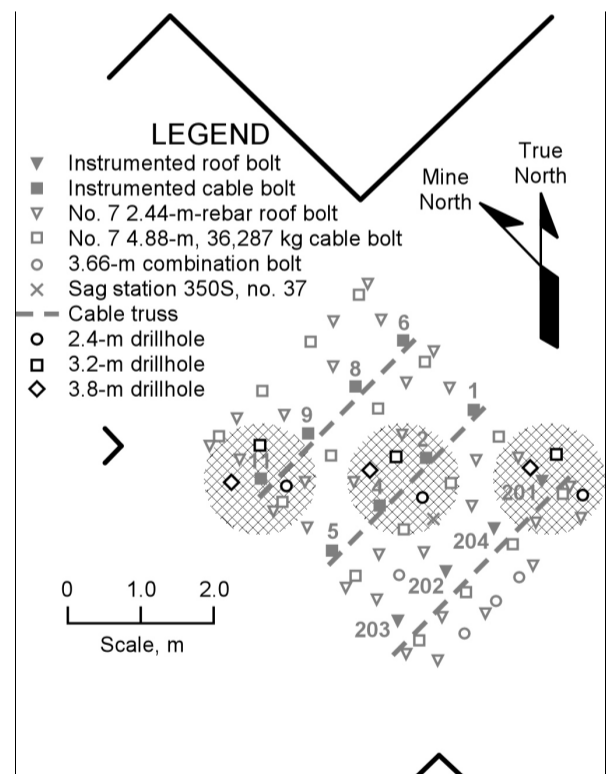

Figure 5.—Bolt and sagmeter locations.

three locations in the intersection (figure 5), and holes were drilled to depths of 2.4, 3.2 and 3.8 m. These sagmeter depths were chosen to correspond with the bolt gauge profiles (figure 6), allowing correlations to be made between deformation recorded by the strain gauges to deformation recorded by the sagmeter stations. This is important because slip expected to occur between the cable-grout-rock interface can be compared to actual rock deformation.

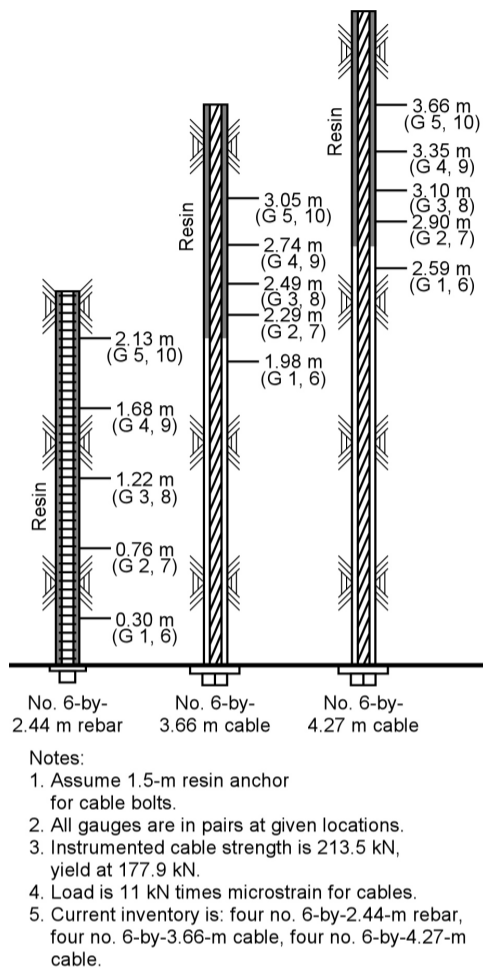

Figure 6.—Positions of strain gauges on bolts (note two at each position).

### Results of Measurements on Instrumented King Wire Cable Bolts

Loads on the cable bolts were measured from April 29 through July 11, 1999. Mining activities influencing the intersection were progressing from northeast of the site to the south (figure 4). On June 9, mining reached a point one pillar width from the intersection (8 m). Figure 7 shows all load profiles measured by the 4.27-m-long bolts (bolts 1, 2, 4, and 5) and the 3.66-m-long bolts (bolts 6, 8, 9, and 11). Approximately the last 1.5 m of the bolt was bonded with resin grout. What follows is the authors' interpretation of loads on

eight bolts. By recording actual point loads in the cable, it will be possible to understand more readily the likelihood that instabilities may be forming or that there may be problems with the quality of the installation.

- Gauges 2 and 7 on bolt 1 were indicating loads up to the yield limit of the steel. These loads were higher than the axial dead weight loads on the ungrouted section of the bolt and loads on the grouted gauges, indicating that some delamination was occurring close to the gauge. The higher readings were most likely a result of the fact that concentrated load is measured over the gauge length by a strain gauge, whereas an ungrouted gauge measures the sum of all delamination cracks over the length of the ungrouted section, which was 2.8 m. The result is an average load much lower than that of a bonded cable over a given distance.

- Bolt 2 was inspected by mine personnel, who determined the bolt had broken.

- Bolt 4 shows a load shelling profile similar to that shown in the laboratory (see figure 3). The greatest load was recorded 3.1 m above the back by gauges 3 and 8. The ungrouted length (2.8 m) shows a low load primarily because load was distributed over a large distance, as discussed previously. It must be noted that loads were lower on the gauges on either side of the bolt at 3.1 m, implying that a crack was close by.

- Bolt 5 shows the classic load shelling profile. The highest load was recorded in the ungrouted section within 2.8 m of the back. The next highest load was at the bonded gauge 2.9 m from the back. Readings again indicate that delamination was largely controlled by cracks within 3 m of the back.

- Loads on bolt 6 were uniform, with an average of 40 kN, excepting for gauges 2 and 10, which were located 2.3 m above the back. This implies that delamination may have been occurring at this location. Note that this bolt was close to the pillar boundary and therefore the depth of cracking would be less.

- Gauge sets 2 and 7 (2.3 m deep), 3 and 8 (2.5 m deep), and 4 and 9 (2.7 m deep) on bolts 8 and 9 showed a load profile approaching, and in most cases reaching, the yield strength of the bolt. This reading indicates that delamination was occurring throughout the horizon or that rock mass loading was higher. These two bolts were placed in the north-center section of the site, which experienced high loads such

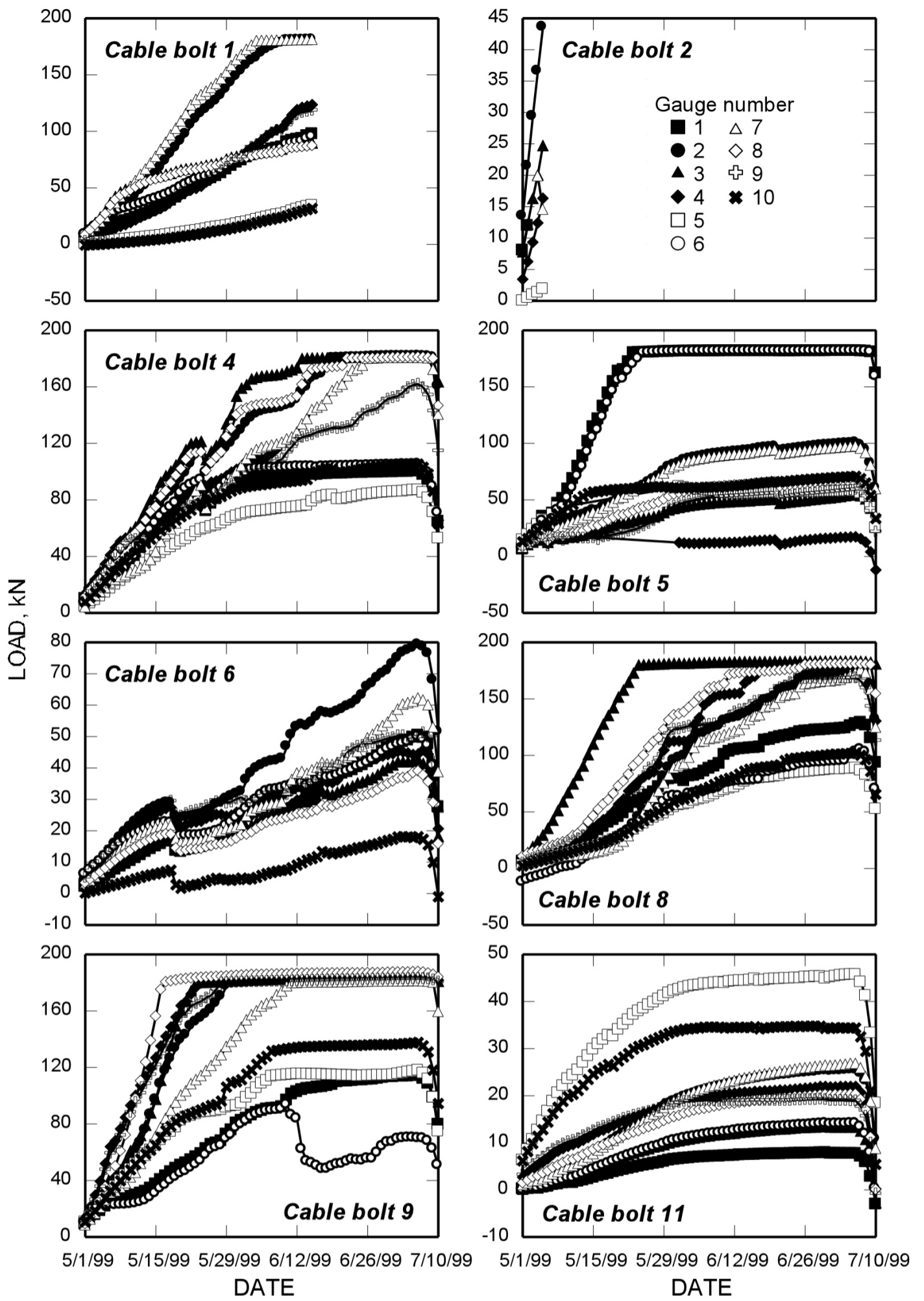

Figure 7.—Load profile versus time on 4.27-m-long bolts (1, 2, 4, and 5) and 3.66-m-long bolts (6, 8, 9, and 11).

as those on bolt 4, which had also been placed in the center of the intersection. The deepest gauges (5 and 10) at 3.1 m in the back recorded low values, indicating that the bond at depths between 2.7 and 3.1 m was sufficient to absorb most of the load.

- Bolt 11 was located at a pillar boundary and therefore was receiving more support from the mine rock, resulting in less delamination. Therefore, loads were lower. Representative load curves for the 3.1-m-deep gauge resulted in the greatest amount of load. The second set of gauges, at 2.3 m deep, showed the next highest load, and the first set of gauges, at 2.59 m deep, had the lowest loads. Delamination was, however, occurring, albeit at low loads, approximately 3 m above the back.

#### Results of Measurements at Sagmeter Stations

Three sagmeter stations were installed at three different depths (2.4, 3.2, and 3.8 m) at the intersection of 350S and 12,371E (figure 5). Figure 8 shows that sagmeters at the three stations generated similar curves with displacements ranging from 0.5 to 2.0 cm. In general, the most centrally located station had the greatest displacements at all three depths. Generally, the north-northwest and south-southwest

sagmeter stations, which were near the boundary pillars, showed the least amount of deformation. Delamination was observed throughout all horizons with the largest amount of movement between 2.4 and 3.8 m of the back. This roof movement corresponded with data collected from the strain gauges, showing that delamination was generally 3 m above the back. Sagmeter readings from the 3.2-m-deep hole at the center of the intersection would be comparable to readings from a 4.3-m-long cable bolt with 1.5 m of resin embedment. This would mean 2.8 m of unbonded cable length.

Hook's law as applied to a cable with a steel modulus (E) equaling  $2.3 \times 10^{11}$  N/m<sup>2</sup> and a cable area of 0.00011 m<sup>2</sup> would yield an elongation of 2 cm over 2.8 m. The calculated force would be approximately about 180 kN. This force correlates with data from the cable bolt for the unbonded section of bolt 5, gauges 1 and 6 (figure 7), and bolt 4, gauges 2 and 7. Based on this information, it is likely that the resin bond was destroyed as a result of loading.

The above case history is being further evaluated with respect to deformation, mining sequence, and behavior of the back. The depth of failure most likely is 3 m.

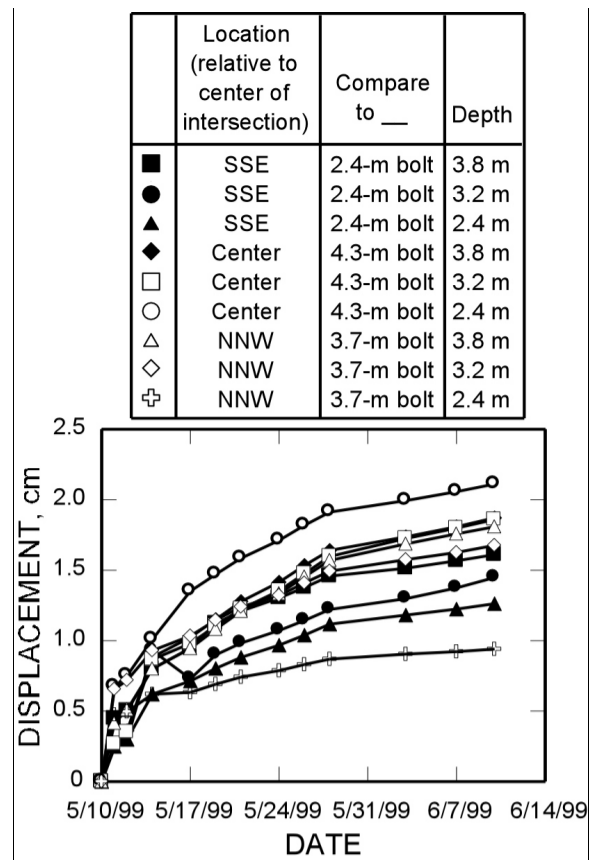

Figure 8.—Displacement of back over time.

Employing a support pattern of bolts placed on 1.2- by 1.2-m spacings and a specific gravity of 2.6 for the sandstone back would yield a dead load of approximately 110 kN, which is within the range of loads as measured by the bolts. Readings from these cable bolts enable researchers to understand overall support-rock interaction.

#### Case Study 2: Getchell Mine, 4950 Stope Areas (Placer Dome)

Ten 3.6-m-long instrumented cable bolts were installed at the Getchell Mine, which is a transverse, open-stopping operation in Nevada. Gauges were spaced 0.6 m apart at five positions on the cable bolt. A tensionable head was placed on the bolt (figure 9), and the bolts were grouted with a cement-based grout into the back and ribs at the locations shown in figure 9. The bolts were then tensioned 10 kN on the cables and bearing plates. The instruments were placed after the primary cuts had been backfilled and the secondary drifts to the ore were about to be mined. This enabled analysis of the effects of secondary and tertiary mining effects.

Preliminary data indicate that bolt 4 in the stope is showing a load higher than 10 kN (figure 10) while

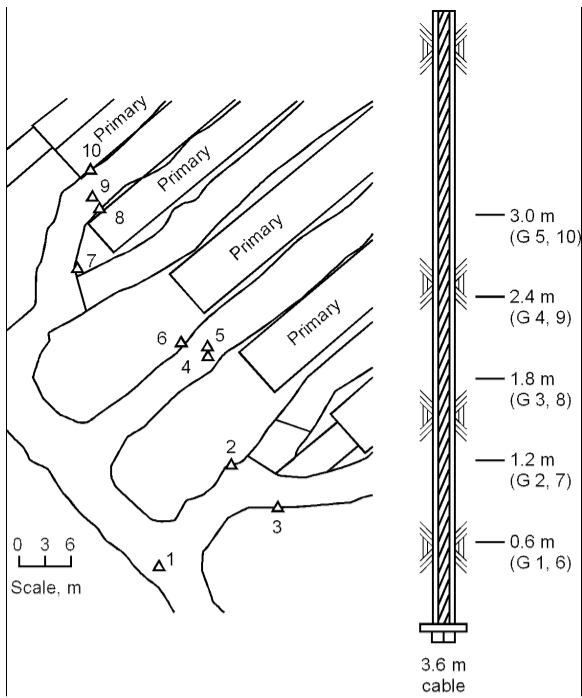

Figure 9.—Plan view of 4950 stope showing locations and depths of strain gauges.

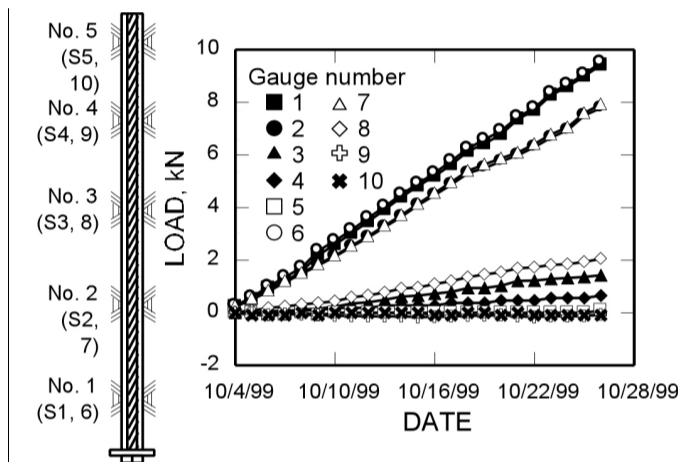

Figure 10.—Load on bolt 4 at Getchell Mine.

the rest of the bolts are not showing any significant loading (under 1 kN). Loading on bolt 4 suggests that a crack is most likely developing between gauges 1 and 6 (0.6 m deep) and gauges 2 and 7 (1.2 m deep). A borescope survey was conducted as part of this study and located a crack 0.9 m above the back. Based on a 1.2- by 1.2-m bolting pattern and a depth of 0.9 m (specific gravity = 2.6), a dead load of 38 kN is likely. Measurements and interpretations of the strain data were reinforced by subsequent visual observations intended to provide a higher level of safety for the operator. This area of the mine was reinforced.

### Case Study 3: Meikle Mine, Nevada (Barrick Goldstrike)

An instrumented king wire cable bolt was placed into the shop area at the 1250 level of the Meikle Mine. This area was selected because a dike in the roof was delaminating, and mine personnel wanted to know how much load was being transmitted to the ground support. The 6-m-long cable bolt was placed perpendicular to the crack created by the dike. Strain gauges were placed on the bolt so that when it was installed, the gauges were 1.2 and 0.61 m deep on either side of the crack and one at the crack location. Half the instrumented bolts lost the common ground wire to the strain gauges, and no readings were obtained from that side of the bolt. Loading on the 1.2- and 0.61-m-deep gauges reached 178 kN while a gauge at the dike showed minimal load. Cable strain was reaching failure, so the area was reinforced.

### Case Study 4: K-2 Mine (Echo Bay Minerals)

The K-2 Mine is a longhole open stoping operation in Washington. The purpose of the project was to determine loads in the backs of stopes and brows. One of six instrumented cable bolts to be placed at the mine have been installed and is producing data. This bolt is 3.7 m long with five sets of gauges spaced at 0.61-m intervals.

The cable bolt was placed into the mine back directly above the sublevel open stope. Preliminary data show low loads on all gauges along the bolt (figure 11). The cable is approaching yield at gauge 5 (3 m deep), and delamination appears to be occurring close to 3 m above the back. The immediate back exhibits minor loading (gauge 1 at 0.6 m deep). The area where the cable bolt is installed is inaccessible since the open stope has yet to be backfilled. There is no concern for personnel because the stope below is nonentry.

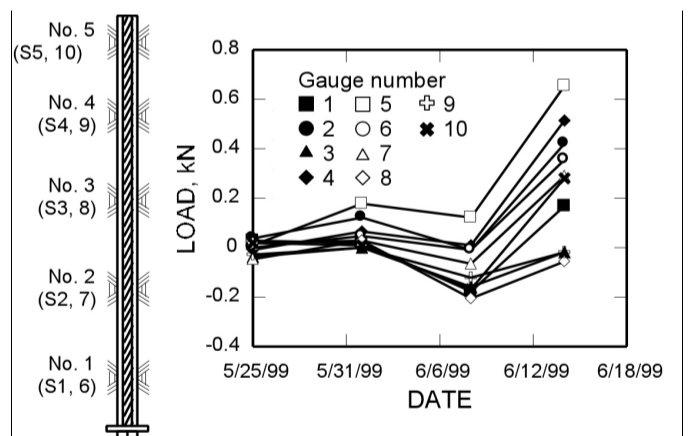

Figure 11.—Load on bolt 14 at K-2 Mine.

## Other Installations

A series of three cable bolts was installed at AngloGold's SSX Mine, NV, in a transverse stope. Two of the bolts were placed into the back above the upper stope and a third into the brow. When the stope was shot, the data cables were damaged by blast rock, and so the instruments cannot be read until backfilling operations are completed.

The Stillwater Mine, which is a sublevel open stoping operation in Montana, plans to install five 3.7-m-long cables bolts with gauges spaced at 0.61 m.

## CONCLUSIONS

In all installations where the gauges have been read, cable bolts were responsible for delivering information about loads in the immediate rock mass. Grout quality could be determined by relating bonding capacity of these cable bolts to that of the load profile of the un-grouted bolts. The cable bolt was found to be reliable in warning of instabilities and has been calibrated to deformation of the adjacent rock mass.

The dangers of assuming that deformation is linear across a bonded cable were also suggested as the load profile showed the relationship of the degree of grout bonding to load along the cable. The simple relationship of strain to load calculated with cable modulus is only valid for the ungrouted sections of cable. However, the grouted sections of the cable should be calculated using calibrated data to determine the strain relationship. The above interpretation is only possible if point strains and loads on a cable are known.

By monitoring load on and displacement of the rock mass, more effective ground support can be selected and installed, which will lead to safer working conditions for miners.

## ACKNOWLEDGMENTS

If not for the cooperation of the mining companies and their mine engineers, this research would not have been conducted. We would like to thank John McDonnell, FMC Granger; Pat McCann, Getchell Mine; Lauro Lacerda, Mickle Mine; Ken Boie, K-2 Mine; and Colin Connors, SSX Mine, for their valued assistance. We would also like to thank Steve Signer, engineer at SRL, for his expertise in the application of Campbell Scientific systems, and Dennis Cox, Richard

Rains and Joanne Johnson, engineering technicians at SRL, for their dedication in constructing the instrumented bolt systems.

## REFERENCES

Bawden, W.F., Hyett, A.J., Laush, P.M, Moosavi, M., Degraaf, P., and Ruest, M., 1998. The S.M.A.R.T. Cable Bolt: Results from Two Initial Field Trials. Presentation at 100th ann. general meeting of Can. Instit. Min. and Metall., Montreal, PQ, May 3-7, 1998, 8 pp. Available from author and on CD-ROM from CIM, Montreal, PQ.

Goris, J.M., Brady, T.M., and Martin, L., 1993. Field Evaluation of Cable Bolt Supports, Homestake Mine, Lead, SD. U.S. Bur. Mines Rep. of Invest. 9474, 29 pp.

Goris, J.M., Nickson, S.D., and Pakalnis, R., 1994. Cable Support Technology in North America. U.S. Bur. Mines Infor. Cir. 9402, 52 pp.

Hyett, A.J., Bawden, W.F., Ruest, M., and Pakkala, M., 1997. The S.M.A.R.T. Cable Bolt: an Assessment for the Determination of Tension in Seven-Wire Strand Cable Bolts. International Symposium on Rock Support: Applied Solutions for Underground Structures, ed. by E. Broch, A. Myrvang, and G. Stjern (Lillehammer, Norway, June 22-25, 1997).

Signer, S.P., 1990. Field Verification of Load Transfer Mechanics of Fully Grouted Roof Bolts. U.S. Bur. Mines Rep. of Invest. 9301, 13 pp.

Signer, S.P., Cox, D., and Johnston, J., 1997. A Method for the Selection of Rock Support Based on Bolt Loading Measurements. International Symposium on Rock Support: Applied Solutions for Underground Structures, ed. by E. Broch, A. Myrvang, and G. Stjern (Lillehammer, Norway, June 22-25, 1997).