

A.R.F. PRODUCTS, INC.

ENGINEERS AND MANUFACTURERS OF PRECISION ELECTRONIC EQUIPMENT

23 OCTOBER 1978
A COMPARISON BETWEEN
SSB AND FM MODULATION PROCESSES
IN A NEAR FIELD MEDIUM FREQUENCY
WIRELESS COMMUNICATION SYSTEM

BY

LARRY G. STOLARCZYK, SC. D.
DIRECTOR OF RESEARCH
A.R.F. PRODUCTS, INC.
RATON, NEW MEXICO

HOME OFFICE AND MANUFACTURING PLANT - RATON, NEW MEXICO
RESEARCH AND DEVELOPMENT LABORATORY - BOULDER, COLORADO

23 October 1978

A COMPARISON BETWEEN
SSB AND FM MODULATION PROCESSES
IN A NEAR FIELD MEDIUM FREQUENCY
WIRELESS COMMUNICATION SYSTEM

By

Larry G. Stolarczyk, Sc.D.
Director of Research
A.R.F. Products, Inc.
Raton, New Mexico

Prepared for:

United States Department of the Interior
Bureau of Mines
4800 Forbes Avenue
Pittsburgh, Pennsylvania 15213

1.0 FRAMEWORK FOR COMPARISON

This document describes the decision factors that bear on the selection of the modulation process for the wireless underground medium frequency (MF) communication system.

The selected modulation process must satisfy the Bureau of Mines stated objective of improving general communications within an underground mine. The improvement being sought includes the development of a wireless communication technology of measurable benefit to both mine safety and mine productivity.

The improvement will allow wireless communications paths to exist between roving miners. The wireless communication paths will also be made compatible with the existing underground telephone system to extend paging and voice communication throughout the underground mine.

The new wireless equipment will include man-pack, vehicular, repeater, and base station transceivers. Repeaters and base stations will feature coupling networks for interfacing with the existing telephone circuits.

Frequency modulation (FM) and single sideband (SSB) modulation processes are analyzed in view of the special conditions associated with underground mining. Of primary importance is the tremendous electrical noise generated in an operating mine that could adversely affect communications quality.

High noise coupled with high attenuation rate of near field signals forces the communication system to be inherently short range. Fortunately, near field signals can propagate over great distances on underground wires and cables.

The framework for comparison is generated by presenting all factors that

bear on the problem. Then alternative modulation processes are considered in terms of the advantages and disadvantages of the factors as they bear on the problem. Finally, the best alternative modulation process is recommended for the wireless mine communication system.

LIST OF DECISION FACTORS

Factor 1: The signal level must exceed the noise level by reasonable margin.

For acceptable communications quality, the signal power must always exceed the noise power within the transmission bandwidth by a considerable margin within the useful operating range of the system.

Therefore, a useful communications limit is reached when the noise power presented to the input of the receiver becomes comparable with the signal power.

Factor 2: System must be capable of wireless communications along haulage ways.

Communications with miners along haulageways using wireless techniques will be an essential improvement in the present underground mine communication system.

Underground haulage includes rail and conveyor (belt) systems. In recent years, conveyor haulage systems have emerged as a significant alternative to the rail haulage systems. The wireless communication system must be compatible with and useful in both systems.

Factor 3: Medium frequency signals offer best propagation characteristics in an underground mine.

The "propagation" characteristics of medium frequency (MF) signals in an underground mine have been experimentally measured (5) and theoretically studied (6). The transmission of MF signals relies on the propagation or coupling of magnetic fields between a transmitter and a remote tuned loop receiving antenna.

The magnetic coupling or near field mode of signal transmission has been known for a long time. The distinguishing characteristic of

near field transmissions is that the field strength rapidly decreases with distance from the transmitter. Depending on the conductivity of the coal, the field strength attenuation ranges between 10 to 40 dB for each doubling of range. By way of comparison, the propagation characteristics of the radiated field in free space decays at the rate of 6 dB for each doubling of range.

Near field communication systems have a unique extended range capability since other nearby conductors can act as a low loss transmission medium for magnetic signals. During the war years in Europe, communications over "cut" telephone lines were made possible by near field transmission schemes. It is the magnetic coupling characteristic that will be exploited in the wireless mine communications problem.

While it is true that communications will be required in conductor free areas, operating distance will be relatively short with abrupt loss of signal in the fringe zones. This is contrasted to radiated signals that exhibit a gradual loss of operating system quality as the distance from the transmitter is increased through the fringe zone.

Factor 4: Magnetic field sensors are more efficient than electric field sensors in practical mine communication systems.

Electric field sensors are very insensitive at lower frequencies and cannot be used in a practical mine communication system.

At an air-earth interface, only the magnetic field is essentially undisturbed while the electric field is severely reduced.

Any current will induce magnetic fields and hence the magnetic field

will directly be related to current flow. Thus, magnetic field sensors such as tuned loop antennas are effective sensors of low frequency communication signals. The signals may propagate along a conductor in a transmission line mode or be part of the near field in the vicinity of an excited conductor.

Factor 5: Electrical noise generated in the mine power system greatly influences the selection of the modulation process and the design of the transceiver.

The electrical noise generated in the mine power system becomes a dominant factor in the underground wireless communications problem.

A review of the measured noise data (6) (7) reveals the noise field strength varies over an enormous range (by several orders of magnitude - 60 to 130 dB variation). The noise is greatest near AC to DC converters (rectifiers), and along the trolley wire in rail haulage systems. Away from haulageways, the mine noise level is as much as 40 to 50 dB below the noise level in the haulageway. The noise levels also change over a large range during a typical mine work shift. Below 100 kHz, changes are of the order of 45 to 50 dB decreasing to about 25 to 30 dB for frequencies around 1 MHz.

The frequency dependence of the envelope of the measured noise spectrum exhibits some noteworthy characteristics.

a) The mine generated noise level decreases with frequency.

Between 3 kHz and 100 kHz, the typical envelope of the noise decreases by 50 to 70 dB, depending upon the type of electrical equipment operating in the vicinity of the noise measurement.

b) For frequencies below 50 kHz, the envelope of the noise spectrum decreases rapidly. The average rate is approximately 14 dB per octave; however, rates as high as 20 dB per octave are

evident over limited frequency ranges.

- c) For frequencies above 100 kHz, the envelope of the noise spectrum decreases at the rate of 6 dB per octave.

The electrical machinery used in a mine creates a wide range of many types of intense electromagnetic interference (EMI). Each type of electrical apparatus exhibits a noise signature that can be recognized in the spectrum analysis of noise signals.

To further expand and analyze the mine noise data (6) (7), time domain measurements were made on common types of equipment. The time domain measurements show that mine noise is predominantly generated by recognizable periodic waveforms. These waveforms have Fourier transformations with specific frequency domain characteristics.

Recognition of the periodic characteristic of mine noise signals is valuable since the results can be used to design a better wireless communication system.

The time domain characteristics of trolley rectifiers and power centers will be described by actual measurements. Then the frequency domain characteristics will be described in detail.

The trolley rectifier represents one of the noisier locations in the mine. Rectifiers include a three phase step-down transformer. The secondary of the transformer drives a full wave bridge rectifier. Similar AC to DC rectifiers are also found in power centers feeding working areas in the mine.

Two different types of time domain measurements were made on the rectifier.

In the first measurement, the voltage appearing between the pilot and

ground conductor in the high voltage (7100 VAC) cable feeding the rectifier was measured with an oscilloscope. The measured voltage is representative of current flowing in the feeder cable. The result is shown in Figure 1.0:

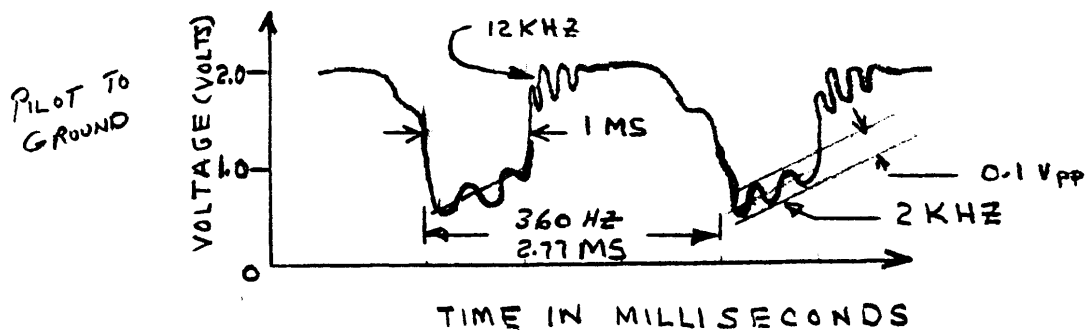

Figure 1.0 Time domain characteristic of the induced pilot to ground signal measured in the U. S. Steel Somerset Mine, Peona, Colorado.

The time domain measurements show the periodic characteristics of the signal.

The DC level varied with train movement. The level ranged between -0.5 and 5 volts and was caused by stray current flow along the railroad bed.

The strong 12 kHz and 2 kHz sinusoidal signature signals are noteworthy since similar signal components were also observed in the measured data of reference 8. These oscillations are probably caused by Ferro-magnetic resonances within the transformer feeding the full wave rectifiers.

The most striking feature of the measured noise is the periodic nature of the 360 Hz semi-rectangular pulse train. Each pulse represents the surge current flowing through each diode (6 each) in the full wave rectifier.

The trolley supply voltage characteristic provides further insight into the mine noise problem.

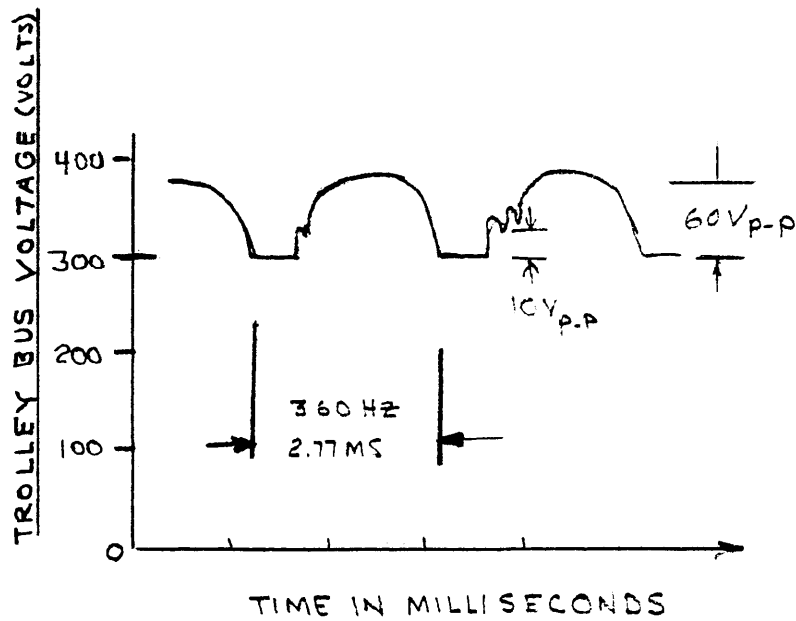

Figure 2.0 Time domain characteristics of the Trolley voltage in CF&I Allen Mine, Weston, Colorado.

Sequentially, line phase current flows into the trolley bus during each conduction period of the bridge rectifiers. On the decreasing part of the phase voltage cycle, the conducting bridge diode becomes reversed biased and current flow terminates. In a short period of time, the next bridge diode goes abruptly into conduction during the next current surge.

The repetitive pulses of current can be represented by rectangular pulse train of duration τ and period T . The Fourier series expansion of the pulse train is given by

$$f(t) = \frac{A}{\pi} \sum_{n=-\infty}^{\infty} \frac{1}{n} \sin(n\pi \frac{\tau}{T}) e^{jn(2\pi/T)[T - \frac{\tau}{2}]} \quad (1)$$

where A is the amplitude of the current pulse and n is an integer (harmonic order). The amplitude of the frequency spectrum can be written as

$$K = A \frac{\tau}{T} \left| \frac{\sin(n\omega_0 \tau/2)}{n\omega_0 \tau/2} \right| \quad (2)$$

The frequency spectrum will exhibit a frequency component at each harmonic of the current pulse rate (360 Hz). The level of the harmonic will decrease with the order of the harmonic (that is as $1/n$). The amplitude will follow

a $\sin \chi / \chi$ distribution with minimums of the distribution occurring whenever the argument of the sin function becomes equal to $n\pi$.

For the periodic waveform at hand, the harmonics of 360Hz do not occur at the minimums of the $\sin \chi / \chi$ distribution. The periodic waveform was applied to a spectrum analyzer and the resulting spectrum was plotted in two different frequency ranges.

Figure 3.0 shows the frequency range extending to 3 kHz. The spectrum shows the harmonics of 360 Hz. The spectrum exhibits a $\sin \chi / \chi$ amplitude dependence with minimums occurring every 997 Hz. These minimums are not at the zeroes of the $\sin \chi / \chi$ functions.

Figure 4.0 shows the frequency range used by trolley carrier current radio communication systems. It is not surprising to find that the commonly used 88 kHz frequency occurs at a minimum of the amplitude distribution.

For completeness, the time domain characteristic of the 88 kHz trolley carrier phone was measured as is shown in Figure 5.0.

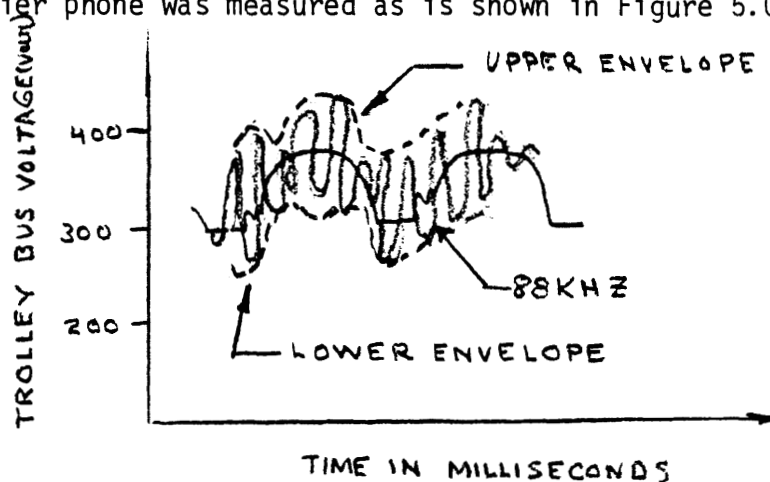

Figure 5.0 Time domain characteristics of the trolley voltage in CF&I Allen Mine, Weston , Colorado.

The 88 kHz carrier signal exhibits a peak signal voltage of 60V and is amplitude modulated to the extent of 70 percent.

FIG 3 & 4 ARE MISSING

The spectrum signature of induction motors exhibits two distinguishing characteristics. During startup the feed power cable pilot to ground voltage exhibits a triangular waveform with a repetition rate of 60 Hz. After startup, the voltage approaches a sinusoidal waveform.

The frequency spectrum of an induction motor EMI exhibits an amplitude spectrum with harmonics of 60 Hz decaying at the rate of $1/n$. Further, two spectral lines are sometimes evident: one at the "slip" frequency, the difference between the actual speed and the synchronous speed of the motor, the other at the synchronous speed of the induction motor.

The spectrum signature of arc welders has also been investigated by researchers at the Bureau of Standards (8). The EMI spectrum produces no strong spectral component. The amplitude characteristics of the spectrum go below the measurement system noise by 60 kHz. The power system also includes infrequent switching transients that can produce short duration noise pulses.

SUMMARY

The predominant EMI within an operating mine will be generated by periodic current pulses. The amplitude function of the resulting frequency spectrum will decay at the rate of $1/n$ where n is the harmonic of the 360 Hz pulse rate. Less significant EMI will be caused by induction motors, electrical arcs and switching devices. At low frequencies, below 100 kHz, the noise spectrum will decay at the rate of $1/n$ where n is the harmonic of the 60 Hz. Above 100 kHz, the noise spectrum decays at 6 dB per octave.

Factor 6: The repetitive EMI pulse train will cause the reactive networks in the wireless receiver signal path to exhibit a transient response behavior (ring).

The EMI reaching the receiver front end will be a periodic signal within the passband of the receiver.

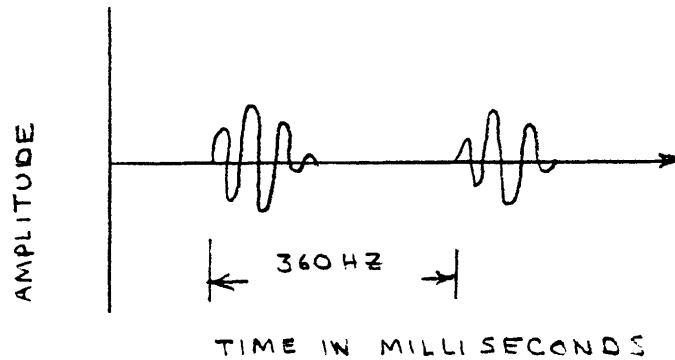

Figure 6.0 Time domain characteristic of the EMI signal in the receiver signal path.

Whenever the EMI signal exceeds the level of the legitimate signal, undesirable operation of the receiver occurs.

In general, the source of undesirable operation is the transient response behavior of the reactive networks in the signal path. The transient response behavior depends upon the transfer function of each reactive network. Linear phase transfer functions produce less over-shoot than do transfer functions with non-linear phase characteristics. The disturbances will be significant in the narrow-band highly selective circuits of the IF amplifier. Much smaller disturbances occur in single tuned stages of the tuned loop antenna, RF amplifier and mixer stages (single tuned networks exhibit nearly linear phase response characteristics).

Transient signals generated in the signal path are recovered in the receiver detector and appear in the audio output signal.

In an FM receiver, the limiter and discriminator networks may produce a transient response. The recovered audio signal will include both amplitude and frequency variations of the transient signal. The audio output will exhibit short duration damped sinusoidal pulses. It should be noted that if the damped sinusoidal frequency band occurs out of the audio passband, the resulting disturbance would not be noticeable.

In an SSB receiver, the product detector will recover both the amplitude and frequency variations of the transient signal. Further, the AGC network will respond to the product detector output signal by producing a gain control signal with its own transient characteristics. The actual audio output disturbance is much greater in an SSB receiver.

Noise blanker circuits can be designed to reduce noise pulse interference. Noise blanker circuits prevent the noise pulse from reaching the highly selective circuits of the IF amplifier. This can be achieved in a number of ways. However, the most common method is to open the receiver signal path immediately after the first mixer. Other methods include lowering either the RF or mixer gain. These approaches are less satisfactory since they introduce new transients upon the restoration of normal gain.

There are some pitfalls that must be recognized in a noise blanker design. First of all, the detection of the noise blanker signal must be made out of the frequency range of the legitimate signal. Otherwise, noise blanking will occur with the legitimate signal level. By selectively tuning the noise blanker circuits to an operating frequency below the system operation frequency range, an enhancement of the noise blanker detection process occurs. Figure 7.0 shows that the amplitude spectrum of the noise pulse increases with decreasing frequency.

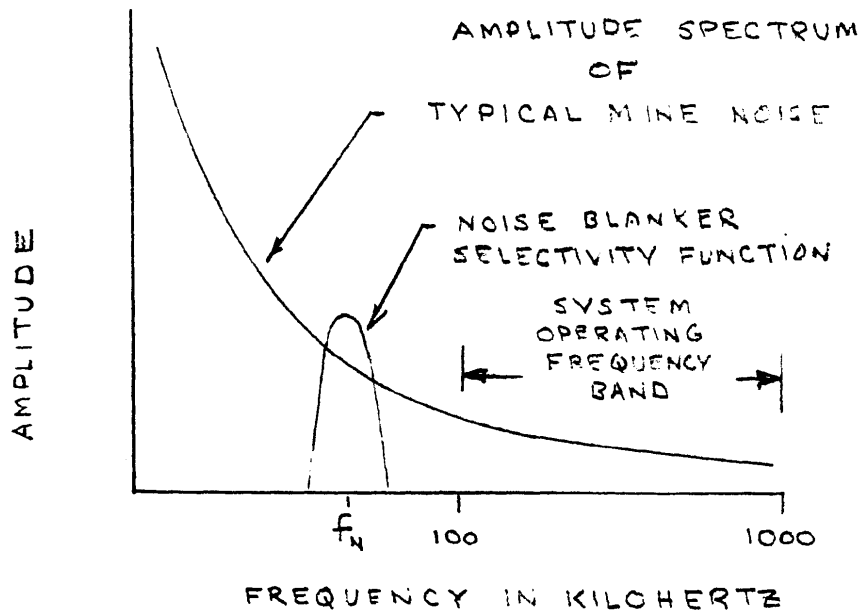

Figure 7.0 Typical amplitude spectrum of a noise pulse.

A noise blanker tuned to a frequency (f_N) below the operating frequency band will detect noise signals much greater in level than any noise signal appearing in the operating range of the system.

A further refinement in the design of the noise blanker is to include an AGC detector in the noise blanker circuit. The AGC should be designed to control the gain of the noise blanker such that only noise pulses above an average noise dependent threshold will result in blanking.

IMPULSE NOISE TESTING

FM and SSB receivers were evaluated using the test set-up below:

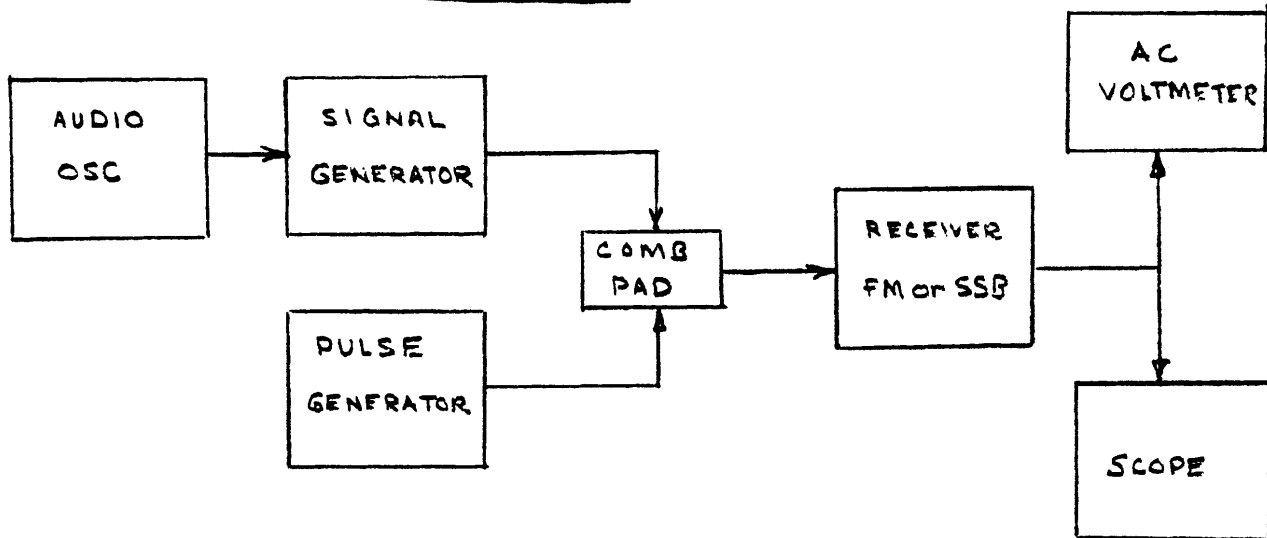

Figure 8.0 Impulse noise test set-up.

With the pulse generator turned off, the sensitivity of the receiver was determined by using a standard test signal defined by the Electronic Industries Association (EIA) for receiver test purposes. In the case of the SSB receiver the pulse generator is initially turned off. The signal generator (CW mode) is tuned to 1 kHz above the receiver operating frequency. The CW signal level is increased until the receiver output signal is 10 dB above the output noise when the signal generator is turned off. The pulse generator is then turned on and the controls set to provide a recurring pulse signal at the 360 Hz rate. The pulse width is set to 1 millisecond. The CW signal generator level is increased until the output signal to noise ratio is again 10 dB. The difference between the initial and final generator level setting is a figure of merit (not to exceed 10 dB).

The behavior of the SSB receiver output signal with a recurring noise pulse was studied with the oscilloscope shown in Figure 8.0. The particular SSB receiver included an inband noise blanker. For pulse rise times of more than 1 microsecond, the noise blanker effectively reduced

the pulse interference as the rise time approached .1 microsecond. (The EMI signal in the receiver passband increases by 20 dB when pulse rise time is reduced to .1 microsecond). The recovered output became noisy at the 360 Hz pulse rate. When the signal generator level was increased above 30 microvolts, the effect of noise in the audio output disappeared. The output noise appeared to be silenced because the signal level exceeded the pulse noise (See Figure 6.0) within the bandwidth of the receiver.

An FM receiver was evaluated in the same way except the signal generator was frequency modulated with a peak frequency deviation of ± 5 kHz. The audio output of the receiver exhibited a damped sinusoidal behavior. The SSB receiver response to a noise pulse is determined by the transient behavior of the automatic gain control (AGC) network.

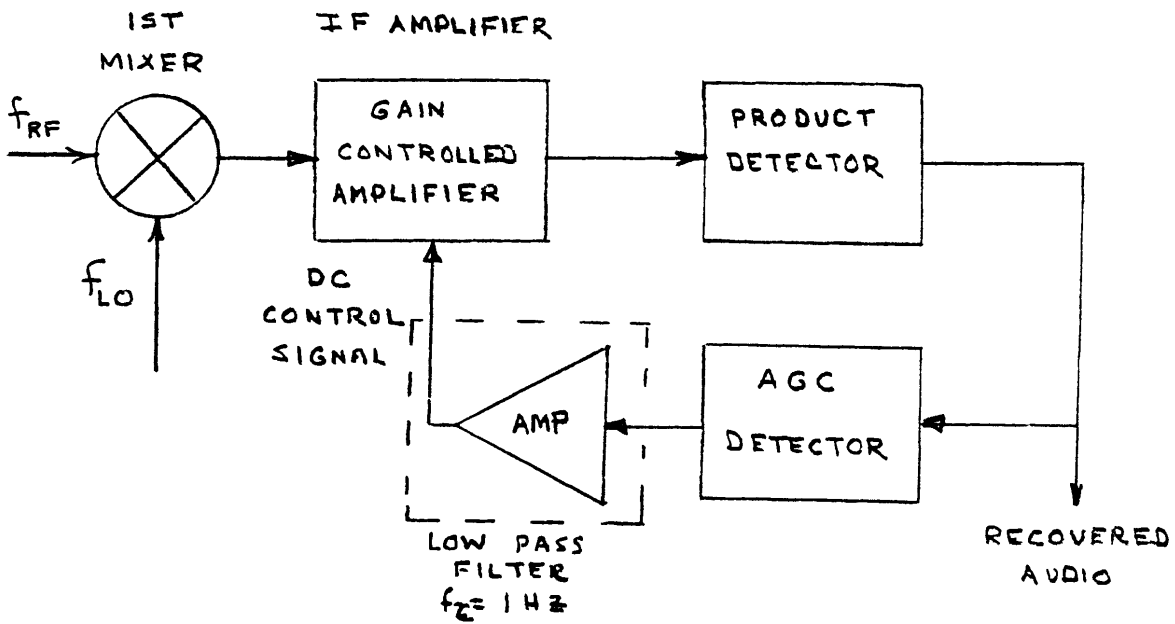

Figure 9.0 SSB receiver automatic gain control network.

The AGC network is a closed loop feedback network. The IF amplifier gain is controlled on the basis of holding the peak value of the recovered audio signal constant during the spoken word. The DC control signal is derived by detection of the product detector output signal (recovered audio signal).

The AGC control loop is designed to have a fast attack and slow release time constants. In practice, the attack time constant is selected to be 10 milliseconds or less to avoid first syllable "thumps" at the beginning of each word. The release time is greater than 10 milliseconds.

A major problem in the design of the AGC control loop is that it must not respond to signals in the voice frequency band. Therefore, the AGC control loop must exhibit a very low cut-off frequency. The low cut-off frequency of the AGC loop extends the release time of the network to seconds.

An SSB receiver will respond to a noise pulse by immediately lowering the signal path gain for a period of time equal to the release time of the AGC circuit. Each recurring noise pulse is evident in the recovered audio signal.

The FM receiver produced recovered audio pulses at the 360 Hz disturbance frequency. The damped sinusoidal frequency was well above the 3000 Hz frequency of the receiver audio amplifier. The recovered noise disturbance was not as noticeable in the FM receiver as it was in the SSB receiver.

SUMMARY

A noise blanker network is required in the design of an SSB receiver to avoid receiver desensitization with noise pulses. A noise blanker will also extend the operating range of an FM receiver.

Factor 7: FM systems can offer noise quieting advantages when two conditions are satisfied:

- 1) The FM carrier to noise ratio must be greater than 13 dB, and
- 2) The FM modulation index ($\Delta F/f_m$) must be greater than approximately 0.6.

The modulation index of 0.6 defines the transition between narrow-band and wide-band FM. Narrow-band FM offers no improvement over SSB so far as the demodulation process is concerned. The FM noise improvement is due to the generation of signal components within the transmission bandwidth. The signal components act to overcome the noise components, thereby increasing the receiver output signal to noise ratio. Spread spectrum modulation processes always exhibit a very sharp threshold in the demodulation process. The threshold is the price that must be paid for improvement.

In an FM receiver, a noise pulse applied to receiver can cause the receiver output noise to increase during and after the noise pulse period. An FM limiter is not a substitute for a noise blanker. Without a noise blanker, a noise pulse can cause the limiter network to ring.

Factor 8: The action of a limiter in an FM receiver has been investigated by Davenport (1). A limiter being a device exhibiting a constant output power independent of input power will alter the signal to noise ratio in passing through the limiter.

The change in the signal to noise ratio of a signal passing through a limiter ranges between $\pi/4 < K < 2$, the lower band being approached for very low input signal to noise ratios, the upper band for very high signal to noise ratios.

Under low signal to noise ratio conditions the presence of a limiter in the signal path will degrade the system performance. Under high signal to noise ratio conditions, the limiter will enhance the quality of FM communications.

Factor 9: FM requires greater IF bandwidth than an SSB communication system.

The required bandwidth for an SSB communication system is equal to the voice baseband frequency range.

The bandwidth required in an FM system is given by Carson's Rule as:

$$BW = 2 \Delta f + 2 f_m \quad \text{or}$$

$$BW = 2M \Delta f \quad \text{when } M > 1$$

where Δf is the peak frequency deviation of the carrier signal and m is the modulation index ($\Delta f/f_m$).

When the modulation index is high, the required bandwidth is independent of modulation frequency.

Sensitivity based upon SINAD measurements will exhibit degradation whenever the peak deviation $\pm \Delta f$ exceeds 75% of the IF bandwidth. The modulation acceptance bandwidth is characterized by the frequency deviation required to produce 12 dB SINAD for a specific signal that is 6 dB larger than a signal with a standard modulation that produces 12 dB SINAD sensitivity.

The FM bandwidth must be large enough to avoid the degradation effects of distortion. The FM receiver bandwidth ranges from 13 to 15 kHz in commercial grade FM transceivers ($\Delta f = \pm 5$ kHz).

The second order distortion in a narrow band FM system is given by:

$$D_2 = K (\Delta f)(f_m) \left| \frac{d^2 Q(\omega)}{d\omega^2} \right|$$

where $Q(\omega)$ is the phase response of the receiver selectivity function. Distortion increases with peak frequency deviation and modulation frequency (f_m). The distortion is also dependent upon the behavior of the phase response within the system transmission path bandwidth.

Factor 10: FM transceivers are less costly to design and manufacture.

The reasons for the lower cost are:

- 1) Low demand current FM IF amplifiers are available in integrated circuit form.

- 2) Monolithic quartz crystals are available for use in FM receivers.
These filters are less costly than SSB filters because they require lower resonator Q.
- 3) The design does not require ALC control circuits in the transmitter.
- 4) The local oscillator stability versus temperature specification is less critical for FM than SSB transceivers.

Factor 11: The SSB demodulation process does not exhibit a threshold effect. SSB demodulation is a linear process and will provide a paging capability even when the communication system is operating below threshold.

The SSB demodulation process is linear, meaning that the signal to noise ratio is not changed in the demodulation process at low signal to noise ratios.

A very narrow band post-demodulation tracking detector can be used to detect paging and squelch control signals in areas of low carrier to noise operation. The tracking filter can extend the threshold of the communication system. The roving miner can be paged even when voice communication quality is poor. The miner can then move closer to a repeater or base station to establish quality voice communications.

Factor 12: The narrow band FM articulation index is about the same as SSB.

A comparison of SSB and FM modulation systems based upon articulation index consideration shows that for a peak envelope power to noise power density in dB - Hz of less than 40 dB, FM ($m = 1$ or 2) has no advantage over SSB.

Factor 13: The sensitivity of an SSB receiver is better than a narrow band FM receiver by approximately 2.0 dB.

The sensitivity improvement of SSB over FM is given by

$$10 \log_{10} \left| \frac{BW_{FM}}{BW_{SSB}} \right|$$

where BW is the required signal transmission bandwidth.

The SSB system will exhibit better threshold sensitivity.

Factor 14: SSB transmitter is more efficient.

SSB will require less battery capacity and hence smaller physical battery volume.

Considerations:

1) SSB Class AB or B final amplifier efficiency of 38%;

FM Class C final amplifier efficiency of 50%.

2) During voice transmission SSB speech tacks requires approximately 50% less battery power.

FM speech transmission with a VOX circuitry requires full transmitter output for the duration of the speech transmission.

The transmit period battery consumption is less for SSB transmissions.

Factor 15: Selective fading less in SSB communication system.

SSB modulated signals have an advantage over FM and AM if selective fading is likely to occur in the transmission path. Dispersive medium and multiple path effects can suppress carrier signals and degrade the demodulation processes.

Since SSB does not require a carrier signal in the demodulation process, the SSB transmissions are less susceptible to these effects.

Factor 16: Spurious receiver desensitization depends upon frequency transposition process.

Spurious response depends upon the receiver transposition scheme. FM communication systems require wider IF bandwidths and are therefore more susceptible to spurious response desensitization.

Factor 17: A tone controlled squelch will be required in the operating wireless communication system.

An audible tone controlled squelch will be required.

Squelching schemes based upon noise detection cannot be expected to perform satisfactorily in the high noise environment of an underground mine.

In an FM system, subaudible tones will produce an FM signal with a high modulation index. The FM detector threshold will not allow proper operation whenever the carrier to noise level is low.

In an SSB system, subaudible tones recovered in the receiver output will include the frequency drift of both the transmitter and the receiver.

A coded squelch signal can be used for paging purposes.

Factor 18: FM communication system will be compatible with FM communications used in rail haulage applications.

Mining companies have already invested substantial sums of money in the trolley carrier current phone system. A wireless communication system that would be compatible with these communication systems would enhance mine safety.

Nearly all of the carrier current phone systems use FM modulation.

Factor 19: FM threshold extension not worth the effort.

Frequency modulation feedback (FMFB) and phase lock loop bandwidth compression can extend the threshold downward to a certain extent (a few dB) at the cost of considerable complication in the practical transceiver design. See article by J. J. Hupert (9).

Factor 20: Simple wire antennas can extend induction field range in an entryway.

Dedicated wire antennas can be used to transmit near field signals down haulageways. Wireless communications can be easily extended throughout the underground mine. Communications will be possible even across broken conductors. Dedicated conductors can avoid impulse noise problem likely to occur near power cables.

Factor 21: The design must be easily serviceable in the field.

Service is a major problem in a mine. The design must use plug-in PC boards wherever practicable. Service and repair manuals must be clearly written for mine personnel to use.

Factor 22: Collins MF Transceiver BW is 12 kHz.

$$\begin{aligned} BW &= 2\Delta f + 2 f_m \\ &= 2 (3 \text{ kHz}) + 2 (3 \text{ kHz}) \\ &= 12 \text{ kHz} \end{aligned}$$

COURSES OF ACTION

1.0 Select an FM system with a modulation index of 4 or greater.

Advantages:

- a) In a high carrier to noise ratio area, FM improvement could be realized. The modulation index would be 4 or slightly greater. The receiver transmission bandwidth (BW) must be wide enough to pass the FM spectrum without excessive distortion in audio quality. The required receiver bandwidth is defined as

$$BW = \frac{2 [m (f_m)]}{.75}$$

where m is the modulation index,

f_m is the highest audio frequency, and

.75 is a factor insuring that the receiver bandwidth is sufficiently wide for low FM distortion transmissions.

The required receiver bandwidth becomes

$$BW = \frac{2 [4 (2200)]}{.75} = 23,466 \text{ Hz}$$

- b) The transceiver local oscillator frequency stability versus temperature specification is realizable with a commercial grade quartz crystal oscillator.
- c) The noise impulse response would be less than in an SSB system.

Disadvantages:

- a) In low carrier to noise ratio areas, FM threshold would seriously degrade audio quality.
- b) System could not be used for paging purposes in noisy areas of the mine.

- c) A limiter will degrade the output signal to noise ratio in noisy areas of the mine.
- d) The receiver will have increased susceptibility to spurious response owing to the wide IF bandwidth.
- e) Wide signal spectrum requires wide band transmitter final circuits. At low (and medium) frequencies this leads to low-Q circuits. These cannot, however, be efficiently loaded by the radiation resistance, since the system does not operate by means of the radiated field, but rather by an induction field. Wider band necessitates, then, higher antenna circuit loss, reduces circulating current and thus the transmit moment. This is a powerful factor militating against even a relatively narrow-band FM system.

2.0 Select a narrow band FM system.

Advantages:

- a) Although FM improvement would not be possible in the system, the effect of threshold could be avoided in the communication system. The modulation index would be less than unity to avoid threshold effects. The required receiver bandwidth for acceptable audio quality becomes

$$\begin{aligned}
 \text{BW} &= 2 \frac{(.6)(2200)}{.75} \\
 &= 3520 \text{ Hz}
 \end{aligned}$$

The voice band would extend to 2200 Hz and is adequate for good legibility.

- b) The transceiver local oscillator frequency stability versus

temperature requirement is realizable with a commercial grade quartz crystal oscillator.

Disadvantages:

- a) No demodulation improvement over SSB.
- b) In areas of low signal to noise ratio, receiver limiter will degrade the output SIN ratio by 1 dB.
- c) Since the final power amplifier can be operated in Class C, the transmitter harmonic output will be greater than in a Class AB or B SSB design. A more complex harmonic filter will be required. However, the cost of the additional filter element will be less than \$1.00.
- d) In a receiver with a properly designed noise blanker, a noise pulse will cause the receiver output noise to increase for the duration of the blanking period.
- e) In high carrier to noise ratio areas, the receiver limiter will improve the output signal to noise ratio by 3 dB.
- f) If the receiver can be tuned to frequencies used by the existing carrier current trolley telephones, the transceiver can be simply added to some existing mine communication system.
- g) The noise impulse response would be better than in an SSB system. A noise blanker can extend the operating range of the FM receiver.
- h) A very narrow band tracking filter following the discriminator can be used to detect paging and squelch control signals. The tracking filter can extend the threshold of communication system for paging and squelch control purposes.

3.0 Select an SSB system.

Advantages:

- a) The demodulation system is linear and threshold effects are avoided.
- b) The receiver bandwidth only needs to be as wide as the highest voice band frequency (BW = 2200 Hz). The receiver will have a sensitivity advantage over narrow band FM. The improvement may be less than 2 dB.
- c) More communication channels can be used in a given bandwidth.
- d) In a receiver with a properly designed noise blanker, a noise pulse will cause the receiver output audio signal to become quiet instead of a full noise output as is the case in FM.
- e) The antenna Q can be the highest possible to reduce circuit loss, allow maximum circulating current and thus a high transmit magnetic moment.
- f) Since the system need not transmit during pauses in the voice signal, the highest overall efficiency is achieved.
- g) A below threshold paging capability can be realized by using a narrow band tracking filter and decoder following the receiver product detector.

Disadvantages:

- a) To avoid spurious receiver response problems, a high IF frequency must be used in the design. This forces the first mixer injection oscillator to have a frequency stability versus temperature of ± 1 PPM. The required crystal oscillator will cost considerably more

- than a commercial grade oscillator for an FM system. The cost may exceed \$100 in production quantities.
- b) The IF circuits must include a means of sharing the IF crystal filter in both the transmit and receiving modes of operation. This adds complexity to the design.
- c) Receiver AGC must have a short attack and release time to prevent receiver desensitization after a noise pulse. There are problems in achieving this objective because the fast release SSB AGC networks are difficult to stabilize with voice modulated SSB signals.

RECOMMENDATIONS

Voice quality communications will require that the signal path carrier to noise power ratio exceed 10 dB throughout the required operating range. The system must include a network of dedicated conductors, repeaters and antennas to maintain the signal path signal to noise ratio.

Rail haulage communications can be improved by use of a tuned filter between the trolley rectifier and the trolley bus. The filter should be tuned to the operating frequency of the MF communication system. A dedicated trolley communication line would improve the communications quality. Power line filters could be used elsewhere in the mine to reduce EMI.

In general there are no miracles in establishing voice quality communications in an operating mine. The present trolley mine phones which operate in the noisiest part of the mine simply overpower the noise. The general characteristics of trolley telephones are shown below:

Manufacture	Transmitter Output Power
Pyott Boone	15 Watts
Femco	16 Watts
MSA	20 Watts

Manufacture	Type of Modulation	Receiver BW Sensitivity
Pyott Boone (#214)	FM	5 kHz 420 uV
Femco (731901)	FM Some AM	5 kHz 480 uV
MSA (1601)	FM Some AM	13 kHz 820 uV

The data shows that the combination of high transmitter power and low receiver sensitivity solves the noise problem in the trolley communication system.

Narrow band FM does not offer any significant improvement over SSB wireless communications. Although the SSB receiver sensitivity can be made 3* dB better than a narrow band FM receiver, the system operating range improvement is small because of the high attenuation of near field signals. The pivotal point in the selection of the modulation process is the relatively high cost of stable local oscillators required in an SSB communication system (required to avoid spurious receiver responses). Further, accidental shock (drop) to the transceiver could seriously degrade system voice quality whenever the oscillator frequency drifted more than 20 Hz from the required channel frequency.

An SSB transceiver is more complex to design and manufacture, since the IF filter (quartz crystal filter) must be shared between TX and RX mode of operation. A transmitter automatic level control and a receiver automatic gain control are required in the design.

A final point bearing heavily on the selection is that a noise blanker is necessary in the SSB receiver to avoid receiver desensitization under repetitive noise pulse EMI. However, this argument against SSB may be weak, since a noise blanker applied to an FM receiver will improve the system performance in the vicinity of high impulse noise (around rectifiers).

* 2 dB from smaller noise bandwidth and 1 dB from the FM limiter operating at low SIN.

Narrow band FM wireless communication system is recommended.

The receiver to be free of spurious response (IF greater than 5 MHz) and the transmitter spurious emission to be down better than 70 dB. The receiver design to include a noise blanker tuned to a frequency below 88 kHz. The frequency range of the system to include 88 kHz trolley mine phone frequency.

LIST OF REFERENCES

1. Panter, P. F. Modulation, Noise and Spectral Analysis, McGraw-Hill Book Company, New York; 1965.
2. Viterbi, A. J. Principles of Coherent Communications, McGraw-Hill Book Company; 1966.
3. Hancock, J. C. The Principles of Communication Theory, McGraw-Hill Book Company; 1961.
4. Davenport, W. B. and Root, W. L. An introduction to the Theory of Random Signals and Noise, McGraw-Hill Book Company, 1958.
5. Cory, T. S. Propagation of FM signals in Underground Mines, United States Dept. of the Interior, Bureau of Mines, Contract No. H0366028; Final Report; September, 1977.
6. Lagace, R. L. Transmit Antennas for Portable VLF to MF Wireless Mine Communications, USBM Contract Final Report (H0346045), Task C Task Order No. 1; May, 1977.
7. Scott, W. W., et al Electromagnetic Noise in Lucky Friday Mine, a Technical Report of Electromagnetics Division, Institute for Basic Standards, National Bureau of Standards, Boulder, Colo. 80302; June, 1974.
8. Kanda, M., et al Electromagnetic Noise in McElroy Mine, a Technical Report of Electromagnetics Division, Institute for Basic Standards, National Bureau of Standards, Boulder, Colo. 80302; June, 1974.
9. Hupert, J. J. "Frequency Modulation Techniques", Electro-Technology, February, 1965.