

ANALYSIS OF LONGWALL TAILGATE SERVICEABILITY (ALTS): A CHAIN PILLAR DESIGN METHODOLOGY FOR AUSTRALIAN CONDITIONS

By Mark Colwell,¹ Russel Frith, Ph.D.,² and Christopher Mark, Ph.D.³

ABSTRACT

This paper summarizes the results of a research project whose goal was to provide the Australian coal industry with a chain pillar design methodology readily usable by colliery staff. The project was primarily funded by the Australian Coal Association Research Program and further supported by several Australian longwall operations.

The starting point or basis of the project was the Analysis of Longwall Pillar Stability (ALPS) methodology. ALPS was chosen because of its operational focus; it uses tailgate performance as the determining chain pillar design criterion rather than simply pillar stability. Furthermore, ALPS recognizes that several geotechnical and design factors, including (but not limited to) chain pillar stability, affect that performance.

There are some geotechnical and mine layout differences between United States and Australian coalfields that required investigation and, therefore, calibration before the full benefits offered by the ALPS methodology could be realized in Australia.

Ultimately, case history data were collected from 19 longwall mines representing approximately 60% of all Australian longwall operations. In addition, six monitoring sites incorporated an array of hydraulic stress cells to measure the change in vertical stress throughout the various phases of the longwall extraction cycle. The sites also incorporated extensometers to monitor roof and rib performance in response to the retreating longwall face.

The study found strong relationships between the tailgate stability factor, the Coal Mine Roof Rating, and the installed level of primary support. The final outcome of the project is a chain pillar design methodology called Analysis of Longwall Tailgate Serviceability (ALTS). Guidelines for using ALTS are provided.

¹Principal, Colwell Geotechnical Services, Caloundra, Queensland, Australia.

²Principal, Strata Engineering, Teralba, New South Wales, Australia.

³Supervisory physical scientist, Pittsburgh Research Laboratory, National Institute for Occupational Safety and Health, Pittsburgh, PA.

INTRODUCTION

In many cases, chain pillars in Australia have been designed solely with regard to pillar stability using a process similar to that used for pillars within bord-and-pillar operations. The bord-and-pillar approach is based on analysis of collapsed pillar cases from Australia and the Republic of South Africa [Salamon et al. 1996] and applies a factor of safety in relation to pillar collapse. This approach is inappropriate for a number of reasons when designing chain pillars.

Australian chain pillars typically have minimum width-to-height (w/h) ratios >8 , which is approximately 4.5 standard deviations away from the mean of the pillar collapse case histories. In addition, the chain pillar loading cycle and active life are significantly different from those experienced by pillars within a bord-and-pillar operation. Finally, the goal of maintaining gate road stability is very different from that of avoiding a pillar collapse.

The need for a design method uniquely developed for Australian longwall chain pillars was clear. The original submission for funding by the Australian Coal Association Research Program (ACARP) stated that the calibration (to Australian conditions) of a proven chain pillar design methodology offered the least risk for a successful and timely outcome. It was assessed that the most comprehensive chain pillar design tool then available was the Analysis of Longwall Pillar Stability (ALPS) [Mark 1990; Mark et al. 1994]. The primary consideration in selecting ALPS is that it uses gate road (i.e., tailgate) performance as the determining chain pillar design criterion. Secondly, ALPS is an empirical design tool based on a U.S. coal mine database; thus, it provided a ready framework for calibration to Australian conditions.

The aim of the project was to provide the Australian coal industry with a chain pillar design methodology and computer-based design tool readily usable by colliery staff. A further objective was to ensure that the methodology developed by the project had the widest possible application to all Australian coalfields by identifying where local adjustments and limitations may apply.

In formulating the design methodology, the primary goal was to optimize pillar size (specifically pillar width) so as to—

- Maintain serviceable gate roads such that both safety and longwall productivity are unaffected;
- Minimize roadway drivage requirements so as to have a positive impact on continuity between successive longwall panel extraction; and
- Maximize coal recovery.

In designing chain pillars, specifically with regard to satisfactory gate road performance, the following design criteria were proposed:

- The chain pillar must provide adequate separation between the main gate travel road and belt road, such that the travel road (tailgate of the subsequent longwall panel) will be satisfactorily protected from the reorientation and intensification of the stress field caused by the extraction of the first longwall panel.
- The tailgate (with a focus on the tailgate intersection with the longwall face) will be sufficiently serviceable for ventilation and any other requirements (setting of secondary support, second egress, etc).

BACKGROUND

ALPS was originally developed by Mark and Bieniawski [1986] at The Pennsylvania State University. It was further refined [Mark 1990, 1992; Mark et al. 1994] under the auspices of the former U.S. Bureau of Mines (USBM).⁴ The initial ALPS research involved field measurements of longwall abutment loads at 16 longwall panels at 5 mines. These measurements were used to calibrate a simple conceptualization of the side abutment, similar to models proposed by Wilson [1981] and Whittaker and Frith [1987]. The side abutment (A) equates to the wedge of overburden defined by the *abutment angle* (ϕ) (see figure 1). The tailgate loading condition is considered to be some percentage of the side abutment, called the *tailgate abutment factor* (F_t). The U.S. field measurements found a range of abutment angles, from $\phi = 10.7^\circ$ to $\phi = 25.2^\circ$. A value of $\phi = 21^\circ$ and $F_t = 1.7$ was selected for use in design.

⁴The safety and health research functions of the former U.S. Bureau of Mines were transferred to the National Institute for Occupational Safety and Health in October 1996.

Because of the encouraging results obtained from the initial

study, the USBM commissioned further research directed toward quantifying the relative importance of roof and floor quality and artificial support on gate road performance. The approach was to analyze actual longwall mining experience. Case histories from 44 U.S. longwall mines were characterized using 5 descriptive parameters. Pillar design was described by the ALPS stability factor (ALPS SF = pillar strength \div pillar load); roof quality was described by the Coal Mine Roof Rating (CMRR) [Molinda and Mark 1994; Mark and Molinda 1996]. Other rating scales were developed for primary support, secondary support, and entry width.

Mark et al. [1994] reported that statistical analyses indicated that in 84% of the case histories the tailgate performance (satisfactory or unsatisfactory) could be predicted correctly using only the ALPS SF and the CMRR. It was further stated that most of the misclassified cases fell within a very narrow borderline region. The analyses also confirmed that primary

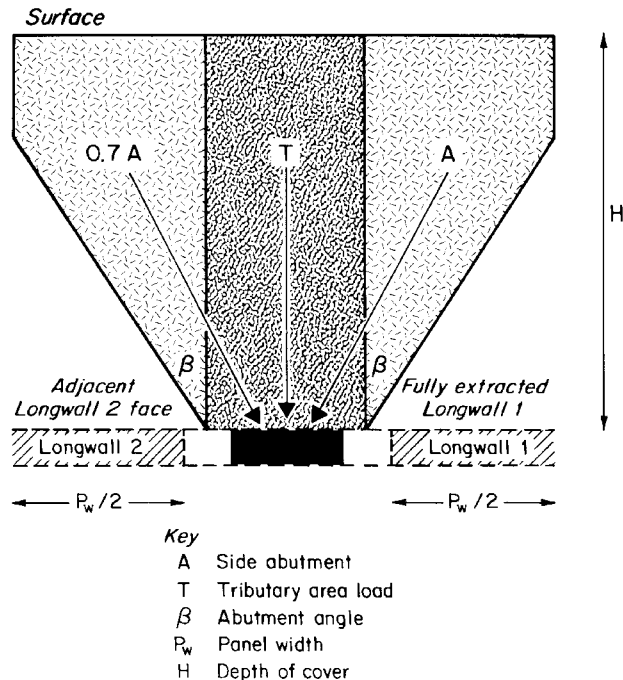

Figure 1.—Conceptual model of the side abutment load.

roof support and gate entry width are essential elements in successful gate entry design. The relative importance of the floor and of secondary support installed during extraction could not be determined from the data.

NEED FOR CALIBRATION

Conventional longwall mines in the United States generally use a three-heading gate road system; Australian longwall panel design typically employs a two-heading gate road system with rectangular chain pillars separating these gate roads. A typical Australian longwall panel layout is presented in figure 2. Figure 2 also details the stages of the chain pillar loading cycle:

1. Development loading (calculated using tributary area concepts);
2. Front abutment loading, which occurs when the first longwall face is parallel with the pillar;
3. Main gate (side) abutment loading, when the load has stabilized after the passage of the first face;
4. Tailgate loading, when the second face is parallel with the pillar; and
5. Double goafing, when the pillar is isolated between two gobbs.

It is during tailgate loading that the chain pillar (or cross section thereof adjacent to the tailgate intersection) experiences the greatest vertical loading during its "active life," i.e., the period where the chain pillar is playing its role in helping to maintain satisfactory gate road conditions. This project focused on tailgate performance (at the T-junction) as the design condi-

The following equation (relating the ALPS SF and CMRR) was presented to assist in chain pillar and gate entry design:

$$\text{ALPS SF}_R = 1.76 + 0.014 \text{ CMRR}, \quad (1)$$

where the ALPS SF_R is the ALPS SF suggested for design.

The Primary Support Rating (PSUP) used in ALPS was developed as an estimate of roof bolt density and is calculated as follows:

$$\text{PSUP} = \frac{L_b (N_b (D_b)}{S_b (w_e (84)}, \quad (2)$$

where L_b = length of bolt, m,

N_b = number of bolts per row,

D_b = diameter of the bolts, mm,

S_b = spacing between rows of bolts, m,

and w_e = entry (or roadway) width, m.

PSUP treats all bolts equally and does not account for load transfer properties, pretensioning effects, etc.

tion. The pillar stability factor in relation to the tailgate loading condition is designated as the "tailgate stability factor" (TG SF).

The project found that Australian chain pillars have an average length-to-width ratio of 3.2; crosscut centers on average are spaced at 100 m. The pronounced rectangular shape of Australian chain pillars may add strength to the pillar compared to a square pillar of the same minimum width. Mark et al. [1998b] reanalyzed the U.S. database using the Mark-Bieniawski rectangular pillar strength formula and found a slightly better correlation (in relation to the predictive success rate) than using the Bieniawski equation. In addition to the Bieniawski equation, this project assessed both the Mark-Bieniawski rectangular pillar formula [Mark and Chase 1997] and the squat pillar formula [Madden 1988] in relation to the correlation between the pillar stability factor and the CMRR.

In Australia, the significant impact of horizontal stress on coal mine roof stability is well documented [Frith and Thomas 1995; Gale and Matthews 1992]. The in situ horizontal stresses should not have a significant direct influence on tailgate roof stability due to the presence of an adjacent goaf. However, there is an indirect influence in terms of the degree of damage done to the roof during the initial roadway development and

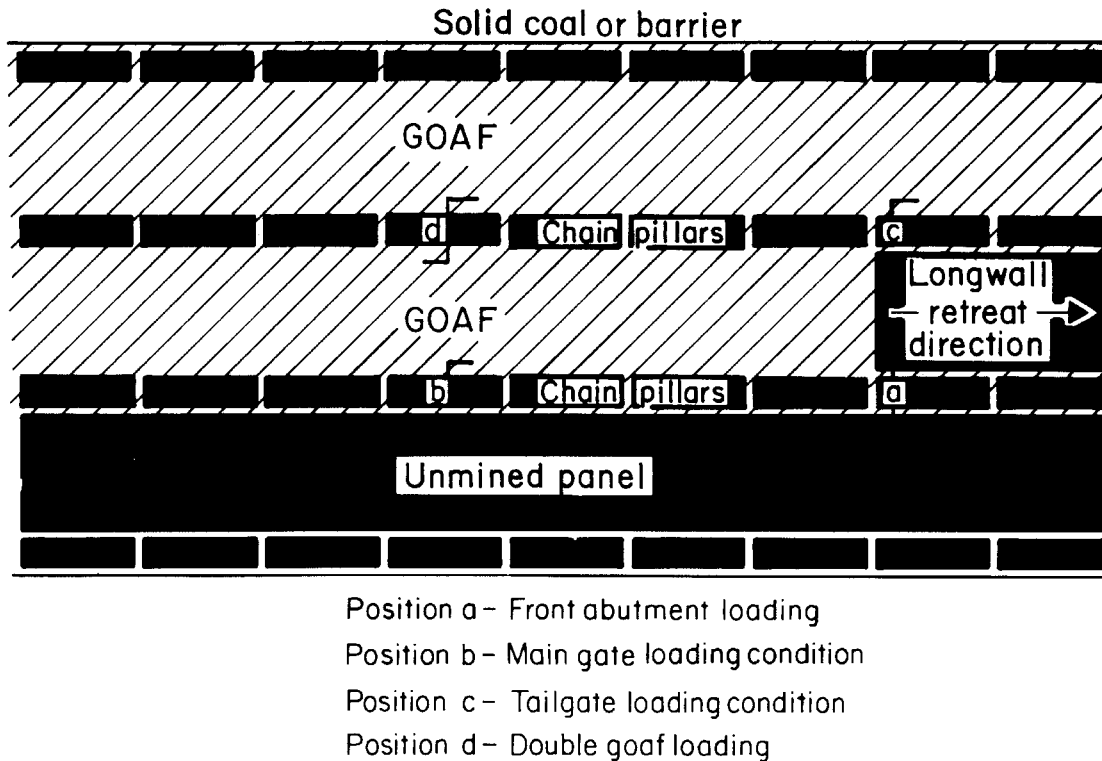

Figure 2.—Stages in the dynamic loading cycle of longwall chain pillars.

then to the main gate travel road and cut-throughs during longwall retreat. The effect of the in situ horizontal stress field on gate road serviceability (particularly on roof stability) is not taken into account directly by the ALPS methodology and was considered in more detail by the ACARP project.

Finally, the project aimed to verify the applicability of the ALPS loading parameters to Australian conditions. The ALPS methodology uses an abutment angle of 21° in all cases, and it assumes that the tailgate load is 1.7 times the side abutment load.

MEASUREMENTS OF AUSTRALIAN ABUTMENT LOADS

The project measured changes in vertical stress across (and within) chain pillars at six collieries to determine whether the ALPS approximations should be refined. Three sites were located in the Bowen Basin Coalfield in Queensland (Central, Crinum, and Kenmare Collieries), two were in the Newcastle Coalfield (Newstan and West Wallsend Collieries), and one was at West Cliff Colliery in the Southern Coalfield. Each monitoring site included an array of hydraulic stress cells (HSCs) generally located at midseam height to measure the changes in vertical stress. Most sites also included extensometers to monitor roof and rib performance. A general instrumentation layout is shown in figure 3.

The HSC used in this project is a modification of the borehole-platened flatjack developed by the former USBM. The HSC was developed, calibrated, and tested by Mincad Systems Pty. Ltd. [1997]. The HSC consists of a stainless steel bladder into which hydraulic fluid is pumped via tubing extending along the borehole. The bladder is encased between two steel platens that are forced against the borehole wall as the

bladder is pumped up.

As with every stress measurement instrument, proper calibration is important. Mincad Systems provided two calibration formulas based on its research with the HSC. The formula used in this project employs a calibration factor $K' = 1.0$ for a stress increase of $\#5$ MPa and $K' = 1.3$ for that portion of an increase above 5 MPa. Because ALPS is a comparative chain pillar design tool, it is not critical which calibration method is used as long as the method is consistent from site to site.

The six sites add considerably to the ALPS abutment load database. They include a much wider range of cover depths and width-to-depth ratios than the original U.S. data. There is also much more variety in the geologic environments. In addition, because the stress readings could be made remotely, monitoring was possible subsequent to the passing of the second longwall

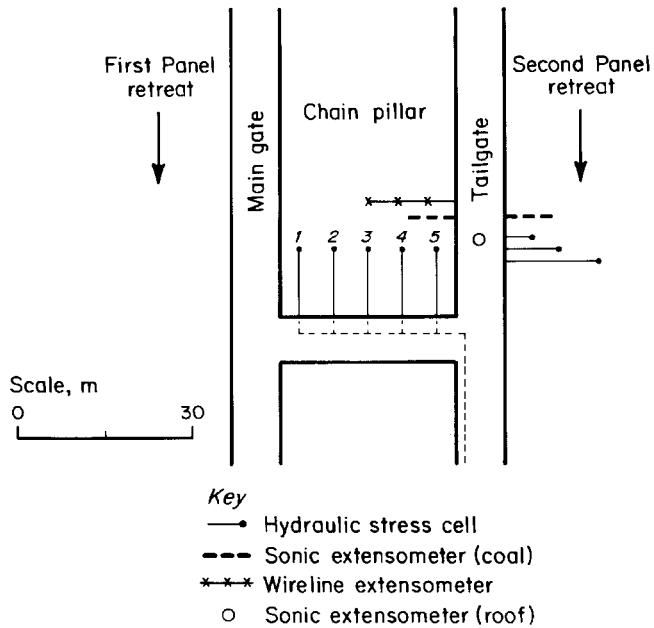

Figure 3.—Instrumentation layout at a typical stress measurement site.

face. Of the 16 original U.S. panels, there were sufficient data to characterize the side abutment load in only 6, and only one panel provided data on the tailgate abutment factor. In contrast, data on both the side and tailgate loads were obtained from all six Australian monitoring sites.

At the Australian sites, entry width and height ranged from 4.8 to 5.2 m and 2.5 to 3.6 m, respectively. Pillar width and length (rib to rib) ranged from 26 to 40 m and 95 to 125 m, respectively; cover depths varied from 130 to 475 m. Due to the relatively high length-to-width ratio of Australian chain pillars (i.e., extracted crosscut coal <5%), a plane strain or two-dimensional loading analysis is common in Australia and was considered appropriate by the Australian researchers. Furthermore, the Australian researchers recognized that the location of the stress cells within the pillar would in all probability affect the measured vertical stress changes. In placing the cells near a cut-through rather than across the longitudinal center of the chain pillar, the monitoring exercises were viewed as recording the loading behavior of a thin, two-dimensional slice of the pillar near a critical location during its "active life."

The ALPS loading parameters account for the extracted coal within the cut-throughs. Therefore, the abutment angles reported by the ACARP project [Colwell 1998] would be slightly different if the load had been addressed in the same manner as the U.S. field measurements in back-calculating the abutment angles. However, the end effect on the design chain pillar width is negligible.

Measurements of the main gate side abutment loading are used to calculate the abutment angle; measurements of the tailgate abutment (when longwall 2 is parallel with the instruments) are used to calculate the tailgate abutment factors. Examples of the data obtained from two of the sites are shown

in figure 4. The results from all six monitoring sites are summarized in table 1 and figure 5 (along with the U.S. data).

The measurements of the abutment angle from the three Queensland mines and from Newstan Colliery clearly fall within the range of the U.S. data. However, the abutment angles calculated for the two deepest mines, West Wallsend and West Cliff, are the smallest of any in the database. The overburden at these two mines (and at Newstan Colliery) also contains the massive sandstone and sandstone/conglomerate strata commonly associated with the Newcastle and Southern Coalfields. The low width-to-depth ratio, along with the strong overburden, may be affecting the caving characteristics of the gob.

Table 1 also shows two sets of tailgate abutment factors. The first set was obtained by dividing the measured tailgate loading by the measured main gate (side abutment) loading. The second set, which is the one used in the U.S. version of ALPS, is obtained by dividing the measured tailgate load (adjacent to the T-junction) by the *calculated* side abutment load using an abutment angle of 21° . The one U.S. measurement found this second tailgate abutment factor to be 1.7. The Australian data in table 1 show a high variability, with the mean at 1.3 in relation to an ALPS-style analysis.

Figure 6 plots the development of the change in load during tailgate loading (as a multiple of the side abutment) against face position. It clearly indicates that the nature of the loading behavior at Central, Crinum, and Kenmare Collieries closely approximates that proposed by ALPS. However, the tailgate loading behavior at Newstan Colliery and particularly at West Wallsend Colliery reveals that the *double goaf load* is significantly greater than twice the measured main gate side abutment load. It is likely that West Cliff would have behaved in a manner similar to Newstan if the cabling and/or cells had not become inoperable with the second longwall face only 5 m past the instrumentation site.

The field data associated with Newstan, West Wallsend, and West Cliff Collieries clearly suggest that a *much* greater portion of the main gate abutment load is distributed onto the adjacent unmined longwall panel than calculated on theoretical grounds (see figure 2).

Although the double goaf loading condition could not be measured at West Wallsend Colliery, it would seem that the bulk of the tailgate load manifests itself within that distance 100 m outby of the face. There are distinct increases in the rate of loading at approximately 70 m and again at 20 m outby of the face. This correlates well with the observed tailgate condition and strata behavior.

In contrast to West Wallsend Colliery, the bulk of the tailgate load at Newstan Colliery manifests itself after the passage of the longwall face. Both Newstan and West Wallsend Collieries have experienced greater difficulties with regard to both gate road and face control issues when massive sandstone/conglomerate channels are within 0 to 30 m of the mining horizon. Face width optimization has played a critical role in alleviating the face control difficulties.

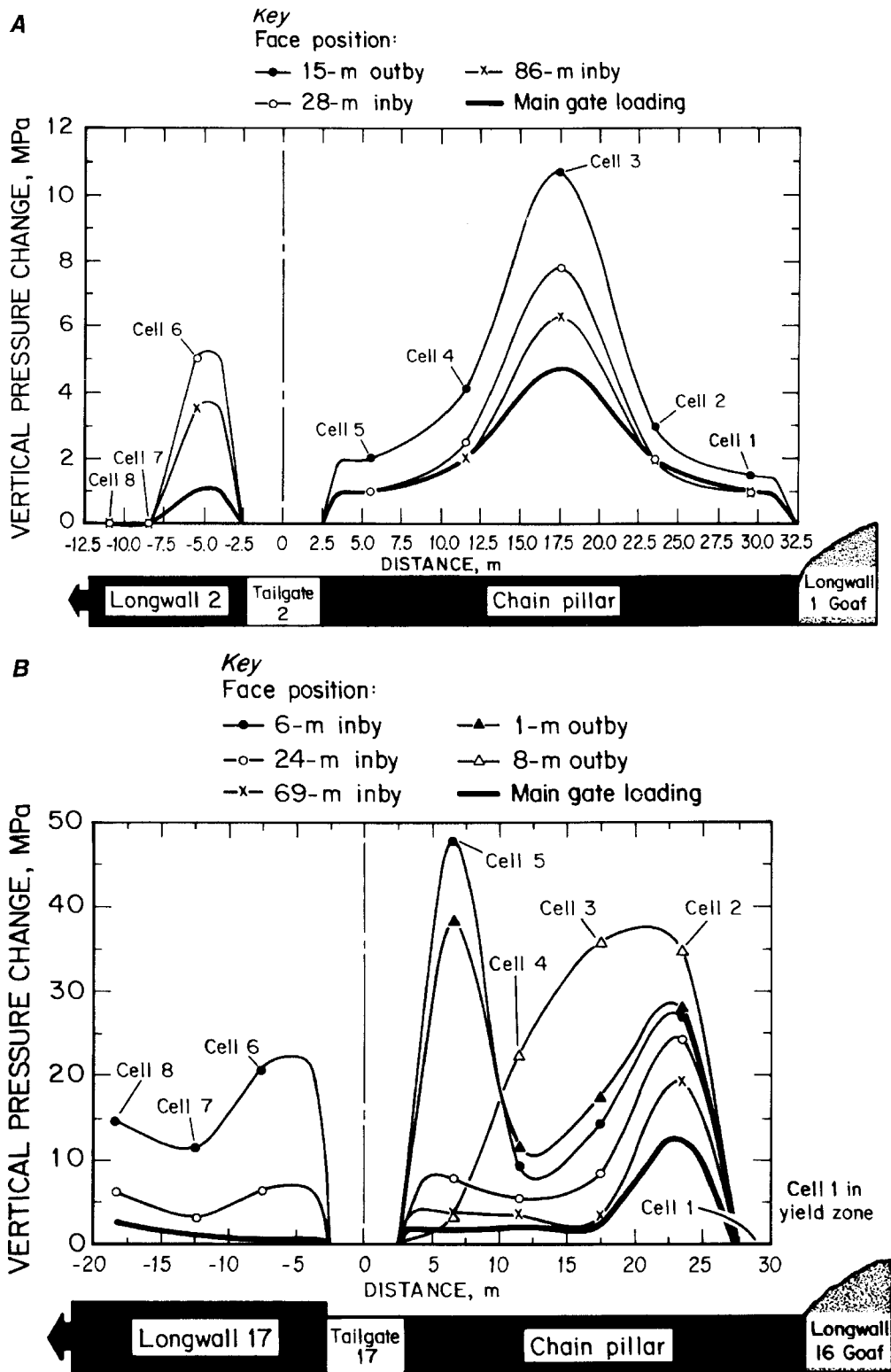

Figure 4.—A, Abutment load profiles at different locations of the longwall face (Crinum Colliery) with highly cleated coal. B, Abutment load profiles at different locations of the longwall face (West Wallsend Colliery), where the tailgate load is extremely aggressive.

Table 1.—Results of stress measurements

Monitoring site	H, m	w, m	w _p , m	P _w , m	β, °	F _t (Meas)	F _t (Calc)
Central	265	39.9	5.1	230	24.7	1.77	2.05
Crinum	125	30.2	4.8	275	19.1	1.52	1.35
Kenmare	130	24.8	5.2	200	19.2	1.49	1.22
Newstan	180	26.0	5.0	130	15.3	1.48	1.04
West Cliff	475	37.2	4.8	200	5.9	1.81	0.60
West Wallsend	240	30.1	4.9	145	8.5	3.79	1.52

NOTE.—β and F_t (Meas) are based on two-dimensional analyses (C = 0.25 MN/m³; Kenmare (C = 0.23 MN/m³). F_t (Meas) is based on ALPS loading parameters (β = 21° and C = 0.255 MN/m³).

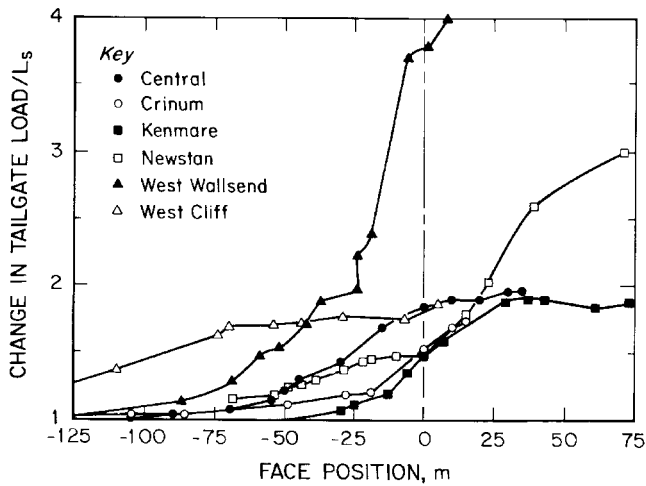

Figure 5.—Development of abutment load at the six monitoring sites.

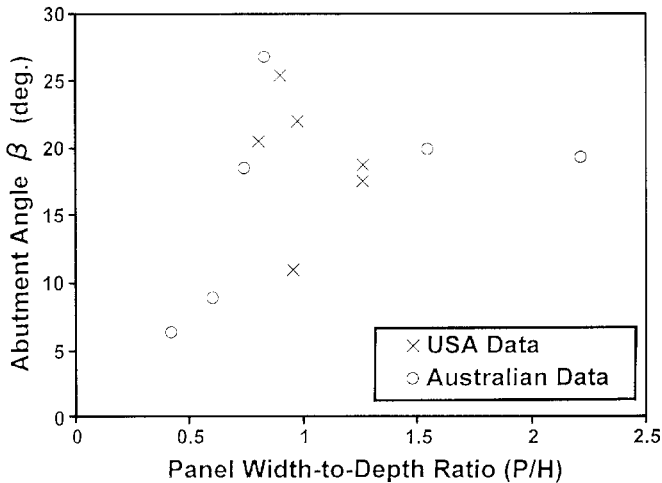

Figure 6.—Abutment angles determined from stress measurements.

A possible explanation for the variation in the manifestation of the tailgate load (in relation to face position) is that while a near-seam conglomerate channel exists in relation to the monitoring site at West Wallsend Colliery, it is absent at the Newstan Colliery site. The anecdotal evidence suggesting the near-seam channel as a possible cause of this variation in load manifestation is strong (i.e., secondary support requirements,

seismic monitoring [Frith and Creech 1997]; however, the mechanics are not yet fully understood.

The stress measurements collected by the project were supplemented by data from similar investigations previously conducted by other collieries, which were gratefully made available to the project. The supplementary field data were obtained using nearly all of the different types of stress cells that have been used in Australia (CSIRO HI, IRAD, Geokon, and HSC). The variety of instruments hinders comparison between studies, yet some trends emerge.

In general, the supplementary field data support the observations made from the project data. In Bowen Basin collieries, the loading behavior closely approximates that proposed within ALPS. In contrast, there are some significant departures in New South Wales for collieries that have strong, spanning overburden and a low width-to-depth ratio. Table 2 indicates that at Angus Place, South Bulli, West Cliff, West Wallsend, and Wye the measured side abutment angles are significantly less than 21°.

In summary, it seems that an abutment factor of 1.5, in conjunction with an abutment angle of β = 21°, is a reasonable and generally conservative approximation of the actual tailgate load for most Australian mines. The exceptions are two collieries and one locality (containing three collieries) within the Australian database, where there is sufficient evidence to suggest that site-specific loading parameters are more applicable. These are the Central and West Wallsend Collieries, and the deepest collieries within the Southern Coalfield (South Bulli, Tower, and West Cliff Collieries). For Central Colliery, the appropriate loading parameters seem to be β = 26° and F_t = 1.6. With regard to the three Southern Coalfield collieries, the recommended loading parameters are β = 10° and F_t = 1.5, which also apply to areas associated with West Wallsend Colliery that are unaffected by the near-seam sandstone/conglomerate channels. In areas where thickening of the channel occurs, it is assessed that the abutment angle of β = 10° should be maintained, while F_t should be increased to 3.5.

Two other variables can influence the calculation of pillar stability factors: *in situ* coal strength (S₁) and the overburden density (C). A comprehensive study in the United States recently concluded that uniaxial compressive strength tests on small coal samples do not correlate with *in situ* pillar strength [Mark and Barton 1996]. That study and others in Australia and the Republic of South Africa [Salamon et al. 1996] found that using a constant seam strength works well for empirical pillar design methods. Accordingly, the *in situ* coal strength is taken to be 6.2 MPa, as used in ALPS.

In some Australian mines, there is so much coal in the overburden that the overburden density is significantly reduced below the C = 0.25 MN/m³ that is typical for sedimentary rock. Dartbrook and Kenmare Collieries have undertaken satisfactory analyses of their overburden and have determined that C = 0.22 MN/m³ and 0.23 MN/m³, respectively.

Table 2.—Supplemental stress measurements from other Australian mines

Site details	Reference	Cell type	Cell position	Remarks	N, °	F _t (Meas)
Angus Place longwall 12	Clough [1989]	CSIRO HI ..	In roof	Author indicates vertical stress increase small; may be affected by clay bands within roof strata.	5.5	—
Central longwalls 301-302	Wardle and Klenowski [1988] ..	IRAD	In seam	Satisfactory results from which to interpret main gate and tailgate loading.	26.8	1.48
Cook longwalls 5-6	Gale and Matthews [1992]	CSIRO HI ..	In roof	Satisfactory results from which to interpret main gate and tailgate loading.	38.0	1.31
Ellalong longwall 1	Wold and Pala [1986]	IRAD	In seam	Satisfactory results from which to interpret main gate loading for barrier and adjacent development pillars.	17.2	—
Ellalong longwall 1	Wold and Pala [1986]	IRAD	In seam	Satisfactory results so as to interpret main gate loading for chain pillar.	9.8	—
Kenmare longwall 1B ¹	Gordon [1998]	CSIRO HI ..	In roof	Satisfactory results from which to interpret main gate loading condition.	54.2	—
North Goonyella longwalls 3-4 . .	Nemcik and Fabjanczyk [1997] .	CSIRO HI ..	In roof	Only 2 of 4 cells functioned reliably such that a subjective assessment of the stress profiles was required.	31.5	1.2
South Bulli longwalls 504-505 . .	Mincad Systems Pty. Ltd. [1997]	IRAD and hydraulic.	In seam	Satisfactory results from which to interpret main gate and tailgate loading.	8.8	1.47
Ulan longwalls A and B	Mills [1993]	CSIRO HI ..	In roof	Satisfactory results from which to interpret main gate and tailgate loading.	35.3	1.09
West Cliff longwall 1	Skybey [1984]	IRAD	In seam	3-heading with large/small pillar combination; subjective assessment of main gate stress profile was required.	4.9	—
West Cliff longwalls 12-13	Gale and Matthews [1992]	CSIRO HI ..	In roof	3-heading with large/small pillar combination, interpretation of main gate and tailgate loading.	0.9	1.52
West Wallsend longwall 12	Stewart [1996]	Hydraulic . . .	In seam	Satisfactory results from which to interpret main gate loading condition.	5.2	
Wyee longwall 5	Seedsman and Gordon [1991] .	Geokon	In seam	Satisfactory results from which to interpret main gate loading condition.	6.2-8.8	

¹SCT operations stress monitoring exercise with HI Cells located in roof above this project's hydraulic stress cell site.

INDUSTRY REVIEW

The aim of the industry review was to construct a historical database of gate road and chain pillar performance. During the course of the project, 19 longwall mines (a cross section from the 5 major Australian coalfields) were visited. Underground inspections were conducted at each that incorporated a subjective assessment of gate road performance while documenting the relevant details in relation to panel and pillar geometry, roof and floor geology, artificial support, and in situ stress regime. Brief summary reports were then forwarded to each mine to confirm the accuracy of the recorded data. Table 3 summarizes the Australian case histories.

The U.S. database included the Secondary Support Rating (SSUP), which is described as a rough measure of the volume of wood installed per unit length of the tailgate [Mark et al. 1994]. It should be noted that 59 of the 62 cases (i.e., 95%) within the U.S. database used standing secondary support (predominantly in the form of timber cribbing) along the tailgate. In the Australian database, less than 50% (9 out of 19) mines routinely installed standing secondary support along the tailgate. In the context of this study, standing secondary support refers to timber cribbing, the Tin Can system, Big Bags, etc., and does not include tendon support (cable bolts or Flexibolts) installed within the roof. Because of the variety of secondary supports used, no Australian SSUP was attempted. Instead, a yes/no outcome is provided in table 3.

An additional geotechnical parameter included within the Australian database, but not considered during the development of ALPS in the United States, is the presence of adverse horizontal stress conditions (HORST) (see table 3). Horizontal stress can damage roadways when they are first driven, and stress concentrations associated with longwall retreat can cause further roof deterioration. The following criteria were used to categorize the operations visited on a yes/no basis:

- $30^\circ < \alpha < 135^\circ$ (see figure 7); and
- The magnitude of the major horizontal stress (F_H) is >10 MPa.

STATISTICAL ANALYSES

The same statistical technique used with the U.S. ALPS database, that of discriminant analysis, was used with the Australian data. Discriminant analysis is a regression technique that classifies observations into two (or more) populations. In the case of the ALPS data, the classified populations are tailgates with satisfactory and unsatisfactory tailgate conditions.

An initial change that was made with the Australian data was to include "borderline" tailgates with the unsatisfactory cases. This modification is consistent with the Australian underground coal industry's desire to have in place strata management plans that design against both borderline and unsatisfactory gate road conditions. It also adds to the otherwise small pool of un-

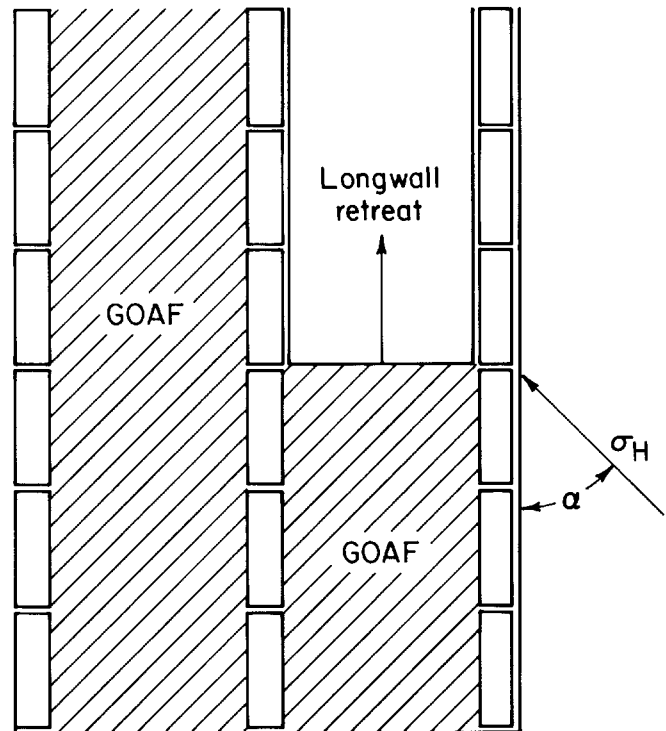

Figure 7.—The angle α used to determine the value of HORST.

Actual stress measurements were available from all except three mines in the database. The major horizontal stress is characteristically twice the vertical stress within Queensland and New South Wales coalfields. Therefore, at a depth of cover equal to 200 m, F_H is approximately 10 MPa.

It is recognized that geological structure can result in an adverse reorientation and/or magnification of the general in situ stress regime. However, there are insufficient data, within the context of this study, to include such an assessment within HORST.

satisfactory cases available for analysis.

In their analysis, Mark et al. [1994] were not able to quantify the effect of standing secondary support on tailgate conditions. However, because nearly every U.S. case used some standing support, SSUP is basically *intrinsic* to the design equation (see equation 1). Because less than 50% of Australian mines use secondary support, it seems reasonable to assume that tailgates that presently incorporate standing secondary support would become unsatisfactory if it were removed. A major modification was to include all collieries utilizing standing secondary support in the modified-unsatisfactory category of tailgate conditions.

Table 3.—Australian tailgate performance case history database

Mine	Location	Pillar width, m	Pillar length, m	Seam height, m	Depth, m	Panel width, m	CMRR	TG SF	PSUP	SSUP, Yes/No	HORST, Yes/No	Tailgate condition
Angus Place	Tailgate 21	40	95.5	3.0	340	256	35	0.84	0.84	Yes	No	S
Angus Place	Tailgate 18	40	94.5	3.0	280	206	35	1.11	0.84	Yes	No	B
Angus Place	Tailgate 22	40	95.5	3.0	360	256	35	0.76	0.84	Yes	Yes	U
Central (200)	Tailgate 202	25	94.9	2.5	165	200	55	1.33	0.27	No	No	S
Central (200)	Tailgate 203	25	94.9	2.5	190	206	55	1.05	0.27	No	No	S
Central (200)	Tailgate 204	30	94.9	2.5	210	206	55	1.26	0.27	No	No	S
Central (200)	Tailgate 205	35	94.9	2.5	225	206	55	1.50	0.27	No	No	S
Central (200)	Tailgate 206	45	94.9	2.5	240	206	55	2.14	0.27	No	Yes	S
Central (200)	Tailgate 207	45	94.9	2.5	265	206	55	1.87	0.27	No	Yes	S
Central (200)	Significant jointing		94.9	2.5			48	1.05	0.50	No	No	S
Central (300)	Tailgate 302	30	94.9	2.8	140	200	50	2.00	0.27	No	No	S
Central (300)	Tailgate 303	30	94.9	2.8	170	206	50	1.63	0.27	No	No	S
Central (300)	Tailgate 304	35	94.9	2.8	190	206	50	1.80	0.27	No	No	S
Central (300)	Tailgate 305	40	94.9	2.8	210	206	50	1.95	0.27	No	No	S
Central (300)	Tailgate 306	45	94.9	2.8	230	206	50	2.07	0.27	No	No	S
Central (300)	Tailgate 307 - 18 cut-through	45	94.9	2.8	285	206	31	1.45	0.50	No	No	U
Clarence	Tailgate 2	45	54.5	4.1	260	178	59	1.20	0.23	No	No	S
Clarence	Tailgate 3	43	54.5	4.1	260	200	59	1.10	0.23	No	No	S
Clarence	Tailgate 5	45	54.5	4.1	260	158	59	1.21	0.23	No	No	S
Clarence	Tailgate 6	45	39.5	4.1	260	200	59	1.22	0.23	No	No	S
Crinum	Tailgate 2	35	125.2	3.6	135	275	40	2.57	0.69	Yes	No	S
Dartbrook	Tailgate 2	35	94.8	3.9	250	200	51	0.86	0.42	No	No	S
Elouera	Tailgate 2 - 4 lower stress	45	12.5	3.3	350	155	40	1.02	0.85	Yes	No	S
Elouera	Tailgate 4 - 19.5 cut-through	45	125.0	3.3	350	155	40	1.00	0.85	Yes	Yes	B
Gordonstone	Tailgate 102	40	94.8	3.2	230	200	30	1.49	0.79	Yes	No	B
Gordonstone	Tailgate 202	40	94.8	3.2	230	255	35	1.49	0.79	Yes	No	S
Kenmare	Tailgate 2 - 13 cut-through	30	119.8	3.1	172	200	65	1.46	0.53	No	No	S
Kenmare	Tailgate 3 - stronger roof	25	119.8	3.1	160	200	65	1.17	0.28	No	No	S
Kenmare	Tailgate 3 - weaker roof	25	119.8	3.1	130	200	46	1.65	0.42	No	No	S
Newstan	Tailgate 10	31	97.0	3.3	180	130	39	1.39	0.66	Yes	Yes	B
North Goonyella	Tailgate 4	30	94.8	3.4	180	255	38	1.26	0.77	No	No	S
Oaky Creek	Tailgate 7 - normal roof	30	94.8	3.2	180	200	57	1.32	0.40	No	No	S
Oaky Creek	Tailgate 7 - weaker roof	30	94.8	3.2		200	48	1.32	0.57	No	No	S
South Bulli (200)	Tailgate 203	24	84.0	2.7	465	138	57	0.23	0.44	Yes	Yes	U
South Bulli (200)	Tailgate 204	31	94.0	2.7	470	183	57	0.36	0.44	Yes	Yes	U
South Bulli (200)	Tailgates 205-208, 210	40	96.0	2.7	460	183	57	0.66	0.44	Yes	Yes	B
South Bulli (200)	Tailgates 209, 211-212	38	97.0	2.7	460	183	57	0.59	0.44	Yes	Yes	B
South Bulli (300)	Tailgate 303	40	96.0	2.7	450	138	65	0.68	0.44	Yes	No	S
South Bulli (300)	Tailgates 304-305	55	74.0	2.7	450	183	65	1.15	0.44	Yes	No	S

See explanatory notes at end of table.

Table 3.—Australian tailgate performance case history database—Continued

Mine	Location	Pillar width, m	Pillar length, m	Seam height, m	Depth, m	Panel width, m	CMRR	TG SF	PSUP	SSUP, Yes/No	HORST, Yes/No	Tailgate condition
South Bulli (300)	Tailgates 308-309	38	97.0	2.7	410	185	65	0.68	0.44	Yes	No	S
Southern (600)	Tailgate 606	30	94.8	2.8	170	200	60	1.62	0.26	No	No	S
Southern (600)	Tailgates 607-608	35	94.8	2.8	190	200	60	1.79	0.26	No	No	S
Southern (700)	Tailgate 702	30	94.8	2.8	160	250	60	1.79	0.26	No	No	S
Springvale	Tailgate 402	45	95.2	2.7	325	250	35	1.22	0.63	Yes	Yes	B
Tower	Tailgate 14	45	66.0	3.2	500	203	40	0.59	1.26	No	No	S
Ulan	Tailgate 11	30	94.8	3.1	145	255	50	1.65	0.28	No	No	S
West Cliff	Tailgate 22	42	97.2	2.5	480	200	48	0.69	0.49	Yes	No	S
West Wallsend	Tailgate 13 - 4.5 cut-through	35	97.1	2.9	240	145	40	1.24	0.75	Yes	Yes	U
West Wallsend	Tailgate 13 - 7 cut-through	35	97.1	2.9	255	233	40	1.11	0.75	No	Yes	S
West Wallsend	Tailgates 14-16	32	110.1	2.9	250	145	40	0.99	0.75	Yes	Yes	U
West Wallsend	Tailgate 17 - 6 cut-through	35	110.1	3.2	250	145	40	1.08	0.75	Yes	Yes	B
Wyee	Tailgate 13	35	102.0	2.8	220	163	45	1.43	0.52	No	Yes	B
Mean		31.2	94.5	3.0	266	200	49.52	1.27	0.49			
Standard deviation		7.2	16.9	0.4	106	33	10.04	0.47	0.24			

S Satisfactory. B Borderline. U Unsatisfactory.

Two cases posed additional complications. Tower Colliery does not incorporate standing secondary support, yet its PSUP (1.26) is 3.2 standard deviations above the Australian mean. Therefore, Tower Colliery was also included within the modified-unsatisfactory tailgate category. Crinum uses standing secondary support, but it is a relatively new operation, and it seems that there has been an understandable, but nonetheless highly conservative approach to its geotechnical design. To include Crinum within the modified-unsatisfactory group would have been overly conservative, so it was excluded from the database entirely.

Therefore, the final database includes 50 case histories with 29 modified satisfactory and 21 modified-unsatisfactory cases. Numerous analyses were conducted to determine the best design equation. Ultimately, the most successful design equation relates the required TG SF to the CMRR, as shown in figure 8:

$$TG\ SF \ ' \ 2.67 \ \& \ 0.029 \ CMRR \quad (3)$$

Equation 3 correctly predicted the outcome of all except seven case histories, for a success rate of 86%. Comparing equation 3 to the U.S. design equation (equation 1), it may be seen that the TG SF is generally more conservative than the ALPS SF for weaker roof, but the TG SF decreases more rapidly than the ALPS SF as the roof becomes stronger.

Another strong relationship that was evident in the case histories was between the primary support and the roof quality. Figure 9 plots the PSUP against the CMRR, and the best-fit regression is of the following form:

$$PSUP \ ' \ 1.35 \ \& \ 0.0175 \ CMRR \quad (4a)$$

It seems that Australian mine operators have intrinsically adapted their primary support patterns to the roof conditions and operational requirements. Mark et al. [1994] reached a similar conclusion for the United States.

Upper- and lower-boundary equations (4b and 4c, respectively) relating CMRR to PSUP have also been proposed and are illustrated in figure 8:

$$PSUP_U \ ' \ 1.45 \ \& \ 0.0175 \ CMRR \quad (4b)$$

$$PSUP_L \ ' \ 1.24 \ \& \ 0.0175 \ CMRR \quad (4c)$$

Equation 4c may be applicable, for example, when the mining layout is not subject to adverse horizontal stress conditions and/or standing secondary support is planned as part of the colliery's strata management plan.

Mark et al. [1994] also found a strong correlation between the CMRR and the entry width. No such correlation was seen here.

It is interesting to note some similarities and differences between the U.S. and Australian databases. For example, overall roof quality seems to be reasonably similar in the two countries. The mean CMRR in the United States is 53.7 with a standard deviation (SD) of 13.9; this compares with an Australian mean of 49.5 and SD ' 10.0. However, the mean Australian PSUP is 0.49 (SD ' 0.23), which is approximately twice that of the U.S. database.

Studies by Mark [1998] and Mark et al. [1998a] suggest that the horizontal stress levels in the two countries are comparable. It seems that philosophical differences are more likely responsible for the different levels of primary support. Most

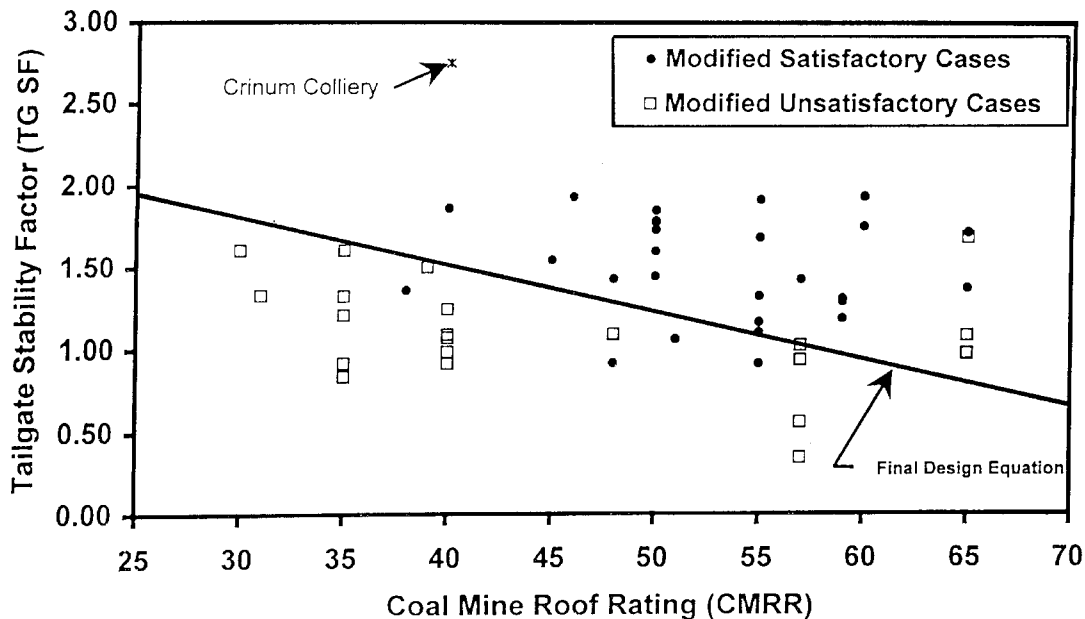

Figure 8.—The final design equation relating the CMRR to the TG SF.

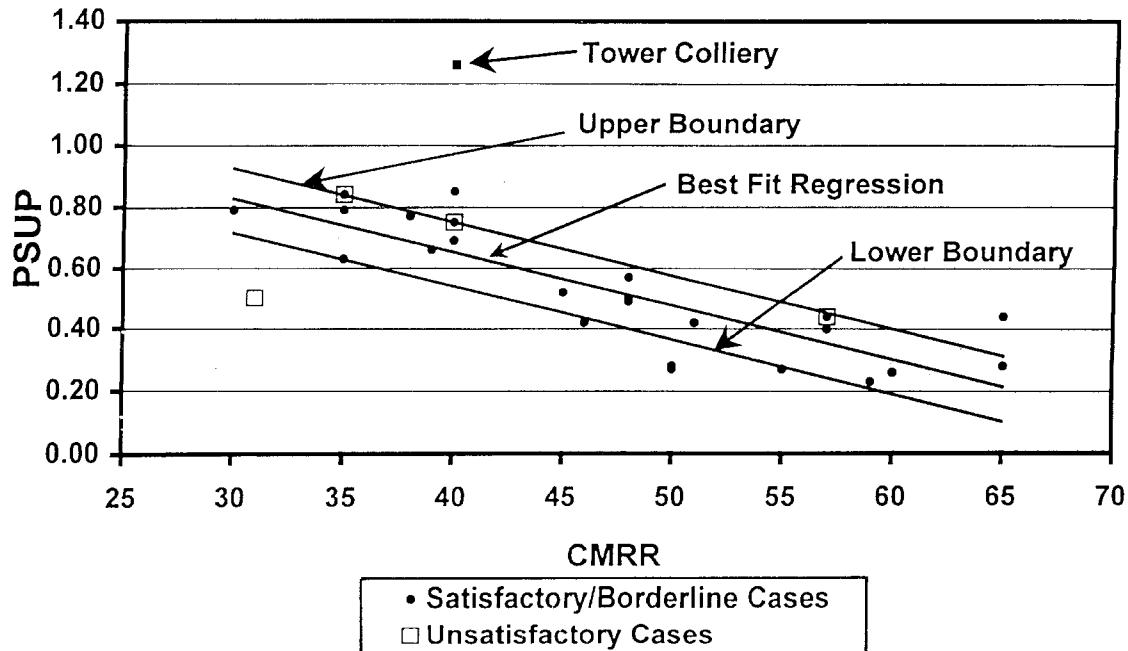

Figure 9.—Design equations for primary support based on the CMRR.

Australian coal mines have an unwritten (sometimes written) policy of no roof falls; U.S. multientry mining systems seem more tolerant of roof falls. Also, most Australian coal mines have an antipathy toward standing secondary support for reasons associated with a two-entry gate road system. It seems that the main way in which Australian operations prevent poor tailgate conditions is to install substantial primary support on development. Therefore, in Australia one would expect a strong relationship between the level of primary support and a reliable roof rating system. This is exactly what transpires, which adds to the credibility of the CMRR.

Additional statistical analyses tested whether the accuracy of ALPS could be improved by replacing the original Bieniawski formula with another pillar strength formula. Two formulas were trialed—the Mark-Bieniawski formula [Mark and Chase 1997] and Salamon's squat pillar formula [Madden 1988]. The Mark-Bieniawski formula had virtually no impact on the classification success rate. However, incorporating the squat pillar formula resulted in a significant decrease in the classification success rate. The conclusion was to remain with the original Bieniawski formula used in the "classic" ALPS.

ANALYSIS OF TAILGATE SERVICEABILITY (ALTS)

The chain pillar design methodology proposed by the project is referred to as "Analysis of Longwall Tailgate Serviceability" (ALTS). The design methodology recognizes the impact of ground support on tailgate serviceability and incorporates guidelines in relation to the installed level of primary support and the influence of standing secondary support on the design process.

A design flowchart (figure 10), Microsoft® Excel Workbook, and user manual have been developed. The spreadsheet workbook (*ALTS Protected.xls*) was formulated to facilitate the computational components of the design methodology.

The ALTS design process should only be employed in designing chain pillars that are subject to second-pass longwall extraction. If the chain pillars under consideration are not to be subject to second-pass longwall extraction, then an alternative pillar design method should be employed based on pillar stability and outer gate road serviceability requirements. The

monitored chain pillar loading behavior (conducted as a part of the project) will assist in estimating the main gate load for design purposes.

The recommended chain pillar width (rib to rib) is contingent upon an appropriate level of primary support. That level of primary support (i.e., $PSUP_L$ to $PSUP_U$) is dependent on (1) the orientation of longwall retreat in relation to the magnitude and direction of the major horizontal stress and (2) the use of standing secondary support along the length of the gate road.

The database is able to identify situations where it is likely that standing secondary support may be required. However, there are insufficient data at this stage to make numerical recommendations for the SSUP similar to those made for the TG SF and PSUP. Appropriately qualified personnel should assess the type, level, and timing of SSUP installation.

CONCLUSIONS

The following main goals of the project were achieved:

- To establish a chain pillar design methodology that has widespread application to Australian longwall operations; and
- To quantify the probable variance in the chain pillar loading environment between collieries and mining localities and to incorporate this variance within the design methodology.

In addition, the study has been able to propose definitive guidelines with regard to the installed level of primary support and to conduct a subjective analysis regarding the impact of standing secondary support on the design process. This provides the Australian coal industry with a truly integrated design methodology with regard to tailgate serviceability that has been able to address the main factors controlled by the mine operator.

The initial benefit from this project is that mine managers and strata control engineers will be able to identify where chain pillars can be reduced in size and where increases may be necessary. They can make these decisions with the confidence that a credible Australian database is the foundation for the design methodology.

This project has identified that there is an opportunity for some mines that do not currently incorporate the routine installation of secondary support along their tailgate to make significant reductions in chain pillar width. It is an operational decision whether a reduction in pillar width is more or less beneficial to production output and costs than the introduction of secondary support along the length of the tailgate. This project simply highlighted that the opportunity exists.

The chain pillar monitoring exercises conducted at collieries under deep cover or with strong roof have found that the abutment load may be overestimated by using a generic abutment angle of 21° . However, the aggressive tailgate loading behavior monitored at West Wallsend Colliery (see figure 5) provided a warning, which emphasized the need to use great caution before making any sweeping changes to a proven chain pillar design tool. Although the way in which the load manifested itself at West Wallsend was significantly different from that proposed by ALPS, the resultant tailgate load was quite similar.

REFERENCES

- Clough AJ [1989]. Monitoring of chain pillar behavior at Angus Place Colliery. Strata Control Technology Pty. Ltd. report No. SCT9005 to Newcom Collieries Pty. Ltd, November.
- Colwell MG [1998]. Chain pillar design - calibration of ALPS. Australian Coal Association Research Program, final report—ACARP project C6036.
- Frith RC, Creech M [1997]. Face width optimization in both longwall and shortwall caving environments. Australian Coal Association Research Program, final report—ACARP project C5015.
- Frith RC, Thomas RG [1995]. Roadway roof stability and its attainment through pretensioned bolting. Australian Coal Association Research Program, ACARP project report 3032.
- Gale WJ, Matthews SM [1992]. Stress control methods for optimized development and extraction methods. National Energy Research, Development and Demonstration Program, final report C1301.
- Gordon N [1998]. Geological and geotechnical aspects of the development and extraction of Aries Seam Longwalls 1A and 1B, Kenmare Colliery. Internal report for South Blackwater Coal Ltd.
- Madden BJ [1988]. Squat pillar design. *Coal Int Jan*:6-9.
- Mark C [1990]. Pillar design methods for longwall mining. Pittsburgh, PA: U.S. Department of the Interior, Bureau of Mines, IC 9247.
- Mark C [1992]. Analysis of longwall pillar stability (ALPS): an update. In: Proceedings of the Workshop on Coal Pillar Mechanics and Design. Pittsburgh, PA: U.S. Department of the Interior, Bureau of Mines, IC 9315, pp. 238-249.
- Mark C [1998]. Comparison of ground conditions and ground control practices in the United States and Australia. In: Peng SS, ed. Proceedings of the 17th International Conference on Ground Control in Mining. Morgantown, WV: University of West Virginia, pp. 63-71.
- Mark C, Barton TM [1996]. The uniaxial compressive strength of coal: should it be used to design pillars? In: Ozdemir L, Hanna K, Haramy KY, Peng S, eds. Proceedings of the 15th International Conference on Ground Control in Mining. Golden, CO: Colorado School of Mines, pp. 61-78.
- Mark C, Bieniawski ZT [1986]. An empirical method for the design of chain pillars in longwall mining. In: Proceedings of the 27th U.S. Symposium on Rock Mechanics. New York, NY: American Institute of Mining, Metallurgical, and Petroleum Engineers, pp. 415-422.
- Mark C, Chase FE [1997]. Analysis of retreat mining pillar stability (ARMPS). In: Proceedings - New Technology for Ground Control in Retreat Mining. Pittsburgh, PA: U.S. Department of Health and Human Services, Public Health Service, Centers for Disease Control and Prevention, National Institute for Occupational Safety and Health, DHHS (NIOSH) Publication No. 97-122, IC 9446, pp. 17-34.
- Mark C, Molinda GM [1996]. Rating coal mine roof strength from exploratory drill core. In: Ozdemir L, Hanna K, Haramy KY, Peng S, eds. Proceedings of the 15th International Conference on Ground Control in Mining. Golden, CO: Colorado School of Mines, pp. 415-428.
- Mark C, Chase FE, Molinda GM [1994]. Design of longwall gate entry systems using roof classification. In: New Technology for Longwall Ground Control - Proceedings: U.S. Bureau of Mines Technology Transfer Seminar. Pittsburgh, PA: U.S. Department of the Interior, Bureau of Mines, SP 01-94, pp. 5-17.
- Mark C, Mucho TP, Dolinar D [1998a]. Horizontal stress and longwall headgate ground control. *Min Eng* 50(1):61-68.
- Mark C, Su D, Heasley KA [1998b]. Recent developments in coal pillar design in the United States. In: Aziz NI, Indraratna B, eds. Proceedings of the International Conference on Geomechanics/Ground Control in Mining and Underground Construction. Wollongong, New South Wales, Australia: University of Wollongong, Vol. 2, pp. 309-324.
- Mills KW [1993]. AMIRA pillar strength measurements. Strata Control Technology Pty. Ltd. report No. ULA0290B to Ulan Coal Mines, October.
- Molinda GM, Mark C [1994]. Coal mine roof rating (CMRR): a practical rock mass classification for coal mines. Pittsburgh, PA: U.S. Department of the
- Mincad Systems Pty. Ltd. [1997]. AMIRA Project P396 - Hydraulic stressmeter, final report.

Interior, Bureau of Mines, IC 9387.

Nemcik J, Fabjanczyk M [1997]. Virgin stress and stress change measurements in maingate 3, North Goonyella underground mine. Strata Control Technology Pty. Ltd. report No. NGY1069 to White Mining Ltd., January.

Salamon MDG, Galvin J, Hocking G, Anderson I [1996]. Coal pillar strength from back-calculation. Part of a New South Wales Joint Coal Board Research Project - Strata Control for Coal Mine Design. Sydney, Australia: University of New South Wales, School of Mines.

Seedsman RW, Gordon N [1991]. Methods to optimise mining operations affected by weak claystone materials. NERDCC end-of-grant report - project No. 1336.

Skybey G [1984]. Evaluation of the stability of longwall chain pillars at West Cliff Colliery. Australian Coal Association Research Program, published report 84-19.

Stewart A [1996]. Chain pillar monitoring - West Wallsend Colliery, LW 12 cut-through 11. Coffey Partners International Pty. Ltd. report No. Z267/4-AB to Oceanic Coal Australia Ltd., November.

Wardle LJ, Klenowski G [1988]. Rational longwall layout design based on numerical stress analysis. In: Proceedings of AusIMM - 21st Century Higher Production Coal Mining Systems—Their Implications, pp. 115-121.

Whittaker B, Frith RC [1987]. Aspects of chain pillar design in relation to longwall mining. Proceedings of the Sixth International Conference on Ground Control in Mining. Morgantown, WV: West Virginia University, pp. 172-182.

Wilson AH [1981]. Stress and stability in coal ribsides and pillars. In: Peng SS, ed. Proceedings of the First International Conference on Ground Control in Mining. Morgantown, WV: West Virginia University, pp. 1-12.

Wold MB, Pala J [1986]. Three-dimensional stress changes in pillars during longwall retreat at Ellalong Colliery. Commonwealth Scientific and Industrial Research Organisation (CSIRO) Australia, Division of Geomechanics, coal mining report No. 65.