

Public Health Reports

Vol. 60 • MAY 25, 1945 • No. 21

SERIAL PASSAGE OF *PLASMODIUM GALLINACEUM* IN CHICK EMBRYOS¹

By VICTOR H. HAAS, *Senior Surgeon, United States Public Health Service*, HARRY A. FELDMAN, *Major, M. C., Army of the United States*, and FRANCES MOORE EWING, *Medical Technician, United States Public Health Service*

This report describes a method by which *Plasmodium gallinaceum* has been established in chick embryos, and presents some of the observations made during passage.

Parasites.—The parasites employed in these studies originated from our passage strain of *P. gallinaceum*,² which is maintained by intravenous inoculation of chicks from 1 to 4 days old. For some months prior to the adoption of the method of embryo inoculation to be described in this paper, we had maintained a substrain by inoculating parasitized blood into the bodies of 11-day-old chick embryos. Although we accomplished nine serial passages from embryo to embryo in this fashion the results were so unreliable that the method was finally abandoned, but the parasites used to initiate the serial passages to be described below came from the heart blood of a 1-day-old chick which had hatched out from an embryo representing the ninth serial passage by our original method of inoculation.

Embryos.—Fertile chicken eggs are purchased from a local dealer, without specification as to breed or strain. These eggs are incubated for 10 to 13 days at 99° to 100° F., prior to inoculation. From the standpoints of ease of inoculation, ability to survive operation, and allowance for sufficient time for development of the infection before hatching, we prefer 11- or 12-day-old embryos.

Technique of inoculation.—The method of inoculating chick embryos intravenously described in detail by Eichhorn (1) is the one now employed by us. The only alterations which we have introduced are:

¹ From the Division of Infectious Diseases, National Institute of Health, U. S. Public Health Service, and the Medical Corps, Army of the United States.

² The strain of *Plasmodium gallinaceum* employed was received in the form of citrated infected chick blood from Dr. G. E. Coatsney of the National Institute of Health and is stated by him to be strain 8A, as designated by the Committee on Terminology of Avian Malaria of the American Society of Parasitologists.

(a) A triangular, instead of a rectangular opening in the eggshell is used. The triangle is so cut that the proximal part of the vein to be used lies in the apex, while the distal portion bisects the base, i. e., the triangle "points" in the direction of the flow of blood in the vein.

(b) Melted paraffin is used for sealing the entire triangle of exposed shell membrane.

The quantity of material routinely inoculated into each embryo is 0.1 cc.

Method of harvesting and preparing inoculum.—The inoculum consists of parasitized blood from previously infected chick embryos. Our passage technique is carried out as follows:

Embryos inoculated by the intravenous method are allowed to incubate for 5 or 6 days. Candling is carried out daily so that dead embryos may be discarded. On the fifth or sixth day after inoculation a window approximately 1 cm. square is cut out of each of several eggs at a site distant from the inoculation triangle. The shell is removed with its adherent membrane by coating the cut-out square with melted paraffin and then removing the shell after the paraffin has hardened. The exposed chorioallantoic membrane is then abraded gently with a sterile knife. A drop of the blood which oozes out is picked up on a slide and used to make an ordinary blood film. The window in the eggshell is covered with a sterile cover slip set in paraffin, and the egg returned to the incubator.

The blood films are stained with Giemsa stain, and the parasitized cells are counted in those preparations found to be positive.³

Only those embryos with more than 1,000 parasitized cells per 10,000 erythrocytes are used for transferring the passage strain. Those selected for passage are harvested by removing the embryo through an opening in the eggshell. A convenient presenting part is grasped with a sterile forceps, the umbilical vein severed, and the embryo allowed to exsanguinate (usually yielding about 1 cc. of blood) into a small sterile glass vessel containing anticoagulant. The requisite type and quantity of anticoagulant are calculated as follows:

Parasite count on embryo	Type and quantity of anticoagulant
1,000-2,500.....	A drop (approximately 0.01 cc.) of heparin.
Over 2,500-4,000.....	1 cc. sodium citrate solution (2-percent).
Over 4,000-7,000.....	2 cc. sodium citrate solution (2-percent).
Over 7,000.....	3 cc. sodium citrate solution (2-percent).

The blood-anticoagulant mixture is now made up into four lots, according to the following system: ⁴

³ Parasite counts were determined by counting the number of parasitized cells per 500 erythrocytes and multiplying this count by 20 to give an approximation of parasitized cells per 10,000 erythrocytes. The method was based on a personal communication from Dr. Coatney. No account was taken of multiple infections of erythrocytes.

⁴ This method of using several dilutions has worked satisfactorily for us and is used because we find that parasite peaks tend to develop a little more slowly in the embryos inoculated with higher dilutions, and therefore we feel more certain of obtaining embryos with counts of the magnitude desired over a period of several days instead of all at once. This is only a tendency, however, and is not particularly marked in the dilutions we use. It does not appear that the time of death is noticeably influenced by these dilutions. For more exacting studies than those required in simply establishing the practicability of the method, it is probable that higher serial dilutions would enable titrations to be run. Such studies are now in progress.

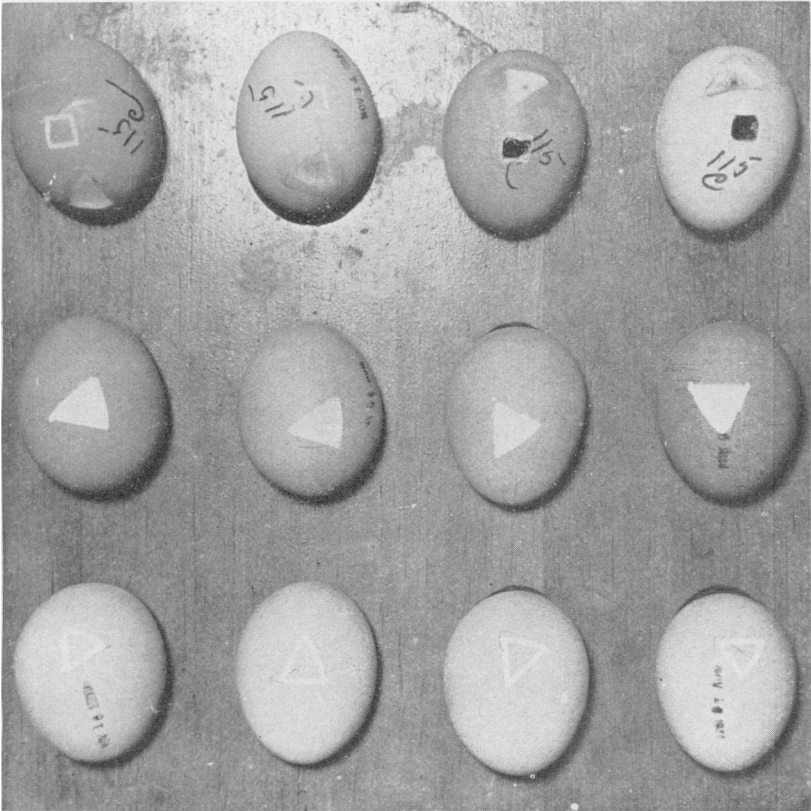

FIGURE 1.—Eggs prepared for inoculation and blood counts. *Bottom row:* Triangular cut through shell. Pencil arrow over course of blood vessel. *Middle row:* Triangular area of shell membrane exposed. When a drop of petrolatum is placed on this area the underlying blood vessel is visualized. *Top row:* Eggs previously inoculated, now being prepared for blood count. Two eggs on left show square areas of shell outlined by cutting with dental carbon disc. Two eggs on right show shell and underlying square of shell membrane removed, with chorioallantoic membrane (dark area) exposed. Old triangular areas where inoculation was made several days previously now shown covered with paraffin. (Photograph by Senior Sanitary Engineer H. A. Johnson.)

Lot A. Blood from the embryo plus anticoagulant as indicated in the table given above, based on parasite count of embryo selected.

Lot B. Mixture from lot A plus an equal quantity of sterile sodium citrate (2-percent solution).

Lot C. Mixture from lot B plus an equal quantity of sterile sodium citrate solution.

Lot D. Mixture from lot C plus an equal quantity of sterile sodium citrate solution.

If embryos with relatively low parasite counts are used, we generally sacrifice two or three, bleed each into the calculated quantity of anticoagulant, and pool the mixtures to make up lot A. A single embryo will ordinarily furnish sufficient material for transfer, since parasite counts are usually high; thus a relatively large volume of anticoagulant goes into the original dilution comprising lot A.

For routine passage, we usually employ four dozen embryos of suitable age (11 to 13 days), inoculating one dozen from each of the four dilution lots. The number of embryos used is varied occasionally as the situation demands.

Development of infection in inoculated embryos.—Our passage strain is now in its fourteenth passage generation, but the material to be analyzed below will include only the embryos used in the first 12 passages (since those of the 2 latest passages have not as yet been fully disposed of), plus a number of additional lots carried along at the same time for study.

There were 751 embryos inoculated by this technique. Of this total, 41 were sacrificed for transfer or examination. The fate of the 710 inoculated embryos in which the disease was permitted to run its course was as follows:

Period after inoculation	Number of embryos dying	Period after inoculation	Number of embryos dying
First 48 hours.....	281	Tenth day.....	53
Third day.....	10	After tenth day.....	28
Fourth day.....	10		
Fifth day.....	13	Total.....	691
Sixth day.....	36	Number of embryos survived and hatched.....	19
Seventh day.....	46		
Eighth day.....	69	Total inoculated embryos.....	710
Ninth day.....	145		

It must be assumed that the 281 embryos dying within the first 48 hours succumbed to the trauma of inoculation, representing an over-all loss of 39 percent due to the difficulties inherent in the method. This 48-hour mortality varies somewhat from lot to lot, the lowest having been 6 deaths in a lot of 41 embryos (15 percent), and the highest 16 in a lot of 20 (80 percent). Controls were run by inoculating 2 lots of 24 embryos each with normal, uninfected chick-embryo blood, heparinized, and made up into the same type of serial dilutions as those described above; the 48-hour mortality in these 2 groups was

6 embryos (25 percent) in each lot. Another lot of 54 embryos was inoculated with parasitized blood having a count of 8,000, but the parasites had been killed just before inoculation by heating for 1 hour at 57.5° C. In this group the 48-hour mortality was 13 embryos (24 percent).

Our over-all mortality rate compares favorably with the 30 percent operative mortality reported by Eichhorn (1) for the same method of inoculation.

It is clear that after the initial 48 hours deaths are few until the sixth day after inoculation. From this time on, however, the effects of the developing infection in the embryo are reflected in the rapidly rising mortality, with the greatest number of deaths occurring on the ninth day.

The evolution of the infection is also apparent in the parasite counts:⁵

Day after inoculation	Number of embryos on which counts made	Range of parasite counts	Mean of counts (approximate)
4	6	10-40	20
5	19	10-8,000	2,800
6	19	250-9,000	5,400
7	3	8,500-9,000	8,800
8	2	8,000-9,000	8,500
9	1	8,000	8,000

The mortality data indicate that 19 embryos, out of the 710 in which the infection was allowed to develop, survived and hatched out. The fate of these chicks was as follows:

(a) Eleven failed to develop parasitemia during the period of observation; 9 of these died, at 1, 3, 5, 6, 7, 8, 8, 10, and 15 days after hatching. Autopsies on 6 of these showed no evidence of malaria; one autopsy, on the chick dying on the sixth day, showed liver and spleen discolored with pigment, a phenomenon which will be discussed below, and which we regard as positive evidence of infection; on the remaining 2 no autopsies were done, although 4 blood examinations on one and 8 on another had shown no parasitemia. It is presumed that these chicks, except the pigmented one, died in infancy of its attendant feebleness, as we do not make any special effort to give them particular care. The other 2 chicks have survived over 6 weeks and are still alive, with no evidence of infection.

(b) Eight developed parasitemia during the period of observation; 7 died, 1, 1, 1, 2, 2, 5, and 9 days after hatching. Six of these had parasitemia at the time of the first blood examination, either on the day of hatching or on the day after; 1 did not develop detectable

⁵ Negative counts are not included in the summary as some of these represent embryos in which infection failed to "take," while in other cases it was not possible to determine whether parasitemia would have appeared later, since embryos often die from injury sustained when the count is made.

parasitemia until the third day after hatching, and this particular chick was the one which died on the ninth day. Peak parasite counts were from 5,000 to 9,900, with a mean of 8,300. The remaining chick in this group which developed parasitemia had a parasite count of 9,800 at time of hatching and was killed for other studies.

It may be noted, for comparison, that 36 embryos out of the lot of 54 inoculated with heat-killed parasites were allowed to develop without interruption (18 were killed for examination); of the 23 which survived the first 48 hours after inoculation, 16 hatched out as live and apparently healthy chicks. This hatching rate—16 out of 23—is in marked contrast to the 19 out of 429 which was observed in the case of embryos inoculated with living parasites, i. e., 710 embryos less the 281 which failed to survive the first 48 hours.

Pigmentation of infected embryos.—Embryos inoculated by the method described tend to develop a green discoloration which is sometimes seen while candling the living embryo. Eggs opened at advanced stages of the infection show this green color throughout the embryonic membranes, the amniotic fluid, the yolk, and the livers and spleens of the embryos themselves.

This discoloration has been noted as early as the fourth day, although it does not become heavy until the sixth day or later.

An analysis of 236 records selected at random from those in which presence or absence of pigmentation was recorded shows the following:

Day after inoculation on which examination was made	Embryos examined			
	Embryos which died		Embryos which were killed	
	Number examined	Number pigmented	Number examined	Number pigmented
1.....	None.....	None.....
2.....	9.....	0.....	None.....
3.....	None.....	None.....
4.....	1.....	1.....	None.....
5.....	6.....	5.....	None.....
6.....	9.....	8.....	4.....	4.....
7.....	29.....	28.....	4.....	4.....
8.....	56.....	55.....	3.....	2.....
9.....	91.....	91.....	None.....
10.....	31.....	31.....	None.....
Over 10.....	12.....	10.....	1.....	1.....
Total.....	244.....	229.....	12.....	11.....

A "control series" of 48 embryos inoculated with the blood of a normal, uninfected, 15-day-old embryo showed no pigment nor any suggestion of greenish discoloration in 36 embryos killed and examined on the sixth day. Also, a lot of 54 embryos inoculated with parasitized blood after the parasites had been heat-killed showed no pigment in 13 embryos killed on the seventh day, and none in 5 embryos killed on the eighth day.

The presence of the green discoloration provides a rapid and easy method of diagnosis of malaria infection and obviates the necessity for making great numbers of blood films. Where confirmation is desired, blood films may be made on a check sample of embryos.

SUMMARY

Plasmodium gallinaceum has been carried through 14 serial passages by inoculating 10- to 13-day-old chick embryos intravenously with parasitized blood.

The infection produced in chick embryos by this method is highly fatal, with the majority of deaths from malaria occurring on the ninth day.

In our hands, there has been an over-all mortality rate of 39 percent within the first 48 hours after inoculation, apparently due to the difficulties inherent in the method. Nevertheless, there are enough embryos surviving this early critical period to make the method a practical and reliable one for carrying this parasite in the chick embryo.

The presence of a green color in infected embryonic membranes, fluids, and in the liver and spleen of the embryo itself permits a ready and easy diagnosis of the presence of malaria infection, and obviates the necessity for examining numerous blood films for parasites.

REFERENCES

- (1) Eichhorn, E. A.: Technique for intravenous inoculation of chick embryos. *Science*, **92**: 245-246 (Sept. 13, 1940).

A UNIVERSAL TYPE CONCRETE SLAB FOR PRECAST DITCH LININGS¹

By WILEY VERNON PARKER, *Engineering Aide*, and H. A. JOHNSON, *Senior Sanitary Engineer, United States Public Health Service*

A large quantity of durable ditch lining has been installed in southern communities during the past 10 years as a permanent mosquito and malaria control measure.

The linings installed have been mainly of concrete and can be divided into two general types, the cast-in-place monolithic lining and the precast lining. The monolithic linings can be varied at the site as may seem necessary to fit the ditch contour. The precast lining is usually made in the form of slabs in a sheltered place during inclement weather and often under conditions where the form of the ditch to be lined cannot be anticipated. These facts alone have resulted in many attempts to design a precast slab that could fit into any type of ditch and at any place in the ditch lining.

¹ From Malaria Investigations, National Institute of Health, Memphis, Tenn.

This article describes a type of concrete slab that can be used to line the majority of malaria control ditches, and the method of applying the slab to form a lining. The slab has been designed with three objects in view:

1. To produce a universal slab that will fit into the usual plan of linings and thereby necessitate the handling of only one shape slab anywhere in a proposed ditch lining.

2. To make the universal slabs of such size and shape that one man can handle them conveniently and without undue exertion.

3. To form a joint surface on the slab that will discourage the penetration of vegetation by creating an irregular and angular course through the joint.

LININGS POSSIBLE WITH
THE UNIVERSAL SLAB



FIG. 1

FIG. 2

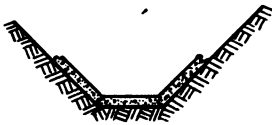

FIG. 3



FIG. 4



FIG. 5

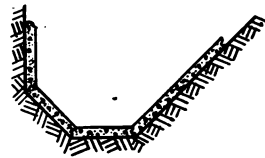

FIG. 6



FIG. 7

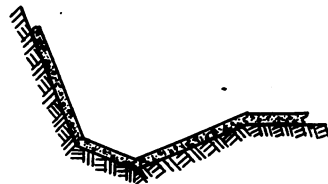

FIG. 8

The accompanying drawing (fig. 10) shows the general design of slab developed to fulfill the above requirements. It is 12 inches wide, 24 inches long, 2 inches thick, and weighs about 55 pounds.

The main features of the slab which accomplish the above-mentioned purposes are the joint surfaces. All four joint surfaces are of the tongue-and-groove type. Reference to figures 1 to 10 will show that the joint surfaces on the two long sides of the slab are tongue on one side and groove on the other. These tongue-and-groove surfaces are formed on an edge which is at an angle of $67\frac{1}{2}^\circ$ with the slab surfaces as shown in figure 11. The end joint surfaces are similarly constructed (tongue and groove on opposite ends) except that the tongues and grooves are formed on an edge that is at a 90° angle with the slab surface. This construction must be provided for in the forms.

With the long edges constructed as described, it is possible to lay two or more slabs together, forming a closed joint lengthwise of the slab. Depending on which side of the slab is uppermost, either a 135° angle or a 180° angle between the slabs can be made as shown in figures 11 and 12, and the joint remains a closed one.

After experimenting with many different mixtures of cement, sand, and gravel, we feel that a 1:2:4 mix using a $\frac{3}{8}$ -inch graded gravel is economically most suitable for this particular slab. The materials are mixed with 6 gallons of water per sack of cement to give a "slush mix." A very high strength of concrete is not a prime factor in ditch work, and the above mix gives a homogenous slab that will withstand handling with almost no breakage.

The forms for casting the slab can be constructed singly or in quantity. We prefer from a production standpoint to make multiple forms, consisting of a pallet or platform long enough to hold five slabs (about 14 feet), with a break between slabs, and upon which the side rails and cross members are arranged with suitable wedges to hold the forms securely in place. These forms are shown in figures 9 and 13. Details of the horizontal joint are shown in figures 11 and 12.

Before casting the slabs, the forms are closed, wedged, and oiled. The concrete is mixed either by hand or in a mechanical mixer. With a small $3\frac{1}{2}$ -cubic-foot mixer one man measures and places the materials in the mixer, including the exact proportional amount of water, while another man distributes the mixed concrete, usually with a wheelbarrow, to the forms, which are arranged in a semicircular location around the mixer or mixing board. The general arrangements for convenience of the work are shown in figure 14. Still another man tamps the concrete in the forms and smooths off the top of the surface with a wooden trowel as shown in figure 15. It is best first to use a straightedge to knock off the top of the concrete in order to give it a uniform surface.



FIG. 9

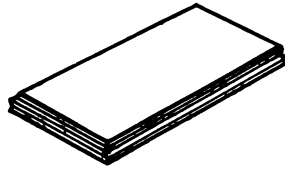

FIG. 10

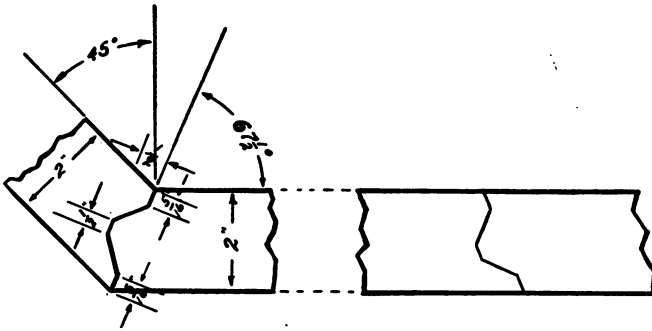

FIG. 11

FIG. 12

DETAIL OF JOINT

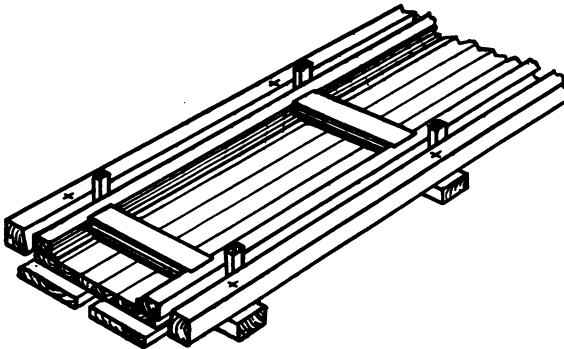

FIG. 13

The forms are left in place for approximately 24 hours; then the side rails may be removed, the slabs and partition form members remaining undisturbed on the pallet or platform for a minimum time of 48 hours.

After the forms are constructed 3 men can assemble the forms and with the aid of a cement mixer can cast 200 slabs per day at a labor cost of 16 square feet per man-hour.

By turning the slabs over as may be necessary to make well-fitting joints, any of the shapes of ditch sections shown in figures 1 to 8, inclusive, can be formed.

In the installation the ditch is shaped and graded in the usual way to accommodate the type of lining determined upon for that particular installation. If the ditch is wet at the time, it is of course desirable to dewater it and dry it sufficiently to lay the lining in a workmanlike manner and with the assurance of a suitable supporting ground surface.

FIG. 14

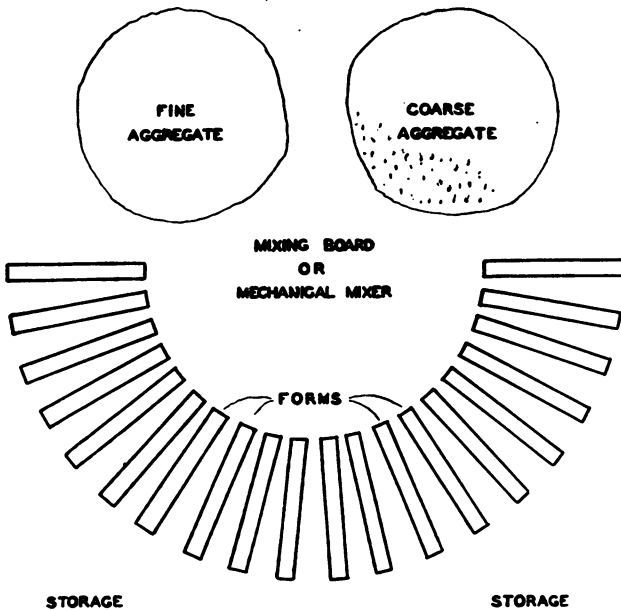

The tongue-and-groove joints should be placed in such manner as to interlock perfectly, and each horizontal layer should break joints with the adjacent layer for resistance against settling.

It should be noted that this design of lining, as is the fact with all precast lining, is primarily suited to straight runs. Where sharp curves are encountered it will be necessary to leave the joints open on the outer side of the curve. Such open spaces should be filled in with a suitable mixture of grout. We recommend a mixture of one part cement, two parts sand, and two parts $\frac{3}{8}$ -inch graded gravel.

Our experience in installing these slabs has demonstrated that it is simpler to prepare and install a flat-bottom section than it is to use



FIGURE 15.—Arrangement of slab-casting yard, showing assembled form and details of casting the slab.



FIGURE 16.—Laying a 3-slab-wide V-bottom ditch lining in a previously shaped ditch.

the V-bottom section. Correctly laid flat-bottom cement-lined ditches do not encourage mosquito breeding, as small pools either dry up or become too warm to permit propagation of mosquitoes.

In the usual places where a durable ditch lining for malaria control is placed, one horizontal flat slab, with one side slab on each side laid at an angle of 45° with the horizontal will suffice. The cost of excavation and shaping the ditch preparatory to installing this type of lining will vary greatly, of course, according to conditions found in the various locations. Therefore, it is not possible to give costs of preparing the ditch surface for installing the lining. However, once the ditch is in shape to receive the lining, and the material has been distributed on the ditch bank, three men can lay an average of 300 lineal feet of lining, three slabs wide, per day, or an average of 37 square feet of the three-slab lining per man-hour.

Upwards of 2,000 lineal feet of this type of ditch lining have now been installed in various sizes of ditches, and it is felt that the practicability of the design has been fully established.

These experimental installations will be observed over a period of years to determine the effects of climates and freezes. A photograph is included (fig. 16) showing installations of this universal lining in malaria control ditches.

SUMMARY

A universal type of precast slab for ditch linings has been developed that is simple to construct, capable of being handled by one man, flexible as to the over-all shape of the ditch, and one that delays the penetration of vegetation through the joints.

It is not practicable to give the cost in dollars of this type of lining installed. It can, however, be stated that, under normal production, eight slabs, or 16 square feet, per man-hour will be cast. Also, 12 to 14 lineal feet of lining per man-hour should be laid where the lining is three slabs wide.

The cost of materials for the slabs has averaged 8 cents per square foot, or 16 cents per slab, when cement costs 80 cents per sack, sand \$1.40 per cubic yard, and $\frac{3}{8}$ -inch graded gravel \$1.40 per cubic yard.

THE GROWTH OF *PASTEURELLA TULARENSIS* IN THE YOLK SAC OF DEVELOPING CHICK EMBRYO¹

By CARL L. LARSON, *Passed Assistant Surgeon, United States Public Health Service*

Ransmeier (1) demonstrated that *Pasteurella tularensis* grew well on chick embryos when measured or unmeasured amounts of organisms were placed on the chorioallantoic membrane and that deaths among the embryos due to specific infection usually occurred in the period from 72 to 120 hours after inoculation of infective material. The

technique utilizing the yolk sac of the developing chick embryo for the cultivation of rickettsiae was described by Cox (2). The use of this technique has been so successful in studies of rickettsiae and the psittacosis-lymphogranuloma venereum group of viruses that it seemed advisable to test the ability of *P. tularensis* to survive and grow in developing chick embryos when this technique was employed.

MATERIALS AND METHODS

Fertile hen's eggs which had been incubated at 37° C. for 7 days were injected with infective material by the Cox method, using 0.3 cc. as an inoculum. The eggs were replaced in an incubator at 37° C. and were candled daily to determine the time of death.

The inoculum for serial passage in eggs consisted of 0.1 percent yolk sac suspension in 0.85 percent salt solution. The yolk sacs were removed from the eggs, drained of excess yolk, suspended in sufficient salt solution to make a 10 percent yolk sac preparation by weight, and ground in a Waring blender. Further serial tenfold dilutions were made from this 10⁻¹ suspension in salt solution.

Tests for infectivity of embryonic tissues were carried out. Yolk and chorioallantoic fluids were diluted with salt solution as were yolk sac, chorioallantoic membrane, and embryo proper. The tissues had been previously washed with salt solution, drained, weighed, and ground in a Waring blender with sufficient salt solution to make a 10-percent suspension by weight. Serial tenfold dilutions were then made in salt solution, using a separate pipette for each dilution and 0.3 cc. of the various dilutions were injected intraperitoneally into groups of mice or into the yolk sac of chick embryos.

The relative numbers of organisms present in the yolk sacs were determined by microscopic examination of stained smear preparations. Wayson's stain, as recommended by Brown and Nunemaker (3), was employed. Only those yolk sacs containing large numbers of organisms were selected for further study.

The strains of *P. tularensis* studied were obtained from the sputum of two individuals suffering from tularemia. One person (R. H. P.) had primary pulmonary involvement while the other (J. J.) had the typhoidal type of disease. Both strains of organisms were highly virulent for laboratory animals.

RESULTS

Both strains of organisms have been successfully cultured in the yolk sac of chick embryos. Strain R. H. P. was carried through 6 passages, while strain J. J. was carried through 13 passages in eggs before this phase of the study was dropped. No loss of virulence for

¹ From the Division of Infectious Diseases, National Institute of Health.

white mice could be detected in the organisms after these passages in eggs. The infectivity of the suspensions of yolk sacs from embryos in the various stages of the passage experiments were tested by the inoculation of 0.3 cc. of serial tenfold dilutions intraperitoneally into mice. The yolk sacs of eggs infected with strain J. J. were tested in mice following the first, second, third, fourth, sixth, seventh, eleventh, and thirteenth egg passages. The highest titres obtained in all instances were 10^{-8} except in the second passage where an infective titre of 10^{-9} was observed. Transfers from egg to egg were usually made on the second or third day when the embryos were either sluggish or dead.

The various tissues and fluids of chick embryos were titrated in mice in order to determine the relative concentration of organisms. In all instances the yolk sac preparations had as high or higher titres than the other materials examined although all tissues and fluids tested were found to contain infective organisms. The infective titres obtained approximate those usually encountered with tissues of mice or guinea pigs dying of tularemia. The results obtained are shown in table 1. It is of interest that in one instance where identical amounts of the same material were inoculated into the yolk sac of one group of embryos and into the allantoic sac of another group, the allantoic fluid and yolk sac of each group contained approximately the same concentration of organisms per unit volume.

Attempts were made to determine whether or not a toxic substance was present in suspensions made from tissues or fluids obtained from infected eggs. Intravenous injection of 0.25 or 0.5 cc. of serial twofold dilutions of infective yolk sac or allantoic fluid failed to produce death or illness in mice within a period of 18 hours, but illness and death

TABLE 1.—*The distribution of P. tularensis in various fluids and tissues of chicken embryos infected with this organism as determined by 50-percent lethal end point in mice*

Method of inoculation	Material examined	Strain of organism used to infect embryo	Number of passages in egg embryo	50-percent lethal end point for mice
Yolk sac.....	Yolk sac.....	J. J.....	1	2.4×10^{-8}
Do.....	CAF ¹	J. J.....	1	5.9×10^{-8}
Allantoic sac.....	Yolk sac.....	J. J.....	1	4.2×10^{-7}
Do.....	CAF.....	J. J.....	1	3.2×10^{-7}
Do.....	Embryo.....	J. J.....	1	3.2×10^{-8}
Yolk sac.....	Yolk sac.....	J. J.....	11	5.7×10^{-9}
Do.....	CAF.....	J. J.....	11	4.0×10^{-5}
Do.....	CAM ²	J. J.....	11	5.6×10^{-8}
Do.....	Embryo.....	J. J.....	11	4.0×10^{-7}
Yolk sac.....	Yolk sac.....	R. H. P.....	5	4.0×10^{-9}
Do.....	CAF.....	R. H. P.....	5	5.6×10^{-8}
Do.....	CAM.....	R. H. P.....	5	4.0×10^{-8}
Do.....	Embryo.....	R. H. P.....	5	4.0×10^{-8}
Do.....	Yolk.....	R. H. P.....	5	1.8×10^{-9}

¹ CAF—Chorioallantoic fluid.

² CAM—Chorioallantoic membrane.

occurred at subsequent intervals corresponding to the times at which mice inoculated intraperitoneally with identical doses of the same material succumbed to acute infection.

All deaths observed were apparently due to infection rather than to any toxin liberated during proliferation in the embryo.

The relative susceptibility of mice and chick embryos to infection with *P. tularensis* was tested, using strain R. H. P. The inocula consisted either of serial tenfold dilutions of a 24-hour culture on glucose cystine blood agar suspended in salt solution and made up to a density of T-500 or of yolk sac suspensions of the fourth or fifth passage of this strain in chick embryos. Doses of 0.3 cc. of the various dilutions of the respective suspensions were given into the yolk sac of five or six embryos and into the peritoneal cavity of a similar number of mice. The results are presented in table 2. They show that chick embryos are approximately as susceptible to infection with *P. tularensis* as are mice, a finding which is in accord with the results obtained by Ransmeier who used the chorioallantoic route of inoculation for the chick embryos. Death of the embryo occurred from 2 to 7 days follow-

TABLE 2.—The relative sensitivity of white Swiss mice and chicken embryos for *P. tularensis* as determined by intraperitoneal inoculation of the former and inoculation into the yolk sac of the latter with serial tenfold dilutions of infective yolk sac suspensions or of a T-500 suspension of a 24-hour-old culture on glucose cystine blood agar

Strain of organism used	Number of passages in yolk sac of chicken embryos	50 percent lethal end point for mice	50 percent lethal end point for chicken embryos
R. H. P.-----	0 (culture)-----	6.8×10^{-9}	6.8×10^{-9}
R. H. P.-----	4-----	1.5×10^{-8}	3.0×10^{-7}
R. H. P.-----	5-----	4.0×10^{-9}	3.2×10^{-10}

ing inoculation depending upon the number of organisms introduced into the yolk sac. Almost all embryos receiving 10^{-1} to 10^{-4} dilutions of infective materials were dead on the second or third day after inoculation.

Organisms were readily observed in tissues taken from chick embryos, but were observed best in allantoic fluid, the chorioallantoic membrane, and the yolk sac. Stained preparations were made by making impression smears of tissues, allowing them to dry in air, flaming, flooding with Wayson's stain for 20 seconds, washing quickly in tap water, and drying. Extracellular and intracellular bacteria were observed. They stain a deep purple color and are surrounded by a clear area. This is in contrast to the staining qualities of *P. tularensis* taken from cultures on artificial media which stain red and are not surrounded by a clear area.

DISCUSSION

P. tularensis grows readily when introduced into the yolk sac and the susceptibility of chick embryos when infected by this route is about the same as that for mice and the concentration of organisms attained is great, approximating that usually attained in tissues of mice infected with this agent. The technique of inoculation is simple and the yield of organisms relatively great. It may be possible to utilize this medium for the growth of organisms for certain purposes as the production of antigenic material or to maintain organisms in a virulent state.

SUMMARY

P. tularensis grows readily on chick embryos when introduced into the yolk sac.

Chick embryos are as susceptible as mice to infection with *P. tularensis*.

The concentration of organisms in the tissues and fluids of infected chick embryos approaches that obtained in infected mice.

REFERENCES

- (1) Ransmeier, J. C.: The reaction of the chick embryo to virulent and non-virulent strains of *Bact. tularensis*. *J. Inf. Dis.*, **72**: 86 (1943).
- (2) Cox, Herald, R.: Use of yolk sac of developing chick embryo as medium for growing rickettsiae of Rocky Mountain spotted fever and typhus groups. *Pub. Health Rep.*, **53**: 2241 (1938).
- (3) Brown, T. McP., and Nunemaker, J. C.: Rat-bite fever. *Bull. Johns Hopkins Hosp.*, **70**: 201 (1942).

DEATHS DURING WEEK ENDED APRIL 28, 1945

[From the Weekly Mortality Index, issued by the Bureau of the Census, Department of Commerce]

	Week ended Apr. 28, 1945	Corresponding week, 1944
Data for 93 large cities of the United States:		
Total deaths.....	9, 103	9, 322
Average for 3 prior years.....	9, 375	-----
Total deaths, first 17 weeks of year.....	162, 730	169, 762
Deaths under 1 year of age.....	571	609
Average for 3 prior years.....	630	-----
Deaths under 1 year of age, first 17 weeks of year.....	10, 761	10, 737
Data from industrial insurance companies :		
Policies in force.....	67, 249, 729	66, 399, 327
Number of death claims.....	16, 240	12, 498
Death claims per 1,000 policies in force, annual rate.....	12.6	9.8
Death claims per 1,000 policies, first 17 weeks of year, annual rate.....	11.1	11.1

PREVALENCE OF DISEASE

No health department, State or local, can effectively prevent or control disease without knowledge of when, where, and under what conditions cases are occurring

UNITED STATES

REPORTS FROM STATES FOR WEEK ENDED MAY 5, 1945

Summary

Of the total of 28 cases of poliomyelitis, the same as reported for last week, only 5 States reported more than 1 case—Texas 6, Louisiana and California 3 each, and New York and Alabama 2 each. For the corresponding week last year 14 cases were reported, that figure being also the 5-year (1940-44) median. The total to date is 609 cases, as compared with 389 for the corresponding 18-week period last year and a 5-year median of 414.

Following last week's slight increase, the decline in the incidence of meningococcus meningitis was resumed. A total of 154 cases was reported, as compared with 202 last week, 382 and 605 for the corresponding weeks of 1944 and 1943, and a 5-year median of 89. The largest numbers reported currently were 15 cases each in New York, Illinois, and California, 13 in Pennsylvania, and 9 in Texas. The cumulative total is 4,163, as compared with 9,465 and 8,817 for the corresponding periods of last year and 1943, and a 5-year median of 1,400.

Of the total of 19 cases of smallpox, as compared with 3 last week and a 5-year median of 18, 14 occurred in Indiana.

A total to date of 22 cases of Rocky Mountain spotted fever, as compared with 15 for the same period last year, has been reported in the following named States (last year's corresponding figures in parentheses): New York 2 (0), New Jersey 2 (1), Indiana 2 (0), Illinois 1 (1), Maryland 3 (1), District of Columbia 1 (0), Virginia 1 (2), West Virginia 1 (0), North Carolina 2 (0), Tennessee 1 (1), Alabama 1 (0), Montana 1 (1), Wyoming 2 (4), Oregon 2 (1). Also at this date last year 2 cases had been reported in Idaho and 1 case in Nevada.

Deaths recorded during the week in 91 large cities of the United States aggregated 8,734, as compared with 9,017 last week, 8,839 for the corresponding week last year and a 3-year (1942-44) average of 8,856. The total for these cities to date is 169,936, as compared with 176,978 for the corresponding period last year.

Telegraphic morbidity reports from State health officers for the week ended May 5, 1945, and comparison with corresponding week of 1944 and 5-year median

In these tables a zero indicates a definite report, while leaders imply that, although none was reported, cases may have occurred.

Division and State	Diphtheria			Influenza			Measles			Meningitis, meningococcus		
	Week ended—		Med-ian 1940- 44	Week ended—		Med-ian 1940- 44	Week ended—		Med-ian 1940- 44	Week ended—		Med-ian 1940- 44
	May 5, 1945	May 6, 1944		May 5, 1945	May 6, 1944		May 5, 1945	May 6, 1944		May 5, 1945	May 6, 1944	
NEW ENGLAND												
Maine.....	0	2	0	-----	1	1	3	238	199	1	1	1
New Hampshire.....	0	0	0	-----	2	-----	0	23	23	0	0	0
Vermont.....	0	0	0	-----	-----	-----	5	145	145	0	0	0
Massachusetts.....	9	8	2	-----	-----	-----	150	952	975	5	8	7
Rhode Island.....	0	1	1	27	23	-----	11	102	102	1	2	1
Connecticut.....	2	0	1	3	-----	1	110	610	442	2	7	1
MIDDLE ATLANTIC												
New York.....	16	12	12	11	11	18	130	1,624	1,624	15	50	19
New Jersey.....	5	1	4	3	-----	6	57	1,252	1,252	3	16	4
Pennsylvania.....	5	10	10	1	2	1	408	818	1,678	13	40	5
EAST NORTH CENTRAL												
Ohio.....	6	8	8	6	10	10	77	591	591	8	31	3
Indiana.....	3	4	4	13	3	10	33	261	261	2	9	2
Illinois.....	2	5	18	5	40	13	220	719	719	15	22	1
Michigan ¹	3	5	4	3	1	2	290	1,067	1,067	2	13	2
Wisconsin.....	1	0	0	58	51	38	83	2,293	1,854	1	5	1
WEST NORTH CENTRAL												
Minnesota.....	3	6	3	-----	1	1	15	511	390	3	4	0
Iowa.....	3	2	2	-----	-----	-----	52	278	249	0	2	0
Missouri.....	2	0	2	1	3	-----	12	183	282	2	15	3
North Dakota.....	6	1	1	33	55	6	2	6	31	1	1	0
South Dakota.....	2	0	0	-----	-----	-----	15	39	23	1	0	1
Nebraska.....	3	3	1	-----	8	3	44	220	157	0	2	0
Kansas.....	13	2	2	-----	-----	1	43	633	645	2	5	1
SOUTH ATLANTIC												
Delaware.....	0	0	0	-----	-----	-----	11	30	30	0	3	1
Maryland ¹	11	7	4	2	6	6	43	664	403	3	10	8
District of Columbia.....	0	0	0	-----	1	-----	6	179	121	2	0	0
Virginia.....	2	4	4	56	143	143	65	680	452	7	14	4
West Virginia.....	3	5	5	7	15	15	18	415	102	1	5	2
North Carolina.....	6	4	7	6	15	8	58	1,136	543	3	8	2
South Carolina.....	3	2	2	207	229	270	21	349	141	3	4	3
Georgia.....	2	1	3	2	2	29	6	128	164	0	3	1
Florida.....	3	2	2	1	3	4	11	221	221	3	10	0
EAST SOUTH CENTRAL												
Kentucky.....	1	1	4	-----	165	7	30	153	153	2	3	3
Tennessee.....	2	6	4	10	26	26	65	196	196	4	10	2
Alabama.....	7	5	5	12	21	45	8	322	198	2	11	3
Mississippi ¹	6	1	5	-----	-----	-----	-----	-----	-----	4	4	1
WEST SOUTH CENTRAL												
Arkansas.....	2	0	3	11	53	53	24	162	122	4	0	0
Louisiana.....	6	7	2	4	9	5	28	124	124	2	2	2
Oklahoma.....	6	4	4	164	34	43	42	507	148	2	3	2
Texas.....	23	30	30	697	379	407	328	2,993	1,293	9	21	7
MOUNTAIN												
Montana.....	2	3	2	6	5	5	14	105	90	1	2	0
Idaho.....	1	0	0	2	-----	-----	13	174	57	0	0	0
Wyoming.....	0	1	0	-----	-----	-----	7	104	67	0	0	0
Colorado.....	9	4	11	5	19	18	39	299	299	1	3	1
New Mexico.....	4	0	0	1	8	1	16	136	36	2	0	0
Arizona.....	2	1	1	79	36	56	29	150	104	0	1	0
Utah ¹	0	0	0	-----	25	13	267	33	179	1	1	0
Nevada.....	0	0	0	-----	-----	-----	3	132	16	0	1	0
PACIFIC												
Washington.....	9	2	2	-----	-----	-----	232	307	377	3	2	1
Oregon.....	4	3	3	6	16	16	99	191	226	3	3	1
California.....	4	27	11	7	29	70	1,267	3,612	1,186	15	25	4
Total	212	190	192	1,432	1,426	1,532	4,510	26,067	26,032	154	382	89
18 weeks	5,139	4,184	5,037	59,102	329,607	160,776	54,475	454,871	340,866	4,163	9,465	1,400

¹New York City only.

²Period ended earlier than Saturday.

Telegraphic morbidity reports from State health officers for the week ended May 5, 1945, and comparison with corresponding week of 1944, and 5-year median—Con.

Division and State	Poliomyelitis			Scarlet fever			Smallpox			Typhoid and paratyphoid fever ²		
	Week ended—		Median 1940-44	Week ended—		Median 1940-44	Week ended—		Median 1940-44	Week ended—		Median 1940-44
	May 5, 1945	May 6, 1944		May 5, 1945	May 6, 1944		May 5, 1945	May 6, 1944		May 5, 1945	May 6, 1944	
NEW ENGLAND												
Maine.....	0	0	0	60	55	14	0	0	0	0	0	0
New Hampshire.....	0	0	0	29	11	9	0	0	0	0	0	0
Vermont.....	0	0	0	10	9	9	0	0	0	0	1	0
Massachusetts.....	1	0	0	309	365	294	0	0	0	0	2	2
Rhode Island.....	0	0	0	16	22	12	0	0	0	0	0	0
Connecticut.....	1	0	0	57	100	93	0	0	0	1	1	1
MIDDLE ATLANTIC												
New York.....	2	1	1	740	595	553	0	0	0	2	2	5
New Jersey.....	1	0	0	153	235	235	0	0	0	0	0	3
Pennsylvania.....	0	0	0	508	757	423	0	0	0	3	7	7
EAST NORTH CENTRAL												
Ohio.....	1	0	1	398	546	320	0	0	0	5	4	4
Indiana.....	1	0	0	89	255	103	14	4	4	0	2	2
Illinois.....	0	0	0	279	419	287	0	0	1	8	1	2
Michigan ³	0	0	0	269	224	224	0	0	1	1	1	1
Wisconsin.....	0	0	0	193	384	167	0	2	1	0	2	0
WEST NORTH CENTRAL												
Minnesota.....	1	0	0	72	161	79	0	0	0	0	0	0
Iowa.....	1	0	0	28	225	53	0	2	2	0	0	0
Missouri.....	0	0	0	53	129	91	0	0	0	0	3	1
North Dakota.....	0	0	0	19	30	11	0	0	0	0	0	0
South Dakota.....	0	0	0	19	39	19	1	0	1	0	0	0
Nebraska.....	0	0	0	94	66	24	0	1	0	0	0	0
Kansas.....	0	2	1	74	81	46	0	1	0	1	0	0
SOUTH ATLANTIC												
Delaware.....	0	0	0	5	20	17	0	0	0	0	0	0
Maryland ³	0	0	0	144	260	76	0	0	0	1	1	2
District of Columbia.....	0	0	0	27	146	22	0	0	0	1	1	1
Virginia.....	1	0	0	93	84	39	0	0	0	1	3	2
West Virginia.....	0	0	0	48	85	41	0	0	0	1	1	1
North Carolina.....	1	0	0	57	35	35	0	0	0	2	2	1
South Carolina.....	0	0	0	6	1	3	0	0	0	2	3	3
Georgia.....	1	0	0	28	25	13	0	0	0	2	0	2
Florida.....	0	3	0	3	5	3	0	0	0	2	2	3
EAST SOUTH CENTRAL												
Kentucky.....	1	0	0	32	76	76	0	0	0	1	1	5
Tennessee.....	1	0	0	41	62	62	0	0	0	2	1	2
Alabama.....	2	0	0	13	9	12	0	1	1	1	3	2
Mississippi ³	0	0	0	12	2	5	0	1	1	1	1	1
WEST SOUTH CENTRAL												
Arkansas.....	0	1	0	11	7	3	0	0	0	3	2	2
Louisiana.....	3	0	0	6	6	6	3	1	0	2	3	2
Oklahoma.....	0	1	1	24	27	18	0	0	0	0	2	0
Texas.....	6	1	2	82	63	48	0	0	5	9	8	6
MOUNTAIN												
Montana.....	0	1	0	17	48	24	0	0	0	1	0	0
Idaho.....	0	0	0	31	37	5	0	0	0	1	0	0
Wyoming.....	0	0	0	45	16	9	0	0	0	0	0	0
Colorado.....	0	0	0	48	61	30	0	1	1	0	0	0
New Mexico.....	0	0	0	26	30	6	1	0	0	0	1	1
Arizona.....	0	0	0	67	13	6	0	0	0	0	0	0
Utah ³	0	0	0	22	73	13	0	0	0	0	0	0
Nevada.....	0	0	0	0	7	0	0	0	0	0	0	0
PACIFIC												
Washington.....	0	0	0	95	404	37	0	0	0	0	0	0
Oregon.....	0	1	0	23	124	16	0	0	1	0	0	0
California.....	3	3	3	335	238	126	0	1	0	0	6	4
Total.....	28	14	14	4,810	6,672	3,859	19	15	18	54	67	100
18 weeks.....	609	359	414	98,755	112,287	71,761	194	213	476	1,050	1,290	1,384

¹ Period ended earlier than Saturday.

² Including paratyphoid fever reported separately, as follows: South Carolina 1; Arkansas 1; Montana 1.

³ Correction: Colorado, week ended April 7, scarlet fever 69 cases.

Telegraphic morbidity reports from State health officers for the week ended May 5, 1945, and comparison with corresponding week of 1944, and 5-year median—Continued.

Division and State	Whooping cough			Week ended May 5, 1945							
	Week ended—		Median 1940-44	Dysentery			Encephalitis, infectious	Rocky Mt. spotted fever	Typhus fever	Typhoid fever	Un- dulant fever
	May 5, 1945	May 6, 1944		Ame- bic	Bacil- lary	Un- spec- ified					
NEW ENGLAND											
Maine.....	52	32	30	0	0	0	0	0	0	0	0
New Hampshire.....	0	1	6	0	0	0	0	0	0	0	1
Vermont.....	25	7	12	0	0	0	0	0	0	0	1
Massachusetts.....	166	93	166	0	16	0	1	0	0	0	0
Rhode Island.....	18	4	17	0	0	0	0	0	0	0	0
Connecticut.....	29	18	22	0	0	0	0	0	0	0	4
MIDDLE ATLANTIC											
New York.....	278	124	285	7	7	0	1	0	0	0	5
New Jersey.....	104	24	124	2	0	0	0	0	0	0	3
Pennsylvania.....	212	105	229	0	0	0	0	0	0	0	0
EAST NORTH CENTRAL											
Ohio.....	159	74	173	0	1	0	0	0	0	0	2
Indiana.....	21	18	42	0	0	0	0	2	0	0	0
Illinois.....	41	34	98	3	1	0	2	0	0	0	6
Michigan ²	98	83	157	2	0	0	0	0	0	0	2
Wisconsin.....	54	68	143	0	0	0	0	0	0	0	5
WEST NORTH CENTRAL											
Minnesota.....	7	12	20	6	0	0	0	0	0	0	2
Iowa.....	2	0	21	0	0	0	0	0	0	0	0
Missouri.....	25	6	11	0	0	0	0	1	0	0	0
North Dakota.....	11	1	13	0	0	1	0	0	0	0	0
South Dakota.....	0	0	1	0	0	0	0	0	0	0	1
Nebraska.....	5	9	9	0	0	0	0	0	0	0	1
Kansas.....	36	44	44	0	0	0	1	0	0	0	1
SOUTH ATLANTIC											
Delaware.....	1	1	1	0	0	0	0	0	0	0	0
Maryland ²	73	24	88	0	0	0	0	1	0	0	0
District of Columbia.....	3	3	12	0	0	0	0	0	0	0	0
Virginia.....	55	63	63	0	0	12	0	0	0	0	0
West Virginia.....	20	31	33	0	0	0	0	0	0	0	0
North Carolina.....	186	97	115	1	0	0	0	0	0	0	0
South Carolina.....	68	98	67	2	30	0	0	0	0	3	0
Georgia.....	11	14	20	0	3	0	0	0	0	3	3
Florida.....	13	42	42	1	0	0	0	0	0	3	0
EAST SOUTH CENTRAL											
Kentucky.....	27	75	79	0	0	0	0	0	0	0	0
Tennessee.....	19	29	47	0	0	0	0	0	2	0	0
Alabama.....	8	37	44	1	0	0	0	0	0	2	1
Mississippi ²				0	0	0	0	0	2	3	2
WEST SOUTH CENTRAL											
Arkansas.....	14	16	27	6	2	0	0	0	4	0	0
Louisiana.....	10	1	3	0	0	0	0	0	0	3	2
Oklahoma.....	17	39	37	0	0	0	0	0	0	1	0
Texas.....	270	195	347	9	218	84	0	0	0	28	13
MOUNTAIN											
Montana.....	5	3	15	0	0	0	0	1	0	0	0
Idaho.....	9	2	3	0	0	0	0	0	0	0	1
Wyoming.....	8	6	3	0	0	0	0	1	0	0	0
Colorado.....	34	53	23	0	0	0	0	0	0	0	1
New Mexico.....	24	4	7	0	1	0	0	0	0	0	0
Arizona.....	27	14	26	1	0	12	1	0	0	0	0
Utah ²	44	48	66	0	0	0	0	0	0	0	5
Nevada.....	0	36	3	0	0	0	0	0	0	0	0
PACIFIC											
Washington.....	17	28	64	0	0	0	0	0	0	0	1
Oregon.....	27	8	19	0	0	0	0	1	0	0	2
California.....	313	93	354	7	6	0	0	0	0	1	7
Total	2,646	1,817	3,977	48	285	109	6	6	9	52	72
Same week, 1944.....	1,817	24	291	90	18	8	9	72	53
Average, 1942-44.....	3,394	19	185	71	13	9	10	82
18 weeks: 1945.....	44,724	530	7,748	2,085	120	22	294	874	1,538
..... 1944.....	32,526	473	3,959	1,230	206	15	181	722	1,057
Average, 1942-44.....	58,179	69,361	435	2,885	914	181	38	264	654

² Period ended earlier than Saturday.

² 5-year median, 1940-44.

Amtraz: Pennsylvania, 1 case. Weil's disease: Maryland, 2 cases. Leprosy: California, week ended April 21, 1 case.

WEEKLY REPORTS FROM CITIES

City reports for week ended April 28, 1945

This table lists the reports from 88 cities of more than 10,000 population distributed throughout the United States, and represents a cross section of the current urban incidence of the diseases included in the table.

	Diphtheria cases	Erysipellitis, infectious, cases	Influenza		Measles cases	Meningitis, meningococcus, cases	Pneumonia deaths	Polymyellitis cases	Scarlet fever cases	Smallpox cases	Typhoid and paratyphoid fever cases	Whooping cough cases
			Cases	Deaths								
NEW ENGLAND												
Maine:												
Portland.....	0	0		0	0	0	1	0	3	0	0	8
New Hampshire:												
Concord.....	0	0		0	0	0	0	0	0	0	0	0
Vermont:												
Barre.....	0	0		0	0	0	0	0	5	0	0	0
Massachusetts:												
Boston.....	2	0		0	107	4	13	1	79	0	1	32
Fall River.....	0	0		0	0	0	2	0	0	0	0	1
Springfield.....	0	0		0	1	1	0	0	17	0	0	1
Worcester.....	0	0		0	9	0	10	0	18	0	0	2
Rhode Island:												
Providence.....	0	1		0	7	0	1	0	11	0	0	18
Connecticut:												
Bridgport.....	0	0		0	0	2	2	0	7	0	0	0
Hartford.....	0	0	1	0	45	0	0	0	13	0	0	1
New Haven.....	0	0		0	2	0	1	0	3	0	0	4
MIDDLE ATLANTIC												
New York:												
Buffalo.....	0	0		1	6	2	3	0	12	0	0	1
New York.....	13	1	2	2	30	10	47	3	254	0	1	104
Rochester.....	0	0		0	7	2	2	0	10	0	0	24
Syracuse.....	0	0		0	0	2	1	0	0	0	0	32
New Jersey:												
Camden.....	1	0		1	0	0	0	0	4	0	0	1
Newark.....	0	0		0	10	2	5	0	21	0	0	9
Trenton.....	0	0		0	3	0	3	0	8	0	0	6
Pennsylvania:												
Philadelphia.....	1	0	1	0	233	6	15	0	69	0	0	83
Pittsburgh.....	0	0	1	2	1	2	17	0	36	0	0	16
Reading.....	0	0		0	2	0	0	0	8	0	0	1
EAST NORTH CENTRAL												
Ohio:												
Cincinnati.....	0	0		2	2	2	8	0	26	0	0	6
Cleveland.....	0	0	2	2	17	3	7	0	61	0	0	53
Columbus.....	0	0		0	1	0	0	0	4	0	0	17
Indiana:												
Fort Wayne.....	0	0		0	0	0	2	0	7	0	0	0
Indianapolis.....	2	0		0	13	2	2	0	12	0	0	4
South Bend.....	0	0		0	1	0	0	0	3	0	0	0
Terre Haute.....	0	0		0	1	0	1	0	4	0	0	1
Illinois:												
Chicago.....	2	0	1	1	108	7	29	0	124	0	0	12
Springfield.....	0	0		0	1	0	0	0	1	0	1	0
Michigan:												
Detroit.....	5	2	2	0	93	3	8	0	111	0	1	13
Flint.....	0	0		0	7	0	1	0	20	0	0	0
Grand Rapids.....	0	0		0	6	0	0	0	14	0	0	1
Wisconsin:												
Kenosha.....	0	0		0	5	0	0	0	11	0	0	1
Milwaukee.....	0	0		0	17	2	9	0	54	0	0	2
Racine.....	0	0		0	2	0	2	0	6	0	0	4
Superior.....	0	0		0	3	0	0	0	3	0	0	0
WEST NORTH CENTRAL												
Minnesota:												
Duluth.....	1	0		0	0	0	0	0	9	0	0	0
Minneapolis.....	0	0		0	7	1	1	0	20	0	0	3
St. Paul.....	1	0		0	2	0	5	1	5	0	0	6
Missouri:												
Kansas City.....	0	0		0	5	0	7	0	10	0	0	1
St. Joseph.....	0	0		0	2	1	0	0	2	0	0	0
St. Louis.....	0	0		0	6	4	10	0	26	0	0	15

City reports for week ended April 28, 1945—Continued

	Diphtheria cases	Erysipelas, infectious, cases	Influenza		Measles cases	Meningitis, meningococcus, cases	Pneumonia deaths	Polymyolitis cases	Scarlet fever cases	Smallpox cases	Typhoid and paratyphoid fever cases	Whooping cough cases
			Cases	Deaths								
WEST NORTH CENTRAL—continued												
North Dakota:												
Fargo.....	0	0	0	0	3	0	0	0	0	0	0	0
Nebraska:												
Omaha.....	1	0	0	0	17	0	3	0	15	0	0	0
Kansas:												
Topeka.....	0	0	0	0	3	0	0	0	9	0	0	0
Wichita.....	1	0	0	0	3	0	2	0	7	0	0	6
SOUTH ATLANTIC												
Delaware:												
Wilmington.....	0	0	0	0	1	0	0	0	3	0	0	1
Maryland:												
Baltimore.....	13	0	0	0	6	0	10	0	86	0	0	60
Cumberland.....	0	0	0	0	0	0	1	0	3	0	0	0
Frederick.....	0	0	0	0	0	0	0	0	1	0	0	0
District of Columbia:												
Washington.....	0	0	0	0	8	2	8	0	23	0	0	6
Virginia:												
Lynchburg.....	0	0	1	0	0	0	1	0	2	0	0	0
Richmond.....	0	0	0	0	2	0	2	0	8	0	0	5
Roanoke.....	0	0	0	0	0	0	1	0	4	0	0	0
West Virginia:												
Wheeling.....	0	0	0	0	7	0	2	0	1	0	0	0
North Carolina:												
Raleigh.....	0	0	0	0	16	0	0	0	0	0	0	8
Wilmington.....	0	0	0	0	5	0	1	0	1	0	0	12
Winston-Salem.....	0	0	0	0	1	0	0	0	3	0	0	10
South Carolina:												
Charleston.....	0	0	1	0	10	1	2	0	1	0	0	0
Georgia:												
Atlanta.....	0	0	0	0	0	0	2	1	15	0	0	1
Brunswick.....	0	0	0	0	1	0	0	0	0	0	0	0
Florida:												
Tampa.....	0	0	0	0	0	2	4	0	2	0	0	3
EAST SOUTH CENTRAL												
Tennessee:												
Memphis.....	0	0	2	2	45	1	9	0	10	0	0	9
Nashville.....	0	0	2	2	2	0	2	0	0	0	1	0
Alabama:												
Birmingham.....	0	0	1	0	0	1	3	0	4	0	0	3
Mobile.....	0	0	0	0	0	0	2	0	1	0	0	0
WEST SOUTH CENTRAL												
Arkansas:												
Little Rock.....	0	0	0	0	9	0	1	0	1	0	0	1
Louisiana:												
New Orleans.....	1	0	1	1	33	0	5	0	10	0	0	3
Shreveport.....	0	0	0	0	0	0	3	0	0	0	1	0
Texas:												
Dallas.....	1	0	0	0	9	0	4	0	6	0	2	1
Galveston.....	0	0	0	0	0	0	0	0	0	0	0	0
Houston.....	6	0	0	1	2	3	1	2	0	0	0	1
San Antonio.....	0	0	2	0	0	0	2	0	3	0	0	4
MOUNTAIN												
Montana:												
Billings.....	0	0	0	0	1	0	1	0	1	0	0	0
Great Falls.....	0	0	0	0	0	0	1	0	0	0	0	1
Helena.....	0	0	0	0	0	0	0	0	0	0	0	0
Missoula.....	1	0	0	0	0	0	0	0	2	0	0	0
Idaho:												
Boise.....	0	0	0	0	0	0	0	0	0	0	0	4
Colorado:												
Denver.....	3	0	1	0	8	1	6	0	15	0	0	26
Pueblo.....	0	0	0	0	0	0	2	0	1	0	0	6
Utah:												
Salt Lake City.....	0	0	0	0	148	0	3	0	10	0	0	15

City reports for week ended April 23, 1945—Continued

	Diphtheria cases	Enecephalitis, infectious, cases	Influenza		Measles cases	Meningitis, non-infectious, cases	Pneumonia deaths	Poliomyelitis cases	Scarlet fever cases	Smallpox cases	Typhoid and paratyphoid fever cases	Whooping cough cases
			Cases	Deaths								
PACIFIC												
Washington:												
Seattle.....	3	0	-----	0	25	1	11	0	21	0	0	2
Spokane.....	0	0	-----	0	0	0	0	0	0	0	0	1
Tacoma.....	0	0	-----	0	7	0	4	0	5	0	0	0
California:												
Los Angeles.....	1	0	3	1	74	4	5	0	72	0	0	25
Sacramento.....	0	0	-----	0	8	0	0	0	11	0	0	10
San Francisco.....	5	0	-----	0	182	3	7	0	63	0	0	14
Total.....	64	4	21	18	1,397	76	328	7	1,539	0	8	721
Corresponding week, 1944.....	57	-----	48	29	6,097	-----	400	-----	2,338	0	14	277
Average, 1940-44.....	60	-----	44	129	6,573	-----	1415	-----	1,724	2	14	1,022

13-year average, 1942-44.
 5-year median, 1940-44.

Dysentery, amebic.—Cases: New York, 9; Chicago, 1; Detroit 1; St. Louis, 2.
Dysentery, bacillary.—Cases: Buffalo, 4; New York, 5; Detroit, 1; Charleston, S. C., 4; Los Angeles, 2.
Dysentery, unspecified.—Cases: San Antonio, 37.
Rocky Mountain spotted fever.—Cases: Baltimore, 1; San Francisco, 1.
Typhus fever, endemic.—Cases: Tampa, 2; New Orleans 3; San Antonio, 2.

Rates (annual basis) per 100,000 population, by geographic groups, for the 88 cities in the preceding table (estimated population, 1943, 34,197,800)

	Diphtheria case rates	Enecephalitis, infectious, case rates	Influenza		Measles case rates	Meningitis, meningococcus, case rates	Pneumonia death rates	Poliomyelitis case rates	Scarlet fever case rates	Smallpox case rates	Typhoid and paratyphoid fever case rates	Whooping cough case rates
			Case rates	Death rates								
New England.....	5.2	2.6	2.6	0.0	447	18.3	78.4	2.6	406	0.0	2.6	175
Middle Atlantic.....	6.9	0.5	1.9	2.8	135	12.0	43.0	1.4	195	0.0	0.5	128
East North Central.....	5.5	1.2	3.0	3.0	168	11.6	42.0	0.0	290	0.0	1.2	69
West North Central.....	2.0	0.0	0.0	0.0	95	11.9	55.7	2.0	205	0.0	0.0	62
South Atlantic.....	22.6	0.0	1.7	1.7	99	8.7	59.2	1.7	266	0.0	0.0	185
East South Central.....	0.0	0.0	17.7	23.6	277	11.8	94.4	0.0	89	0.0	5.9	71
West South Central.....	23.0	0.0	8.6	2.9	149	5.7	51.7	2.9	63	0.0	8.6	29
Mountain.....	31.8	0.0	7.9	0.0	1,247	7.9	103.3	0.0	230	0.0	0.0	413
Pacific.....	14.2	0.0	4.7	1.6	468	12.7	42.7	0.0	282	0.0	0.0	82
Total.....	9.8	0.6	3.2	2.8	214	11.6	50.1	1.1	235	0.0	1.2	110

TERRITORIES AND POSSESSIONS

Puerto Rico

Notifiable diseases—4 weeks ended April 21, 1945.—During the 4 weeks ended April 21, 1945, cases of certain notifiable diseases were reported in Puerto Rico as follows:

Disease	Cases	Disease	Cases
Bilharziasis.....	4	Scarlet fever.....	1
Chickenpox.....	47	Syphilis.....	405
Diphtheria.....	33	Tetanus.....	14
Dysentery (unspecified).....	2	Tetanus, infantile.....	1
Gonorrhoea.....	352	Trachoma.....	1
Influenza.....	72	Tuberculosis (all forms).....	493
Malaria.....	271	Typhoid fever.....	30
Measles.....	199	Typhus fever (murine).....	7
Mumps.....	2	Whooping cough.....	90
Poliomyelitis.....	1		

FOREIGN REPORTS

CANADA

Provinces—Communicable diseases—Week ended April 14, 1945.—During the week ended April 14, 1945, cases of certain communicable diseases were reported by the Dominion Bureau of Statistics of Canada as follows:

Disease	Prince Edward Island	Nova Scotia	New Brunswick	Quebec	Ontario	Manitoba	Saskatchewan	Alberta	British Columbia	Total
Chickenpox.....		26		145	271	63	32	48	84	669
Diphtheria.....		2	1		21	8	1		2	35
Dysentery:				2					2	4
Bacillary.....										
Unspecified.....									2	10
German measles.....		13		7	26	1	2	19	25	93
Influenza.....		45			30	1			46	122
Measles.....		2	2	129	107	9	47	25	343	664
Meningitis, meningococcus.....						1		1	2	4
Mumps.....		6		159	131	53	26	129	29	533
Poliomyelitis.....						2				2
Scarlet fever.....		4	12	60	63	8	10	43	31	231
Tuberculosis (all forms).....		8	2	120	66	14	6	44	82	342
Typhoid and paratyphoid fever.....			1	2	4					7
Undulant fever.....				6	2				2	10
Veneral diseases:										
Gonorrhoea.....	1	37	34	75	139	29	30	39	75	459
Syphilis.....	1	19	18	107	83	13	11	10	26	288
Whooping cough.....		17		135	44	17	5	43	15	276

GOLD COAST

Cerebrospinal meningitis.—Cerebrospinal meningitis has been reported in the colony of Gold Coast as follows: Week ended February 24, 1945, 1,197 cases, 128 deaths; week ended March 3, 1945, 1,368 cases, 164 deaths.

JAMAICA

Notifiable diseases—4 weeks ended March 10, 1945.—During the 4 weeks ended March 10, 1945, cases of certain notifiable diseases were reported in Kingston, Jamaica, and in the island outside of Kingston, as follows:

Disease	Kingston	Other localities	Disease	Kingston	Other localities
Cerebrospinal meningitis.....	1		Puerperal fever.....		2
Chickenpox.....	31	40	Scarlet fever.....	2	
Diphtheria.....	6	7	Tuberculosis (pulmonary).....	41	48
Dysentery (unspecified).....	7	12	Typhoid fever.....	14	81
Erysipelas.....	2	2	Typhus fever (murine).....	2	1
Leprosy.....		2			

NEW ZEALAND

Notifiable diseases—4 weeks ended March 24, 1945.—During the 4 weeks ended March 24, 1945, certain notifiable diseases were reported in New Zealand as follows:

Disease	Cases	Deaths	Disease	Cases	Deaths
Cerebrospinal meningitis.....	16	-----	Poliomyelitis.....	2	-----
Dengue.....	1	-----	Puerperal fever.....	9	-----
Diphtheria.....	98	7	Scarlet fever.....	514	-----
Dysentery, bacillary.....	36	3	Tetanus.....	2	-----
Erysipelas.....	26	-----	Trachoma.....	7	-----
Food poisoning.....	3	-----	Tuberculosis (all forms).....	211	51
Hookworm disease.....	2	-----	Typhoid fever.....	4	1
Malaria.....	14	-----	Undulant fever.....	1	-----
Ophthalmia neonatorum.....	1	-----			

WORLD DISTRIBUTION OF CHOLERA, PLAGUE, SMALLPOX, TYPHUS FEVER, AND YELLOW FEVER

From medical officers of the Public Health Service, American consuls, International Office of Public Health, Pan American Sanitary Bureau, health section of the League of Nations, and other sources. The reports contained in the following tables must not be considered as complete or final as regards either the list of countries included or the figures for the particular countries for which reports are given.

CHOLERA

[C indicates cases]

¹NOTE.—Since many of the figures in the following tables are from weekly reports, the accumulated totals are for approximate dates.

Place		January-February 1945	March 1945	April 1945—week ended—			
				7	14	21	28
ASIA							
India.....	C	12,209					
Bombay.....	C	6	2				
Calcutta.....	C	185	588	294	452		
Chittagong.....	C	2	6				
Madras.....	C	33	12				

PLAGUE

[C indicates cases; P, present]

AFRICA							
Algeria.....	C	19					
Bechuanaland.....	C	7					
Belgian Congo.....	C	4					
British East Africa:							
Kenya.....	C	2					
Uganda.....	C	2					1
Egypt:							
Port Said.....	C	5	8				
Suez.....	C	3	2				
Suez.....	C	2					
French West Africa:							
Dakar.....	C	4	1				
Dakar.....	C	1					
Madagascar.....	C	46	5				
Morocco (French).....	C	47	60		8		
Senegal.....	C	54					
Tunisia.....	C	2	1				
Union of South Africa.....	C	4	1				
ASIA							
India.....	C ¹	8,558					
Iraq.....	C	34					
Palestine.....	C	5	1	1			
Plague-infected rats.....	P						
EUROPE							
Portugal: Azores.....	C	1	2				

¹ Includes 1 case of pneumonic plague.

PLAGUE—Continued

Place	January-February 1945	March 1945	April 1945—week ended—			
			7	14	21	28
SOUTH AMERICA						
Ecuador: Chimborazo Province..... C	2	1	-----	-----	-----	-----
Peru:						
Lambayeque Department..... C	1	-----	-----	-----	-----	-----
Libertad Department..... C	3	-----	-----	-----	-----	-----
Lima Department..... C	5	-----	-----	-----	-----	-----
OCEANIA						
Hawaii Territory: Plague-infected rats ²	3	4	-----	-----	-----	-----

² Plague infection was also proved positive in a pool of 5 mice on Jan. 4, in a pool of fleas on Feb. 14, and in a pool of 40 fleas on Mar. 14, 1945.

SMALLPOX

[C indicates cases]

AFRICA					
Algeria..... C	60	34	-----	-----	-----
Basutoland..... C	31	35	-----	-----	-----
Belgian Congo..... C	1, 196	466	-----	-----	-----
British East Africa:					
Kenya..... C	69	27	-----	-----	-----
Tanganyika..... C	151	883	-----	-----	-----
Uganda..... C	183	180	-----	-----	-----
Cameroon (French)..... C	46	205	1 8	-----	-----
Dahomey..... C	35	12	1 9	-----	-----
Egypt..... C	269	237	-----	-----	-----
French Equatorial Africa..... C	1, 108	217	-----	-----	-----
French Guinea..... C	390	379	1 195	-----	-----
French West Africa..... C	149	99	1 28	-----	-----
Gambia..... C	5	21	7	-----	-----
Gold Coast..... C	21	5	-----	-----	-----
Ivory Coast..... C	20	113	1 44	-----	-----
Mauritania..... C	2	-----	-----	-----	-----
Morocco (French)..... C	41	77	1 21	-----	-----
Nigeria..... C	1, 305	553	-----	-----	-----
Niger Territory..... C	86	116	1 26	-----	-----
Rhodesia, Northern..... C	143	206	-----	-----	-----
Senegal..... C	120	61	1 46	-----	-----
Sudan (French)..... C	409	274	1 101	-----	-----
Togo (British)..... C	-----	25	-----	-----	-----
Togo (French)..... C	174	134	1 2	-----	-----
Union of South Africa..... C	394	-----	-----	-----	-----
ASIA					
Arabia..... C	5	11	-----	-----	-----
Ceylon..... C	2 125	31	-----	-----	-----
China: Kunming (Yunnan Fu)..... C	2	3	-----	-----	-----
India..... C	50, 746	-----	-----	-----	-----
Syria and Lebanon..... C	5	1	-----	-----	-----
EUROPE					
Belgium..... C	1	-----	-----	-----	-----
France..... C	2	-----	-----	-----	-----
Great Britain: Scotland..... C	-----	1	1	-----	-----
Italy..... C	431	188	16	-----	-----
Portugal..... C	1	1	-----	-----	-----
Spain..... C	22	-----	-----	-----	-----
Turkey..... C	129	130	11	3	1
NORTH AMERICA					
Canada..... C	6	-----	-----	-----	-----
Guatemala..... C	-----	1	-----	-----	-----
Mexico..... C	141	-----	-----	-----	-----
Nicaragua..... C	123	-----	-----	-----	-----
SOUTH AMERICA					
Brazil..... C	39	6	1	-----	-----
Colombia..... C	16	51	15	-----	-----
Ecuador..... C	7	3	-----	-----	-----
Paraguay..... C	1	-----	-----	-----	-----
Venezuela..... C	4 171	4 196	-----	-----	-----

¹ For the period Apr. 1-10, 1945.

² Includes some cases of chickenpox.

³ Imported.

⁴ Reported as alastrim.

TYPHUS FEVER*

[C indicates cases]

Place	January-February 1945	March 1945	April 1945—week ended—			
			7	14	21	28
AFRICA						
Algeria.....	C 388	233				
Basutoland.....	C 2	1				
Belgian Congo ¹	C 11	6				
British East Africa: Kenya.....	C 10	5				
Egypt.....	C 2,664	3,846				
French West Africa: Dakar ¹	C 2					
Libya: Tripolitania.....	C 7					
Morocco (French).....	C 979	1,184	2	558		
Rhodesia, Northern.....	C 6	5				
Tunisia.....	C 57	31	2	124		
Union of South Africa.....	C 158					
ASIA						
China: Kunming (Yunnan Fu).....	C 21	7				
India.....	C 9					
Iran.....	C 44	3				
Iraq.....	C 2					
Palestine ¹	C 14	5	2			
Syria and Lebanon.....	C	5				
Trans-Jordan.....	C 23					
EUROPE						
Albania.....	C 100					
Bulgaria.....	C 264	213				
France.....	C 3					
Gibraltar.....	C 3	1				
Great Britain.....	C	41				
Greece.....	C 14					
Italy.....	C 5					
Malta and Gozo ¹	C 6					
Portugal.....	C 22	13	4			
Rumania.....	C 7,831					
Spain.....	C 4					
Turkey.....	C 795	444	5	104	86	
Yugoslavia.....	C 137					
NORTH AMERICA						
Canada ¹	C	1				
Cuba ¹	C 1					
Guatemala.....	C 334	153				
Jamaica.....	C 4	3				
Mexico.....	C 55					
Panama (Republic).....	C 1					
Puerto Rico ¹	C 5	9	3	2	1	
Virgin Islands ¹	C 4					
SOUTH AMERICA						
Brazil.....	C 1					
Chile ¹	C 40					
Curacao.....	C	1				
Ecuador.....	C 72	37		11		
Venezuela ¹	C 14	21				
OCEANIA						
Australia.....	C 17	16				
Hawaii Territory.....	C 10	9				

* Reports from some areas are probably murine type, while others probably include both murine and louse-borne types.

¹ Reports cases as murine type.

² For the period Apr. 1-10, 1945.

³ For the months of February and March 1945.

⁴ Imported.

YELLOW FEVER
 [C indicates cases; D, deaths]

Place	January-February 1945	March 1945	April 1945—week ended—			
			7	14	21	28
AFRICA						
Ivory Coast: Guiglo.....	C	1				
SOUTH AMERICA						
Brazil:						
Goiaz State.....	D	57				
Minas Geraes State.....	D	4				
Colombia: Santander del Norte Department..	D	15				
Peru: Cuzco Department.....	C	1			1	
Venezuela:						
Bolivar State.....	C			1		
Tachira State.....	D	2				

¹ For the period Jan. 1 to Mar. 11, 1945.

X