

**CONTROL TECHNOLOGY FOR ETHYLENE OXIDE  
STERILIZATION IN HOSPITALS**

**Vincent D. Mortimer, Jr.  
Sharon L. Kercher**

**U.S. DEPARTMENT OF HEALTH AND HUMAN SERVICES  
Public Health Service  
Centers for Disease Control  
National Institute for Occupational Safety and Health (NIOSH)  
Division of Physical Sciences and Engineering  
Cincinnati, Ohio 45226**

**September 1989**

**DISCLAIMER**

**Mention of company names or products does not constitute endorsement by the National Institute for Occupational Safety and Health.**

**DHHS (NIOSH) Publication No. 89-120**

## PREFACE

Under the authority of the Occupational Safety and Health Act of 1970 (Public Law 91-596), the National Institute for Occupational Safety and Health (NIOSH) conducts research to prevent occupational health problems through the application of control technology in the workplace. The goal of this program is to assist in preventing hazardous exposures to workers and to document successful approaches and applications of control measures.

In 1982-83, the Engineering Control Technology Branch, Division of Physical Sciences and Engineering, NIOSH, conducted a feasibility study of the use of engineering controls in hospitals. As a result of research recommendations from that study and in response to the hospitals' need to control worker exposure to ethylene oxide, a study of the control of ethylene oxide (EtO) emissions from sterilizers in the hospital setting was conducted from 1984-86. The goals of this study were to evaluate and document effective engineering controls which selected hospitals have implemented, and to disseminate useful information and practicable recommendations on effective methods for controlling occupational EtO exposure.

This report examines control methods and systems for EtO sterilization in hospitals. Nine sterilizer control systems were evaluated in eight hospitals during week-long, industrial hygiene surveys. Individual in-depth survey reports (listed in Appendix C) which include more detailed information on specific characteristics of each control system are available from the National Technical Information Service, Port Royal Road, Springfield, Virginia 22161.

As a follow-up to this report, a hazard and operability (HAZOP) study was conducted on a model sterilizer installation. The HAZOP was performed primarily to evaluate the potential for catastrophic release of ethylene oxide due to failure of one or more sterilizer components, installation inadequacies, or worker actions. It has the advantage of looking at what could happen, whereas the field studies focus on conditions present at the time of the survey. The recommendations of the HAZOP complement those of the field study and are summarized as an appendix to this report.

## ABSTRACT

This report examines control methods and systems for EtO sterilization in hospitals. Nine sterilizer control systems were evaluated in eight hospitals during week-long, in-depth surveys. Three emission sources typically account for most of the EtO routinely released into the work environment. First, most of the EtO gas mixture from the chamber is released to the indoor atmosphere at the air gap located at the connection of the drain to the outlet of the water sealed vacuum pump. Second, the opening of the sterilizer door at the completion of the cycle may result in a very short high exposure to the sterilizer operator followed by an increase in the workroom EtO concentration. Third, the load transfer procedure provides the closest contact with EtO for the sterilizer operator: pulling the load from the sterilizer, transporting the load to the aerator, and inserting the load into the aerator. EtO exposures from hospital sterilizers can be controlled to not exceed a ceiling limit of 5 ppm and to average less than 0.1 ppm for a full shift. All but one of the hospitals surveyed in this study had short-term exposures less than 2 ppm and full-shift exposures less than 0.1 ppm.

The extent of control needed by a hospital will depend on a number of factors such as the composition and size of the sterilized load, the location of the sterilizer and the time constraints on sterilization, the type of sterilizer and the types of controls selected, and the level to which EtO exposures are to be controlled. In-chamber aeration, which substantially eliminates any exposure, is the best control. When it is not possible to fully use in-chamber aeration, cycle modifications, local ventilation above the sterilizer door, and a ventilated enclosure around the sterilizer drain are the next most effective techniques for reducing exposures. General ventilation did not seem to be as important as other control techniques in controlling EtO exposures.

## ABBREVIATIONS

|                            |   |
|----------------------------|---|
| <b>AAMI</b>                | <b>Association for the Advancement of Medical Instrumentation</b>                 |
| <b>ASHRAE</b>              | <b>American Society of Heating, Refrigerating, and Air Conditioning Engineers</b> |
| <b>BI</b>                  | <b>Biological indicator</b>   |
| <b>cfm</b>                 | <b>cubic feet per minute</b>  |
| <b>cfm/ft<sup>2</sup></b>  | <b>cubic feet per minute per square foot</b>                                      |
| <b>CS</b>                  | <b>Central service</b>  |
| <b>dc</b>                  | <b>Door-cracked period</b>  |
| <b>DHEW</b>                | <b>Department of Health, Education, and Welfare</b>                               |
| <b>DHHS</b>                | <b>Department of Health and Human Services</b>                                    |
| <b>do</b>                  | <b>Door-open period</b>   |
| <b>EtO</b>                 | <b>Ethylene oxide</b>   |
| <b>ft<sup>3</sup></b>      | <b>Cubic feet</b>   |
| <b>ft<sup>3</sup>/hour</b> | <b>Cubic feet per hour</b>  |
| <b>ft<sup>3</sup>/min</b>  | <b>Cubic feet per minute</b>  |
| <b>ft/min</b>              | <b>Feet per minute</b>  |
| <b>HAZOP</b>               | <b>Hazard and operability study</b>   |
| <b>IPPB</b>                | <b>Intermittent, positive pressure, breathing</b>                                 |
| <b>IR</b>                  | <b>Infrared</b>   |
| <b>LEV</b>                 | <b>Local exhaust ventilation</b>  |
| <b>LOD</b>                 | <b>Limit of detection</b>   |
| <b>LT</b>                  | <b>Load transfer</b>  |
| <b>mL/min</b>              | <b>Milliliters of air per minute</b>  |
| <b>NFPA</b>                | <b>National Fire Prevention Association</b>                                       |
| <b>NIOSH</b>               | <b>National Institute for Occupational Safety and Health</b>                      |
| <b>OSHA</b>                | <b>Occupational Safety and Health Administration</b>                              |
| <b>PEL</b>                 | <b>Permissible exposure limit</b>   |
| <b>ppm</b>                 | <b>Parts per million parts of air</b>   |
| <b>ppm-min</b>             | <b>Parts per million minutes</b>  |
| <b>SCBA</b>                | <b>Self-contained breathing apparatus</b>   |
| <b>STEL</b>                | <b>Short-term exposure limit</b>  |

## CONTENTS

|   |    |
|---|----|
| ABSTRACT . . . . .  | iv |
| ABBREVIATIONS . . . . .   | v  |
| ACKNOWLEDGMENTS . . . . .   | xi |
| INTRODUCTION . . . . .  | 1  |
| THE NEED FOR CONTROLS . . . . .   | 2  |
| ETHYLENE OXIDE - BACKGROUND AND STERILIZATION CHARACTERISTICS . . . . . | 2  |
| ETHYLENE OXIDE TOXICITY . . . . .                                       | 3  |
| Acute Health Effects . . . . .  | 3  |
| Carcinogenicity . . . . .   | 4  |
| Mutagenicity and Cytogenicity . . . . .                                 | 5  |
| Reproductive Effects . . . . .  | 6  |
| Dose-Rate Effect . . . . .  | 7  |
| Conclusions . . . . .   | 7  |
| EXPOSURE LIMITS . . . . .   | 7  |
| Potential for Overexposure . . . . .                                    | 9  |
| BASIS FOR CONTROL - PROCESSES AND EMISSION SOURCES . . . . .            | 10 |
| HOSPITAL STERILIZATION . . . . .  | 10 |
| Department Description . . . . .  | 10 |
| Process Description . . . . .   | 11 |
| ETHYLENE OXIDE EMISSION SOURCES . . . . .                               | 15 |
| Potential Release of Large Quantities of EtO . . . . .                  | 15 |
| Routine Sources Which May Cause High Concentrations . . . . .           | 16 |
| Sources of Low Concentrations . . . . .                                 | 17 |
| OVERVIEW OF CONTROL TECHNIQUES . . . . .                                | 18 |
| SUBSTITUTION . . . . .  | 18 |
| ISOLATION . . . . .   | 18 |
| Sterilization Operations . . . . .                                      | 18 |
| Aeration . . . . .  | 19 |
| EQUIPMENT MODIFICATION . . . . .  | 19 |
| Chamber Evacuation/Flushing . . . . .                                   | 20 |
| Pulse Purge . . . . .   | 20 |
| Closed-Door Air Flush . . . . .   | 20 |
| In-Chamber Aeration . . . . .   | 21 |
| Door-Cracked Period . . . . .   | 21 |
| Antisiphon Air Gap . . . . .  | 21 |
| Power Door . . . . .  | 21 |
| Interlocks . . . . .  | 22 |
| Safety Valves . . . . .   | 22 |
| Aeration . . . . .  | 22 |
| LOCAL EXHAUST VENTILATION . . . . .                                     | 22 |
| Sterilizer Door . . . . .   | 23 |
| Drain . . . . .   | 24 |
| Supply Cylinders . . . . .  | 24 |
| Overpressure Relief Valve . . . . .                                     | 25 |

CONTENTS (continued)

|   |    |
|---|----|
| Inspection Table Ventilation . . . . .                          | 25 |
| Aerator Ventilation . . . . .                                   | 25 |
| GENERAL VENTILATION . . . . .                                   | 25 |
| WORK PRACTICES . . . . .  | 28 |
| MAINTENANCE . . . . .   | 28 |
| MONITORING . . . . .  | 29 |
| Air Sampling Methods . . . . .                                  | 29 |
| Air Sampling Strategies . . . . .                               | 29 |
| Real-Time Monitoring Systems . . . . .                          | 30 |
| Sterilizer and Ventilation Monitors . . . . .                   | 30 |
| EtO Sensors . . . . .   | 30 |
| THE EVALUATION OF CONTROL EFFECTIVENESS . . . . .               | 33 |
| HOSPITAL SELECTION . . . . .                                    | 33 |
| AIR SAMPLING . . . . .  | 33 |
| Charcoal Tubes . . . . .  | 35 |
| Gas Bags/Portable GC . . . . .                                  | 35 |
| Infrared Analyzer . . . . .                                     | 37 |
| EVALUATION OF VENTILATION SYSTEMS . . . . .                     | 38 |
| Local Exhaust Ventilation . . . . .                             | 38 |
| General Ventilation . . . . .                                   | 38 |
| EVALUATION OF WORK PRACTICES . . . . .                          | 39 |
| ANALYSIS OF DATA . . . . .                                      | 40 |
| RESULTS . . . . .   | 41 |
| AIR SAMPLING . . . . .  | 41 |
| Charcoal Tubes . . . . .  | 43 |
| Full-Shift Results . . . . .                                    | 43 |
| Short-Term Results . . . . .                                    | 43 |
| Gas Bags/Portable Gas Chromatograph . . . . .                   | 51 |
| Infrared Analyzer . . . . .                                     | 56 |
| VENTILATION . . . . .   | 56 |
| Local Exhaust Ventilation . . . . .                             | 56 |
| General Ventilation . . . . .                                   | 56 |
| Work Practices . . . . .  | 61 |
| DISCUSSION OF CONTROLS . . . . .                                | 63 |
| CYCLE MODIFICATIONS . . . . .                                   | 63 |
| Deep-Vacuum Purges . . . . .                                    | 65 |
| Pulse-Purge Cycle . . . . .                                     | 65 |
| Closed-Door Air Flush Period . . . . .                          | 65 |
| Door-Cracked Period . . . . .                                   | 66 |
| In-Chamber Aeration . . . . .                                   | 66 |
| STERILIZER DOOR . . . . .                                       | 67 |
| VENTILATED AIR GAP ENCLOSURE . . . . .                          | 72 |
| SUPPLY CYLINDERS . . . . .                                      | 72 |
| RELIEF VALVE . . . . .  | 74 |
| MECHANICAL ACCESS ROOM/STERILIZER CABINET VENTILATION . . . . . | 74 |
| DEDICATED EXHAUST . . . . .                                     | 77 |
| EtO DISCHARGE LOCATION . . . . .                                | 77 |
| GENERAL VENTILATION . . . . .                                   | 77 |
| ISOLATION/SEPARATION . . . . .                                  | 79 |
| WORK PRACTICES . . . . .  | 79 |
| Load Transfer . . . . .   | 79 |

CONTENTS (continued)

|  |    |
|--|----|
| Air Out Chamber Before Cleaning . . . . .  | 81 |
| CONCLUSIONS . . . . .  | 82 |
| CYCLE MODIFICATIONS . . . . .  | 82 |
| STERILIZER DOOR VENTILATION . . . . .  | 82 |
| VENTILATED AIR GAP ENCLOSURE . . . . .   | 83 |
| SINGLE-DOSE CARTRIDGE STERILIZERS . . . . .  | 83 |
| Eto DISCHARGE LOCATION . . . . .   | 83 |
| STERILIZER ISOLATION ROOMS . . . . .   | 83 |
| MECHANICAL ACCESS ROOM/STERILIZER CABINET VENTILATION . . . . .                        | 83 |
| SUPPLY CYLINDERS . . . . .   | 84 |
| RELIEF VALVE . . . . .   | 84 |
| DEDICATED EXHAUST . . . . .  | 84 |
| VENTILATION ALARMS . . . . .   | 84 |
| GENERAL VENTILATION . . . . .  | 84 |
| WORK PRACTICES . . . . .   | 86 |
| Eto ALARMS . . . . .   | 86 |
| EMERGENCY PROCEDURES . . . . .   | 86 |
| ROUTINE MONITORING . . . . .   | 86 |
| RECOMMENDATIONS . . . . .  | 87 |
| EXPOSURE SOURCES AND SPECIFIC CONTROL METHODS . . . . .                                | 87 |
| Sterilizer Area . . . . .  | 87 |
| Exposure Source . . . . .  | 87 |
| Control Methods . . . . .  | 87 |
| Operation of Sterilizers . . . . .   | 87 |
| Supply Cylinders . . . . .   | 87 |
| Exposure source . . . . .  | 87 |
| Control methods . . . . .  | 89 |
| Newly Sterilized Loads . . . . .   | 89 |
| Exposure sources . . . . .   | 89 |
| Control methods . . . . .  | 89 |
| Ventilation . . . . .  | 90 |
| Dedicated Exhaust System . . . . .   | 90 |
| Exposure sources . . . . .   | 90 |
| Control methods . . . . .  | 90 |
| Local Exhaust for Sterilizer Door . . . . .  | 90 |
| Exposure source . . . . .  | 90 |
| Control method . . . . .   | 90 |
| Ventilation Systems for Sterilizer Enclosures and Mechanical<br>Access Rooms . . . . . | 91 |
| Exposure sources . . . . .   | 91 |
| Control methods . . . . .  | 91 |
| Waste Discharges . . . . .   | 91 |
| Discharges From Buildings . . . . .  | 91 |
| Exposure source . . . . .  | 91 |
| Control method . . . . .   | 92 |
| Vacuum Pump and Sewer Drain Discharges . . . . .                                       | 92 |
| Exposure sources . . . . .   | 92 |
| Control methods . . . . .  | 92 |
| Discharge Line From a Single-Dose Cartridge Sterilizer . . . . .                       | 92 |
| Exposure source . . . . .  | 92 |
| Control methods . . . . .  | 92 |



CONTENTS (continued)

|  |     |
|--|-----|
| Discharges From Sterilizer Pressure-Relief Valve . . . . . | 92  |
| Exposure source . . . . .                                  | 92  |
| Control methods . . . . .                                  | 92  |
| Accidental Releases . . . . .                              | 93  |
| Exposure Sources . . . . .                                 | 93  |
| Control Methods . . . . .                                  | 93  |
| GENERAL CONTROL METHODS . . . . .                          | 93  |
| Maintenance . . . . .                                      | 93  |
| Monitoring . . . . .                                       | 94  |
| Conventional Air Sampling . . . . .                        | 94  |
| Sampling methods . . . . .                                 | 94  |
| Sampling strategies . . . . .                              | 94  |
| Real-Time Monitoring Devices . . . . .                     | 94  |
| Equipment-function sensors . . . . .                       | 94  |
| Environmental sensors . . . . .                            | 95  |
| Respiratory Protection . . . . .                           | 95  |
| Labeling and Posting of Hazards . . . . .                  | 95  |
| REFERENCES . . . . .                                       | 98  |
| APPENDIX A: . . . . .                                      | 104 |
| APPENDIX B: Hazard and Operability Study . . . . .         | 119 |
| APPENDIX C: . . . . .                                      | 165 |
| GLOSSARY . . . . .   | 166 |

FIGURES

|   |    |
|---|----|
| 1. Typical cycle for a 12:88 sterilizer drawing two deep vacuum purges followed by one or more closed-door air flush periods . . . . .                            | 12 |
| 2. Typical cycle for a 12:88 sterilizer drawing "pulsating" purges . . . . .  | 13 |
| 3. Typical cycle for a 100 percent EtO sterilizer . . . . .   | 14 |
| 4. Hypothetical sampling periods, each containing the same exposure peak, have different average concentrations but the same concentration-time product . . . . . | 42 |
| 5. The number of detected full-shift charcoal tube samples in the ppm range for sterilizer operators . . . . .  | 45 |
| 6. The number of detected full-shift charcoal tube samples in the ppm range for the area in front of the sterilizers . . . . .                                    | 46 |
| 7. The number of detected full-shift charcoal tube samples in the ppm range for other workers . . . . .   | 47 |
| 8. The number of detected full-shift charcoal tube samples in the ppm range at the other area locations . . . . .   | 48 |
| 9. The number of detected short-term charcoal tube samples in the ppm-min for sterilizer operators . . . . .  | 49 |
| 10. The number of detected short-term charcoal tube samples in the ppm-min range for the area in front of the sterilizers . . . . .                               | 50 |
| 11. The number of detected short-term charcoal tube samples in the ppm-min range for sterilizer operators during load transfer only . . . . .                     | 52 |
| 12. The number of detected short-term samples in the ppm-min range for the area in front of the sterilizers (determined by portable gas chromatograph) . . . . .  | 53 |

CONTENTS (continued)

|     |  |    |
|-----|--|----|
| 13. | The number of detected samples in the ppm range for the concentration in the sterilizer when the door was opened to remove the load (determined by portable gas chromatograph) . . . . . | 54 |
| 14. | Representative infrared analyzer responses . . . . .   | 57 |
| 15. | Hot air escaping from a partially opened sterilizer door . . . . .   | 68 |
| 16. | Slot hood used to capture the EtO escaping from the chamber during the door-cracked period . . . . .   | 69 |
| 17. | A canopy hood used to exhaust the EtO which rises in front of the sterilizer during the door-cracked period . . . . .  | 71 |
| 18. | A recommended hood design for EtO cylinders . . . . .  | 75 |
| 19. | Gas-cylinder-supplied EtO sterilizer with isolated loading area and mechanical access room . . . . .   | 88 |

TABLES

|     |  |    |
|-----|--|----|
| 1.  | Ventilation standards . . . . .  | 27 |
| 2.  | Sampling frequencies recommended by OSHA . . . . .   | 31 |
| 3.  | Control characteristics for sterilizers surveyed in this study . . . . .   | 34 |
| 4.  | Sampling strategy . . . . .  | 36 |
| 5.  | Charcoal tube samples below the limit of detection . . . . .   | 44 |
| 6.  | Results of selected nonroutine gas bag samples . . . . .   | 55 |
| 7.  | Results from the infrared analyzer tracings . . . . .  | 58 |
| 8.  | Summary of local exhaust ventilation values . . . . .  | 59 |
| 9.  | Summary of general ventilation values . . . . .  | 60 |
| 10. | Summary of work practice parameters . . . . .  | 62 |
| 11. | Comparison of the operator's short-term exposure-dose to the chamber concentration when the door is opened to remove the load . . . . .  | 64 |
| 12. | Sterilizer discharge line/drain controls . . . . .   | 73 |
| 13. | Comparison of full-shift operator's exposures and area concentrations in front of the sterilizer with the ratio of the ventilation volume per hour to the room volume . . . . .  | 78 |
| 14. | The relationship of the presence of a sterilizer isolation room and the chamber concentration when the door was opened for the load transfer to the ratio of the sterilizer operator's ambient exposure to the sterilizer area ambient concentration . . . . . | 80 |
| 15. | Typical ventilation rates found to be effective for access rooms . . . . .   | 85 |
| 16. | NIOSH recommended respiratory protection for EtO . . . . .   | 96 |

#### ACKNOWLEDGMENTS

The authors wish to express their gratitude to all the health-care workers, sterilizer manufacturer representatives, and others who gave freely of their time and knowledge when called on. The authors wish to specifically thank the following coworkers among the many who assisted in this project: Alfred Amendola under whose guidance this study was completed, William Todd for his help on all the surveys and his artwork during the study, and Dennis O'Brien for his invaluable contributions during every phase of the project. Finally, this document is dedicated to the remembrance of John Frede, whose efforts in preparing equipment and samples, and performing innumerable other tasks involved in the conduct of field surveys, made the successful completion of those surveys possible.



## INTRODUCTION

Ethylene oxide (EtO) is a currently indispensable sterilant for certain medical items in health-care facilities. However, in addition to being bactericidal, it is also potentially hazardous to workers. Acute exposures may cause irritation of the eyes, nose, and throat, burns of the skin, and allergic sensitization.<sup>1</sup> Animal toxicity studies have shown EtO to be a mutagen and a carcinogen,<sup>2</sup> which may have implications for chronic, low-level exposures. Some studies of exposed workers have indicated increased mutagenic activity in human cells, and an increase in the incidence of leukemia and adverse reproductive effects.<sup>3</sup>

Much information on EtO is available from many sources; but no comprehensive study had been done on EtO emissions from hospital sterilizers and the control of hospital worker exposures. Many recommendations have been based on anecdotal observations, rather than conclusions drawn from industrial hygiene sampling and engineering measurements made in a connected series of surveys. This study was designed to assess the relative importance of the various EtO emission sources associated with gas sterilizers, and to determine, to the extent possible, the effectiveness of certain control measures on limiting health-care worker exposure to EtO.

## THE NEED FOR CONTROLS

Although less than 2 percent of all EtO produced in the United States is used as a sterilant (most of it is used in the chemical industry),<sup>4,5</sup> this small usage probably results in most of the employee exposures to EtO.<sup>6</sup> The Occupational Safety and Health Administration (OSHA) has reported that EtO is used as a sterilant in 7,700 sterilizers in 6,300 hospitals.<sup>7</sup> It has been estimated that approximately 75,000 U.S. health-care workers employed in sterilization operations are potentially exposed to EtO, and an additional 25,000 other employees working in adjacent areas may be incidentally exposed because inadequate control measures allow the spread of EtO.<sup>4</sup>

Hospitals and other health-care facilities routinely use EtO as an agent to sterilize medical devices and equipment. Its use is especially important in the sterilization of heat-sensitive items which cannot be sterilized by steam. There is no suitable substitute at the present time for EtO sterilization within hospitals, and, therefore, controlling exposures by other means is essential.

### ETHYLENE OXIDE - BACKGROUND AND STERILIZATION CHARACTERISTICS

Chemically, EtO ( $C_2H_4O$ ) is a polar molecule with a molecular weight of 44. At atmospheric pressure EtO has a boiling point of 5.3°F (10.7°C); and, thus, it is a liquid in cartridges and cylinders, but a gas in the sterilizer and in the workroom atmosphere. At standard temperature and pressure, the vapor density of EtO is 1.5. Ethylene oxide is flammable in air at concentrations above 3 percent or 30,000 parts EtO per million parts of air (ppm), and has a relatively high odor threshold of about 700 ppm.<sup>1</sup> EtO is soluble in water, organic solvents, and some organic solids; and it readily diffuses and penetrates most materials.

EtO was first used as a fumigant and pesticide early in this century. In 1929 its bactericidal properties were recognized by H. Schrader and E. Bossert.<sup>9</sup> A "Method of Sterilization" using EtO was patented by P. M. Gross and L. F. Dixon in 1937. C. L. Griffith and L. A. Hall patented a sterilization process using EtO in 1940 and 1943.<sup>8</sup> Existing steam autoclaves were used to first draw a vacuum on the chamber, then pure EtO was injected to sterilize the items. Beginning in 1949, C. R. Phillips and S. Kaye published a series of articles defining the four parameters necessary for EtO sterilization.<sup>9</sup> With the introduction of commercially available automatic equipment, EtO sterilization gained general acceptance in hospitals and industry. As medical technology advanced, the number of items which could not be sterilized with steam (plastics, rubber, drills, and implants) also grew, thereby increasing the need for EtO sterilization.

Four parameters affect the ability of EtO to sterilize products: temperature, concentration, humidity, and time. Most routine hospital sterilization is done at 120 to 140°F, however, sterilization of particularly heat-sensitive items can be performed at 100 to 105°F. Research has determined that 450 mg/liter is the minimum EtO concentration necessary for sterility. To be sure there is enough EtO, most sterilizers use EtO concentrations of 600 to 1,100 mg/liter. The proper amount of humidity is necessary for the sterilization to be effective. The amount of time required for sterilization depends on the temperature, taking less than 2 hours at approximately 130°F and over 5 hours at approximately 100°F.<sup>9</sup>

Because EtO is absorbed into the materials, an appropriate aeration time is required to allow the residual EtO to be released. Standard use items require 12 hours at 120°F. Implants and specialty items require longer aeration periods, and the manufacturer's instructions are followed.

Gas sterilizers have changed much in the past few years. A variety of emissions controls have been developed as more has been learned about the hazards of EtO.

#### ETHYLENE OXIDE TOXICITY

Ethylene oxide is a toxic chemical with acute and chronic health effects. EtO is a carcinogen in animals and a suspected carcinogen in humans.<sup>3,6,10</sup> It is an established mutagen in animal test systems and is associated with chromosomal aberrations and sister chromatid exchanges in humans.<sup>2,11,12</sup> Adverse reproductive effects, such as fetotoxicity and dominant-lethal mutation, have been demonstrated in several animal species,<sup>6,13,14</sup> and EtO exposure has been linked to spontaneous abortions and gynecological disorders in humans.<sup>15,16</sup> Additional evidence is now available which suggests that EtO exhibits a dose-rate effect.<sup>17</sup> This section summarizes many of the major toxicological investigations of EtO.

#### Acute Health Effects

Inhalation exposure to very high concentrations of EtO (600 ppm for 8 hours or 6,000 ppm for 12 minutes) is likely to result in severe injury or death. Individual response to particular exposure levels will vary. Immediate effects include watering eyes, salivation, nasal discharge, and shortness of breath. Exposure to more than a few hundred ppm for more than a few hours may include such delayed effects as: nausea, vomiting, diarrhea, convulsions, headache, drowsiness, dizziness, bronchitis, cardiac abnormalities, and possible death from secondary lung infection or systemic poisoning. Exposure to higher concentrations of more than a few thousand ppm for more than a few hours may cause death from fluid collecting in the lungs.<sup>1</sup> Exact exposure values for the onset of specific health effects in humans are not known because experiments have not been conducted on people and the values must be estimated from animal data.

Dermal exposure to concentrated liquid EtO may result in sensitization, edema, and frostbite. Dilute aqueous solutions of EtO may produce chemical burns and blisters. A small quantity of moisture may increase the irritant effects of

EtO, but copious rinsing of exposed skin is recommended if EtO comes in contact with the skin.<sup>1</sup>

### Carcinogenicity

The potential carcinogenicity of EtO was not evident until the mid- to late-1970's. Since then, several important studies have established EtO as a carcinogen in animals.

A 2-year chronic inhalation bioassay study was conducted at the Bushy Run Research Center with male and female Fischer 344 rats exposed to EtO at concentrations of 10, 33, or 100 ppm for 6 hours per day, 5 days per week. The study reported a dose-related increase in the incidence of mononuclear cell leukemia for the exposed female rats. Exposed males experienced a dose-related increase in peritoneal mesotheliomas. A dose-related increase in cerebral gliomas was reported in both exposed males and females.<sup>13</sup>

NIOSH also conducted a 2-year inhalation study (Lynch et al.<sup>18</sup>) with male Fischer 344 rats and Cynomolgus monkeys, with exposures to EtO at concentrations of 50 or 100 ppm for 7 hours per day, 5 days per week. There was also a control group which received no experimental exposure to EtO. The NIOSH study confirmed the findings of the Bushy Run study, reporting dose-related increases in the incidence of mononuclear cell leukemia, peritoneal mesothelioma, and cerebral glioma in the exposed rats.

Intragastric administration of EtO to female Sprague-Dawley rats was performed by Dunkelberg during a 3-year study.<sup>19</sup> A dose-dependent increase in the incidence of squamous cell carcinomas of the forestomach was reported.

Hogstedt et al. have studied Swedish workers exposed to EtO.<sup>20</sup> In 1979, he reported 3 cases of leukemia in 230 workers in a factory sterilizing hospital equipment; the expected leukemia rate was 0.2 cases based on Swedish national statistics. Exposures were estimated to have been less than 30 ppm TWA.

Hogstedt et al. reported, also in 1979, significant increases in the mortality of workers in an EtO production plant.<sup>21</sup> The workers had at least 1 year of exposure to EtO and had worked in the plant for at least 10 years. Compared with Swedish national rates, the workers experienced 9 cases of stomach cancer where 3.4 were expected, 2 cases of leukemia with an expected rate of 0.14, and 12 cases of circulatory system disease with 6.3 cases expected. Similar increased mortality was observed for production workers with at least 10 years exposure to EtO and 20 years since first exposure.

In 1986, Hogstedt reported on a follow-up of the first two studies.<sup>22</sup> In the 733 workers, 8 cases of leukemia had occurred with 0.8 expected, and 6 cases of stomach cancer were reported with 0.65 cases expected, again based on Swedish national statistics. Workers were estimated to have been exposed to low EtO concentrations.

Morgan et al. reported a study of EtO exposed workers in a chemical production plant with no indication of increased leukemia mortality.<sup>23</sup> The study population was small, and based on national statistics, the expected leukemia



rate was 0.14. The authors indicated their study would have detected only a greater than 10-fold increase in the risk of leukemia. The study reported a significant increase in pancreatic cancer and Hodgkin's disease.

Based on the animal and human studies, both NIOSH and OSHA concluded that EtO is a carcinogen in animals and increases the risk of cancer deaths in humans.<sup>6,10</sup>

#### Mutagenicity and Cytogenicity

Ethylene oxide is an alkylating agent and causes mutation of cells and/or chromosomes. EtO is a mutagen in all microbial and plant test systems and in submammalian test systems tested so far, including barley, rice, wheat, viruses, Tradescantia, Salmonella typhimurium, Escherichia coli, Neurospora crassa, and Drosophila melanogaster.<sup>2</sup> EtO has also been shown to be mutagenic in mice, rabbits, and monkeys.

Generoso *et al.* reported the results of two studies in which male mice were injected intraperitoneally with EtO.<sup>24</sup> The first group was injected with 150 mg/kg EtO (maximum tolerated dose) then caged with female mice for 22 days. The second group was injected with either 30 or 60 mg/kg EtO for 5 days per week for 5 weeks, then caged with 3 female mice for 1 week. Dominant-lethal effects were observed in both groups, and a dose-related increase in the occurrence of heritable translocations was reported for the male offspring of exposed mice.

The NIOSH 2-year inhalation study with *Cynomolgus* monkeys exposed to 50 or 100 ppm for 7 hours per day, 5 days per week showed an increased frequency of chromosomal aberrations in peripheral lymphocytes and an increase in sister chromatid exchanges.<sup>18</sup> Yager and Benz reported a dose-related increase in sister chromatid exchanges in peripheral lymphocytes for New Zealand white rabbits exposed to EtO in an inhalation study in which rabbits were either not exposed (control group) or exposed to 10, 50, or 250 ppm for 6 hours per day, 5 days per week for 12 weeks.<sup>26</sup>

Studies of humans exposed to EtO concur with the results of animal studies. Abrahams reported a study of workers exposed to EtO in the manufacture and distribution of health-care products.<sup>11</sup> Exposure data indicated that workers were exposed to less than 50 ppm TWA (the OSHA PEL at the time), but that occasionally the 75 ppm short-term limit recommended by NIOSH had been exceeded. Results of the study showed an increase in chromosomal aberrations in peripheral lymphocytes and an increase in sister chromatid exchanges in the exposed workers.

In an extensive study of its workers, Johnson and Johnson found chromosomal aberrations and sister chromatid exchanges in workers exposed to 1 to 10 ppm EtO TWA.<sup>6</sup> One group of workers characterized by high exposures, 5 to 200 ppm, evidenced a persistent high rate of sister chromatid exchanges even after cessation of exposure.

Yager *et al.* studied a small group (14 workers) of hospital sterilizer operators.<sup>12</sup> Short-term exposures averaged 82 ppm over 3.5 minutes. The

workers exhibited an exposure related increase in the frequency of sister chromatid exchanges which was correlated with both EtO exposure and smoking.

### Reproductive Effects

The reproductive effects of EtO have been studied in animals and to a lesser extent in humans. Ethylene oxide has been shown to decrease fertility and to cause malformed fetuses when administered at specific times during gestation in rats and mice. NIOSH studies demonstrated that EtO exposure adversely affected the sperm counts of monkeys.<sup>25</sup> Studies of humans have not been definitive, but increased spontaneous abortions and gynecological disorders have been indicated.

Snelling et al. exposed male and female Fischer 344 rats to 10, 33, 100 ppm EtO in air for 6 hours per day, 5 days per week for 12 weeks, and for 6 hours per day, 7 days per week during a 2-week mating period.<sup>13</sup> Females were then exposed per the latter regimen for days 0-19 of gestation. No effects were observed in the dams or litters of the groups exposed at 10 or 33 ppm. In the group exposed to 100 ppm, decreases in pups per liter and the number of implantation sites were statistically significant. In the same exposure group, the percentage of pregnant females and the percentage of males proven fertile were also lower than for unexposed controls.

LaBorde and Kimmel reported results of intravenous administration of EtO to CD-1 mice.<sup>14</sup> Pregnant mice received doses of 75 or 150 mg/kg once during gestation, either days 4-6, days 6-8, days 8-10, or days 10-12. All exposure groups experienced a reduction in mean fetal weight. Exposure groups for days 6-8 and days 10-12 experienced an increase in the number of malformed fetuses per litter. Defects in the thoracic and cervical skeleton were the most common.

Hardin et al. conducted a study of EtO teratogenicity in Sprague-Dawley rats and New Zealand white rabbits.<sup>27</sup> Both rats and rabbits were exposed to a concentration of 150 ppm EtO for 7 hours per day. Four groups experienced different exposure regimens ranging from a control group with no exposure to a group exposed to EtO for 3 weeks prior to breeding and on each day of gestation. Rats evidenced embryo and fetal toxicity as well as an increase in the incidence of reduced skeletal ossification. The study did not detect evidence of embryo or fetal toxicity or developmental defects in exposed rabbits.

In the NIOSH inhalation study, Lynch et al. reported that cynomolgus monkeys, exposed to 50 or 100 ppm EtO for 7 hours per day, 5 days per week, for 2 years experienced decreased sperm counts and decreased sperm motility.<sup>25</sup> However, there was no increase in the percentage of morphologically abnormal sperm nor were any adverse effects noticed in the control group.

Other studies have evaluated rabbits, rats, and mice with varying exposure regimens. OSHA concluded that EtO in doses which produce maternal toxicity is fetotoxic in rabbits, mice and rats, and teratogenic in mice when exposure occurs during gestation.<sup>6</sup> At lower doses, EtO is fetotoxic in rats when both sexes have been exposed prior to and during gestation, and when females

are exposed during gestation. EtO induces dominant-lethal effects in several species, and effects sperm counts and sperm motility in monkeys.

Studies of human reproduction are very difficult and complex. Hemminki *et al.* conducted a retrospective study of hospital sterilizing personnel in Finland. Women exposed to EtO during sterilization operations from 1951 to 1981 were evaluated for occurrence of spontaneous abortions and compared to other members of the sterilizing staff and other hospital personnel who were not knowingly exposed to EtO in the course of their work.<sup>15</sup>

No exposure data were available prior to 1976. Exposures for the 25 years prior to 1976 were estimated to be the same as the conditions in that year. Most workers seemed to have been exposed only once or twice per day with short-term peak exposures of 20 ppm or more. Hemminki found the rate of spontaneous abortion for the exposed sterilizing staff to be significantly higher than the unexposed hospital personnel. Hemminki's methodology has been criticized; however, NIOSH concluded the results are suggestive of adverse effects on human reproduction and cannot be discounted.<sup>10</sup>

A study conducted by Yakubova *et al.* in the Soviet Union reported on gynecological disorders of women working in EtO production plants.<sup>16</sup> The exposed workers experienced an increased incidence of gynecological disorders primarily diseases of the cervix and uterus. Exposed workers also had an increased frequency of spontaneous abortion and toxemia.

#### Dose-Rate Effect

When Generoso *et al.* exposed male mice for 4 days at 600 ppm per day for 3 hours, 3 times as many offspring died as for those exposed at 300 ppm for 6 hours; and at 1,200 ppm for 1.5 hours, 6 times as many died.<sup>17</sup> Although the exposure levels were at much higher concentrations than typically encountered in the workplace, it is clear the study shows a dose-rate effect for EtO. Such an effect raises additional concerns about short-term exposures above recommended limits, even if the full-shift TWA exposure limits are met.

#### Conclusions

Based on the available EtO toxicity information, NIOSH and OSHA have concluded: (1) EtO is a carcinogen in animals and represents a significant cancer risk for exposed humans, (2) EtO is a mutagen in animals and affects human DNA, and (3) EtO adversely affects animal reproduction and evidence suggests that human reproduction may also be adversely affected.<sup>6,10</sup>

#### EXPOSURE LIMITS

In 1971, OSHA set the permissible exposure limit (PEL) at 50 ppm for an 8-hour time-weighted average exposure.<sup>6</sup> The PEL was based on the 1968 American Conference of Governmental Industrial Hygienists, ACGIH, threshold limit value, TLV.<sup>28</sup> The TLV had been established on the basis of a limited animal inhalation study showing no adverse effects from exposures less than 50 ppm. No indications of the carcinogenicity of EtO were available.

NIOSH conducted a special occupational hazard review in 1977 and recommended an exposure ceiling limit of 75 ppm (15 minutes) in addition to the 50 ppm PEL.<sup>4</sup> NIOSH reported on several studies of EtO's potential as a mutagen and the chemical bonding of EtO with DNA. At that time, no data were available on EtO's carcinogenicity.

In 1979, ACGIH issued a notice of intended change (adopted in 1981) to lower the TLV for EtO from 50 ppm to 10 ppm, 8-hour TWA.<sup>29</sup> This action was based on the growing number of in vitro studies reporting mutagenic responses to EtO exposure and to Hogstedt's studies in Sweden.

NIOSH issued Current Intelligence Bulletin #35 in 1981 which reviewed the growing body of literature on the mutagenic, carcinogenic, and reproductive effects of EtO exposure.<sup>2</sup> NIOSH recommended that the OSHA standard be reevaluated. Also in 1981, ACGIH proposed a reduction in the TLV from 10 ppm to 5 ppm and listed EtO as a suspected carcinogen based on the results of the Bushy Run study.<sup>30</sup>

In 1982, ACGIH proposed to further reduce the TLV to 1 ppm (adopted in 1984).<sup>31</sup> Also in that year, OSHA announced its intent to reevaluate the standard and began the formal promulgation process.<sup>7</sup>

OSHA developed a risk assessment and conducted hearings on EtO in 1983. Based on an estimated 60,000 hospital workers exposed to EtO over a 45-year employment period, OSHA estimated that 3,800 to 6,500 excess deaths could be expected at the 50 ppm PEL. For the proposed 1 ppm PEL, OSHA estimated 72 to 138 excess deaths could be expected.<sup>6</sup> NIOSH testified that it considered the risk imposed by exposure to EtO even at the 0.1 ppm level to be too great, and that exposures "should be reduced through engineering controls to the lowest feasible level." NIOSH recommended to OSHA that a ceiling limit of 5 ppm should be established and not be achieved for more than 10 minutes in any working day, and that the PEL should be set less than 0.1 ppm.<sup>10</sup>

In June 1984, OSHA issued the new standard PEL of 1 ppm, 8-hour TWA.<sup>6</sup> However, the inclusion of a short-term exposure limit (STEL) became a matter of contention. In early 1985, OSHA announced its decision not to establish a STEL.<sup>32</sup> Later that year, Generoso et al. reported a study of male mice exposed to very high concentrations of EtO during short time periods.<sup>17</sup> The results showed an increase in dominant-lethal response with an increase in dose rate. J. Donald Millar, NIOSH Director, is quoted as saying the study's results "strengthen our previous conviction" that a short-term limit is needed.<sup>33</sup> In July 1986, the U.S. Court of Appeals for the District of Columbia Circuit ordered OSHA to either adopt a STEL or explain why it's interpretation of the evidence on exposure patterns resulted in terming a STEL "irrelevant" in controlling TWA exposures.<sup>34</sup> In April 1988, OSHA amended its existing standard for occupational exposure to ethylene oxide (29 CFR 1910.1047) by adopting an excursion limit for EtO of 5 ppm averaged over a sampling period of 15 minutes.<sup>35</sup>

## Potential for Overexposure

Small amounts of EtO can cause significant exposures. For example, 1 gram of EtO can initially create a concentration of over 20 ppm in a room approximately 10 by 10 feet with an 8-foot ceiling. Even after being diluted with supposedly adequate general room ventilation for 8 hours, this single gram could cause an average exposure of approximately 1 ppm. Most of the single-dose cartridges now being used in table-top sterilizers contain either 100 or 134 grams of EtO. An 8.8-ft<sup>3</sup> sterilizer which uses a mixture of 12 percent (by weight) ethylene oxide in dichlorodifluoromethane contains approximately 150 grams of EtO during sterilization. A typical large supply cylinder of the 12:88 gas mixture contains over 7,000 grams of EtO when full.

It does not take a supply-line rupture or some other catastrophic event to cause high concentrations of EtO. One overexposure situation (observed by NIOSH, but not part of this study) caused by inadequate ventilation was sufficient to elicit symptoms of acute exposure.<sup>36</sup> Because EtO cannot be detected by its odor until concentrations exceed approximately 700 ppm, it is possible for workers to be overexposed without knowing it. It seems imperative that adequate controls be instituted and that exposures be periodically monitored to make sure the controls are working.

## BASIS FOR CONTROL - PROCESSES AND EMISSION SOURCES

### HOSPITAL STERILIZATION

#### Department Description

Ethylene oxide sterilization of medical equipment and surgical items may occur in one or more medical departments such as surgery or respiratory therapy. The most common practice is to centralize all sterilization in one area. Typically, hospitals refer to this department as central service; supply, processing, and distribution; or sterile reprocessing. In this report, the term central service (CS) will be used.

The CS department usually had four functional areas: decontamination, preparation and packaging, sterilization, and storage. Physical layout depended on the size of the hospital. In the hospitals studied, decontamination was always performed in a separate room as an infection control measure. The other three activities were sometimes performed in separate rooms, sometimes all were in the same room, and some hospitals had a combination of separate and common rooms.

A variety of sterilizers and locations was encountered, including small table-top units, large freestanding sterilizers enclosed in a cabinet, and large sterilizers recessed in a mechanical access room. A few were located in small rooms isolated from the rest of the department. And, although most of the sterilizers surveyed in this study were in a CS department, one hospital had a sterilizer in the surgery department and two sterilizers in the respiratory therapy department.

Nine of the sterilizers discussed in this report used a gas mixture of 12 percent EtO by weight in dichlorodifluoromethane delivered to the sterilizer from cylinders. The other two sterilizers used small, single-use cartridges of pure EtO. None of the sterilizers which use the glass ampoules of liquid EtO were surveyed in this study, because our walk-through surveys suggested that they represent a relatively small segment of installed sterilizers.

The number of workers in the sterilization departments of the surveyed hospitals ranged from four to ten, depending on the size of the hospital. Usually, one worker on each shift was responsible for operating both the steam and EtO sterilizers, one or two workers prepared and packaged the clean items, and one or two workers were assigned to decontaminate incoming soiled items. The sterilizer operator also assisted in the preparation and packaging of items when not operating the sterilizers. Duties were assigned on a rotating basis; and, depending on the number available, some workers might perform more than one, perhaps even all, of the mentioned tasks. Most of the workers were assigned to the day shift. Most of the hospitals ran a load during the latter

part of the day shift, so that the purge phase and transfer to the aerator would occur during the evening shift when fewer workers were present, yet not too late so that the load would be ready to be removed from the aerator when the day-shift workers arrived the next morning.

#### Process Description

Although practices varied from one hospital to another, the typical process started with the items arriving in the decontamination area. Here the items were cleaned, washed, and dried. The instruments were inspected and usually reassembled before being packaged.

For the heat-sensitive equipment and other items destined for gas sterilization, the items were packaged in special paperbacked polyethylene bags which were heat-sealed or wrapped in linen cloths and sealed with an EtO exposure indicator tape. The packaged items were then arranged on cart-racks or in baskets by the sterilizer operator and recorded on a sterilization log sheet. A biological indicator (BI) was placed in the load to provide quality assurance that sterilization had been achieved.

The sterilizer operator prepared the sterilizer, set the operating temperature, and checked the cycle pressure chart. Next, the load was inserted into the sterilizer chamber. This was either done by rolling a wheeled rack off a special cart, setting baskets on shelves fitted inside the chamber, or, in a few instances, placing individual items on the shelves. For the sterilizers which used the single-use cartridges, EtO, the operator placed the EtO gas cartridge inside the receptacle in the chamber then closed the door.

With the door securely closed, the cycle began. Cycle parameters varied depending on the items to be sterilized, the particular sterilizer, and any controls which had been added. The basic sterilization cycle was common to all of the sterilizers studied: initial chamber evacuation and humidification, charging the chamber with EtO, dwell period during which the actual sterilization took place, and chamber evacuation. Figures 1 to 3 illustrate the pressure and time relationships of the sterilizer cycles of interest. Most loads were sterilized at 130°F, and the dwell period was about 2-1/2 hours. Some items were particularly heat sensitive and were sterilized at 100°F with a dwell period of about 5 hours.

For all sterilizers, a buzzer indicated the completion of the basic cycle. At this point, one of three procedures were followed: (1) For the sterilizer with the in-chamber aeration feature, the operator simply allowed the cycle to continue uninterrupted to the aeration mode. (2) Some operators unloaded the sterilizer immediately and transferred the load to the aerator. (3) Other operators opened the sterilizer door a few inches and left the area for approximately 15 minutes before returning to unload the sterilizer. The latter practice is recommended by the manufacturers of the sterilizers studied and is known as the "door-cracked" period.

Once the door was fully opened, the load was removed from the sterilizer. Typically, the wheeled rack containing the sterilized goods is pulled from the

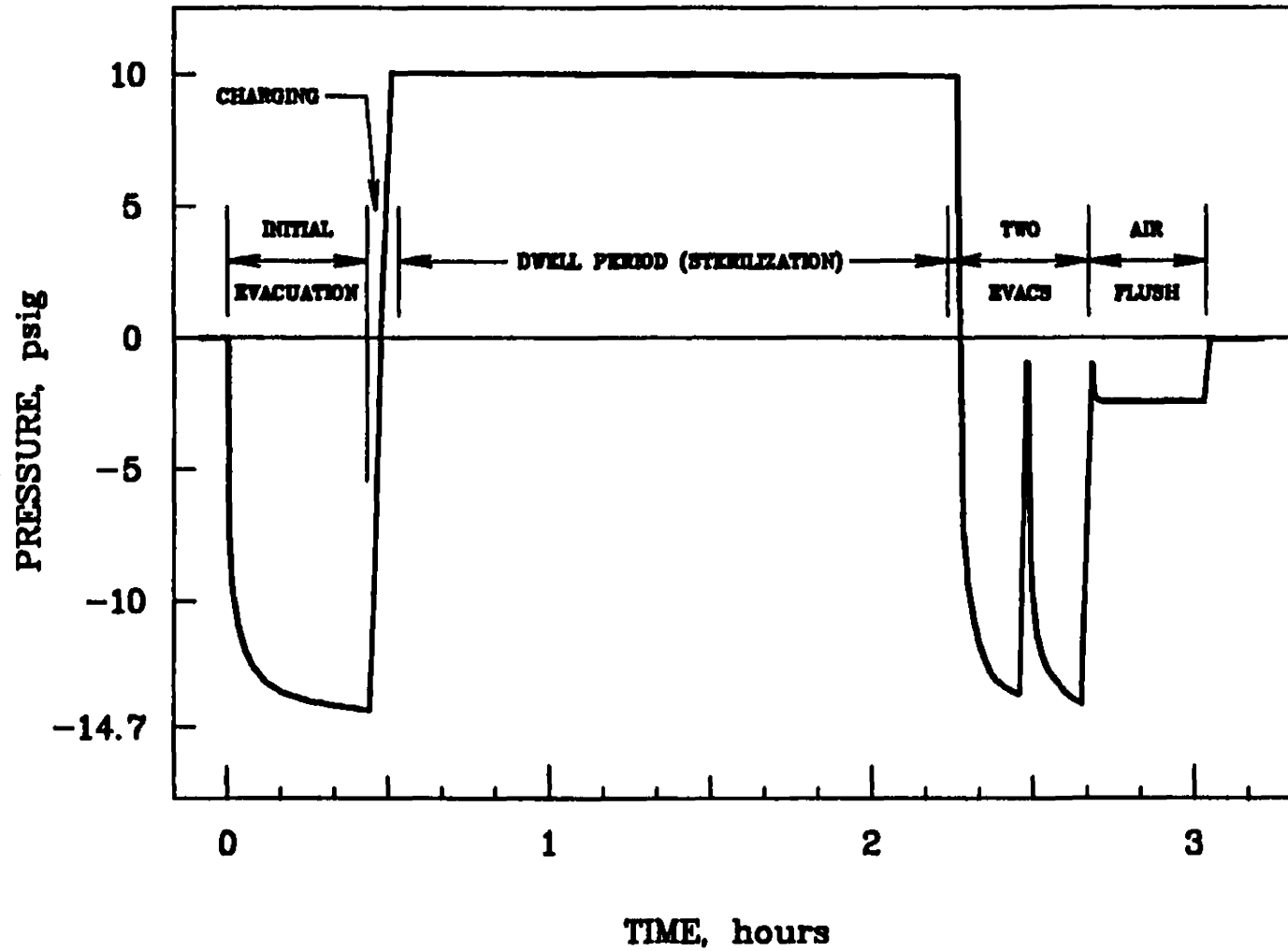

Figure 1. Typical cycle for a 12:88 sterilizer drawing two deep vacuum purges (approximately 0.9 atm) at the end of sterilization followed by one or more closed-door air flush periods.



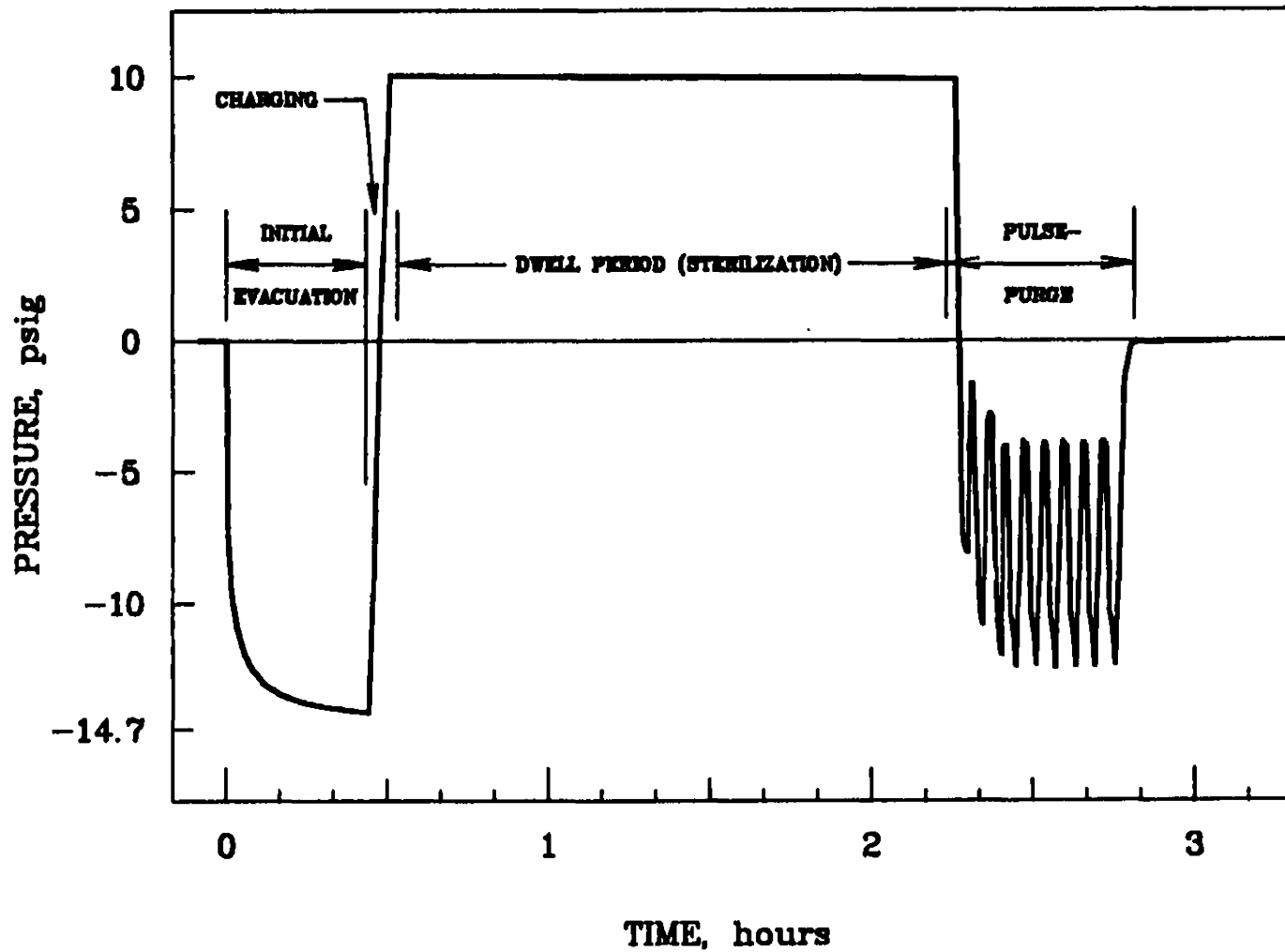

Figure 2. Typical cycle for a 12:88 sterilizer drawing "pulsating" purges (approximately 0.5 atm at a rate of 1 per minute) for a period of 30 minutes. For clarity of illustration, only nine pulses are shown in the 30-minute pulse purge period.

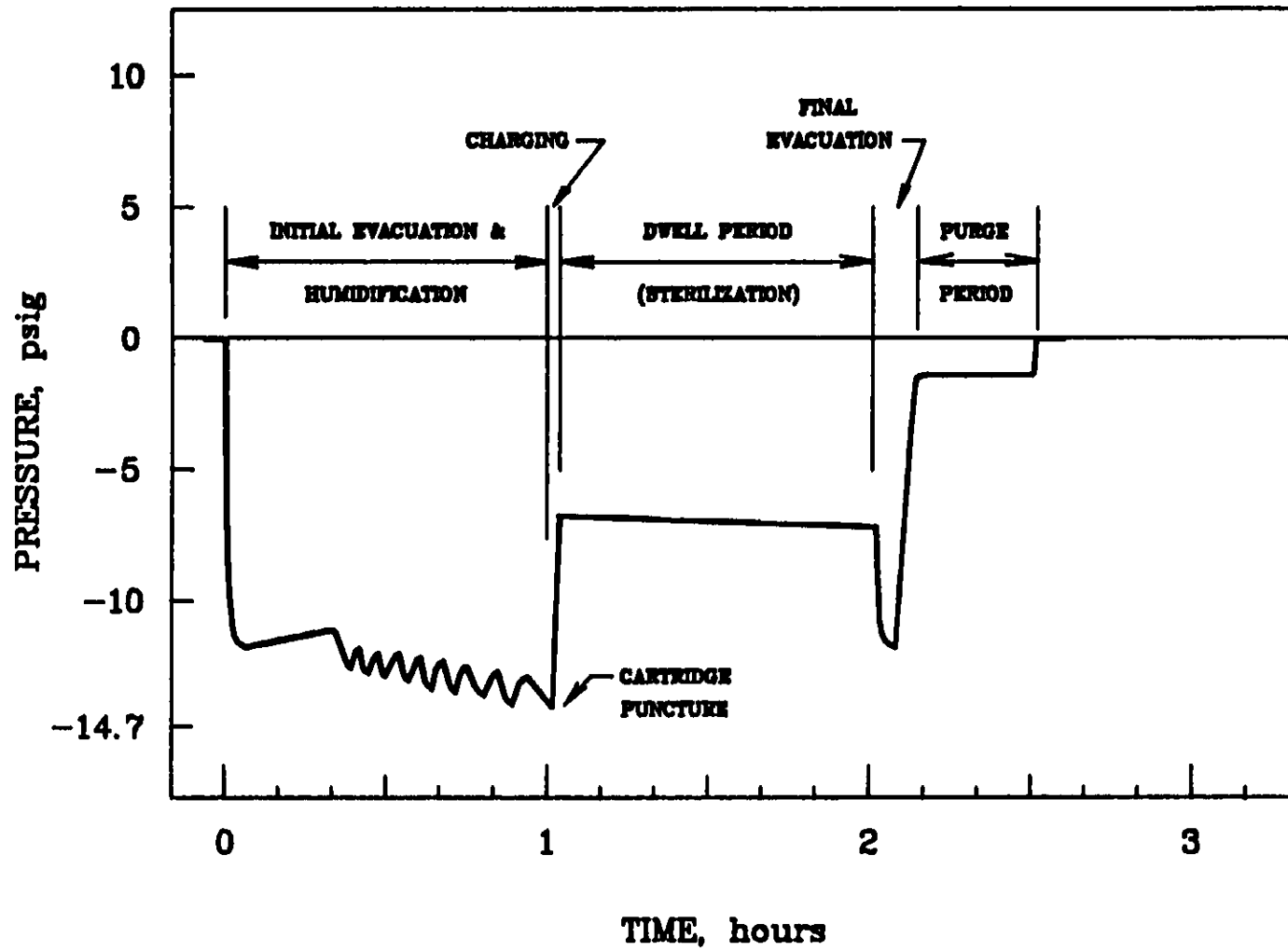

Figure 3. Typical cycle for a 100 percent EtO sterilizer showing a single vacuum draw (approximately 0.3 atm) followed by a closed-door fresh air purge period.

sterilizer onto a cart. The cart is rolled to the aerator, where the rack is pushed off of the cart into the aerator chamber. For departments using baskets to transfer items, the baskets were pulled off the shelves of the sterilizer chamber and carried to the aerator to be set on shelves. One hospital unloaded a cart-rack from the sterilizer, then manually placed baskets and some individual items on shelves in the aerator. Other than closing the aerator door, the final step was to record the date and time that aeration was started so it could be determined when the items could be removed from the aerator.

Two events were particularly variable, both from hospital to hospital and from operator to operator: the time at which the sterilizer door was closed after the load was removed, and the time at which the BI was removed from the sterile load. In some cases, the sterilizer door was closed before transferring the load to the aerator, and in other cases it was closed after the aerator door was closed. Similarly, usually the BI was pulled before the load was inserted into the aerator, but at other times, it was removed after aeration.

Generally the items were aerated approximately 12 hours at 120°F. When the aeration cycle was complete, the load was removed from the aerator. Sterile items were either stored on shelves in CS or returned to the using department.

#### ETHYLENE OXIDE EMISSION SOURCES

Ethylene oxide emission sources can be categorized into three groups: those with potential for creating immediately dangerous EtO exposures of a 1,000 ppm or more as the result of an accident or incident, those which might occasionally emit enough EtO to create exposures greater than 5 ppm, and those which may cause exposures of a few ppm or less.

#### Potential Release of Large Quantities of EtO

Three sources comprise the first group of infrequent but potentially hazardous emissions. First, the EtO supply container for the sterilizer, whether it is a large cylinder or a single-use cartridge, may release from one hundred to several thousand grams of EtO. The cylinders of the 12:88 mixture which a majority of hospitals use contain liquid under pressure and are connected through a valve to a supply line, another valve system, and the sterilizer chamber. Leaks or failure of any of the connections or the cylinders themselves could cause the contents of the entire cylinder to be discharged into the workroom atmosphere. It is known that EtO cylinders have leaked before being connected to the supply line and while in service, and that the entire contents of supply cylinders have been accidentally discharged due to human error. And even if the exposures in front of the sterilizer are controlled, the maintenance worker who changes the cylinder or supply line filters could be acutely exposed.

From the standpoint of occupational exposures, the cartridges of pure EtO are inherently safer due to the lack of external connections to the sterilizer and the much smaller quantity of EtO that they contain; the cartridge is punctured automatically after it is sealed inside the sterilizer and the cycle has

begun. However, if the cartridge were damaged accidentally or punctured outside the sterilizer, the quantity of EtO which it contains could create a dangerous concentration of EtO in the immediate area and department. The well in which the single-dose cartridge is located during sterilization was located outside the cabinet on early models of the single-dose cartridge sterilizers. With this configuration, workers could be sprayed with liquid EtO and/or exposed to the EtO vapor when the cartridge was punctured if it was not seated properly. The sterilizer manufacturer has recalled all sterilizers of this type and no longer supports their use.

The second potential source in this first group for releasing large quantities of EtO is the sterilizer itself, specifically the sterilizers using the 12:88 mixture. These sterilizers are pressurized to approximately 10 psig during the sterilization dwell period. Overpressurization of the chamber could result if the gas supply valve malfunctioned and was open when it was supposed to be closed. To counteract this, the chamber is fitted with an overpressure relief valve which could cause local concentrations of several hundred ppm in the indoor atmosphere if not properly vented, depending on the size of the sterilizer and the nature of the malfunction. The sterilizers which use the single-dose cartridge operate at a pressure below atmospheric throughout the entire cycle, and there is no relief valve.

Third, the sterilizer door gasket may develop leaks. This is especially true for the pressurized 12:88 sterilizers. Again, depending on the size of the sterilizer, the nature of the leak, and the effectiveness of the ventilation, local concentrations as high as several hundred ppm could develop.

The sterilizers which are supplied by single-dose cartridges are inherently less likely to leak EtO than the cylinder-supplied variety. Since they operate at negative pressure, if there were to be a door gasket leak, air would leak into the sterilizer chamber rather than EtO leaking out. However, the evacuation line carrying EtO downstream of the venturi is under pressure, and it is possible that it could be the source of an EtO leak.

#### Routine Sources Which May Cause High Concentrations

A second group consisting of three emission sources may account for most of the EtO released on an occasional basis. First, the sterilizer evacuation system for the 12:88 sterilizers depends on the evacuation of the EtO gas mixture through a water-sealed vacuum pump. At the discharge side of the pump, water and EtO are released to a sewer drain. Plumbing codes require an air gap between the discharge point of the vacuum pump and the sewer drain. Most of the EtO gas mixture from the chamber is released to the indoor atmosphere at this air gap. Depending on the control of the drain air gap, this may be the single most significant routine emission source.

Second, the opening of the sterilizer door at the completion of the cycle may provide the sterilizer operator with a very short high exposure followed by an increase in the workroom EtO concentration. In spite of the evacuation cycle, some EtO remains in the sterilizer and on the load. When the door is opened, this hot air containing EtO rises from the chamber. Without adequate local

exhaust ventilation, this EtO diffuses throughout the room, creating higher ambient concentrations for all workers in the department.

Third, the load transfer procedure provides the closest contact with EtO for the sterilizer operator: pulling the load from the sterilizer, transporting the load to the aerator, and inserting the load into the aerator. Residual EtO in the chamber and on the load may be released into the operator's breathing zone. Contact with the load may be prolonged by handling of baskets, individual items, and removal of the BI from the load.

#### Sources of Low Concentrations

A third group consisting of two emission sources may be responsible for EtO concentrations and exposures of a few ppm or less. The first source is opening the aerator door to retrieve items or to rearrange items on shelves to accommodate another load. This situation tends to occur mostly in departments with one aerator. In this case, production demands are such that the aerator must be used for loads with overlapping aerations times.

The second source involves cleaning the interior of the sterilizer chamber. This practice usually involves wiping the interior surface of the chamber with water. Often the worker must insert the head and upper body into the chamber in order to reach back surfaces. The sterilizer may retain EtO even after the load is removed, especially when the door is completely closed after each use. If cleaning is done soon after a load transfer, an elevated exposure could result.

## OVERVIEW OF CONTROL TECHNIQUES

Engineering controls, work practice modifications, and maintenance procedures to limit worker exposure to EtO are applied to the primary emission sources. Control techniques may include isolation, equipment modification, exhaust ventilation, work practices, protective equipment, and both routine personal and continuous area environmental monitoring. Substitution was not found to be a viable alternative in this study.

### SUBSTITUTION

Substitution of some other method which does not use EtO would eliminate the potential hazards from exposure to EtO. However, the substitute must perform satisfactorily to be acceptable, and it must be chosen carefully so that other, perhaps greater, hazards are not introduced into the workplace.

Steam is the preferred method for sterilizing certain medical items. However, a growing list of essential medical items cannot be subjected to the heat and moisture associated with steam sterilization.

Glaser listed a number of possible alternatives in the NIOSH Special Occupational Hazard Review;<sup>4</sup> and, in a later publication, he noted the evaluation of such alternative methods as gamma radiation, electron beam irradiation, and ultraviolet radiation as possible alternatives to EtO for certain applications. However, he also stated that hospitals have a present and future need for EtO sterilization, and he quoted from the April 1980 report of the Interagency Regulatory Liaison Group of the U.S. Government that, as of that date, there seemed to be no suitable alternative methods for sterilizing medical items and fumigating certain stored agricultural commodities.<sup>37</sup>

### ISOLATION

Separating workers from EtO emissions sources by a physical barrier or large distances is one method to reduce worker exposure. The separation, or isolation, is most needed for the sterilization operations which may have relatively high EtO levels associated with them. However, isolation of the aeration process is also recommended.

### Sterilization Operations

Glaser<sup>4</sup> and others<sup>38-43</sup> have recommended that sterilizer operations involving EtO should be isolated from all non-EtO work areas. Runnells suggested that the area be accessible only to sterilizing department personnel, and that the number of department personnel with direct access

should be restricted.<sup>42</sup> Halleck specified that the sterilizer should be located away from areas of heavy traffic.<sup>43</sup>

A common isolation technique is to recess the sterilizer (and aerator) in an equipment room so that the doors and the control panels are flush with the wall, and all of the mechanical components are behind the wall in the equipment room (mechanical access room). Often the EtO supply cylinders are also located in this room. When used in conjunction with local exhaust ventilation, this technique separates the workers from several potentially high EtO emission sources: the vacuum pump discharge line connection with the sewer drain, the overpressure relief valve, and the EtO supply cylinders.

Another option is to place the sterilizer (and aerator) in a separate room. This approach isolates several emissions sources from the workers during most of the shift. It also confines the EtO given off during the load transfer, preventing exposure to the other workers in the department. However, unless local exhaust ventilation is very carefully applied along with good work practices and controls for chamber concentrations, this method of isolation could serve to concentrate EtO emissions and thereby increase the operator's exposure during the load transfer.

#### Aeration

The Association for the Advancement of Medical Instrumentation (AAMI) has recommended that all sterilized items be aerated, preferably in an aeration cabinet designed for this function. Ambient aeration, at room temperature, even in a specified room or area, is a poor method which may eventually present problems with chronic exposure.<sup>39</sup>

Churinetz et al. described an aeration tunnel in an industrial facility through which the pallets of sterilized products move without human contact during the aeration process.<sup>44</sup> No such system is known to exist in a hospital; however, three of the major manufacturers of hospital sterilizers market units which permit in-chamber aeration after completion of the sterilization cycle. This isolates the load during aeration and eliminates the need to open the door and transfer the load after sterilization. This control option, however, effectively limits the number of loads which can be processed in a 24-hour period, since one sterilization cycle and one aeration cycle may occupy the unit for 15 to 18 hours.

#### EQUIPMENT MODIFICATION

Modification of the sterilizer cycle and the equipment may be used to control the EtO emissions. Reducing the chamber concentration by extending the EtO evacuation cycle(s) decreases the amount of EtO available for release into the operator's breathing zone when the door is opened at the end of the cycle. If unventilated, the antisiphon air gap in the discharge line of a water-sealed vacuum pump can emit large quantities of EtO. In addition, venting safety valves and chamber evacuation lines outside the building; installing, on large sterilizers, doors which can be opened from a remote locations; and providing interlocks so that the sterilizer doors can't be opened until the EtO concentration inside the chamber is safe should reduce EtO emissions/exposures.

## Chamber Evacuation/Flushing

Glaser called for sterilizer design to assure effective displacement of EtO following sterilization.<sup>4</sup> He commented that is it desirable to have repeated air flushing prior to opening the door. Nevenheim concluded that sterilizer design could be improved by extending the final exhaust cycle, thereby reducing the amount of EtO released when the door is opened.<sup>45</sup> Possible modifications include multiple vacuums (pulse-purge), repeating air flushes, and in-chamber aeration. The use of a door-cracked period also reduces the chamber concentration.

### Pulse Purge--

The cycles of some types of sterilizers can be modified to add a pulse-purge phase as the final vacuum. To begin this phase, a vacuum is drawn to about 10 inches Hg. A preset timer then controls the vacuum pump to provide 30 seconds of vacuum relief with incoming filtered air followed by 30 seconds of vacuum, through a differential vacuum of about 10 inches Hg. The sterilizer goes through approximately 30 pulse-purges in 30 minutes.

Samuels showed that adding a 15-minute "pulse-purge" period in the evacuation cycle reduced peak and short-term area EtO concentrations in front of the sterilizer immediately after door opening to less than half the levels measured when the standard vacuum cycle was used.<sup>46</sup> In other work, Samuels showed that a cycle purge on a table-top sterilizer was highly effective.<sup>47</sup> Peak exposures were reduced by a factor of 100 to 200. Short-term time-weighted average EtO concentrations were reduced by a factor of 20 to 50. In both studies, Samuels used a standard load consisting of 3.5 intermittent, positive pressure, breathing (IPPB) ventilator circuits per cubic foot of chamber capacity.

### Closed-door Air Flush--

Other sterilizers, both those which use the 12:88 gas mixtures and those which use pure EtO, can be modified to include a repeating air flush phase following either 1 or 2 vacuums. Following the final vacuum, the chamber begins to fill with filtered air to an absolute pressure of about 2 inches Hg. The filtered air continues to flush through the chamber for 20 minutes, at which point an end-of-cycle buzzer sounds. If the sterilizer door is not opened within about 90 seconds, the air flush repeats, and the door cannot be opened until the 20-minute phase is complete.

Barron *et al.* presented a graph showing that two vacuum cycles reduced EtO concentrations in the chamber from almost 200,000 ppm to approximately 6,000 ppm, and two additional 20-minute closed-door air flush periods further reduced the in-chamber EtO concentrations to approximately 500 ppm.<sup>48</sup> This study used a load consisting of AAMI test packs. Roy recommended modifying the sterilizer process controller to include a 30-minute closed-chamber "post-vacuum" air flush.<sup>49</sup> Barbi presented evidence that two 30-minute vacuum cycles or four 15-minute cycles were better than one 60-minute cycle. However, the fact that the four 15-minute cycles were slightly worse than the two 30-minute cycles suggests that the vacuum must be held for a certain minimum time to gain the full effect.<sup>50</sup>



#### In-Chamber Aeration--

Most sterilizer manufacturers offer models which feature in-chamber aeration. While the other cycle modifications discussed above reduce the chamber concentration at the end of the cycle, the operator still must transfer the load to an aerator. With in-chamber aeration, the load transfer is eliminated. Specific in-chamber aeration cycles differ with sterilizer models, but the principle is the same. Following the normal sterilization cycle, fresh, filtered air is drawn across the load and exhausted from the chamber for the same period of time the load would have stayed in an aerator. The disadvantage with such a system is that the sterilizer/aerator can only process one load in a 15-hour period.

#### Door-Cracked Period--

The door-cracked period is a chamber-concentration reduction procedure which can be used with any sterilizer, and it is recommended by most sterilizer manufacturers; however, local exhaust ventilation must be provided above the sterilizer door. By opening the door a few inches and allowing the door to remain open for 15 to 20 minutes, the warm air containing EtO rises out of the chamber along the top of the door. Cooler air from the room is drawn into the opening along the bottom of the door, thus creating a natural convection current. This process reduces the chamber concentration before the operator contacts the load for the transfer to an aerator.

#### Antisiphon Air Gap

Roy reported that using a vented liquid/gas separator (antisiphon air gap) reduced EtO concentrations from 120 to 30 ppm in the vicinity of the drain during the evacuation cycle. He went on to state that exhaust ventilation alone would have been sufficient.<sup>49</sup>

Corn reported that a liquid/gas separator added to the drain of a large sterilizer reduced measured concentrations in the drain area by a factor of 10.<sup>38</sup> AAMI has recommended some control for the drain, and mentions a vented liquid/gas separator or a local exhaust ventilation system near the drain as two effective methods.<sup>39</sup> AAMI also has stated that sponge absorbers should be prohibited because they are ineffective and potentially dangerous.

#### Power Door

Lathan and Glaser stated that the greatest potential occupational exposure to EtO occurs when the sterilizer door is opened at the completion of the sterilization cycle.<sup>51</sup> Doors which open automatically at the conclusion of the cycle would obviate the need for the operator to be in the vicinity of the door when it opens. However, this would increase the ambient concentration if ventilation was inadequate to control the escaping EtO. Some industrial sterilizers and a few hospital sterilizers are reported to have automated door opening.<sup>4,49</sup>

## Interlocks

Glaser reported some sterilizer doors could be opened (especially during a malfunction) during the sterilization cycle and/or the evacuation cycle.<sup>4</sup> Halleck stated in 1982 that sterilizers were fitted with door interlocks to prevent opening the door before excess EtO had been vented from the chamber and the pressure had reached an equilibrium with the ambient pressure, and that these interlocks have been redesigned to provide better control of door opening.<sup>43</sup> Churinetz et al. describe an interlock system on a storage room which did not allow the door to be opened until a high-flow ventilation system had reduced the concentration to an acceptable level.<sup>44</sup>

## Safety Valves

Roy recommended that check valves be installed in the gas lines near the tank to reduce the release of gas from the line during the cylinder changing operation.<sup>49</sup> He mentioned that a manual valve is an alternative, but it is less desirable because it requires a conscious effort to perform the extra step of closing it, whereas the check valve functions automatically. Check valves are not recommended unless a safety relief valve is used.

Halleck emphasized the importance of shutoff valves in the gas lines to prevent gas from escaping during cylinder changing operations.<sup>43</sup> Corn recommended the check valves for the gas line termination at the cylinder and suggested using a purge system when changing in-line filters.<sup>38</sup>

## Aeration

Aeration is normally accomplished at elevated temperature because this requires less time to reduce the concentration of residual EtO.<sup>39,49</sup> Ikeda has shown that the use of ultrasonic vibration during the aeration period further reduces the final concentration of residual EtO attained.<sup>52</sup>

Barbi reported that maximum offgassing of EtO is obtained when the sterilized load is kept at a pressure below the vapor pressure of the EtO/water solution for some time rather than returning immediately to atmospheric pressure, and that residual EtO concentrations decrease exponentially with aeration temperature.<sup>50</sup> This indicates that the aeration should be conducted at the highest temperature possible. He proposed a system for heated aeration at a sustained vacuum while maintaining approximately four chamber air changes per minute.

## LOCAL EXHAUST VENTILATION

Local exhaust ventilation (LEV) can be applied to all EtO emission sources. The goal is to capture and control the EtO before the gas can reach the operator's breathing zone or contaminate the workroom atmosphere. All LEV should be part of a dedicated system exhausted directly outside the building. The four EtO emission sources best controlled by LEV are the sterilizer door during the door-cracked period, the connection of the discharge line from a water-sealed vacuum pump to the floor drain, the connection of the EtO supply lines to the gas cylinders, and the overpressure relief valve on sterilizers which are

pressurized. Glaser<sup>4</sup>, AAMI<sup>39</sup>, and others<sup>38,40,43,47,49,51,53-57</sup> have specified the need for effective ventilation around sterilizer operations. The 1981 AAMI EtO ventilation guidelines have recommended contacting the manufacturer concerning the proper venting of sterilizers and aeration cabinets. They also recommended local exhaust ventilation but gave no details.<sup>39</sup>

Lathan and Glaser reported peak and short-term average concentrations in front of a number of sterilizers.<sup>51</sup> The concentration values varied considerably and did not seem to be related to sterilizer size or to the average number of cycles per day. They mentioned that the risk of EtO exposure for operators can be reduced by proper ventilation, but no ventilation information was given for the various sterilizers.

Korpella et al. reported peak concentrations of from 4 to 12 ppm EtO (varying somewhat with temperature and relative humidity of the cycle) for a 9-ft<sup>3</sup> sterilizer with the local exhaust fan shut off, while the concentration with the exhaust fan operating (at a capacity of 275 cubic feet of air per minute, cfm) was barely detectable.<sup>56</sup>

#### Sterilizer Door

Local exhaust ventilation may be applied along the top edge of the sterilizer door to capture the warm, EtO-laden air as it rises from the sterilizer chamber before the load transfer. The use of LEV in this location is particularly important when the door-cracked period is used at the end of the cycle. Any type LEV hood will have a defined capture control distance beyond which the LEV is not effective. This distance must be established for each application, and the sterilizer door must not be opened beyond that point during a door-cracked period.

AAMI has specified the area around the sterilizer door as the prime area for local exhaust ventilation (LEV).<sup>39</sup> A number of other references have recommended ventilation above the sterilizer.<sup>38,46,48,49,56</sup> Samuels presented data showing the benefits of installing LEV at the door of a table-top sterilizer.<sup>55</sup> A sidedraft hood with a baffle above the door was fabricated and set up for 150 ft/min airflow across the face of the open chamber. Peak EtO concentrations were reduced by a factor of 10 to 20, and short-term TWA concentrations of EtO were reduced by a factor of 2 to 40. Time-weighted average area concentrations of EtO, measured with a charcoal tube method, were reduced from 100 to 300 ppm to below detectable limits, and the 20-minute TWA operator exposure to EtO was reduced from over 5 ppm to less than 2 ppm.

Roy prescribed a canopy hood above the door with a design airflow of 100 cfm per square foot (cfm/ft<sup>2</sup>) of door area.<sup>49</sup> He stated that it should be mounted as close to the door opening as possible and include a side baffle along the door opening opposite the hinge. He mentioned that sidedraft or downdraft hoods may be necessary in some situations. Although he did not give design values for these configurations, he cited a particular example where, originally, 300 cfm were required for a downdraft hood to control a 10-inch diameter (0.55 ft<sup>2</sup>) door opening. When this hood was replaced with a

baffled sidedraft hood, 125 cfm/ft<sup>2</sup> proved to be effective. He stated these guidelines were found to be applicable for sterilizers ranging from table-top units to moderate size (70 ft<sup>3</sup>) freestanding or wall-mounted sterilizers.

Nusbaum has maintained that the ventilation should be placed below the door at floor level.<sup>54</sup> He presented a table which specifies 1,000 cfm for sterilizers with a volume of less than 150 ft<sup>3</sup>, up to 4,000 cfm for sterilizers greater than 1,000 ft<sup>3</sup> volume when downdraft ventilation is employed. He recommended doubling these flow rate values for ventilation above the door.

Markinson discussed the installation of a ventilation duct in the rear wall of a large industrial sterilizer. The duct was connected to a roof-mounted centrifugal fan with a capacity of 3,000 cfm. The fan was turned on by a microswitch when the door was opened.<sup>57</sup>

#### Drain

A sterilizer using the 12:88 gas mixtures is evacuated through a water-sealed vacuum pump. On the discharge side of the pump, water and EtO are released to a sewer drain. Because plumbing codes require an air gap between the sewer drain and any incoming line, all of the EtO from the chamber is released at the air gap. This air gap may be enclosed and local exhaust ventilation applied to capture the EtO. In situations where the vacuum discharge empties into an open floor drain, the floor drain may be enclosed with a capture box or exhaust hood.

AAMI<sup>39</sup> and others<sup>4,43,48,49,51,54</sup> have recommended ventilation for the drain area. Nusbaum has specified that ventilation be located 4 inches above an open floor drain pulling from 200 to 500 cfm for sterilizers ranging from less than 150 to greater than 1,000 cubic feet.<sup>54</sup>

#### Supply Cylinders

The 12:88 gas mixture is often supplied in 140-pound cylinders. The cylinders are connected to the sterilizer chamber with copper piping. Whether the cylinders are located in the mechanical access room or in the workroom, local exhaust ventilation can be supplied over the cylinder valves. The LEV may be either a hood or a flexible exhaust duct which can be moved over the valves during a cylinder change operation. A hood over the cylinders has the advantage of also controlling emissions resulting from a chance leaky connection.

AAMI<sup>39</sup> and others<sup>49,51,54</sup> have recommended ventilation of the area in which the gas cylinders are located and stored as a safety measure in case of leaks, and to control emissions during the cylinder changing operation.

Nusbaum recommended a separate 4-inch diameter duct for the EtO cylinder area, if the cylinders are not situated close to the floor drain ventilation or the sterilizer door ventilation.<sup>54</sup> He stated this branch duct should be sized to handle 300 cfm.

Roy suggested three possible alternatives.<sup>49</sup> The most effective one is to place the gas cylinders in a cabinet ventilated at a rate of 150 cfm per pair of cylinders. A second alternative is to use a slot hood above the cylinders, for which he recommended a ventilation rate of 100 cfm per cylinder. The third possibility is to install a flexible duct/flanged hood drawing 250 cfm which could be used for the cylinders and be available for maintenance operations and emergency situations.

#### Overpressure Relief Valve

Sterilizers which use the 12:88 gas mixture are pressurized to about 10 psig during the dwell period when the actual sterilization takes place. As an equipment safety feature, these sterilizers are fitted with an overpressure relief valve. If the chamber should become overpressurized, the valve would open and release EtO until the pressure returned to an acceptable level. The quantity of released EtO can be significant. Such an event can be controlled by installing a local exhaust hood over and around the valve.

AAMI has specified the area near the sterilizer chamber pressure relief valve as an area to consider when installing LEV.<sup>39</sup> Roy cautioned that the chamber emergency valve be connected to a vent line which should be hooked up to the existing exhaust ventilation.<sup>49</sup>

#### Inspection Table Ventilation

Nusbaum, in discussing controls for industrial facilities, recommended that the tables where test packages are removed and inspected should be ventilated.<sup>54</sup>

The ventilation systems may not continue to provide adequate control if it is not properly maintained, and, even if regular preventative maintenance is performed, some part of the ventilation system may malfunction. Nusbaum suggested that alarms be provided to alert personnel that the ventilation has failed.<sup>54</sup>

AAMI allowed for other means as well.<sup>39</sup> Two such methods would be visual indicators that the system is working or an interlock which would not allow the sterilizer to be operated without the ventilation fan being in operation. Just as with the sterilization equipment, any malfunctions should be repaired immediately.

#### Aerator Ventilation

Glaser<sup>4</sup> and others<sup>38,39,49,58</sup> have discussed ventilation of the aerators. Roy has given the guideline of 150 cfm for ventilation at room temperature in an aerator constructed from an office storage cabinet.<sup>49</sup> He specifies that ventilation to a dedicated exhaust is essential.

#### GENERAL VENTILATION

General ventilation standards for hospitals are set by each state's department of health. About 50 percent of the states have formally adopted one of three

standards: the Hill-Burton, the American Society of Heating, Refrigerating, and Air Conditioning Engineers (ASHRAE), or the National Fire Prevention Association (NFPA). Most adhere to the Hill-Burton standard, which was originally mandated in 1946 with the passage of the Hill-Burton Act which authorized federal funding for the construction of hospitals. The remaining states either have adopted their own standards or informally apply one of the aforementioned. However, any hospital whose construction is federally funded must comply with the Hill-Burton standard (unless the state applies a more stringent standard).<sup>59</sup>

Each of these standards specifies ventilation requirements for various sections of the many areas in the hospital. Table 1 is a comparison of two of the standards with respect to the sterilization department. The NFPA does not specify any requirements for ventilation in the central service area and is omitted from Table 1.

Glaser<sup>4</sup> and others<sup>39,40,47,53,54,55,58</sup> have stressed the importance of locating the sterilizer (and the aerator) in a well-ventilated area. Recent recommendations have concurred that, at a minimum, in each hour a ventilation volume equal to ten times the room volume should be removed from the room and replaced with unrecirculated air.<sup>4,38,39,54</sup> This minimal rate is referred to in the references as ten room air changes per hour. To apply this recommendation, a hospital would have to exceed the ventilation requirements of most state standards. Samuels reported that approximately 46 percent of 171 hospitals responding to a survey questionnaire stated that air change rates in their sterilization departments were fewer than ten per hour.<sup>60</sup>

Gunther et al. mentioned that the ambient concentration of EtO will be halved (theoretically, assuming perfect mixing) in the period of time required to exchange an amount of air equal to the volume of the room (6 minutes for the case of 10 room air changes per hour).<sup>61</sup> Samuels has reported that within 15 minutes, the ambient EtO concentrations when the air is changed 10 times per hour can be reduced to approximately one-half that concentration when the air is changed 20 times per hour.<sup>60</sup> The real-life situation may approach this theoretical performance if the general ventilation has been properly designed and adequate make-up air is provided.

Glaser<sup>4</sup> and Churinetz<sup>44</sup> have suggested that the storage room for sterile items should also be ventilated. No design values, other than the ten air changes per hour, are known for this specific application.

Churinetz described a high/low ventilation system for the sterile items quarantine area of an industrial facility. It features a normally low rate of ventilation (about four air changes per hour). If EtO sensors detect a rise in concentration above a preset limit, the high-flow ventilation, which delivers about 50 air changes per hour, is activated. Another feature is the red light/green light system. The room cannot be entered until an employee manually activates the high-flow system. When the concentration has been reduced to an acceptable level, the green light comes on indicating that the room is safe to be entered.<sup>44</sup>

Table 1. Ventilation standards.

|                        | Hill-Burton*            |                       |                | ASHRAE**                |                       |                |
|------------------------|-------------------------|-----------------------|----------------|-------------------------|-----------------------|----------------|
|                        | Outdoor Air Changes/Hr. | Total Air Changes/Hr. | Recir-culation | Outdoor Air Changes/Hr. | Total Air Changes/Hr. | Recir-culation |
| Sterilizer Equip. Rm.  | Optional                | 10                    | No             | Optional                | 10                    | No             |
| <u>Central Service</u> |                         |                       |                |                         |                       |                |
| Soiled Room            | 2                       | 6                     | No             | 2                       | 6                     | No             |
| Clean Work Room        | 2                       | 4                     | Optional       | 2                       | 4                     | Optional       |
| Unsterile Storage      | 2                       | 2                     | Optional       | Optional                | 2                     | Optional       |

\* Standard entitled "Minimum Requirements of Constructing and Equipment for Hospital and Medical Facilities," issued by the U.S. Government as the 1974 Hill-Burton Standard.

\*\* ASHRAE standard 62-73, "Standards for Natural and Mechanical Ventilation," published by the American Society of Heating, Refrigerating and Air Conditioning Engineers, Inc.<sup>59</sup>

## WORK PRACTICES

The work practices of the sterilizer operator can be very important in reducing personal exposure to EtO particularly during the load transfer. The goal of work practice controls is to minimize the transfer time from the sterilizer to the aerator and to maximize the distance between the operator and the sterile load.

Certain work practices can affect the emission of EtO into the workplace air and the exposure of workers to ambient EtO. Probably the most significant is opening the sterilizer door at the end of sterilization. Others involve how the load transfer is performed and other tasks which bring workers in contact with EtO emission sources. Informing workers about the hazards and ways to reduce exposure is essential.

Allowing the load to stay in an unventilated sterilization chamber with the door closed causes the chamber concentration of EtO to increase as the sterilized items offgas the residual EtO. AAMI, Samuels, and Corn have recommended transferring the load to the aerator within minutes after the completion of the post-cycle purges.<sup>38,39,46,47</sup>

Many references recommend opening the door slightly (a few inches), and leaving the area for 15 minutes before unloading the sterilizer. However, if this procedure is to be followed, there should be adequate local exhaust ventilation to eliminate the escaping EtO.<sup>2,4,37,43,50,51,53,54,56,61</sup>

There are numerous other procedures recommended by one or more references. Many of these references have stressed the importance of informing the employees about the health hazards of exposure to EtO, and instructing them on proper use and operating procedures (such as routinely cleaning the door gasket and pulling the cart containing the sterilized load instead of pushing it during transfer from the sterilizer to the aerator). This training should then be reinforced on a regular basis.<sup>1,2,4,37,41,44,48,50,59,62,63</sup>

## MAINTENANCE

With regard to exposure potential, maintenance is important in two different ways. First, if equipment (including the exposure controls) is not maintained, EtO may be emitted through leaky gaskets or not captured as expected by local exhaust ventilation. Second, workers performing maintenance on gas sterilizers or other equipment in the area may be exposed to EtO.

AAMI<sup>39</sup> and a number of others<sup>4,38,40,42,47,49,55,57,63</sup> have stressed the importance of a preventative maintenance program. Even if the equipment was properly designed and installed, inadequate maintenance can cause or allow the emission of EtO into the workroom air and may cause high exposures for maintenance personnel. The maintenance procedures, including preventative maintenance, and schedules may vary for each hospital, and are extremely important in reducing exposure of employees to airborne concentrations of EtO.

Leaks have most often been cited as a major source of potential high exposures. Regular checks of valve, tubing and piping connections, and door



gaskets should be conducted, so if a leak does occur, it can be fixed before it releases much EtO into the workplace.<sup>4,38,43,45,49,57,63</sup> Roy suggested using a "Freon® torch" leak tester used by refrigerator and air-conditioning repairmen to locate leaks for systems using EtO mixed with dichlorodifluoromethane.<sup>49</sup> However, the use of a "Freon® torch" leak tester would be a fire/explosion hazard if mistakenly used near a sterilizer which uses 100 percent EtO.

Maintenance workers should wear, or have available, the proper personal protective equipment to prevent skin and inhalation exposures. They should know the potential sources of EtO and what to do to avoid exposure while performing maintenance tasks.

#### MONITORING

Routine monitoring of the work environment is needed to ensure that the engineering control measures, and work and environment maintenance practices continue to perform effectively. Monitoring can be performed through conventional air sampling and by real-time environmental or equipment function sensors.

#### Air Sampling Methods

NIOSH recommends two sampling methods for EtO: Methods 1614<sup>65</sup> and 3702.<sup>66</sup> Method 1614 involves collection of EtO on HBr-coated charcoal tube (using a 100 mg front/50 mg backup charcoal tube), and measurement of a derivative of EtO (2-bromoethyl heptafluorobutyrate) by gas chromatography using an electron-capture detector. Method 1614 was issued in 1987, replacing Method 1607<sup>64</sup> which was utilized in this study. This method is a modification of OSHA Method 50.<sup>67</sup> The limit of detection of this method is 1 µg EtO per sample, corresponding to an 8-hour TWA exposure of approximately 0.02 ppm or a 10-minute exposure of about 0.4 ppm.

NIOSH Method 3702 describes a direct-reading technique utilizing a portable gas chromatograph with a photoionization detector. Samples are collected by drawing air directly into a syringe with subsequent injection or collection in a gas sampling bag. Use of a sampling bag can allow sampling times ranging from as low as a few seconds to an 8-hour TWA. The range of this method is 0.01 to 1,000 ppm.

Both NIOSH methods can be used to determine compliance with either the NIOSH recommended 8-hour time-weighted average (<0.1 ppm) or the OSHA limit of 1 ppm. Similarly, both NIOSH methods can be used to support either the NIOSH recommendation for a ceiling concentration of 5 ppm over a period of no more than 10 minutes or the OSHA excursion limit of 5 ppm over a period of no more than 15 minutes.

#### Air Sampling Strategies

NIOSH's Occupational Exposure Sampling Strategy Manual<sup>68</sup> suggests that the most reasonable sampling strategy, for the most efficient use of sampling resources, is to sample the employee presumed to have the highest exposure

risk. If there are a number of work operations as a result of different processes where there may be exposed employees, then a maximum risk employee should be selected for each operation. Samples taken for comparison with ceiling standards are best taken in a nonrandom fashion. That is, all available knowledge relating to the area, individual, and process being sampled should be utilized to obtain samples during periods of maximum concentrations of the substance.

In the preamble to their final rule on occupational exposure to ethylene oxide,<sup>35</sup> OSHA lists required monitoring activities for various exposure scenarios. These scenarios are described in Table 2. NIOSH<sup>69</sup> took a stronger position in comments to the Department of Labor opposing a recommendation to forego sampling under certain conditions: "The control of high concentrations of EtO over short periods of time depends on a number of actions, including good work practices and engineering controls. Initial and routine monitoring is needed to ensure that these work practices and engineering controls are still effective. The OSHA proposal assumes that if, at some point in time, exposures are below the PEL, then they will remain there."

#### Real-Time Monitoring Systems

Real-time monitoring devices are an integral part of a control system for EtO. These systems may be divided into two categories: (1) devices that directly monitor the sterilizer or its associated ventilation hardware; and (2) devices that indirectly monitor the performance of the control hardware by measuring the level of EtO present in the work environment.

#### Sterilizer and Ventilation Monitors--

This category includes rather unsophisticated sensors to directly monitor the sterilizer and indicate its operational status. An example of such a device is a mechanical sail switch. Sail switches determine the presence or absence of air flow in the exhaust ventilation ducts serving the sterilizer and the aerator. These sensors may be connected to a warning light or other alarm to alert the operator to this condition, or may be interconnected to the electrical control system of the sterilizer to prevent its operation without the presence of exhaust ventilation. Another example of this type of sensor are status alarms in areas remote from the sterilizer control panel such as mechanical access rooms, to indicate that the sterilizer is in an exhaust or purge cycle (when mechanical access room concentrations may be at their highest).

#### EtO Sensors--

The second category of monitoring devices are gas sensors which monitor worker exposure. These devices range from relatively simple and low-cost combustible gas sensors to relatively complex and expensive infrared spectrometers and gas chromatographs.

One combustible gas sensor observed in two hospitals consisted of a metal oxide sensor which increases in electrical resistance on contact with hydrocarbons. Output is nonlinear, but the device is factory calibrated as a dual set-point alarm, typically 20 and 50 ppm EtO. Since the device is not

Table 2. Sampling frequencies recommended by OSHA.

| Exposure Scenario  | Required Monitoring Activity   |
|--|--|
| Below the action level and at or below the EL.                             | No monitoring required.  |
| Below the action level and above the EL.                                   | No TWA monitoring required; monitor short-term exposures four times per year.                  |
| At or above the action level, at or below the TWA, and at or below the EL. | Monitor TWA exposures two times per year.  |
| At or above the action level, at or below the TWA, and above the EL.       | Monitor TWA exposures two times per year and monitor short-term exposures four times per year. |
| Above the TWA and at or below the EL.                                      | Monitor TWA exposures four times per year.   |
| Above the TWA and above the EL.  | Monitor TWA exposures four times per year; monitor short-term exposures four times per year.   |

Note: EL = excursion limit (5 ppm for 15 minutes)

specific for EtO (hydrocarbons, hydrogen, halogenated organics, carbon monoxide, and steam also produce responses), the threshold of detection must be set high enough to prevent a continuous state of alarm from the interfering compounds. The nonspecific nature of the sensor, the high threshold, and the nonlinear response of this type of device do not permit exposure to be estimated, but do allow for the detection of gross problems. The nonspecific character does provide an advantage in calibrating the observed device: the manufacturer provides calibration gas in the form of an ethane/air mixture which provides the equivalent response to 20 ppm EtO. Thus, a nontoxic gas mixture can be used in place of a potentially toxic mix. The manufacturer's maintenance and calibration procedures should be followed on receipt of the instrument for this type of device, followed by calibration checks at monthly intervals for the first 6 months to establish an instrument performance log. Thereafter, calibration checks should be performed at 6-month intervals.

More advanced gas detection systems utilize infrared spectrometers and gas chromatographs. Since these systems are specific for EtO (although several potential interferences exist for the infrared systems), they can be used to estimate exposure to EtO if the monitoring points are representative of worker exposures. Both systems are relatively costly (elaborate computer-based systems approaching the price of a sterilizer) and may require specialized training to maintain and operate. These systems are similar to the portable infrared and gas chromatograph systems utilized in this study and described in more detail in the next chapter. Neither infrared nor gas chromatograph systems were used in any of the hospitals visited during the field study. A gas chromatograph system was in use in the hospital where the hazard and operability study was performed (Appendix B).

Gas detection systems equipped with set-point alarms and relay contacts can serve as master control devices. In addition to activating alarms, these relay contacts can be used to start auxiliary ventilation systems and to energize emergency gas shut-off valves.

## THE EVALUATION OF CONTROL EFFECTIVENESS

### HOSPITAL SELECTION

In this study, hospitals were considered in the final site selection only if at least one load per day was run, but not so many loads as to preclude running a standardized "test load." The test load was run to eliminate, as much as possible, the effects on EtO emissions/exposures due to the variability of load composition from one hospital to another, and one day to the next. Usually, the test loads were run early in the day or during the evening shift. Every effort was made to not disrupt or change the normal routine any more than necessary to gather the information we needed.

Preliminary surveys were conducted in 14 hospitals to identify potentially good control systems. The hospitals selected for in-depth study were representative of several combinations of controls deemed to characterize the majority of sterilization operations, although it is recognized that the selected control systems do not account for every type of EtO sterilization process.

Evaluation of different control systems was conducted during in-depth field surveys in eight hospitals. Table 3 is a matrix of the control system characteristics for each hospital and/or sterilizer studied. The hospitals were arbitrarily given a letter designation to identify them in the following discussion. The evaluation strategy for the sterilization process and control system for each hospital was designed to characterize and document the efficacy of the control system by focusing on the determination of worker exposures and area concentrations; characterization of the ventilation system and associated controls; and analysis of work practices.

### AIR SAMPLING

NIOSH's Occupational Exposure Sampling Strategy Manual<sup>68</sup> suggests that the most reasonable sampling strategy, for the most efficient use of sampling resources, is to sample the employee presumed to have the highest exposure risk. If there are a number of work operations as a result of different processes where there may be exposed employees, then a maximum risk employee should be selected for each operation. Samples taken for comparison with ceiling standards are best taken in a nonrandom fashion. That is, all available knowledge relating to the area, individual, and process being sampled should be utilized to obtain samples during periods of maximum concentrations of the substance.

Personal EtO exposures and area EtO concentrations were determined using one or a combination of three methods: charcoal tube sampling, air bag sampling

Table 3. Control characteristics for sterilizers surveyed in this study.

| Hospital / Sterilizer | Type of Sterilizer | Extra Chamber Evacuation*       | In-Chamber Aeration | Local Exhaust Ventilation | Mechanical Access Rm./ Isolation | Discharge Control |
|-----------------------|--------------------|---------------------------------|---------------------|---------------------------|----------------------------------|-------------------|
| A / 1                 | 12:88              | In-Chamber Aeration             | Yes                 | Above Door                | Mech. Acc.                       | Vent. Air Gap     |
| B / 2                 | 12:88              | Air Flush + door-cracked period | No                  | Above Door                | Mech. Acc.                       | Vent. Air Gap     |
| C / 3**               | 12:88              | Air Flush + door-cracked period | No                  | Above Door                | Mech. Acc.                       | Vent. Air Gap     |
| D / 4                 | 12:88              | Pulse/Purge cycle               | No                  | Above Ster.               | Mech. Acc.                       | Vent. Air Gap     |
| E / 5                 | 12:88              | None                            | No                  | Above Ster.               | Mech. Acc.                       | Vent. Air Gap     |
| F / 7                 | 100%               | Air Flush + door-cracked period | No***               | Above Door                | Isolation                        | Venturi Vent.     |
| F / 8                 | 100%               | Air Flush + door-cracked period | No                  | Above Door                | Isolation                        | Venturi Vent.     |
| G / 9                 | 12:88              | Air Flush                       | No                  | Above Door                | Cabinet                          | Vent. Air Gap     |
| H / 10                | 12:88              | door-cracked period             | No                  | Above Ster.               | Isolation                        | Vent. Air Gap     |
| H / 11                | 12:88              | door-cracked period             | No                  | Above Ster.               | Isolation                        | Vent. Air Gap     |
| I / 6**               | 12:88              | door-cracked period             | No                  | Other                     | Mech. Acc.                       | No                |

\* In addition to one or two deep vacuums.

\*\* Same hospital - before (6) and after (3) installation of controls.

\*\*\* Although this sterilizer was fitted with in-chamber aeration, all loads sampled during the survey were transferred to an aerator.

with on-site analysis by gas chromatograph, and real-time monitoring. Table 4 summarizes the types of samples collected and the associated methods.

### Charcoal Tubes

To determine personal exposures and average concentrations of EtO at selected locations in the clean room, personal and area samples were collected using coconut shell charcoal tubes and analyzed according to NIOSH Method 1607.<sup>64</sup> The samples were collected on 400 mg and 200 mg charcoal tubes (SKC No. 226-37, SKC, Inc., Eighty Four, Pennsylvania) connected in series, and the sampling train was contained in a plastic holder. Personal sampling pumps (MDA Accuhaler® 808, MDA Scientific, Inc., Glenview, Illinois) with limiting orifices of approximately 10 milliliters of air per minute (mL/min) and 20 mL/min (one of each type orifice) were used to collect duplicate samples for the sterilizer operator and the area over the sterilizer door for long-term (8-hour) samples, and with limiting orifices of approximately 100 mL/min (samples in some hospitals used limiting orifices of approximately 50 mL/min) to collect duplicate samples for the same personal and area locations during the load transfer procedure (short-term, 15 to 20 minutes). MDA pumps with limiting orifices of approximately 20 mL/min were used to collect long-term samples for an instrument wrapper and the wrapping area location. Day and evening shifts were sampled for 3 days.

Personal long-term samples were used to estimate time-weighted average exposures for the sterilizer operator and an instrument wrapper. Area samples estimate the EtO which is in the workplace air near potential exposure sources. Given that the sterilizers and aerators are the primary sources for EtO release, long-term area samples were collected at a fixed location approximating the operator's breathing zone in front of each sterilizer. To estimate the effectiveness of the control system in preventing EtO contamination of the general workroom air, a long-term area sample was collected at a work table near the sampled instrument wrapper.

Short-term samples provided an estimate of the peak concentrations of EtO released when the sterilizer door was opened and the load was transferred to the aerator. Samples were collected both for the sterilizer operator and at the area sampling location in front of the sterilizer from the time the operator walked up to the sterilizer to crack the door at the end of the evacuation phase until the load transfer to the aerator was completed, and the operator left the sterilizer area.

### Gas Bags/Portable GC

Personal sampling pumps fitted with an outlet nozzle (DuPont P-4000, DuPont Company, Wilmington, Delaware) were used to collect air samples in Tedlar® gas sampling bags (SKC No. 231, SKC, Inc., Eighty Four, Pennsylvania). A short-term area sample over the sterilizer door was collected for 15 minutes during the load transfer procedure. A 2- to 3-minute sample was collected near the operator's breathing zone while the sterilizer operator transferred the sterile load to the aerator. To estimate the effectiveness of the evacuation phase and/or air flush phase in reducing the amount of EtO left in the chamber at the end of the cycle, a sample was collected in the sterilizer

**Table 4. Sampling strategy.**

| <b>Sample Location</b>                        | <b>Long-Term Samples</b> | <b>Short-Term* Samples</b>                      |
|---|--------------------------|---|
| Operator Exposure                             | Charcoal Tube            | Charcoal Tube, Gas Bag                          |
| Other Worker Exposure                         | Charcoal Tube            | -----   |
| Sterilizer Area                               | Charcoal Tube            | Charcoal Tube, Gas Bag, and Infrared Analyzer** |
| General Area                                  | Charcoal Tube            | -----   |
| Mechanical Access Room Area***                | Charcoal Tube            | -----   |
| Decontamination Area****                      | Charcoal Tube            | -----   |
| Chamber Interior (end of cycle)               | -----                    | Gas Bag   |
| Chamber Interior (end of door-cracked period) | -----                    | Gas Bag   |

\* Period of time including the load transfer, usually 1 to 2 minutes or 15 to 20 minutes depending on the particular hospital and type of sample and whether or not a door-cracked period was used.

\*\* The IR analyzer ran continuously, but its output was analyzed only during the (typically short-term) events which created elevated EtO concentrations

\*\*\* Partial-shift samples taken during three surveys.

\*\*\*\* Full-shift samples taken during one survey when it was suspected that EtO was escaping into the decontamination room from a poorly controlled mechanical access room.



chamber when the door was cracked open prior to the 15-minute waiting period or before the load was removed for those hospitals not using a 15-minute door-cracked period. Another sample was taken from the sterilizer chamber interior after the 15-minute waiting period, before the load was removed, to estimate the potential concentration of EtO to which the operator might be exposed. These latter two types of samples were collected for 15 seconds. All air bag samples were analyzed on-site with a portable gas chromatograph (Photovac 10a10, Photovac, Inc., Ontario, Canada) according to NIOSH Method No. 3702.66

### Infrared Analyzer

Due to the sporadic nature of EtO release during the day, it was desirable to have a continuous record of the estimated EtO concentrations in front of the sterilizer. An infrared (IR) analyzer (MIRAN® 1A, Foxboro Company, South Norwalk, Connecticut) was physically located either beside the sterilizer, or outside the sterilizer room for the two hospitals with isolated sterilizers, and connected by flexible, plastic tubing to a sampling probe located in the breathing zone area in front of the sterilizer. The IR analyzer continuously monitored the background EtO levels as well as indicated higher concentrations which could be associated with certain events such as transferring the load from the sterilizer to the aerator.

Peak concentrations may not be accurately measured with an infrared analyzer. The sensing cell of the instrument has a volume of about 5 liters and the sampling pump a flow rate of 5 L/min. This results in an instrument response time of approximately 3 to 5 minutes. Short concentration peaks (such as those associated with the load transfer) may be underestimated by the IR analyzer. Thus the IR analyzer responses were used qualitatively, and actual concentrations were interpreted as being greater than the measured peak values.

Laboratory experiments showed the instrument responded to a known concentration of EtO and humidity by indicating a higher concentration reading than the EtO level which was present. The sensitivity of the response at the 3.3  $\mu\text{m}$  wavelength was approximately 3 ppm EtO for a 10 percent rise in relative humidity. To compensate for this effect, the IR analyzer was connected in series with a hygromograph (General Eastern model 400C/D percent, General Eastern Corporation, Watertown, Massachusetts). The IR analyzer and the hygromograph were attached to a dual strip chart recorder to provide a continuous graphic record of changing humidity levels and EtO concentrations. This configuration allowed differentiation of the response of the IR analyzer to EtO from relative humidity.

The long-term samples were collected for a full shift. The short-term samples were collected for just long enough to span the event and obtain a representative sample, usually 1 to 2 minutes or 20 minutes depending on the particular hospital and whether or not the door-cracked period was used. The mechanical access room and decontamination area samples were not collected at every hospital. Even though the IR analyzer monitored continuously, its output was analyzed only during events which created elevated EtO concentrations, so it is considered a short-term sampler for this study.

## EVALUATION OF VENTILATION SYSTEMS

In evaluating the effectiveness of the sterilization department's overall control system, it was essential to adequately characterize the components of the ventilation system, both local exhaust ventilation and general dilution ventilation. Each component played a role in controlling the workers' EtO exposures.

### Local Exhaust Ventilation

Local exhaust ventilation is important in limiting the amount of EtO which leaves the airspace immediately in front of the sterilizer chamber opening, as well as other areas such as around the drain and the pressure relief valve and above the supply cylinders. The list of possible determinant variables applicable to the effectiveness of a local exhaust ventilation system includes:

1. Hood design, dimensions, and location with respect to the source(s) to be controlled.
2. Airflow patterns around the hood and source(s) to be controlled.
3. Hood flow rate.
4. Hood face velocity.
5. Capture velocity around source(s) to be controlled.

In evaluating the local ventilation system, several measurements and observations were necessary. First, the exhaust hood was characterized by its shape, dimensions, and location with respect to the exposure source (chamber door or drain). Second, airflow patterns around and between possible source points and the ventilation hood(s) were observed using smoke tubes (Dräger 4351, National Dräger, Pittsburgh, Pennsylvania). Third, measurements were made of the hood face velocity, selected airflow velocities between the source and the hood, and ambient airflow velocities around the source. Finally, the system design specifications were checked.

### General Ventilation

The proper use of general dilution ventilation can effectively reduce the ambient concentration resulting from EtO sources not controlled by other measures. Factors affecting the efficacy of general dilution ventilation as a control of employee exposure are the size and layout of the department, the location of supply air inlets and exhaust outlets, the airflow patterns within room, and the percent recirculation of air previously exhausted from the sterilizer area.

The determinant variables associated with an evaluation of general ventilation as a control are:

1. The volumetric flow rate and
2. The size of the room.
3. Airflow patterns in the room.

In assessing the general ventilation, a floor plan was drawn and the pertinent dimensions of the EtO sterilization area were measured, noting the location of

the air supply outlets and ventilation exhaust inlets. The volumetric flow rate for each supply or exhaust grille was measured using a velometer Flowhood® (Alnor Balometer®, Alnor Instrument Company, Niles, Illinois). If access to a particular grille was restricted, the volumetric flow rate was estimated by measuring the average velocity readings at each affected inlet or outlet and multiplying by the cross sectional area of the grille. These velocity measurements were taken using a hot-wire anemometer (TSI model 1650, TSI, Inc., St. Paul, Minnesota). The volumetric airflow rate through the local exhaust system was estimated by multiplying the average face velocity measurement and the cross sectional area of the hood.

The total volumetric flow rate exhausted from the room was computed by summing the individual local exhaust and general ventilation flow rates. This number was compared with the corresponding value for the total flow rate of air supplied to the room. In order to maintain a positive pressure with respect to areas outside the room so that air which may contain infectious agents does not enter the sterile supply room, there should be a slight (approximately 15 percent) excess of supply air. This excess also assures that the ventilation systems are working at peak capacity, not having to draw against a negative pressure. The pressure condition between the sterilizer room and the surrounding areas was checked using a smoke tube at the doorways to show if air was being pushed out of the clean room, indicating the desired positive pressure, or drawn into the room, indicating a net negative pressure.

Observations of the airflow patterns were made using standard smoke tubes. These tubes emit a thin trail of a chemical smoke when air is passed through them. The smoke follows the air currents; thus, it is possible to see both the direction and the speed of air movement. Visualizing and videotaping these patterns and the airflow between and around the various source points, workstations, ventilation openings, and other selected points in the room provided information on the potential exposure of employees with respect to their working in an airflow path between an exposure source and the exhaust.

Where possible, information on the system design, including duct sizing, fan ratings, and the provision for make-up air or recirculation, were obtained from engineering drawings or inspection. Finally, the system design specifications were checked.

#### **EVALUATION OF WORK PRACTICES**

Observations of the employees' work practices were an important part of characterizing the personal exposures. For a given situation with a certain potential exposure and a particular combination of control measures, the actual employee exposure varied considerably depending on how the worker performed the job.

Each load transfer was videotaped and analyzed to characterize the effect of the work practices on exposure. The following variables were determined:

1. Job tasks of each worker to be sampled.
2. Identification of high exposure tasks.
3. Workstation for each high exposure task.

4. Door opening procedure at the end of the cycle.
5. Method of inserting and removing items - basket and/or cart.
6. Time for transferring items from sterilizer to aerator.
7. Handling of transfer cart or basket - pull, push, or swing to aerator.
8. Amount of time in close contact with newly sterilized items.

Potentially high exposure tasks were identified. Certain tasks, such as opening the sterilizer door and handling the sterilized items, and other potentially high exposure situations were analyzed to determine if the manner with which each was performed contributed to an increased potential for exposure to or the emission of EtO. The use of personal protective equipment was noted. This analysis was included in the interpretation of the sampling results obtained from each survey.

#### **ANALYSIS OF DATA**

The data were eventually stored in computer files. Various statistical procedures were used to characterize and compare the data. The statistical analyses were applied using the appropriate SAS/STAT<sup>®</sup> Procedures for personal computers, Version 6 Edition (SAS Institute Inc., Cary, North Carolina).

## RESULTS

Personal exposures and area concentrations, ventilation measurements, and work practice observations for the study are reported below. The hospitals are identified by an arbitrary letter designation (see Table 3). Two of the hospitals had two sterilizers, and in some cases it was necessary for the sterilizers to have a unique identifier, so they have been arbitrarily numbered from 1 to 11. (Note: the letter and number designations are not related to expected effectiveness or any other specific factor.)

### AIR SAMPLING

Two of the three types of air samples consisted of at least two different groups of samples. The charcoal tube samples were taken for a full shift and/or a short-term period. For the gas bags, some of the samples were taken for every load, and others were taken only occasionally. Certain values were computed from the infrared analyzer data to be compared with the other methods.

Comparing the time-weighted average results of short-term samples with different sampling periods can be misleading when the concentration is elevated for only a fraction of the sampling period. For example, referring to Figure 4, the time-weighted average for the 2-minute sampling period is much greater than for the 15-minute sampling period, even though the worker was exposed to the same quantity of EtO. This distortion can be rectified by working with the "exposure-dose" or concentration-time product (ppm-min). Mathematically, this is the area under the curve (i.e., the integral) of the instantaneous concentration; the quantity which is divided by the sampling time to yield the time-weighted average. The value of this measure is that when the bulk of an exposure may have occurred in a short period of time, as is shown in Figure 4, the same concentration time product would result as long as the exposure peak occurred within the sampling period. Therefore, in the situation illustrated in Figure 4, the time-weighted average concentration would differ greatly; but the computed exposure-dose would be the same.

Generally, all the data are lognormally distributed. Therefore, the logarithms of the values were used in all statistical analyses. However, the results have been transformed back to the original units (ppm or ppm-min) for presentation in the report.

Although in some cases the results seemed different depending on whether test loads or normal loads were processed, no formal statistical test showed a significant difference between test loads and normal loads. The SAS® t-test procedure (PROC T-TEST) was used on all the data separated by hospital, sterilizer, sampling site, day, and shift. None of the individual t-tests resulted in a probability of a greater absolute value of t under the null hypothesis (i.e., the 2-tailed significance probability) of less than 0.01.

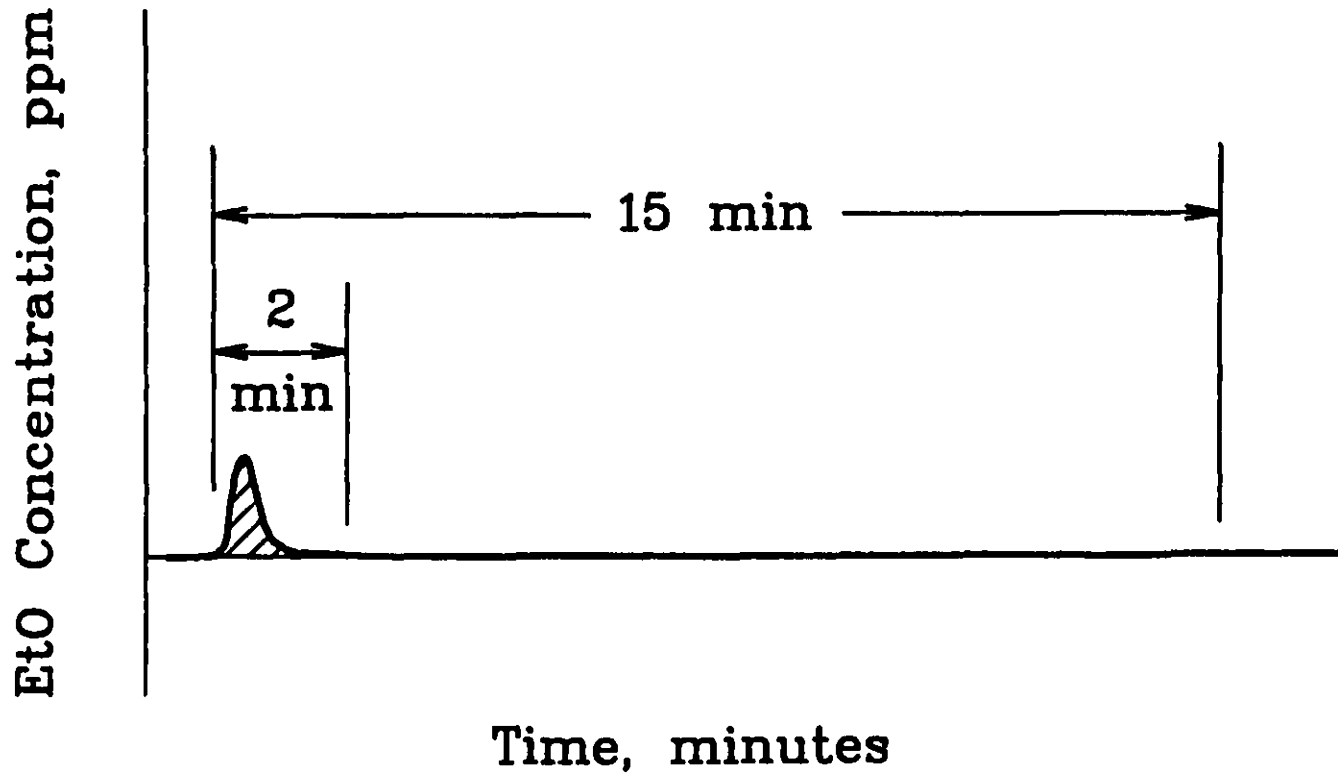

Figure 4. Two different sampling periods, each containing the same exposure peak, have different average concentrations but the same concentration-time product represented by the cross-hatched area.

Most of the values for Prob>|T| were greater than 0.1. Thus, all loads are considered together in the following comparisons unless otherwise noted.

#### Charcoal Tubes

For Hospital A, almost all the charcoal-tube sample results were indistinguishable from the results reported for the field blanks. These results are interpreted to represent no detectable EtO on the samples. In fact, almost all the charcoal tube results were near the limit of detection (LOD) of the analytical method. Table 5 lists the various LODs for the different surveys and the percentage of samples less than each LOD at each hospital.

Because of the number of samples below the limit of detection, complete data were not available for many of the hospitals. For some of the surveys, most of the results were reported as being less than a LOD which was higher than other "detected" samples at that hospital. Such values cannot provide meaningful results in parametric analyses. Thus, it was decided to use only values greater than the LOD because using an estimated value (e.g., 1/2 concentration corresponding to the LOD) based on the LOD for an unknown ("not detected") result could be misleading. This approach reduces the number of data points used in the analyses; in some cases, resulting in no data points at all for a hospital.

#### Full-Shift Results--

All full-shift time-weighted averages were less than 1 ppm. Most were less than 0.1 ppm; however, for Hospital I -- the hospital with the fewest controls -- all the full-shift results were greater than 0.1 ppm. The values are listed in Table A-1.

Figures 5 to 8 show the distribution of values for the detected full-shift charcoal tube samples. Separate figures are presented for the sterilizer operator, the other worker for which a personal sample was collected, the area in front of the sterilizer, and the other area sampled. In Figure 5, only Sterilizer 6 (Hospital I) routinely had values greater than the NIOSH Recommended Standard. The one detected sample for Sterilizer 3 was collected when the drain was not properly sealed, and it is not representative of the other values which were less than the analytical detection limits. Referring to Figure 6, Sterilizers 7 and 8 (Hospital F) and Sterilizers 10 and 11 (Hospital H) were located in sterilizer isolation rooms.

#### Short-Term Results--

Except for four samples in Hospital 1, all the values for the operator exposure-dose were less than 20 ppm-min. A number of values for the short-term area concentration-time product in front of Sterilizers 6, 10, and 11 were greater than 50 ppm-min, the product of the 5 ppm ceiling limit and the maximum time period for exposures this high of 10 minutes recommended by NIOSH. This indicates the potential for overexposure if workers spent too much time on this area during this period of elevated concentration. Figures 9 and 10 show the distribution of values. Table A-2 lists all the short-term charcoal tube results.

Table 5. Charcoal tube samples below the limit of detection

| Hospital | LOD<br>µg | number of<br>samples | percent of samples<br>below LOD |
|----------|-----------|----------------------|---------------------------------|
| A        | 0.36*     | 35                   | 94                              |
| B        | 0.1       | 66                   | 52                              |
| C        | 0.2       | 20                   | 85                              |
|          | 0.4       | 24                   | 54                              |
|          | 0.9       | 26                   | 69                              |
|          | 1.4       | 73                   | 89                              |
| D        | 0.29      | 22                   | 68                              |
|          | 0.33      | 19                   | 53                              |
|          | 0.5       | 19                   | 47                              |
|          | 1.2       | 1                    | 0                               |
| F        | 0.1       | 96                   | 6                               |
| G        | 0.1       | 78                   | 3                               |
| H        | 0.2       | 21                   | 5                               |
|          | 0.4       | 19                   | 11                              |
| I        | 0.1       | 73                   | 0                               |

\* based on field blanks



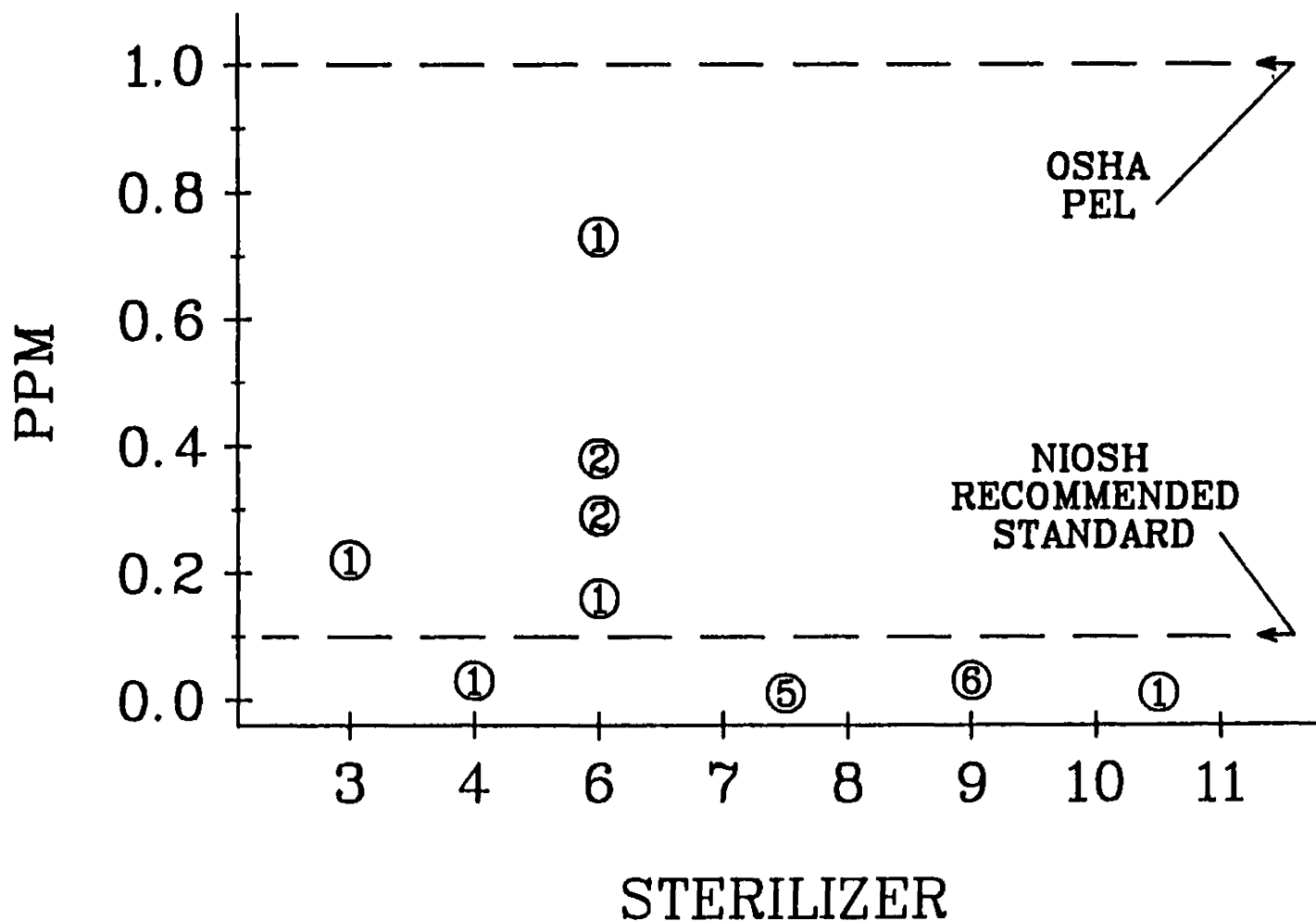

Figure 5. The number of samples with concentrations in the ppm range covered by the circle for the full-shift exposures for sterilizer operators, sampled with charcoal tubes, is shown for each hospital represented by sterilizer number. Note that Sterilizers 7 and 8 were in one hospital; Sterilizers 10 and 11 were in another hospital.

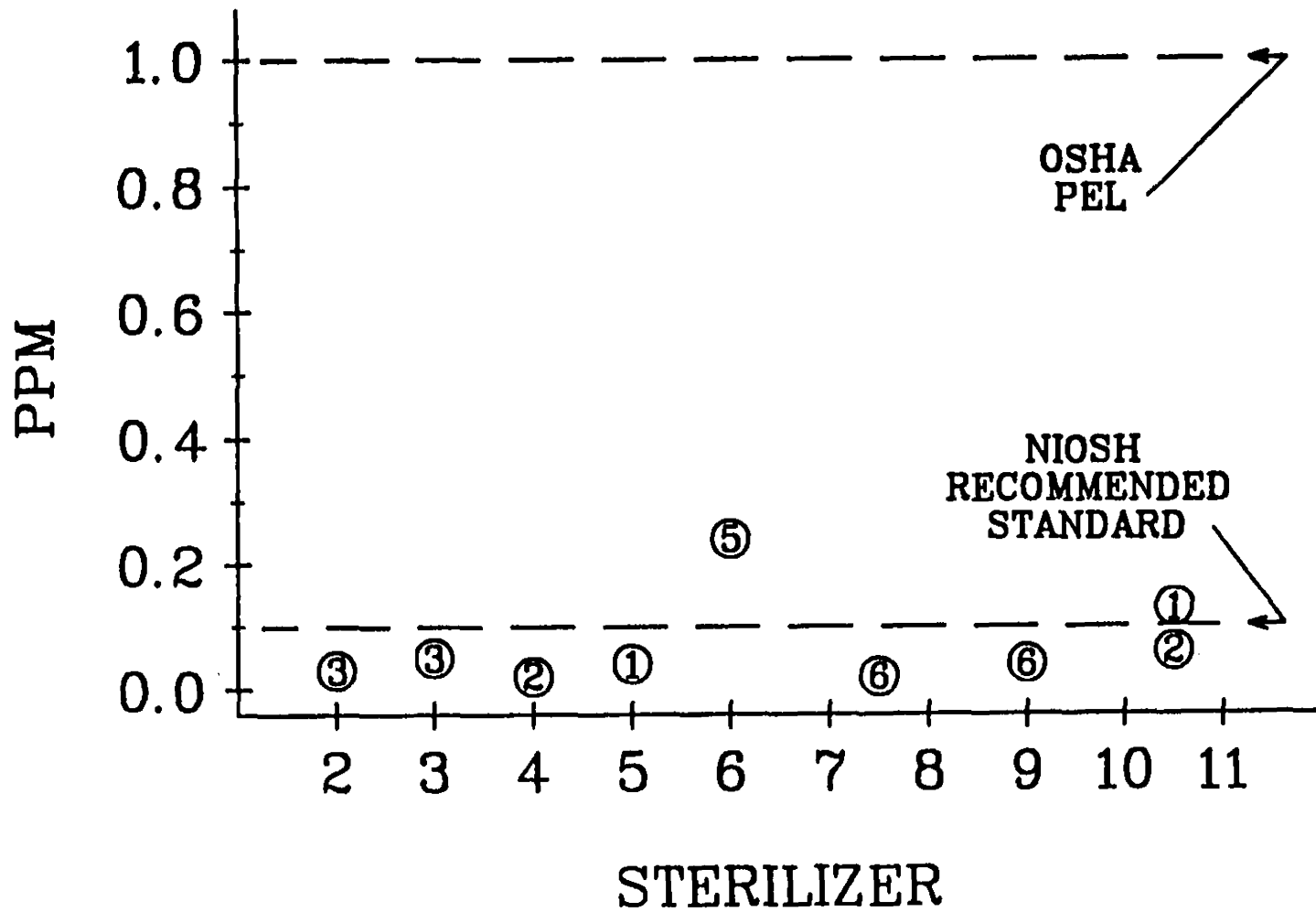

Figure 6. The number of samples with concentrations in the ppm range covered by the circle for the full-shift area concentrations in front of the sterilizers, sampled with charcoal tubes is shown for each sterilizer.

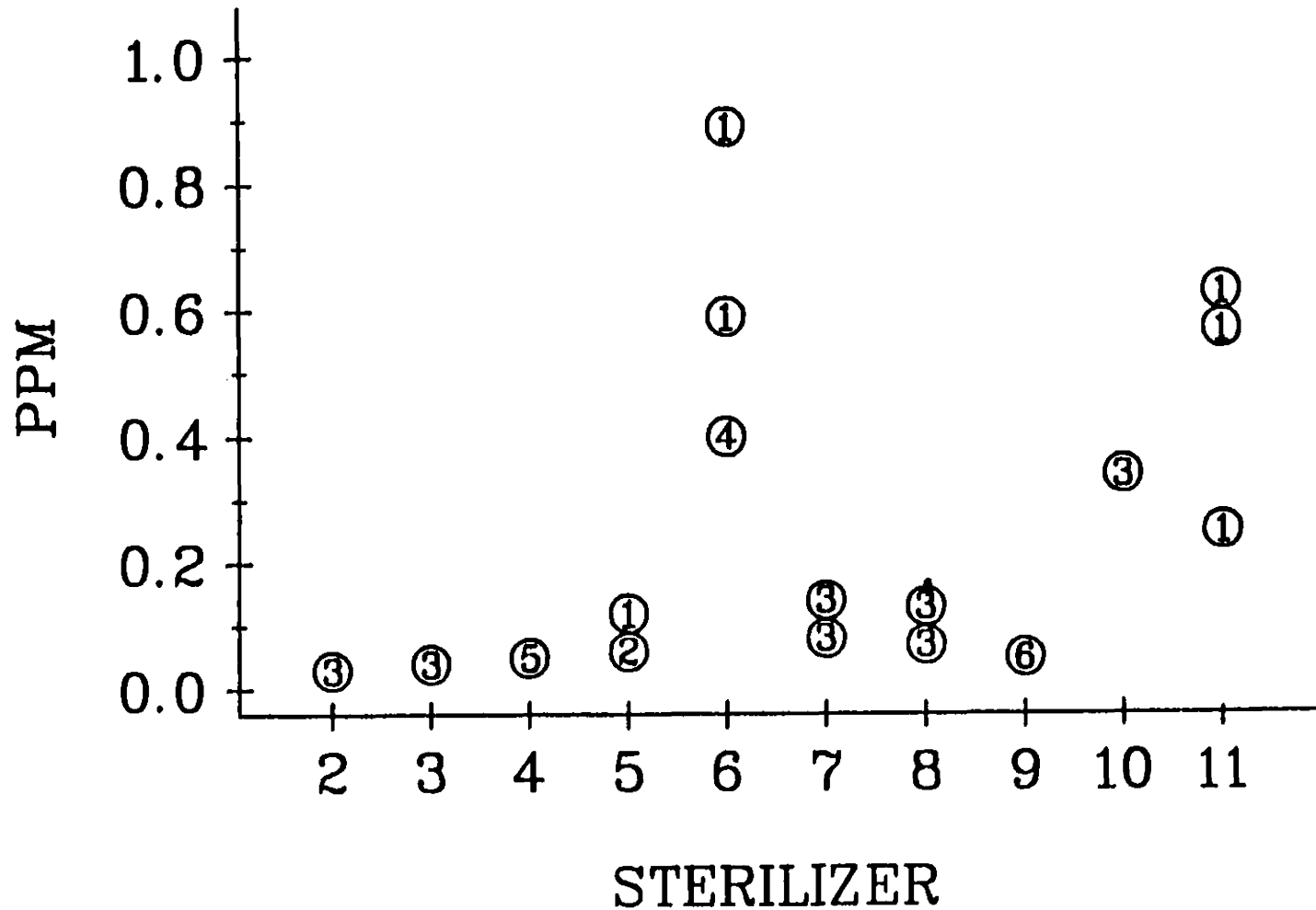

Figure 7. The number of samples with concentrations in the ppm range covered by the circle for the full-shift exposures of the other workers sampled with charcoal tubes is shown for each hospital represented by sterilizer number. Note that Sterilizers 7 and 8 were in one hospital; Sterilizers 10 and 11 were in another hospital.

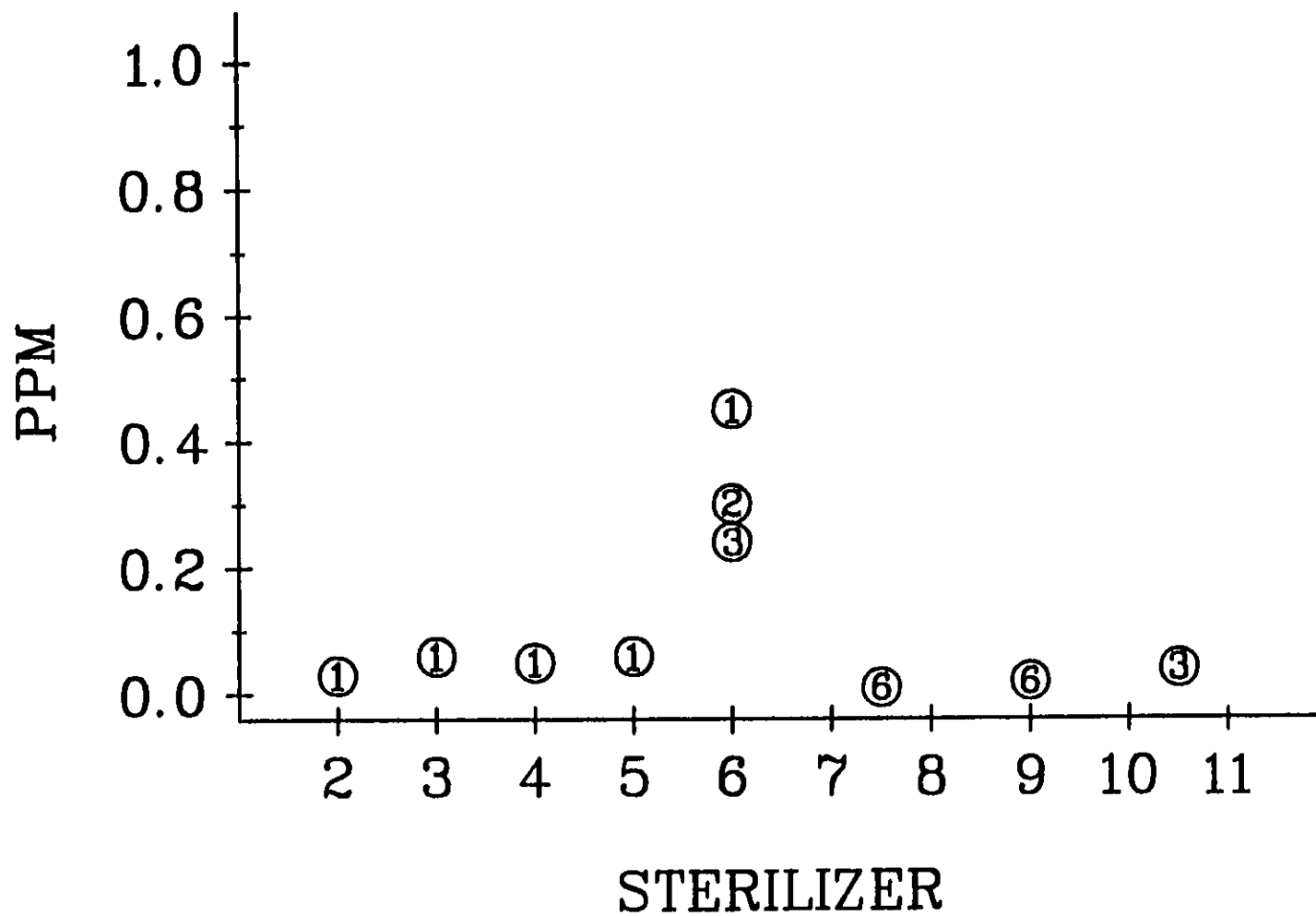

Figure 8. The number of samples with concentrations in the ppm range covered by the circle for the full-shift concentrations at the other area location sampled with charcoal tubes is shown in each hospital represented by sterilizer number. Note that Sterilizers 7 and 8 were in one hospital; Sterilizers 10 and 11 were in another hospital.

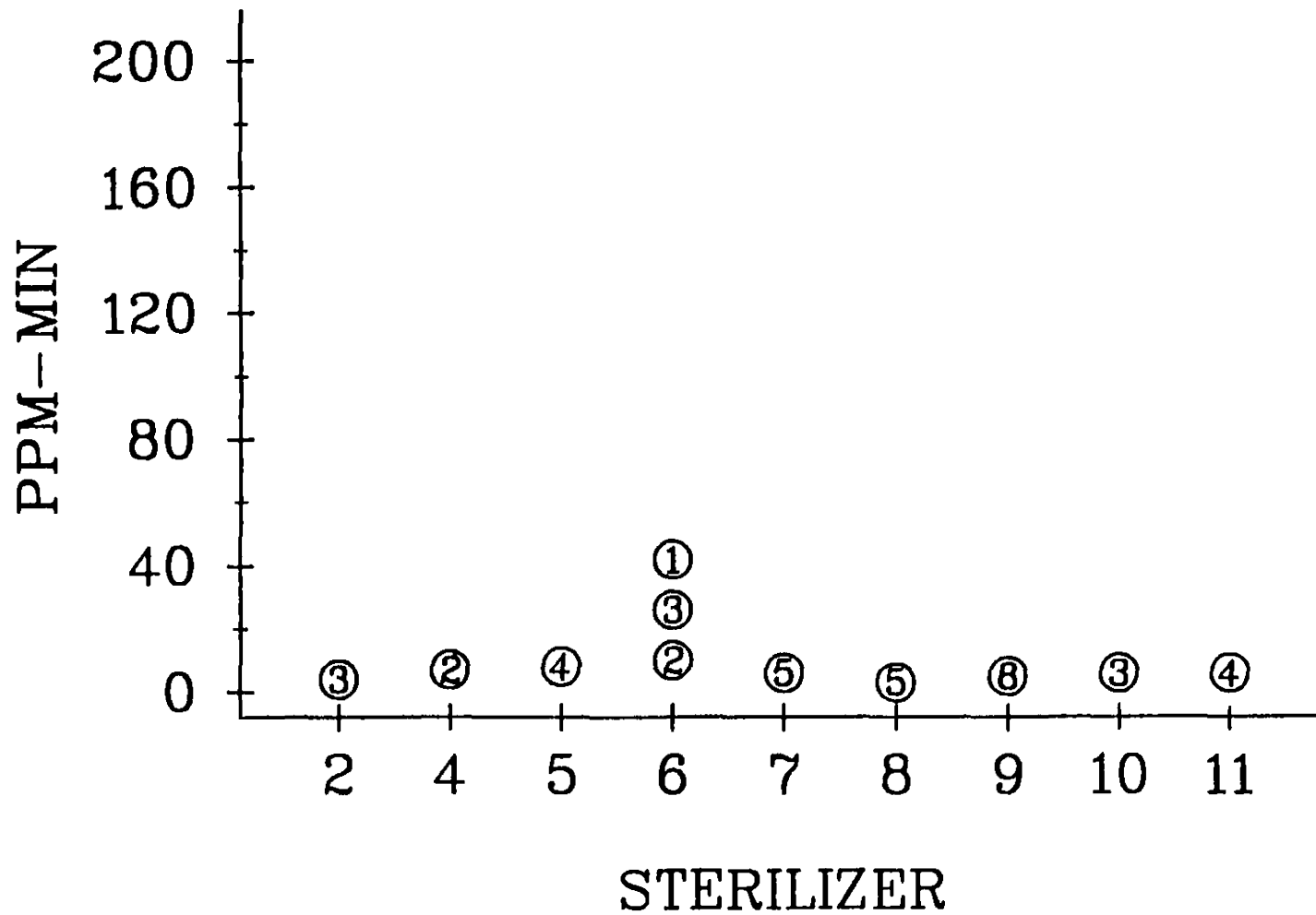

Figure 9. The number of samples with concentrations in the ppm-min range covered by the circle for the short-term exposures for sterilizer operators, sampled with charcoal tubes, is shown for each sterilizer.

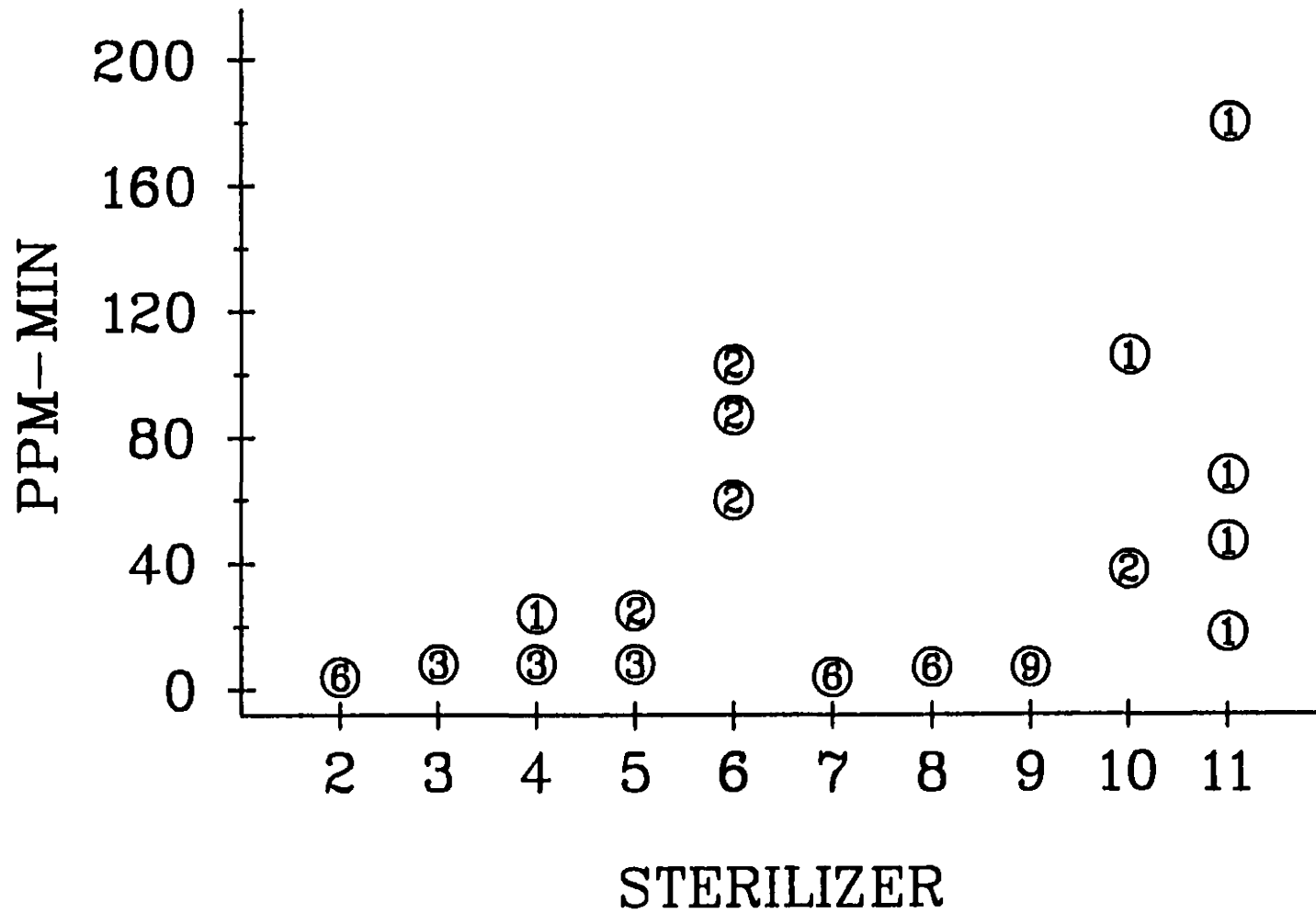

Figure 10. The number of samples with concentrations in the ppm-min range covered by the circle for the short-term area concentrations in front of the sterilizers, sampled with charcoal tubes, is shown for each sterilizer.

## Gas Bags/Portable Gas Chromatograph

Other than the samples in Hospital A, only a few of the samples collected on gas bags were less than the LOD of the portable GC. Figures 11 and 12 show the distribution of values for the short-term gas bag samples for the sterilizer operators and the area in front of the sterilizers. All the operators' exposure doses were less than 20 ppm-min. Four sterilizers (4, 6, 10, and 11) had concentration-time products for the area in front of the sterilizers greater than 50 ppm-min. These results are similar, although not in complete agreement with the similar samples collected with charcoal tubes. All the gas bag/portable GC results are reported in Tables A-3 and A-4.

Figure 13 shows the distribution of values of chamber concentration collected just before the door was fully opened to remove the load. Except for Sterilizers 4, 5, and 9, for which a door-cracked period was not used, almost all the individual values are less than 300 ppm. For Sterilizers 1, 7, and 8, all values were less than 20 ppm -- Sterilizer 1 used in-chamber aeration; Sterilizers 7 and 8 used single-dose cartridges. All the results for the concentration in the sterilizer before the door was partially opened to start a door-cracked period (dc-ppm) and/or just before the door was fully opened to remove the load (do-ppm) are listed in Table A-5.

Table 6 lists the results of bag samples collected on a nonroutine basis. These samples were collected as the opportunity arose. Although these data are limited by the lack of replications, some of the individual samples seem especially interesting in their relationship to other observations. Personal and area samples for a cylinder change operation averaged 0.1 ppm at Hospital A, which had local exhaust ventilation above the supply cylinders. The EtO supply line connection to the cylinders at Hospital B had neither local exhaust ventilation nor a vent valve, and when the supply line was disconnected to change the cylinder, EtO sprayed out resulting in both a skin exposure and an area concentration of approximately 100 ppm.

At Hospital C, the short-term exposure to the operator while arranging the items in the aerator was 0.3 ppm and the corresponding concentration in the aerator before the door was fully opened was 1.8 ppm. Similarly, at Hospital I, the exposure to the operator while arranging items in the aerator was 0.5 ppm, and the concentration in the aerator before the door was fully opened averaged 1 ppm. A higher concentration (2.1 ppm) was measured in the aerator of Hospital G, but generally, the aerator did not seem to be a significant exposure source.

The sterilizer chamber retains EtO if not "aired-out." For Hospital G, the load was transferred without a door-cracked period and then the sterilizer door was closed. The concentration inside the chamber some time (a few hours) after the load transfer averaged over 200 ppm. At Hospital D, although a door-cracked period was not used prior to load transfer, the door was left partially open overnight. The chamber concentration prior to cleaning the interior of the sterilizer chamber the next morning averaged 0.56 ppm, and the exposure to the worker while cleaning the sterilizer chamber averaged 0.27 ppm.

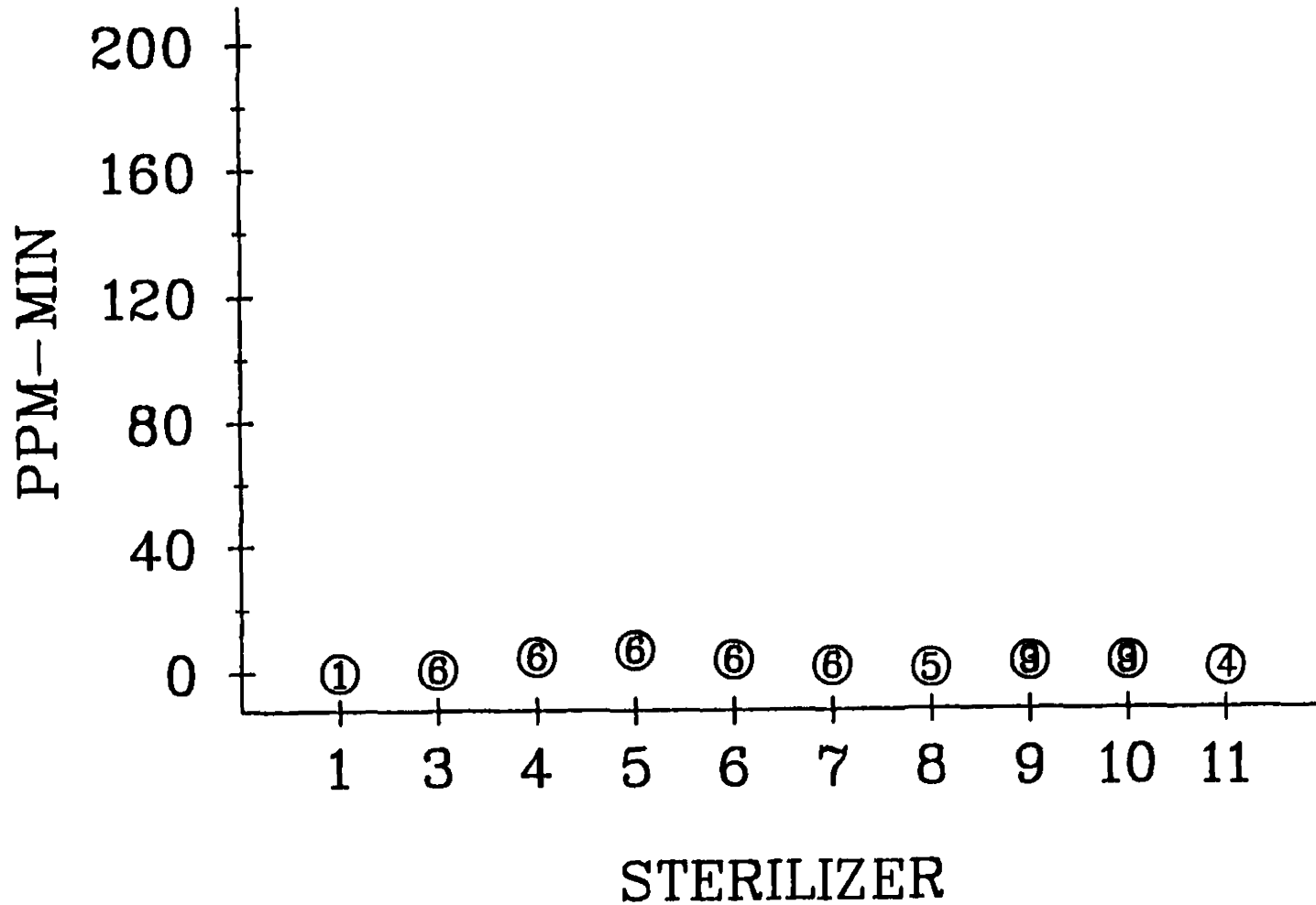

Figure 11. The number of samples with concentrations in the ppm-min range covered by the circle for the short-term exposures of the sterilizer operators during just the load transfer, determined by portable gas chromatograph analysis of gas bag samples, is shown for each sterilizer.



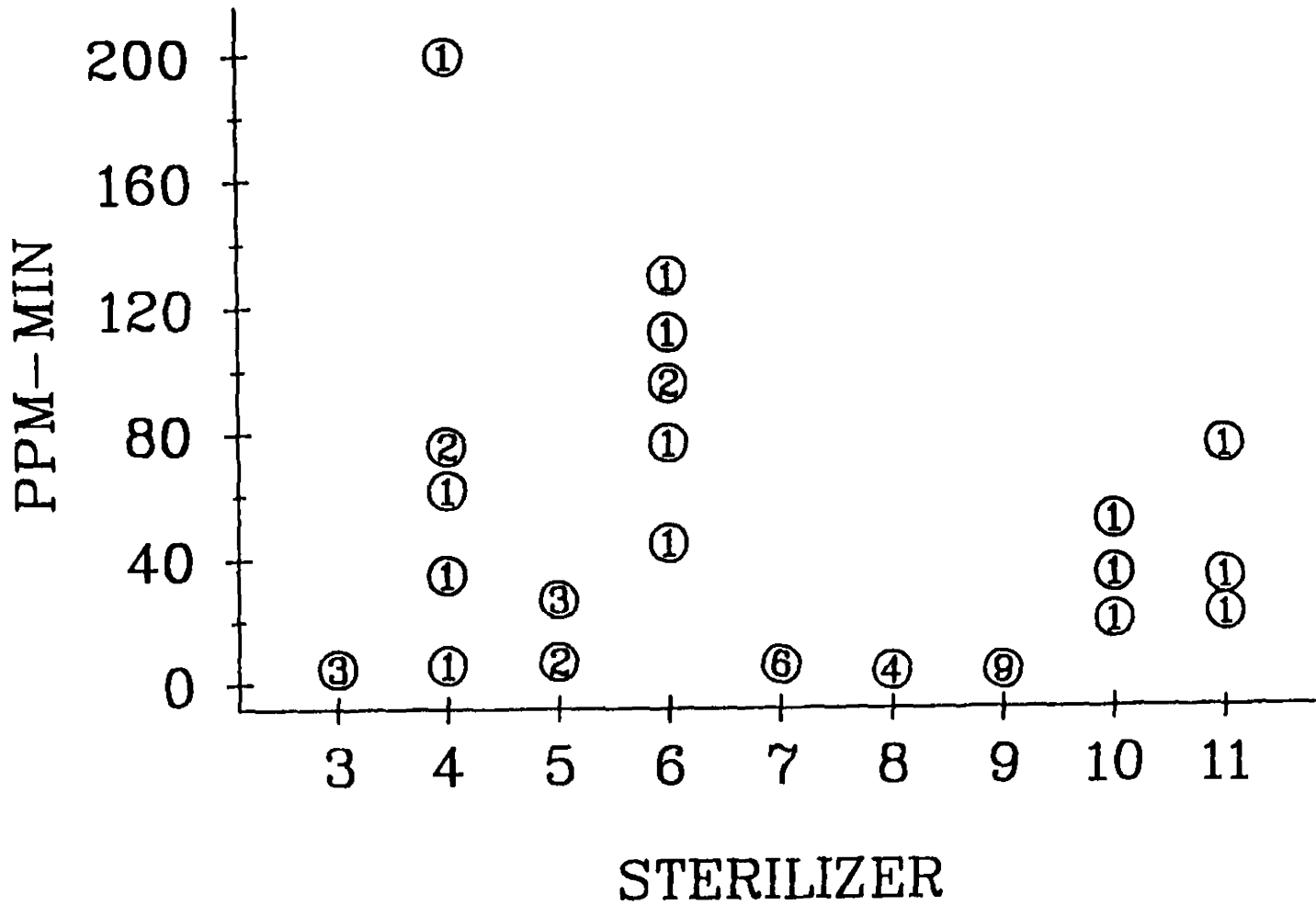

Figure 12. The number of samples with concentrations in the ppm-min range covered by the circle for the short-term area concentrations in front of the sterilizers determined by portable gas chromatograph analysis of gas bag samples is shown for each sterilizer.

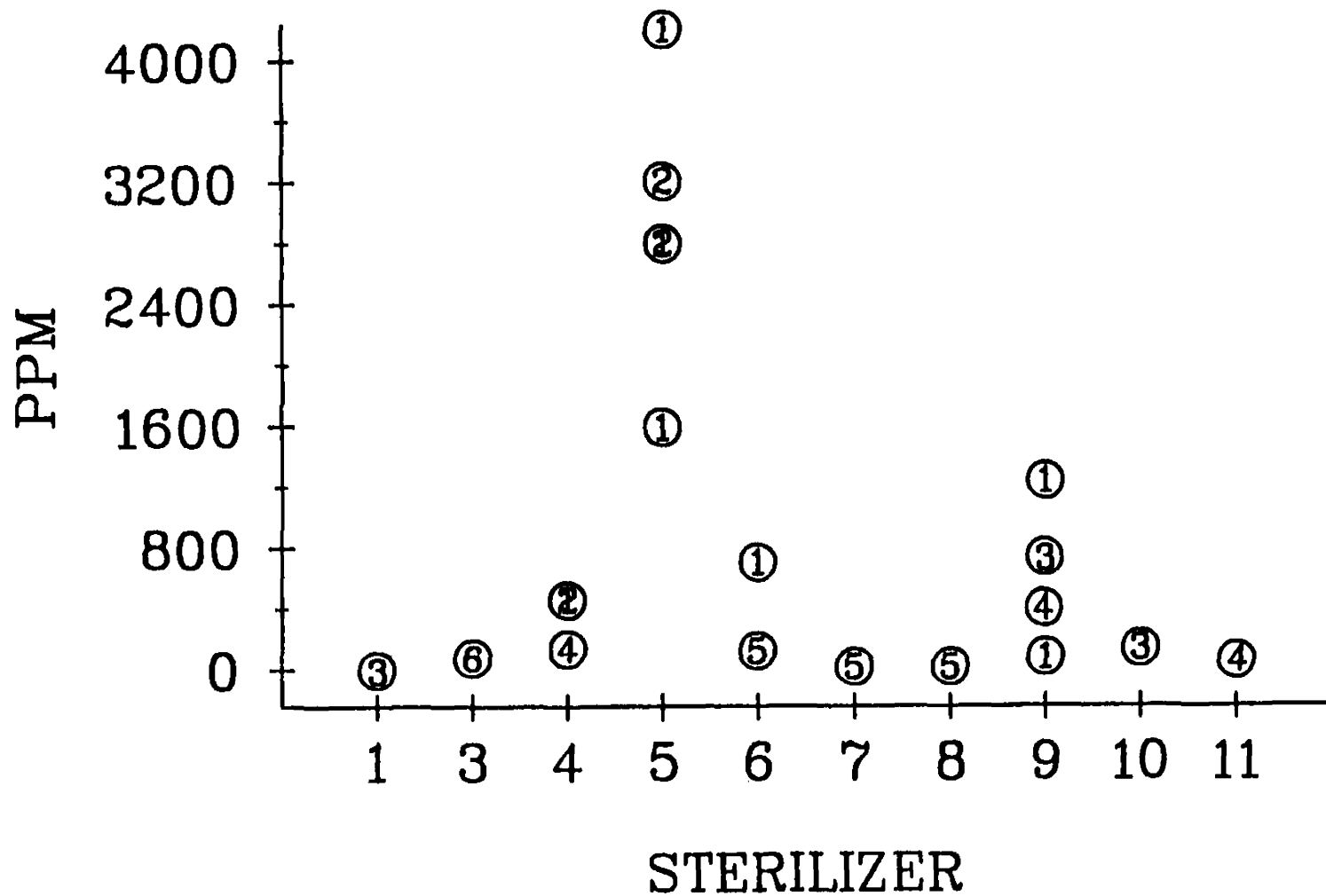

Figure 13. The number of samples with concentrations in the ppm range covered by the circle for the concentration in the sterilizer when the door was opened to remove the load, determined by portable gas chromatograph analysis of gas bag samples, is shown for each sterilizer.

Table 6. Results\* of selected nonroutine gas bag samples.

| Hospital | Description of Sample                            | ppm (#)** |
|----------|--|-----------|
| A        | Personal sample during cylinder change operation | 0.1 (1)   |
|          | Area sample during cylinder change operation     | 0.1 (1)   |
| B        | Area sample during cylinder change operation     | 100. (1)  |
| C        | Operator arranging loads in aerator              | 0.3 (1)   |
|          | Inside aerator chamber                           | 1.8 (1)   |
|          | Above load after sterilization                   | 57. (2)   |
|          | Operator opening biological indicator pack       | 0.2 (1)   |
| D        | Operator cleaning sterilizer chamber             | 0.27 (3)  |
|          | Inside Sterilizer Chamber                        | 0.56 (3)  |
| G        | Inside aerator chamber                           | 2.1 (1)   |
|          | Inside Sterilizer Chamber                        | 214. (2)  |
| H        | Worker performing maintenance                    | 3.5 (1)   |
| I        | Operator arranging loads in aerator              | 0.5 (1)   |
|          | Inside aerator chamber                           | 1.0 (2)   |
|          | In front of sterilizer during maintenance        | 13. (2)   |
|          | In front of sterilizer, not during purge or LT   | 0.30 (3)  |

\* Geometric mean if more than one sample

\*\* The number of samples is in parentheses

The newly sterilized load can be a source of EtO. The concentrations measured during the load transfer at Hospital C ranged from 7 ppm approximately 10 inches above the load to 106 ppm approximately 2 inches above the load. However, the exposure to the operator while opening the biological indicator pack was 0.2 ppm.

Sterilizer maintenance can also lead to EtO exposure. The exposure to a worker performing maintenance on the water-sealed vacuum pump of a sterilizer in Hospital H averaged 3.5 ppm for approximately 1 minute. At Hospital I, during maintenance on the EtO supply system in the mechanical access room, the concentration in front of the sterilizer averaged 13 ppm, and 0.3 ppm during a time when elevated concentrations were not expected.

### Infrared Analyzer

Typical responses of the infrared (IR) analyzer with the probe placed at the area location in front of the sterilizer during the purge cycle and the load transfer are shown in Figure 14. This information is not available for Hospital H -- at this hospital the IR analyzer monitored the appearance of EtO in front of one sterilizer during the purge cycle and load transfer for the other sterilizer.

Although instantaneous values measured by the IR analyzer were not considered accurate due to drift and a slow response, computing the area under the curve averages out these deficiencies. The average ppm-min and ppm values thus obtained are reported in Table 7. All the values gleaned from the IR tracings are reported in Appendix A, Table A-6.

## VENTILATION

### Local Exhaust Ventilation

All but one of the hospitals (Hospital I) had local exhaust ventilation (LEV) above the door of the sterilizer. Some pertinent data about the LEV hoods is summarized in Table 8. In most cases, the velocity (ft/min) of the air flowing into the hoods was measured at the face of the opening. If not, this value has been calculated by dividing the volume flow rate by the area of the opening at the face of the hood. Some hoods were located above the control panel rather than immediately above the door. These were usually larger, extending out further from the front panel of the sterilizer. These values along with the volume flow rate (ft<sup>3</sup>/min) are presented in the table.

### General Ventilation

The volume flow rate for the room in which most of the sterilization operations were located varied considerably. Even when adjusted for the volume of the room (often referred to as room air changes per hour), the values are still highly variable. These values for both the clean room, mechanical access room, and/or isolation room are reported in Table 9.

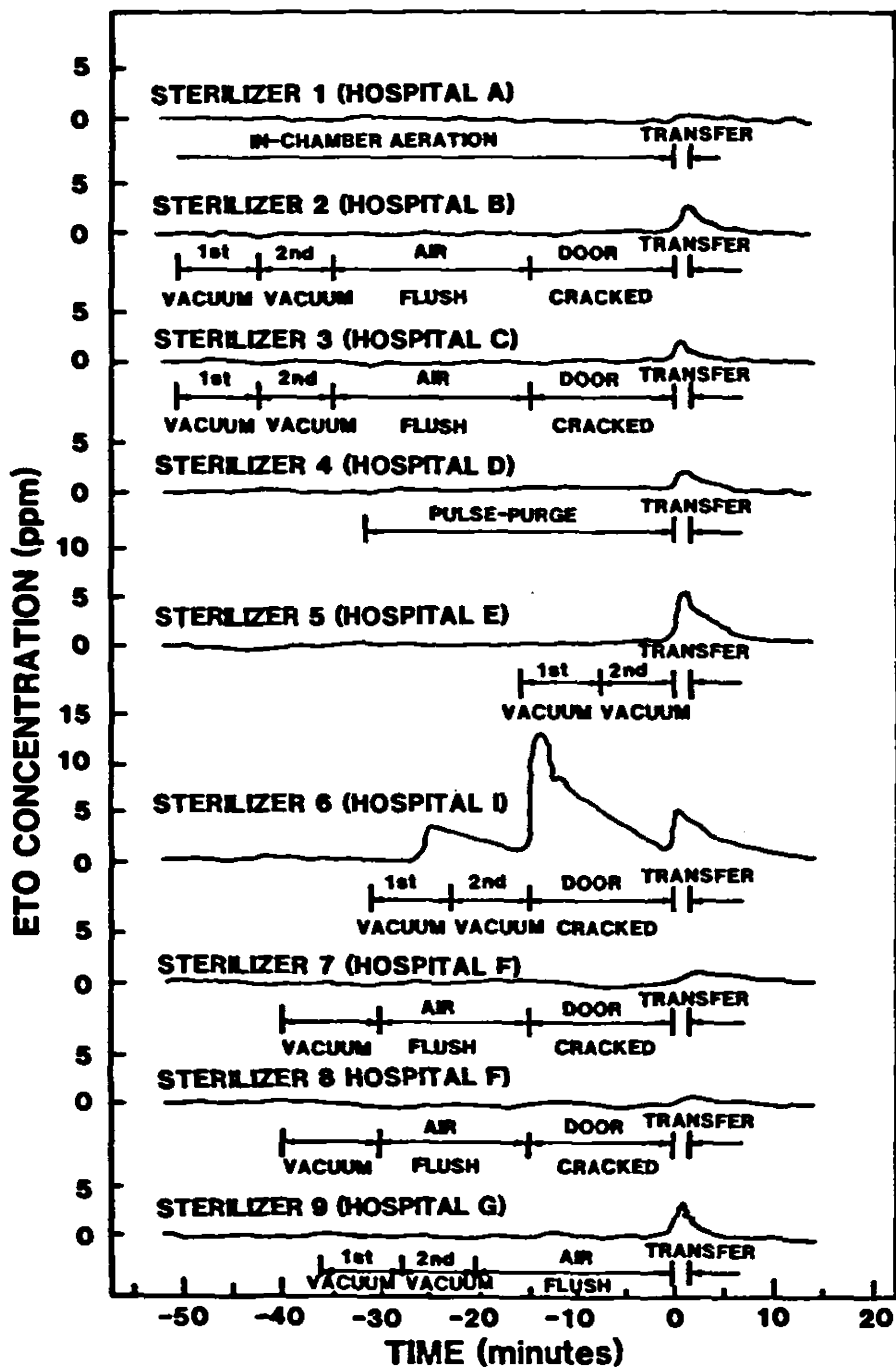

Figure 14. Representative infrared analyzer responses.

Table 7. Results from the infrared analyzer tracings.

| Sterilizer | Number of Samples | Area under curve ppm-min | Average Concentration ppm |
|------------|-------------------|--------------------------|---------------------------|
| 1          | 3                 | 0.5                      | 4.3                       |
| 2          | 9                 | 2.0                      | 8.1                       |
| 3          | 6                 | 0.8                      | 3.2                       |
| 4          | 5                 | 0.7                      | 2.9                       |
| 5          | 3                 | 2.3                      | 25.2                      |
| 7          | 6                 | *                        | *                         |
| 8          | 6                 | *                        | *                         |
| 9          | 10                | 1.3                      | 10.1                      |
| 6          | 6                 | 0.8                      | 13.5                      |

\* Peak too small to be distinguished from base line fluctuations.

**Table 8. Summary of local exhaust ventilation values.**

| <b>Sterilizer</b> | <b>Distance above Sterilizer inches</b> | <b>Slot Area ft<sup>2</sup></b> | <b>Slot Velocity ft/min</b> | <b>Volume Flow Rate cfm</b> |
|-------------------|---|---------------------------------|-----------------------------|-----------------------------|
| 1                 | 2                                       | 0.17                            | 620                         | 105                         |
| 2                 | 2                                       | 0.17                            | 530                         | 90                          |
| 3                 | 2                                       | 0.17                            | 800                         | 135                         |
| 4                 | 17                                      | 1.4                             | 110                         | 150                         |
| 5                 | 18                                      | 3.9                             | 115                         | 450                         |
| 7                 | 0                                       | 0.16                            | 210                         | 35                          |
| 8                 | 0                                       | 0.16                            | 190                         | 30                          |
| 9                 | 2                                       | 0.17                            | 575                         | 95                          |
| 10                | 25                                      | 2.2                             | 165                         | 360                         |
| 11                | 25                                      | 2.2                             | 80                          | 170                         |

Table 9. Summary of general ventilation values.

| Hospital | Room                     | Volume<br>Flow Rate<br>cfm | Room<br>Volume<br>ft <sup>3</sup> | Flow rate to<br>Room Vol. Ratio<br>hr <sup>-1</sup> |
|----------|--------------------------|----------------------------|-----------------------------------|---|
| A        | clean room               | 700                        | 5400                              | 8   |
| A        | mechanical access room   | 1250                       | 590                               | 127   |
| B        | clean room               | 1250                       | 9100                              | 8   |
| B        | mechanical access room   | 1000                       | 2500                              | 24  |
| C        | clean room               | 1750                       | 12000                             | 9   |
| C        | mechanical access room   | 120                        | 1700                              | 4   |
| D        | clean room               | 640                        | 7100                              | 5   |
| D        | mechanical access room   | 1000                       | 1300                              | 46  |
| E        | clean room               | 1100                       | 5000                              | 13  |
| E        | mechanical access room*  | 500                        | 1600                              | 19  |
| E        | mechanical access room** | 2000                       | 1600                              | 75  |
| F        | isolation room           | 230                        | 750                               | 18  |
| G        | clean room               | 1900                       | 9600                              | 12  |
| H        | isolation room           | 530                        | 760                               | 42  |
| I        | clean room               | 1750                       | 12000                             | 9   |
| I        | mechanical access room   | 300                        | 1700                              | 11  |

\* emergency exhaust off

\*\* emergency exhaust on



## Work Practices

Many factors affecting exposure are related to work practices. Those thought to be most significant in terms of exposure to EtO are compiled in Table 10. About half the hospitals used the door-cracked period. Likewise, about half of the hospitals -- although not the same ones -- used carts exclusively to load and unload the sterilizer. Generally less than 1 minute was required to transfer a load to an aerator. Only a few of the load transfers were completed by pushing or walking behind the load for an appreciable distance, and only one involved more than 10 seconds of close contact, as judged by the researchers while reviewing the videotapes.

Table 10. Summary of work practice parameters.

| Hospital | operator | door-cracked period | mode of transfer | transfer time minutes* | motion of transfer | contact sec* |
|----------|----------|---------------------|------------------|------------------------|--------------------|--------------|
| A        | a        | no**                | cart/cart        | **                     | pull               | **           |
|          | b        | no**                | cart/cart        | **                     | pull               | **           |
| B        | c        | yes                 | cart/basket      | 1.0                    | pull/swing         | ***          |
|          | d        | yes                 | cart/basket      | 1.5                    | pull/swing         | ***          |
| C        | e        | yes                 | cart/cart        | 0.5                    | push               | 4            |
|          | f        | yes                 | cart/cart        | 0.4                    | pull               | 2            |
|          | g        | yes                 | cart/basket      | 0.9                    | pull/swing         | 5            |
|          | h        | yes                 | cart/cart        | 1.2                    | pull               | 5            |
| D        | i        | no                  | basket/basket    | 0.9                    | pull/swing         | 6            |
|          | j        | no                  | basket/basket    | 0.2                    | pull/swing         | 4            |
| E        | k        | no                  | cart/cart        | ***                    | ***                | ***          |
|          | l        | no                  | cart/cart        | 1.1                    | push               | 5            |
|          | m        | no                  | cart/cart        | 0.7                    | swing/push         | 6            |
|          | n        | no                  | cart/cart        | 1.2                    | swing/push         | 7            |
| F        | p        | yes                 | basket/basket    | 0.1                    | down****           | 3            |
|          | q        | yes                 | basket/basket    | 0.1                    | down               | 3            |
|          | r        | yes                 | basket/basket    | 0.1                    | down               | 3            |
|          | s        | yes                 | basket/basket    | 0.1                    | down               | 5            |
|          | t        | yes                 | basket/basket    | 0.1                    | down               | 6            |
| G        | u        | no                  | basket/basket    | 0.4                    | swing              | 2            |
|          | v        | no                  | basket/basket    | 0.3                    | swing/push         | 14           |
| H        | w        | yes                 | basket/basket    | 0.3                    | swing              | 3            |
| I        | x        | yes                 | cart/basket      | 0.4                    | pull               | 3            |
|          | y        | yes                 | cart/cart        | 0.4                    | pull               | 1            |
|          | z        | yes                 | cart/cart        | 0.3                    | pull               | 4            |

\* geometric mean if more than one value

\*\* no load transfer, aeration performed in the sterilizer

\*\*\* no value obtained

\*\*\*\* for one load, operator held basket on arm for a few seconds while opening aerator door

## DISCUSSION OF CONTROLS

Because all of the sampled full-shift exposures were less than the 0.5 ppm, and most were less than 0.1 ppm, it should be expected that good controls were present in the hospitals surveyed. It is less obvious which controls were most responsible for the low exposures.

### CYCLE MODIFICATIONS

EtO concentrations in the sterilizer during sterilization are greater than 200,000 ppm. Depending on the nature of the final chamber evacuation phase, concentrations in the chamber when the door is first opened may range from 40 to 4,000 ppm. Reducing the chamber concentration is an effective way to control the amount of EtO released to the room and the local concentration that the operator is exposed to during the load transfer. This reduction may be accomplished in various ways: deep-vacuum purges, a "pulse-purge" cycle, closed-door air flushes, and a door-cracked period. Although the effectiveness of each method varies, each of these methods is theoretically capable of reducing the chamber concentration by over 99 percent if performed long enough or often enough. Usually, a combination of these methods is used. Such is the case with "in-chamber aeration," which involves leaving the load in the sterilizer and subjecting it to a series of vacuum cycles and closed-door air flushes for the duration of the aeration period.

The concentration measured in the sterilizer just before the door is opened fully to transfer the load is indicative of the effectiveness of the evacuation cycles at reducing the quantity of EtO which could be released into the workplace. Table 11 shows that all but two of the sterilizers had average chamber concentrations less than 300 ppm. One of the sterilizers with a concentration less than 15 ppm featured in-chamber aeration. Another in this low group had a pulse-purge cycle. The others used a door-cracked period and, in some cases, also a closed-door air flush.

For the two sterilizers with the higher concentrations, the loads were pulled immediately after the end of the evacuation cycles without a 15-minute door-cracked period. One of these, which had an average chamber concentration of 360 ppm, had a 20-minute closed-door air flush period after the two deep vacuum cycles. The other, whose average chamber concentration was 2,800 ppm had no additional cycles other than two deep vacuum cycles.

Of the four sterilizers in the low group which used a combination of vacuum purges, air flush cycles, and a door-cracked period, three were measured to have chamber concentrations of less than 100 ppm when the door was opened to transfer the load. (There were no chamber concentrations measurements for the fourth sterilizer.)

**Table 11. Comparison of the operator's short-term exposure-dose to the chamber concentration when the door is opened to remove the load.**

| <b>Sterilizer</b> | <b>Door-open concentration*<br/>ppm</b> | <b>Operator short-term exposure-dose*<br/>ppm-min</b> |
|-------------------|---|---|
| 8                 | 6                                       | 0.32  |
| 1**               | 11                                      | 0.18**  |
| 7                 | 17                                      | 0.72***   |
| 11                | 32                                      | 0.75  |
| 3                 | 98                                      | 0.57  |
| 10                | 130                                     | 1.91  |
| 4                 | 270                                     | 2.93  |
| 6                 | 280                                     | 3.31  |
| 9                 | 360                                     | 1.7****   |
| 5                 | 2800                                    | 5.43  |

\* Geometric mean if more than one sample

\*\* In-chamber aeration used for all sampled loads.

\*\*\* Includes value involving poor work practices.

\*\*\*\* Relatively strong air current flowed from the ceiling to the floor in front of the sterilizer.

Table 11 shows that the rank order of the operator short-term exposure is almost identical to the rank order of the chamber concentration when the door was opened to transfer the load. The values for one of the primary exceptions (Hospital F, Sterilizer 7) were skewed by one run characterized by almost no detectable EtO in the chamber when the door was opened and poor work practices during the load transfer. Recalculating the averages for this sterilizer without this run lowers the operator exposure value to 0.47 ppm-min and increases the chamber concentration value to 34 ppm, bringing it more in line with the other sterilizers at the top of the list. For the other exception (Hospital G), air flowed down through the area in front of the sterilizer, resulting in low operator exposures and area concentrations in front of the sterilizer despite the relatively high chamber concentrations. (This latter situation is discussed in the door ventilation section.)

### Deep-Vacuum Purges

Of all the mentioned individual techniques, deep vacuum purges are among the most effective. The chamber concentration is reduced by first removing most of the EtO from the chamber (typically down to a gauge pressure of -0.9 atm). The reduction of concentration occurs when the reduced quantity of EtO is diluted by allowing clean air to flow into the chamber, replacing that which was evacuated.

The typical implementation of this technique is to draw one or two deep vacuums at the end of sterilization. Theoretical calculations (based on the ideal gas law assuming an empty chamber) predict, and survey results confirm, that evacuating the chamber to approximately 0.1 atmospheres (absolute pressure) and returning to atmospheric pressure would reduce the chamber concentration by approximately 90 percent for each vacuum cycle. The one hospital (E) for which the load was transferred to an aerator immediately following two vacuum purges had an average chamber concentration of approximately 2,800 ppm when the door was opened to transfer the load, a total reduction of 99 percent from the estimated chamber concentration during sterilization.

### Pulse-Purge Cycle

Because the concentration reduction due to a vacuum purge depends only on the pressures (assuming that chamber temperature is held constant), not on time; pulse-purge cycles -- a series of many (usually shallower) vacuum purges -- are theoretically more effective, achieving a concentration of only a few parts per million before the end of 15 cycles. Survey results indicate that overall, the pulse-purge cycle achieved a 99.9 percent reduction after 30 cycles; however, the end-of-cycle concentrations (approximately 300 ppm) were not as low as predicted from ideal gas law calculations.

### Closed-door Air Flush Period

The air flush is like a deep vacuum purge, except that the filtered air inlet is kept open so that air flows through the chamber. The effectiveness depends on the flow rate relative to the chamber size, the mixing of the flushing air with the chamber contents, and the duration. With all these variables, this

process is also difficult to model accurately. In one hospital (C), the addition of a 20-minute closed-door air flush period before the door was opened reduces the chamber concentration by over 80 percent from approximately 540 ppm to 80 ppm. At another hospital (G) which removed the load immediately after a 20-minute air flush (preceded by two deep vacuum purges) chamber concentrations averaged approximately 360 ppm. As it is not known what the chamber concentration was at the start of the air flush, the actual percent reduction cannot be calculated. Assuming a 90 percent reduction for each of the vacuum purges indicates that the air flush period reduced the chamber concentration an additional 65 percent.

#### Door-Cracked Period

The door-cracked period relies solely on diffusion and airflow driven by convection of air from the chamber to reduce the chamber concentration. This depends on the temperature of the air in the chamber, the amount the door is cracked, the duration, and to some extent on the presence of ventilation above the sterilizer door. Survey results have shown that a door-cracked period reduces the chamber concentrations by approximately 64 to 97 percent for all loads. The hospitals which used only a door-cracked period following two vacuum purges had chamber concentrations for the test loads ranging from 32 to 275 ppm.

With few exceptions, low operator exposures during the load transfer were coincident with low concentrations in the chamber when the door was opened to transfer the load, and sterilizers for which a door-cracked period was used had lower average chamber concentrations. All sterilizers for which a door-cracked period was used, except for Sterilizer 2 (for which chamber concentration data was not obtained), had average chamber concentrations less than 200 ppm. The reduction of chamber concentration during the door-cracked period ranged from 74 to 99 percent. (This includes sterilizers which had other cycle modifications.) In this procedure, the door should not be opened beyond the distance which the local exhaust ventilation above the door can capture air rising from the sterilizer -- this implies that this ventilation should be installed. A 15-minute door-cracked period is adequate; on the few occasions that the door was cracked for 20 to 30 minutes, the chamber concentration was not reduced significantly further. Workers should be kept away from the area in front of the sterilizer during this period.

#### In-Chamber Aeration

The exposure control advantages of having aeration take place in the sterilizer instead of having to transfer the load to an aerator should be obvious in terms of not only the lowest possible concentration of EtO in the chamber when the door is opened but also the lowest quantity of EtO residual "on" the items when the load is removed from the sterilizer. Survey data confirms that this technique results in essentially no detectable exposure to EtO. The one hospital surveyed which used this technique had exposures and area concentrations indistinguishable from the field blanks. Even the gas bag samples analyzed on the portable GC were not detectable at the standard calibration level used in the other surveys. Thus, even short-term exposures

(for approximately a minute) to remove the load from the sterilizer were less than 0.2 ppm.

#### STERILIZER DOOR

Any meaningful mathematical comparison of sterilizer door ventilation with exposure is complicated by not knowing the quantity of EtO which would reach the sampling location if there were no LEV. However, with the exception of the load in Hospital F during which undesirable work practices were used, the sterilizers with the highest operator's short-term exposures were the ones using the door-cracked period with no ventilation or the hospitals which took the load out of the sterilizer immediately and had a local exhaust hood far above (18 to 20 inches) to top of the sterilizer door. Similarly, the data show that the three highest operators' long-term exposures were for the three sterilizers which either had no ventilation above the door or a hood approximately 2 feet (rather than a few inches) above the door.

The size of the hood and the required flow rate depend on the location of the hood. When the sterilizer door is first opened, the air is hot (100 to 130°F), and it rises because it is less dense than the surrounding (cooler) air. The vertical velocity may be as high as 100 ft/min close to the control panel. As it rises, the flow entrains more air, and the ventilation hood needs to exhaust at least as much air as is rising up to it or some air (containing EtO) will not be captured. As more air is entrained, the plume of rising air widens and the distance out from the face of the sterilizer that air must be captured increases.

Referring to Figure 15, the plume of air rising from the sterilizer door, partially opened to a distance,  $d$ , would be expected to thicken by approximately one-third the distance,  $h$ , from the top of the door to the edge of the hood. If the hood is close to the top of the door, the hood need not be large. However, if the hood does not cover the plume of air, the flow rate should be sufficient to generate a capture velocity at the outer margin of the plume so that all of the air rising from the sterilizer door opening is redirected into the hood. As the door is opened further, capturing all the air becomes more difficult.

For a slot hood located no more than 3 inches above the door, the volumetric flow rate should be:

$$Q = 280(LD)$$

where:  $Q$  is the volumetric flow rate, cfm, of exhausted air,

$L$  is the length, ft, of the slot,

and  $D$  is a distance ( $d + h/3$ ), ft, out in front of the sterilizer.

It is not necessary that the hood extend out from the front panel as is shown in Figure 16. As long as the above ventilation criteria are met and the door is opened approximately 2 inches, all EtO escaping from the sterilizer during the door-cracked period should be captured.

If the hood is located more than 3 inches above the sterilizer door, it should extend as far as the buoyant plume of air. Functioning as a recovery hood, a

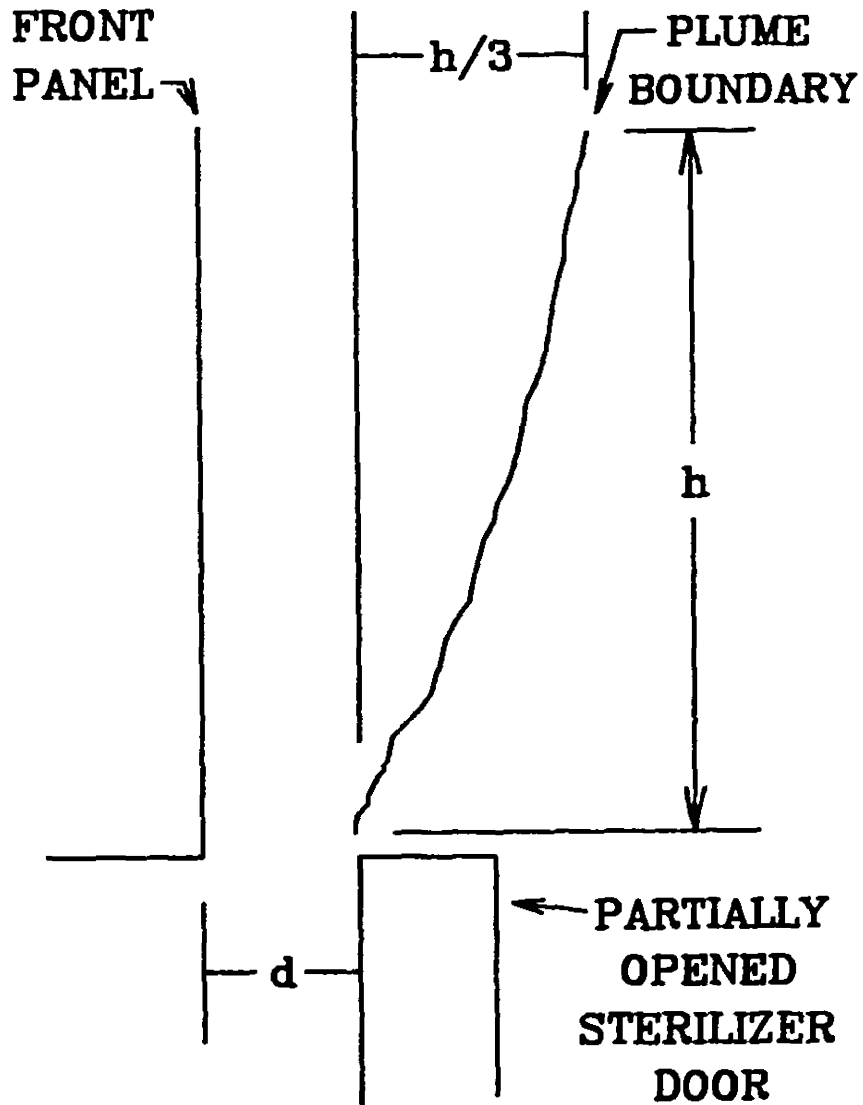

Figure 15. A plume of hot air escaping from a partially opened sterilizer door will spread out from the front panel about one-third the distance it has risen.



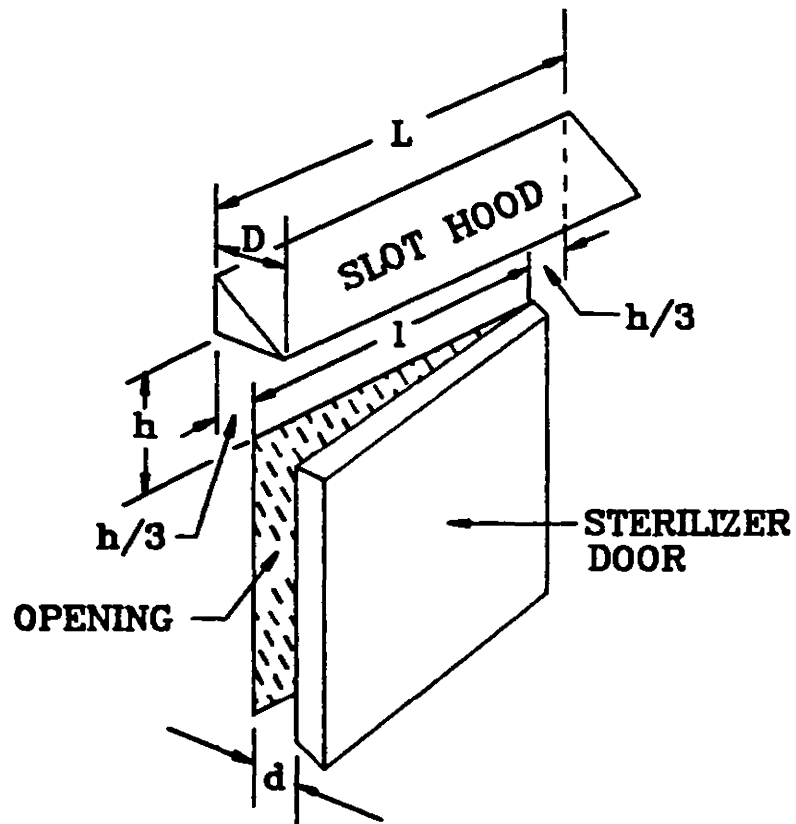

Figure 16. A slot hood placed no more than 3 inches above the sterilizer door can be used to capture the EtO escaping from the chamber during the door-cracked period. (See text for a discussion of the appropriate values for the variables.)

canopy hood (shown in Figure 17) needs to develop a volumetric flow rate somewhat longer than the plume of air rising into it. Therefore, the flow rate of air exhausted should be:

$$Q = 100(LW)$$

where: Q is the volumetric flow rate, cfm, of air exhausted,  
L is the length, ft, of the hood,  
and W is the width, ft, of the hood.

For a canopy hood, the width, W, should be the distance, d, that the door will be opened (i.e., 2 inches) plus the amount the plume will spread in front of the sterilizer:

$$W = d + h/3$$

In both cases, the length, L, of the hood should be the width, l, of the door plus twice the amount the plume will spread on each side of the door:

$$L = l + 2(h/3)$$

Based on observations during the surveys, opening the door 2 inches is sufficient to yield an adequate reduction of the chamber concentration during the 15-minute door-cracked period. Comparing the two different configurations for a typical case of a sterilizer with a door 2 feet wide, the exhaust required for the slot (approximately 2 inches above the door) would be 130 cfm. For a hood above the top of the control panel (approximately 24 inches above the door), 280 cfm would be required. These results are consistent with the values measured during this study.

Local ventilation above the door is most effective only in controlling the EtO released during a door-cracked period. However, due to the limited distance that the capture zone of a typical exhaust hood extends out from a sterilizer, this method is less effective during the load transfer. Moreover, the action of pulling the load from the sterilizer acts like a piston, drawing much of the air in the chamber up to 4 feet away from the sterilizer. The movement of the operator performing the load transfer and the prevailing air currents in the room add to the mixing of the chamber emissions to the air in front of the sterilizer and aerator and to the dispersion of EtO throughout the room. Exhaust ventilation which captures air up to only a few inches in front of the sterilizer has little effect in this situation.

One airflow pattern which was effective in the region beyond a few inches from the face of the sterilizer was a supply air inlet which created an air current moving down through the region in front of the sterilizer, moving much of the EtO-contaminated air out of the region and showering the operator with relatively clean air. The hospital in which this was found had one of the best (percent) ratios of average short-term sterilizer area concentration relative to the chamber concentration when the door was opened to transfer the load. The capture of air in front of the sterilizer appeared to not be as good at this hospital, but the overall control of EtO emissions was. During the one run when a deflector was added to disrupt the downflow air pattern and improve the capture distance of the local exhaust ventilation above the

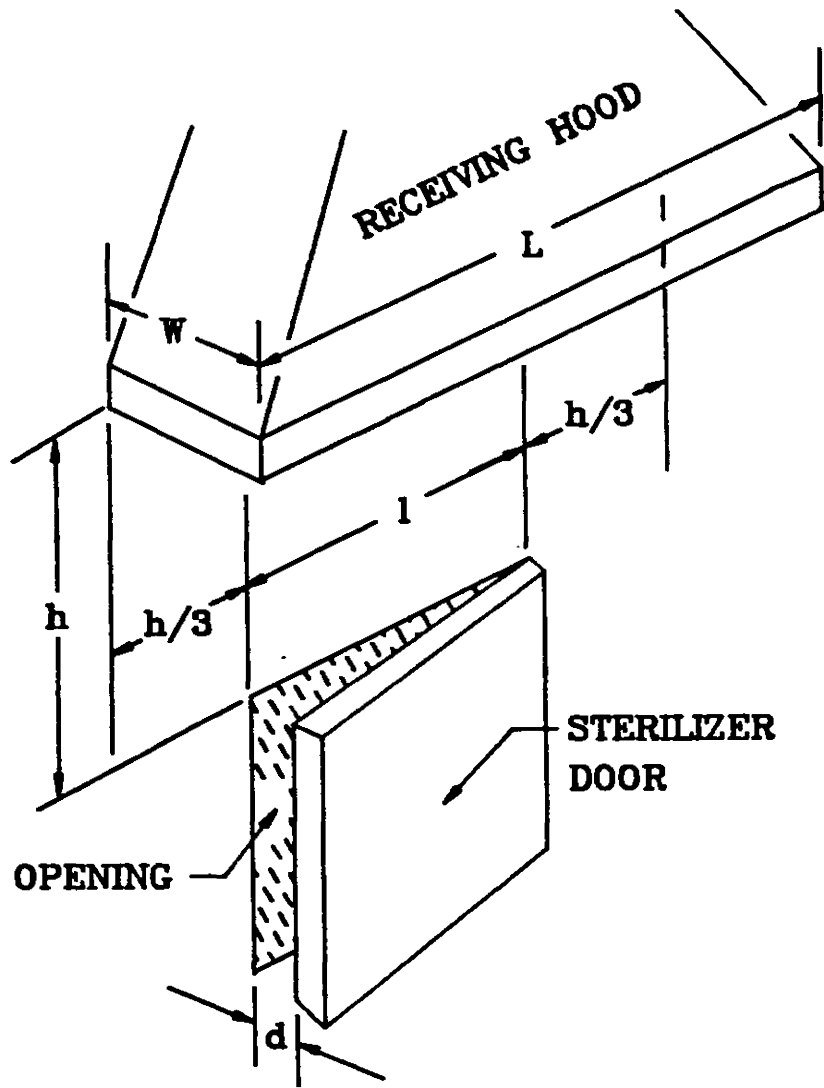

Figure 17. A canopy hood above the sterilizer door can be used to exhaust the EtO which rises in front of the sterilizer during the door-cracked period. (See text for a discussion of the appropriate values for the variables.)

sterilizer door, both the operator short-term exposure and the short-term area concentration in front of the sterilizer were significantly higher (although still within NIOSH recommended limits). This hospital did not use a door-cracked period.

#### VENTILATED AIR GAP ENCLOSURE

During the evacuation phase of a 12:88 sterilizer, 90 to 99 percent of the EtO in the chamber is discharged through the water-sealed vacuum pump. Surrounding the antisiphon air gap with a ventilated enclosure is an effective way to control the considerable quantity of EtO which passes through the sterilizer evacuation line from the water-sealed vacuum pump to the drain. Since the source can be completely enclosed, the required flow rate is that required to contain the EtO, i.e., the amount required to maintain a flow of air in through the openings of the enclosure when the vacuum pump is running. The openings are required to provide an escape for water which might back up from the floor drain and to allow air to enter the ventilation without causing a large pressure drop. On more than one survey in this study, an enclosure marketed by one of the sterilizer manufacturers, with two openings approximately 5 in<sup>2</sup> each, was observed to be effective when ventilated by approximately 50 cfm. One "homemade" enclosure drawing only 10 cfm through a small (approximately 1 in<sup>2</sup>) opening did not prevent EtO from escaping.

In some hospitals, even though ventilated enclosures had been installed, EtO escaped via other routes. One route was the junction of the floor drain and the discharge line from the ventilated enclosure. Another route was the lines connecting the leak cups on the water-sealed vacuum pumps to the floor drain. Table 12 shows that average mechanical access room concentrations are related to the drain controls (including secondary leaks) and are seemingly unrelated to the general ventilation for the mechanical access room. A statistical model (SAS<sup>®</sup> PROC GLM) showed that the mechanical access room concentrations for the unventilated drain air gap were significantly ( $R^2=.96$ ,  $F=134$ ,  $Pr=0.0001$ ,  $df=20$ ) greater than for the ventilated enclosure with an unsealed drain and that the concentrations for the unsealed drain were significantly greater than for the sealed drain.

#### SUPPLY CYLINDERS

The compressed-gas cylinders are a potential source of tremendous magnitude because they may contain as much as 7,000 grams of EtO, and the supply line from compressed gas cylinders contains liquid EtO under pressure. If this pressure is not relieved, the liquid EtO can spray the worker changing the cylinder and cause skin burns and/or irritation. To protect the maintenance worker changing the EtO supply cylinders, the supply line should be fitted with a valve to allow the contents of the line to be vented outside the building instead of into the space around the cylinders. It is acceptable and convenient to vent this valve to the ventilated enclosure for the sterilizer drain.

Even if the worker is not sprayed, the emitted EtO is an inhalation exposure hazard. Local exhaust ventilation is needed to capture EtO which might escape from the supply line connection to the EtO cylinders either during the

**Table 12. Sterilizer discharge line/drain controls**

---

| <b>Hospital</b> | <b>Drain Controls</b>       | <b>Ventilation/<br/>Room Volume<br/>ratio</b> | <b>Mechanical<br/>Access room<br/>Concentration<br/>ppm</b> |
|-----------------|-----------------------------|---|---|
| <b>C</b>        | <b>Sealed Ventilation</b>   | <b>4</b>                                      | <b>0.28</b>   |
| <b>D</b>        | <b>Sealed Ventilation</b>   | <b>45</b>                                     | <b>0.32</b>   |
| <b>C*</b>       | <b>Unsealed Ventilation</b> | <b>4</b>                                      | <b>2.3</b>  |
| <b>I</b>        | <b>Unventilated</b>         | <b>8</b>                                      | <b>9.1</b>  |

---

\* Same hospital.

cylinder change operation or due to a leaky connection. If designed with a hinged Plexiglas® panel, as illustrated in Figure 18, the worker's face will also be protected from EtO which might spray from the supply line when disconnecting it. The flow rate should be at least 100 cfm per square-foot of open area with the hinged panel in the down position.

One hospital placed the cylinders in a well-ventilated mechanical access room, with local exhaust ventilation above the cylinders. A cylinder change was sampled in this hospital. During the approximately 8 minutes required to complete the change, the concentration above the cylinders was approximately 1 ppm. The samples taken to determine the exposure of the person changing the cylinder were indistinguishable from the field blanks. During a cylinder change with neither ventilation nor a venting valve to relieve EtO trapped under pressure in the supply line, EtO sprayed from the connection point when the supply line was disconnected from the cylinder and the area concentration was measured to be approximately 100 ppm.

A respirator will be needed in case of an emergency situation when working with the EtO supply lines or cylinders. For situations where the worker encounters an unknown concentration of EtO or in an emergency situation, NIOSH recommends a compressed air, open circuit self-contained breathing apparatus with full facepiece.<sup>70</sup> Nitrile- or butyl-rubber gloves and a face shield will protect the worker from a possible spray of liquid containing EtO when the supply line is disconnected.

#### RELIEF VALVE

Sterilizers which are pressurized during the sterilization dwell period are fitted with overpressure relief valves. The valve is designed to open if the pressure inside the chamber exceeds a set limit, releasing the contents of the chamber to relieve the overpressure condition. The only time the chamber is pressurized is during the sterilization dwell period. For an 8.8-ft<sup>3</sup> sterilizer, approximately 50 grams of EtO could be emitted from the relief valve if it opened to relieve an overpressure condition.

#### MECHANICAL ACCESS ROOM/STERILIZER CABINET VENTILATION

With adequate (secondary) ventilation of the sterilizer enclosure (mechanical access room or sterilizer cabinet), EtO leaks inside the enclosure would not expose the sterilizer operator or other workers in the clean room. However, if this discharged EtO is not controlled, it can be reintroduced into the workroom air and increase the amount the workers are exposed to.

Ventilation for the enclosure around the body of the sterilizer, whether it be a cabinet or an equipment room (mechanical access room) is not as simple as merely applying exhaust ventilation at some point and expecting pressure differentials to control EtO emissions. The presence of the hot equipment complicates the airflow patterns.

Air does not always flow into a room with the same velocity at all openings. In fact, when heated processes are present in the room, air may actually flow out of vents and cracks in the walls near the top of the room if the

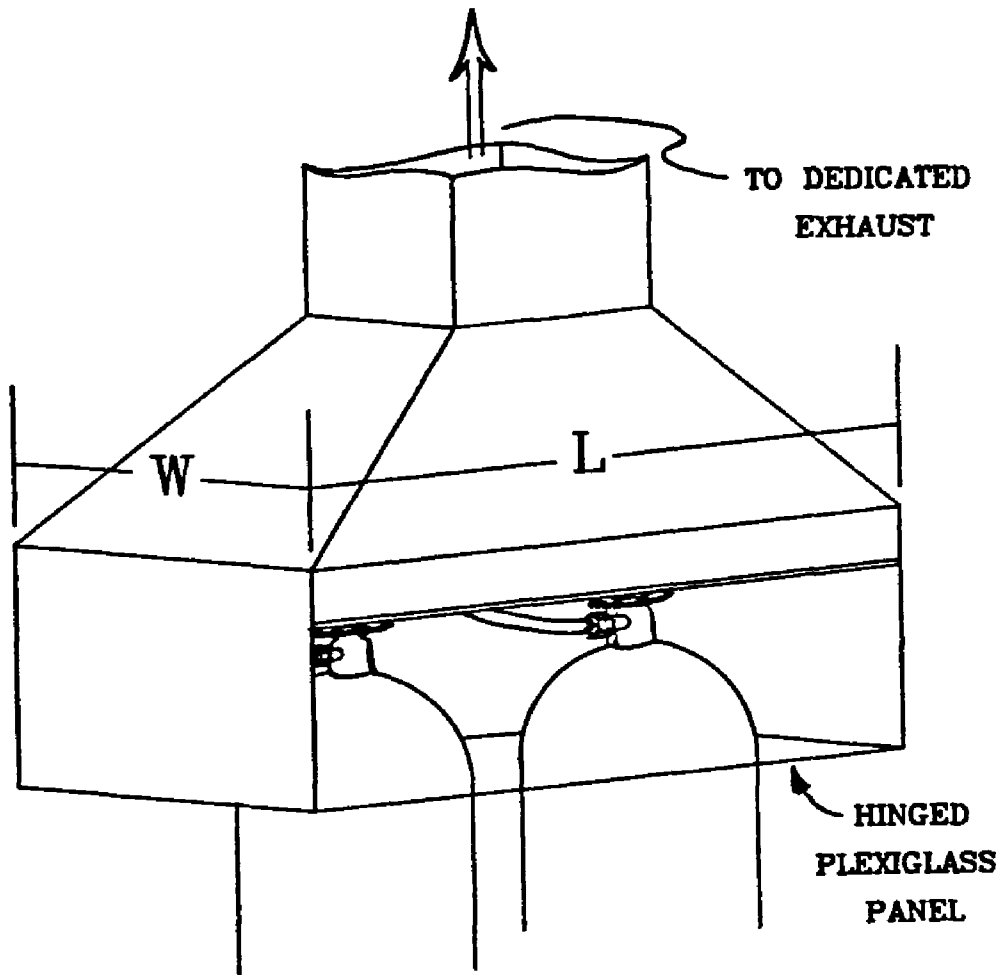

Figure 18. The recommended cylinder hood design features a hinged Plexiglas® panel which can be raised to remove the empty cylinder and slide in the new cylinder. In the down position, the panel protects the worker's face from spray while allowing the worker to see the connection point while the empty cylinder is being disconnected and then the new cylinder is connected to the supply line.

ventilation system does not exhaust enough air to handle the quantity of air rising to the ceiling due to thermal effects.

Using an equation for velocity of air flowing through an orifice at the top of an enclosure due to thermal head, a minimum exhaust flow rate can be calculated which assures that air does not leak out of the room.<sup>71</sup> For room temperatures not exceeding 93°C (200°F):

$$Q = 20(L H')^{1/3}(A)^{2/3}$$

where: Q = Minimum flow rate, ft<sup>3</sup>/min;  
L = Height of the hot air column, ft;  
H' = Sensible heat released to the air stream, Btu/min;  
A = Total area of vents, openings, and cracks, ft<sup>2</sup>.

The height of the air column is taken to be a nominal room height (unfinished ceiling) of 10 feet. Because of the cube root, halving this value only reduces the flow rate prediction by 20%, so using the actual value is not critical. Small gas sterilizers are electrically heated and release only 100 to 200 Btu/hour into the mechanical access room. Steam sterilizers and steam-heated gas sterilizers release 2,500 to 5,000 Btu/hour. Aerators are in between these ranges at approximately 1,500 Btu/hour. Typically, 0.5 to 1.5 ft<sup>2</sup> of open area is present for each sterilizer. Even with these values, the solution of the equation is complicated. For simplicity, the equation has been solved using representative values for the different types of equipment and mechanical access room parameters. These results and some accompanying discussion are presented in the Recommendations for mechanical access room/sterilizer cabinet ventilation.

If some ethylene oxide is released into the enclosure, the ventilation will reduce the concentration in time. The rate of decrease of concentration of a contaminant once further generation has ceased is given by the following equation:<sup>72</sup>

$$\ln \frac{C_2}{C_1} = - \frac{Q'}{kV} (t_2 - t_1)$$

where: C<sub>2</sub> = the concentration at time t<sub>2</sub>;  
C<sub>1</sub> = the concentration at time t<sub>1</sub>;  
Q' = the effective ventilation rate;  
V = the volume of the enclosed space.

The effective ventilation rate, Q', is equal to the actual ventilation rate, Q, divided by a design distribution constant, K, which is a value between 3 and 10 to correct for incomplete mixing. Since most sterilizer enclosures are small with good mixing due to thermal air currents, K can be assumed to be 3. The equation can be solved for Q:

$$Q' = \frac{3V}{(t_2 - t_1)} \ln \frac{C_1}{C_2}$$



The initial concentration,  $C_1$ , can be estimated by assuming the entire sterilizer contents escape into the mechanical access room.

#### DEDICATED EXHAUST

At least one overexposure situation has been attributed to a nondedicated exhaust system.<sup>36</sup> At this hospital, the overexposure was sufficient to elicit acute exposure symptoms. It was later discovered that the fan belt for the roof fan might have broken about the same time the symptoms were first noticed. However, evaluation of the ventilation system showed that the roof fan was also inadequately sized to exhaust the air supplied by the two auxiliary fans and still maintain the required exhaust ventilation at all of the original vents. This caused air containing EtO to be forced out of some of the exhaust vents when both auxiliary fans were running.

#### EtO DISCHARGE LOCATION

The discharge lines for the single-dose cartridge sterilizers are usually soldered copper vented directly outside the building. In one installation, the outlet was in a courtyard near windows and air-conditioning intakes. The two models of this type of sterilizer now being used are charged with 100 or 134 grams of EtO during sterilization. Most of this EtO is discharge during the evacuation cycles, and an exposure hazard would result if the discharged airstream reentered the building.

The reentry of exhausted EtO can cause an exposure hazard. Although considerable dispersion of the EtO in the ventilation discharge would occur within a few hundred feet of the discharge point, not much dilution would occur in the first 10 feet or so, especially in areas of mild air currents. Using Sutton's equation for atmospheric diffusion,<sup>73</sup> it is predicted that a discharge of 100 grams of EtO over a 10-minute period would create a concentration of approximately 175 ppm at a distance of 10 feet from the discharge point along the axis of the discharge stream. If this discharge stream were to reenter the building, it would deposit approximately 1 gram in the space entered. Such a quantity would create a temporary concentration of 20 ppm in a room 20 by 20 feet with an 8-foot ceiling.

#### GENERAL VENTILATION

In general, room ventilation rates did not seem to be related to levels of EtO in this study, although this may be due to the overall low levels of EtO emission. On one survey, no difference was noted in the airborne EtO concentrations as the number of "room air changes per hour" was increased from four to eight by increasing the amount of outside air supplied to the room. Furthermore, EtO exposures were controlled to less than 0.1 ppm when the ratio of ventilation rate ( $\text{ft}^3/\text{hour}$ ) to room volume ( $\text{ft}^3$ ) was four rather than the often recommended ten.

Area concentrations are more indicative of the effectiveness of general ventilation than are personal exposures; however, the area concentration in front of the sterilizer includes the effect of end-of-cycle/load transfer EtO emissions, which are related more to local exhaust ventilation. Therefore, an

**Table 13. Comparison of full-shift operator's exposures and area concentrations in front of the sterilizer with the ratio of the ventilation volume per hour to the room volume.**

| <b>Hospital</b> | <b>Ventilation/<br/>Room Volume<br/>ratio</b> | <b>Sterilizer Area<br/>Concentration*<br/>ppm</b> | <b>Operator<br/>exposure*<br/>ppm</b> |
|-----------------|---|---|---------------------------------------|
| <b>B</b>        | <b>8</b>                                      | <b>0.02</b>                                       | <b>0.03</b>                           |
| <b>C</b>        | <b>9</b>                                      | <b>0.04</b>                                       | <b>0.04</b>                           |
| <b>I</b>        | <b>9</b>                                      | <b>0.31</b>                                       | <b>0.20</b>                           |
| <b>G</b>        | <b>12</b>                                     | <b>0.03</b>                                       | <b>0.03</b>                           |
| <b>F**</b>      | <b>18</b>                                     | <b>0.08</b>                                       | <b>0.01</b>                           |
| <b>H**</b>      | <b>41</b>                                     | <b>0.38</b>                                       | <b>0.04</b>                           |

\* Geometric mean if more than one sample

\*\* Gas sterilization equipment located in a separate room entered only to load, unload, and check on the operation of the sterilizers and aerators.

"ambient" or background concentration is calculated by subtracting the quantity (ppm-min) of EtO collected by the sampler during the short-term sample from the (full-shift) total quantity sampled and dividing by the full-shift sample time minus the short-term sample time. As is shown in Table 13, the calculated ambient concentration in front of the sterilizer and the concentration to which the operator was exposed during the day were not well correlated to the general ventilation expressed as a ratio of cubic feet per hour divided by the room volume (ft<sup>3</sup>) as well as to each other. In fact, not only was a low correlation ( $r^2$ -value less than 0.25) obtained from statistical modeling, but also what little correlation there was had a negative slope.

The general ventilation system of most of the hospitals survey recirculated some of the air exhausted from the sterilizer area. In some cases, this recirculated air stream could not be shut off. In the event of an EtO emergency, it would be desirable to have all the air exhausted from the sterilizer area directly outside the building. If it were not, EtO could be spread throughout the hospital.

#### ISOLATION/SEPARATION

The ratio of the operator's ambient full-shift minus short-term exposure to the ambient concentration in front of the sterilizer could be indicative of the effect of separating the operator from the sterilizer during the (large) portion of the shift not spent unloading the sterilizer. The pertinent data to examine this relationship are shown in Table 14. Examining this data, it can be seen that the four sterilizers which were located in separate (isolation) rooms were among the five sterilizers with the lowest values of this ratio. Also, the four highest ratio values were for four of the five sterilizers with the highest chamber concentrations when the door was opened to remove the load. Using the SAS<sup>®</sup> procedure (PROC GLM<sup>®</sup>) to quantify the appropriateness of a general (linear) statistical model to fit the data, it was found that this ratio had the highest concentration ( $1^2=0.32$ ) to the limiting of operator exposure of any of the factors investigated.

The data indicate that hospitals F and H, which had isolation rooms, had low operator short-term exposures. This is especially noteworthy in the case of hospital H, which had relatively high sterilizer area concentrations. However, it is not certain if this was because of or in spite of the isolation.

#### WORK PRACTICES

##### Load Transfer

Due to dispersion, the concentration of EtO decreases with increasing distance from the source and the passing of time. Although not directly proportional, it is expected that worker exposure increases with increasing time in contact with the load. However, no quantitative relationship was found between these factors in this study.

EtO seems to offgas from the newly sterilized load relatively slowly compared to the usually short time (30 seconds to 2 minutes) required to transfer a

**Table 14. The relationship of the presence of a sterilizer isolation room and the chamber concentration when the door was opened for the load transfer to the ratio of the sterilizer operator's ambient exposure to the sterilizer area ambient concentration.**

| <b>Sterilizer</b> | <b><u>Operator Exposure</u><br/>Area Concentration</b> | <b>Isolation<br/>Room</b> | <b>Door-Open Chamber<br/>Concentration, ppm</b> |
|-------------------|--|---------------------------|---|
| 7                 | 0.10   | Yes                       | 17  |
| 8                 | 0.13   | Yes                       | 6   |
| 4                 | 0.21   | No                        | 270   |
| 11                | 0.23   | Yes                       | 32  |
| 10                | 0.66   | Yes                       | 130   |
| 6                 | 0.80   | No                        | 280   |
| 9                 | 1.17   | No                        | 360   |
| 5                 | 2.35   | No                        | 2800  |

load to an aerator. However, high concentrations can develop close to the load. Two samples taken above a load being transferred to an aerator at one hospital showed concentrations ranging from 100 ppm to less than 10 ppm as the distance from the load changed from a few (approximately 2) inches to approximately 1 foot. During the actual transfer of the load to an aerator, the local exhaust hood cannot be expected to control EtO emissions from the load. The operator's exposure can increase substantially if the operator comes in close contact with the load for more than a few seconds. During one survey, an elevated short-term exposure -- five to ten times higher than the average for that survey -- occurred when a basket of newly sterilized items was held on the operator's arm while the aerator door was opened. Although it was not shown that pulling the load or walking with the load to the side resulted in significantly lower exposures, such practices seem to make good sense.

The rate of offgassing and the amount of EtO given off will be even less if the EtO concentration in the chamber is lowered before the load is removed. Some hospitals followed the sterilizer manufacturers' recommended practice of opening the door a few inches at the end of the cycle and leaving the room for 15 minutes before unloading the sterilizer. Following this work practice, the average concentration inside the chamber before opening the door fully to transfer the load was approximately 90 ppm. Although this value was highly variable, ranging from 38 to 150 ppm, the average additional reduction of more than 85 percent from the concentration at the start of the waiting period indicates that the door-cracked period was effective.

#### Air Out Chamber Before Cleaning

The sterilizer chamber can retain a significant quantity of EtO. For Hospital G, in which the load was transferred without a door-cracked period, the concentration measured inside the chamber a few hours after the load transfer averaged over 200 ppm. At another hospital in which, although a door-cracked period was not used prior to load transfer, the door was left partially open overnight, the concentration inside the chamber prior to cleaning averaged 0.56 ppm, and the exposure to the operator while cleaning the sterilizer chamber averaged 0.27 ppm.

## CONCLUSIONS

EtO exposures from hospital sterilizers can be controlled to not exceed a ceiling limit of 5 ppm and to average less than 0.1 ppm for a full shift. All but one of the hospitals surveyed in this study had short-term exposures less than 2 ppm and full-shift exposures less than 0.1 ppm.

The extent of control needed by a hospital will depend on a number of factors such as the composition and size of the sterilized load, the location of the sterilizer and the time constraints on sterilization, the type of sterilizer and the types of controls selected, and the level to which EtO exposures are to be controlled. In-chamber aeration, which substantially eliminates any exposure, is the best control. When it is not possible to fully use in-chamber aeration, the results of this study suggest that cycle modifications, local ventilation above the sterilizer door, and a ventilated enclosure around the sterilizer drain are the next most effective techniques for reducing exposures. Other controls -- such as a well-ventilated equipment room, cylinder station ventilation, and sterilizer isolation rooms -- provide additional benefit. In this study, general ventilation did not seem to be as important as other control techniques in controlling EtO exposures. EtO and ventilation sensors and alarms and proper emergency response procedures are essential to every control system.

## CYCLE MODIFICATIONS

In-chamber aeration resulted in EtO emissions/exposures below detectable limits. When in-chamber aeration was not used, pulse-purge cycles and deep-vacuum purges were effective in reducing the emission of EtO from the sterilizer and the exposure to the operator during the load transfer. A 15-minute door-cracked period reduced the concentration in the chamber before the door was fully opened by an average of 70 to 99 percent, regardless of the purge cycles which preceded it. Closed-door air flushes were observed to not be as effective as the vacuum purge cycles.

## STERILIZER DOOR VENTILATION

Local exhaust ventilation above the sterilizer door will capture EtO emitted from the partially open sterilizer door if the flow rate is adequate for the exhaust hood's location. The further above the door that the hood is located, the larger the hood needs to be to allow for spreading of the plume as it rises. Without local exhaust ventilation above the sterilizer door, the EtO in the chamber at the end of sterilization will disperse throughout the room.

## **VENTILATED AIR GAP ENCLOSURE**

If the discharge line of the sterilizer is not adequately controlled, a considerable quantity of EtO may be emitted during the evacuation cycle. Even if a ventilated enclosure is installed around the antisiphon air gap, if the junction with the floor drain or other openings in the line are not sealed, EtO may still escape. One possible route for EtO emission is a line connecting the leak cups on the water-sealed vacuum pump to the drain.

## **SINGLE-DOSE CARTRIDGE STERILIZERS**

The sterilizers which use single-dose cartridges and operate below atmospheric pressure do not have liquid drain junctions. However, hospital personnel could be exposed if the discharge lines (which are pressurized above atmospheric pressure during the purge cycles) leak or if the outlet is not properly terminated outside the building. Also, if the cartridge-well is outside the sterilizer and the single-dose cartridge is not seated properly or there is some malfunction, workers could be sprayed and exposed to the EtO vapors.

## **EtO DISCHARGE LOCATION**

The odor of EtO cannot be detected until concentrations reach approximately 700 ppm. Thus, workers may unknowingly be exposed. Such exposures may result from the reentry of EtO into buildings through heater or air conditioning intake vents. A small quantity of EtO can cause a potentially harmful concentration in the average size office or hospital room.

## **STERILIZER ISOLATION ROOMS**

Enclosing the sterilizers in a separate room should result in low personal exposures and area concentrations in the areas outside the enclosure or containment zone. However, it may expose the sterilizer operators to higher concentrations when in the isolation room. A sterilizer isolation room cannot be used as a substitute for other controls.

## **MECHANICAL ACCESS ROOM/STERILIZER CABINET VENTILATION**

Sterilizers supplied by compressed-gas cylinders are often recessed into a separate room (called a mechanical access room, equipment room, or recess room) which may or may not enclose all the potential EtO emission sources. These rooms are usually ventilated. This type of sterilizer may also be enclosed in a cabinet, which is usually not ventilated. There is always the possibility of incidental release of EtO in the enclosure. If the enclosure is inadequately ventilated, air containing EtO may escape into areas where employees work. Heat sources inside the enclosure tend to disrupt otherwise adequate ventilation.

Even if the mechanical access room ventilation is adequate, EtO released in the room could still be a problem for workers who must be in the room. Workers performing maintenance on other equipment in the mechanical access

room may be unaware of the potential for exposure to EtO during the purge cycle or if the overpressure relief valve should open.

#### SUPPLY CYLINDERS

A leak from the EtO supply lines or cylinders could release a considerable quantity of EtO. During the cylinder change operation, liquid EtO from the pressurized supply lines could spray the worker changing the cylinder when supply line is disconnected, creating both a skin hazard and an inhalation hazard.

#### RELIEF VALVE

For a 12:88 sterilizer, if the overpressure relief valve opens (at a set-pressure of 15 psig) approximately 100 gm of EtO could be released, enough to create a concentration of over 2,000 ppm in a 1,000-ft<sup>3</sup> room. This would create a hazardous situation.

#### DEDICATED EXHAUST

When an auxiliary fan is added to the sterilizer exhaust system to push air into the main exhaust duct, and a "dedicated" exhaust is not used -- i.e., there are other vents in the exhaust duct (which is almost always the case) -- EtO could be forced out of vents not exhausted by the auxiliary fan if the roof fan should fail and the auxiliary fan keeps running. This could expose hospital personnel in areas far removed from the sterilizers because their area (or an adjacent one) is served by the exhaust system from the sterilizer room.

#### VENTILATION ALARMS

Workers could be exposed to EtO if a sterilizer goes through an evacuation cycle, a load transfer procedure, or an in-chamber aeration cycle when the exhaust ventilation is not operating properly. The sterilizer should not be operated if the ventilation system is not functioning properly. Various sensors are available which could be installed to set off an alarm if flow decreased appreciably. However, such a system would require periodic maintenance and checking because lint, which is often present in the central service area from folding the linens, can interfere with the proper operation of flow sensors.

#### GENERAL VENTILATION

In this study, the volume of nonrecirculated air exhausted per hour relative to the room volume, usually referred to as "room air changes per hour," was not shown to be as important in controlling routine emissions of EtO as other engineering controls. However, if a large quantity EtO were released, a high rate of ventilation would be helpful in clearing the room, provided that all air is exhausted directly outside the building and not recirculated to any areas of the hospital. Typical ventilation rates found to be adequate are shown in Table 15.



**Table 15. Typical Ventilation Rates Found to be Effective for Access Rooms.**

| <b>Type of Equipment</b>                                 | <b>Exhaust Volume<br/>cfm</b> |
|--|-------------------------------|
| Small (> 10. cu.ft.) electrically heated gas sterilizers | 100                           |
| Large Steam-heated gas sterilizers and steam sterilizers | 250                           |
| Aerators and instrument washer units                     | 175                           |

## WORK PRACTICES

Exposures to emitted EtO may be lessened by limiting the closeness to the sources and/or the duration of the contact. Holding a load close to the breathing zone resulted in an elevated exposure. A 15-minute door-cracked period prior to transferring the load from the sterilizer to the aerator was effective at reducing the quantity of EtO in the chamber which could potentially expose workers.

## EtO ALARMS

Implementing controls for emissions and exposures will reduce the likelihood and severity of exposures; however, the potential for an exposure can never be completely eliminated. The possibility of exposures above recommended limits due to accidents or malfunctions will always exist. Accidents can happen, and may involve the release of large amounts of EtO. Because the odor of EtO cannot be detected at concentrations much less than 700 ppm, workers can be exposed to potentially harmful amounts of EtO without knowing it, and sensors and alarms are needed to warn of elevated EtO concentrations. Relatively inexpensive EtO sensors and alarm systems are available which could alert workers to an emergency situation involving the presence of a high concentration (greater than 20 ppm) of EtO. Other more sophisticated (and more expensive) systems have been developed which could detect elevated concentrations on the order of 1 ppm or less.

## EMERGENCY PROCEDURES

Hospital personnel could be overexposed if a large, uncontrolled release of EtO occurred. Most hospitals surveyed had developed emergency response plans, although only a few had rehearsed the plan to make sure everyone knew what to do.

## ROUTINE MONITORING

NIOSH Method 1607 utilized with personal sampling pumps operated at flow rates of 10 mL/min (for 8 hours) and 50 mL/min (for 5 to 20 minutes) proved adequate for a 0.1 ppm 8-hour TWA and a 5 ppm STEL, respectively. From 0 to 94 percent of the air samples collected for EtO on charcoal tubes (NIOSH Method 1607) in this study were below the limits of detection (LODs) of the method. Limits of detection varied from 0.1 to 1.4 µg per sample, depending on the sample lot, the method of determining the LOD, and the laboratory performing the analysis. Method 1614 was issued in 1987, replacing Method 1607 utilized in this study. This method is a modification of OSHA Method 50. In addition to a larger sample capacity, the new method is more convenient to use, utilizing a single sorbent tube with an integral backup section in place of the two separate, larger tubes used with Method 1607.

## RECOMMENDATIONS

When EtO is used, the control strategy should principally depend on the containment of EtO within sealed containers, equipment, and piping. Where exposures may occur, such as in the unloading of sterilized loads, a combination of local ventilation, good work practices, and personal protective equipment is needed to control exposures. The dilution ventilation system should be designed to reduce the potential for widespread exposures to EtO, and anticipated discharge points should also be designed to avoid additional exposures. Maintenance of equipment and controls and monitoring to assure proper performance and provide timely feedback of control effectiveness are also very important. The implementation of a good respiratory protection program and the labeling and posting of hazards are other components of a complete system of controls. All of these items are discussed in more detail in the following text and have been included in NIOSH's Current Intelligence Bulletin 52.<sup>74</sup>

### EXPOSURE SOURCES AND SPECIFIC CONTROL METHODS

#### Sterilizer Area

##### Exposure Source--

Sterilizer leaks can occur from the failure of gaskets, valves, or other equipment as well as from other sources described in this report. The layout of the sterilizer system can significantly affect the potential for EtO exposure if a leak should occur.

##### Control Methods--

If a sterilizer is supplied by a gas cylinder (Figure 19), the sterilizer, cylinder, and associated piping should be contained in a mechanical access room (also called the equipment room or recess room). Access to the front of the sterilizer should be gained through a separate loading room. The loading room should not be routinely occupied when the sterilizer is operating. A window should allow direct observation of the loading area and control console. Sterilizers using cartridges should also be located in separate, ventilated rooms or in laboratory hoods that are appropriate for controlling EtO exposure.

#### Operation of Sterilizers

##### Supply Cylinders--

Exposure source--Compressed-gas supply cylinders are potentially large sources of EtO exposure. A typical large supply cylinder of the 12:88 gas mixture contains 7,000 g of EtO. The supply line from such a cylinder contains liquid EtO under pressure. If this line is not properly purged before disconnection, the worker may be exposed to EtO from residual liquid or vapor in the supply line.

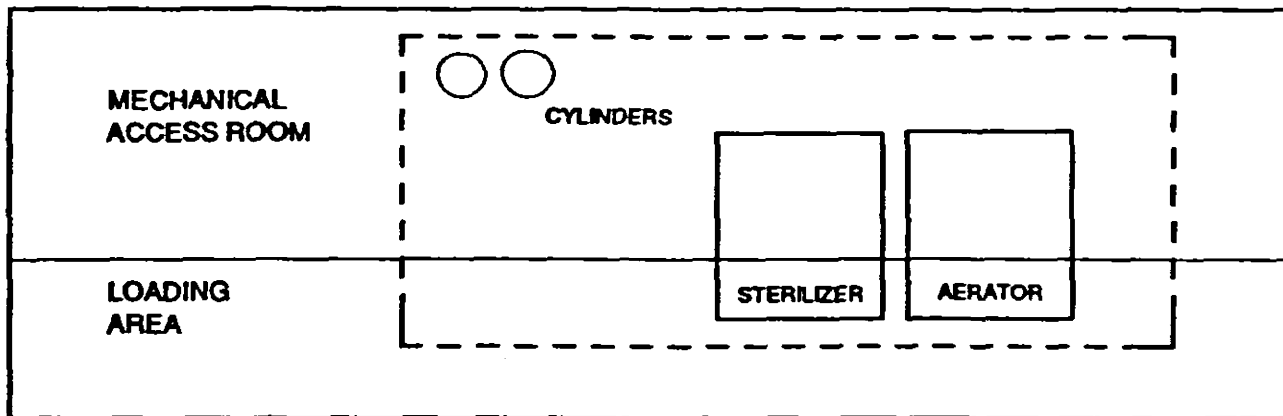

OVERHEAD VIEW OF STERILIZER AREA

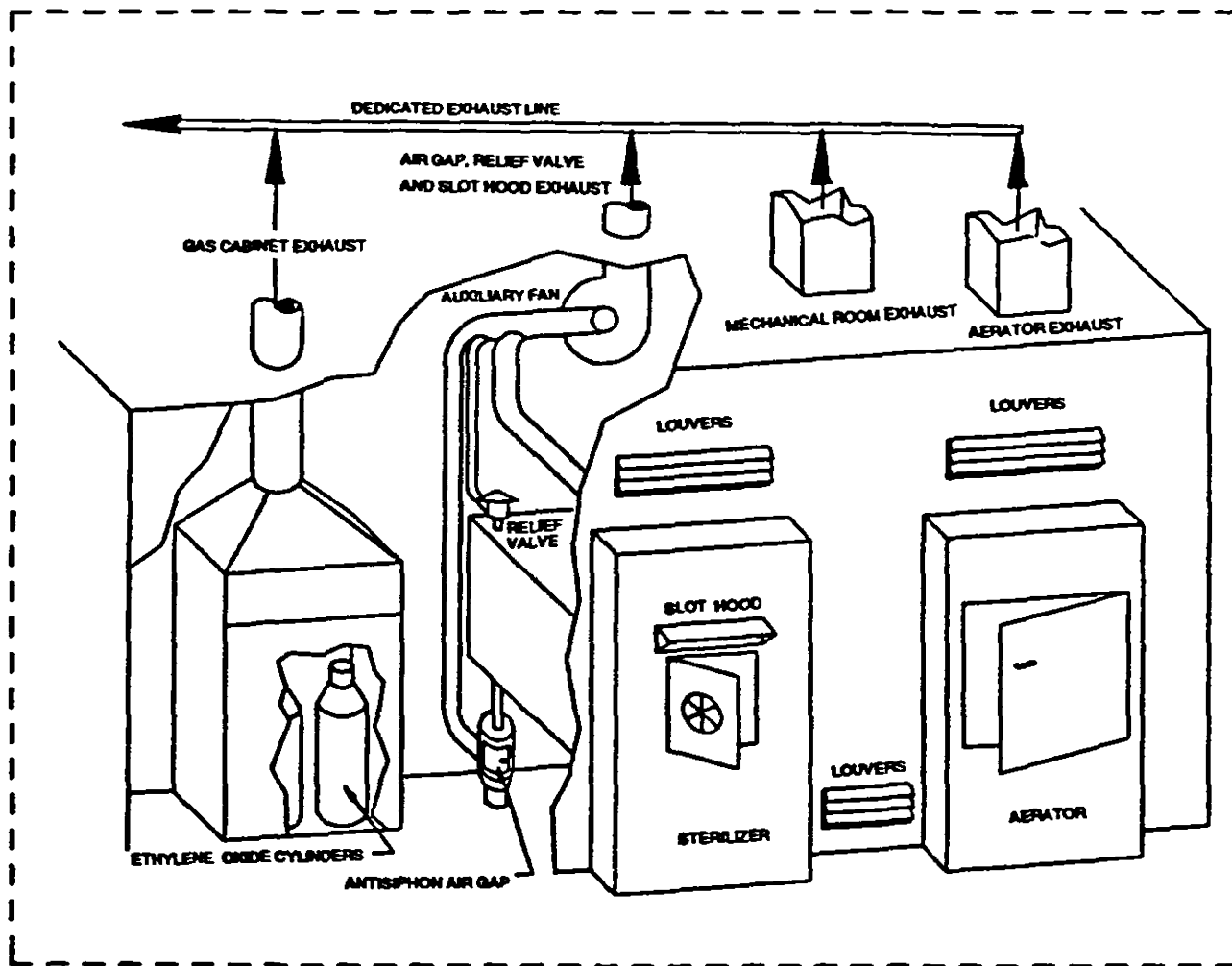

CUT-AWAY VIEW OF STERILIZER AREA

Figure 19. Gas-cylinder-supplied EtO sterilizer with isolated loading area and mechanical access room.

**Control methods--**To control the inhalation hazard, local exhaust ventilation should be provided above the supply cylinders where they are connected to the sterilizer supply line(s), or the supply cylinders should be enclosed in a ventilated cabinet.

To protect workers who must disconnect the supply cylinder, a three-way vent valve should be installed on the supply line where it connects to the cylinder shut-off valve. This three-way valve should direct residual EtO from the supply line to a dedicated exhaust ventilation system or to the ventilated enclosure around the evacuation line and drain air gap.

The EtO supply line from the tank to the sterilizer should also contain a pressure gauge. The supply valve, tank valve, and vent valve should be labeled; these labels should be consistent with the written operating instructions. When changing the supply cylinder or disconnecting any portion of the supply line, workers should wear a full-face shield, protective gloves, and other protective clothing as required by OSHA (29 CFR 1910.1047)<sup>75</sup> to protect any area of the body that may come in contact with liquid EtO. For maximum protection, the gloves should be made of nitrile or butyl rubber.

#### **Newly Sterilized Loads--**

**Exposure sources--**Direct contact with EtO may occur when the operator transfers a load from the sterilizer to the aerator. A typical charge of EtO produces concentrations greater than 200,000 ppm in the sterilizer during the sterilization cycle. Grab samples taken during surveys showed concentrations up to approximately 4,000 ppm in the chamber when the door was first opened.

High EtO concentrations (10 to 100 ppm) can build up around newly sterilized, unaerated loads. Workers may therefore increase their exposures significantly by close contact with such loads for more than a few seconds (unloading requires 1 to 2 minutes).

**Control methods--**For maximum protection, the concentration of EtO in the sterilizer chamber should be as low as possible before the worker opens the door and removes the load. To eliminate or greatly reduce exposure to newly sterilized loads, in-chamber aeration should be used if available. If it is necessary to transfer the load to achieve aeration, workers should run as many post-sterilization EtO-reduction cycles as time allows. To further reduce the chamber concentration of EtO before load transfer, a ventilated exhaust hood should be installed above the sterilizer door, and the door should be opened for 15 or 20 minutes to the latched position or to a distance of 2 inches, whichever is less.

Workers should spend minimal time in the loading area during the entire sterilization cycle and should be kept away from the area during the door-latched phase. Any handling of a newly sterilized load should be done carefully but as quickly as possible to minimize EtO exposure. The operator should maintain an arm's length distance from the load if possible. A cart should be used to transfer the load, and instead of pushing the load (which may force EtO into the breathing zone), the cart should be either pulled or pushed from the side.

## Ventilation

### Dedicated Exhaust System--

Exposure sources--Ventilation is the principal means for controlling EtO emissions. If the primary EtO exhaust system involves ductwork that has inlets in other rooms of the building, EtO could be spread to these areas. Some sterilizers are fitted with an auxiliary fan to exhaust EtO from the primary emission points around the sterilizer and push the exhausted air into the ventilation system. For sterilizers that use an auxiliary fan, EtO may be forced out other inlet grilles in the ventilation system if the main fan does not have sufficient capacity for the additional exhaust flow from the sterilizer fan.

Significant EtO exposures may occur if the ventilation system fails or if its performance deteriorates significantly. Without reliable ventilation system monitors and alarms, the sterilizer operator may be unaware of a malfunction. An accidental release of a large quantity of EtO could contaminate other areas of the facility through the general ventilation system.

Control methods--EtO exhaust should be vented to a dedicated exhaust ventilation system -- that is, a system composed of local exhaust ducts that serve the sterilizer area only (i.e., the area containing the sterilizer, EtO cylinders, aerator, etc.) and route EtO directly to the outside of the building by maintaining a net suction on all of the exhaust ductwork. The exhaust system should be designed so that prevailing winds will not carry the exhaust into populated areas or into the open windows, doors, or air intakes of buildings.<sup>76</sup> If such a system has not yet been installed, and if the system uses one or more auxiliary fans, each grille in the system should be checked under all operating conditions with a smoke tube or other directional-flow indicator to ensure that air is drawn into the exhaust system and not pushed out while auxiliary fans are running.

Flow sensors and alarms should be installed to warn workers of fan failure or degraded performance. The sterilizer should not be operated if the exhaust system is not functioning properly, and the sensor and alarm systems should be checked as recommended by the manufacturer to ensure that they are operating.

### Local Exhaust for Sterilizer Door--

Exposure source--Local exhaust ventilation above the sterilizer door will capture most of the EtO emitted from the partially open sterilizer door if the flow rate is adequate for the location of the exhaust hood. However, when the sterilizer door is first opened, the hot air (100° to 130°F, or 37.8° to 54.4°C) rises and entrains room air. Some EtO may escape if the ventilation hood does not exhaust all of the air rising from the open sterilizer door.

Control method--The local exhaust ventilation hood should be located as close as possible to the top of the sterilizer door. The greater the distance above the door, the larger the hood will need to be and the more air it will need to draw. The hood should be designed to control the EtO under worst-case conditions, which occur when the door is first opened. Any test of the hood's

capacity for containing EtO (e.g., workplace monitoring) should therefore be conducted when the sterilizer door is first opened.

To prevent contamination of other areas of the hospital, the ventilation system serving the EtO sterilizer room should have a dedicated exhaust system.

#### Ventilation Systems for Sterilizer Enclosures and Mechanical Access Rooms--

Exposure sources--Sterilizers that are supplied by compressed-gas cylinders are often recessed into a wall of the sterilizer room. The sterilizer door is usually located in the sterilizer room, but the gas cylinders, drain enclosure, and other potential emission points of EtO are in an adjacent mechanical access room. Workers who must enter the mechanical access room should not be at excess risk of EtO exposure unless engineering controls are absent or operating improperly, or unless an accident occurs. If the ventilation malfunctions, workers are at greatest risk during the purge cycle of the sterilizer, when EtO-laden air is vented from the chamber. If the mechanical access room becomes contaminated, EtO may also escape into work areas through any vents or openings in the walls.

All sterilizers should be located in one mechanical access room with the loading area in an adjacent room. However, the NIOSH survey indicated that some sterilizers were not recessed but were free-standing and enclosed in a cabinet. EtO leaks inside these cabinets (which are not usually ventilated) can also lead to worker exposure.

Control methods--Exhaust ventilation should be such that the net flow of air is from the mechanical access room to the loading room, with a net flow of air into both rooms. In the mechanical access room, air should enter all openings in the upper portion of the enclosure with a face velocity of at least 50 to 100 feet/minute. This velocity should be measured when all equipment in the enclosure is at operating temperature. Also, the ventilation should be sufficient to keep the temperature below 100°F in the area where the EtO cylinders are located. To take advantage of the fact that heated air from the equipment will rise, the room exhaust should be located near the ceiling and the EtO supply should be located near the floor.

To alert workers that a purge cycle is in progress, a warning light should be placed at each entrance to the mechanical access room, and a flashing or revolving light should be placed inside the room. Workers should not enter the mechanical access room during the purge cycle without the appropriate respiratory protection. If a sterilizer is enclosed in a cabinet, the cabinet should be vented to a dedicated exhaust system.

#### Waste Discharges

##### Discharges From Buildings--

Exposure source--When EtO is discharged from buildings, high concentrations can be carried for some distance on prevailing winds. Such EtO emissions can directly expose people downwind of the discharge, or they can enter the intakes of building heating, ventilation, and air conditioning systems.<sup>77</sup>

**Control method**--The exhaust ventilation discharge should be designed so that prevailing winds will not carry EtO into populated areas, open windows, doors, or air intakes for the heating, ventilating, or air conditioning systems of any buildings. The ASHRAE Handbook<sup>76</sup> contains detailed data on the design of ventilation systems. Any environmental release of EtO must comply with Federal, State, and local regulations.

#### **Vacuum Pump and Sewer Drain Discharges--**

**Exposure sources**--During the evacuation phase for sterilizers that use compressed-gas cylinders, 90% to 99% of the EtO in the chamber is discharged into a drain through the water-sealed vacuum pump. Even if the drain air gap between the sterilizer evacuation line and the sewer drain pipe is enclosed and ventilated, significant quantities of EtO may be emitted if the ventilation flow rate is inadequate or if the plumbing from the vacuum pump to the trap in the sewer drain line is not sealed. Another potential source of EtO is leakage from a small drain line connecting the leak-cups of the water-sealed vacuum pump to the floor drain.

**Control methods**--A ventilated enclosure should be placed around the air gap between the sterilizer evacuation line and the drain. Consult the sterilizer manufacturer for the proper exhaust ventilation rate. The vacuum pump discharge line should be installed to prevent water spillage. An air gap must be maintained between the discharge and the drain to avoid siphoning. The air gap should be partially enclosed, baffled, and ventilated. The floor drain junction should be sealed, as should all other connections of the sterilizer evacuation line and the drain line (except the openings into the ventilated enclosure).

#### **Discharge Line From a Single-Dose Cartridge Sterilizer--**

**Exposure source**--Sterilizers that use single-dose cartridges may contain greater than 400,000 ppm EtO in the chamber during sterilization, depending on the quantity of EtO used and the volume of the chamber. During the evacuation phase, more than 55% of the EtO in the chamber will pass through the discharge line. Because this line is pressurized from the venturi vacuum pump to the discharge point, EtO could be forced out if there were any openings in the line.

**Control methods**--As prescribed in the written maintenance procedures, periodic checks should be made to ensure that there are no leaks in the discharge line.

#### **Discharges From Sterilizer Pressure-Relief Valve--**

**Exposure source**--Pressurized sterilizers are fitted with pressure-relief valves. If this valve opens during the sterilization dwell period, EtO is emitted from its discharge point. Also, as air flows into the sterilizer from a vent line at the end of the vacuum purge, the line can become a leak point during the pressurization cycle if failure occurs.

**Control methods**--The pressure-relief valve and air vent line should be vented to the dedicated EtO ventilation system. Consult the sterilizer manufacturer



for the proper tubing size and exhaust ventilation rate required to handle any discharge from this valve.

## Accidental Releases

### Exposure Sources--

Accidental releases of EtO may occur from several sources, including cartridges, sterilizer discharge lines, and EtO supply cylinders. Single-dose cartridges usually contain 67, 100, or 134 g of EtO, depending on their size. An 8.8-foot<sup>3</sup> sterilizer uses a mixture of EtO (12% by weight) and dichlorodifluoromethane, and it discharges approximately 150 g of EtO into the drain during each purge cycle. A typical large supply cylinder for the 12:88 gas mixture contains 7,000 g of EtO.

Because the odor of EtO cannot generally be detected below approximately 700 ppm,<sup>78</sup> workers can be exposed to high concentrations of this compound without knowing it. A relatively small quantity of EtO in an average room can create concentrations that are many times the exposure limit. For example, 1 g of EtO can create a concentration of more than 20 ppm in a 10- by 10-foot room with an 8-foot ceiling.

### Control Methods--

To control accidental releases, the sterilizer, gas cylinders, and associated piping should be contained in a mechanical access room. All exhaust from this room should be routed to a dedicated exhaust ventilation system, which is described in the following section. Access to the front of the sterilizer for loading should be gained through a separate, dedicated loading area.

A thorough review of the design and operation procedures using a form of process hazard analysis is useful for anticipating equipment and work practice failures that could lead to accidental releases.<sup>79,80</sup> A hazard and operability study (a form of process hazard analysis) of an EtO sterilizer system is described in Appendix B.

A written emergency response plan should be developed and practiced in anticipation of an accidental release. In the event of a known or suspected large release of EtO, the emergency response plan should be initiated. The area where the release occurred should be evacuated, and the appropriate personnel and departments should be notified (e.g., safety office, fire department, and maintenance crew). The area should be entered only by persons wearing pressure-demand, self-contained breathing apparatus until the problem is corrected and EtO concentrations return to acceptable levels. Sensors and alarms should be installed to detect and warn of accidental releases of EtO.

## GENERAL CONTROL METHODS

### Maintenance

Maintenance procedures and schedules vary among facilities, and therefore a written maintenance plan should be prepared for each facility that uses EtO sterilization equipment. The procedures should be developed by knowledgeable persons who consider the equipment manufacturers' recommendations, frequency

of use, and other circumstances that might affect the integrity of the equipment. The maintenance plan should also include regular checks of door gaskets, valves, tubing, and piping connections. Maintenance workers should wear the proper personal protective equipment to prevent skin or inhalation exposures, as required in 29 CFR 1910.1047. They should also be aware of potential sources of EtO and procedures for avoiding exposure during maintenance.

### Monitoring

Routine monitoring of the sterilizer and associated equipment as well as the work environment is needed to ensure the continuing effectiveness of engineering control measures, work practices, and equipment maintenance. Workplaces can be monitored for contaminants by using (1) conventional air sampling methods, which determine average concentrations over a period of time, or (2) real-time monitoring devices, which measure actual concentrations at a specific point or interval in time.

#### Conventional Air Sampling--

Sampling methods--NIOSH recommends two air-sampling methods for EtO: Methods 1614<sup>65</sup> and 3702.<sup>66</sup> Method 1614 involves collecting EtO on a hydrogen-bromide-coated charcoal tube and measuring a derivative of EtO (2-bromoethylheptafluorobutyrate) by gas chromatography using an electron-capture detector. The detection limit of this method is 0.0006 ppm EtO per sample, and the working range is 0.05 to 4.6 ppm. This method is applicable to short-term (10-minute) samples.

NIOSH Method 3702 employs a direct-reading technique using a portable gas chromatograph with a photoionization detector. Samples are collected by drawing a known volume of air into a gas-sampling bag. Use of a sampling bag allows sampling times ranging from a few seconds to 8 hours. The working range of this method is 0.001 to 1,000 ppm in relatively noncomplex atmospheres such as those in the sterilizer areas of hospitals.

Sampling strategies--The most reasonable, efficient sampling strategy is to sample the worker with the highest risk of exposure.<sup>68</sup> A maximum-risk worker should be selected and sampled for each operation that poses a risk of EtO exposure. Samples should be obtained during periods of maximum EtO concentration for comparison with ceiling standards. Periods of maximum EtO concentration should be determined by using all available knowledge about the area, workers, and process being sampled.

#### Real-Time Monitoring Devices--

Real-time monitoring devices are an integral part of a control system for EtO. These devices include equipment-function sensors and environmental sensors.

Equipment-function sensors--Equipment-function sensors are used to directly monitor the operation of the sterilizer and exhaust ventilation systems. Examples of these sensors are sail switches that indicate the presence of air flow in the ventilation exhaust ducts, and alarms or warning lights that

indicate the sterilizer is in a purge cycle. Sensors should be connected to an audible alarm and a warning light to alert the operator to an equipment malfunction, or they may be designed to prevent sterilizer operation without the presence of exhaust ventilation.

**Environmental sensors**--Environmental sensors are gas sensors that monitor the atmosphere for the presence of EtO. These devices range from simple, low-cost, organic vapor sensors to complex gas chromatograph systems. Both the sterilizer room and the mechanical access room should be monitored and equipped with an alarm to warn workers of high EtO concentrations.

Monitors do not need to be specific for EtO; for example, an organic vapor detector would be suitable. Gas chromatographic equipment may also be used to monitor EtO concentrations in the work environment. Frequent manual calibrations are required on systems without self-calibration. To avoid confusion, cylinders containing EtO should be stored apart from cylinders containing other gases. The sampling or detection points should be located approximately at breathing zone height, near the EtO cylinders, near the sterilizer body, and in the loading zone. Sampling lines should contain a rotameter or other flow indicator and should be inspected for damage routinely. Monitors should be tested at intervals recommended by the manufacturer.

### **Respiratory Protection**

Respirators are the least preferred method for controlling worker exposure to EtO. They should not be used as the only means of preventing or minimizing exposure during routine operations, but they may be used in the following circumstances; when engineering and work practices are not technically feasible, when engineering controls are in the process of being installed, when emergencies occur, or when certain maintenance operations are being performed (including those requiring confined-space entry).

A respiratory protection program should include an evaluation of the worker's ability to perform the work while wearing a respirator, regular training of personnel, periodic environmental monitoring, and respirator fit testing, maintenance, inspection, and cleaning. Respirators should be selected by a knowledgeable person who is in charge of the program. The program must be evaluated regularly, and at a minimum, it must comply with the requirements of the OSHA respiratory protection standard (29 CFR 1910.134).<sup>75</sup>

Workers should use only respirators that have been certified by NIOSH and the Mine Safety and Health Administration (MSHA). Table 16 lists the minimum respiratory equipment required to meet the NIOSH REL under given conditions. For additional information on the selection and use of respirators, consult the NIOSH Respirator Decision Logic<sup>81</sup> and the NIOSH Guide to Industrial Respiratory Protection.<sup>82</sup>

### **Labeling and Posting of Hazards**

Workers must be informed of exposure hazards, potential adverse health effects, and methods for protecting themselves from exposure to EtO. This

**Table 16. NIOSH recommended respiratory protection for EtO**

| Condition  | Minimum respiratory protection*,#  |
|--|--|
| Airborne concentration of <0.1 ppm   | No respirator required   |
| Airborne concentration of 0.1 to 5 ppm   | <p>Any air-purifying, full-facepiece canister respirator that provides protection against EtO and is equipped with an effective end-of-service-life indicator (ESLI), or</p> <p>Any self-contained breathing apparatus (SCBA) equipped with a full facepiece, or</p> <p>Any supplied-air respirator (SAR) equipped with a full facepiece</p> |
| Airborne concentration $\geq$ 5 ppm, or planned or emergency entry into unknown environments | <p>Any SCBA equipped with a full facepiece and operated in a pressure-demand or other positive-pressure mode, or</p> <p>Any SAR equipped with a full facepiece and operated in a pressure-demand or other positive-pressure mode in combination with an auxiliary SCBA operated in a pressure-demand or other positive-pressure mode</p>     |
| Firefighting   | Any SCBA equipped with a full facepiece and operated in a pressure-demand or other positive-pressure mode  |
| Escape only  | <p>Any air-purifying, full-facepiece canister respirator that provides protection against EtO and is equipped with an effective ESLI, or</p> <p>Any appropriate escape-type SCBA</p>   |

\* Only NIOSH/MSHA-approved equipment should be used.

# The respiratory protection listed for any given condition is the minimum required to meet the NIOSH REL of 5 ppm (9 mg/m<sup>3</sup>) for no more than 10 minutes/day or <0.1 ppm (0.18 mg/m<sup>3</sup>) as an 8-hour TWA.

information must be communicated in accordance with OSHA regulations as stipulated in 29 CFR 1910.1047 (Ethylene Oxide)<sup>75</sup> and in 29 CFR 1910.1200 (Hazard Communication)<sup>75</sup>. In addition to the signs and labels required under these regulations, NIOSH recommends that signs outlining good work practices be posted (1) in front of sterilizers, (2) above EtO supply cylinders, and (3) at the entrance to mechanical access rooms.

#### REFERENCES

1. Hine, C.; Rowe, V. K.; White, E. R.; Darmer, Jr., K. I.; and Youngblood, G. T. Epoxy Compounds. *Patty's Industrial Hygiene and Toxicology*. 3d ed. Vol. 2A Toxicology. New York: John Wiley and Sons; 1981:2166-2186.
2. National Institute for Occupational Safety and Health. Current Intelligence Bulletin 35--Ethylene Oxide (EtO). Cincinnati, Ohio: National Institute for Occupational Safety and Health, 1981. (DHHS (NIOSH) publication no. 81-130).
3. Landrigan, P. J.; Meinhardt, T. J.; Gordon, J.; Lipscomb, J. A.; Burg, J. R.; Mazzuckelli, L. F.; Lewis, T. R.; Lemen, R. A. Ethylene Oxide: An Overview of Toxicologic and Epidemiologic Research. *American Journal of Industrial Medicine*. 1984; 6:103-115.
4. Glaser, Z. R. Special Occupational Hazard Review with Control Recommendations for the Use of Ethylene Oxide as a Sterilant in Medical Facilities. U.S. Department of Health, Education, and Welfare, National Institute for Occupational Safety and Health, Pub. No. 77-200; 1977.
5. Kirk-Othmer Encyclopedia of Chemical Technology. 3rd ed. vol. 9. New York: John Wiley and Sons; 1978:456
6. Occupational Safety and Health Administration. Occupational Exposure to Ethylene Oxide: Final Rule. 29 CFR Part 1910, June 22, 1984.
7. U.S. Department of Labor, Occupational Safety and Health Administration, Federal Register: 48-17284; April 21, 1983.
8. Phillips, C. R. Gaseous Sterilization. Disinfection, Sterilization, and Preservation. 2d ed. Philadelphia: Lea and Febiger; 1977:592-610.
9. Perkins, J. J. Sterilization of Medical and Surgical Supplies with Ethylene Oxide. Principles and Methods of Sterilization in Health Sciences. 2d ed. Springfield, IL: Charles C. Thomas; 1969:501-530.
10. Millar, J. D. Statement of the National Institute for Occupational Safety and Health. Occupational Safety and Health Proposed Rule. Occupational Exposure to Ethylene Oxide. July 20, 1983.
11. Abrahams, R. H. Recent Studies on Workers Exposed to Ethylene Oxide. In Jarkasky, J. F. (ed): "The Safe Use of Ethylene Oxide." Proceedings of the Educational seminar Health Industry Manufacturers Association. Washington, D. C. HIMA Report No. 80-4:27-38 and 211-220.
12. Yager, J. W.; Hines, C. J.; Spear, R. C. Exposure to Ethylene Oxide at Work Increases Sister Chromatid Exchanges in Peripheral Lymphocytes. *Science*. 1983; 219: 1221-1223.
13. Snelling, W. M.; Weil, C. S.; Maronpot, R. R. Final Report on Ethylene Oxide Two-Year Inhalation Study on Rats, Project Report 44-20, Bushy Run Research Center (formerly Carnegie-Mellon Institute of Research), January 28, 1981. Submitted by Union Carbide Corporation to the U.S. Environmental Protection Agency under Section 8(e) of the Toxic Substances Control Act, on behalf of the cosponsors of the study (February 1981).

14. LaBordé, J. B.; Kimmel, C. A. The Teratogenicity of Ethylene Oxide Administered Intravenously to Mice. *Toxicology and Applied Pharmacology*. 1980; 56:16-22.
15. Hemminki, R.; Mutanen, P.; Saloniemi, I.; Niemi, M. L.; Vainio, H. Spontaneous Abortions in Hospital Staff Engaged in Sterilizing Instruments with Chemical Agents. *British Medical Journal*. 1982; 285:1461-1463.
16. Yakubova, Z. N.; Shamova, H. A.; Muftakhova, F. A.; Shilova, L. F. Gynecological Sick Rate of Working Women Occupied in the Production of Ethylene Oxide. *Kazanskii Meditsinskii Zhurnal*. 1976; 57:558-560.
17. Generoso, W. M.; Cain, K. T.; Hughes, L. A.; Sega, G. A.; Braden, P. W.; Gosslee, D. G.; and Shelby, M. D. Ethylene Oxide Dose and Dose-Rate Effects in the Mouse Dominant-Lethal Test. *Environmental Mutagenesis*, 8:1-7, 1986.
18. Lynch, D. W.; Lewis, T. R.; Moorman, W. J.; Burg, J.A.; Groth, D.H.; Khan, A.; Ackerman, L.J.; and Cockrell, B.Y. Carcinogenic and Toxicologic Effects of Inhaled Ethylene Oxide and Propylene Oxide in F344 Rats. *Toxicology and Applied Pharmacology*. 1984; 76:69-84.
19. Dunkelberg, H. Carcinogenicity of Ethylene Oxide and 1,2-Propylene Oxide Upon Intra-gastric Administration to Rats. *British Journal of Cancer*. 1982; 46:924-933.
20. Hogstedt, C.; Malmquist, N.; Wadman, B. Leukemia in Workers Exposed to Ethylene Oxide. *Journal of the American Medical Association*. 1979; 241:1132-1133.
21. Hogstedt, C.; Rohlen, O.; Berndtsson, B. S.; Axelson, O.; Ehrenberg, L. A Cohort Study of Mortality and Cancer Incidence in Ethylene Oxide Production Workers. *British Journal of Industrial Medicine*. 1979; 36:276-280.
22. Hogstedt, C.; Aringer, L.; Gustavsson, A. Epidemiologic Support for Ethylene Oxide as a Cancer-Causing Agent. *Journal of the American Medical Association*. 1986; 255(12):1575-1578.
23. Morgan, R. W.; Claxton, K. W.; Divine, B. J.; Kaplan, S. D.; Harris, V. B. Mortality Among Ethylene Oxide Workers. *Journal of Occupational Medicine*. 1981; 23:767-769.
24. Generoso, W. M.; Cain, K. T.; Krishna, M.; Sheu, C. W.; Gryder, R. M. Heritable Translocation and Dominant-Lethal Mutation Induction with Ethylene Oxide in Mice. *Mutation Research*. 1980; 73:133-142.
25. Lynch, D. W.; Lewis, T. R.; Moorman, W. J.; Sabharwal, R. S.; Burg, J. R. Toxic and Mutagenic Effects of Ethylene Oxide and Propylene Oxide on Spermatogenic Functions in Cynomolgus Monkeys. *Toxicologist*. 3:60-68. 1983.
26. Yager, J. W.; Benz, R. D. Sister Chromatid Exchanges Induced in Rabbit Lymphocytes by Ethylene Oxide after Inhalation Exposure. *Environmental Mutagenesis*. 1982; 4:121-134.
27. Hardin, B.D.; Niemeier, R.W.; Sicov, M.R.; and Hackett, P.L. Reproductive-Toxicologic Assessment of the Epoxides Ethylene Oxide, Propylene Oxide, Butylene Oxide, and Styrene Oxide. *Scandinavian Journal of Work, Environment and Health*. 9(2):94-102. 1983
28. Threshold Limit Values of Airborne Contaminants for 1968: Recommended and Intended Values. American Conference of Governmental Industrial Hygienists. Cincinnati, Ohio. 1968.

29. TLVs: Threshold Limit Values for Chemical Substances and Physical Agents in the Workroom Environment with Intended Changes for 1979. American Conference of Governmental Industrial Hygienists. Cincinnati, Ohio. 1979.
30. Threshold Limit Values for Chemical Substances and Physical Agents in the Workroom Environment with Intended Changes for 1981. American Conference of Governmental Industrial Hygienists. Cincinnati, Ohio. 1981.
31. Threshold Limit Values for Chemical Substances and Physical Agents in the Workroom Environment with Intended Changes for 1982. American Conference of Governmental Industrial Hygienists. Cincinnati, Ohio. 1982.
32. Occupational Safety and Health Administration. Occupational Exposure to Ethylene Oxide Final Rule: Supplemental Statement of Reasons. 29 CFR Part 1910, January 2, 1985.
33. Sun M. Study Estimates Higher Risk from Ethylene Oxide Exposure. Science. 1985; 231:448.
34. Anon. Court upholds EtO standard, orders OSHA to adopt STEL or explain why unnecessary. Occupation Safety and Health Reporter. The Bureau of National Affairs, Inc. 16(9):211-212. July 31, 1987.
35. Preamble to OSHA final rule on occupational exposure to ethylene oxide, Federal Register 53-11414, April 6, 1988.
36. NIOSH, Clark County Hospital, Jeffersonville, Indiana. HETA 85-292-1811, July, 1987.
37. Glaser, Z. R. Hospital Worker Exposure to Ethylene Oxide: Problems, Progress, and Recommendations. In: Jarkasky, J. F., ed. The Safe Use of Ethylene Oxide; Proceedings of the Educational Seminar, June 16 to 17, 1980, Arlington, VA; Report No. 80-4, Health Industry Manufacturers Association, Washington, DC; December 1980:55-74.
38. Corn, R. L. Ethylene Oxide Report. American Society for Hospital Central Service Personnel; May, 1983.
39. Good Hospital Practice: Ethylene Oxide Gas--Ventilation Recommendations and Safe Use. American Association for the Advancement of Medical Instrumentation, Arlington, VA; Revised Edition, 1987.
40. Samuels, T. M. Personnel Exposures to Ethylene Oxide in a Central Service Assembly and Sterilization Area. Hospital Topics 56(3); 1978.
41. Phillips, G. B. Controlling Ethylene Oxide Exposures Through Personnel Procedures. In: Jarkasky, J. F., ed. The Safe Use of Ethylene Oxide; Proceedings of the Educational Seminar, June 16 to 17, 1980, Arlington, VA; Report No. 80-4, Health Industry Manufacturers Association, Washington, DC; December 1980:101-107.
42. Runnels, G. Guidelines to Assist Hospitals in the Use of Ethylene Oxide. Hospitals 52(9); 1978.
43. Halleck, F. E. Ethylene Oxide Sterilization -- Its Safe Use by Sterilizer Design. In: Jarkasky, J. F., ed. Ethylene Oxide Safety Issues; Proceedings of the Educational Seminar, Chicago, IL, October 4-5, 1982; Report No. 82-2, Health Industry Manufacturers Association, Washington, DC, December 1982:187-194.
44. Churinetz, R. W., Hennig, W. S., Hinehline, J. L. Ethylene Oxide Facility Design and Ventilation. In: Jarkasky, J. F., ed. Ethylene Oxide Safety Issues; Proceedings of the Educational Seminar, Chicago, IL, October 4-5, 1982; Report No. 82-2, Health Industry Manufacturers Association, Washington, DC, December 1982:195-204.



45. Nevenheim, A. Tests Measure Ethylene Oxide Risk to Hospital's Central Supply Staff. *Hospitals* 53(6); 1979.
46. Samuels, T. M., Corn, R. L. Modification of Large, Built-in, Ethylene Oxide Sterilizers to Reduce Operator Exposure to EtO. *Hospital Topics* 57(6); 1979.
47. Samuels, T. M. Local Exhaust and Cycle Purges Reduce EtO Release. *Hospitals* 55(3); 1981.
48. Barron, W. R., Gunther, D. A., Durnick, T. J., and Young, J. H. Sterilizer Modifications to Minimize Environmental Ethylene Oxide. Pub. No. DB-3005, American Sterilizer Company, Erie, PA; 1981.
49. Roy, P. A. Engineering Control of Ethylene Oxide Exposures from Gas Sterilization. In: Jarkasky, J. F., ed. *The Safe Use of Ethylene Oxide; Proceedings of the Educational Seminar, June 16 to 17, 1980*, Arlington, VA; Report No. 80-4, Health Industry Manufacturers Association, Washington, DC; December 1980:193-208.
50. Barbi, G. J., Butler, G. J., Christensen, D. E. Reducing Ethylene Oxide Workplace Exposure Through Cycle Modifications in Medical Device Sterilization. Paper presented at the annual meeting of the American Chemical Society, Washington, DC, August 28 - September 2, 1983.
51. Lathan, G. P., Glaser, Z. R. Occupational Exposure to Ethylene Oxide in selected North Carolina Hospitals. Paper presented at the American Industrial Hygiene Conference, Cincinnati, Ohio, June 8, 1982.
52. Ikeda, C. Effective Method to Minimize the Residual EtO Level after Sterilization of Plastic Materials Using Ultrasonic Vibration. *Journal of Biomedical Materials Research* 13(3):509-511; 1979.
53. Hennig, W. S., Churinetz, R. W. Ethylene Oxide Sterilization Facility Design and Layout. In: Jarkasky, J. F., ed. *The Safe Use of Ethylene Oxide; Proceedings of the Educational Seminar, June 16 to 17, 1980*, Arlington, VA; Report No. 80-4, Health Industry Manufacturers Association, Washington, DC; December 1980:161-174.
54. Nusbaum, S. R., Phillips, G. B. Ethylene Oxide Ventilation. In: Jarkasky, J. F., ed. *The Safe Use of Ethylene Oxide; Proceedings of the Educational Seminar, June 16 to 17, 1980*, Arlington, VA; Report No. 80-4, Health Industry Manufacturers Association, Washington, D.C.; December 1980:175-192.
55. Samuels, T. M. Reduce Operator Exposure and Environmental Levels of Ethylene Oxide: Utilization of a Unique Local Exhaust on a Small EtO Sterilizer. *Hospital Topics* 57(5); 1979.
56. Korpella, D. B., McJilton, C. E., Hawkinson, T. E. Ethylene Oxide Dispersion from Gas Sterilizers. *American Industrial Hygiene Association Journal* 44(8):589-591; August 1983.
57. Markinson, H. Methods and Equipment for Removal of Ethylene Oxide from Sterilization Systems. In: Jarkasky, J. F., ed. *The Safe Use of Ethylene Oxide; Proceedings of the Educational Seminar, June 16 to 17, 1980*, Arlington, VA; Report No. 80-4, Health Industry Manufacturers Association, Washington, DC; December 1980:131-138.
58. Subcommittee Z79 of the American Association for the Advancement of Medical Instrumentation. REPORTS: Ethylene Oxide Sterilization -- A Guide for Hospital Personnel. *Respiratory Care* 22(1); 1977:30.
59. DeRoos, R. L., Banks, R. S., Rainer, D., Anderson, J. L., Michaelson, G. S. Hospital Ventilation Standards and Energy Conservation: A Summary of the Literature with Conclusions and Recommendations, FY78 Final Report.

- Lawrence Berkeley Laboratory, University of California/Berkeley, Contract No. W-7405-ENG-48, U.S. Department of Energy; September 1978.
60. Samuels, T. M. EtO Exposure Can Be Reduced by Air Systems. Hospitals 54(13); 1980.
  61. Gunther, D. A., Barron, W. R., Durnick, T. J., Young, J. H. Sources of Environmental Ethylene Oxide Gas Contamination in a Simulated Sterilization Facility. Pub. No. DB-3004, American Sterilizer Company, Erie, PA; 1981.
  62. Quint, J. Toxicity of ethylene oxide with emphasis on carcinogenic, reproductive and genetic effects. Hazard Evaluation System and Information System; State of California, Department of Health Services/Department of Industrial Relations. 1982.
  63. Mathewson, W. F. Maintenance of Sterilization Equipment. In: Jarkasky, J. F., ed. The Safe Use of Ethylene Oxide; Proceedings of the Educational Seminar, June 16 to 17, 1980, Arlington, VA; Report No. 80-4, Health Industry Manufacturers Association, Washington, DC; December 1980:139-142.
  64. National Institute for Occupational Safety and Health: Ethylene Oxide, Method 1607 - A Supplement to the NIOSH Manual of Analytical Methods, 3rd ed., Cincinnati, OH (May, 1985).
  65. Williamson, G.: Ethylene Oxide, Method 1614 - A Supplement to the NIOSH Manual of Analytical Methods, 3rd ed., Cincinnati, OH (August, 1987).
  66. Burroughs, G.E.: Ethylene Oxide, Method 3702 - A Supplement to the NIOSH Manual of Analytical Methods, 3rd ed., Cincinnati, OH (May, 1986).
  67. Cummins, K. J. OSHA Method No. 50, "Ethylene Oxide," OSHA Analytical Laboratory, Salt Lake City, UT (unpublished, January, 1985).
  68. Leidel, N. A.; Busch, K. A.; Lynch, J. R.: Occupational Exposure Sampling Strategy Manual. DHEW (NIOSH) Publication No. 77-173, January 1977.
  69. National Institute for Occupational Safety and Health. Comments of the National Institute for Occupational Safety and Health on the Occupational Safety and Health Administration Proposed Rule on Occupational Exposure to Ethylene Oxide, 29 CFR Part 1910, Docket No. H-200B, February 22, 1988.
  70. National Institute for Occupational Safety and Health: Personal Protective Equipment for Hazardous Materials Incidents -- A Selection Guide. DHHS(NIOSH) Pub. No. 84-114, Morgantown, WV (1984).
  71. Hemeon, W.C.L.: Plant and Process Ventilation. 2nd ed., Industrial Press, Inc., New York, NY (1963).
  72. Mutchler, J. E.: Principles of Ventilation, in The Industrial Environment -- Its Evaluation and Control. U.S. Government Printing Office, Washington, DC (1973).
  73. Air Pollution Manual, Part 1 ... Evaluation (2nd Ed.). American Industrial Hygiene Association. 1972; pp 218-225.
  74. National Institute for Occupational Safety and Health. Current Intelligence Bulletin 52--Ethylene Oxide Sterilizers in Health Care Facilities. Cincinnati, Ohio: National Institute for Occupational Safety and Health, 1989. (DHHS (NIOSH) publication no. 89-115).
  75. CFR. Code of federal regulations. Washington, DC: U.S. Government Printing Office, Office of the Federal Register.
  76. ASHRAE (1985). ASHRAE handbook: 1985 fundamentals. Atlanta, GA: Society of Heating, Refrigerating and Air-Conditioning Engineers, Inc., pp. 14.1-14.20.

77. Buonicore, A. J. (1984). In-plant programs to reduce ethylene oxide worker exposure levels. *Pharm. Eng.* 4(4):35-41.
78. Clayton, G. D., Clayton, F. E. (eds.) (1978). *Patty's industrial hygiene and toxicology*. 3rd ed. Vol. 2a, Toxicology. New York, NY: Wiley-Interscience, p. 2186.
79. AIChE (1985). *Guidelines for hazard evaluation procedures*. New York, NY: American Institute of Chemical Engineers.
80. World Bank (1988). *Techniques for assessing industrial hazards: a manual*. Washington, DC: The World Bank, World Bank Technical Paper Number 55.
81. NIOSH (1987). *NIOSH respirator decision logic*. Cincinnati, OH: U.S. Department of Health and Human Services, Public Health Service, Centers for Disease Control, National Institute for Occupational Safety and Health, DHHS (NIOSH) Publication No. 87-108.
82. Bollinger, M. J., Schutz, M. H. (1987). *NIOSH guide to industrial respiratory protection*. U.S. Department of Health and Human Services, Public Health Service, Centers for Disease Control, National Institute for Occupational Safety and Health, DHHS (NIOSH) Publication No. 87-116.

Table A-1. Long-term Charcoal Tube Results\*

| HOSP | STER | SITE | DAY | SHIFT | ID | TEST  | NORMAL | MIN | DET | PPM   |
|------|------|------|-----|-------|----|-------|--------|-----|-----|-------|
|      |      |      |     |       |    | LOADS | LOADS  |     |     |       |
| B    | 2    | O    | 1   | d     | .  | 1     | 0      | 409 | Q   | 0.040 |
| B    | 2    | O    | 1   | e     | .  | 0     | 2      | 431 | Q   | 0.030 |
| B    | 2    | O    | 2   | d     | .  | 1     | 0      | 419 | N   | 0.010 |
| B    | 2    | O    | 2   | e     | .  | 0     | 2      | 401 | Q   | 0.020 |
| B    | 2    | O    | 3   | d     | .  | 1     | 0      | 384 | N   | 0.030 |
| B    | 2    | O    | 3   | e     | .  | 0     | 2      | 488 | N   | 0.010 |
| B    | 2    | S    | 1   | d     | .  | 1     | 0      | 325 | N   | 0.020 |
| B    | 2    | S    | 1   | e     | .  | 0     | 2      | 477 | Q   | 0.030 |
| B    | 2    | S    | 2   | d     | .  | 1     | 0      | 410 | N   | 0.020 |
| B    | 2    | S    | 2   | e     | .  | 0     | 2      | 475 | Q   | 0.020 |
| B    | 2    | S    | 3   | d     | .  | 1     | 0      | 484 | Q   | 0.040 |
| B    | 2    | S    | 3   | e     | .  | 0     | 2      | 483 | N   | 0.010 |
| B    | 2    | T    | 1   | d     | .  | 1     | 0      | 432 | N   | 0.010 |
| B    | 2    | T    | 1   | e     | .  | 0     | 2      | 430 | N   | 0.020 |
| B    | 2    | T    | 2   | d     | .  | 1     | 0      | 394 | N   | 0.010 |
| B    | 2    | T    | 2   | e     | .  | 0     | 2      | 443 | N   | 0.020 |
| B    | 2    | T    | 3   | d     | .  | 1     | 0      | 432 | Q   | 0.030 |
| B    | 2    | T    | 3   | e     | .  | 0     | 2      | 464 | N   | 0.010 |
| B    | 2    | W    | 1   | d     | .  | 1     | 0      | 388 | N   | 0.010 |
| B    | 2    | W    | 1   | e     | .  | 0     | 2      | 390 | N   | 0.010 |
| B    | 2    | W    | 2   | d     | .  | 1     | 0      | 395 | N   | 0.030 |
| B    | 2    | W    | 2   | e     | .  | 0     | 2      | 335 | N   | 0.020 |
| B    | 2    | W    | 3   | d     | .  | 1     | 0      | 421 | N   | 0.010 |
| B    | 2    | W    | 3   | e     | .  | 0     | 2      | 431 | N   | 0.010 |
| C    | 3    | O    | 1   | d     | .  | 1     | 0      | 470 | .   | 0.070 |
| C    | 3    | O    | 1   | e     | .  | 1     | 0      | 392 | Q   | 0.010 |
| C    | 3    | O    | 2   | d     | .  | 1     | 0      | 457 | N   | 0.030 |
| C    | 3    | O    | 2   | e     | .  | 0     | 1      | 455 | N   | 0.010 |
| C    | 3    | O    | 3   | d     | .  | 1     | 0      | 448 | N   | 0.070 |
| C    | 3    | O    | 3   | e     | .  | 0     | 1      | 472 | Q   | 0.085 |
| C    | 3    | S    | 1   | d     | .  | 1     | 0      | 492 | .   | 0.070 |
| C    | 3    | S    | 1   | e     | .  | 1     | 0      | 473 | Q   | 0.050 |
| C    | 3    | S    | 2   | d     | .  | 1     | 0      | 491 | N   | 0.010 |
| C    | 3    | S    | 2   | e     | .  | 0     | 1      | 485 | Q   | 0.010 |
| C    | 3    | S    | 3   | d     | .  | 1     | 0      | 485 | N   | 0.060 |
| C    | 3    | S    | 3   | e     | .  | 0     | 1      | 487 | N   | 0.050 |
| C    | 3    | T    | 1   | d     | .  | 1     | 0      | 489 | Q   | 0.060 |
| C    | 3    | T    | 1   | e     | .  | 1     | 0      | 475 | N   | 0.020 |
| C    | 3    | T    | 2   | d     | .  | 1     | 0      | 491 | N   | 0.020 |
| C    | 3    | T    | 2   | e     | .  | 0     | 1      | 486 | N   | 0.050 |
| C    | 3    | T    | 3   | d     | .  | 1     | 0      | 485 | N   | 0.110 |
| C    | 3    | W    | 1   | d     | .  | 1     | 0      | 369 | .   | 0.220 |
| C    | 3    | W    | 1   | e     | .  | 1     | 0      | 260 | .   | 0.000 |
| C    | 3    | W    | 2   | d     | .  | 1     | 0      | 457 | N   | 0.020 |
| C    | 3    | W    | 2   | e     | .  | 0     | 1      | 455 | N   | 0.030 |
| C    | 3    | W    | 3   | d     | .  | 1     | 0      | 290 | N   | 0.180 |

\*Abbreviations found in Table A-7.

Table A-1 (continued). Long-term Charcoal Tube Results\*

| HOSP | STER | SITE | DAY | SHIFT | ID | TEST  | NORMAL | MIN | DET | PPM   |
|------|------|------|-----|-------|----|-------|--------|-----|-----|-------|
|      |      |      |     |       |    | LOADS | LOADS  |     |     |       |
| C    | 3    | W    | 3   | e     | .  | 0     | 1      | 475 | N   | 0.110 |
| D    | 4    | O    | 1   | d     | .  | 0     | 1      | 471 | N   | 0.096 |
| D    | 4    | O    | 1   | e     | .  | 1     | 0      | 463 | Q   | 0.025 |
| D    | 4    | O    | 3   | e     | .  | 1     | 0      | 467 | Q   | 0.020 |
| D    | 4    | S    | 1   | d     | .  | 0     | 1      | 490 | Q   | 0.033 |
| D    | 4    | S    | 1   | e     | .  | 1     | 0      | 459 | Q   | 0.045 |
| D    | 4    | S    | 2   | d     | .  | 0     | 1      | 495 | N   | 0.126 |
| D    | 4    | S    | 2   | e     | .  | 1     | 0      | 464 | Q   | 0.081 |
| D    | 4    | S    | 3   | d     | .  | 0     | 1      | 502 | Q   | 0.022 |
| D    | 4    | S    | 3   | e     | .  | 1     | 0      | 462 | Q   | 0.050 |
| D    | 4    | T    | 1   | d     | .  | 0     | 1      | 483 | N   | 0.079 |
| D    | 4    | T    | 1   | e     | .  | 1     | 0      | 456 | N   | 0.091 |
| D    | 4    | T    | 2   | d     | .  | 0     | 1      | 494 | N   | 0.078 |
| D    | 4    | T    | 2   | e     | .  | 1     | 0      | 468 | N   | 0.093 |
| D    | 4    | T    | 3   | d     | .  | 0     | 1      | 504 | N   | 0.078 |
| D    | 4    | T    | 3   | e     | .  | 1     | 0      | 461 | Q   | 0.047 |
| D    | 4    | W    | 1   | d     | .  | 0     | 1      | 465 | N   | 0.091 |
| D    | 4    | W    | 1   | e     | .  | 1     | 0      | 462 | N   | 0.132 |
| D    | 4    | W    | 2   | d     | .  | 0     | 1      | 483 | N   | 0.089 |
| D    | 4    | W    | 2   | e     | .  | 1     | 0      | 469 | Q   | 0.031 |
| D    | 4    | W    | 3   | d     | .  | 0     | 1      | 499 | N   | 0.087 |
| D    | 4    | W    | 3   | e     | .  | 1     | 0      | 461 | N   | 0.135 |
| E    | 5    | O    | 1   | d     | .  | 1     | 0      | 464 | N   | 0.035 |
| E    | 5    | O    | 1   | e     | .  | 0     | 1      | 497 | N   | 0.016 |
| E    | 5    | O    | 2   | d     | .  | 1     | 0      | 473 | N   | 0.036 |
| E    | 5    | O    | 2   | e     | .  | 0     | 1      | 489 | N   | 0.027 |
| E    | 5    | O    | 3   | d     | .  | 1     | 0      | 492 | .   | 0.044 |
| E    | 5    | O    | 3   | e     | .  | 0     | 1      | 469 | N   | 0.019 |
| E    | 5    | S    | 1   | d     | .  | 1     | 0      | 489 | N   | 0.019 |
| E    | 5    | S    | 1   | e     | .  | 0     | 1      | 497 | Q   | 0.052 |
| E    | 5    | S    | 2   | d     | .  | 1     | 0      | 495 | .   | 0.112 |
| E    | 5    | S    | 2   | e     | .  | 0     | 1      | 493 | N   | 0.018 |
| E    | 5    | S    | 3   | d     | .  | 1     | 0      | 513 | .   | 0.067 |
| E    | 5    | S    | 3   | e     | .  | 0     | 1      | 477 | N   | 0.055 |
| E    | 5    | T    | 1   | d     | .  | 1     | 0      | 489 | N   | 0.017 |
| E    | 5    | T    | 1   | e     | .  | 0     | 1      | 492 | N   | 0.015 |
| E    | 5    | T    | 2   | d     | .  | 1     | 0      | 495 | N   | 0.015 |
| E    | 5    | T    | 2   | e     | .  | 0     | 1      | 491 | N   | 0.015 |
| E    | 5    | T    | 3   | d     | .  | 1     | 0      | 512 | .   | 0.064 |
| E    | 5    | T    | 3   | e     | .  | 0     | 1      | 482 | N   | 0.026 |
| E    | 5    | W    | 1   | d     | .  | 1     | 0      | 456 | N   | 0.018 |
| E    | 5    | W    | 1   | e     | .  | 0     | 1      | 349 | N   | 0.020 |
| E    | 5    | W    | 2   | d     | .  | 1     | 0      | 467 | N   | 0.018 |
| E    | 5    | W    | 2   | e     | .  | 0     | 1      | 482 | N   | 0.014 |
| E    | 5    | W    | 3   | d     | .  | 1     | 0      | 477 | N   | 0.026 |
| E    | 5    | W    | 3   | e     | .  | 0     | 1      | 480 | N   | 0.025 |
| F    | 7    | O    | 1   | d     | .  | 1     | 0      | 486 | .   | 0.040 |

\*Abbreviations found in Table A-7.

Table A-1 (continued). Long-term Charcoal Tube Results\*

| HOSP | STER | SITE | DAY | SHIFT | ID | TEST  | NORMAL | MIN | DET | PPM   |
|------|------|------|-----|-------|----|-------|--------|-----|-----|-------|
|      |      |      |     |       |    | LOADS | LOADS  |     |     |       |
| F    | 7    | O    | 1   | e     | .  | 0     | 1      | 462 | .   | 0.030 |
| F    | 7    | O    | 2   | d     | .  | 1     | 0      | 496 | .   | 0.010 |
| F    | 7    | O    | 2   | e     | .  | 0     | 1      | 475 | .   | 0.020 |
| F    | 7    | O    | 3   | d     | .  | 1     | 0      | 482 | .   | 0.010 |
| F    | 7    | S    | 2   | e     | .  | 0     | 1      | 476 | .   | 0.150 |
| F    | 7    | S    | 3   | d     | .  | 1     | 0      | 496 | .   | 0.090 |
| F    | 7    | S    | 3   | e     | .  | 0     | 1      | 488 | .   | 0.150 |
| F    | 7    | T    | 1   | d     | .  | 1     | 0      | 489 | .   | 0.020 |
| F    | 7    | T    | 1   | e     | .  | 0     | 1      | 485 | .   | 0.010 |
| F    | 7    | T    | 2   | d     | .  | 1     | 0      | 496 | .   | 0.010 |
| F    | 7    | T    | 2   | e     | .  | 0     | 1      | 476 | .   | 0.010 |
| F    | 7    | T    | 3   | d     | .  | 1     | 0      | 491 | .   | 0.010 |
| F    | 7    | T    | 3   | e     | .  | 0     | 1      | 496 | .   | 0.010 |
| F    | 7    | W    | 1   | d     | .  | 1     | 0      | 485 | .   | 0.030 |
| F    | 7    | W    | 1   | e     | .  | 0     | 1      | 475 | .   | 0.010 |
| F    | 7    | W    | 2   | d     | .  | 1     | 0      | 497 | .   | 0.010 |
| F    | 7    | W    | 2   | e     | .  | 0     | 1      | 478 | N   | 0.010 |
| F    | 7    | W    | 3   | d     | .  | 1     | 0      | 488 | .   | 0.010 |
| F    | 7    | W    | 3   | e     | .  | 0     | 1      | 476 | .   | 0.010 |
| F    | 8    | O    | 1   | d     | .  | 1     | 0      | 486 | .   | 0.040 |
| F    | 8    | O    | 1   | e     | .  | 0     | 1      | 462 | .   | 0.030 |
| F    | 8    | O    | 2   | d     | .  | 1     | 0      | 496 | .   | 0.010 |
| F    | 8    | O    | 2   | e     | .  | 0     | 1      | 475 | .   | 0.020 |
| F    | 8    | O    | 3   | d     | .  | 1     | 0      | 482 | .   | 0.010 |
| F    | 8    | O    | 3   | e     | .  | 0     | 1      | 499 | .   | 0.040 |
| F    | 8    | S    | 1   | d     | .  | 1     | 0      | 481 | .   | 0.096 |
| F    | 8    | S    | 1   | e     | .  | 0     | 1      | 498 | .   | 0.080 |
| F    | 8    | S    | 2   | d     | .  | 1     | 0      | 501 | .   | 0.070 |
| F    | 8    | S    | 2   | e     | .  | 0     | 1      | 476 | .   | 0.100 |
| F    | 8    | S    | 3   | d     | .  | 1     | 0      | 499 | .   | 0.100 |
| F    | 8    | S    | 3   | e     | .  | 0     | 1      | 487 | .   | 0.115 |
| G    | 9    | O    | 1   | d     | .  | 1     | 1      | 444 | .   | 0.050 |
| G    | 9    | O    | 1   | e     | .  | 0     | 1      | 482 | .   | 0.040 |
| G    | 9    | O    | 2   | d     | .  | 0     | 1      | 424 | .   | 0.030 |
| G    | 9    | O    | 2   | e     | .  | 1     | 1      | 494 | .   | 0.040 |
| G    | 9    | O    | 3   | d     | .  | 0     | 1      | 419 | .   | 0.040 |
| G    | 9    | O    | 3   | e     | .  | 1     | 1      | 494 | .   | 0.040 |
| G    | 9    | S    | 1   | d     | .  | 1     | 1      | 448 | .   | 0.060 |
| G    | 9    | S    | 2   | e     | .  | 1     | 1      | 493 | .   | 0.050 |
| G    | 9    | S    | 2   | d     | .  | 0     | 1      | 434 | .   | 0.030 |
| G    | 9    | S    | 3   | e     | .  | 1     | 1      | 491 | .   | 0.050 |
| G    | 9    | S    | 3   | d     | .  | 0     | 1      | 430 | .   | 0.070 |
| G    | 9    | S    | 1   | e     | .  | 0     | 1      | 478 | .   | 0.030 |
| G    | 9    | T    | 1   | d     | .  | 1     | 1      | 451 | .   | 0.020 |
| G    | 9    | T    | 1   | e     | .  | 0     | 1      | 477 | .   | 0.008 |
| G    | 9    | T    | 2   | d     | .  | 0     | 1      | 434 | .   | 0.006 |
| G    | 9    | T    | 2   | e     | .  | 1     | 1      | 493 | .   | 0.020 |

\*Abbreviations found in Table A-7.

Table A-1 (continued). Long-term Charcoal Tube Results\*

| HOSP | STER | SITE | DAY | ID | TEST  |              | MIN | DET | PPM   |
|------|------|------|-----|----|-------|--------------|-----|-----|-------|
|      |      |      |     |    | LOADS | NORMAL LOADS |     |     |       |
| G    | 9    | T    | 3   | .  | 0     | 1            | 429 | .   | 0.030 |
| G    | 9    | T    | 3   | .  | 1     | 1            | 493 | .   | 0.020 |
| G    | 9    | W    | 1   | .  | 1     | 1            | 436 | .   | 0.050 |
| G    | 9    | W    | 3   | .  | 0     | 1            | 424 | .   | 0.020 |
| G    | 9    | W    | 3   | .  | 1     | 1            | 493 | .   | 0.020 |
| H    | 10   | O    | 1   | .  | 0     | 3            | 500 | .   | 0.120 |
| H    | 10   | O    | 2   | .  | 2     | 0            | 462 | .   | 0.060 |
| H    | 10   | O    | 3   | .  | 0     | 2            | 474 | .   | 0.070 |
| H    | 10   | S    | 1   | .  | 0     | 2            | 529 | .   | 0.300 |
| H    | 10   | S    | 2   | .  | 1     | 0            | 502 | .   | 0.380 |
| H    | 10   | S    | 3   | .  | 0     | 0            | 493 | .   | 0.340 |
| H    | 10   | T    | 1   | .  | 0     | 3            | 522 | .   | 0.040 |
| H    | 10   | T    | 2   | .  | 2     | 0            | 495 | .   | 0.040 |
| H    | 10   | T    | 3   | .  | 0     | 2            | 493 | Q   | 0.050 |
| H    | 10   | W    | 1   | .  | 0     | 3            | 516 | Q   | 0.010 |
| H    | 10   | W    | 2   | .  | 2     | 0            | 483 | N   | 0.010 |
| H    | 10   | W    | 3   | .  | 0     | 2            | 476 | N   | 0.030 |
| H    | 11   | O    | 1   | .  | 0     | 3            | 500 | .   | 0.120 |
| H    | 11   | O    | 2   | .  | 2     | 0            | 462 | .   | 0.060 |
| H    | 11   | O    | 3   | .  | 0     | 2            | 474 | .   | 0.070 |
| H    | 11   | S    | 1   | .  | 0     | 1            | 531 | .   | 0.250 |
| H    | 11   | S    | 2   | .  | 1     | 0            | 502 | .   | 0.570 |
| H    | 11   | S    | 3   | .  | 0     | 2            | 493 | .   | 0.620 |
| I    | 6    | O    | 1   | .  | 1     | 0            | 460 | .   | 0.270 |
| I    | 6    | O    | 1   | .  | 0     | 1            | 458 | .   | 0.230 |
| I    | 6    | O    | 2   | .  | 1     | 0            | 427 | .   | 0.280 |
| I    | 6    | O    | 2   | .  | 0     | 1            | 465 | .   | 0.210 |
| I    | 6    | O    | 3   | .  | 1     | 0            | 450 | .   | 0.210 |
| I    | 6    | O    | 3   | .  | 0     | 1            | 467 | .   | 0.000 |
| I    | 6    | S    | 1   | .  | 1     | 0            | 459 | .   | 0.410 |
| I    | 6    | S    | 1   | .  | 0     | 1            | 460 | .   | 0.400 |
| I    | 6    | S    | 2   | .  | 1     | 0            | 430 | .   | 0.420 |
| I    | 6    | S    | 2   | .  | 0     | 1            | 472 | .   | 0.360 |
| I    | 6    | S    | 3   | .  | 1     | 0            | 476 | .   | 0.590 |
| I    | 6    | S    | 3   | .  | 0     | 1            | 473 | .   | 0.890 |
| I    | 6    | T    | 1   | .  | 1     | 0            | 454 | .   | 0.220 |
| I    | 6    | T    | 1   | .  | 0     | 1            | 460 | .   | 0.260 |
| I    | 6    | T    | 2   | .  | 1     | 0            | 430 | .   | 0.250 |
| I    | 6    | T    | 2   | .  | 0     | 1            | 475 | .   | 0.290 |
| I    | 6    | T    | 3   | .  | 1     | 0            | 475 | .   | 0.310 |
| I    | 6    | T    | 3   | .  | 0     | 1            | 474 | .   | 0.450 |
| I    | 6    | W    | 1   | .  | 1     | 0            | 458 | .   | 0.360 |
| I    | 6    | W    | 1   | .  | 0     | 1            | 461 | .   | 0.280 |
| I    | 6    | W    | 2   | .  | 1     | 0            | 429 | .   | 0.300 |
| I    | 6    | W    | 2   | .  | 0     | 1            | 465 | .   | 0.160 |
| I    | 6    | W    | 3   | .  | 1     | 0            | 482 | .   | 0.400 |
| I    | 6    | W    | 3   | .  | 0     | 1            | 278 | .   | 0.730 |

\*Abbreviations found in Table A-7.

Table A-2. Short-term Charcoal Tube Results\*

| HOSP | STER | SITE | TEST  |              | MIN  | DET | PPM   |
|------|------|------|-------|--------------|------|-----|-------|
|      |      |      | LOADS | NORMAL LOADS |      |     |       |
| B    | 2    | O    | 1     | 0            | 23.1 | N   | 0.052 |
| B    | 2    | O    | 0     | 1            | 19.9 | N   | 0.056 |
| B    | 2    | O    | 0     | 1            | 18.0 | Q   | 0.132 |
| B    | 2    | O    | 1     | 0            | 20.7 | N   | 0.051 |
| B    | 2    | O    | 0     | 1            | 5.3  | N   | 0.199 |
| B    | 2    | O    | 0     | 1            | 17.3 | N   | 0.061 |
| B    | 2    | O    | 1     | 0            | 29.6 | Q   | 0.167 |
| B    | 2    | O    | 0     | 1            | 17.5 | N   | 0.054 |
| B    | 2    | O    | 0     | 1            | 14.5 | Q   | 0.336 |
| B    | 2    | S    | 1     | 0            | 21.6 | Q   | 0.125 |
| B    | 2    | S    | 0     | 1            | 21.7 | N   | 0.055 |
| B    | 2    | S    | 0     | 1            | 13.8 | Q   | 0.463 |
| B    | 2    | S    | 1     | 0            | 20.4 | Q   | 0.076 |
| B    | 2    | S    | 0     | 1            | 0.0  | .   | 0.000 |
| B    | 2    | S    | 0     | 1            | 19.8 | Q   | 0.078 |
| B    | 2    | S    | 1     | 0            | 29.7 | Q   | 0.289 |
| B    | 2    | S    | 0     | 1            | 18.9 | N   | 0.047 |
| B    | 2    | S    | 0     | 1            | 14.0 | Q   | 0.354 |
| C    | 3    | O    | 1     | 0            | 19.0 | N   | 0.199 |
| C    | 3    | O    | 0     | 1            | 12.0 | N   | 0.157 |
| C    | 3    | O    | 1     | 0            | 17.0 | N   | 0.108 |
| C    | 3    | O    | 0     | 1            | 22.0 | N   | 0.172 |
| C    | 3    | O    | 1     | 0            | 32.0 | N   | 0.119 |
| C    | 3    | O    | 0     | 1            | 20.0 | N   | 0.419 |
| C    | 3    | S    | 1     | 0            | 19.0 | Q   | 0.290 |
| C    | 3    | S    | 0     | 1            | 17.0 | Q   | 0.511 |
| C    | 3    | S    | 1     | 0            | 17.0 | N   | 0.208 |
| C    | 3    | S    | 0     | 1            | 27.0 | N   | 0.138 |
| C    | 3    | S    | 1     | 0            | 32.0 | N   | 0.112 |
| C    | 3    | S    | 0     | 1            | 20.0 | Q   | 0.412 |
| D    | 4    | O    | 0     | 1            | 6.0  | N   | 2.960 |
| D    | 4    | O    | 1     | 0            | 14.0 | Q   | 0.610 |
| D    | 4    | O    | 0     | 1            | 15.0 | N   | 1.410 |
| D    | 4    | O    | 1     | 0            | 16.0 | N   | 0.920 |
| D    | 4    | O    | 0     | 1            | 15.0 | N   | 1.330 |
| D    | 4    | O    | 1     | 0            | 15.0 | Q   | 0.390 |
| D    | 4    | S    | 0     | 1            | 15.0 | Q   | 0.600 |
| D    | 4    | S    | 1     | 0            | 14.0 | Q   | 0.440 |
| D    | 4    | S    | 0     | 1            | 15.0 | N   | 1.410 |
| D    | 4    | S    | 1     | 0            | 16.0 | Q   | 1.500 |
| D    | 4    | S    | 0     | 1            | 15.0 | N   | 1.320 |
| D    | 4    | S    | 1     | 0            | 15.0 | Q   | 0.470 |
| E    | 5    | O    | 1     | 0            | 5.2  | Q   | 1.273 |
| E    | 5    | O    | 0     | 1            | 5.9  | N   | 0.460 |
| E    | 5    | O    | 1     | 0            | 4.4  | Q   | 1.796 |
| E    | 5    | O    | 0     | 1            | 3.8  | N   | 0.675 |

\*Abbreviations found in Table A-7.



Table A-2 (continued). Short-term Charcoal Tube Results\*

| HOSP | STER | SITE | TEST  |              | MIN  | DET | PPM   |
|------|------|------|-------|--------------|------|-----|-------|
|      |      |      | LOADS | NORMAL LOADS |      |     |       |
| E    | 5    | O    | 1     | 0            | 4.7  | .   | 1.766 |
| E    | 5    | O    | 0     | 1            | 3.1  | .   | 3.562 |
| E    | 5    | S    | 1     | 0            | 0.0  | .   | 0.000 |
| E    | 5    | S    | 0     | 1            | 5.0  | .   | 1.410 |
| E    | 5    | S    | 1     | 0            | 5.3  | .   | 5.418 |
| E    | 5    | S    | 0     | 1            | 4.4  | .   | 1.970 |
| F    | 8    | O    | 1     | 0            | 19.2 | .   | 0.137 |
| F    | 7    | O    | 1     | 0            | 18.0 | .   | 0.411 |
| F    | 8    | O    | 0     | 1            | 1.0  | N   | 1.371 |
| F    | 7    | O    | 0     | 1            | 1.6  | .   | 5.818 |
| F    | 8    | O    | 1     | 0            | 15.1 | .   | 0.099 |
| F    | 7    | O    | 1     | 0            | 7.4  | N   | 0.244 |
| F    | 8    | O    | 0     | 1            | 15.7 | .   | 0.109 |
| F    | 7    | O    | 0     | 1            | 16.4 | .   | 0.309 |
| F    | 8    | O    | 1     | 0            | 16.7 | .   | 0.073 |
| F    | 7    | O    | 1     | 0            | 16.6 | .   | 0.113 |
| F    | 8    | O    | 0     | 1            | 19.0 | .   | 0.509 |
| F    | 7    | O    | 0     | 1            | 17.5 | .   | 0.489 |
| F    | 8    | S    | 1     | 0            | 18.0 | .   | 0.205 |
| F    | 7    | S    | 1     | 0            | 19.2 | .   | 0.539 |
| F    | 8    | S    | 0     | 1            | 18.9 | .   | 0.302 |
| F    | 7    | S    | 0     | 1            | 15.4 | .   | 0.345 |
| F    | 8    | S    | 1     | 0            | 15.4 | .   | 0.171 |
| F    | 7    | S    | 1     | 0            | 17.6 | .   | 0.309 |
| F    | 8    | S    | 0     | 1            | 16.9 | .   | 0.221 |
| F    | 7    | S    | 0     | 1            | 16.8 | .   | 0.364 |
| F    | 8    | S    | 1     | 0            | 17.6 | .   | 0.151 |
| F    | 7    | S    | 1     | 0            | 18.4 | .   | 0.416 |
| F    | 8    | S    | 0     | 1            | 19.4 | .   | 0.191 |
| F    | 7    | S    | 0     | 1            | 15.9 | .   | 0.305 |
| G    | 9    | O    | 0     | 1            | 1.8  | .   | 1.333 |
| G    | 9    | O    | 1     | 0            | 2.9  | .   | 1.350 |
| G    | 9    | O    | 0     | 1            | 2.4  | .   | 2.723 |
| G    | 9    | O    | 0     | 1            | 2.8  | .   | 1.302 |
| G    | 9    | O    | 0     | 1            | 0.0  | .   | 0.000 |
| G    | 9    | O    | 1     | 0            | 3.9  | .   | 1.611 |
| G    | 9    | O    | 0     | 1            | 3.5  | .   | 2.523 |
| G    | 9    | O    | 0     | 1            | 2.1  | .   | 0.466 |
| G    | 9    | O    | 1     | 0            | 2.1  | .   | 3.498 |
| G    | 9    | S    | 0     | 1            | 1.9  | .   | 1.969 |
| G    | 9    | S    | 1     | 0            | 2.7  | .   | 2.477 |
| G    | 9    | S    | 0     | 1            | 6.5  | .   | 1.576 |
| G    | 9    | S    | 0     | 1            | 3.8  | .   | 1.864 |
| G    | 9    | S    | 0     | 1            | 3.2  | .   | 0.839 |
| G    | 9    | S    | 1     | 0            | 4.0  | .   | 2.252 |
| G    | 9    | S    | 0     | 1            | 3.4  | .   | 3.273 |

\*Abbreviations found in Table A-7.

Table A-2 (continued). Short-term Charcoal Tube Results\*

| HOSP | STER | SITE | TEST  |              | MIN  | DET | PPM   |
|------|------|------|-------|--------------|------|-----|-------|
|      |      |      | LOADS | NORMAL LOADS |      |     |       |
| G    | 9    | S    | 0     | 1            | 2.4  | .   | 1.120 |
| G    | 9    | S    | 1     | 0            | 2.0  | .   | 5.879 |
| H    | 10   | O    | 0     | 1            | 20.0 | .   | 0.539 |
| H    | 10   | O    | 1     | 0            | 20.0 | Q   | 0.249 |
| H    | 11   | O    | 1     | 0            | 21.0 | Q   | 0.148 |
| H    | 11   | O    | 0     | 1            | 23.0 | .   | 0.391 |
| H    | 11   | O    | 0     | 1            | 19.0 | Q   | 0.348 |
| H    | 11   | S    | 0     | 1            | 21.0 | .   | 0.852 |
| H    | 10   | S    | 0     | 1            | 23.0 | .   | 1.628 |
| H    | 10   | S    | 0     | 1            | 20.0 | .   | 5.291 |
| H    | 10   | S    | 1     | 0            | 19.0 | .   | 2.007 |
| H    | 11   | S    | 1     | 0            | 21.0 | .   | 3.223 |
| H    | 11   | S    | 0     | 1            | 23.0 | .   | 7.788 |
| H    | 11   | S    | 0     | 1            | 19.0 | .   | 2.491 |
| I    | 6    | O    | 1     | 0            | 18.0 | .   | 1.502 |
| I    | 6    | O    | 0     | 1            | 17.0 | .   | 1.430 |
| I    | 6    | O    | 1     | 0            | 16.0 | .   | 2.642 |
| I    | 6    | O    | 0     | 1            | 16.0 | .   | 1.723 |
| I    | 6    | O    | 1     | 0            | 16.0 | .   | 0.703 |
| I    | 6    | O    | 0     | 1            | 16.0 | .   | 0.481 |
| I    | 6    | S    | 1     | 0            | 18.0 | .   | 4.559 |
| I    | 6    | S    | 0     | 1            | 27.0 | .   | 3.635 |
| I    | 6    | S    | 1     | 0            | 18.0 | .   | 5.104 |
| I    | 6    | S    | 0     | 1            | 17.0 | .   | 6.267 |
| I    | 6    | S    | 1     | 0            | 16.0 | .   | 4.000 |
| I    | 6    | S    | 0     | 1            | 16.0 | .   | 3.410 |

\*Abbreviations found in Table A-7.

Table A-3. Gas-Bag/GC Results\*

| HOSP | STER | SITE | DAY | SHIFT | ID | TEST  |        | MIN   | DET | PPM   |
|------|------|------|-----|-------|----|-------|--------|-------|-----|-------|
|      |      |      |     |       |    | LOADS | NORMAL |       |     |       |
| A    | 1    | O    | 1   | d     | .  | 0     | 1      | 1.08  | N   | 0.20  |
| A    | 1    | O    | 2   | d     | .  | 0     | 1      | 0.79  | .   | 0.20  |
| A    | 1    | O    | 3   | d     | .  | 0     | 1      | 0.86  | N   | 0.20  |
| A    | 1    | S    | 1   | d     | .  | 0     | 1      | 1.84  | N   | 0.20  |
| A    | 1    | S    | 2   | d     | .  | 0     | 1      | 0.79  | N   | 0.20  |
| A    | 1    | S    | 3   | d     | .  | 0     | 1      | 0.88  | N   | 0.20  |
| C    | 3    | O    | 1   | d     | .  | 1     | 0      | 1.32  | .   | 0.60  |
| C    | 3    | O    | 1   | e     | .  | 1     | 0      | 0.93  | .   | 0.40  |
| C    | 3    | O    | 2   | d     | .  | 1     | 0      | 1.38  | .   | 0.90  |
| C    | 3    | O    | 2   | e     | .  | 0     | 1      | 1.18  | .   | 0.20  |
| C    | 3    | O    | 3   | d     | .  | 1     | 0      | 0.98  | .   | 0.30  |
| C    | 3    | O    | 3   | e     | .  | 0     | 1      | 1.37  | .   | 1.00  |
| C    | 3    | S    | 1   | d     | .  | 1     | 0      | 18.60 | .   | 0.30  |
| C    | 3    | S    | 1   | e     | .  | 1     | 0      | 17.50 | .   | 0.24  |
| C    | 3    | S    | 2   | d     | .  | 1     | 0      | 16.50 | N   | 0.30  |
| C    | 3    | S    | 2   | e     | .  | 0     | 1      | 27.00 | N   | 0.20  |
| C    | 3    | S    | 3   | d     | .  | 1     | 0      | 31.50 | .   | 0.20  |
| C    | 3    | S    | 3   | e     | .  | 0     | 1      | 21.40 | N   | 0.20  |
| D    | 4    | O    | 1   | d     | .  | 0     | 1      | 3.40  | .   | 2.20  |
| D    | 4    | O    | 1   | e     | .  | 1     | 0      | 2.26  | .   | 1.80  |
| D    | 4    | O    | 2   | d     | .  | 0     | 1      | 1.90  | .   | 3.70  |
| D    | 4    | O    | 2   | e     | .  | 1     | 0      | 4.00  | .   | 2.30  |
| D    | 4    | O    | 3   | d     | .  | 0     | 1      | 2.00  | .   | 0.40  |
| D    | 4    | O    | 3   | e     | .  | 1     | 0      | 2.00  | .   | 0.20  |
| D    | 4    | S    | 1   | d     | .  | 0     | 1      | 15.00 | .   | 13.30 |
| D    | 4    | S    | 1   | e     | .  | 1     | 0      | 14.00 | .   | 5.40  |
| D    | 4    | S    | 2   | d     | .  | 0     | 1      | 15.00 | .   | 5.10  |
| D    | 4    | S    | 2   | e     | .  | 1     | 0      | 16.00 | .   | 2.20  |
| D    | 4    | S    | 3   | d     | .  | 0     | 1      | 15.00 | .   | 4.10  |
| D    | 4    | S    | 3   | e     | .  | 1     | 0      | 15.00 | .   | 0.40  |
| E    | 5    | O    | 1   | d     | .  | 1     | 0      | 4.00  | .   | 3.50  |
| E    | 5    | O    | 1   | e     | .  | 0     | 1      | 2.50  | .   | 2.00  |
| E    | 5    | O    | 2   | d     | .  | 1     | 0      | 1.70  | .   | 5.20  |
| E    | 5    | O    | 2   | e     | .  | 0     | 1      | 4.30  | .   | 0.60  |
| E    | 5    | O    | 3   | d     | .  | 1     | 0      | 2.00  | .   | 5.20  |
| E    | 5    | O    | 3   | e     | .  | 0     | 1      | 3.10  | .   | 0.50  |
| E    | 5    | S    | 1   | d     | .  | 1     | 0      | 5.60  | .   | 0.00  |
| E    | 5    | S    | 1   | e     | .  | 0     | 1      | 5.70  | .   | 4.30  |
| E    | 5    | S    | 2   | d     | .  | 1     | 0      | 1.25  | .   | 27.00 |
| E    | 5    | S    | 2   | e     | .  | 0     | 1      | 3.70  | .   | 1.70  |
| E    | 5    | S    | 3   | d     | .  | 1     | 0      | 5.20  | .   | 4.40  |
| E    | 5    | S    | 3   | e     | .  | 0     | 1      | 4.10  | .   | 1.90  |
| F    | 8    | O    | 1   | d     | .  | 1     | 0      | 0.48  | N   | 0.10  |
| F    | 7    | O    | 1   | d     | .  | 1     | 0      | 0.60  | .   | 9.60  |
| F    | 8    | O    | 1   | e     | .  | 0     | 1      | 0.56  | .   | 0.40  |
| F    | 7    | O    | 1   | e     | .  | 0     | 1      | 1.09  | .   | 1.50  |

\*Abbreviations found in Table A-7.

Table A-3 (continued). Gas-Bag/GC Results\*

| HOSP | STER | SITE | DAY | SHIFT | ID | TEST  | NORMAL | MIN   | DET | PPM  |
|------|------|------|-----|-------|----|-------|--------|-------|-----|------|
|      |      |      |     |       |    | LOADS | LOADS  |       |     |      |
| F    | 8    | O    | 2   | d     | .  | 1     | 0      | 0.55  | .   | 0.50 |
| F    | 7    | O    | 2   | d     | .  | 1     | 0      | 1.10  | .   | 0.20 |
| F    | 8    | O    | 2   | e     | .  | 0     | 1      | 0.38  | .   | 0.80 |
| F    | 7    | O    | 2   | e     | .  | 0     | 1      | 1.05  | .   | 1.20 |
| F    | 8    | O    | 3   | d     | .  | 1     | 0      | 0.87  | .   | 0.30 |
| F    | 7    | O    | 3   | d     | .  | 1     | 0      | 0.46  | .   | 0.30 |
| F    | 8    | O    | 3   | e     | .  | 0     | 1      | 0.95  | .   | 5.20 |
| F    | 7    | O    | 3   | e     | .  | 0     | 1      | 1.27  | .   | 0.30 |
| F    | 8    | S    | 1   | d     | .  | 1     | 0      | 17.00 | .   | 0.30 |
| F    | 7    | S    | 1   | d     | .  | 1     | 0      | 19.00 | .   | 0.70 |
| F    | 8    | S    | 1   | e     | .  | 0     | 1      | 18.00 | .   | 0.30 |
| F    | 7    | S    | 1   | e     | .  | 0     | 1      | 15.00 | .   | 0.20 |
| F    | 8    | S    | 2   | d     | .  | 1     | 0      | 16.00 | .   | 0.20 |
| F    | 7    | S    | 2   | d     | .  | 1     | 0      | 15.00 | .   | 0.30 |
| F    | 8    | S    | 2   | e     | .  | 0     | 1      | 18.00 | .   | 0.20 |
| F    | 7    | S    | 2   | e     | .  | 0     | 1      | 16.00 | .   | 0.30 |
| F    | 8    | S    | 3   | d     | .  | 1     | 0      | 18.00 | N   | 0.20 |
| F    | 7    | S    | 3   | d     | .  | 1     | 0      | 18.00 | .   | 0.40 |
| F    | 8    | S    | 3   | e     | .  | 0     | 1      | 18.00 | N   | 0.15 |
| F    | 7    | S    | 3   | e     | .  | 0     | 1      | 15.00 | .   | 0.20 |
| G    | 9    | O    | 1   | d     | 1  | 0     | 1      | 1.69  | .   | 0.20 |
| G    | 9    | O    | 1   | d     | 2  | 1     | 0      | 2.88  | .   | 0.90 |
| G    | 9    | O    | 1   | e     | .  | 0     | 1      | 2.34  | .   | 0.50 |
| G    | 9    | O    | 2   | d     | .  | 0     | 1      | 4.00  | .   | 0.90 |
| G    | 9    | O    | 2   | e     | 1  | 0     | 1      | 2.51  | .   | 0.50 |
| G    | 9    | O    | 2   | e     | 2  | 1     | 0      | 4.05  | .   | 1.20 |
| G    | 9    | O    | 3   | d     | .  | 0     | 1      | 3.12  | .   | 1.00 |
| G    | 9    | O    | 3   | e     | 1  | 0     | 1      | 3.34  | .   | 0.10 |
| G    | 9    | O    | 3   | e     | 2  | 1     | 0      | 2.00  | .   | 2.60 |
| G    | 9    | S    | 1   | d     | 1  | 0     | 1      | 1.88  | .   | 0.10 |
| G    | 9    | S    | 1   | d     | 2  | 1     | 0      | 2.96  | .   | 0.10 |
| G    | 9    | S    | 1   | e     | .  | 0     | 1      | 2.50  | .   | 0.90 |
| G    | 9    | S    | 2   | d     | .  | 0     | 1      | 4.00  | .   | 1.40 |
| G    | 9    | S    | 2   | e     | 1  | 0     | 1      | 2.59  | .   | 0.70 |
| G    | 9    | S    | 2   | e     | 2  | 1     | 0      | 4.33  | .   | 1.70 |
| G    | 9    | S    | 3   | d     | .  | 0     | 1      | 1.98  | .   | 3.80 |
| G    | 9    | S    | 3   | e     | 1  | 0     | 1      | 2.58  | .   | 0.40 |
| G    | 9    | S    | 3   | e     | 2  | 1     | 0      | 2.00  | .   | 2.90 |
| H    | 11   | O    | 1   | d     | 1  | 0     | 1      | 2.15  | .   | 1.30 |
| H    | 10   | O    | 1   | d     | 2  | 0     | 1      | 2.62  | .   | 0.80 |
| H    | 10   | O    | 1   | d     | 3  | 0     | 1      | 1.22  | .   | 5.10 |
| H    | 10   | O    | 2   | d     | 4  | 1     | 0      | 0.92  | .   | 0.58 |
| H    | 11   | O    | 2   | d     | 5  | 1     | 0      | 0.98  | .   | 0.32 |
| H    | 11   | O    | 3   | d     | 6  | 0     | 1      | 1.01  | .   | 0.50 |
| H    | 11   | O    | 3   | d     | 7  | 0     | 1      | 0.95  | .   | 0.78 |
| H    | 11   | S    | 1   | d     | 1  | 0     | 1      | 21.00 | .   | 0.90 |

\*Abbreviations found in Table A-7.

Table A-3 (continued). Gas-Bag/GC Results\*

| HOSP | STER | SITE | DAY | SHIFT | ID | TEST  |                 | MIN   | DET | PPM  |
|------|------|------|-----|-------|----|-------|-----------------|-------|-----|------|
|      |      |      |     |       |    | LOADS | NORMAL<br>LOADS |       |     |      |
| H    | 11   | S    | 3   | d     | 6  | 0     | 1               | 21.00 | .   | 3.60 |
| H    | 11   | S    | 3   | d     | 7  | 0     | 1               | 17.50 | .   | 1.40 |
| I    | 6    | O    | 1   | d     | .  | 1     | 0               | 2.14  | .   | 2.40 |
| I    | 6    | O    | 1   | e     | .  | 0     | 1               | 1.60  | .   | 2.00 |
| I    | 6    | O    | 2   | d     | .  | 1     | 0               | 1.92  | .   | 2.90 |
| I    | 6    | O    | 2   | e     | .  | 0     | 1               | 1.20  | .   | 2.50 |
| I    | 6    | O    | 3   | d     | .  | 1     | 0               | 1.28  | .   | 3.90 |
| I    | 6    | O    | 3   | e     | .  | 0     | 1               | 1.07  | .   | 0.90 |
| I    | 6    | S    | 1   | d     | .  | 1     | 0               | 16.00 | .   | 4.80 |
| I    | 6    | S    | 1   | e     | .  | 0     | 1               | 27.00 | .   | 4.80 |
| I    | 6    | S    | 2   | d     | .  | 1     | 0               | 16.00 | .   | 6.20 |
| I    | 6    | S    | 2   | e     | .  | 0     | 1               | 17.00 | .   | 5.50 |
| I    | 6    | S    | 3   | d     | .  | 1     | 0               | 16.00 | .   | 7.00 |
| I    | 6    | S    | 3   | e     | .  | 0     | 1               | 16.00 | .   | 2.80 |

\*Abbreviations found in Table A-7.

Table A-4. Chamber Concentration Results\*

| HOSP | STER | DAY | SHIFT | ID | DC_PPM | DO_PPM |
|------|------|-----|-------|----|--------|--------|
| A    | 1    | 1   | d     | .  | 0      | 8      |
| A    | 1    | 2   | d     | .  | 0      | 11     |
| A    | 1    | 3   | d     | .  | 0      | 5      |
| C    | 3    | 1   | d     | .  | 650    | 150    |
| C    | 3    | 1   | e     | .  | 675    | 90     |
| C    | 3    | 2   | d     | .  | 290    | 105    |
| C    | 3    | 2   | e     | .  | 550    | 70     |
| C    | 3    | 3   | d     | .  | 550    | 65     |
| C    | 3    | 3   | e     | .  | 620    | 40     |
| D    | 4    | 1   | d     | .  | 0      | 175    |
| D    | 4    | 1   | e     | .  | 0      | 540    |
| D    | 4    | 2   | d     | .  | 0      | 140    |
| D    | 4    | 2   | e     | .  | 0      | 370    |
| D    | 4    | 3   | d     | .  | 0      | 155    |
| D    | 4    | 3   | e     | .  | 0      | 95     |
| E    | 5    | 1   | d     | .  | 0      | 3200   |
| E    | 5    | 1   | e     | .  | 0      | 3200   |
| E    | 5    | 2   | d     | .  | 0      | 4200   |
| E    | 5    | 2   | e     | .  | 0      | 2750   |
| E    | 5    | 3   | d     | .  | 0      | 2800   |
| E    | 5    | 3   | e     | .  | 0      | 1600   |
| F    | 7    | 1   | e     | .  | 1440   | 4      |
| F    | 8    | 1   | e     | .  | 600    | 9      |
| F    | 7    | 2   | d     | .  | 70     | 6      |
| F    | 8    | 2   | d     | .  | 300    | 8      |
| F    | 7    | 2   | e     | .  | 82     | 46     |
| F    | 8    | 2   | e     | .  | 1180   | 26     |
| F    | 7    | 3   | d     | .  | 520    | 22     |
| F    | 8    | 3   | d     | .  | 660    | 4      |
| F    | 7    | 3   | e     | .  | 108    | 45     |
| F    | 8    | 3   | e     | .  | 284    | 72     |
| G    | 9    | 1   | d     | 1  | 0      | 72     |
| G    | 9    | 1   | d     | 2  | 0      | 790    |
| G    | 9    | 1   | e     | .  | 0      | 820    |
| G    | 9    | 2   | d     | .  | 0      | 610    |
| G    | 9    | 2   | e     | 1  | 0      | 410    |
| G    | 9    | 2   | e     | 2  | 0      | 400    |
| G    | 9    | 3   | d     | .  | 0      | 1240   |
| G    | 9    | 3   | e     | 1  | 0      | 320    |
| G    | 9    | 3   | e     | 2  | 0      | 510    |
| H    | 11   | 1   | d     | 1  | 2250   | 55     |
| H    | 10   | 1   | d     | 2  | 3100   | 140    |
| H    | 10   | 1   | d     | 3  | 2250   | 150    |
| H    | 10   | 2   | d     | 4  | 2640   | 132    |
| H    | 11   | 2   | d     | 5  | 3250   | 32     |
| H    | 11   | 3   | d     | 6  | 2900   | 40     |
| H    | 11   | 3   | d     | 7  | 1730   | 89     |
| I    | 6    | 2   | e     | .  | 1700   | 140    |
| I    | 6    | 3   | d     | .  | 2000   | 700    |
| I    | 6    | 3   | e     | .  | 1500   | 25     |

\*Abbreviations found in Table A-7.

Table A-5. Results\* of nonroutine gas bag samples

| Hospital                                       | Description of Sample  | ppm (#)** |
|--|--|-----------|
| A  | Inside sterilizer chamber                                      | 12. (3)   |
|  | Drain/Mechanical Access Room during first part of purge period | 46. (4)   |
|  | Drain elsewhere in building                                    | <0.2 (1)  |
|  | Inside air handler intake plenum                               | 0.22 (3)  |
|  | Personal sample during cylinder change operation               | 0.1 (1)   |
|  | Area sample during cylinder change operation                   | 0.1 (1)   |
| B  | Drain/Mechanical Access Room during first part of purge period | 9.3 (3)   |
|  | In front of sterilizer, not during purge or LT                 | 0.6 (1)   |
|  | Drain/Mechanical Access Room, not during purge                 | 0.22 (2)  |
|  | Drain elsewhere in building                                    | 1. (1)    |
|  | Above load after aeration                                      | 0.7 (1)   |
|  | Area sample during cylinder change operation                   | 100. (1)  |
|  | In front of sterilizer during purge                            | 0.14 (2)  |
|  | Operator's BZ during the load transfer (LT)                    | 1.4 (3)   |
| Area location in front of sterilizer during LT | 2.3 (3)  |           |
| C  | Mechanical Access room during purge, drain <u>not</u> sealed   | 5000. (1) |
|  | Drain/Mechanical Access Room during first part of purge period | 28. (5)   |
|  | Operator arranging loads in aerator                            | 0.3 (1)   |
|  | Inside aerator chamber   | 1.8 (1)   |
|  | Above load after sterilization                                 | 57. (2)   |
|  | Drain elsewhere in building                                    | <0.2 (1)  |
|  | Operator opening biological indicator pack                     | 0.2 (1)   |
| D  | Operator cleaning sterilizer chamber                           | 0.27 (3)  |
|  | Inside aerator chamber   | 0.59 (5)  |
|  | Drain/Mechanical Access Room, not during purge                 | 0.13 (5)  |
|  | Overpressure Relief Valve during sterilization                 | 1.5 (1)   |
|  | Drain/Mechanical Access Room during first part of purge period | 3.3 (5)   |
|  | Inside Sterilizer Chamber                                      | 0.56 (3)  |
|  | Above load after aeration                                      | 0.32 (2)  |
|  | Drain/Mechanical Access Room during last part of purge period  | 2.4 (1)   |
|  |  |           |
| E  | Drain/Mechanical Access Room during first part of purge period | 45. (11)  |
|  | Drain/Mechanical Access Room during last part of purge period  | 2.9 (12)  |
|  | Inside Sterilizer Chamber                                      | 19. (4)   |

(continued)

Table A-5 (continued)

| Hospital | Description of Sample   | ppm (#)** |
|----------|---|-----------|
| F        | Inside Sterilizer Chamber   | 0.3 (1)   |
| G        | Drain/Mechanical Access Room during first part of purge period                | 2.3 (8)   |
|          | Decontamination room during purge   | 0.62 (6)  |
|          | Inside Sterilizer Chamber   | 214. (2)  |
|          | Inside aerator chamber  | 2.1 (1)   |
|          | Drain elsewhere in building   | 0.30 (2)  |
|          | Near the floor in front of the ster' during LT                                | 0.65 (2)  |
|          | Operator inserting load in sterilizer   | 0.55 (1)  |
|          | In front of sterilizer, not during purge or LT                                | 2.7 (1)   |
| H        | Worker performing maintenance   | 3.5 (1)   |
|          | Drain/Mechanical Access Room during first part of purge period                | 0.91 (3)  |
|          | Area outside the sterilizer room approximately 20 minutes after load transfer | 2.2 (1)   |
| I        | In front of sterilizer, not during purge or LT                                | 0.30 (3)  |
|          | Drain/Mechanical Access Room during last part of purge period                 | 4.4 (6)   |
|          | Inside Sterilizer Chamber   | 10. (3)   |
|          | Operator arranging loads in aerator   | 0.5 (1)   |
|          | Inside aerator chamber  | 1.0 (2)   |
|          | Drain/Mechanical Access Room during first part of purge period                | 61. (2)   |
|          | In front of sterilizer during maintenance                                     | 13. (2)   |

\* Geometric mean if more than one sample

\*\* The number of samples is in parentheses



Table A-6. Infrared analyzer results\*

| HOSP | STER | DAY | SHIFT | ID | PPM-MIN | MIN  | AVG PPM |
|------|------|-----|-------|----|---------|------|---------|
| A    | 1    | 1   | d     | .  | 3.4     | 6.4  | 0.5     |
| A    | 1    | 2   | d     | .  | 3.4     | 8.0  | 0.4     |
| A    | 1    | 3   | d     | .  | 6.0     | 11.7 | 0.5     |
| B    | 2    | 1   | d     | .  | 5.4     | 3.8  | 1.4     |
| B    | 2    | 1   | e     | 1  | 5.8     | 3.8  | 1.6     |
| B    | 2    | 1   | e     | 2  | 10.7    | 5.4  | 2.0     |
| B    | 2    | 2   | d     | .  | 3.9     | 2.1  | 1.8     |
| B    | 2    | 2   | e     | .  | 9.2     | 4.3  | 2.2     |
| B    | 2    | 2   | e     | .  | 4.4     | 4.3  | 1.0     |
| B    | 2    | 3   | d     | .  | 15.6    | 4.3  | 3.6     |
| B    | 2    | 3   | e     | .  | 12.2    | 3.8  | 3.2     |
| B    | 2    | 3   | e     | .  | 5.8     | 3.4  | 1.1     |
| C    | 3    | 1   | d     | .  | 6.5     | 8.7  | 0.8     |
| C    | 3    | 1   | e     | .  | 5.5     | 3.8  | 1.4     |
| C    | 3    | 2   | d     | .  | 2.4     | 2.7  | 0.9     |
| C    | 3    | 2   | e     | .  | 0.7     | 1.6  | 0.5     |
| C    | 3    | 3   | d     | .  | 3.1     | 4.9  | 0.6     |
| C    | 3    | 3   | e     | .  | 1.0     | 2.5  | 0.4     |
| D    | 4    | 1   | d     | .  | 4.3     | 3.8  | 1.1     |
| D    | 4    | 1   | e     | .  | 2.3     | 4.4  | 0.5     |
| D    | 4    | 2   | d     | .  | 2.0     | 7.6  | 0.3     |
| D    | 4    | 3   | d     | .  | 2.3     | 0.8  | 0.4     |
| D    | 4    | 3   | e     | .  | 3.4     |      |         |
| E    | 5    | 1   | d     | .  | 23.8    | 9.6  | 2.5     |
| E    | 5    | 1   | e     | .  | 16.7    | 16.2 | 1.5     |
| E    | 5    | 3   | d     | .  | 35.2    | 11.7 | 3.0     |
| G    | 9    | 1   | d     | 1  | 12.4    | 8.6  | 1.4     |
| G    | 9    | 1   | d     | 2  | 8.2     | 10.7 | 0.8     |
| G    | 9    | 2   | d     | .  | 11.3    | 6.4  | 1.8     |
| G    | 9    | 2   | e     | 1  | 5.1     | 8.0  | 0.4     |
| G    | 9    | 2   | e     | 2  | 10.7    | 6.4  | 1.7     |
| G    | 9    | 3   | d     | .  | 16.0    | 5.4  | 3.0     |
| G    | 9    | 3   | e     | 1  | 16.3    | 5.4  | 3.0     |
| G    | 9    | 3   | e     | 2  | 7.1     | 7.0  | 1.0     |
| I    | 6    | 1   | d     | .  | 91.0    | 33.0 | 2.8     |
| I    | 6    | 1   | e     | .  | 84.5    | 43.7 | 2.0     |
| I    | 6    | 2   | d     | .  | 97.0    | 35.0 | 2.8     |
| I    | 6    | 2   | e     | .  | 101.0   | 29.0 | 3.5     |
| I    | 6    | 3   | d     | .  | 60.0    | 27.0 | 2.2     |
| I    | 6    | 3   | e     | .  | 57.0    | 22.0 | 2.6     |

\*Abbreviations found in Table A-7.

**Table A-7. Abbreviations used in Appendix A**

---

|               |  |
|---------------|--|
| <b>HOSP</b>   | - hospital (see Table 2)   |
| <b>STER</b>   | - sterilizer (see Table 2)   |
| <b>SITE</b>   | - location of a sample<br><b>O</b> - on sterilizer operator<br><b>S</b> - in front of sterilizer<br><b>T</b> - on work table in sterilizer area<br><b>W</b> - on a worker, other than operator, in sterilizer area   |
| <b>DAY</b>    | - day of sampling during survey  |
| <b>SHIFT</b>  | - shift sampled<br><b>d</b> - day<br><b>e</b> - evening  |
| <b>ID</b>     | - an additional identifier needed for certain surveys  |
| <b>MIN</b>    | - duration of sample in minutes  |
| <b>DET</b>    | - relation of sample results with respect to analytical detection limits<br><b>.</b> - the reported value is considered "known"<br><b>Q</b> - the reported value is below the limit of quantitation<br><b>N</b> - The tabulated value is computed from the analytical detection limit; the actual value is probably less than this value |
| <b>DC_PPM</b> | - the concentration in the chamber just after the door was first cracked open  |
| <b>DO_PPM</b> | - the concentration in the chamber just before the door was fully opened   |
| <b>BZ</b>     | - breathing zone   |
| <b>LT</b>     | - load transfer  |

---

## APPENDIX B:

### HAZARD AND OPERABILITY STUDY OF AN ETHYLENE OXIDE STERILIZER

#### INTRODUCTION

The main body of the present report summarizes a 1984-86 study by NIOSH researchers on controls for continuous or routine emissions of ethylene oxide from sterilizer installations in hospitals. The goals of this study were to evaluate and document effective engineering controls used by the hospitals that were studied. This study involved conducting a series of walk-through surveys to identify hospitals for further study, and week-long industrial hygiene sampling at six facilities that were thought to represent state-of-the-art control. This approach is effective in evaluating the efficacy of controls currently in use, but is less useful for identifying possible causes of infrequent and potentially catastrophic releases. Unless process or work practice failures were observed during the survey (which is unlikely), they may not have been considered in this type of study.

As a follow-up to the field study, a second study was conducted to evaluate the potential for a catastrophic or nonroutine releases of EtO. A hazard and operability study (HAZOP), a form of process hazard analysis, was conducted on an EtO sterilizer supplied by compressed-gas cylinders. This sterilizer is similar to most of the sterilizers that are currently used in hospitals. The sterilizer installation, equipment, and operational procedures were reviewed and recommendations were developed both specifically for the studied installation and for the generic installation of any EtO sterilizer.

The success of a HAZOP study depends upon the the knowledge and experience of the personnel involved and on the completeness of the information that is available. A team is assembled drawing from all the areas of interest. In the case of the sterilizer HAZOP, the equipment designers, a manufacturers service representative, the hospital engineering supervisor, and the hospital maintenance supervisor provided the technical expertise on the sterilizer equipment, installation, and procedures. In addition, a team leader and recording secretary were provided on a consulting basis (Technica, Inc., Columbus, Ohio). The team leader was responsible for carrying out the HAZOP in a systematic manner.

The HAZOP technique involves studying the operation as a series of separate systems (called nodes). Using the set of guidewords listed in Table B-1, the team leader guides the group through each segment of the operation. Guidewords from the first part of the list relate to deviations in process parameters, such as too much pressure or no flow. For each guideword, the team attempted to identify a cause, or a series of causes. If no cause could be identified, the team moved on to the next guideword. If a cause was found, the team

discussed the consequences and plausibility of the deviation. If there were no significant consequences, the team proceeded to the next item. For items with both a plausible likelihood and a significant consequence, recommendations were formulated to eliminate or reduce the likelihood of the process deviation. In some cases, notes for additional study or later action were made. A similar procedure was used for guidewords from the second part of the list in Table B-1. These guidewords are not related to process deviations, but rather to specific subject areas or conditions of operation.

## PROCESS DESCRIPTION

The process under study is sterilization of hospital equipment using an ethylene oxide sterilizer. The sterilizer consists of a jacketed chamber and associated pumps, pipes, filters, valves, etc.

The actual equipment layout of the sterilizer at the facility of interest is divided into two containment areas: a loading/unloading area, which incorporates the fronts of two aerators and two sterilizer/aerators; and an equipment area, which contains the aerators, piping, ethylene oxide tanks, and the sterilizer/aerators. The sterilizer chambers are fitted with a safety valve which, depending on the machine design, relieves the chamber at 15 psi or 40 psi; and a jacket safety valve (on steam-heated units), as shown in Figure B-1.

The sterilization process begins with a mixture of liquid ethylene oxide and Freon 12 that passes through a steam-heated heat exchanger and is gasified. The gaseous mixture is fed into a preheated chamber, which contains the materials to be sterilized. The materials remain in the gaseous environment for the required amount of time for proper sterilization. Then, the ethylene oxide/Freon mixture is removed from the chamber by a sequence of exhaust and aeration cycles. A final air wash of the chamber is done to complete the process.

The vented gases leave the chamber through a ventilation system where they mix with air to give an acceptable concentration of ethylene oxide before they are exhausted to atmosphere.

Aqueous effluent from the sterilizer passes to a disengaging funnel, so that any dissolved ethylene oxide which outgasses from the water can be directed to the ventilation system before the liquid effluent passes to the drain.

To aid in understanding the equipment layout, the following definitions were developed:

- (i) Equipment Room - Room where ethylene oxide sterilizer, tanks, and piping are located.
- (ii) Loading Room - Contained room in which the sterilizer loading/unloading takes place.

The layout of the sterilizer is shown in Figure B-1. An overall piping and instrumentation diagram is given in Figure B-2.

The EtO sterilizer system that was evaluated in the HAZOP study was divided into the following components, or nodes, for purposes of the HAZOP:

- Layout of the EtO sterilizer facility (Figure B-1)
- Storage, transport, and changing of the EtO/Freon supply cylinder (Table B-2, Figure B-3)
- EtO piping from the cylinders to the sterilizer (Table B-3, Figure B-4)
- Introduction of EtO/Freon into the EtO sterilizer (Table B-4, Figure B-2)
- Operation of the EtO sterilizer (Tables B-5 and B-6, Figure B-2)
- Utilities and process lines to and from the EtO sterilizer (Tables B-7, B-8, and B-9, Figure B-2)
- Reliability of the dilution ventilation system (Table B-11, Figure B-5)
- Reliability of the EtO area monitoring system (Tables B-12 and B-13, Figure B-6)

These nodes are discussed in the remainder of Appendix B.

#### LAYOUT OF THE ETO STERILIZER FACILITY

The design intention is to assure a safe working area, and to minimize the chances of EtO exposures. General recommendations for this are as follows:

- Ethylene oxide equipment should be isolated from other hospital equipment and should be in a separately enclosed area (containment room). Minimum size and layout should be such that staff and maintenance personnel should have adequate room for working, especially for transportation of ethylene oxide tanks. The ethylene oxide sterilizer and equipment should not be installed in or adjacent to patient areas.
- If the machine control panel cannot be seen from outside the loading room, a remote control panel should be used.

#### STORAGE, TRANSPORT, AND CHANGING OF THE ETO/FREON SUPPLY CYLINDERS

The design intent is to safely store, transport, and install the EtO/Freon cylinders. Figure B-3 depicts the recommended piping and valving arrangements for the supply cylinders. General recommendations for installing new cylinders are as follows:

- Supply valve, tank valve, vent valve, and needle valve to vent should be labeled (see Figure B-3). The same labeling system should be used in the written operating procedures.
- Ethylene oxide piping from tank to sterilizer should contain a line to the exhaust ventilation system.

The HAZOP analysis for cylinder storage is given in Table B-2.

#### ETO/FREON PIPING FROM THE CYLINDERS TO THE STERILIZER

The design intent of this system is to transfer liquid EtO/Freon from the storage cylinders to the sterilizer unit. Figure B-4 shows the arrangement to perform this function. The HAZOP analysis for EtO transport is shown in Table B-3.

#### INTRODUCTION OF ETO INTO THE STERILIZER

The design intent of this system is to introduce vaporized EtO/Freon into the sterilizer. This system is a continuation of the EtO/Freon piping in the previous section. The HAZOP analysis is shown in Table B-4, which refers to Figure B-2.

#### OPERATION OF THE ETO STERILIZER

The design intent of the EtO sterilizer is to provide appropriate sterilization of the reusable hospital supplies without allowing the EtO to escape into the workplace in unacceptable amounts. Table B-5 shows a HAZOP analysis for the routine sterilizer operation. Also, the written operating procedures were reviewed in conjunction with this analysis, and safe practices for these procedures are given.

#### UTILITIES AND PROCESS LINES TO AND FROM THE STERILIZER

In addition to EtO, sterilizer operation also involves flows of air, steam, and condensate, as shown in Figure B-2. Consequences of deviation in these flows are considered in this section. Air is used as a vacuum break in between the vacuum cycles that are used to remove the EtO. Table B-7 shows the results of a HAZOP analysis for this air.

Table B-8 shows the results of a HAZOP analysis for the steam supply to the sterilizer. The design intent is to provide humidification and some heating during the sterilization cycle.

Table B-9 shows the results of a HAZOP analysis for the drain line from the sterilizer. The design intent is to depressurize and evacuate the sterilizer. For later machines, an interlock prevents a high discharge rate through the use of a flow restricter. When the chamber pressure is below atmospheric, a bypass valve opens around the restricter.

A HAZOP analysis of the steam supply to the heat exchanger and sterilizer jacket and of the condensate line from the heat exchanger and sterilizer jacket

showed no issues of concern. The cooling water supply and drain also showed no concerns.

The HAZOP of the pressure relief valve on the sterilizer and of the gas temperature recorder/indicator is shown in Table B-10. The design intent of these items is to maintain proper conditions of temperatures and pressure for sterilization.

#### RELIABILITY OF THE DILUTION VENTILATION SYSTEM

The dilution ventilation should be designed in conjunction with the sterilizer equipment. The design intent is to remove EtO that has escaped into the work area and to vent excess heat from the sterilizer. General recommendations are as follows:

- The equipment room ventilation, loading room (room in which the sterilizer loading/unloading takes place), ventilation, and machine exhaust should be routed to a dedicated ventilation system, separate from other systems. It should be sized to maintain a negative pressure in equipment room relative to loading room, and a negative pressure in loading room relative to all other areas, if for example, a tank hose were to rupture; (this corresponds to a 5.4 lb/s release). A recirculation ventilation system is not safe for ethylene oxide areas.
- Final exhaust fan should be outdoors to keep a negative pressure in the indoor ducts.
- The loading room ventilation should maintain a pressure lower than that in surrounding areas not containing ethylene oxide. The equipment room ventilation should maintain a pressure below that of the loading room. It is suggested to have separate containment rooms (one for the equipment room, and a second for the loading/unloading room). Where separate loading and unloading rooms are provided, these should both be maintained at a lower pressure than surrounding areas. Efficient ventilation would require a high level supply inlet because of thermal stratification (exhaust above supply).

Table B-11 gives the HAZOP analysis for the dilution ventilation system.

#### ETO AREA MONITORING SYSTEM

The facility that was evaluated used a fixed-point gas chromatograph which rotated between a series of lines that drew air from various locations in the sterilizer area.

A HAZOP analysis was done on the transport lines for potentially EtO-laden air from the work areas to the GC. This is shown in Table B-12.

A HAZOP analysis was also done on the line that conducts inert carrier gas from the carrier gas tank to the GC column (Figure B-5). This is shown in Table B-13.



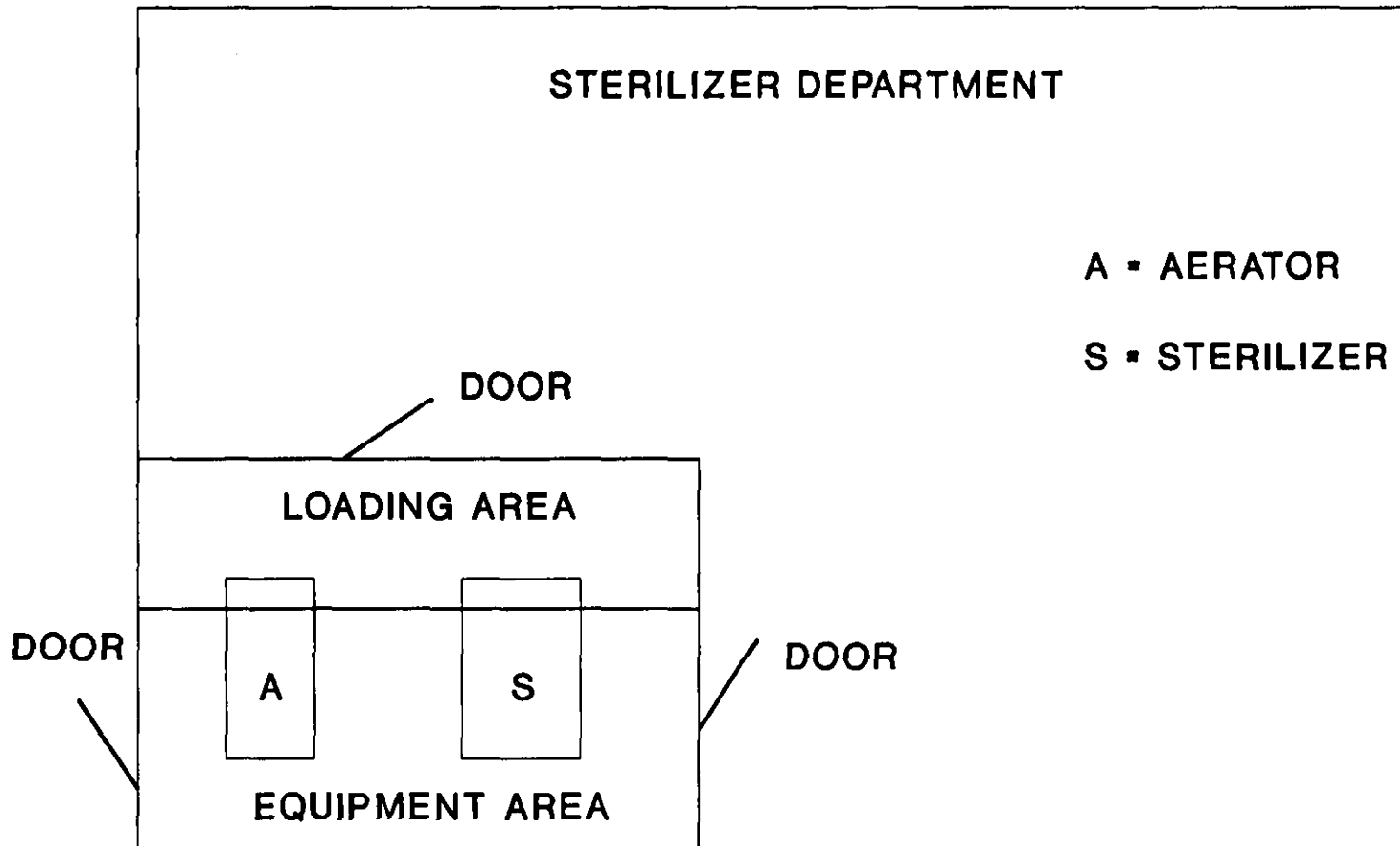

Figure B-1. Layout of the EtO Sterilizer Evaluated in the HAZOP.

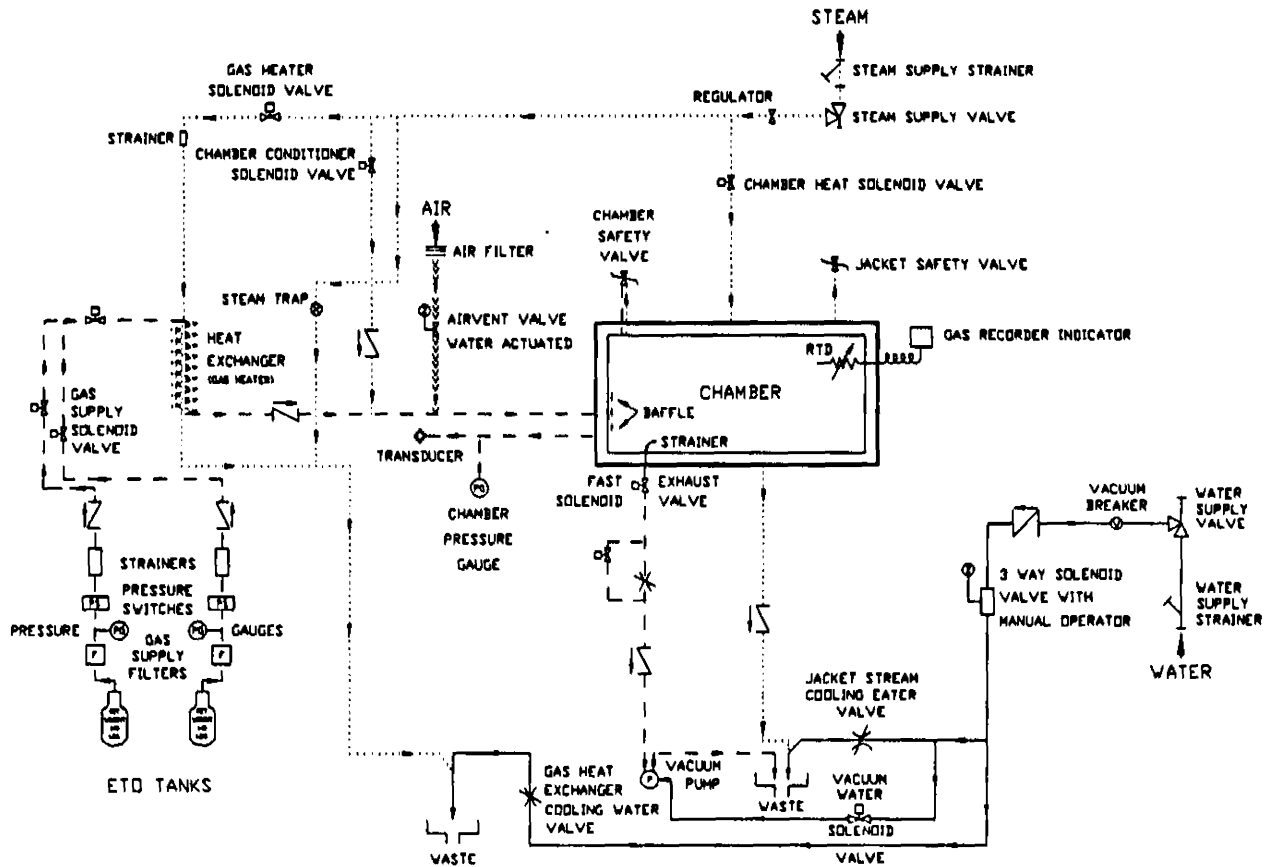

Figure B-2. Piping and Instrumentation Diagram for the EtO Sterilizer Evaluated in the HAZOP.

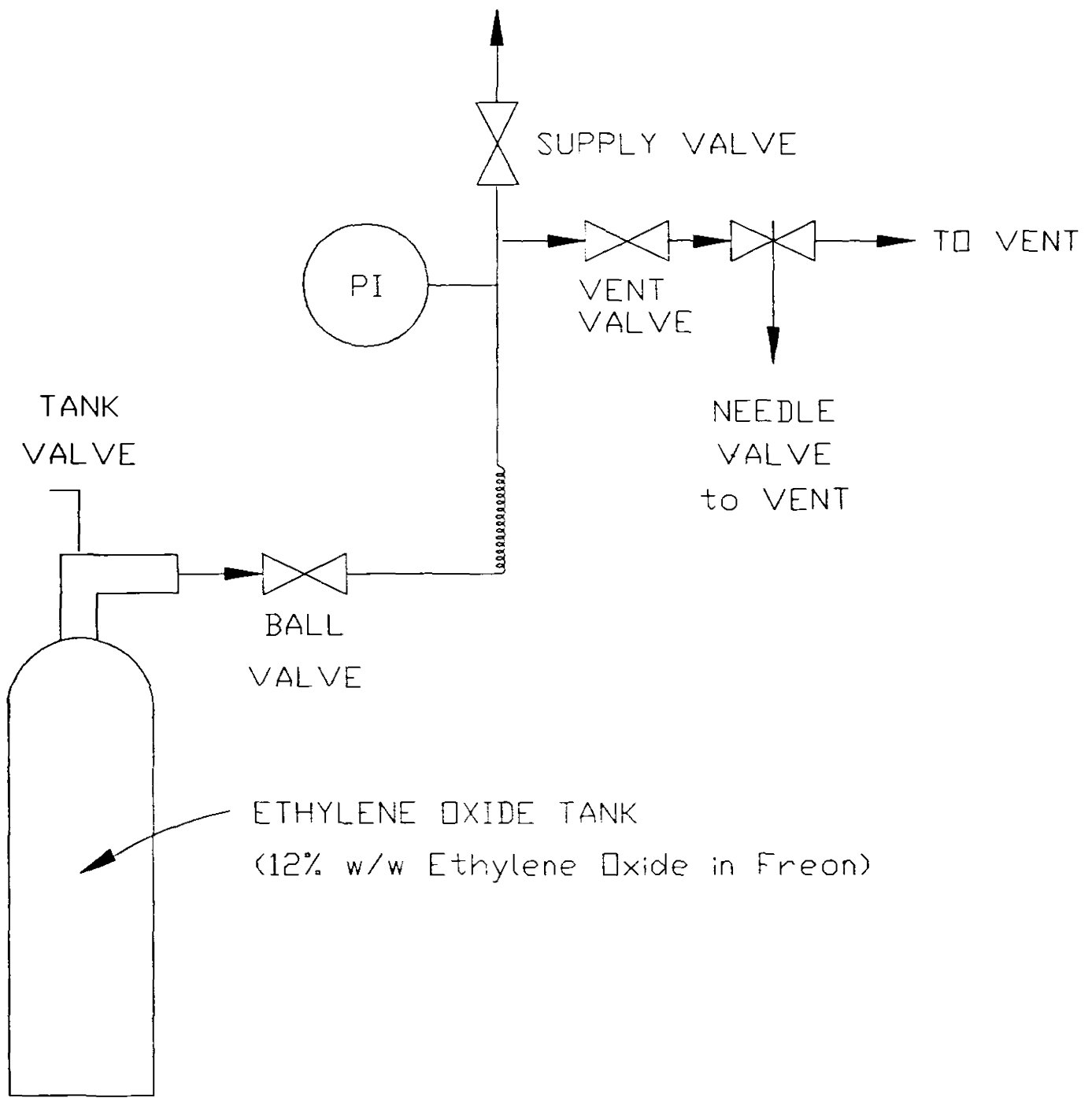
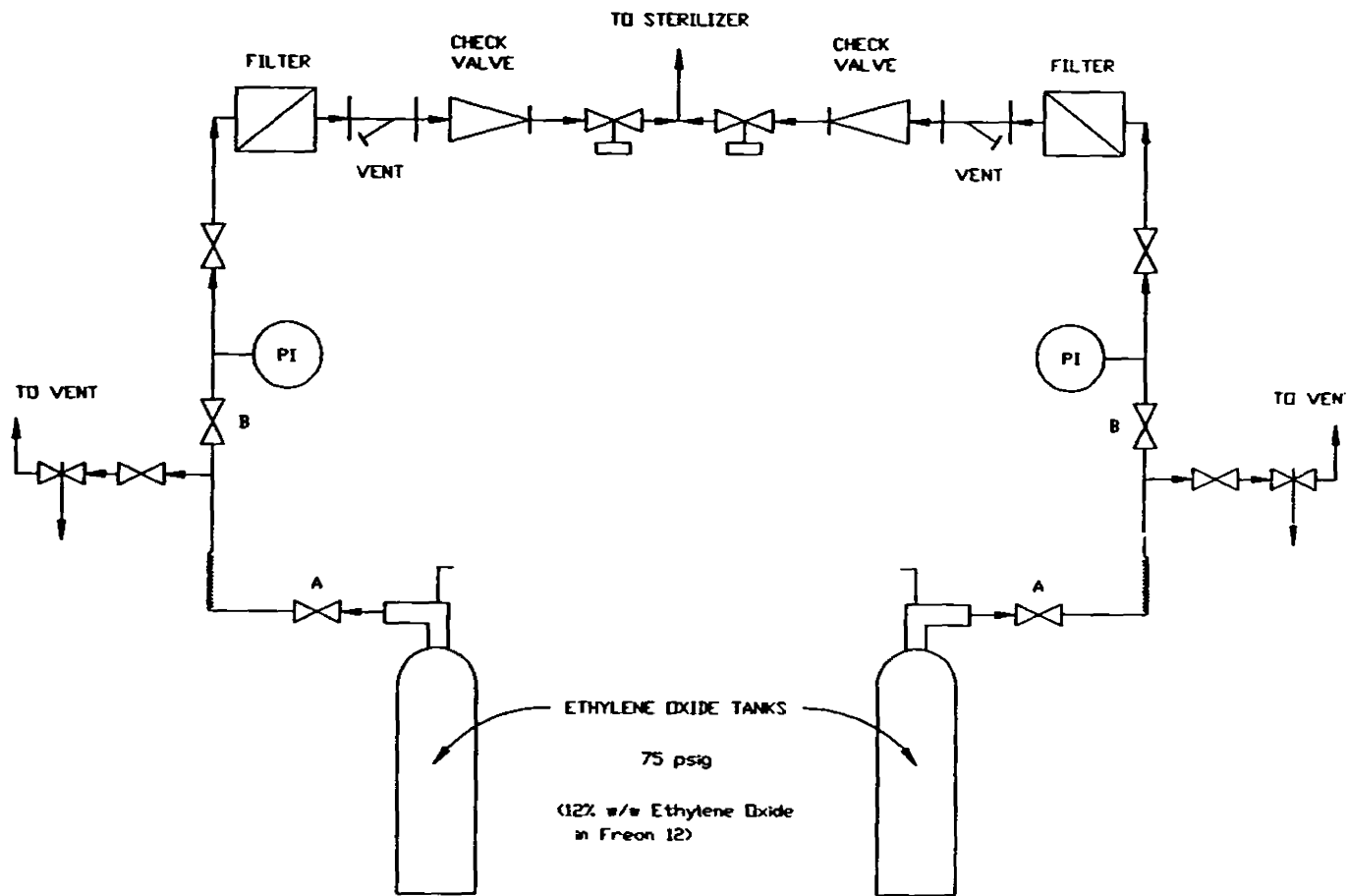
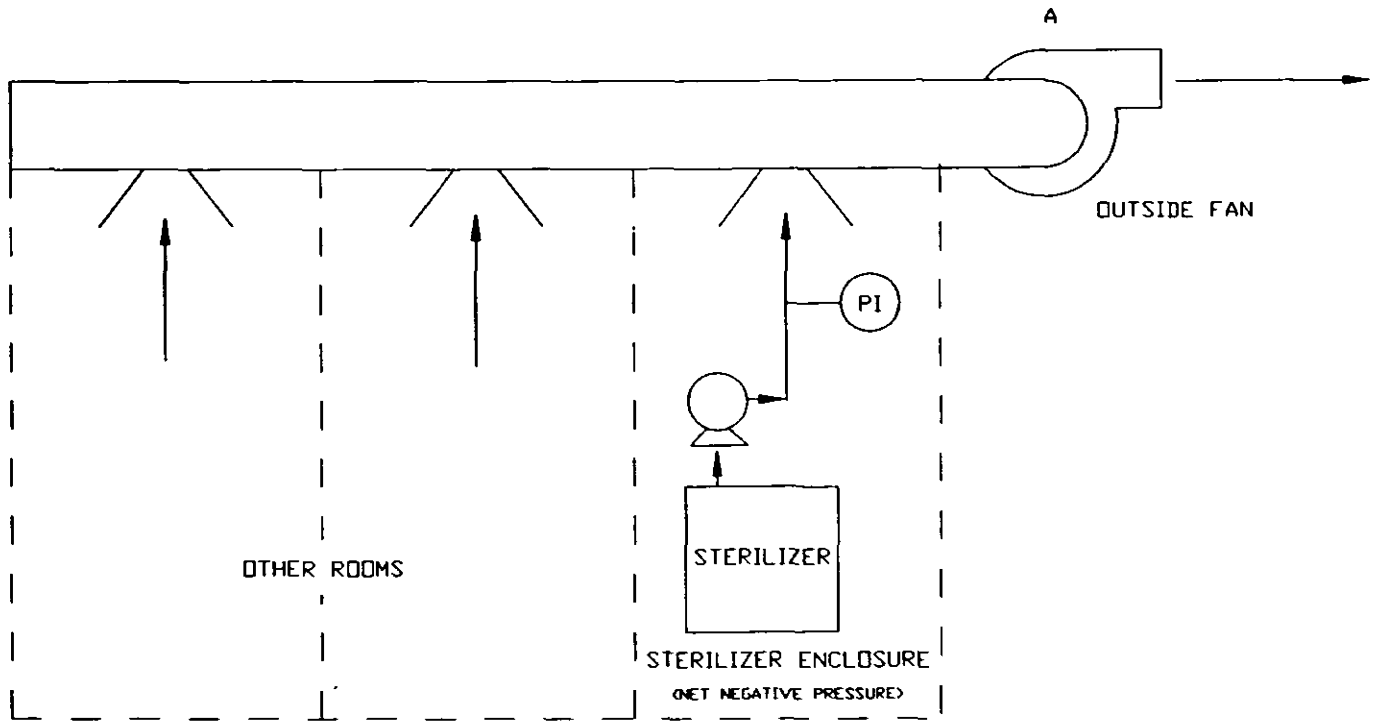

Figure B-3. Labeling of Valve on the EtO Supply Line.



**Figure B-4. Piping for Transport of EtO/Freon from the Supply Cylinders to the Sterilizer.**



**Figure B-5. Schematic of a Dedicated Dilution Exhaust for the EtO Sterilizer.**

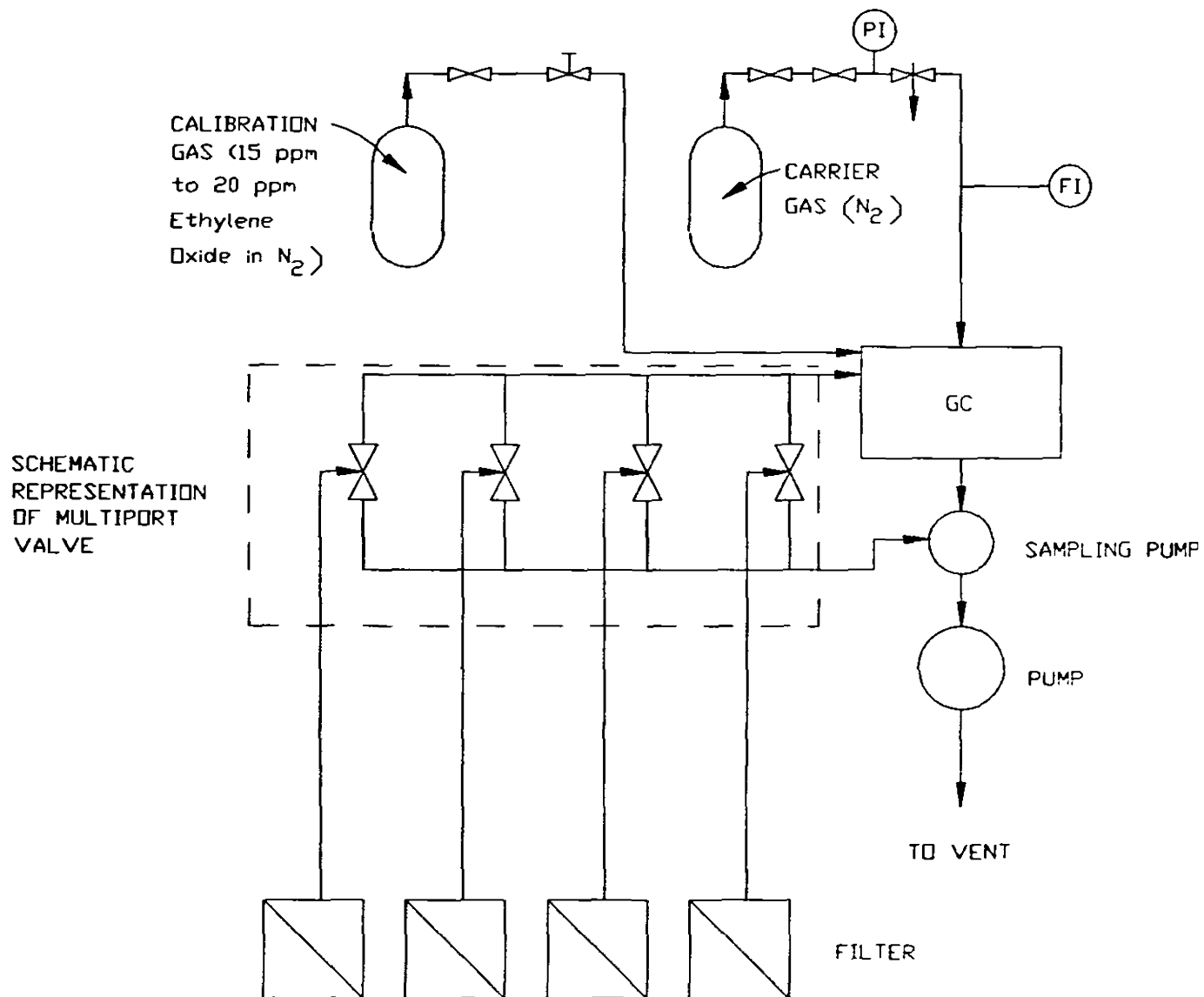

Figure B-6. Schematic of Area Monitoring System for EtO.

Table B-1. HAZOP Guideword List.

---

PART I - Process Parameters

|             |   |
|-------------|---|
| Flow        | No Flow<br>Reverse Flow<br>More Flow<br>Less Flow |
| Level       | More Level<br>Less Level                          |
| Pressure    | More Pressure<br>Less Pressure                    |
| Temperature | More Temperature<br>Less Temperature              |
| Viscosity   | More Viscosity<br>Less Viscosity                  |

---

PART II - Other Items

Composition Change  
Contamination  
Pressure Relief  
Instrumentation  
Sampling  
Corrosion/Erosion  
Service Failure  
Abnormal Operation  
Maintenance  
Static Electricity  
Spare Equipment  
Safety

---

Table B-2. HAZOP Analysis of EtO/Freon Supply Cylinders

| GUIDEWORD/<br>DEVIATION | POSSIBLE CAUSES             | POSSIBLE CONSEQUENCES   | ACTIONS/QUESTION/RECOMMENDATION   |
|-------------------------|-----------------------------|-------------------------|---|
| SAFETY                  | High temperature.           | High pressure.          | <p>Store tanks in well ventilated area below 100°F. Follow storage regulations of pressurized ethylene oxide gas (use of caps, etc.).</p> <p>Allow ethylene oxide tanks to achieve room temperature before use.</p>   |
|                         | Faulty or damaged cylinder. | Ethylene oxide release. | <p>Develop a transportation route to avoid patient areas, and transport one tank at a time using a cart with a holding strap.</p> <p>Check for leaks from tanks using a halogen leak detector, or other appropriate leak detector, before transporting to equipment room, after transporting, and after connecting to piping. If ethylene oxide tank is dropped, assume leaking. If an audible or visible leakage, assume a severe leak and leave area immediately.</p> |



Table B-3. HAZOP Analysis of Piping and Valves for EtO Transport from the Storage Cylinders to the Sterilizer Unit (Refer to Figure B-4).

| GUIDEWORD/<br>DEVIATION           | POSSIBLE CAUSES  | POSSIBLE CONSEQUENCES   | ACTIONS/QUESTION/RECOMMENDATION   |
|-----------------------------------|--|---|---|
| NO FLOW                           | Closed valve in line or ethylene oxide tank is empty.                                  | No hazard.  | No safety issue.  |
| REVERSE FLOW                      | Ethylene oxide tank is not present and valves A and B are open, and check valve fails. | Flow of trapped material into equipment room.   | Written procedures should be placed near valve B indicating that the valve should not be open while changing ethylene oxide tanks.  |
| HIGH FLOW<br>(CONTINUOUS RELEASE) | Broken line or hose due to an accidental break.  | Damage to piping or other equipment.<br>Chemical burns. Pool of ethylene oxide forms. | Instruction to operator must be to leave the room and initiate emergency procedures.<br><br>Respirator equipment should be close by equipment room (room where ethylene oxide sterilizer, tanks, and piping are located).<br><br>Equipment room should have two exits.<br><br>All ethylene oxide tanks should be located in one general area. |

(continued)

Table B-3 - continued

| GUIDEWORD/<br>DEVIATION | POSSIBLE CAUSES | POSSIBLE CONSEQUENCES | ACTIONS/QUESTION/RECOMMENDATION   |
|-------------------------|-----------------|-----------------------|---|
| HIGH FLOW<br>(CONT.)    |                 |                       | <p>Piping design should follow the code for medical gases and NFPA 99 codes (fire codes). NFPA code recommends that copper containing alloys are not suitable for ethylene oxide. This is the case if the ethylene oxide contains acetylene as a contaminant. Since all U.S. manufactured ethylene oxide now contains no acetylene, copper piping is considered here to be acceptable. This should specify hard copper tubing, silver solder joints, and adequate supporting. The piping diameter (1/4" min.) and routing should be chosen to minimize the liquid inventory. Piping should be labeled to identify it as carrying ethylene oxide. The ethylene oxide piping should not be adjacent to steam lines.</p> <p>Operators and maintenance staff should be trained in the hazards of ethylene oxide and Freon 12 according to OSHA regulations.</p> |

134

(continued)

Table B-3 - continued

| GUIDEWORD/<br>DEVIATION | POSSIBLE CAUSES | POSSIBLE CONSEQUENCES | ACTIONS/QUESTION/RECOMMENDATION   |
|-------------------------|-----------------|-----------------------|---|
| HIGH FLOW<br>(CONT.)    |                 |                       | <p>The atmosphere in the equipment room should be monitored to provide a gross leak alarm in the case of an accidental release. A suitable alarm concentration would be to a maximum of 100 ppm. The monitor should be tested periodically at the manufacturer's recommended frequency or every three months, whichever comes first. An organic vapor detector would be suitable. Alternatively, GC equipment could be used. The sampling point should be located in the approximate breathing zone in the loading area, near potential leak sources.</p> <p>The equipment room ventilation, loading room (room in which the sterilizer loading/unloading takes place), ventilation, and machine exhaust should be routed to a dedicated ventilation system, separate from other systems. It should be sized to maintain a negative pressure in equipment room relative to loading room, and a negative pressure in loading room relative to all other areas, if for example, a tank hose were to</p> |

(continued)

Table B-3 - continued

| GUIDEWORD/<br>DEVIATION     | POSSIBLE CAUSES                                   | POSSIBLE CONSEQUENCES  | ACTIONS/QUESTION/RECOMMENDATION   |
|-----------------------------|---|--|---|
| HIGH FLOW<br>(CONT.)        |   |  | rupture; (this corresponds to a 5.4 lb/s release). A recirculation ventilation system is not safe for ethylene oxide areas.   |
| LESS FLOW                   |   | No hazard.   | No safety issue.  |
| MORE<br>PRESSURE            | Equipment room temperature increases warmer tank. | Ethylene oxide leakage around tank valve.<br>Polymerization in tank. | Vent should be sized to ensure that temperature in equipment room should be less than 100°F as specified by ethylene oxide gas distributor.   |
| LOW<br>PRESSURE             |   |  | No safety issue.  |
| HIGH TEMP.<br>(NON-AMBIENT) | High room temperature.<br>Steam leak onto tank.   | High pressure.<br>Possible fusing of fusible plug.                   | Same as for more pressure.<br>When working on pressurized ethylene oxide system, (e.g., when changing cylinders, protective equipment should be worn, including face shield and gloves), facilities should be provided to allow rapid washing off of any spillage or splashing to the skin (e.g., a safety shower). |

(continued)

Table B-3 - continued

| GUIDEWORD/<br>DEVIATION | POSSIBLE CAUSES  | POSSIBLE CONSEQUENCES   | ACTIONS/QUESTION/RECOMMENDATION   |
|-------------------------|--|---|---|
| COMPO-<br>SITION        | Composition in tank has pure ethylene oxide (no Freon 12). | Explosion or fire.  | <p>Inspection for correct labeling (usually by color and sticker) of newly arrived ethylene oxide and Freon tanks should be done. Tanks should be stored in an isolated area. Operator should ensure that the proper ethylene oxide and Freon tank is hooked up to sterilizer.</p> <p>A sign saying "Check tank label for proper ethylene oxide and Freon composition" should be posted in the storage room.</p>                          |
| CONTAMI-<br>NATION      | Dirt contaminates process stream while making couplings.   | Filter should remove.   | No safety issue.  |
| RELIEF<br>(VENTING)     | Blocked needle valve in vent line.                         | No depressurization of hose and line between valves A and B (see Figure 2). | <p>A system of two isolation valves should be present on ethylene oxide inlet lines. Addition of a bleed between the two valves would reduce the consequence of leakage. Alternatively, addition of a pressure indicator between the valves would allow leak detection. Move or add the pressure indicator to position upstream of valve B. This configuration is shown in Figure B-4. The recommended configuration is shown in B-3.</p> |

137

(continued)

Table B-3 - continued

| GUIDEWORD/<br>DEVIATION             | POSSIBLE CAUSES   | POSSIBLE CONSEQUENCES                                     | ACTIONS/QUESTION/RECOMMENDATION  |
|-------------------------------------|---|---|--|
| MAINT-<br>ENANCE                    | Leak from valve stems,<br>joints, etc.                          | Low concentrations of<br>ethylene oxide in<br>atmosphere. | Carry out regular check for leaks<br>around fittings using an<br>appropriate leak detector (i.e., a<br>halogen or hydrocarbon leak<br>detector). |
| SAFETY                              | Major leaks.  | High concentration of<br>ethylene oxide in area.          | Develop a contingency plan for use<br>when a major leak occurs. See<br>Operational Procedure 9.  |
| (SECURITY)                          | Unauthorized entrance<br>into equipment room or<br>access area. | Equipment misuse.<br>Exposure to ethylene<br>oxide.       | Equipment room should be marked,<br>and a locked door should be<br>used if possible.   |
| (HAZARDS<br>OF PROCESS<br>MATERIAL) |   |   | See recommendations for high flow.   |
| (EMERGENCY<br>EQUIPMENT)            |   |   | See recommendations for high flow.   |

Table B-4. HAZOP Analysis of EtO Introduction into the Sterilizer  
(Refer to Figure B-2).

| GUIDEWORD/<br>DEVIATION | POSSIBLE CAUSES                                 | POSSIBLE CONSEQUENCES   | ACTIONS/QUESTION/RECOMMENDATION  |
|-------------------------|---|---|--|
| NO FLOW                 |   | No hazard.  | No safety issue.   |
| REVERSE<br>FLOW         |   | Not possible.   | No safety issue.   |
| MORE FLOW               | Solenoid valve opens when chamber door is open. | Ethylene oxide transport through piping.                      | An interlock is required to ensure that the ethylene oxide inlet valve (or valves) cannot open unless the chamber door is locked.  |
|                         | Regular wear on solenoid valves.                | Leakage of solenoid valves.                                   | A system of two isolation valves should be present on ethylene oxide inlet lines. Addition of a bleed between the two valves would reduce the consequence of leakage. In addition, the addition of a pressure indicator between the valves would allow leak detection. Move or add the pressure indicator to position upstream of valve B in Figure B-3. |
| MORE FLOW               | Pressure switch fails.                          | - Relief valve on chamber lifts.<br><br>- Failed door gasket. | Chamber relief valve should be routed to the dedicated ethylene oxide ventilation system.<br><br>Door gasket should be inspected before each use; replace when necessary.  |

(continued)

Table B-4 - continued

| GUIDEWORD/<br>DEVIATION                     | POSSIBLE CAUSES   | POSSIBLE CONSEQUENCES   | ACTIONS/QUESTION/RECOMMENDATION   |
|---|---|---|---|
| LESS FLOW                                   | General use.  | - Longer time to pre-<br>surize. Fails after time<br>limit.   | No safety issue.  |
| LESS PRES-<br>SURE                          | Steam vent line from<br>heat exchanger is<br>blocked.       | Higher temperature in<br>ethylene oxide and<br>polymer forms.   | No safety issue.  |
| LOW TEMP.<br>IN ETHY-<br>LENE OXIDE<br>LINE | Hot chamber contains<br>liquid ethylene oxide<br>and Freon. | - No safety hazard if<br>relief valve is<br>adequately sized.<br><br>- Rapid evaporation of<br>ethylene oxide & Freon.<br><br>- Overpressure in<br>chamber. | Relief valve should be sized for<br>maximum liquid feed rate to hot<br>chamber, assuming all liquid will<br>evaporate.  |
| SERVICE<br>FAILURE                          | Power failure during<br>sterilization steps.                | - Sequence stops.<br><br>- Valves close.  | Manual venting arrangement for<br>power failure should not be used as<br>this could lead to ethylene oxide<br>exposure to operator. It is<br>recommended that either the manual<br>vent valve be disabled, or only<br>used under careful management<br>control. |



Table B-5. HAZOP Analysis of Routine Sterilizer Operation.

| STEP                               | GUIDEWORD/<br>DEVIATION | POSSIBLE CAUSES                               | POSSIBLE CONSEQUENCES  | ACTIONS/QUESTION/<br>RECOMMENDATION |
|------------------------------------|-------------------------|---|--|-------------------------------------|
| WARMUP                             | SAFETY<br>HAZARDS       | Setting temperature higher than 130°F.        | Contact burns - alarm sounds at 160°F.   | No safety issue.                    |
|                                    |                         | Misreading of temperature (high or low).      | Out of limits - won't start.   | No safety issue.                    |
|                                    |                         | Misreading of pressure (high or low).         | Out of limits - won't start.   | No safety issue.                    |
| PREHEAT                            | SAFETY<br>HAZARDS       | Timer malfunctions.                           | No hazard.   | No safety issue.                    |
| EVACUATION<br>AND STEAM<br>PULSING | SAFETY<br>HAZARDS       | Air or steam leakage into chamber.            | Causes higher pressure or pumps work harder.<br>No hazard.                                   | No safety issue.                    |
|                                    |                         | Vacuum switch faulty.                         | - Pressure not achieved. No hazard.<br><br>- Overpressurize chamber possible, but no hazard. |                                     |
|                                    |                         | Air in chamber during evacuation.             | No hazard.   |                                     |
|                                    |                         | Faulty reading of pressure during evacuation. | Too long in cycle - alarm sounds. No hazard.   |                                     |

(continued)

Table B-5 - continued

| STEP                   | GUIDEWORD/<br>DEVIATION | POSSIBLE CAUSES   | POSSIBLE CONSEQUENCES   | ACTIONS/QUESTION/<br>RECOMMENDATION   |
|------------------------|-------------------------|---|---|---|
| CHARGING<br>WITH ETO   | NO FLOW                 |   | Alarm from watchdog timer.  | No unresolved safety issue.   |
|                        | MORE FLOW               | Leakage in heat exchanger (tubes).  | Steam carries ethylene oxide gas to drain.                          | No unresolved safety issue.   |
|                        |                         | Reverse flow into steam line.   | No real chance of leakage to steam.                                 | No safety issue.  |
|                        |                         | Reverse flow into air line via leaking valve.   | Ethylene oxide leak to equipment room.                              | Air inlet to chamber should not pick up air from equipment room, but from exhaust duct to reduce risk from reverse leakage of ethylene oxide. |
|                        | SAFETY HAZARD           | Prior evacuation of air was not achieved; begins to charge with ethylene oxide and Freon. | No hazard to operators - not sure of sterility of load.             | See Operational Procedure 2b.   |
| STERILIZING<br>PROCESS | SAFETY HAZARD           | Leakage of ethylene oxide and Freon.  | Notification by computer printouts and alarms if leakage is severe. | No unresolved safety issue.   |
| EVACUATION             | SAFETY HAZARD           | Rapid depressurization of chamber.  | Overloading of vent (exhaust) system at the plumbing gap.           | Maximum exhaust rate of gas from chamber must not exceed ventilation system capacity.   |

142

(continued)

Table B-5 - continued

| STEP                          | GUIDEWORD/<br>DEVIATION         | POSSIBLE CAUSES  | POSSIBLE CONSEQUENCES                         | ACTIONS/QUESTION/<br>RECOMMENDATION  |
|-------------------------------|---------------------------------|--|---|--|
| EVACUATION<br>AND AIR<br>WASH | LEAKAGE OF<br>ETHYLENE<br>OXIDE | Faulty pressure switch<br>allows cycle to step on<br>without proper<br>evacuation. | Open door when not<br>actually safe to do so. | See Operating Procedures<br>2b and 2c. Also, an<br>interlock is required<br>to ensure that the<br>ethylene oxide inlet<br>valve (or valves) cannot<br>open unless the chamber<br>door is locked.<br><br>Add a 20 min. air wash<br>procedure if not already<br>on system. |

Table B-6. Safe Practices for Sterilizer Operating Procedures.

---

1. Loading

- a) Packaging must be freely permeable to ethylene oxide in both directions. All plastic bags are not suitable (e.g. "green bags").
- b) Loading carts or baskets should be used, to ease the unloading process. No load should be placed in the sterilizer which would require the operator to unload articles separately.
- c) Soiled goods should be cleaned before packaging. Goods sterilized by ethylene oxide should be only those which cannot be sterilized another way.
- d) Loading should not be so dense as to prevent complete circulation of gas around each package.

2. Unloading a Load Which Has Not Been Fully Aerated

(Typical procedure for larger sterilizers.)

- a) Whenever possible, a load should be aerated in the sterilizer.
  - b) On completion of cycle, check that cycle completed properly on the chart or print out. If not, follow procedure for an incomplete cycle.
  - c) Open door 2-3 inches to allow local ventilation system to capture the chamber off-gas. Leave door in this position for 15 minutes. Operator should leave area during this time.
  - d) Prepare aerator for loading before opening door.
  - e) Open door. Unload cart to transport cart. Operator should draw cart out, moving backwards in front of cart. Operator should avoid entering chamber, and keep as much distance from load as possible.
  - f) Ensure that upper cart locks onto transport cart.
  - g) Biological indicators should normally be removed only after aeration. If biological indicator is to be removed from nonaerated load, this should be done with minimum operator contact with the load, and with air flow from operator to load. Incorrect practices in removal of biological indicators from a nonaerated load could give significant exposure to the operator.
  - h) Where possible, pull load to aerator on cart, keeping distance between operator and load wherever possible. This ensures rising plume of
- 

(continued)

Table B-6 - continued

---

off-gas from load is left behind cart, rather than rising towards the operator.

- i) Uncouple upper cart and push into aerator. It is not recommended that the cart is unloaded into the aerator, as operator exposure would be greater. Close door of aerator and start cycle. Aerate for full recommended time for the goods being aerated.

3. Unloading Aerated Load

At this time there should be no hazards, and therefore no specific recommendations are given.

4. Specific Practices to Avoid

- a) Do not leave a nonaerated load in the room while awaiting space in the aerator.
- b) Do not wipe out the sterilizer between loads. If the sterilizer must be cleaned out, a specific safe practice will be required which must ensure that ethylene oxide is isolated from the machine.
- c) Operating practices must avoid the need for head or body part to enter the sterilizer chamber.
- d) Do not pick up a nonaerated load.
- e) Do not enter equipment room during exhaust cycle. It is better that no personnel be in this room while the sterilizer is running. It should not be used for any other activities.

5. Procedure if Sterilizer System Hangs Up, or Alarms, or If Any Abnormal Indication Appears After Cycle Completion

- a) Contact supervisor, do not unload the machine, until authorized to do so.
- b) If the apparent problem could involve maintenance, the service organization may also be contacted.

6. Preparation of Sterilizer for Maintenance.

1. Maintenance should only be carried out by specifically trained staff.
- 

(continued)

Table B-6 - continued

- 
2. No general maintenance procedure can be given, as different machines will require different specific procedures. However, the following guidelines should be considered.
    - a) When working on the chamber, etc., the gas bottles should be disconnected, and lines depressurized and preferably purged with Freon 12, or other purge gas compatible with system.
    - b) When investigation shows leaks on the charge system, the lines should normally be purged first with Freon 12 and this medium used to determine leak detection. If this is not possible, appropriate personal protection should be used.
  3. During maintenance, operators must be informed not to operate the machine. A sign on the operators panel should indicate that maintenance is in progress.
  4. Maintenance personnel should normally carry a personal monitor with alarm capability, while working on ethylene oxide sterilizers.
7. Preparation for Prolonged Shutdown
1. Isolate all services (not monitors, unless gas bottles are removed).
  2. Isolate gas by shutting off all appropriate valves so as to vent any EtO that may be trapped in the lines.
  3. Consideration should be given to taking gas bottles back to storage.
  4. Doors should be closed, but not locked (for immediate access, in case of emergency).
8. Post Maintenance Testing
1. Leak test any gas piping which has been disturbed.
  2. Run a test cycle, to ensure that problem has been cured, before returning machine to service.
9. Emergencies in Sterilizer Area
1. Firefighters should be aware that pressurized gas is stored in the area, and that it is a nonflammable toxic gas.
  2. Normal sprinkler systems are acceptable for the equipment room, loading room, etc.
-

Table B-7. HAZOP Analysis of the Air Supply for Vacuum Relief in the EtO Sterilizer

| GUIDEWORD/<br>DEVIATION | POSSIBLE CAUSES    | POSSIBLE CONSEQUENCES   | ACTIONS/QUESTION/RECOMMENDATION   |
|-------------------------|--------------------|---|---|
| NO FLOW                 | - Valve closed.    | - Machine hang up - No hazard.                                | No safety issue.  |
|                         | - Filter plugged.  | - Machine hang up. No hazard. Takes too long, alarm goes off. |   |
|                         | - Too much vacuum. | - Deep vacuum, can't open door - No hazard.                   |   |
| REVERSE<br>FLOW         |                    | Air line should be connected to vent.                         | Air inlet to chamber should not pick up air from equipment room, but from exhaust duct to reduce risk from reverse leakage of ethylene oxide. |
| HIGH FLOW               |                    |   | No safety issue.  |
| LESS FLOW               | Partial blockage.  | Takes longer - No hazard.                                     | No safety issue.  |
| HIGH PRES-<br>SURE      |                    | No hazard.  | No safety issue.  |
| LESS PRES-<br>SURE      |                    | No hazard.  | No safety issue.  |
| HIGH TEMP.              |                    | No hazard.  | No safety issue.  |

(continued)

Table B-7 - continued

| GUIDEWORD/<br>DEVIATION | POSSIBLE CAUSES  | POSSIBLE CONSEQUENCES   | ACTIONS/QUESTION/RECOMMENDATION |
|-------------------------|--|---|---------------------------------|
| LOW TEMP.               |  | No hazard.  | No safety issue.                |
| VISCOSITY               |  | No hazard.  | No safety issue.                |
| COMPO-<br>SITION        | Draw in contaminated<br>air (exhaust from other<br>equipment) from vent. | Concentration is too low<br>to cause hazard.  | No safety issue.                |
| CONTAM-<br>INATION      | Biological contami-<br>nation.   | Filter takes care of<br>problem.  | No safety issue.                |
| INSTRU-<br>MENTATION    | Leaking valve - air<br>leaks in.   | Chamber doesn't reach<br>required vacuum for<br>function steps. Notified<br>by watchdog alarm - No<br>hazard. | No safety issue.                |
| SERVICE<br>FAILURE      | Loose water supply to<br>water actuated valve.                           | Can't open valve -<br>system hangs.   | No safety issue.                |



Table B-8. HAZOP Analysis for the Steam Supply to the EtO Sterilizer.

| GUIDEWORD/<br>DEVIATION | POSSIBLE CAUSES   | POSSIBLE CONSEQUENCES   | ACTIONS/QUESTION/RECOMMENDATION  |
|-------------------------|---|---|--|
| NO FLOW                 | <ul style="list-style-type: none"> <li>- Valve doesn't open.</li> <li>- No steam.</li> <li>- Plugged steam line (due to crud).</li> </ul> | <ul style="list-style-type: none"> <li>- Cycle won't proceed since it looks to see a pressure change.</li> <li>- If it gets through cycle, proper sterilization is not achieved. No hazard to employees.</li> </ul> | No safety issue.   |
| HIGH FLOW               | Valve sticks open.  | <ul style="list-style-type: none"> <li>- High pressure in chamber.</li> <li>- High temperature.</li> <li>- Machine aborts cycle.</li> </ul>   | No safety issue. Unlikely to go above atmospheric pressure because running vacuum pump at the same time. |
| LESS FLOW               | Steam line blockage.  | Cycle takes longer.   | No safety issue.   |
| HIGH PRES-<br>SURE      | Steam valve stays open.   | No hazard for line.   | No safety issue.   |
| LOW PRES-<br>SURE       |   | No hazard; designed for vacuum.   | No safety issue.   |
| HIGH TEMP.              | Steam valve doesn't close when supposed to.   | <ul style="list-style-type: none"> <li>- System designed to handle it.</li> <li>- Damage of load, print-out saying load is damaged.</li> </ul>  | No safety issue.   |

(continued)

Table B-8 - continued

| GUIDEWORD/<br>DEVIATION       | POSSIBLE CAUSES | POSSIBLE CONSEQUENCES   | ACTIONS/QUESTION/RECOMMENATION |
|-------------------------------|-----------------|---|--------------------------------|
| HIGH TEMP.<br>(CONT.)         |                 | <ul style="list-style-type: none"> <li>- If pressure too high, relief valve opens.</li> <li>- Can't open door if this is the case.</li> </ul>               |                                |
| COMPO-<br>SITION              |                 | No problem.   | No safety issue.               |
| CONTAM-<br>INANTS IN<br>STEAM | Boiler fault.   | <ul style="list-style-type: none"> <li>- System should be able to handle it.</li> <li>- Corrodes at high levels.</li> <li>- Maintenance problem.</li> </ul> | No safety issue.               |
| RELIEF                        |                 | Piping can withstand max. steam pressure - No hazard.   | No safety issue.               |
| SERVICE<br>FAILURE            | No steam.       | Pressure not achieved; hangs up.  | No safety issue.               |

Table B-9. HAZOP Analysis for the Drain Line from the Sterilizer.

| GUIDEWORD/<br>DEVIATION | POSSIBLE CAUSES  | POSSIBLE CONSEQUENCES  | ACTIONS/QUESTION/RECOMMENDATION  |
|-------------------------|--|--|--|
| NO FLOW                 | <ul style="list-style-type: none"> <li>- No water flow.</li> <li>- Closed valve in line.</li> <li>- Pump not running.</li> </ul> | <ul style="list-style-type: none"> <li>- No vacuum level achieved for additional steps (stops cycle).</li> <li>- Ethylene oxide goes to vent.</li> </ul> | No safety issue.   |
| REVERSE<br>FLOW         | Exhaust valve fails,<br>other valvea fail.   | Water into chamber. No<br>hazard.  | No safety issue.   |
| MORE FLOW               |  |  | <p>The loading room ventilation should maintain a pressure lower than that in surrounding areas not containing ethylene oxide. The equipment room ventilation should maintain a pressure below that of the loading room. It is suggested to have separate containment rooms (one for the equipment room, and a second for the loading/unloading room). Where separate loading and unloading rooms are provided, these should both be maintained at a lower pressure than surrounding areas. Efficient ventilation would require a high level exhaust outlet and a low level supply inlet because of thermal stratification (exhaust above supply).</p> |

Table B-9 - continued

| GUIDEWORD/<br>DEVIATION | POSSIBLE CAUSES | POSSIBLE CONSEQUENCES  | ACTIONS/QUESTION/RECOMMENDATION   |
|-------------------------|-----------------|--|---|
| MORE FLOW<br>(CONT.)    | Drain plugs.    | <p>Water with ethylene oxide on floor; creates emergency situation.</p> <p>High concentration sensed in equipment room.</p> <p>If interlock is on:</p> <ul style="list-style-type: none"> <li>- Goes into exhaust cycle.</li> <li>- Closes ethylene oxide charging valve.</li> <li>- Closes valve S3 to avoid dump.</li> </ul> | <p>The minimum velocity at the vents connecting the loading room and operating room should be 100 ft./min. to overcome normal air movements. Louvers to the exhaust duct should be located above each door into each area. A slot hood should be located above the loading/unloading door of the sterilizer. The area ventilation should be to a dedicated exhaust system.</p> <p>Hospital should have an emergency procedure for this case. Avoid continuing cycle if drain is known to be plugged (do this by cutting power to sterilizer).</p> <p>Where practical, a dedicated drain section should be used connecting to a main drain line, to reduce risk of blockage.</p> |

Table B-9 - continued

| GUIDEWORD/<br>DEVIATION | POSSIBLE CAUSES  | POSSIBLE CONSEQUENCES   | ACTIONS/QUESTION/RECOMMENDATION                          |
|-------------------------|--|---|--|
| MORE FLOW<br>(CONT.)    |  | <ul style="list-style-type: none"> <li>- Alarm sounds.</li> <br/> <li>If splashes away from funnel, ethylene oxide is picked up by ventilation. No hazard.</li> </ul> |  |
| LESS FLOW               |  | Cycle takes longer.   | No safety issue.   |
| HIGH PRES-<br>SURE      |  | Can handle high pressure.   | No safety issue.   |
| LESS PRES-<br>SURE      |  | Designed for low pres-<br>sure.   | No safety issue.   |
| HIGH TEMP.              |  | <ul style="list-style-type: none"> <li>- Less efficient on cycle.</li> <br/> <li>- Pump is dry. Damage to pump. No hazard.</li> </ul>                                 | No safety issue.   |
| CONTAM-<br>INANTS       | Line contains contam-<br>inants.   | Strainer removes any (if not - no flow).  | Strainer in chamber should be inspected before each use. |
| INSTRU-<br>MENTATION    | <ul style="list-style-type: none"> <li>- Plugged restrictor (needle valve).</li> <br/> <li>- Valve doesn't open.</li> <br/> <li>- Valve doesn't open.</li> </ul> | <ul style="list-style-type: none"> <li>- Hangs up.</li> <br/> <li>- Cycle takes longer.</li> <br/> <li>- Hangs up, watchdog alarm.</li> </ul>                         | No safety issue.   |

Table B-10. HAZOP Analysis for the Pressure Relief and Temperature Recorder/Indicator on the Sterilizer.

| GUIDEWORD/<br>DEVIATION | POSSIBLE CAUSES  | POSSIBLE CONSEQUENCES                              | ACTIONS/QUESTION/RECOMMENDATION  |
|-------------------------|--|--|--|
| MORE<br>PRESSURE        | Overloaded relief valve.   | Gasket failure - venting into room.                | Loading room should not be occupied during operation. The door to loading room should contain a window for observation.            |
| LOW PRES-<br>SURE       |  | Designed for vacuum. No hazard. (Can't open door). | No safety issue.   |
| HIGH TEMP.              | Maximum steam temperature reached.   | No concern.  | No safety issue.   |
| LOW TEMP.               |  | No concern.  | No safety issue.   |
| CONTAM-<br>INANTS       | Polymerization of ethylene oxide in chamber and reaction of this with water. | Polymer deposits that could retain ethylene oxide. | See Operating Procedure 4b.  |
| RELIEF                  | Relief valve sticks, or inlet plugged with lint.                             | Regular testing of valve should solve the problem. | Relief valve should be tested periodically. (Procedure for test should be carried out according to manufacturers recommendations). |

(continued)

Table B-10 - continued

| GUIDEWORD/<br>DEVIATION | POSSIBLE CAUSES                      | POSSIBLE CONSEQUENCES                      | ACTIONS/QUESTION/RECOMMENDATION   |
|-------------------------|--------------------------------------|--|---|
| INSTRU-<br>MENTATION    | Leakage around<br>temperature probe. | Picked up by leak<br>checks.               | Carry out regular check for leaks<br>around fittings using an<br>appropriate leak detector (i.e., a<br>halogen or hydrocarbon leak<br>detector).  |
|                         | Leakage of relief valve.             | Ventilation system<br>removes - No hazard. | Chamber relief valve should be<br>routed to the dedicated ethylene<br>oxide ventilation system.   |
| CORROSION               |                                      |  | No safety issue due to materials of<br>construction.  |
| SERVICE<br>FAILURE      | Steam failure.                       | No warm-up, can't get<br>into cycle.       | No safety issue.  |
| SAFETY                  | Manual valve.                        |  | Manual venting arrangement for<br>power failure should not be used as<br>this could lead to ethylene oxide<br>exposure to operator. It is<br>recommended that either the manual<br>vent valve be disabled, or only<br>used under careful management<br>control. |

Table B-11. Reliability of the Dilution Ventilation System.

| GUIDEWORD/<br>DEVIATION     | POSSIBLE CAUSES                          | POSSIBLE CONSEQUENCES   | ACTIONS/QUESTION/RECOMMENDATION   |
|-----------------------------|--|---|---|
| NO FLOW/<br>REVERSE<br>FLOW | Fan at point A stops,<br>(see Figure 4). | Back flow from steri-<br>lizer exhaust into other<br>ventilated areas during<br>exhaust cycle.              | Monitoring of pressure with a posi-<br>tive indication of failure should<br>be used. Pressure should be<br>monitored by a differential<br>pressure switch that is fail safe,<br>such that a lack of negative<br>pressure in the exhaust duct sounds<br>an alarm and inhibits the exhaust<br>cycle of the sterilizer.<br><br>Ventilation system should be sized<br>to keep temperature in area below<br>100°F. |
| HIGH FLOW                   |  | No hazard.  | No safety issue.  |
| LOW FLOW                    |  | Picked up by a differ-<br>ential pressure switch.<br>Possible failure to clear<br>ethylene oxide from area. | No safety issue.  |
| MORE PRES-<br>SURE          | Fan at point A stops,<br>(see Figure 4). | See LOU FLOW.   | The equipment room ventilation,<br>loading room (room in which the<br>sterilizer loading/unloading takes<br>place), ventilation, and machine<br>exhaust should be routed to a<br>dedicated ventilation system,<br>separate from other systems. It<br>should be sized to maintain a<br>negative pressure in equipment room<br>relative to loading room, and a  |



Table B-11 - continued

| GUIDEWORD/<br>DEVIATION    | POSSIBLE CAUSES                | POSSIBLE CONSEQUENCES                         | ACTIONS/QUESTION/RECOMMENDATION  |
|----------------------------|--------------------------------|---|--|
| MORE PRES-<br>SURE (CONT.) |                                |   | negative pressure in loading room relative to all other areas, if for example, a tank hose were to rupture; (this corresponds to a 5.4 lb/a release). A recirculation ventilation system is not safe for ethylene oxide areas. |
| HIGH TEMP.                 |                                | No hazard.                                    | No safety issue.   |
| LOW TEMP.                  |                                | No hazard - should be controlled for comfort. | No safety issue.   |
| COMPO-<br>SITION           |                                | No hazard.                                    | No safety issue.   |
| SERVICE<br>FAILURE         | Failure of ventilation system. | No ventilation.                               | Install low flow switch and alarm (alarm should be fail safe) as noted above.  |
| DISCHARGE<br>POINT         |                                |   | Check local codes for location of discharge to prevent re-entering of gases into building. Also, locate for minimal exposure to passers-by.  |
| EQUIPMENT<br>ROOM          |                                |   | Drain must be sealed. This will not violate plumbing codes as the drain piping within the sterilizer provides a plumbing gap which is not sealed. Local ventilation should be provided to the plumbing                         |

157

(continued)

Table B-11 - continued

| GUIDEWORD/<br>DEVIATION   | POSSIBLE CAUSES | POSSIBLE CONSEQUENCES | ACTIONS/QUESTION/RECOMMENDATION  |
|---------------------------|-----------------|-----------------------|--|
| EQUIPMENT<br>ROOM (CONT.) |                 |                       | <p>gap. The drain system to which the sterilizer is connected should be fitted with drain traps, to prevent gas flow. If the drain is not likely to be used, it should be capped.</p> <p>The drains local to the sterilizer should be labeled, to indicate that they may contain ethylene oxide.</p> |

Table B-12. HAZOP Analysis of the Area Monitoring Sample Transport Lines.

| GUIDEWORD/<br>DEVIATION | POSSIBLE CAUSES  | POSSIBLE CONSEQUENCES   | ACTIONS/QUESTION/RECOMMENDATION  |
|-------------------------|--|---|--|
| NO FLOW                 | - Filter plugged, or Multi-port valve on sample line is not working. | - GC will read false safe reading, but calibrates properly.   | Check that multiport valve position is correctly monitored. Device monitoring sample system should be checked to be correctly operating. |
|                         | - Pump failure (either sampling pump or vent line pump).             | - Sampling pump failure causes false readings on GC.  | Each sample line should contain a rotameter or other flow indicator.   |
|                         | - Clogged vent.  | - Vent pump and clogged vent failure causes no flow on all samples and continues to get same readings as previous ones (GC takes readings from line). | On GC systems without self calibration, a frequent manual calibration would be required.   |
| REVERSE FLOW            | Blocked vent, carrier gas reverses into sample lines.                | False safe readings, but picked up by self calibration.   | Same as above (frequent manual calibration required).  |
| HIGH FLOW               |  | No hazard.  | No safety issue.   |
| LESS FLOW               | See previous page for NO FLOW.                                       | False readings, delay in readings.  | On GC systems without self calibration, a frequent manual calibration would be required.   |

(continued)

Table B-12 - continued

| GUIDEWORD/<br>DEVIATION | POSSIBLE CAUSES   | POSSIBLE CONSEQUENCES   | ACTIONS/QUESTION/RECOMMENDATION   |
|-------------------------|---|---|---|
| HIGH<br>PRESSURE        |   | No hazard.  | No safety issue.  |
| LESS<br>PRESSURE        | Blocked filter.   | No hazard.  | No safety issue.  |
| HIGH TEMP.              | Increase temperature of<br>GC.                                      | No hazard.  | No safety issue.  |
| COMPO-<br>SITION        | Hose cut, pulling in<br>of room air.                                | False reading from GC.  | Regular checks for damage to<br>plastic tubing should be required.  |
| CONTAM-<br>INATION      | Sample line contains<br>dust or other materials.                    | Filter removal of these<br>materials.   | No safety issue.  |
| SERVICE<br>FAILURE      |   | No hazard.  | No safety issue.  |
| MAINTEN-<br>ANCE        |   |   | Regular checks for damage to<br>plastic tubing should be required.  |
| SAFETY                  | - High reading on GC.<br><br>- Low ethylene oxide<br>level (1 ppm). | - Sounds an alarm that<br>needs to be shut off<br>manually.<br><br>- Beeps for 5 secs. and<br>shuts off (does not have<br>to be reset). | Provide alarm test facility for<br>audible and visible alarm on<br>monitor.<br><br>Consider installing a remote alarm<br>to be heard inside equipment area. |

091

(continued)

Table B-12 - continued

| GUIDEWORD/<br>DEVIATION | POSSIBLE CAUSES | POSSIBLE CONSEQUENCES | ACTIONS/QUESTION/RECOMMENDATION  |
|-------------------------|-----------------|-----------------------|--|
| SAFETY<br>(CONT.)       |                 |                       | Equipment room should be free to people during exhaust cycle of sterilizer, since this is period of greatest potential exposure.<br><br>A warning indicator should be installed in equipment room that will notify sterilizer is in exhaust cycle. |

Table B-13. HAZOP of Carrier Gas Line to GC.

| GUIDEWORD/<br>DEVIATION | POSSIBLE CAUSES  | POSSIBLE CONSEQUENCES  | ACTIONS/QUESTION/RECOMMENDATION  |
|-------------------------|--|--|--|
| NO FLOW                 | <ul style="list-style-type: none"> <li>- Closed needle valve (unlikely).</li> <li>- Empty tank.</li> </ul> | <ul style="list-style-type: none"> <li>- GC gives an incorrect low reading.</li> <li>- GC detects low carrier flow.</li> <li>- GC overheats.</li> <li>- Detected by failure of self calibration (8 hrs. later).</li> </ul> | <p>Regular checks of pressure in carrier gas tank to ensure tank is changed before empty.</p> <p>Carrier gas should be handled with standard compressed gas regulations.</p> |
| REVERSE FLOW            |  | No hazard.   | No safety issue.   |
| MORE FLOW               | Needle valve setting too far open.   | Bad calibration; will know 8 hrs. later or right away if hooking up new gas tank.  | Check flow on rotameter when hooking up new carrier gas tank.  |
| LESS FLOW               | Needle valve setting too far closed.   | Picked up on calibration.  | No safety issue.   |
| HIGH PRES-SURE          | Failed regulator (unlikely).   | <p>Damaged equipment:</p> <ul style="list-style-type: none"> <li>- release of large quantity of nitrogen.</li> <li>- destroy column (compresses it). (No Hazard)</li> </ul>  | No safety issue.   |

Table B-13 - continued

| GUIDEWORD/<br>DEVIATION                     | POSSIBLE CAUSES                                  | POSSIBLE CONSEQUENCES   | ACTIONS/QUESTION/RECOMMENDATION  |
|---|--|---|--|
| LOW<br>PRESSURE                             | Low flow.  | Picked up on calibration.   | No safety issue.   |
| HIGH OR<br>LOW TEMP.                        |  | No hazard.  | No safety issue.   |
| VISCOSITY                                   |  | No hazard.  | No safety issue.   |
| COMPO-<br>SITION/<br>CONTAM-<br>INATION     | Carrier gas tank used contains other components. | Picked up on calibration (a possible situation).  | Carrier gas tanks should be stored apart from other tanks, to avoid any mix-up.  |
| RELIEF                                      |  | No hazard.  | No safety issue.   |
| SAFETY<br>(HAZARDS<br>OF NIT-<br>ROGEN GAS) | Breakage of line.                                | Leakage of nitrogen gas, but quantity insufficient to give serious asphyxiation hazard. | No safety issue.   |
| OTHER<br>MONITORING<br>SYSTEMS              | Less sensitive area detectors.                   | May not react to intermediate levels of ethylene oxide in atmosphere.                   | Personal monitors should be used on a regular basis to check for levels of actual worker exposure to ethylene oxide (carbon tube or badge type) if less sensitive monitors are used. |

(continued)

Table B-13 - continued

| GUIDEWORD/<br>DEVIATION        | POSSIBLE CAUSES | POSSIBLE CONSEQUENCES | ACTIONS/QUESTION/RECOMMENDATION   |
|--------------------------------|-----------------|-----------------------|---|
| OTHER<br>MONITORING<br>SYSTEMS |                 |                       | <p>The atmosphere in the equipment room should be monitored to provide a gross leak alarm in the case of an accidental release. A suitable alarm concentration would be to a maximum of 100 ppm. The monitor should be tested periodically at the manufacturer's recommended frequency or every three months, whichever comes first. An organic vapor detector would be suitable. Alternatively, GC equipment could be used. The sampling point should be located in the approximate breathing zone in the loading area, near potential leak sources.</p> |



**APPENDIX C:**

**INDIVIDUAL IN-DEPTH SURVEY REPORTS**

**Kercher, S. In-Depth Survey Report: Control Technology for Ethylene Oxide Sterilization in Hospitals. February 4-8, 1985. DHHS, NIOSH Report 1985 (ECTB No. 146-15b), NTIS Publ. No. PB-87-163887.**

**Kercher, S. In-Depth Survey Report: Control Technology for Ethylene Oxide Sterilization in Hospitals. March 18-22, 1985. DHHS, NIOSH Report 1985 (ECTB No. 146-18b), NTIS Publ. No. PB-86-123866.**

**Mortimer, V. In-Depth Survey Report: Control Technology for Ethylene Oxide Sterilization in Hospitals. June 11-15, 1984. DHHS, NIOSH Report 1985 (ECTB No. 146-11b), NTIS Publ. No. PB-87-164513.**

**Mortimer, V. and S. Kercher. In-Depth Survey Report: Modified Control Technology for Ethylene Oxide Sterilization in Hospitals. October 7-11, 1985. DHHS, NIOSH Report 1986 (ECTB No. 146-12c), NTIS Publ. No. PB-86-237252.**

**Mortimer, V. and S. Kercher. In-Depth Survey Report: Control Technology for Ethylene Oxide Sterilization in Hospitals. February 25 - March 1, 1985. DHHS, NIOSH Report 1985 (ECTB No. 146-13b), NTIS Publ. No. PB-89-137152.**

**O'Brien, D. In-Depth Survey Report: Control Technology for Ethylene Oxide Sterilization in Hospitals. September 24-28, 1984. DHHS, NIOSH Report 1985 (ECTB No. 146-14b), NTIS Publ. No. PB-87-164497.**

**O'Brien, D. In-Depth Survey Report: Control Technology for Ethylene Oxide Sterilization in Hospitals. January 21-25, 1985. DHHS, NIOSH Report 1985 (ECTB No. 146-17b), NTIS Publ. No. PB-86-125200.**

**Todd, W., S. Kercher, V. Mortimer, and D. O'Brien. In-Depth Survey Report: Control Technology for Ethylene Oxide Sterilization in Hospitals. October 29 - November 2, 1984. DHHS, NIOSH Report 1985 (ECTB No. 146-12b), NTIS Publ. No. PB-86-116969.**

## GLOSSARY

|                                 |  |
|---------------------------------|--|
| <b>AERATOR</b>                  | A device for the removal of ethylene oxide from sterilized materials by the exposure to the circulation of air; aeration is normally accomplished at an elevated temperature.  |
| <b>AIR FLUSH</b>                | That part of the sterilizer cycle when the vacuum pump operates continuously and a valve opens admitting filtered air into the sterilizer chamber.   |
| <b>AMPOULE</b>                  | A small glass vial containing ethylene oxide.  |
| <b>ANTISIPHON<br/>AIR GAP</b>   | A device to prevent backflow of contaminated water into the potable water system; the air gap may be partially enclosed and connected to a local exhaust system.   |
| <b>AUTOCLAVE</b>                | A pressurized, steam-heated vessel used for sterilization.   |
| <b>BIOLOGICAL<br/>INDICATOR</b> | A vial containing bacterial spores used for determination of sterilization.  |
| <b>CLEAN ROOM</b>               | The area within the hospital where washed materials are dried, inspected, and packaged.  |
| <b>DECONTAMINATION<br/>ROOM</b> | That area within the hospital where used materials are washed prior to sterilization; also known as the isolation room.  |
| <b>DEDICATED<br/>EXHAUST</b>    | An exhaust system serving only the aerator, sterilizer, and/or the immediate area.   |
| <b>DWELL PERIOD</b>             | That part of the sterilizer cycle during which sterilization takes place.  |
| <b>EVACUATION/<br/>EXHAUST</b>  | That part of the sterilizer cycle when the vacuum pump runs to remove the bulk of the ethylene oxide from the chamber, followed by the opening of a valve to admit filtered air into the sterilizer chamber, returning it to atmospheric pressure. |
| <b>GENERAL<br/>VENTILATION</b>  | Mechanical ventilation applied to a room or an area for the purposes of climate control and dilution of hazardous chemical concentrations to safe levels.  |
| <b>HOOD</b>                     | The point of entry into a local exhaust system.  |
| <b>ISOLATION ROOM</b>           | A separate room containing the sterilizer and the sterilizer loading area.   |

**LOADING AREA**            The area in front of the sterilizer and aerator; in some hospitals, the loading area is a separate room with limited access.

**LOCAL EXHAUST VENTILATION**    Mechanical ventilation applied at or close to the source of an emission, for the purpose of drawing clean, uncontaminated air past the worker, capturing the emission, collecting it in an exhaust hood, and removing it from the building.

**MECHANICAL ACCESS ROOM**        A room into which the mechanical equipment of the sterilizer and aerator are recessed, leaving the front of the equipment flush with the wall; also known as the recess room.

**NORMAL LOAD**                The materials sterilized by the hospital.

**PULSE-PURGE**                That part of the sterilizer cycle after evacuation/exhaust consisting of repeated cycles of operation of the vacuum pump followed by vacuum relief.

**RECESS ROOM**                The mechanical access room.

**RELIEF VALVE**                A device to vent the sterilizer in the event the pressure exceeds the chamber design pressure.

**TEST LOAD**                 A "standard" load used in this study consisting of lengths of latex tubing in a wrapper.