



**Control of
Asbestos Exposure
During
Brake Drum Service**



U.S. DEPARTMENT OF HEALTH AND HUMAN SERVICES • Public Health Service • Centers for Disease Control
National Institute for Occupational Safety and Health

CONTROL OF ASBESTOS EXPOSURE
DURING BRAKE DRUM SERVICE

John W. Sheehy, Ph.D., P.E., C.I.H.
Thomas G. Cooper
Dennis M. O'Brien, Ph.D., P.E., C.I.H.
James D. McGlothlin, Ph.D.
Phillip A. Froehlich

U. S. DEPARTMENT OF HEALTH AND HUMAN SERVICES
Public Health Service
Centers for Disease Control
National Institute for Occupational Safety and Health
Division of Physical Sciences and Engineering
Cincinnati, Ohio 45226

August 1989

DISCLAIMER

Mention of company names or products does not constitute endorsement by the National Institute for Occupational Safety and Health.

DHHS (NIOSH) Publication No. 89-121

For sale by the Superintendent of Documents, U.S. Government Printing Office, Washington, D.C. 20402

ABBREVIATIONS

CDC	Centers for Disease Control
cfm	Cubic feet per minute
CFR	Code of Federal Regulations
DHEW	Department of Health, Education, and Welfare
DHHS	Department of Health and Human Services
ECTB	Engineering Control Technology Branch
EDXA	Energy-dispersive X-ray analysis
EPA	Environmental Protection Agency
f/cc	Fibers per cubic centimeter
f/m ³	Fibers per cubic meter
HAM	Hand-held aerosol monitor
HEPA	High efficiency particulate air
LOD	Limit of detection
Lpm	Liters per minute
NIOSH	National Institute for Occupational Safety and Health
OSHA	Occupational Safety and Health Administration
PCM	Phase contrast microscopy
PEL	Permissible exposure limit
REL	Recommended exposure limit
SAED	Selected area electron diffraction
TEM	Transmission electron microscope or microscopy
TWA	Time-weighted average

ABSTRACT

Earlier studies of airborne asbestos exposures to mechanics during brake maintenance operations showed overexposure to asbestos fibers during brake servicing, especially brake assembly cleaning. Because an estimated 150,000 brake mechanics and garage workers in the U.S. are potentially exposed to asbestos, a known carcinogen, and the lack of information available on the effectiveness of available controls, an evaluation of these methods was initiated. Detailed field surveys were conducted at five facilities employing five methods for controlling exposure to asbestos during brake repair. These included the use of two commercial enclosure devices with ventilation provided by a HEPA filter-equipped vacuum, a HEPA filter-equipped vacuum alone, a brush with recirculating cleaning solution, and cleaning solvents in aerosol cans. These controls were evaluated while servicing brakes to automobiles, pickup trucks, vans, and vehicles with a 4-wheel rear axle. Detailed evaluations of these control measures involved a program consisting of traditional air sampling methods, incorporating phase contrast microscopy (PCM) and transmission electron microscopy (TEM), and real-time analysis of brake dust exposure. Personal and area air samples were collected during brake repair to each vehicle. The TEM results include asbestos fibers of all lengths.

The airborne asbestos concentrations experienced by auto mechanics while using various control methods were determined from the personal and source samples. Personal sample results for the brake mechanics show that concentrations using PCM analysis ranged from less than 0.004 to 0.016 f/cc. All exposures were below the NIOSH recommended exposure limit (REL) of 0.1 f/cc using PCM analysis. Analyses by TEM indicated the presence of asbestos fibers not detected by PCM, but at levels well below 0.1 f/cc for maintenance operations involving small to medium size vehicles. The highest measured exposures as determined by TEM were found for workers servicing heavy duty trucks. Fibers in the wheel drum bulk samples represented less than 1 percent of the brake dust, but were generally 60 to 100 percent chrysotile. Based on the results from this study, all the devices tested, in combination with the work practices used, controlled the mechanic's asbestos exposure during brake servicing to less than the OSHA PEL and the NIOSH REL. The personal exposures to asbestos determined in this study were much lower than those reported in the literature for brake service operations involving the use of compressed air and brush cleaning. Recommendations for improved work practices, as well as suggested modifications to the control systems, are presented.

CONTENTS

Disclaimer	ii
Abbreviations	iii
Abstract	iv
Acknowledgments	viii
1. Introduction	1
1.1. Historical Development of Friction Products for Vehicular Brakes	2
1.2. Requirements for Brake Linings	3
1.3. Brake Service Operations and Control Methods	4
1.3.1. History of Brake Lining Repair and Maintenance	4
1.3.2. Current Brake Repair Practices and Control Methods	5
2. Potential Health Hazards and Exposure Criteria	6
2.1. Toxic Effects	6
2.1.1. Asbestos	6
2.1.2. Solvents	7
2.2. Exposure Criteria	7
2.2.1. OSHA Permissible Exposure Limit	7
2.2.2. NIOSH Recommended Exposure Limit	7
3. Methodology	9
3.1. Overview	9
3.2. Site Selection	9
3.3. In-Depth Surveys	9
3.3.1. Air Sampling and Analysis	10
3.3.2. Ventilation	12
3.3.3. Ergonomic Evaluation of Brake Maintenance and Repair	12
3.3.4. Real-Time Sampling	12
4. Control Methods and Facility Sites Surveyed	14
4.1. Vacuum Enclosure A	14
4.1.1. Control Description	14
4.1.2. Facility Description	18
4.2. Vacuum Enclosure B	19
4.2.1. Control Description	19
4.2.2. Facility Description	22
4.3. Vacuum Only	24
4.3.1. Control Description	24
4.3.2. Facility Description	24
4.4. Wet Brush/Recycle	27
4.4.1. Control Description	27
4.4.2. Facility Description	29

4.5.	Aerosol Spray	29
4.5.1.	Control Description	29
4.5.2.	Facility Description	32
4.6.	Rudimentary Controls and No Controls	33
5.	Results	34
5.1.	Asbestos Concentrations as Determined by PCM	34
5.2.	Asbestos Concentrations as Determined by TEM	37
5.2.1.	Personal Sampling Results	37
5.2.2.	Source Sampling Results	37
5.2.3.	Background Sampling Results	40
5.2.4.	Outdoor Ambient Sampling Results	40
5.2.5.	Bulk and Settled Dust Samples	40
5.2.6.	Field Blanks	44
5.3.	Large Vehicles	44
5.4.	Real-Time Sampling Results	44
6.	Discussion	49
6.1.	Control Performance	49
6.1.1.	Comparison to Historical Data	49
6.1.2.	Comparison to No Controls	51
6.1.3.	Comparison to Indoor and Outdoor Ambient Levels	51
6.1.4.	Effect of Vehicle Type, Drum Size, and Number of Drum Brakes	52
6.2.	Control Method Design Strengths and Weaknesses	52
6.2.1.	Vacuum Enclosures	52
6.2.2.	Vacuum Only	54
6.2.3.	Wet Brush/Recycle	54
6.2.4.	Aerosol Spray	55
6.3.	Recommendations of Regulatory Agencies	55
6.3.1.	Occupational Safety and Health Administration	55
6.3.2.	U.S. Environmental Protection Agency	56
6.4.	Real-Time Sampling	57
6.5.	Work Practices and Hygiene	57
6.6.	Fiber Size and Potential Health Effects	59
7.	Conclusions/Recommendations	61
7.1.	Conclusions	61
7.2.	Recommendations	63
7.2.1.	Engineering Controls and Work Practices	63
7.2.2.	Training and Education	64
7.2.3.	Sanitation	65
7.2.4.	Protective Clothing and Respiratory Protection	65
8.	References	66

FIGURES

4-1.	Enclosure A glove box and filter assembly	17
4-2.	Layout of garage with enclosure A	20
4-3.	Vacuum enclosure B system	21
4-4.	Layout of garage with enclosure B	23
4-5.	Vacuum with HEPA filter	25
4-6.	Layout of garage with vacuum	26
4-7.	Wet brush/recycle system	28
4-8.	Layout of garage with wet brush/recycle	30
4-9.	Aerosol Sprayer	31
5-1.	PCM fiber concentrations	36
5-2.	Arithmetic vs geometric mean asbestos exposure (TEM)	39
5-3.	Personal vs background asbestos levels (TEM)	42
5-4.	Asbestos exposures: Large trucks vs smaller vehicles	46
6-1.	Fiber exposures by PCM	50
6-2.	Fiber size distribution for all personal samples	60

TABLES

4.1.	Facility Description	15
4-2.	Vehicle Description	16
5-1.	Personal Sample Fiber Concentrations by Control Method (PCM)	35
5-2.	Source Sample Fiber Concentrations (PCM)	35
5-3.	Personal Sample Asbestos Concentrations by Control Method (TEM)	38
5-4.	Source Sample Asbestos Concentrations (TEM)	38
5-5.	Asbestos Ambient Concentrations as Determined by TEM	41
5-6.	TEM Analysis of Bulk Brake and Settled Dust Samples	43
5-7.	Asbestos and Fiber Concentrations During Servicing Large Drum Brakes	45
5-8.	Average Relative Respirable Dust Levels (in millivolts)	48
Appendix.	Fiber Counts on Filter Blanks	70

ACKNOWLEDGMENTS

We thank the following individuals who assisted with the sampling surveys: Frank Godbey, Harold Van Wagenen, Michael Gressel, James Gideon, William Todd, Karen Lenihan, Paul Hentz, and Cliff Kohlmeyer, of NIOSH; and Tom Weems of PEI, Inc. We especially thank Eugenia Shtrom of PEI who performed the TEM microscopy and Data Chem for the PGM analysis. We appreciate the excellent cooperation of personnel from the Ohio Department of Transportation 8th District Garage; the U.S. Post Office Maintenance Facilities in Nashville, Tennessee, and Louisville, Kentucky; the Cincinnati Bell Telephone Company; and the Cincinnati Gas and Electric Company. In addition, we thank Mr. Vinay Kumar and Mr. Steve Shapiro of the U.S. Environmental Protection Agency, Washington, D.C., for their technical guidance and support in this study.

This study was supported under Interagency Agreement No. DW75931956-01 with the Chemical Engineering Branch, Office of Toxic Substances, U.S. Environmental Protection Agency.

1. INTRODUCTION

Under the Occupational Safety and Health Act of 1970, the National Institute for Occupational Safety and Health (NIOSH) has been given a number of responsibilities including the identification of occupational safety and health hazards, evaluation of these hazards, and recommendation of standards to regulatory agencies to control the hazards. Located in the Department of Health and Human Services (formerly DHEW), NIOSH conducts research separate from the standard setting and enforcement functions conducted by the Occupational Safety and Health Administration (OSHA) in the Department of Labor. An important area of NIOSH research deals with methods for controlling occupational exposure to potential chemical and physical hazards. The Engineering Control Technology Branch (ECTB) of the Division of Physical Sciences and Engineering has been given the lead within NIOSH to study the engineering aspects relevant to the control of these hazards in the workplace.

NIOSH has been instrumental in the development of recommendations for safeguarding workers' safety and health from exposure to occupational hazards. Since 1976, ECTB has conducted assessments of health hazard control technology on the basis of industry, common industrial process, or specific control techniques. The objective of each of these studies has been to document and evaluate control techniques and to determine their effectiveness in reducing potential health hazards in an industry or at specific processes. These data are used to create a greater awareness of the need for or availability of an effective system of hazard control measures.

This research effort involves a series of walk-through surveys of selected manufacturing plants or processes and an assessment of those that have been designed to effectively control exposure or minimize safety related hazards. Emphasis is placed on identifying concepts in design which can be transferred to other similar processes. Next, in-depth surveys are conducted to determine the control parameters and their effectiveness on preventing a health risk. The reports from these in-depth surveys are used as a basis for making control recommendations in NIOSH policy documents and preparing technical reports and journal articles on the effectiveness of designs and techniques for controlling hazards. This information is part of a data base available to health professionals, equipment manufacturers, and others to assist in the development of effective control measures in the workplace.

Asbestos is used in the manufacture of vehicular brake materials; however, because airborne asbestos exposure to workers has been associated with an increased risk for cancer, other materials have been substituted for asbestos in the fabrication of friction materials used in brakes. However, asbestos is

still a component in a majority of brakes and there is a potential for asbestos exposure during maintenance and replacement of brakes, especially on older model vehicles.

A research and control priority assessment of occupational carcinogens by Dubrow and Wegman⁽¹⁾ identified occupations with potentially high cancer risk by combining the results of 12 major occupational disease surveillance studies. On the basis of these results and analysis of other available epidemiologic, industrial hygiene, toxicologic, and employment data, recommendations were made concerning priorities for occupational cancer research and control. Their results pointed to asbestos as the number one priority requiring further investigation of methods to control exposure. "In this situation, where occupational disease surveillance studies point to a likely problem with a known carcinogenic agent, the priority should be placed on industrial hygiene investigations of asbestos exposure in the suspect occupations. If likely exposure is found, control measures should be developed and instituted."

There are frequent asbestos exposures during vehicle brake maintenance. From data contained in the National Occupational Hazard Survey, NIOSH estimates that a work force of at least 155,000 brake mechanics and garage workers in the U.S. are potentially exposed to asbestos.⁽²⁾ Because of the large number of workers potentially exposed, and the limited data on asbestos exposures associated with these occupations, a study was initiated to assess the effectiveness of controls used during the servicing of vehicular brakes. The vast majority of the affected workers are employed by small businesses that lack the resources necessary to evaluate these devices.

The objective of this study was to identify, evaluate, and document technology used to control exposure to asbestos in the vehicle brake drum service industry. This was accomplished by determining airborne concentrations of asbestos experienced by auto mechanics while using various control techniques during maintenance and replacement of drum brakes. The study focused primarily on vehicles with brake drum sizes of 12 inches or less. The maintenance of disc brakes was not evaluated in the study because the quantity of dust generated and retained by these systems is minimal and thus thought to represent a lesser potential for creating an exposure to asbestos.

1.1. HISTORICAL DEVELOPMENT OF FRICTION PRODUCTS FOR VEHICULAR BRAKES⁽³⁾

Early passenger cars were light and operated at low speeds. Brake materials included leather, impregnated cotton, wool, and felt. In 1903, woven asbestos friction materials were first marketed in the United States by the Keasbey and Mattison Company of Ambler, Pennsylvania.⁽⁴⁾ Because of the superior heat resistance and durability, woven asbestos brakes soon dominated the market and continued to be the predominant product used in automobiles until about 1930. They typically contained 70 percent or more wire-cored asbestos yarn impregnated with drying oils and bituminous material.

Molded brake linings were developed in the early 1920's and gained increasing use with the introduction of internal shoe brakes in 1927. By 1940, virtually all automobiles were equipped with molded brake linings, although the use of woven products continued in trucks, heavy equipment, and for specialized applications. The molded linings were usually cut to length by the manufacturer and mounted onto the brake shoes with rivets. Until the mid 1920's, brakes were only mounted on rear wheels; however, with the development of internal shoes, four wheel braking systems soon became standard.

As automobiles were manufactured for use at higher speeds, brake linings were improved in both quality and performance. Various new materials were introduced as fillers, binders, and friction modifiers. Bonded brake linings were developed in 1948 and soon accounted for approximately 40 percent of the original equipment brake market. They also rapidly dominated the replacement market because of the considerable savings in labor during installation. In 1965, the first disc brakes were introduced on American automobiles and by 1975, virtually all original equipment cars had front wheel brakes of this type. However, because of less stringent braking requirements and the difficulty of adapting mechanical parking brakes to the disc configuration, the rear wheel brakes on 95 percent of cars sold in early 1980's were of the drum variety.

1.2. REQUIREMENTS FOR BRAKE LININGS

A wide variety of ingredients are commonly used in the manufacture of automobile brake linings to achieve the desired friction properties.⁽⁵⁻⁸⁾ These include asbestos, organic binders, friction modifiers, fillers, and curing agents. Asbestos is used for fiber reinforcement, flexibility, and heat resistance. Chrysotile is used almost exclusively and comprises from 40 to 50 percent of the brake lining. Amosite, crocidolite, or other amphibole asbestos varieties are not used because they are too harsh and tend to score the brake drums.

The lining should be nonabrasive to the drum surface. In addition to causing rapid drum wear, abrasive linings score the drums which, in turn, exacerbates the wear of the lining. Brake drums are commonly made of cast iron and steel. Steel drums are more susceptible to scoring.

During braking, chemical and physical changes occur in the material at the braking surfaces. These changes may produce an increase (build-up) or a decrease (fade) in friction. Brakes with satisfactory linings fade slightly upon repeated applications, but return to their initial state upon cooling.⁽⁹⁾ Ideally, the desired frictional qualities should be maintained throughout the life of the lining material.

Low wear of the linings is desirable for economical and practical considerations; however, if the resistance is too low, excessive pedal pressure may be required. On the other hand, high wear resistance linings have a tendency to glaze. This can be overcome if the brake lining surface can be renewed. Pyrolysis of the organic binders and thermal decomposition of the

chrysotile fibers under braking conditions provide the necessary continual renewal of the lining surface.

Other necessary or desirable properties of brake linings include: physical strength, dimensional stability, quiet operation, and safe and nonoffensive degradation products. Of the properties desired in the linings, greatest attention is paid to build-up, fade, and recovery characteristics.

Various studies show that brake dust consists of 0.004 to 30 percent asbestos, by weight, with the vast majority of the samples containing less than 5 percent asbestos. (8,10-13) When these samples were analyzed by optical and electron microscopy, a majority of the asbestos fibers were less than 5 μm in length. One study showed 75 percent of asbestos fibers were less than 0.3 μm in length. (13,14) Another showed 80 percent of chrysotile fibers from brake drums were less than 0.4 μm long. (8)

1.3. BRAKE SERVICE OPERATIONS AND CONTROL METHODS

1.3.1. History of Brake Lining Repair and Maintenance (3)

The evolution of brake lining materials led to changes in work practices which affected brake mechanics' exposure to asbestos. From 1920 until about 1930, when braking was done through the use of external brake bands made from woven materials, the predominant exposure to asbestos was due to the cutting and fitting of the woven lining material. It is speculated that the airborne fiber concentrations during this period were considerably less than those which occurred later when machining of molded materials was common.

From 1927, when internal brake shoes with molded linings were developed, until 1948, when bonded brake linings were introduced, internal brake linings were attached to shoes using rivets. The lining material for use in the replacement market was supplied in large rolls or as segments pre-cut to appropriate size. Most of the pre-cut segments were drilled at the factory for rapid mounting on the shoes. In some circumstances, however, drilling for the rivets and bevelling were done by the mechanic installing them. The use of rolled linings required cutting the friction material to shape, drilling holes for rivets, and bevelling the edges appropriately. These practices contributed significantly to the asbestos exposure to workers. Even when shoes with drilled and bevelled linings were installed, the processes of punching out the rivets holding the old lining and riveting the new lining to the shoes gave rise to asbestos exposures.

With the introduction of bonded linings, the need for drilling, facing, or grinding operations during installation decreased significantly. However, for a short period of time in the mid 1950's when automobile brake shoes were first installed with a fixed anchor, some tapering was necessary on uniform thickness bonded linings to achieve a proper fit. Previously, the end of the shoe opposite to that of the hydraulic cylinder could be mechanically adjusted. Shortly thereafter, tapered bonded linings were available from the factory.

Subsequent to 1960, considerably fewer bevelling or grinding operations were performed by an automobile mechanic replacing brake linings.

During replacement of internal shoe brakes, a common practice was to remove the brake wear dust from the housing by compressed air or brushing. After 1970, because of increasing awareness of the hazards of asbestos and its presence in brake lining dust, some brake servicing facilities changed to work practices which included wet or dry brushing, wet wiping, or vacuuming.

In the 1930's and 1940's, most automobile shops were relatively small and most mechanics performed all automobile maintenance and repair activities. In recent years, however, there has been an increasing tendency towards specialization, and the establishment of shops for brake and front end work exclusively. Although asbestos exposures during brake work on an individual vehicle may be less than those of previous years, workers who perform brake repairs in these franchised high-volume shops are exposed for considerably longer periods of time.

1.3.2. Current Brake Repair Practices and Control Methods

Repair facilities, from small service stations to fleet garages, follow similar brake servicing procedures. A vehicle is driven into a repair stall or bay for a brake system examination; the wheels are elevated, removed, and the brake assembly is inspected. Loose dust is cleaned from the drums and brake assemblies by vacuuming, wet or dry wiping/brushing, blowing with compressed air, or a combination of these methods. At the time of this study, however, most brake servicing facilities used wet brushing, wet wiping, squirt-bottle wash-off, or high efficiency particulate air (HEPA) filtered vacuum cleaning systems. Parts are then replaced or repaired as needed and the brake system is reassembled and adjusted. Test driving the vehicle for proper fitting and adjustment is the final phase of the servicing operation. During these brake servicing operations, the brake repairman and other service personnel in the garage area are potentially exposed to asbestos dust at all times during and following the brake drum removal. If the normal dust buildup inside the drum and brake assembly is removed and disposed of in a controlled manner, these exposures can be minimal.

2. POTENTIAL HEALTH HAZARDS AND EXPOSURE CRITERIA

2.1. TOXIC EFFECTS

2.1.1. Asbestos

The potential health effects from the inhalation of chrysotile asbestos fibers include asbestosis, lung cancer, and mesothelioma.⁽¹⁵⁻¹⁹⁾ In a detailed examination of 90 New York City union motor vehicle maintenance workers with 10 or more years of shop work, 29 percent had decreased vital capacity.⁽¹⁸⁾ Many of the workers examined showed signs consistent with asbestosis, with observed changes noted in chest X-rays and indications of restrictive respiratory disease. The prevalence of these changes was significantly higher 20 years from the onset of auto work; a result frequently experienced by other workers who have had occupational exposure to asbestos.⁽¹⁹⁾

Chrysotile asbestos fibers exist in automobile brake dust in various states of deformation due to the chemical degradation at the high temperatures encountered during use. Unlike chrysotile, the health effects from exposure to forsterite (a deformation product of chrysotile), or to transition series fibers (chrysotile/forsterite) with altered crystalline structures are not well documented. In studies by Davis and Coniam⁽²⁰⁾ and Koshi,⁽²¹⁾ in which fibers of chrysotile, chrysotile/forsterite, and forsterite were injected into the pleural and peritoneal cavities of mice, the results suggested varying degrees of toxic effects. Fiber implantation animal studies conducted by Pott et. al.^(22,23) and Davis⁽²⁴⁾ suggest that the morphology and size of a fiber, regardless of fiber type, are responsible for its carcinogenicity. Likewise, the results of mineral fibers implanted into the pleurae of rats reported by Stanton et. al.⁽²⁵⁾ suggest that fibers less than 1.5 μm in diameter and greater than 8 μm in length pose the greatest risk in producing pleural sarcomas. These studies suggest that the physical morphology (size, dimensions) and, to a lesser degree, the chemical and surface characteristics of a fiber are the determining factors for inducing a biological effect. The precise fiber dimensional characteristics required for these observed pathologic responses have been difficult to determine experimentally because of the difficulties encountered in producing inoculants containing fibers of specific dimensions.

Because of the adverse health effects observed in auto repair workers and the lack of a clearly identifiable no-effect concentration for asbestos, it is necessary to minimize exposure to brake dust.

2.1.2. Solvents

Solvents observed to be used at various facilities during this study were 1,1,1-trichloroethane (commonly known as methyl chloroform) and Greasoff®.

1,1,1-Trichloroethane is irritating to the eyes on contact. Exposure to the vapors may result in adverse effects on the central nervous system. Symptoms of overexposure include dizziness, incoordination, drowsiness, and increased reaction time. Unconsciousness and death can occur from exposure to excessive concentrations. (26)

Greasoff® No. 19 contains less than 5 percent by weight sodium metasilicate and less than 5 percent by weight 2-butoxy ethanol (also known as ethylene glycol monobutyl ether or butyl cellosolve). Sodium metasilicate, a highly alkaline compound (pH 12.4), is severely irritating to the eyes, skin, and mucus membranes. (27) 2-Butoxy ethanol can be absorbed by the skin and is a hemolytic agent and will irritate the eyes and upper respiratory tract. (28)

This study was limited to the evaluation of the potential for exposure to asbestos; no determinations of airborne solvent concentrations were made.

2.2. EXPOSURE CRITERIA

The two sources of occupational exposure criteria for asbestos considered in this study are: (1) the NIOSH Recommended Exposure Limit (REL), and (2) the Department of Labor OSHA Permissible Exposure Limit (PEL).

2.2.1. OSHA Permissible Exposure Limit

On June 20, 1986, OSHA (29) issued a revised PEL, which reduced the allowable asbestos fiber exposure level observed by phase contrast microscopy (PCM) from 2.0 to 0.2 f/cc, as an 8-hour time-weighted average (TWA) exposure. It also set an action level of 0.1 f/cc that triggers worker training, medical monitoring, and other requirements. The new PEL does not set a ceiling or short-term exposure limit. NIOSH recommends that worker exposure to asbestos be reduced to the lowest feasible limit, due to the carcinogenic nature of this substance. On September 14, 1988, OSHA published a short-term exposure limit for asbestos of 1 f/cc for a 30-minute period. (30)

2.2.2. NIOSH Recommended Exposure Limit

The NIOSH REL for asbestos is 0.1 fibers greater than 5 μm in length per cubic centimeter (f/cc) and was established based on the analytical limitations of using phase contrast microscopy. (31) NIOSH reaffirmed its position on asbestos at the OSHA proposed rulemaking hearings for asbestos in June 1984, (32) summarized as follows:

The carcinogenic potential of asbestos is no longer in doubt; however, there is some uncertainty about the toxicological and morphological properties which determine the carcinogenic potency of various fibers. On

the basis of available information, there is no scientific basis for differentiating between asbestos fiber types for regulatory purposes. Data available to date provide no evidence for the existence of a threshold level. Virtually all levels of asbestos exposure studied to date demonstrated an excess of asbestos-related disease.

Both asbestos and smoking are independently capable of increasing the risk of lung cancer mortality. When exposure to both occurs, the combined effect, with respect to lung cancer, appears to be multiplicative rather than additive. From the evidence presented, we may conclude that asbestos is a carcinogen capable of causing lung cancer and mesothelioma, independent of smoking.

NIOSH has recommended that asbestos be controlled to the lowest detectable limit. Any standard, no matter how low the concentration, will not ensure absolute protection for all workers from developing cancer as a result of their occupational exposure. However, lower exposures carry lower risk of disease.

Because the only widely available method, NIOSH Method 7400,⁽³³⁾ is able to achieve (intralaboratory) accuracy of 12.8 percent relative standard deviation at an exposure limit of 0.1 f/cc (100,000 f/m³) in a 400 liter sample, NIOSH and others have recommended an exposure limit (REL) of 0.1 f/cc for asbestos based on 8-hour time-weighted average concentrations with peak concentration not exceeding 0.5 f/cc.⁽³¹⁾ The use of electron microscopy is recommended in the event of process or product modification, in mixed fiber exposures, or when there are other reasons for characterization of fiber type and morphology.

As stated above, the occupational exposure criteria (the NIOSH REL and the OSHA PEL) are based on the PCM analytical method. This method has inherent limitations based on the physics of the optical microscope and upon the ability of the microscopist to reliably discriminate fiber dimensions in a complex sample matrix. The minimum diameter routinely observed is on the order of 0.5 μm . The NIOSH 7400 method stipulates that only fibers longer than 5 μm be counted with a length to width ratio equal to or greater than either 3:1 ("A" rules) or 5:1 ("B" rules). (The "A" and "B" rules have other minor differences.) The "A" rules use the aspect ratio specified in the current OSHA PEL and NIOSH REL. In the present study, transmission electron microscopy (TEM) was used to determine the actual dimensions of all fibers counted and to differentiate fibers by length to width ratios. A coarse analysis of our data by fiber aspect ratios indicates that fiber counts would differ by less than 8 percent between the use of 3:1 or 5:1 aspect ratios.

Another concern is that asbestos fibrillae as small as 0.02 μm in diameter and less than 1 μm in length are visible only with electron microscopy. These fibrillae constitute a significant and variable proportion of the total fibers present in brake dust. Thus PCM, in counting only optically visible particles, may not be a good indicator of the total fibers present. Controversy over the health effect of small fibers (and thus what sizes of fibers should be counted) adds further ambiguity.

3. METHODOLOGY

3.1. OVERVIEW

This study was conducted to identify, evaluate, and document technology used to control exposure to asbestos in the vehicle brake drum service industry. During the first phase of this project, walk-through surveys of 12 work sites were performed to observe the work practices and control methods in use and to select systems which appeared to be effective for minimizing exposure to asbestos for detailed study. Selection of sites was made based on the type of control technique(s) being used at that site, and the type and quantity of vehicles available for brake repair. In the second phase, detailed evaluations were performed at five of these sites. A brake service operation using rudimentary control and one using no control were also sampled. A site using compressed air and dry brushing could not be found; therefore, historical exposure data were used as a base line.

The evaluations included both extensive monitoring of airborne asbestos fibers and the documentation of work practices, and were conducted at locations servicing different types of vehicles and employing a variety of work practices. The study focused on the state-of-the-art control devices and their acceptance among mechanics performing brake service.

3.2. SITE SELECTION

The walk-through surveys were conducted at facilities employing a variety of control methods. Sites were selected primarily from fleet garages so that a sufficient number of brake inspections could be observed, and to control for variables such as vehicle type, use, and maintenance practice.

During the walk-through surveys, the effectiveness of the brake drum service control methods for preventing asbestos exposures were visually assessed. These included: Ammco Brake Assembly Washer, Klear-flo Brake Washer Assembly, Clayton Brake Cleaning Equipment, Hako Minuteman Asbestos Brake Drum Vacuum System, Nilfisk Asbesto-Clene System, Per-Lux Brake Assembly Cleaner, a squirt bottle solvent wet method, a squirt bottle method with vacuuming, a steam jenny with vacuum, a vacuum with wet washing, and HEPA filtered vacuuming only.

3.3. IN-DEPTH SURVEYS

A team of three to six researchers consisting of engineers, industrial hygienists, and engineering technicians conducted each in-depth survey. The specific control method evaluated was that used in the facility studied. Other sizes or models of control devices produced by the same manufacturer and

similar devices made by other companies may be more or less effective; however, limited resources precluded an evaluation of more than one model and size. The methods used for controlling exposure were evaluated under the conditions of normal use, i.e., the control hardware or work practices were not altered for this study. For each control method, six to eleven vehicles were evaluated.

3.3.1. Air Sampling and Analysis

The NIOSH Occupational Exposure Sampling Strategy Manual⁽³⁴⁾ suggests that the most reasonable sampling strategy, for the most efficient use of sampling resources, is to sample the employee presumed to have the highest exposure risk. If there are a number of work operations as a result of different processes where there may be exposed employees, then a maximum risk employee should be selected for each operation. Samples taken for comparison with ceiling standards are best taken in a nonrandom fashion. That is, all available knowledge relating to the area, individual, and process being sampled should be utilized to obtain samples during periods of maximum concentrations of the substance.

Two personal air samples for asbestos were collected side-by-side in the breathing zone of each worker for the duration of a single brake job, or for 2 hours, whichever was longer. Samples were collected on 25 mm diameter, 0.8 μm pore size, cellulose ester, membrane filters at a flow rate of 2.5 to 3.0 Lpm using a personal sampling pump. The minimum volume collected (300 liters) allowed a limit of detection (LOD) of approximately 0.004 f/cc by Phase Contrast Microscopy (PCM) analysis. (The LOD for one set of personal samples collected for 1.2 hours was 0.008 f/cc.)

Area air samples for asbestos also were collected on 25 mm diameter, 0.8 μm pore size, cellulose ester filters. Two area samples per vehicle (source samples) were collected; one near the fender and the other under the axle at a flow rate of approximately 7.0 Lpm using rotary vane vacuum pumps for the duration of a brake job, or 2 hours, whichever was longer. The source samples were used to determine if fibers escaped into the working environment during the repair activities. The minimum volume collected (840 liters) allowed a LOD of 0.002 f/cc by PCM.

Two additional area samples (background samples) were collected in the garage, at least 10 feet from brake repair activities, at flow rates of 7.0 to 10 Lpm for each 4-hour sample period. These background samples were used to determine the effects of general shop cleanliness and overall effectiveness of the dust control procedures. The minimum volume collected (1,000 liters) allowed a LOD of 0.002 f/cc by PCM.

Samples were also collected out-of-doors (ambient concentrations) to determine environmental concentrations of asbestos. These ambient samples were collected at a flow rate of approximately 3.0 Lpm using personal sampling pumps for up to 8 hours. The minimum volume collected (800 liters) allowed a LOD of 0.002 f/cc by PCM.

All filter air samples were analyzed by PCM using NIOSH Method 7400.⁽³³⁾ In addition to PCM analysis, approximately 80 percent of these samples were analyzed by Transmission Electron Microscopy (TEM).⁽³⁵⁾ To facilitate analysis by PCM and TEM on the same samples, the direct transfer method of sample preparation described by Burdett and Rood⁽³⁶⁾ was used (modified by the omission of the filter etching*). TEM analysis was performed to identify asbestos fibers and determine concentrations for fibers too small to be detected by optical microscopy analysis. (In our study, almost all of the fibers in the brake dust were too small to be measured optically.)

For PCM analysis, all fibers with a 5:1 (or greater) length to width aspect ratio were counted using Method 7400-B. (A small number of samples were analyzed by PCM using Method 7400-A counting rules because the routine laboratory procedure for Method 7400 was changed to "A" counting rules before these samples were analyzed.) While the OSHA PEL and the NIOSH REL are expressed in terms of fibers having a 3:1 (or greater) aspect ratio, the difference in counting rules has little practical significance in the case of brake dust. Few fibers were identified in this study with aspect ratios between 3:1 and 5:1. (Data on fiber aspect ratios is presented in Section 5.) TEM analysis was performed using NIOSH Method 7402.⁽³⁵⁾ Fibers were identified by morphology, selected area electron diffraction (SAED), and energy-dispersive X-ray analysis (EDXA). Fibers were classified in one of four categories: chrysotile, amphibole, ambiguous, and no identification. SAED patterns were observed for all fibers.⁽³⁷⁾ Fibers were also identified by asbestos structure (fibers, bundles, clusters, and matrices) and sized by length and width. All fibers with a 3:1 (or greater) aspect ratio were counted using TEM. The analysis was performed using a magnification of 17,600X (grid area of 0.000081 cm²) and counting either a minimum of 10 grid openings or 100 fibers, whichever came first. The limit of resolution was approximately 0.06 μm , thus the minimum fiber length that could be measured was 3 times the limit of resolution, or about 0.2 μm . One or two field blanks were prepared for each vehicle sampled and submitted for PCM and TEM analysis. The results on both PCM and TEM were obtained by a contract from DataChem, Cincinnati, Ohio. The analyses were performed in NIOSH laboratories with NIOSH instrumentation and oversight. Analyses were performed according to contract specifications for both calibration and quality control which required the contractor to follow all procedures in NIOSH methods 7400⁽³³⁾ and 7402⁽³⁵⁾ for PCM and TEM, respectively. Specific quality control measures include submission and laboratory analysis of field blanks. Analysis of blind and double-blind quality control samples, and cross-checking of asbestos microscopic analysis by a NIOSH analyst who participates in the Proficiency Analytical Testing (PAT) program. In conducting their oversight functions, NIOSH laboratory managers adhere to the Division of Physical Sciences and Engineering Quality Control Manual.⁽³⁸⁾

* Six samples, etched and recounted by TEM, showed no change in fiber count.

A bulk brake dust sample from each vehicle and a settled dust sample from each repair facility were collected and analyzed for asbestos by TEM. The percentage of asbestos in the bulk samples was qualitatively established by estimating the ratio of the number of asbestos fibers to dust particles. Fibers were identified as asbestos using morphology, SAED analysis, and EDX analysis; the length and diameter of asbestos and other fibers were measured, and the percentage of asbestos of the total fibers present was quantitated.

3.3.2. Ventilation

Kurz Model No. 480 and TSI Model No. 1630 air velocity meters were used to measure air velocities to determine flow rates and directions in the garages. Smoke tubes were used to assist in the observation of general airflow patterns. Design airflow rates were obtained from the companies at several facilities. Air temperature, humidity, and wind conditions were determined using an aspirated psychrometer and velocity meters.

3.3.3. Ergonomic Evaluation of Brake Maintenance and Repair

For several of the control methods evaluated in this study, an ergonomic evaluation was conducted on workers performing brake maintenance and repair to determine if specific work practices contributed to the worker's exposure to asbestos. Each worker was videotaped during routine brake inspection and brake replacement tasks. Work cycle times and work analyses were performed from videotapes in the laboratory. Cycle times were taken with the video tapes running at normal speed; work analyses were conducted at both normal speed and by "stop-action" techniques. Work analysis included breaking the job into general tasks which could be correlated with relative airborne dust concentrations during brake inspection and replacement. Work tasks which could cause personal exposure to brake dust were identified.

3.3.4. Real-Time Sampling

The entire brake maintenance operation was recorded on videotape. A Hand-held Aerosol Monitor (HAM) from PPM, Inc., and an Apple II+ computer were used to measure and record the dust concentrations during most of the brake studies. The electro-optical system of the HAM generates a millivolt signal proportional to the relative respirable dust concentration. Before each brake job, the HAM was calibrated and zeroed, and the clocks in the computer and video camera were synchronized. Either DuPont P-4000 or MSA Model G pumps were connected by tubing to the HAM, which in turn was connected by a 25-foot electrical lead to the computer programmed to receive the data. The brake mechanic wore the HAM in his breathing zone while performing the brake maintenance. Data was recorded at 3-second intervals. The computer converted the output signal from the HAM to relative dust concentrations and stored the data on a floppy disk.

Using a spread sheet program (Lotus 1-2-3), a real-time plot of the relative dust concentrations was made. By identifying the various activities during brake maintenance (wheel removal, brake drum removal, cleaning, brake parts removal, brake parts and brake drum reinstallation, and wheel remounting)

average dust concentrations during each of these activities can be compared. The peaks from the plot delineate work activities which produce elevated dust concentrations. Also, the average dust levels can be compared between the various control methods used. The HAM is not specific for asbestos; however, asbestos fibers are a component of the brake dust, and therefore, the HAM can be a useful real-time monitor for the control of asbestos-laden dust.

4. CONTROL METHODS AND FACILITY SITES SURVEYED

In this study, five methods for controlling exposure to asbestos during brake repair were evaluated. These included: two enclosure devices with ventilation provided by a HEPA filter-equipped vacuum, a HEPA filter-equipped vacuum cleaner with no enclosure, a wet brush/recycle system which recirculated the cleaning solution, and an aerosol spray to wet and flush away the dust. In addition, one brake repair that used no control measures and another that used minimal controls were studied.

Each control method was evaluated at a different facility. This introduced many uncontrolled variables such as building layout, traffic pattern, and ventilation system. Also, the types of vehicles and wheel sizes were not identical among the control methods tested. The description of the control device is followed by information about the facility in which it was observed and the vehicles serviced. This information is summarized in Tables 4-1 and 4-2.

4.1. VACUUM ENCLOSURE A*

4.1.1. Control Description

This engineering control consists of a glove box for completely enclosing the brake assembly for brake drums up to 20 inches in diameter after the wheel has been removed. Figure 4-1 shows the glove box enclosure and the vacuum pump/filter assembly unit. The front of the glove box enclosure is constructed of clear Lexan® plastic and the back is comprised of flexible overlapping neoprene fabric strips. These allow the brake assembly to be easily inserted into the enclosure and also provide an essentially tight seal around the axle. Two long gloves are sealed into the front face of the enclosure and extend inwardly. These flexible gloves permit the mechanic to insert his hands and arms up to and sometimes past the elbows to operate a conventional compressed air gun, a vacuum line with brush attachment, a hammer and/or mallet, a separate brush, and other tools within the enclosure to clean the linings, pads, and other elements of the brake system. The enclosure is mounted to a base and can be rolled to its destination. Four corner frame posts support the enclosure and allow easy adjustment to a convenient level for servicing a vehicle on a lift rack.

* Pro-Line® BCE 2500, Clayton Associates, Inc., Farmingdale, NJ.

Table 4-1

Facility Description

Control	Work Bays (Number)	Brake Maintenance Area (sq. ft.)	Constructed (Year)	Ventilation During Survey	Brakes Serviced per Month	Mechanics (Number)	Outside Weather /Indoor Temp. (° F)
Vacuum Enclosure A	11	13,200	1970	Natural; Dilution	25-30	6	Mild, 70-85
Vacuum Enclosure B	11	10,100	1977	Mechanical; Dilution	28-36	11	Cool, 65-70
Vacuum Only	1	22,400	1950's	Natural and Mechanical; Dilution	7	2	Cool-Cold 50-65
Wet Brush/Recycle	14	7,100	1979	Natural; Dilution	25	10	Mild 65-75
Aerosol Spray	3-10	>1,000 <10,000	1940's to 1970's	Natural and Mechanical; Dilution	30-35	5-10	Mild 65-75

Table 4-2
Vehicle Description

Control	Type*	Number	Model Year	Brake Drum Diameter (inches)	Drums/Vehicle Serviced	Transmission
Vacuum Enclosure A	A	2	1979	9-10	2 Rear	Auto
	P	5	1977-85	10	2 Rear	Auto
	V	1	1983	11	2 Rear	Auto
	T	1	1977	17	2 Front	Manual
Vacuum Enclosure B	A	1	1979	11	2 Rear	Auto
	J	8	1974-83	9-11	4 Front/Rear	Auto
	V	2	1977-84	11-14	2 Rear	Auto
Vacuum Only	A	2	1977-82	9-10	2 Rear	Manual
	V	2	1977-79	11-14	2 Rear	Auto
Wet Brush/Recycle	J	10	1973-81	9-11	4 Front/Rear	Auto
Aerosol Spray	A	1	1980	10	2-Rear	Auto
	P	2	1983	9-11	2-Rear	Auto
	V	2	1982-83	11-12	2-Rear	Auto
	TT	1	1981	16.5	2-Rear	Auto

* A = Automobile, 1 to 2 tons curb weight
 J = Jeep 1.5 tons curb weight
 P = Pickup Truck 1/2 and 3/4 ton size
 V = Van 3 to 5 tons curb weight
 T = Truck Over 10 tons empty weight
 TT = Truck with tandem rear wheels, 13 tons empty weight

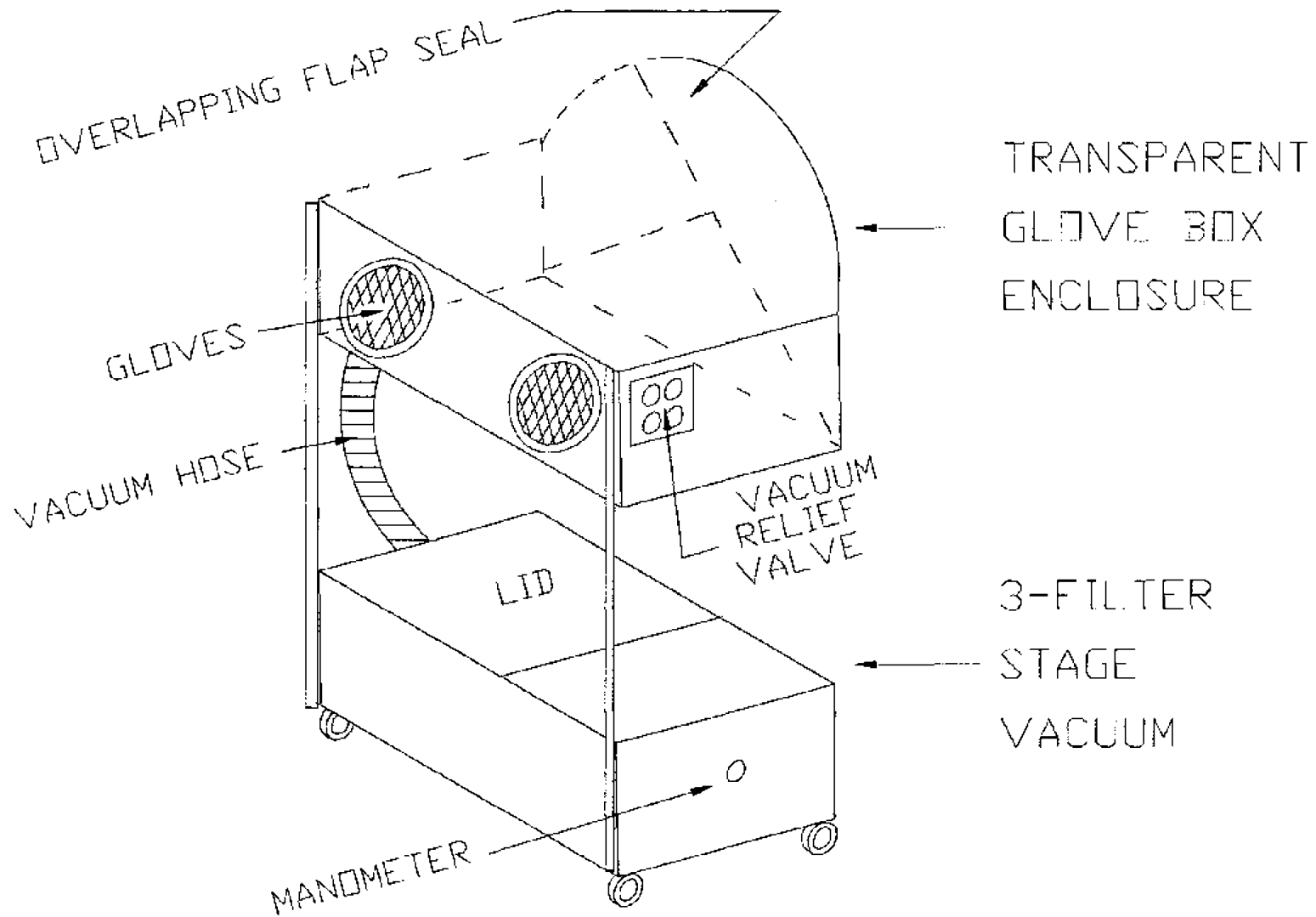

Figure 4-1. Enclosure A glove box and filter assembly.

The enclosure is connected to a vacuum pump with a three-stage filter assembly by a flexible hose. The first filter stage is a bag similar to a conventional home vacuum cleaner bag. The second stage, a 12-inch square prefilter, is similar to home hot air furnace filters. The third stage is a HEPA filter rated as removing 99.999 percent of particles greater than 0.12 μm in diameter.⁽¹⁴⁾ All filters are commercial items. The filter life is dependent on the amount of use and the total collection.

Brake servicing, using this vacuum enclosure, is accomplished in the following manner: After the vehicle is raised and the wheel is removed, the vacuum enclosure unit is rolled in front of the wheel. Tools and auxiliary items are placed within the enclosure. The vacuum pump is started and the unit is moved forward so the enclosure completely envelops the brake assembly (the rear, four-way flap tightly wraps around the axle). The drum is loosened using the gloves and either a hammer or mallet, then removed and set aside face up within the enclosure. The loose dust is vacuumed from the inside of the wheel drum, the surface of the brake shoes, and assembly. Dust adhering to the brake assembly is brushed and blown off with compressed air. The dust cloud generated within the enclosure is dissipated as the vacuum pump draws clean air through an inlet valve on the side of the enclosure and exhausts the contaminated air through the dust filters. The drum, shoes, and parts of the assembly are again vacuumed, as well as the inside surfaces of the enclosure. This procedure takes up to 5 minutes. After cleaning, the vacuum enclosure unit is removed from the brake assembly and the brake maintenance is completed.

An important operation not observed during the survey is the removal and replacement of the filters in the vacuum units. Normally, the first stage bag filter is replaced when the bag is about half full; at this point, the pressure indicated by the vacuum gauge on the unit is about 4 inches of water. For a production rate of 10 brake inspections per week, the second stage prefilter is replaced in about 3 to 12 months and the third stage HEPA filter is replaced in about 3 to 5 years. The HEPA filter requires careful installation to prevent bypass leakage. The manufacturer of this unit has introduced an exchange service whereby a dirty assembly returned to the manufacturer's plant will be immediately replaced with a new HEPA assembly.

The facility has employed this control device to reduce occupational exposure during brake inspection, repair, and brake lining replacement of all motor vehicles since early 1986. The mechanics thought the vacuum enclosure did a good job of containing and collecting brake dust when employed on cars and light pickup trucks. They thought that the unit was bulkier than necessary for light vehicles. The brake assemblies of large trucks and/or specialty units equipped with double wheel assemblies are different and much heavier than for light vehicles, however, and the workers did not consider this particular model to be as effective with the heavier vehicles.

4.1.2. Facility Description

This state government vehicle maintenance facility, completed in 1970, services 180 large trucks, 250 pickup trucks, 90 passenger cars, 25 vans, 25 loaders,

and other specialized road maintenance units (Figure 4-2). Repair work includes brake work, general maintenance, and engine overhauls and requires a substantial amount of specialized auxiliary equipment. The light vehicle area is separated from the heavy equipment repair section by a double row of lighted work benches and mechanic workstations. Overhead hoists are mounted in both garage areas for raising and moving the vehicles. Operations are conducted on a one-shift basis from 7:30 a.m. to 4:00 p.m. by 11 veteran mechanics, 2 body men, and 3 welders. Most of the approximately 300 to 500 annual brake jobs are performed by 5 to 6 mechanics.

The garage is situated so that prevailing wind currents provide natural ventilation through open doors during the warm months of the year. Fumes from vehicle engine testing are removed by means of flexible hoses fitted over exhaust system pipes. The hoses are connected to exhaust fans which discharge outside the building roof. The vehicle repair areas are exhausted by five 3,100 cfm roof fans. Four exhaust grilles (mounted approximately 18 inches above floor level) are connected to four roof-mounted fans of about 3,000 cfm capacity each. A 12,000 cfm direct-fired make-up air heating unit is interlocked to provide additional heat when any of the fans are operating.

Brake maintenance on nine vehicles -- two automobiles, one passenger van, five half-ton pickup trucks, and one large dump (salt) truck -- was evaluated using this vacuum enclosure control. The vehicles ranged in model year from 1977 to 1985 and the vehicle mileage ranged from 16,000 to 106,000.

4.2. VACUUM ENCLOSURE B*

4.2.1. Control Description

This control device consists of a 17.5-inch diameter steel cylinder, 16 inches long, equipped with a single rubber glove and a quick-connect fitting for an air hose (Figure 4-3). A compressed air cleaning nozzle is located inside the cylinder. One end of the cylinder is partially closed by an iris-type rubber flap connected by a cloth covered elastic band so that a 6-inch diameter opening remains. A plastic window is provided in the other end to observe the cleaning operation. The cylinder is mounted on a rolling stand. The height is adjustable and secured by a thumbscrew. The cylinder is connected to a HEPA filter-equipped vacuum cleaner. With the enclosure on a vehicle wheel and the vacuum on, this unit was observed to produce a face velocity of 150 to 200 fpm (approximately 30 to 40 cfm) at the seal opening around the axle of the vehicle. The vacuum cleaner may be easily disconnected from the cylinder enclosure to function independently as a cleaning device.

The vacuum cleaner has a set of four filters consisting of a first stage filter (a 6 mil polyethylene liner bag), a microfilter, a main filter, and a HEPA filter (rated at 99.97 percent removal of 0.3 μm diameter dust).⁽³⁹⁾ All but the main filter are replaced about twice a year. The main filter can be

* Nilfisk Asbesto-Clene® 500 System, Nilfisk of America, Inc., Malvern, PA.

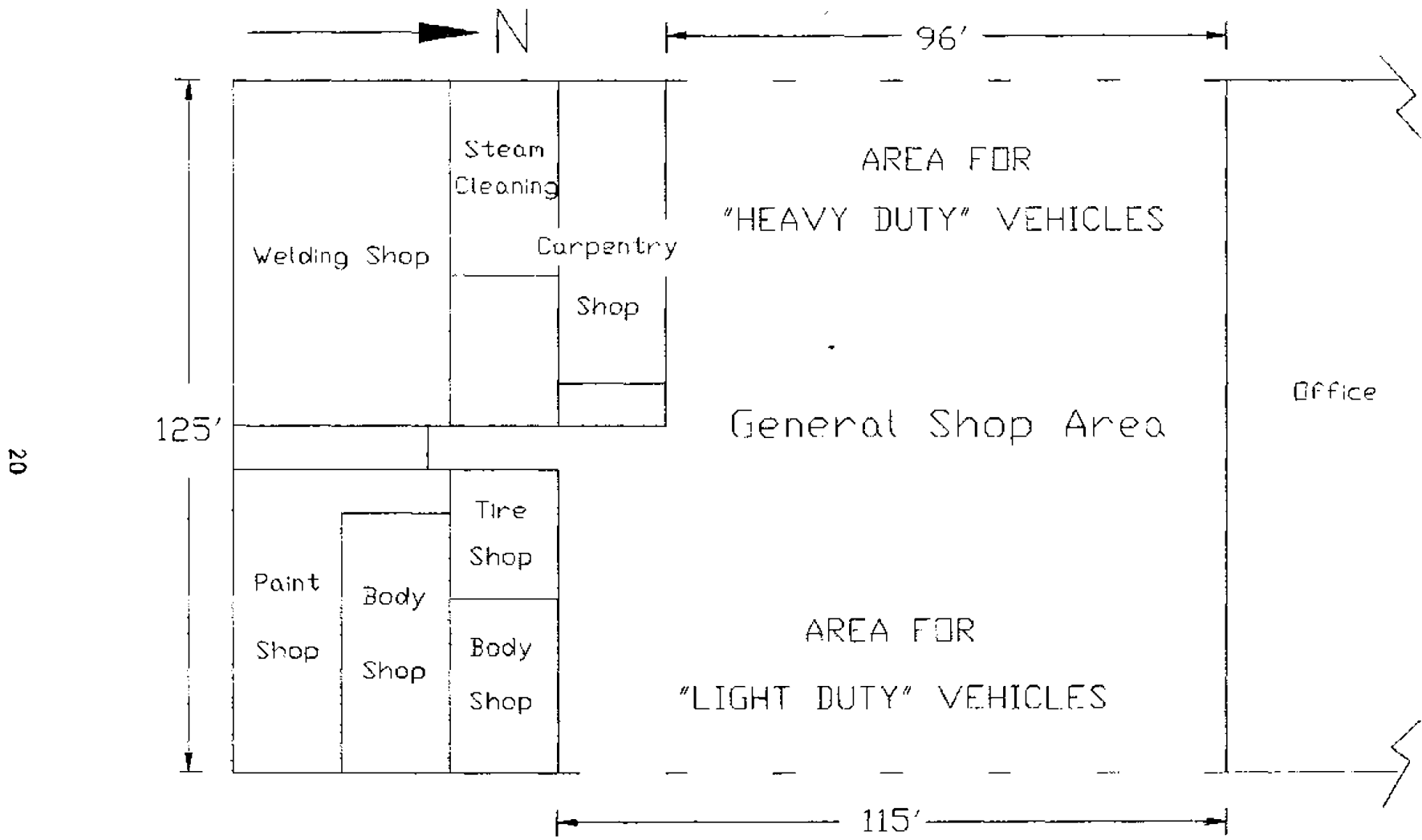

Figure 4-2. Layout of garage with enclosure A.

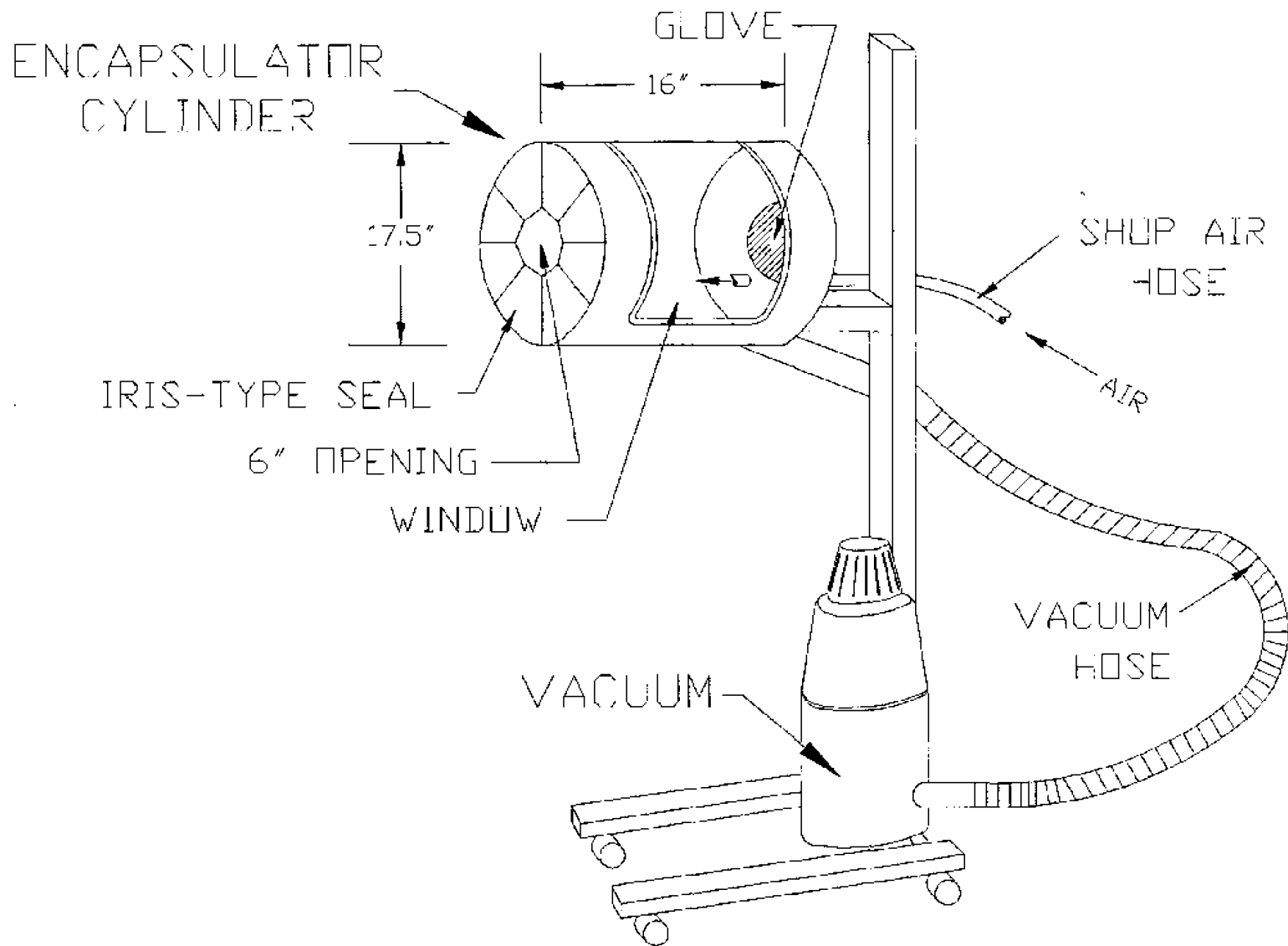

Figure 4-3. Vacuum enclosure B system.

purged and should last 20 years. At this facility, the contaminated filters are placed in a 5-gallon metal container which is filled to capacity with concrete and then disposed of as ordinary waste.

The following general brake cleaning procedure is used at this facility. The vehicle is driven onto the lift and raised 3 to 4 feet. The lug bolts are unscrewed and the wheel and brake drum are removed. The vacuum enclosure is installed over the backing plate of the wheel and dust on the brake components is blown off with compressed air. After the enclosure is removed, the inside surfaces are vacuum cleaned. The brake drum is also vacuumed. A supervisor inspects the brake components; if the brakes need replacing, the new shoes or components are installed, otherwise the drum and wheel are reassembled.

If previous maintenance on a vehicle occurred within 1,000 to 1,500 miles, two wheels are pulled and the brakes inspected. If the vehicle has been driven more than 1,500 miles since the last maintenance, all four wheels are inspected. This facility began replacement of asbestos brake linings with nonasbestos type materials in July 1986, several months before our survey. Nine of the eleven vehicles evaluated had asbestos type brake shoes.

4.2.2. Facility Description

This postal maintenance facility, constructed in 1977, is located in an industrial park in a building 158 feet long and 81 feet wide (Figure 4-4). The repair area, body shop, and paint shop occupy a high bay area of approximately 10,000 square feet. The main shop area contains twelve bays.

Under-floor vents and ceiling hoses, rated at 300 cfm each, are used to exhaust engine fumes through a single, centrifugal fan suspended from the roof. This system, operated on an as-needed basis to control vehicle exhaust, was in use during this survey. Two centrifugal fans suspended from the ceiling have inlets located near the floor, exhaust air at a rate of 4,960 cfm each through the shop roof, and are operated on an as-needed basis. They provide about 3 air changes per hour when operating; however, they were not observed to be used during this survey. About 6,600 cfm of heated make-up air is provided through a central overhead plenum with six outlets.

The facility is open from 6:00 a.m. to 6:00 p.m. Eleven mechanics work overlapping 8-hour shifts; all perform brake service. About 28 to 36 brake inspections/replacements are conducted each week.

Evaluations were made while brake service using enclosure B was performed on eight Jeeps, one automobile, and two vans. These vehicles had 9-, 11-, and 14-inch diameter brake drums. The model year of the vehicles ranged from 1974 to 1984 and the mileage ranged from 16,000 to 85,000 miles.

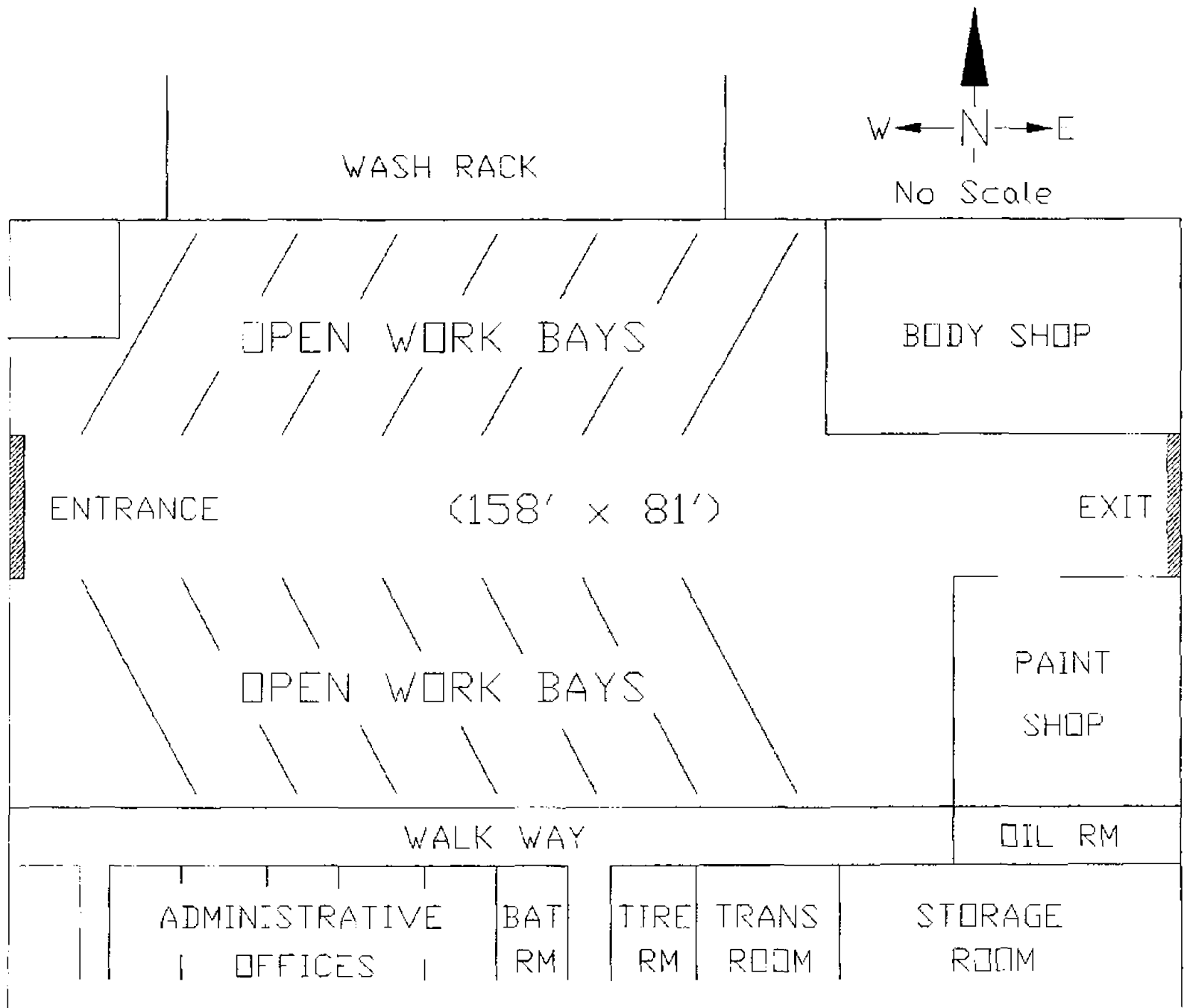

Figure 4-4. Layout of garage with enclosure B.

4.3. VACUUM ONLY*

4.3.1. Control Description

This HEPA filter equipped vacuum has been in use since about 1978. It consists of a dust removal hose connected to a three-stage HEPA filtered vacuum assembly (Figure 4-5). Coarse particles are separated by centrifugal action in the bottom area. Finer particles are collected by a main filter followed by a micro filter. Finally, a HEPA filter is used to remove the very fine dust (99.97 percent removal of 0.3 μm dust).⁽³⁹⁾

The vacuum unit is used during all brake inspection, repair, and brake lining replacement work. In the brake cleaning procedure, vacuuming is done after the hubcap, wheel, and drum are removed. Loose dust is vacuumed from inside the drum and from around the brake assembly. After disassembly, small parts (springs, screws, etc.) are generally vacuumed. No blowing with compressed air or wet methods are used. No special attachments are used with the vacuum hose. Air is drawn into the 1.25 -inch diameter nozzle at about 95 feet per second (50 cfm). After cleaning, the brake is inspected and then either reinstalled or repaired.

An infrequent operation not observed during this in-depth plant survey is the removal and replacement of the filters from the vacuum units. The filters are changed at about the same frequency as described for vacuum enclosure B units.

4.3.2. Facility Description

This is one of several fleet garages operated by a privately owned utility. Eighty-five assorted specialized vehicles are based here. Routine maintenance, such as 10,000-mile inspections, brake work on light vehicles, and tune-ups are performed, but not major vehicle overhauls. About seven vehicle brake inspections and three brake replacements (front and back) are performed each month. The two mechanics employed at this garage are assigned to the second shift.

The building is 182 feet long, 123 feet wide, and 15 feet high (Figure 4-6). A single hydraulic lift is employed to raise light duty vehicles to the desired height for brake inspection and replacement.

Ventilation is provided by a 3,800 cfm exhaust fan on the washroom wall and another 5,000 cfm wall fan at the rear of the garage. This provides about two air changes per hour. There is no provision for make-up air except for infiltration through doors and windows. This may result in negative pressure in the building, especially when the doors are closed in cold weather. The garage is steam heated and is not air-conditioned. A carbon monoxide monitoring system is set to operate an auxiliary ventilation fan if the carbon monoxide level reaches 35 to 39 ppm.

* Nilfisk Vacuum Cleaner Model GS-81, Nilfisk of America, Malvern, PA.

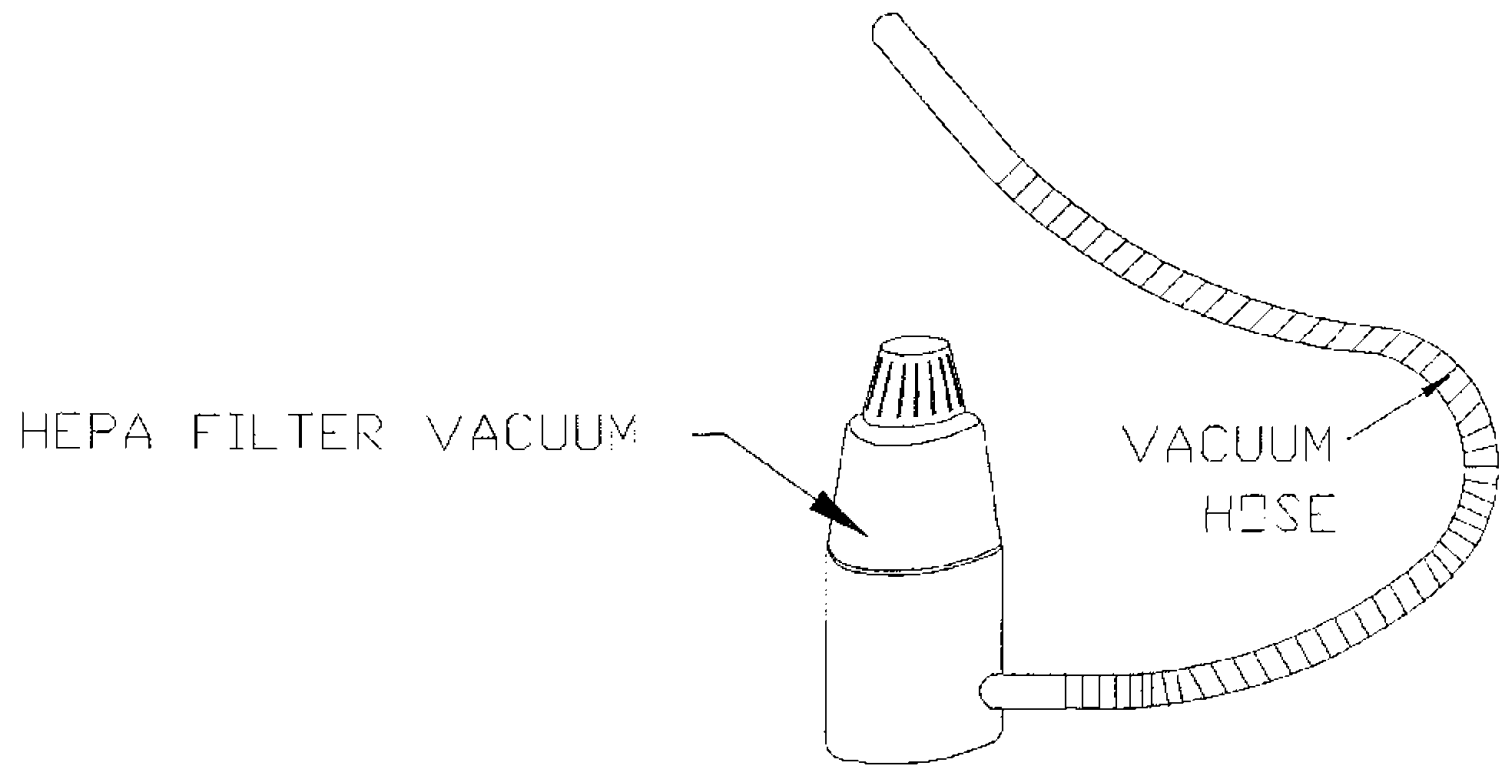
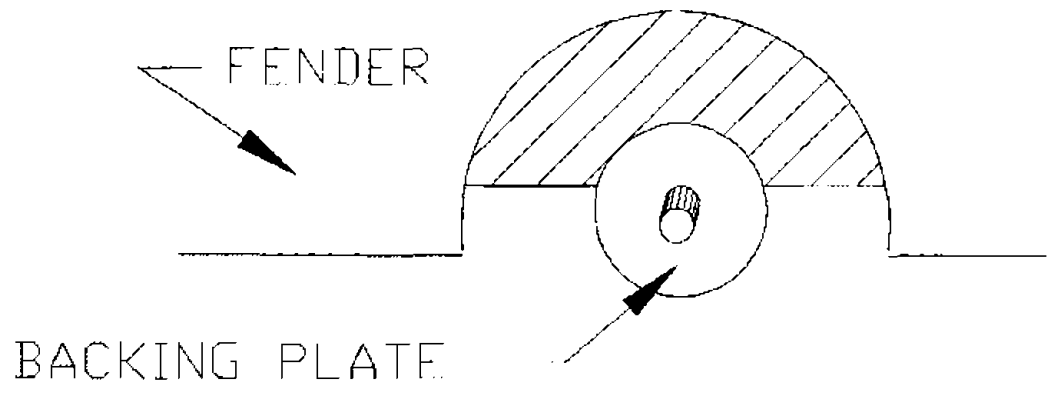

Figure 4-5. Vacuum with HEPA filter.

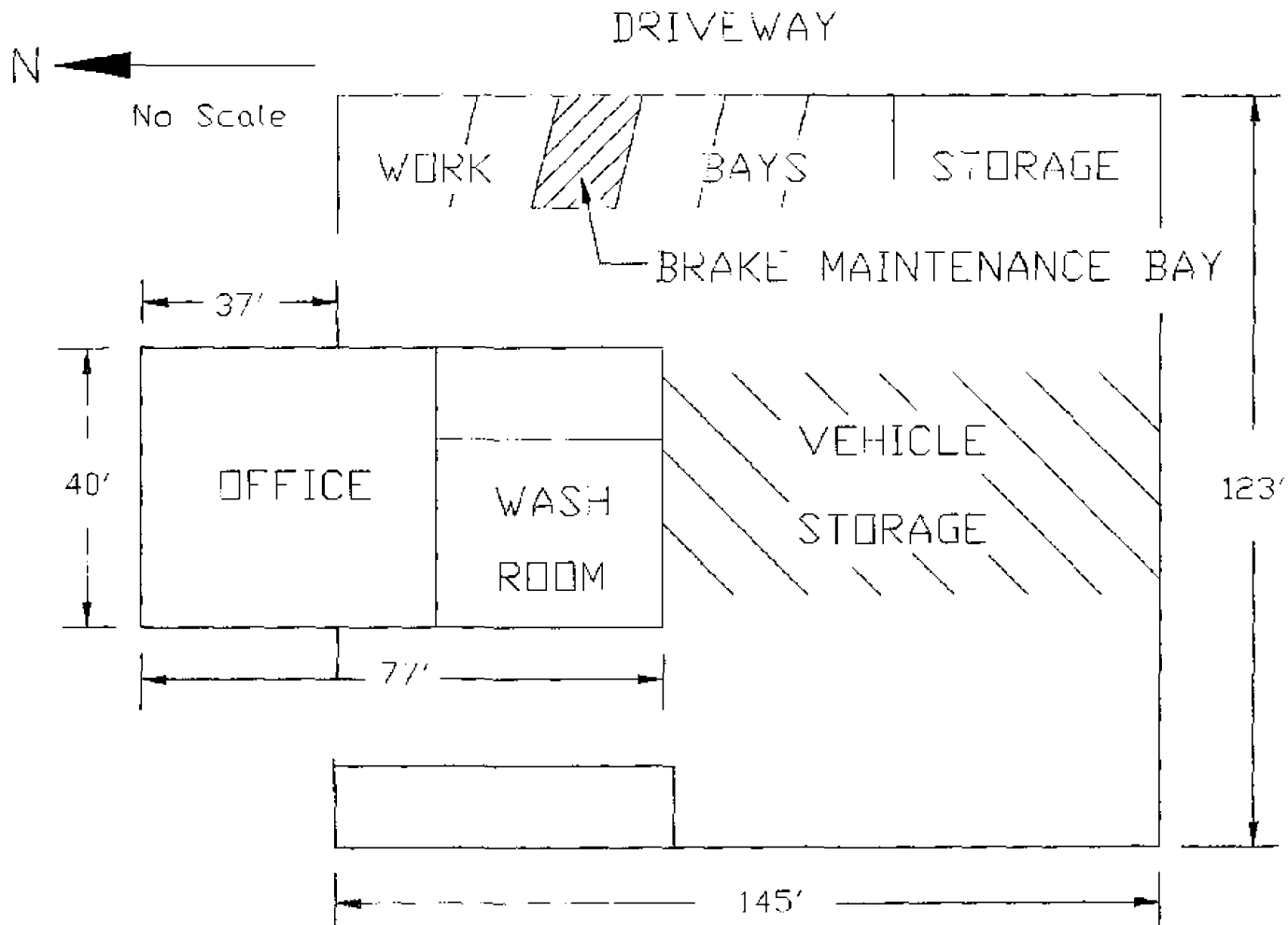

Figure 4-6. Layout of garage with vacuum.

During the November 24 and December 9, 1986, surveys, the main doors of the garage were generally open, which provided some air circulation within the garage. However, during the surveys conducted on December 11 and 16, 1986, and January 12 and February 5, 1987, the doors were closed except for vehicle entry and exit.

Brake servicing using the vacuum only control was evaluated on seven vehicles -- two automobiles and five utility vans -- all with rear drum brakes. The model years ranged from 1977 to 1982 and the mileage ranged from 52,000 to 92,000 miles.

4.4. WET BRUSH/RECYCLE*

4.4.1. Control Description

Asbestos exposure is controlled by a brake washer assembly (Figure 4-7). An aqueous solution containing an organic solvent is pumped through a nylon filter, directed through a flexible tube and out between the bristles of a brush. It provides for a gentle flooding of the brake assembly area to wash down dust and perform the necessary cleaning. The solution captured in a catch pan is returned to and recirculated from a reservoir.

This system provides a gentle flow of solvent to wet and clean the back plate and brake components without discharging brake dust into the air. A movable workshelf/catch basin can be positioned to avoid splashes and spills. The low center of gravity of the unit resists tipping and potential spilling of the cleaning solution which may contain asbestos fibers. A removable cover for the reservoir prevents evaporation of the liquid and serves as a work tray when the cover is removed for work on large vehicles. The portable washer can be used for brake maintenance of both automobiles and trucks.

The following sequence is used for brake shoe servicing: The reservoir is filled with 1 gallon of brake cleaner concentrate and 5 gallons of water. The brush is placed in the catch basin to prevent accidental spillage and loss of solution. With the vehicle on a lift, the lug nuts, wheel, and brake drum are removed and the washer is placed so that the catch basin is directly under the brake assembly. (If the vehicle is raised by a front-end lift or jack, the catch basin and the hinged reservoir cover can be removed, and cleaning can be performed over the expanded metal mesh shelf in the reservoir tank.) When the washer is properly positioned, the pump is started and the fluid flow is controlled by a valve at the hose-pump connection. The brush is used to assist in the removal of dust, asbestos fibers, oil, and grease from the brake drum and brake assembly. Small parts are cleaned and stored in the catch basin or on the screen in the main tank. After cleaning, the brake is inspected and then either reinstalled or repaired.

* Kleer-Flo Model LW-22 Rollabout®, Kleer-Flo Company, Eden Prairie, MN.

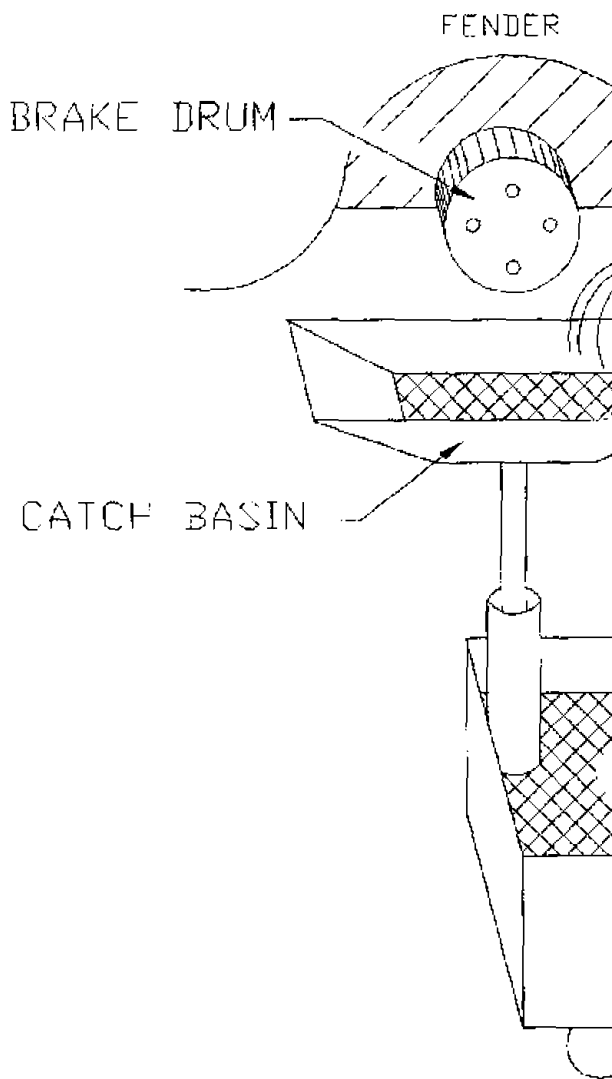
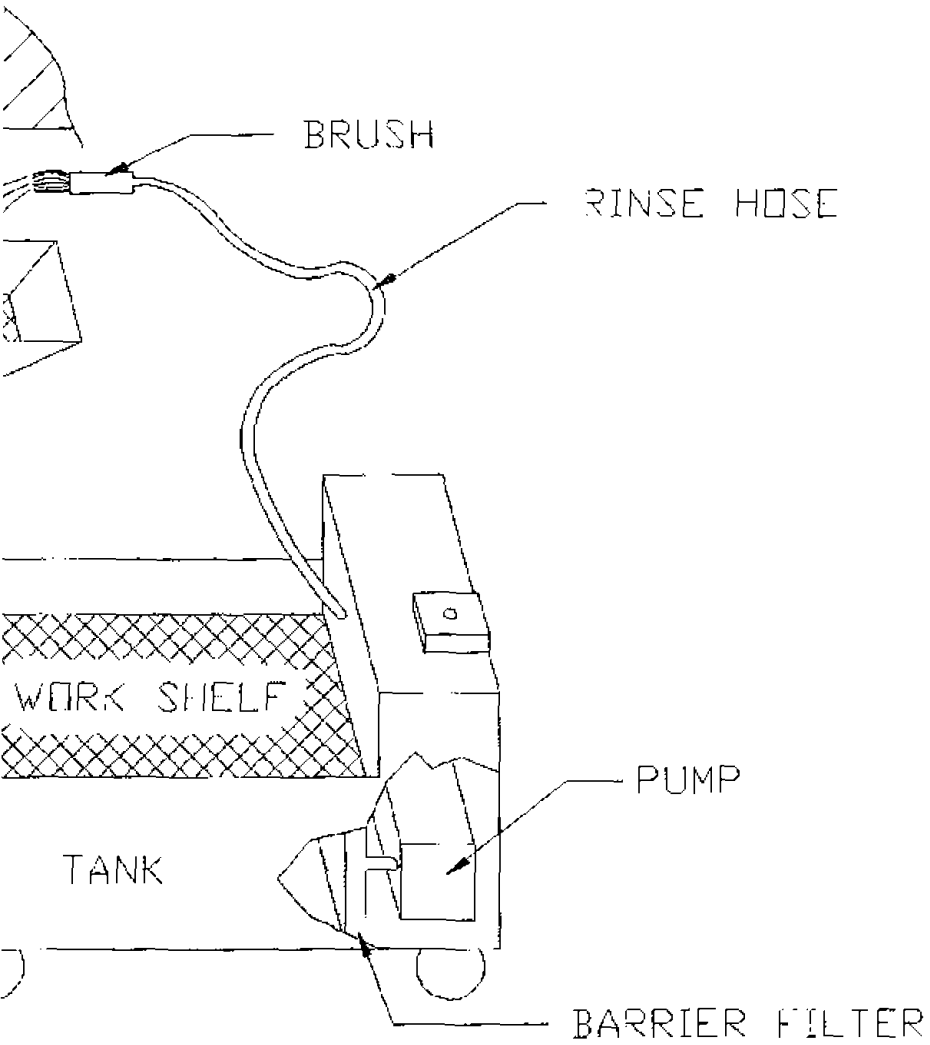

Figure 4-7.



Wet brush/recycle system.

One gallon of Greasoff® No. 19 mixed with 5 gallons of water is used to clean 40 to 50 wheels before it is disposed of in accordance with local, state, and federal requirements. The barrier filter should be washed at that time.

At this facility, the unit was somewhat awkward to shift from wheel to wheel because it had to be moved over electrical cords or air lines on the floor. However, the workers were confident that the unit did reduce their exposure to asbestos in the brake dust, that it allowed the brake components to be cleaned well, and that it was easy to use.

4.4.2. Facility Description

This control method was evaluated at a postal maintenance garage which services 575 vehicles. The 202-foot-long garage building (Figure 4-8) was opened in 1979-80. It includes a 64 by 111-foot working area with a 20-foot ceiling. There are 14 bays, 12 are equipped with hydraulic lifts. The garage staff consists of ten mechanics, four garagemen, one body man, and two supervisors. Each vehicle is completely inspected twice a year; approximately 25 brake jobs are performed each month.

Ventilation of the garage is minimal. Under-floor hose and pipe systems to remove auto exhaust fumes are used only when a vehicle engine is operating. Several roof-mounted fans on each side of the garage are operated in the summer to remove hot air from under the roof area. In the cooler months, these fans are not used and the inlet dampers are closed. There is no provision for fresh, heated air. During mild weather ventilation is provided by the open bay doors. The building is heated to about 60 to 65° F at the working level during cold weather. During most of the survey, one or more doors were open.

The evaluation of brake maintenance using the wet brush/recycle method was performed on 10 Jeep vehicles manufactured in 1973 through 1986. All four wheels are equipped with drum brakes; drum sizes ranged from 9 to 11 inches.

4.5. AEROSOL SPRAY*

4.5.1. Control Description

This control method consists of a solvent (methyl chloroform) spray to control potential asbestos exposures during brake maintenance on all types of vehicles. Typically, the operator dispenses the solvent from a refillable, hand-held sprayer (Figure 4-9). The sprayer is filled with approximately 1 quart of solvent; the solvent is transferred to the sprayer from a 55-gallon drum using a drum-mounted pump. Shop air at approximately 200 psig is used to pressurize the sprayer.

In the brake cleaning procedure, the hubcap, wheel, and drum are removed. A catch pan is placed under the brake assembly and the exposed surfaces are

* Balkamp 770-551 Model A Sprayer, Balkamp Central Div., Indianapolis, IN.

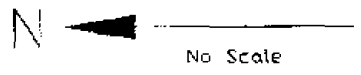

MAINTENANCE GARAGE (202' x 64')

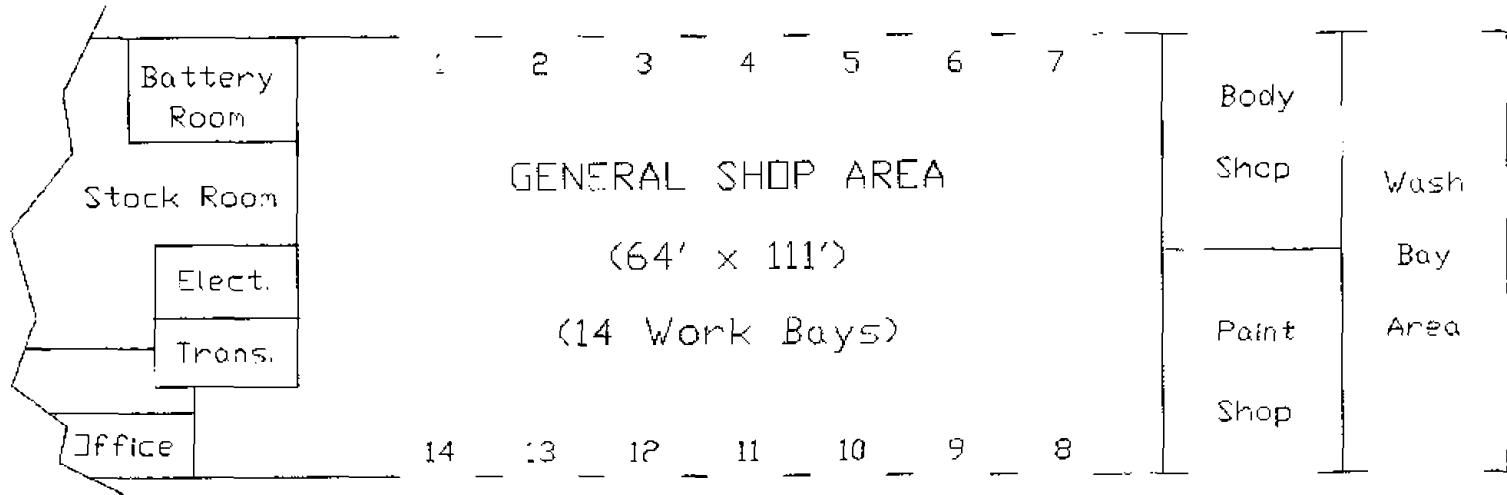

Figure 4-8. Layout of garage with wet brush/recycle.

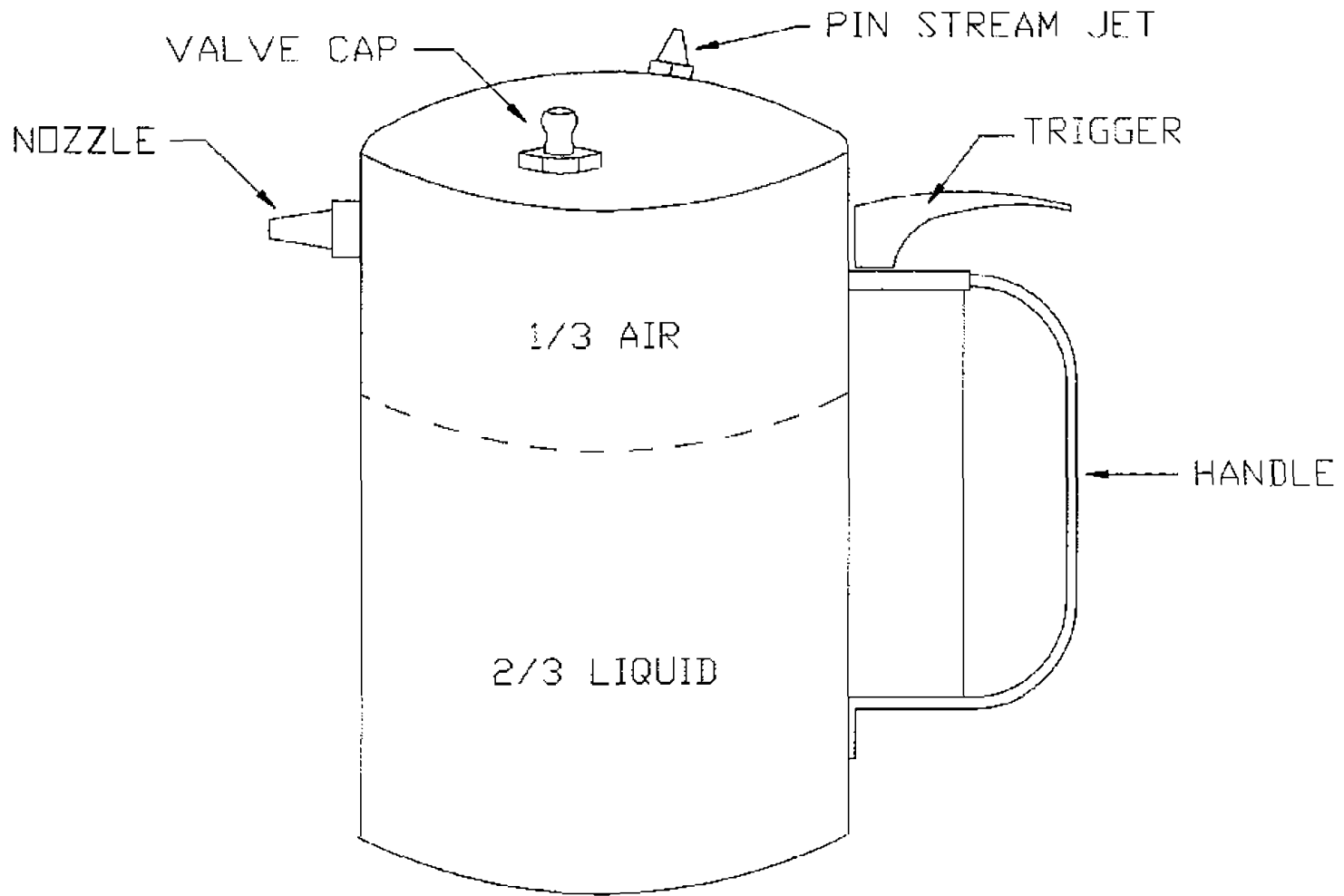

Figure 4-9. Aerosol sprayer.

thoroughly wetted. The sprayer is held about 18 inches from the brake drum and the other components so that brake dust is not blown off to become airborne before it is wetted. Washing is then performed by moving the sprayer to about 12 inches from the parts. The contaminated solvent is collected in the catch pan. It is not recycled, but is emptied into a waste drum to be disposed of as toxic waste. Some mechanics wipe the parts and drum with dry rags. After cleaning, the brake is inspected and then either reinstalled or repaired.

Occasionally, the solvent is applied directly to the brake drum and brake components with a parts brush (manual wet brush method) to remove the brake residue. The catch pan, containing about 2 inches of solvent, is placed on the floor near the vehicle. The brake drum is removed, placed in the catch pan, cleaned with a solvent laden brush, and then wiped with a dry rag. The pan is then placed under the wheel to catch the excess, contaminated solvent as the other brake system components are also cleaned with the brush. The clean components are wiped with a dry rag and the contaminated solvent is emptied into a waste drum and disposed of as toxic waste.

The unit is small, lightweight, and appears easy to use. It seems to do a good job in cleaning the brake components and has very little contaminated solution to dispose of. One disadvantage occurs when it is first activated to clean a wheel. If the nozzle is too close to the brake surfaces, within about 12 inches, pressure from the nozzle causes brake dust to become airborne.

4.5.2. Facility Description

This private utility has 10 garages to service about 1,400 vehicles. The buildings range in size from a single-bay workstation to a 14-bay garage. Maintenance is performed on cars, pickup trucks, vans, specialty vehicles slightly larger than a pickup truck, medium size trucks, and large specialized line trucks. The annual maintenance of these vehicles includes brake inspection. Each month, all the wheels on approximately 30 to 35 vehicles are pulled for brake inspection and 65 to 70 percent of these undergo brake replacement or repair. A total of 89 mechanics at these 10 installations perform brake maintenance.

In our study, brake service was evaluated at four of these garages.

The first, located in a congested industrial area, is part of a larger building. Maintenance is performed on 250 vehicles assigned to this location by 10 mechanics in a 13,000-square-foot area containing 10 work bays. Outside air is drawn in through gas-fired heaters; building air is exhausted by window-mounted fans. Because of the mild weather, doors were open and the fans were not in use during the study.

The second garage is located beneath a high-rise office building in the downtown area. Maintenance services are performed on 225 vehicles, mainly automobiles, by 5 mechanics in a 1,500 square-foot area containing 3 work bays. Fresh air, entering through a wall duct, exhausts naturally into an alley next to the garage.

The third garage, located in a rural area, is a 3,300 square-foot structure. Although not in use at the time of the study, two roof-mounted exhaust fans are present. Maintenance is performed on 115 vehicles by 7 mechanics in 4 work bays.

The fourth garage is part of a large 45,400 square-foot multipurpose facility located in a congested industrial area. Maintenance is performed on 150 vehicles by 8 mechanics in a 5,500 square-foot area containing 3 work bays. The two wall-mounted exhaust fans were not operated during the study; however, open doors leading to the rest of the building provided ventilation.

The study of the aerosol spray method was performed during brake servicing to six vehicles at these four garages; in one case the mechanic serviced two vehicles. Only five sets of samples were obtained for this method. One large truck with rear wheels and 16.5-inch drums was studied in addition to five automobiles with smaller drums.

4.6. Rudimentary Controls and No Controls

Airborne asbestos concentrations were measured during brake servicing of the rear brakes on a full-size van by a "do-it-yourself" mechanic. A spray can solvent was used to wet the brake drum surfaces and dissolve accumulated grease and dirt, and a garden hose to flush the surfaces with water. The work was performed in a driveway, out-of-doors.

Asbestos concentrations were also measured during servicing of the rear brakes on a utility vehicle. No dust controls were used; the brake drums were banged on the floor to remove the dust. The cleaning of the brake drum was of very short duration and the brake assembly was not cleaned. The work was performed in a small service station garage and the doors were open during the sampling period.

5. RESULTS

5.1. ASBESTOS CONCENTRATIONS AS DETERMINED BY PCM

The average and range of personal sample concentrations for airborne asbestos fibers determined by PCM are presented in Table 5-1 for the five different control methods used during brake service. These results include exposures encountered while workers serviced brakes of small and medium size vehicles and two large vehicles. Area samples (PCM) collected near the fender and over the axle of all vehicles were less than 0.002 f/cc (see Table 5-2).

Of 83 personal samples collected on brake mechanics in the present study, the highest concentration determined by PCM was 0.016 f/cc. This is about four times the LOD for the personal samples (0.004 f/cc). Personal sample concentrations represent only those exposures which occurred while servicing brakes (usually 2 to 3 hours per shift), and not the time-weighted average exposure for the entire work shift. Usually only one brake repair was performed per day, thus the time-weighted average exposure of the mechanic would be lower. Arithmetic mean fiber concentrations while using either of the vacuum enclosures or the wet brush/recycle with recirculating solution were ≤ 0.004 f/cc. Exposures while using the vacuum only and the aerosol spray methods were ≤ 0.016 f/cc.

For vacuum enclosure A, all 18 personal sample concentrations, as determined by PCM, were less than the LOD. Figure 5-1 shows the percentage of personal samples that were below the LOD of 0.004 f/cc for each of the five control methods. For vacuum enclosure B, 21 of 22 personal sample concentrations were below the LOD.

The exposure for a "do-it-yourself" mechanic using a spray can solvent and garden hose during a brake replacement averaged 0.007 f/cc using Method 7400 "A" rules (Table 5-1). A brake service operation was sampled in which no dust controls were used and the brake drums were banged on the floor to remove dust; fiber concentrations (PCM) for both personal samples were below the LOD of 0.008 f/cc (Method 7400 "A" rules).

The OSHA permissible exposure limit (PEL) of 0.2 f/cc (OSHA action level 0.1 f/cc)⁽³⁰⁾ (8-hour, time-weighted average) and the NIOSH recommended exposure limit (REL) of 0.1 f/cc⁽²⁸⁾ are based on the PCM analysis of asbestos using "A" counting rules (3:1 aspect ratio). "B" counting rules (5:1 aspect ratio) were used in this study, except where noted, and the results cannot be directly compared to the OSHA PEL or NIOSH REL. However, TEM analysis of the filter air samples showed that 82 to 95 percent of all fibers counted using a 3:1 aspect ratio would also have been counted if a 5:1 aspect ratio was used. This

Table 5-1

Personal Sample Fiber Concentrations by Control Method (PCM)

Control Method	Number of Samples	Arithmetic Mean (f/cc)	Range (f/cc)
Vacuum enclosure A	18	<0.004	<0.004
Vacuum enclosure B	22	<0.004	<0.004 - 0.006
Vacuum only	13	0.007	<0.004 - 0.016
Wet brush/recycle	20	<0.004	<0.004 - 0.006
Aerosol spray	8	0.007	<0.003 - 0.016
Uncontrolled	2	<0.008	<0.008
Water hose and solvent	2	0.007	<0.006 - 0.008

35

Table 5-2

Source Sample Fiber Concentrations (PCM)

Control Method	Fender			Axle		
	Number of Samples	Arithmetic Mean (f/cc)	Range (f/cc)	Number of Samples	Arithmetic Mean (f/cc)	Range (f/cc)
Vacuum enclosure A	9	<0.002	<0.002	9	0.001	<0.002
Vacuum enclosure B	7	<0.002	<0.002	8	<0.002	<0.002
Vacuum only	5	<0.002	0.002	5	<0.002	<0.002
Wet brush/recycle	10	<0.002	<0.002	10	<0.002	<0.002
Aerosol spray	3	<0.002	<0.002	3	<0.001	<0.001

PERSONAL SAMPLES (FIBERS/CC)

PERCENT OF SAMPLES

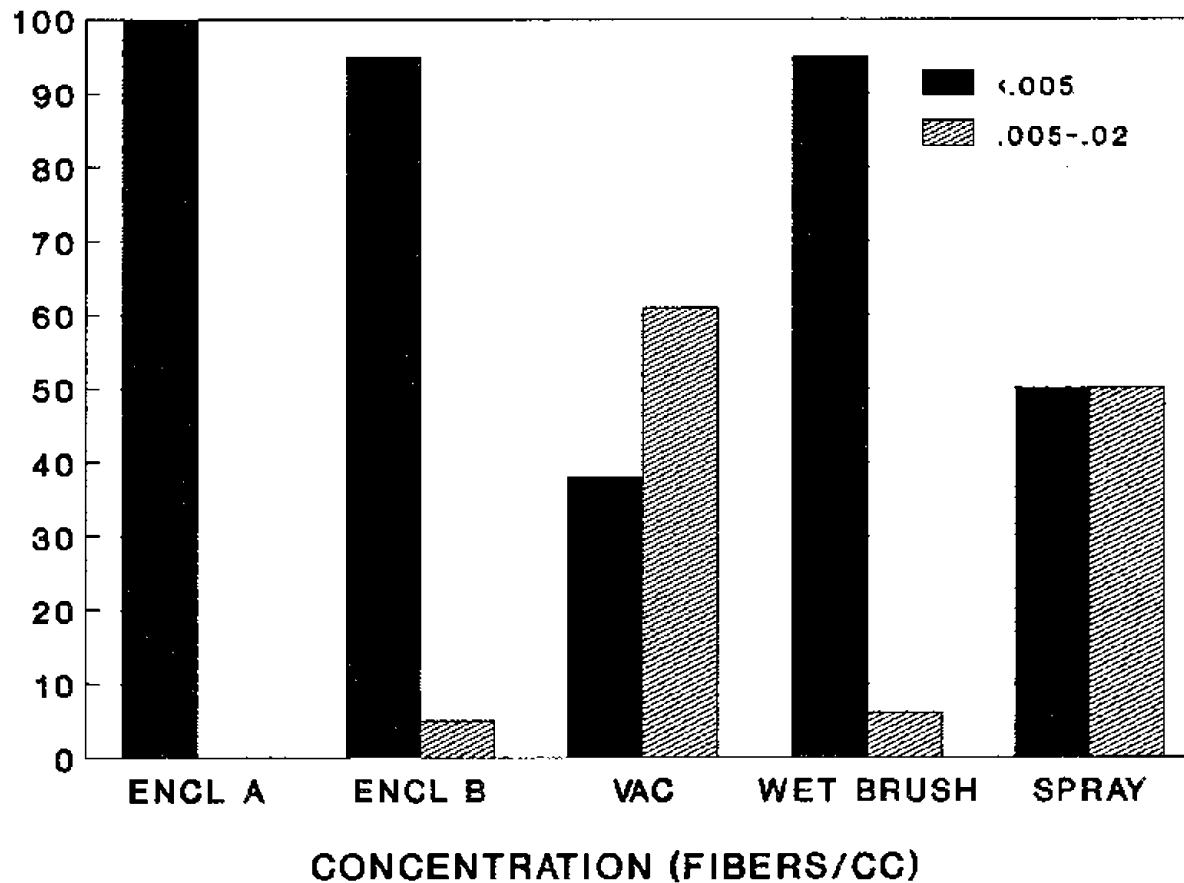

OSHA STD. 0.2 F/CC

Figure 5-1. PCM fiber concentrations.

analysis indicates that there would be little difference in fiber concentrations using either fiber aspect ratio criteria.

Personal samples analyzed by PCM indicated that the TWA exposures of the mechanics would be all below the NIOSH REL for asbestos of 0.1 f/cc and the OSHA PEL of 0.2 f/cc, even if they performed brake servicing for the entire work shift. In most cases, the mechanics performed only one or two brake jobs per day so that their TWA exposure would generally be less than the levels shown in Table 5-1.

5.2. ASBESTOS CONCENTRATIONS AS DETERMINED BY TEM

TEM results are not directly comparable to the PCM data because: (1) TEM counts include all fibers, regardless of length; whereas PCM includes only fibers greater than 5 μm in length; (2) TEM counts include fibers too thin to be seen using PCM; and (3) TEM data include only fibers identified as asbestos; whereas PCM data include any fiber type. The TEM analyses showed that only 8 of 57 personal samples contained asbestos fibers 5 μm or longer.

5.2.1. Personal Sampling Results

Asbestos concentrations obtained in the breathing zone of the mechanics and analyzed using TEM are summarized in Table 5-3 for each of the 5 control methods evaluated. (These results exclude exposures encountered while workers serviced brakes to the two large vehicles.) All fibers identified as chrysotile or amphibole asbestos with an aspect ratio of 3:1 or greater were counted (fibers $\geq 0.2 \mu\text{m}$ in length). Amphibole asbestos was found on only 7 of 219 filter air samples analyzed (one or two amphibole fibers per filter).

Arithmetic mean asbestos exposures ranged from less than 0.013 f/cc while using the wet brush/recycle with recirculating solution to 0.052 f/cc for the aerosol spray method. Personal sample concentrations were found to be at the low end of this range for vacuum enclosure A and the vacuum only system; and at the high end for the vacuum enclosure B. The arithmetic mean exposures for the aerosol spray and enclosure B were significantly higher than that for the wet brush recycle ($p < 0.05$). The arithmetic mean exposures for the vacuum enclosure A and for the vacuum only system were not significantly different than that for the other three methods. Geometric mean asbestos exposures ranged from less than 0.013 to 0.045 f/cc for the five control methods evaluated. The geometric mean exposures for the mechanics using the spray can and garden hose and using no control were 0.039 and 0.048 f/cc, respectively. The arithmetic and geometric mean exposures are illustrated in Figure 5-2.

5.2.2. Source Sampling Results

Asbestos concentrations near the vehicle fender and axle (excluding the two large trucks) are presented in Table 5-4. Arithmetic mean asbestos concentrations near the fender ranged from 0.006 f/cc to 0.115 f/cc; arithmetic

Table 5-3

Personal Sample Asbestos Concentrations by Control Method (TEM)

Control Method	Number of Samples	Arithmetic Mean (f/cc)	Standard Deviation	Range* (f/cc)	Geometric Mean (f/cc)
Vacuum enclosure A	16	0.021	0.015	0.010 - 0.065	0.017
Vacuum enclosure B	12	0.044	0.042	<0.013 - 0.139	0.028
Vacuum only	13	0.022	0.012	<0.011 - 0.045	0.019
Wet brush/recycle	10	<0.013	0.0002	<0.013 - <0.014	<0.013
Aerosol spray	6	0.052	0.023	0.013 - 0.079	0.045
Uncontrolled	2	0.061	0.037	0.024 - 0.097	0.048
Water hose and solvent	2	0.039	0.001	0.039	0.039

Note: Limits of detection vary with the sample volume

38

Table 5-4

Source Sample Asbestos Concentrations (TEM)

Control Method	Fender				Axle			
	No. of Samples	Arith. Mean	Geom. Mean	Range (f/cc)	No. of Samples	Arith. Mean	Geom. Mean	Range (f/cc)
Vacuum enclosure A	8	0.010	0.007	<0.004 - 0.031	8	0.009	0.006	<0.003 - 0.028
Vacuum enclosure B	11	0.024	0.015	<0.005 - 0.092	11	0.027	0.012	<0.004 - 0.164
Vacuum only	5	0.008	-	<0.004 - 0.015	5	0.008	-	<0.004 - 0.020
Wet brush/recycle	10	0.010	-	<0.004 - 0.040	10	<0.006	-	<0.004 - 0.016
Aerosol spray*	2	0.115	-	0.063 - 0.166	2	0.023	-	0.022 - 0.023
Water hose/solvent	1	0.006	-	-	1	0.017	-	-
Uncontrolled	1	0.036	-	-	1	<0.006	-	-

* Three brake jobs evaluated.

ASBESTOS CONCENTRATION (FIBERS/CC)

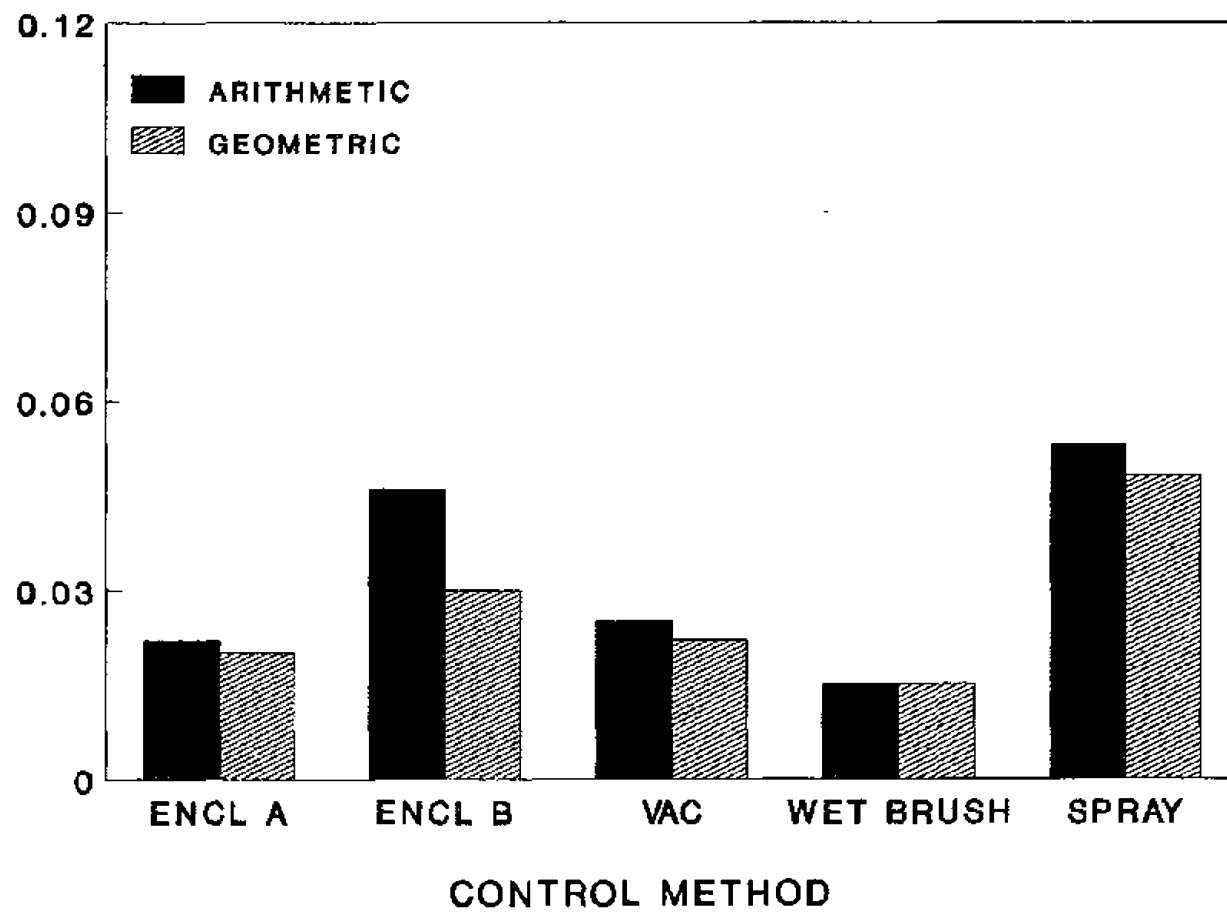

Figure 5-2. Arithmetic vs geometric mean asbestos exposure (TEM).

mean asbestos concentrations near the axle ranged from less than 0.006 f/cc to 0.027 f/cc. The aerosol spray method resulted in the highest average fender concentration (0.115 f/cc). This is about 5 times the average fender concentration for vacuum enclosure B and an order of magnitude higher than that for the other three control methods.

The use of vacuum enclosure B resulted in the highest average axle concentration. Dust was observed to escape from the seal of this enclosure during brake cleaning with compressed air. One axle sample was six times the highest axle concentration of any of the other controls.

5.2.3. Background Sampling Results

Indoor ambient, arithmetic mean asbestos concentrations as determined by TEM (Table 5-5) are compared to arithmetic mean asbestos exposures in Figure 5-3 for the five control methods evaluated. Arithmetic mean asbestos concentrations inside the garages were 0.006 f/cc or less. These data indicate that nearly all the asbestos exposure for the mechanics was due to job tasks and not indoor background asbestos concentrations.

5.2.4. Outdoor Ambient Sampling Results

Outdoor ambient, arithmetic mean concentrations were 0.006 f/cc or less (Table 5-5). Of 32 ambient samples analyzed by TEM, 24 were less than the LOD of about 0.005 f/cc.

5.2.5. Bulk and Settled Dust Samples

A bulk sample of brake dust was collected from each vehicle serviced to determine if the friction materials contained asbestos. Each brake dust sample consisted of a few grams of dust from each of the vehicle's rear drums (and the front drums of jeeps) combined into a single sample vial; 43 bulk brake dust samples were collected. Bulk samples were analyzed for asbestos by TEM. Generally, less than 1 percent of the particles present in the bulk brake dust samples was asbestos; although several samples contained as much as 1 percent asbestos. These results are summarized in Table 5-6.

Settled dust from one or more sites within each facility were similarly collected and combined into a single bulk sample. The settled dust samples were collected to indicate the potential for building contamination.

Most of the fibers present in both the brake and settled dust samples were chrysotile asbestos. Fewer than one in a thousand asbestos fibers in the bulk brake dust samples were amphibole asbestos. Two of seven settled dust samples contained amphibole asbestos; one settled dust sample contained 20 percent (of total fibers) amphibole asbestos, possibly from the insulation used on the hot water pipes in the garage. Other fibers in both the brake dust and settled dust samples were determined to be nonasbestos. (37)

Table 5-5

Asbestos Ambient Concentrations as Determined by TEM

Facility	Indoor Ambient			Outdoor Ambient		
	No. of Samples	Arithmetic Mean (f/cc)	Range (f/cc)	No. of Samples	Arithmetic Mean (f/cc)	Range (f/cc)
Vacuum enclosure A	11	0.004	<0.002 - 0.012	10	0.005	<0.003 - 0.016
Vacuum enclosure B	5	0.002	<0.002 - 0.003	4	0.006	<0.004 - 0.008
Vacuum only	7	0.006	<0.004 - 0.012	7	<0.004	<0.003 - <0.005
Wet brush/recycle	8	0.003	<0.002 - 0.006	4	0.003	<0.003 - 0.003
Aerosol spray	7	0.003	<0.002 - <0.010	7	<0.006	<0.004 - 0.012

ASBESTOS (FIBERS/CC)

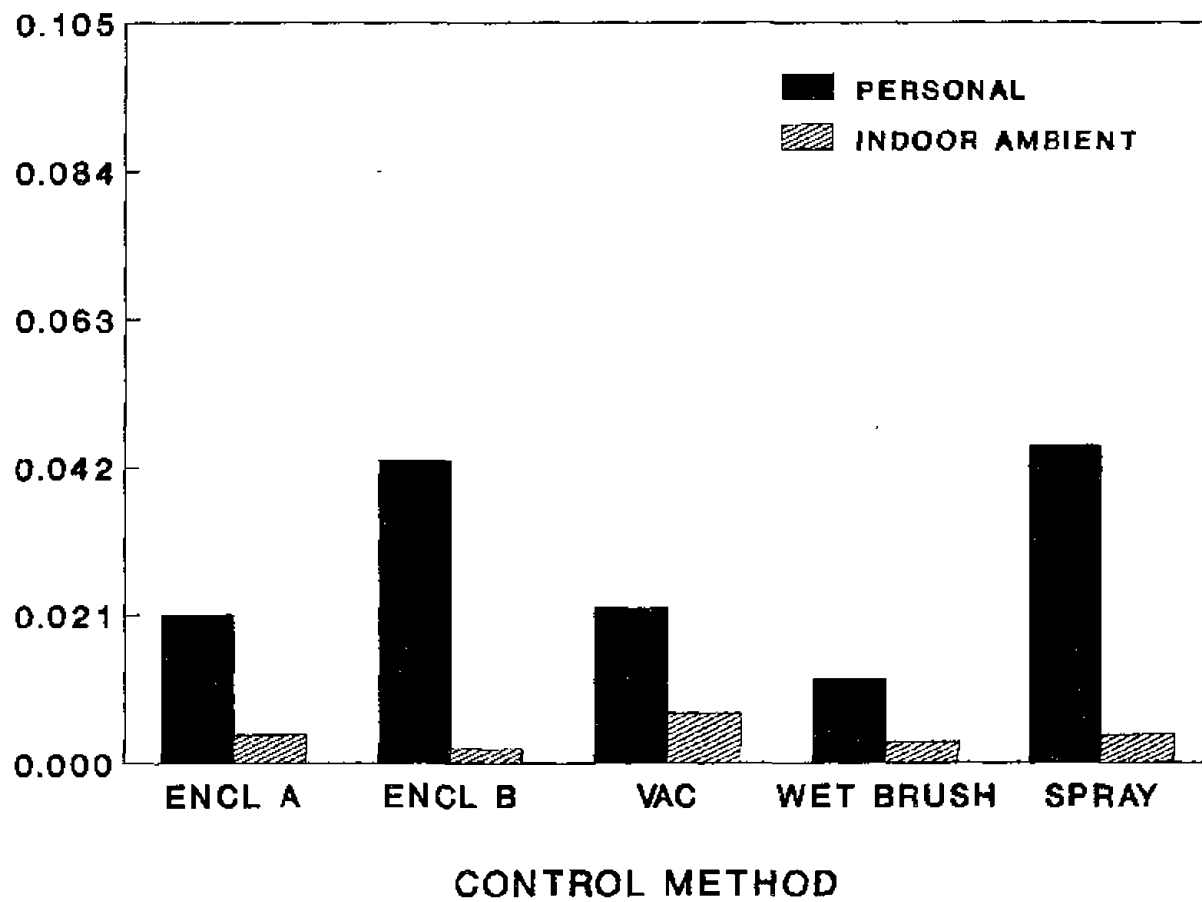

Figure 5-3. Personal vs background asbestos levels (TEM).

Table 5-6

TEM Analysis of Bulk Brake and Settled Dust Samples

Control	Sample type	Number of samples	Percent asbestos in total dust	Percent asbestos of total fibers	Percent of fibers* >5 μm in length
Vacuum enclosure A	brake dust	9	<1	54 - 100	1 - 17
	settled dust	1	NA	85	5
Vacuum enclosure B	brake dust	11	<0.1 - 1	0 - 100	0 - 6
	settled dust	1	<1	60	0
Vacuum only	brake dust	6	<0.1 - 1	24 - 100	0 - 9
	settled dust	1	<0.1	68	0
Wet brush/recycle	brake dust	9	<1	83 - 100	0 - 3
	settled dust	1	NA	99	7
Aerosol spray	brake dust	6	<1	74 - 100	1 - 16
	settled dust	3	<1	56 - 84	0 - 7
No control	brake dust	1	<0.1	99	0
Water hose and solvent	brake dust	1	NA	84	0

* includes fiber bundles

NA: not available

While the percentage of fibers longer than 5 μm for most vehicles was less than about 3 percent, the brake dust from a few vehicles contained a substantially greater percentages of fibers longer than 5 μm . No obvious trends were observed (e.g., vehicle size) which could account for the presence of these long fibers. TEM analysis of the bulk brake dust samples showed that the aspect ratio of 90 to 97 percent of fibers was greater than or equal to 5:1 for each of the five major controls evaluated.

5.2.6. Field Blanks

One or two field blanks were prepared for each vehicle evaluated and submitted for PCM and TEM analysis. Fifty-one blanks were analyzed by PCM and 34 blanks by TEM; these results are summarized in the Appendix. Analysis by PCM showed that all blanks were below detectable limits, and that 3 of the 34 blank samples analyzed by TEM contained a single asbestos fiber. Because of the very low asbestos fiber counts on the blanks, no blank correction was made to the TEM sample results.

5.3. LARGE VEHICLES

Two vehicles with rear wheel brake drums 16 to 17 inches in diameter were evaluated in this study. A salt truck was sampled while using vacuum enclosure A and a boom truck was sampled using the aerosol spray method. As shown in Table 5-7, fiber concentrations determined by PCM for both large vehicles were below 0.004 f/cc LOD; however, asbestos exposures determined by TEM analysis were 0.15 f/cc for the salt truck and 0.88 f/cc for the boom truck. These results are based on two simultaneous personal samples taken during brake service to the rear wheels of the respective vehicles. In Figure 5-4, the results for these two vehicles are compared to the maximum asbestos concentrations (TEM) measured during brake service to vehicles with 8- to 12-inch drum sizes using the same controls.

5.4. REAL-TIME SAMPLING RESULTS

Real-time data were obtained during most of the brake maintenance jobs evaluated and collected on 26 operators performing brake maintenance jobs to 36 vehicles. The data collection took place during actual brake maintenance operations and lasted approximately an hour. The HAM was located next to the personal filter sampler in the breathing zone of the brake mechanic.

The general brake maintenance procedure as monitored using the real-time instrumentation was:

1. The vehicle was driven into the work area and raised off the floor from a few inches to 4 feet.
2. The lug bolts and wheel were removed. On some vehicles, the brake drum was attached to the wheel, so it was also removed at this time.

Table 5-7

Asbestos and Fiber Concentrations During Servicing of Large Drum Brakes

Control	Vehicle	Drum Size (in)	TEM			PCM
			Personal ^a (f/cc)	Fender ^b (f/cc)	Axle ^b (f/cc)	Personal ^a (f/cc)
Vacuum enclosure A	Salt truck	17	0.15	0.16	0.33	<0.004
Aerosol spray	Boom Truck	16.5	0.88	0.11	0.02	<0.003

^a Two samples

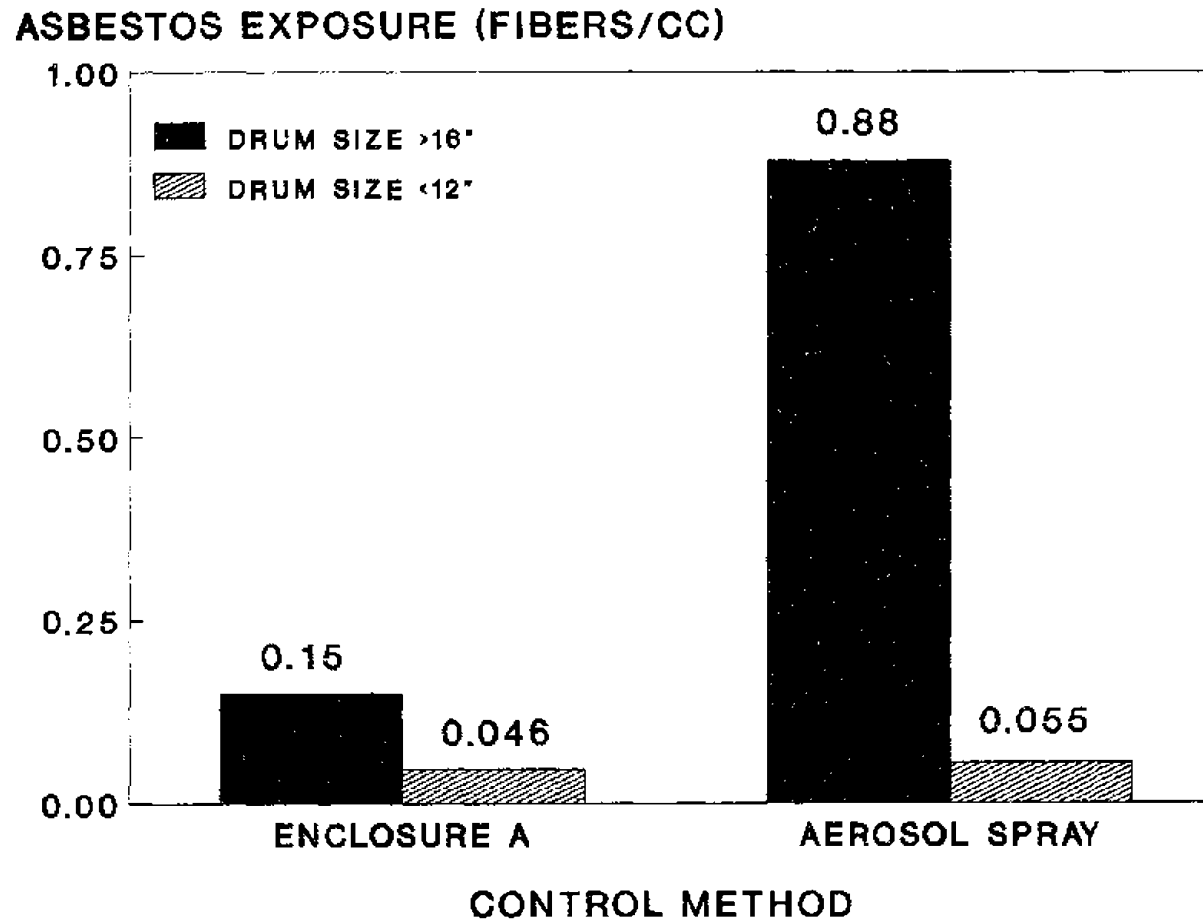

ANALYSIS BY TEM

Figure 5-4. Asbestos exposures: Large trucks vs smaller vehicles.

3. The brake drum was removed.
4. The brake dust from the brake drum and backing plate were removed using the dust control being evaluated. For the wet wash control methods, cleaning was started before the drum was removed. For vacuum enclosure A, the drum was removed while it was inside the enclosure and then cleaned.
5. The brake components were inspected. If brakes needed replacement, the brake components were removed. Some control methods (vacuum, wet wash/recycle, and wet spray) were used during removal for additional brake dust control and cleaning purposes.
6. The new brake shoes and components were installed.
7. The brake drum was reinstalled.
8. The wheel was remounted and the lug bolts tightened.
9. The vehicle was test driven and the brakes were adjusted if needed.

From 600 to 1,900 readings were taken during each of 26 brake jobs for which real-time data was collected. The average relative dust concentration and the standard deviation for each phase of the brake maintenance job were determined. Table 5-8 shows the average relative dust levels (reported as the aerosol monitor response in millivolts) during the various brake maintenance phases for each control method. The average relative dust concentrations between the various phases were used to identify the principal sources of dust exposure during brake maintenance.

Table 5-8

Average Relative Respirable Dust Levels
(aerosol monitor response in millivolts)

	Vacuum Encl. A	Vacuum Encl. B	Vacuum Only	Wet Brush Recycle	Aerosol Spray
<u>Brake Maintenance Phase</u>					
No Activity (Background)	0.007	0.009	0.005	0.008	0.008
Remove Wheel	0.008	0.030	0.022	0.046	0.011
Remove Drum	0.008	0.018	0.011	0.021	0.027
Clean	0.007	0.011	0.007	0.007	0.011
Remove Brake Parts	0.006	0.009	0.009	0.012	0.012
Install Brakes/Drum	0.012	0.012	0.008	0.006	0.012
Remount Wheel		0.021	0.017	0.021	0.017

<u>Summary</u>					
Mean	0.008	0.013	0.008	0.011	0.012
Standard Deviation	0.027	0.032	0.015	0.034	0.009
=====					
Average TEM (f/cc)*	0.036	0.036	0.025	0.008	0.052
=====					
<u>Number of</u>					
Vehicles	6	9	8	10	2
Brake Drums Removed	12	32	16	38	4
Brake Parts Removed	2	6	16	22	4

* The real-time data is in millivolts; representing the total light scattered by the brake dust. Since the composition of the dust changes with operation, there is no simple relationship between instrument reading and TEM (f/cc) sample results.

6. DISCUSSION

6.1. CONTROL PERFORMANCE

All the control techniques studied prevented exposures in excess of the OSHA PEL or NIOSH REL as determined using the PCM analytical method.

6.1.1. Comparison to Historical Data

Roberts et. al.⁽³⁾ reported time-weighted average (TWA) exposures of about 0.2 f/cc and peak exposures of about 15 f/cc while using dry brushing, wet brushing, or compressed air during brake repair. Analyses were performed using NIOSH Method P&CAM 239 (PCM). They reported TWA asbestos concentrations during compressed air brake cleaning ranging from 0.03 to 0.19 f/cc; concentrations during wet brush brake cleaning ranged from 0.23 to 0.28 f/cc. A reported asbestos exposure using a squirt bottle to wash the brake drums was 0.21 f/cc.

Several subsequent studies have documented asbestos exposures, as determined by PCM, during brake drum servicing to passenger cars, buses, and trucks. Cheng and O'Kelly,⁽⁴⁰⁾ in a study of motor vehicle repair facilities in Hong Kong, found average exposures of 0.13 f/cc during compressed air blowing, with a maximum of 0.28 f/cc; during dry brushing, exposures averaged less than 0.1 f/cc. These results are based on short-term samples and represented a variety of vehicle sizes.

In West Germany, Rodelsperger et. al.⁽⁴¹⁾ measured asbestos concentrations during brake repair to passenger cars and found an average exposure of 0.1 f/cc during compressed air cleaning and 0.09 f/cc for dry brushing. These results were based on personal samples collected for 30 minutes to over an hour and were analyzed by PCM.

Kauppinen and Korhonen,⁽⁴²⁾ in an evaluation of brake maintenance garages and service stations in Finland, estimated, for repair of passenger car brakes, an average TWA exposure (PCM) of 0.05 f/cc during compressed air cleaning and 0.04 f/cc for dry brushing; maximum TWA concentrations for the two cleaning methods were 0.5 and 0.1 f/cc, respectively. For brake repair of trucks and buses, average TWA exposures were about 0.2 f/cc for compressed air, brushing, and wet cloth cleaning; maximum TWA's were about 0.7 f/cc for these methods. Figure 6-1 is a comparison of the average exposure (PCM) from five historic studies during compressed air cleaning with the average exposure for each technique in our study.

In a 1979 survey,⁽⁴³⁾ the rear brakes of an automobile were cleaned using compressed air. The asbestos exposure of that worker was 0.14 f/cc as

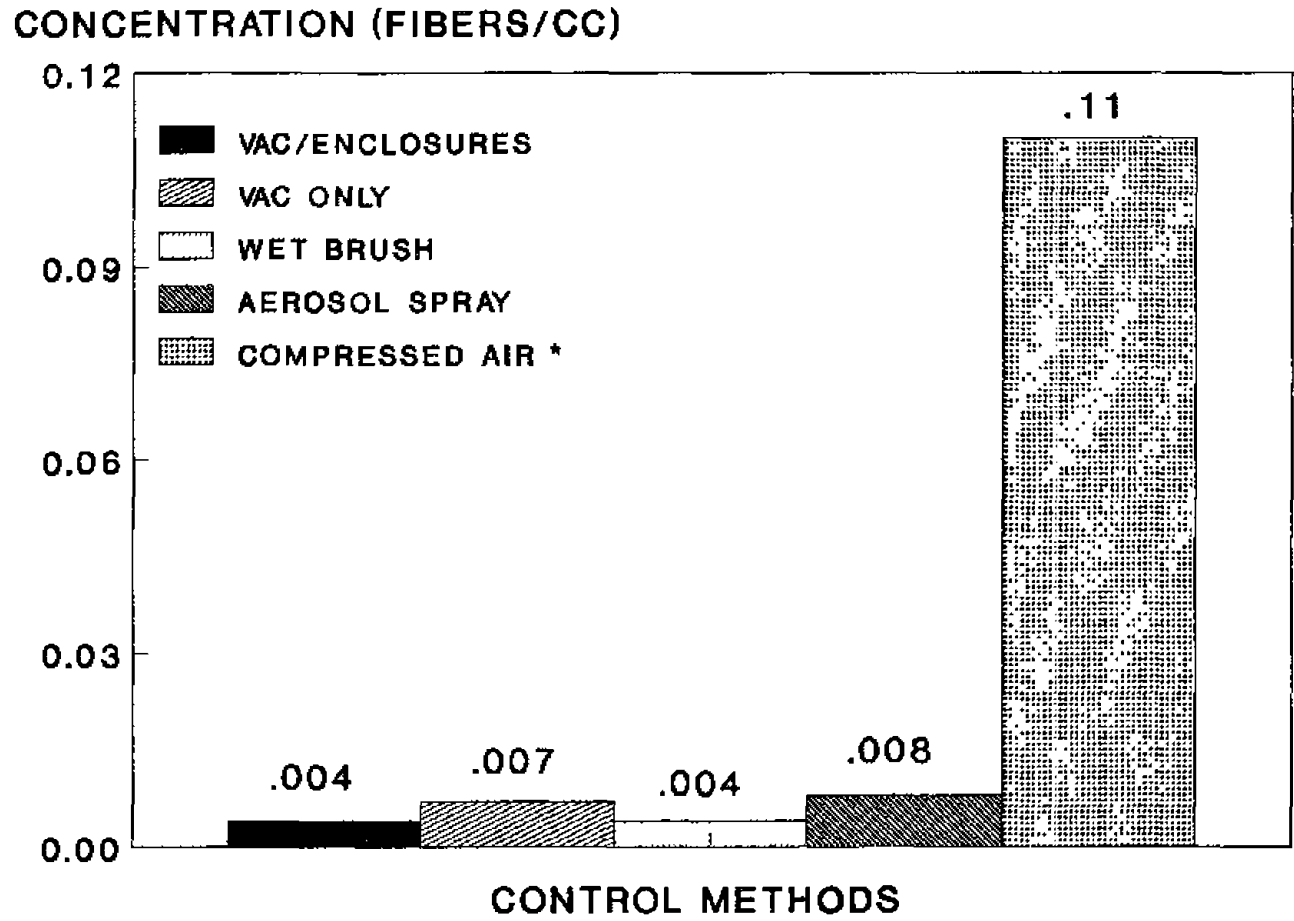

*HISTORIC DATA FROM 5 STUDIES

Figure 6-1. Fiber exposures by PCM.

determined by TEM using SAED and energy dispersive X-ray analysis and included all fibers. During this approximately 4.5-hour sample period, only the rear brakes of this vehicle were serviced. In another survey⁽⁴⁴⁾ in 1979, two personal samples were taken while a mechanic replaced the front disc and rear drum brakes of two vehicles. The sample for the first vehicle showed an asbestos concentration (TEM) of 0.20 f/cc (2-hour sample) and 0.95 f/cc (3.5-hour sample) for the second. The backing plate was cleaned with compressed air and a Stoddard solvent mixture.

A statistical comparison was made between our study results (for the servicing of vehicles such as pickup trucks, vans, automobiles, and several large trucks) and historical data (for brake servicing using compressed air, dry brushing, and squirt bottles). It showed that if variables, such as workers, vehicle types, and facilities had been controlled between our study and the historical study, then exposures in our study would be significantly lower ($p < 0.005$) for PCM exposure data.

The TEM exposure data from our study were an order of magnitude lower than those of the 1979 surveys.^(43,44) This, again, demonstrates a major difference between exposures when using the controls evaluated in our study and the methods used in the earlier studies.

6.1.2. Comparison to No Controls

No facility could be found in our study where compressed air (except within a vacuum enclosure) or dry brushing were used to clean vehicle brakes. In a study of Pennsylvania brake operations, Moore⁽⁴⁵⁾ found that only one of 31 brake shops used compressed air. To estimate a base line exposure for our study, however, an uncontrolled brake repair operation (the brake drums were dropped on the floor to displace the dust) was sampled. The measured asbestos exposure as determined by PCM and TEM for the uncontrolled method was comparable to the five major control methods. Although the mechanic's exposure was low, there is a potential for build-up of asbestos contamination in the garage. Furthermore, neither the brake drum nor the brake assembly was cleaned as well as desired. Because the uncontrolled procedure was measured for only one vehicle, no statistical comparison was made between the results for this method and the five control methods evaluated.

6.1.3. Comparison to Indoor and Outdoor Ambient Levels

Personal sample concentrations during brake repair were significantly higher than indoor background levels as determined by PCM ($p < 0.03$) and TEM ($p = 0.005$) when using the aerosol spray method; personal sample concentrations (TEM) were higher than indoor background levels when using vacuum enclosure B ($p = 0.06$). Personal sample concentrations during brake repair for the other controls methods were not statistically different than indoor background levels based on both PCM and TEM results. Asbestos, as determined by TEM, was detected on only 25 percent of the outdoor ambient samples; thus, no statistical comparison to indoor background concentrations could be made. However, average outdoor and indoor ambient asbestos concentration measurements were about the same.

6.1.4. Effect of Vehicle Type, Drum Size, and Number of Drum Brakes

Most of the vehicles evaluated in the study were automobiles and light trucks with 8- to 12-inch drum sizes; however, two large vehicles with 16- to 17-inch drums were also evaluated. Personal sample concentrations during brake service to the latter, as determined by PCM, were at or below the detection limit (0.004 f/cc) as were most of the personal sample concentrations (PCM) during brake service to the smaller vehicles. Although there was no difference based on PCM measurements between large vehicles and small and medium size vehicles, asbestos exposures as determined by TEM during brake service to the large vehicles were an order of magnitude greater than during brake service to vehicles with smaller drum sizes. Larger brake shoe surfaces and drums probably contain more residual dust and provide a much greater source of asbestos emissions. In addition, the drum assembly of the large salt truck was so large and difficult to remove that the vacuum enclosure A could not be placed over it until the drum was removed.

Statistical analysis of TEM data showed that when using the aerosol spray method, the average personal sample concentration for brake repair of the large boom truck was significantly higher than the highest exposure during brake repair of the other vehicles ($p < 0.01$); but for vacuum enclosure A, the exposure during brake repair of the large vehicle was not shown to be statistically different than that for the smaller vehicles. Except for the effect of drum size, differences in personal and source sample concentrations due to vehicle model, miles traveled, number of drums per vehicle, etc., were small.

6.2. CONTROL METHOD DESIGN STRENGTHS AND WEAKNESSES

6.2.1. Vacuum Enclosures

The two vacuum enclosures evaluated surround the brake assembly during cleaning. The front of the enclosures protect the brake mechanic, even if the seals around the axle at the back are not tight. The enclosures allow the use of compressed air for more thorough cleaning; however, if the seals are not tight, asbestos can be blown into the shop and create a general room hazard. Work practices which may affect worker dust exposure are: (1) use of the pressurized air hose may force open the vacuum enclosure seal in the back and release airborne dust from the chamber; (2) incomplete air washing and vacuuming of brake dust; (3) dust trapped behind brake components may become airborne during change and replacement; and (4) poor maintenance of the vacuum enclosure unit (e.g., not changing filters regularly and incomplete cleaning of chamber.).

Vacuum enclosure A was large enough to accommodate the entire brake assembly of most of the vehicles while removing the drum. The axle source sample concentrations (TEM) for cars, pickup trucks, and vans were all less than 0.03 f/cc, indicating that brake dust was not blown out the back flaps. Vacuum enclosure B, a smaller unit, fit around the brake assembly only after the drum was removed, and did not form a tight seal. As a result, both personal and

area (fender and axle) asbestos concentrations (TEM) were slightly higher for enclosure B than for enclosure A.

Vacuum enclosure A has a large clear plastic enclosure which provides good visibility. Tools, such as a hammer, can be placed inside the enclosure before starting the brake job. The two glove entry ports make it possible to do more tasks in the enclosure. This enclosure could not be used while removing the drums of the large vehicles (drum size >15 inches) for two reasons: (1) the drum is an integral part of the wheel and must be removed with the wheel, and (2) the drum is so large and heavy that the mechanic cannot remove the drum while inside the hood.

An advantage of using vacuum enclosure A is that it is under negative pressure while the vacuum is running and, thus, the potential for airborne asbestos to leak from the chamber is reduced. However, workers need to be trained to operate and maintain the vacuum enclosure unit or they may increase their personal exposure to brake asbestos through poor work practices, e.g., improper use of the compressed air hose may force open the seal around the axle and blow dust out of the unit. Workers stated that brake cleaner fluid was sometimes applied to the brake parts to suppress brake dust after taking the vacuum enclosure unit off the brake housing.

Brake inspection took approximately 16 minutes and brake inspection and replacement took 25 minutes per wheel. A minute or two of this time was required to roll out either vacuum enclosure and put it in place. After 4 months of operation, averaging four brakes inspections or replacements per week, the vacuum filter was found to be about half full.

From an ergonomic point of view, vacuum enclosure A is somewhat cumbersome to use and maintain. It is too big in some instances to be easily maneuvered between cars; the height of the base does not permit the unit to be used as close to the floor as would be desirable, especially for large trucks; the inside of the plastic dome is hard to clean and the outside is prone to scratches and smears, which may impair visibility; there are no brackets or other provisions to conveniently store the vacuum hose after use. (Based on a recommendation from our survey, a hook was fabricated to keep the hose off the floor and in good repair.) It was also noted that design of the gloves, especially at the wrists, may restrict workers who have large muscular hands from being properly fitted into the gloves. However, the workers thought that the vacuum filter was effective.

With vacuum enclosure B, it was necessary to remove the brake drum from the vehicle before the enclosure could be applied to the brake assembly. The rubber seal at the back of the encapsulation cylinder was poorly designed because it was easily deflected by the compressed air stream. The brake components inside of the cylinder were poorly illuminated. It was difficult to change the gloves to accommodate size and glove hand (left or right). The vacuum unit was bulky; this made it difficult to maneuver and use in tight work spaces.

In addition, workers felt this unit was heavier than a vacuum enclosure device they had used previously. Asbestos concentrations as high as 0.164 f/cc (TEM) for the axle sample is indicative of brake dust escaping during air washing when the air gun is pointed at the enclosure seal in the back of the enclosure. (The manufacturer has recently changed the iris seal to one constructed with overlapping panels.)

6.2.2. Vacuum Only

The HEPA-filter equipped vacuum unit substantially controlled asbestos exposures; the personal exposure concentrations averaged 0.007 f/cc as determined by PCM, and 0.022 f/cc as determined by TEM. This unit is not limited by drum size and can be used at any stage of the brake maintenance operation. This control method eliminates the need to dispose of a liquid residual that wet methods require; however, the unit does require periodic maintenance, including replacement of the HEPA filter.

The HEPA-filter equipped vacuum unit does not provide for the use of compressed air and may result in less thorough cleaning than with the enclosure method. The relatively low axle and fender asbestos concentrations as determined by TEM indicate that little force (compared to compressed air or the pressurized wet spraying) is applied in vacuuming the drum. The highest fender or axle concentration (TEM) was 0.020 f/cc.

The vacuum unit with the HEPA filter was effective for small and medium size vehicles, but it was not evaluated on large vehicles. It may be a suitable control when replacing brakes for such vehicles (because no enclosure is used, the control is not limited by wheel size). Additional research on larger vehicles is needed.

This unit appeared to be easy to use and effective for dust control from an ergonomic point of view. However, the effectiveness of the unit as a control is likely to vary with the work practice used and, as was previously discussed, may vary with the size of the vehicle. One work practice which increased the contact with asbestos fibers (fibers which can become airborne and enter the breathing zone) occurred when, after the disassembly, small parts (springs, screws, etc.) were hand held to vacuum them. Another practice observed to increase the dust levels occurred when the mechanic wiped his hands with a dry rag.

6.2.3. Wet Brush/Recycle

Low personal exposures and fender and axle concentrations as determined by TEM showed that the wet brush/recycle unit controlled asbestos exposures. No asbestos fibers (as determined by TEM) were found on any of the personal samples. Regular changing of the cleaning solution is needed for maximum effectiveness. Since there is no control during drum removal (such as an enclosure), the mechanic should allow cleansing fluid to flow between the brake drum and brake support plate before the drum is removed. After the brake drum is removed, the wheel hub and the back of the brake assembly should be

thoroughly wetted to suppress dust. The brake support plate, brake shoes, and brake components used to attach the brake shoes also should be thoroughly washed before the operator starts to remove the old shoes.

The wet brush/recycle control method was evaluated only on jeeps which had drum sizes of 9 to 11 inches; however, these vehicles had drum brakes on all four wheels. Higher asbestos exposure may occur during brake inspection and repair to vehicles with larger drum sizes when using this control method; further research on large vehicles is needed.

6.2.4. Aerosol Spray

The aerosol spray method showed that asbestos exposures, based on breathing zone samples (TEM), were well controlled; however, fender concentrations as high as 0.166 f/cc (TEM) indicate that asbestos fibers are being released during the brake job. Holding the spray can too close to the brake assembly while spraying could increase asbestos emissions. The following technique appeared to lower dust exposures: Spraying was started about 18 inches from the brake surfaces. After the surfaces were wetted, the nozzle was moved to about 12 inches from the surfaces to clean them. The brake components were individually sprayed as they were being removed. For this method to be successful, the mechanic needs to be trained in the least hazardous aerosol spray application technique. The solution used for the aerosol spray must be carefully selected to ensure that hazardous exposures from solvents or other ingredients do not occur.

The average time for a one wheel brake replacement task while using the aerosol spray unit was 30 to 40 minutes. The spray tip of the applicator needs to be maintained to provide a fine spray from the nozzle as opposed to a spray jet which blasts upon the brake assembly surfaces.

TEM personal sample results (Table 5-7 and Figure 5-4) were substantially higher using the aerosol spray method on a vehicle having 16.5-inch brake drums (a tandem wheel vehicle) than for vehicles having smaller brake drums (≤ 12 inches in diameter), indicating that the wet spray was not as effective on the large vehicle. Not only is the brake surface area greater, resulting in a greater amount of brake dust that needs to be controlled, but the wheel well area is larger making the area to be sprayed less accessible. The wheel well acts as a partial enclosure which captures the airborne dust and mist generated during spraying. In order to reach the parts and to observe the cleaning operation, the mechanic must place his head within the wheel well. As a result, the exposure to higher concentrations of asbestos dust were encountered than when a smaller vehicle is serviced.

6.3. RECOMMENDATIONS OF REGULATORY AGENCIES

6.3.1. Occupational Safety and Health Administration

OSHA guidelines, presented in Appendix F of CFR 1910.1001,⁽⁴⁶⁾ recommend the use of the vacuum enclosure, compressed air/solvent system, and the aerosol

spray (squirt bottle or nonrefillable spray can) methods. Because they operate at lower pressures, OSHA indicates that squirt bottles or spray cans are preferable to the compressed air/solvent system. Dry and wet brushing methods are considered by OSHA to be "ineffective." The use of compressed air to blow the brake drums clean is specifically prohibited by OSHA.

The results of our study demonstrate that when the vacuum enclosure and aerosol spray method were used correctly, the mechanics' exposure to asbestos was well below the OSHA PEL and NIOSH REL. The compressed air/solvent system was not evaluated. Two other techniques studied also showed low exposures for the mechanics: a vacuum only unit with HEPA filter and wet brush/recycle with recirculating solution.

The wet brush/recycle technique observed in our study (a brush continuously flooded with a solution of water and a co-solvent) successfully controlled asbestos exposures. Unlike the ineffective simple brush methods cited by OSHA, the liquid was apparently delivered to the brush at a volumetric flow sufficient to wet the dust without rendering it airborne.

The HEPA-filter equipped vacuum was used with a metal crevice tool to remove dust from the brake drum after it was removed from the brake assembly, to clean up brake dust that falls to the floor during drum removal, to clean the brake components before the removal of the brake shoes, and to clean components again as they are removed.

A simple wet brush method evaluated on a single vehicle resulted in low exposure to the worker. However, because this result was obtained from a single evaluation, it is difficult to ascertain the appropriateness of this method. Manual wet brushing may be an effective control measure, depending on the skill of the worker (gentle application of an adequate quantity of solvent to thoroughly wet the brake dust).

6.3.2. U.S. Environmental Protection Agency

"Guidance for Preventing Asbestos Disease Among Auto Mechanics,"⁽⁴⁷⁾ a publication of the U.S. Environmental Protection Agency, suggests the following methods contribute to worker exposure to asbestos: dry rag or brush, wet rag or brush, squirt bottles or aerosol spray, solvent recirculation systems, garden hose, and simple shop vacuum cleaners. This publication suggests that the best control approach is to contain brake dust and prevent its release into the work environment; it recommends the use of vacuum enclosure equipment.

The results of our study essentially confirm the performance of the vacuum enclosure method recommended by the U.S. EPA. Our study also indicates that the wet brush with circulating solvent and the aerosol spray methods are effective: background asbestos measurements were no higher in garages using the wet methods than in garages using the vacuum enclosures. All the garages studied using wet methods used care so that all liquid residue was collected in catch basins, which were emptied before the solvent was allowed to evaporate. Low asbestos exposures were also measured when a single brake inspection was

made using a garden hose and a wet brush. Dry rag or brush methods and use of the simple shop vacuum cleaner (without a HEPA filter) were not evaluated in our study.

6.4. REAL-TIME SAMPLING

The NIOSH air sampling methods for asbestos provide an integrated average exposure over the sampling period (2 hours), whereas, real-time sampling data provides short-term exposures (1 minute) due to various job tasks. The real-time data obtained from the HAM instrument are a measure of the respirable dust concentration and are not specific for asbestos. However, correlation of real-time results with the phases of brake maintenance is a starting point for identifying brake maintenance job tasks which produce increased asbestos exposures. Comparison of the relative dust concentrations produced by individual job tasks can be used to assist in the determination of the relative effectiveness of the brake dust control methods.

The control methods evaluated could be applied to four of six identified phases of brake maintenance: drum removal, drum and brake assembly cleaning, parts removal, and installation of the parts and drum. None of the control methods were applicable during the removal and remounting of the wheel and tire; however, most of the dust generated by these tasks was assumed to be from dirt and road dust containing minimal amounts of asbestos. These dust concentrations could probably be reduced by running the vehicle through a car wash before brake maintenance was initiated.

Overall, all methods controlled dust release to relatively low average and peak concentrations. During brake drum removal, real-time data indicated that enclosure A provided the best control. This was especially true when the drums were difficult to remove and required hammering and prying to release them. The wet brush/recycle method showed slightly higher dust generation during this phase; dust control may be improved if cleaning solution is allowed to flow between the backing plate and the drum before the latter was removed. All methods controlled dust release to relatively low average and peak dust concentrations during brake cleaning, parts removal, and reinstallation.

6.5. WORK PRACTICES AND HYGIENE

Mechanics should assume that all brake shoes being removed are asbestos-type shoes. Worn nonasbestos-type brake shoes cannot be readily distinguished from asbestos-type shoes. If the mechanic makes an erroneous assumption that a shoe is of the nonasbestos-type shoe and relaxes his normal brake dust control procedures, increased asbestos exposure may result.

The operator must be trained in the correct and most effective way to use the control system selected. The danger of improper work practices which can increase the worker's potential exposure to asbestos should be explained. Some examples are: directing an air nozzle at an enclosure seal, placing the nozzle of a spray mist too close to the work surface, not placing the vacuum nozzle close enough to the contaminated surface, turning on the vacuum pumps before

positioning the vacuum enclosure over the wheel and leaving them on when removing the enclosure, splashing or spilling brake dust contaminated solutions on the floor. The control device should always be used and consistent work procedures should be followed.

Any spills of brake dust or contaminated solutions containing brake dust should be cleaned up immediately by either vacuuming or wet mopping. For difficult-to-remove drums that require hammering to loosen, a pan with a little water in it could be placed beneath the wheel to catch the falling brake dust.

Vacuum enclosure units should be large enough that the brake drum can be removed while the drum is enclosed and should be large enough to allow for hammering when brake drums are difficult to remove because of wear, rust, or other reasons. (If drums are too difficult to remove within an enclosure, the vacuum nozzle should be positioned beneath the brake drum to capture dust and dirt that falls from it.) Enclosure-type systems should have good interior lighting to illuminate the work area. The seal should completely enclose the brake drum and backing plate and provide a tight seal around the axle. The mechanic should not direct the air gun at the seal. After cleaning with compressed air, the inside surfaces of the enclosure should be vacuumed to keep the inside clean and maintain visibility. Each brake component should be vacuumed as it is removed and the backing plate should be vacuumed after all the components have been removed. If a rag is used to wipe dry or clean used brake parts, the mechanic should not use this same rag to wipe his hands. Wiping of hands with a dry rag was observed to increase dust concentrations in the mechanics breathing zone. Water and a suitable soap or detergent should be used to clean the hands. Operators should wear a NIOSH/MSHA-approved respirator when changing filters on vacuum units.

When using the wet brush/recycle method, the wheel hub and back of the brake assembly should be wetted before removing the drum. The fluid should be allowed to flow between the backing plate and the inside of the drum to thoroughly wash the backing plate and drum. After the drum is removed, the wet brush should be used to wash the components being removed. The brake washer solution should be changed regularly for maximum efficiency of the unit. Respirators or other personal protective equipment may be required when adding the cleaning or wetting agent to the water. The manufacturer's recommendations should be followed.

The aerosol spray method requires only a small piece of equipment, however, correct work practices are essential. If the the spray nozzle is held too close to the brake surface, asbestos fibers can become airborne. Brake components should be sprayed to saturate the parts as they are removed from the assembly. The spray nozzle should be maintained so as to provide a fine spray, rather than a jet or stream of liquid.

A regular maintenance program for the device used to control brake dust should be instituted. It should include checking and replacing seals, nozzles, other hardware, and contaminated filters and solutions. The deficiencies of any control system, such as ineffective seals, and the effects due to sprays and

air nozzles should be well understood. Disposal of asbestos-contaminated material, whether it be filters or solutions, should be done in accordance with federal and state regulations. Periodic cleaning should be performed to remove asbestos contamination of work benches, floors, etc.

Mechanics should not eat, drink, or smoke in work areas. Asbestos and other potentially toxic materials can be ingested by these actions.

Personal hygiene, such as washing hands frequently and showering at work before going home, should be stressed. Changing from soiled work clothes into uncontaminated street clothing before leaving work provides additional protection against bringing asbestos into the home environment. A laundry service with facilities for cleaning asbestos-contaminated clothing should be provided for the soiled work clothes.

When selecting a control system, two factors to consider are time and convenience. Some systems add several minutes to each brake job, thus a mechanic that is paid for each job completed is less likely to use such a system correctly, if at all. Similarly, if the system is awkward or cumbersome, it is less likely to be used in an effective manner.

6.6. FIBER SIZE AND POTENTIAL HEALTH EFFECTS



In this study, a total fiber count (including fibers not identified as asbestos) was obtained by pooling all the personal samples from each of the five major controls. The results of this pooling are presented in Figure 6-2. The majority of these fibers are less than $0.1 \mu\text{m}$ in diameter and less than $4 \mu\text{m}$ in length.

The potential health impact of the fibers present in brake dust is not completely understood. However, Stanton⁽²⁵⁾ attempted to estimate the tumorigenic potential in humans according to a fiber diameter and length matrix. Stanton noted that long, thin fibers produced the greatest tumorigenic incidence in experimental animals. A plot of the fiber sizes measured in this study is presented along with an overlay of Stanton's classification based on his animal studies in Figure 6-2. About 1 percent of the fibers in the samples from our study fit the classification of moderate and high tumorigenic potential. Pott⁽⁴⁸⁾ has summarized other studies concerning the carcinogenic potency of asbestos fibers. These studies indicate tumor induction extends to fibers shorter in length than those given by Stanton. Pott also notes that although the carcinogenic potential of short fibers may be low, many short fibers may induce a tumor as easily as a few long fibers.

COMPOSITE (ALL CONTROLS)

PERCENTAGE OF TOTAL FIBERS

DIAMETER (um)	FIBER LENGTH (um)				
	>0.2 - 1	>1 - 4	>4 - 8	>8 - 64	>64
<0.1	30%	26	2	<1	0
>0.1 - 0.25	8	11	<1	<1	0
>0.25 - 0.5	1	12	<1	<1	0
>0.5 - 1.5	0	3	2	<1	0
>1.5 - 2.5	0	0	0	<1	<1

-  LOW TUMOR RATE IN ANIMALS *
-  MODERATE TUMOR RATE IN ANIMALS
-  HIGH TUMOR RATE IN ANIMALS

* (Stanton, Ref 25)

Figure 6-2. Fiber size distribution for all personal samples.

7. CONCLUSIONS/RECOMMENDATIONS

7.1. CONCLUSIONS

All of the five methods tested, in combination with the work practices used, controlled the mechanic's asbestos exposure during brake servicing to less than 20 percent of the NIOSH REL and 10 percent of the OSHA PEL. Personal exposures, as determined by PCM, were at least an order of magnitude lower than personal exposures reported in the literature for brake service operations involving compressed air, dry brush, or wet brush cleaning.⁽³⁾ In the present study, brake mechanics were exposed to concentrations ranging from less than 0.004 f/cc to 0.016 f/cc (counting rules 7400B) for 2-hour sampling periods; the highest exposure was below the NIOSH REL of 0.1 f/cc and less than one-tenth the OSHA PEL of 0.2 f/cc. As long as compressed air cleaning, dry/wet brushing, or vacuum cleaners without HEPA filters are not used, it appears that even simple control measures suffice. Sites and methods used in historical studies appeared to be similar to those used in the present study.

The results of the present study generally support OSHA Guidance for automotive brake repair operations.⁽⁴⁶⁾ In particular, the use of the two engineering control methods - vacuum enclosure methods and the aerosol spray (squirt bottle) - that were recommended by OSHA resulted in low personal exposures, as determined by PCM and TEM analyses. However, the present study found the vacuum only unit with HEPA filter and wet brush/recycle with recirculating solution methods also showed low personal exposures for the mechanics. These latter two methods were not mentioned in the OSHA Guidance.

Brake mechanics are exposed to average concentrations of asbestos fibers ranging from less than 0.013 f/cc to 0.052 f/cc (by TEM) for the controls used in the present study (excluding two vehicles with 16- to 17-inch drum sizes). Results obtained by TEM include asbestos fibers of all sizes. Although TEM results are higher than PCM results, because of the greater sensitivity, both analytical methods yield ranges of results well below the OSHA PEL for small and medium size vehicles such as automobiles and light trucks.

Brake service to two heavy duty trucks (two 16- to 17-inch drum size) showed higher asbestos concentrations than for smaller size vehicles as determined by TEM. The large trucks had greater brake shoe surface area and bulkier drums. Also, controls, such as the vacuum enclosures observed in our study, could be applied for fewer brake service tasks. Although mechanics were exposed to levels of asbestos fibers well below the NIOSH recommended exposure limit for asbestos as determined by PCM, the TEM results may indicate that a greater potential exists for asbestos exposure while servicing heavy duty trucks.

Except for the effect of drum size, differences in personal and source sample concentrations (as determined by TEM) among the vehicles evaluated were very small. Differences with respect to mileage, vehicle model, year of manufacture, etc., were not observed.

Vacuum enclosure units are the only type that provide for containment of the brake assembly during drum removal. These enclosures come in a variety of sizes which limit their use to certain brake drum sizes. Vacuum enclosure A was large enough to allow the drums of autos, vans, and pickups to be removed and replaced within the enclosure, and the enclosure therefore helped contain asbestos emissions during these tasks. The two-glove vacuum enclosures (Enclosure A) are superior for difficult-to-remove drums, because a hammer and other tools can be manipulated within the enclosure.

Compressed air can be used in the vacuum enclosures to remove brake dust adhering to the brake components and the shoes. However, when it is pointed at the back of the enclosure, the compressed air blast may be strong enough to deflect some seals, resulting in the escape of brake dust through the seals. Vacuum enclosure manufacturers could incorporate a means to regulate the air pressure in compressed air cleaning hoses. Because brake dust is usually collected dry, vacuum enclosures present a potential problem of asbestos exposure during the maintenance of the enclosure and the replacement of the vacuum filters. Vacuum enclosures were readily used and well accepted by the mechanics observed in this study; but their use did add several extra minutes to the time needed to complete a brake job. A hook for hanging the power cord was designed and added to vacuum enclosure A as a result of our survey. This hook was very beneficial, according to mechanics on a follow-up visit. The need to illuminate the inside of both vacuum enclosure units was noted.

HEPA-filter equipped vacuum cleaners can be used on brakes of any size. These systems do not use compressed air, nor do they generate dust that must be contained as do the vacuum enclosure systems. However, the drums must be removed before the vacuum cleaner can be used; thus, there is a potential for asbestos release during drum removal. They do not clean the brake components as effectively as some other systems and require small vacuum nozzles to reach smaller parts of the brake assembly.

The wet brush/recycle system can be used on all sizes of brake drums. Limited wetting of the brakes can be accomplished with the drum in place. Dust that otherwise would have fallen to the floor is wetted and collected in the catch basin beneath the wheel. This may provide better control when difficult-to-remove drums are encountered. The low velocity delivery of the wet brush/recycle fluid effectively cleans the brake components. The contaminated fluid provides a dust free, though bulkier method of disposal.

The principal advantages of aerosol spray systems are low cost and the capability for use on all sizes of brake drums. Care must be taken initially to ensure that the sprayer is at a proper distance from the brake to wet the brake surfaces, but vigorous spraying must be prevented so that dust will not be re-suspended. The effectiveness of the solvent spray systems as an exposure

control method appears to be more dependent on work practices than the other techniques. In some cases, the solvent may contain potentially hazardous component(s).

The asbestos exposure for the uncontrolled method (the brake drums were dropped on the floor to displace the dust) was comparable to the five major control methods. Although the mechanic's exposure was low, there is a potential for build-up of asbestos contamination in the garage. Furthermore, neither the brake drum nor the brake assembly was cleaned as well as desired.

Although PCM exposure data in our study can be compared to the OSHA PEL, NIOSH REL, and historic exposure results; only TEM results provide for fiber identification and allow comparisons between vehicle types, drum sizes, control methods, and between personal sample concentrations and ambient or indoor asbestos concentrations. This is of particular importance in brake servicing, since most fibers are too small to be measured and counted by PCM.

Fiber size distribution for all fibers, including those not identified as asbestos, showed that only 4 percent of the fibers measured during brake service would have been counted using PCM. Furthermore, 90 percent of the fibers identified by TEM had an aspect ratio of 5:1 or greater.

Fibers in dust samples obtained from the brake drums of 40 of the 43 vehicles tested in this study were mostly chrysotile fibers. The other three vehicles appeared to have nonasbestos-type brake shoes.

7.2. RECOMMENDATIONS

7.2.1. Engineering Controls and Work Practices

Engineering controls and good work practices should be implemented at all times during brake servicing. Because of the health hazards associated with asbestos exposure, these actions are warranted even when the worker believes that the brake shoes do not contain asbestos.

Several types of control systems or methods can effectively reduce exposure to asbestos during brake servicing. When selecting a particular type of control system or method, the employer should consider the number and types of brakes jobs to be performed daily and weekly. If the system or method selected is awkward or cumbersome to use, it is less likely to be used in an effective manner.

Several control systems, methods, and work practices observed in this study can be effective in reducing exposures if the following precautionary steps are followed:

- Enclosure-type systems should fit completely around the brake drum and backing plate and should provide a tight seal around the axle. The system should have good interior lighting to illuminate the work area. The inside of the enclosure should be large enough for the worker to

manipulate any tools that may be needed when brake drums are difficult to remove because of wear, rust, etc. The vacuum should be turned on before positioning the enclosure over the wheel, and it should remain left on while removing the enclosure.

- For wet brush/recycle methods, the wheel hub and back of the brake assembly should be wetted before the drum is removed. The fluid should be allowed to flow between the backing plate and the inside of the drum to thoroughly wash the backing plate and drum. After the drum is removed, all components should be washed and cleaned with the brush.
- The aerosol spray method is relatively small and easy to use; however, the spray nozzle must not be held close to the brake surface to avoid the airborne dispersal of asbestos.
- When using vacuum systems, each brake component should be vacuumed as it is removed. Once all the components have been removed, the backing plate should be vacuumed.
- For drums that are difficult to remove and require hammering to loosen, a pan filled with water should be placed beneath the wheel to catch the falling brake dust.
- A regular maintenance program should be instituted for the device used to control brake dust.

7.2.2. Training and Education

Information about job hazards should be disseminated through a training program that describes how to do a task properly, how each work practice reduces potential exposure, and how the worker benefits from such a practice. Workers who can recognize hazards and know how to control them are better equipped to protect themselves from unnecessary exposure. Training and work practices must be frequently reinforced.

Regardless of which control system is selected, the worker must be trained in the correct and most effective way to use it. Workers should be discouraged from using the following practices since they often increase the risk of accidental exposure to brake dust:

- Directing an air nozzle at an enclosure seal
- Placing the nozzle of a spray mist too close to the work surface
- Placing the vacuum nozzle too far from the contaminated surface to effectively collect all loose dust
- Spilling brake dust or contaminated solutions on the floor

7.2.3. Sanitation

Workers should not eat, drink, or smoke in work areas. Asbestos and other potentially toxic substances can be ingested by these actions.

The employer should provide hand-washing facilities and encourage workers to use them before eating, smoking, or leaving the work site. Workers should not wipe their hands with the same rag(s) used to wipe or clean brake parts, since this may release brake dust from the rag.

Any spills of brake dust or contaminated solutions containing brake dust should be cleaned up immediately by vacuuming or wet mopping. The work area should not be cleaned with dry sweeping or air hoses. Collected wastes should be placed in sealed containers with labels that indicate the contents. Cleanup and disposal should be conducted in a manner that prevents worker contact with wastes and complies with all applicable Federal, State, and local regulations.

7.2.4. Protective Clothing and Respiratory Protection

The employer should provide and require the use of work uniforms or overalls. Lockers or other closed areas should be provided to store work clothing separately from street clothing. All work clothing should be collected at the end of the work shift for laundering.

Respirators should be worn during specific work tasks (e.g., changing filters on vacuum units) or whenever the potential exists for airborne exposure to asbestos. Selecting the appropriate respirator depends on the specific contaminants and their concentration in the worker's breathing zone. Only a NIOSH/MSHA-approved respirator should be selected for use in accordance with the most recent edition of the NIOSH Respirator Decision Logic. When respirators are used, a complete respirator protection program should be instituted as set forth in 29 CFR* 1910.134.

* Code of Federal Regulations

8. REFERENCES

1. Dubrow, Robert and David Wegman. Setting Priorities for Occupational Cancer Research and Control: Synthesis of the Results of Occupational Disease Surveillance Studies. Journal of the National Cancer Institute. 71(6):1123-1142, 1983.
2. NIOSH. Survey Analysis and Supplemental Tables. National Occupational Hazard Survey. Vol. III. DHEW, PHS, CDC. DHEW (NIOSH) Publication No. 78-114. Cincinnati, OH. 1977.
3. Roberts, Dennis R. and R. D. Zumwalde. Asbestos Exposure Assessment for Brake Mechanics. DHHS, PHS, CDC, NIOSH. Industrywide Study Report 32.4. Cincinnati, OH. November 1982.
4. Keasbey and Mattison products catalog. Ambler, PA. 1926.
5. Carroll, W.G. The Manufacture of Brake Linings. British Plastics. 35:414-417, August 1962.
6. Anderson, A.E., R. L. Gealer, R. C. McCune, and J. W. Sprys. Asbestos Emissions from Brake Dynamometry Tests. Society of Automotive Engineers. Pub. No. 730549. Presented at Automotive Engineering Meeting. Detroit, MI. May 14-18, 1973.
7. White, Andrew J. Brake Dynamics: An Introduction to Brakes at the Inspection Station Level. Chapter 11, pp. 463-472. Motor Veh. Resh. of N.H. Lee, NH 1968.
8. Rohl, Arthur N., Arthur M. Longer, M. S. Wolff, and I. Weisman. Asbestos Exposure During Brake Lining Maintenance and Repair. Environmental Research 12:110-128, 1976.
9. Friction Materials on Automobile Brakes. Fleet Owner. August 1963.
10. PEI Associates, Inc. Asbestos Dust Control in Brake Maintenance. EPA Office of Pesticides and Toxic Substances. Contract No. 68-02-3976. 1985.
11. Williams, Ronald L. and Jean L. Muhlbaier. Asbestos Brake Emissions. Environmental Science Department, General Motors Research Laboratories, Warren, MI. Environmental Research 29:70-82, 1982.

12. Inoko, Masanori and Kyoko Arisso. Determination of Chrysotile Fibers in Residual Dust on Road Vehicle Brake Drums. Institute of Environmental Science and Technology, Yokohama National University, Yokohama, Japan. Environmental Pollution (Series B) 4:249-255, 1982.
13. Rohl, Arthur N. Letter dated April 11, 1979 from Dr. Rohl to Robert Magdelain, President, Nilfisk of America describing the results of tests run on the Nilfisk system. 1979.
14. Rohl, Arthur N. Letter dated October 12, 1984 from Dr. Rohl to Jim Clayton, President, Clayton Associates, Inc.; describing the results of tests run on the Clayton system. 1984.
15. Newhouse, M.L. and H. Thompson. Mesothelioma of Pleura and Peritoneum Following Exposure to Asbestos in the London Area. Brit. J. Ind. Med. 22:261-269, 1965.
16. McDonald, A.D. et al. Epidemiology of Primary Malignant Mesothelial Tumors in Canada. Cancer 26:914-19, 1970.
17. Greenberg, M. and T.A. Lloyd Davies. Mesothelioma Register 1967-1968 Brit. J. Ind. Med. 31:91-104, 1974.
18. Lorimer, W.V., A.N. Rohl, A. Miller, W.J., Nicholson and I.J. Selikoff. Asbestos Exposure in Brake Repair Workers in the United States. Mt. Sinai J. of Med. 43:207-218, May-June 1976.
19. Bader, M.E., R.A. Bader, A.S. Teirstein, A. Miller and I.J. Selikoff. Pulmonary Function and Radiographic Changes in 598 Workers with Varying Duration of Exposure to Asbestos. Mt. Sinai J. of Med. 38:492-500, 1970.
20. Davis, J.M.S. and S.W. Coniam. Experimental Studies on the Effects of Heated Chrysotile Asbestos and Automobile brake Lining Dust Injected into the Body Cavities of Mice, Experimental and Molecular Pathology. 19:339-353, 1973.
21. Koshi, K., H. Hayashi and H. Sakabe. Biological and Mineralogical Studies on Serpentine Minerals in Heat Treated State, Ind. Health, 7:66-85, 1969.
22. Pott, F., F. Huth and K.H. Friedrichs. Tumorigenic Effects of Fibrous Dusts in Experimental Animals. Environmental Health Perspectives. 9:313-315, 1974.
23. Pott, F., F. Huth and K.H. Friedrichs. Tumorigenic Effects of Fibrous Experiments Concerning the Carcinogenic Effects of Fibrous Dusts. Interpretation of Results Considering the Carcinogenesis in Humans. Annales d'Anatomie Pathologique, Paris. 21:237-246, 1976
24. Davis, J.M.G. The Fibrogenic Effects of Mineral Dusts Injected into the Pleural Cavity of Mice, British Journal Exp. Pathology. 53:190-201, 1972.

25. Stanton, M.F., M. Layard, A. Tegeris, E. Miller, M. May and E. Kent. The Carcinogenicity of Fibrous Glass: Pleural Response in the Rat in Relation to Fiber Dimension. J. Natl. Cancer Institute. 58:587-603, March 1977.
26. NIOSH. Criteria for a Recommended Standard, Occupational Exposure to 1,1,1-Trichloroethane (Methyl Chloroform). DHEW (NIOSH) Publication No. 76-184. Cincinnati, OH. 1976.
27. NIOSH. Registry of Toxic Effects of Chemical Substances. DHHS (NIOSH) Publ. No. 83-107. Cincinnati, OH. 1983.
28. NIOSH. Occupational Health Guidelines for Chemical Hazards. DHHS (NIOSH)/DOL Publ. No. 81-123. Cincinnati, OH. 1981.
29. USDOL, OSHA. Occupational Exposure to Asbestos, Tremolite, Anthophyllite, and Actinolite; Final Rules. 29 CFR 1910.1001 and 29 CFR 1926.58 Federal Register 51:22612. June 20, 1986.
30. USDOL, OSHA. Amendment to Occupational Exposure to Asbestos, Tremolite, Anthophyllite, and Actinolite; Final Rules. 29 CFR 1910.1001. Federal Register 53:35610. September 14, 1988.
31. NIOSH. Revised Recommended Asbestos Standard. U.S. Department of Health, Education, and Welfare. DHEW (NIOSH) Publ. No. 77-169. Cincinnati, OH. December 1976.
32. NIOSH. Statement of the National Institute for Occupational Safety and Health, the Public Hearing on Occupational Exposure to Asbestos, June 21, 1984. Testimony on Proposed Rule Making at OSHA Hearings. 1984.
33. NIOSH Method 7400. NIOSH Manual of Analytical Methods, Third Edition. DHHS, PHS, CDC. DHHS (NIOSH) Publ. No. 84-100 (Vol. 2). Cincinnati, OH. August 15, 1987.
34. Leidel, N. A., K. A. Busch, and J. R. Lynch. Occupational Exposure Sampling Strategy Manual. DHEW (NIOSH) Publication No. 77-173, 1977.
35. NIOSH Method 7402. NIOSH Manual of Analytical Methods, Third Edition. DHHS, PHS, CDC. DHHS (NIOSH) Publ. No. 84-100 (Vol. 2). Cincinnati, OH. August 15, 1987.
36. Burdett, Garry J. and Anthony P. Rood. Membrane-Filter, Direct-Transfer Technique for the Analysis of Asbestos Fibers or Other Inorganic Particles by Transmission Electron Microscopy. American Chemical Society. Environmental Science and Technology. 17(11):643-649, 1983.
37. Shtrom, E.: Personal Communication, PEI, Chester Road, Cincinnati, OH. January 28, 1988.

38. NIOSH. Quality Assurance and Laboratory Operations Manual. Revision 5, DPSE, Cincinnati, Ohio, August 1988.
39. Nilfisk of America, Inc. Product Information. Malvern, PA. 19355.
40. Cheng, V. K. I. and F. J. O'Kelly. Asbestos Exposure in the Motor Vehicle Repair and Servicing Industry in Hong Kong. J. Soc. Occup. Med. 36:104-106, 1986.
41. Rodelsperger, K., H. Jahn, B. Bruckel, J. Manke, R. Paur and H. J. Woitowitz: Asbestos Dust Exposure During Brake Repair. Am. J. Ind. Med. 10:63-72, 1986.
42. Kauppinen, T. and Korhonen. Exposure to Asbestos During Brake Maintenance of Automotive Vehicles by Different Methods. Am. Ind. Hyg. Assoc. J. 48(5):499-504, 1987.
43. Roberts, Dennis R. Industrial Hygiene Report Asbestos - Reading Brake and Alignment Service. DHHS, PHS, CDC, NIOSH. Industrywide Study Report 32.56. Cincinnati, OH. 1980.
44. Roberts, Dennis R. Industrial Hygiene Report Asbestos - Allied Brake Shop. DHHS, PHS, CDC, NIOSH. Industrywide Study Report 32.58. Cincinnati, Ohio. 1980.
45. Moore, L.L. Asbestos Exposure Associated with Automotive Brake Repair in Pennsylvania. Am. Ind. Hyg. Assoc. J. 49:A12-A13, January 1988.
46. USDOL, OSHA. Occupational Exposure to Asbestos, Tremolite, Anthophyllite, and Actinolite; Final Rules. 29 CFR 1910.1001 and 29 CFR 1926.58 Federal Register 51:22753-54, June 20, 1986.
47. USEPA. Guidance for Preventing Asbestos Disease Among Auto Mechanics. USEPA Publ. No. EPA-560-ODTS-86-002. Washington, DC. June, 1986.
48. Pott, F. Some Aspects on the Dosimetry of the Carcinogenic Potency of Asbestos and Other Fibrous Dusts. Staub-Reinhalt. Luft 38:486-490, 1978.

Appendix

Fiber Counts on Filter Blanks

Control	PCM		TEM	
	Number of Filters	Number of Fibers Detected	Number of Filters	Number of Fibers Detected
Vacuum enclosure A	12	0	10	2
Vacuum enclosure B	13	0	6	0
Vacuum only	7	0	7	1
Wet brush/recycle	12	0	6	0
Aerosol spray	7	0	5	0
Total	51	0	34	3

U S GOVERNMENT PRINTING OFFICE 1989-749-349/H5449