



HHS Public Access

Author manuscript

IEEE Trans Ind Appl. Author manuscript; available in PMC 2017 November 24.

Published in final edited form as:

IEEE Trans Ind Appl. 2017 ; 53(5): 5088–5095. doi:10.1109/TIA.2017.2703625.

Simulation and Measurement of Through-the-Earth, Extremely Low-Frequency Signals Using Copper-Clad Steel Ground Rods

Nicholas William Damiano,

Pittsburgh Mining Research Division, National Institute for Occupational Safety and Health,
Pittsburgh, PA 15236 USA

Lincan Yan,

Pittsburgh Mining Research Division, National Institute for Occupational Safety and Health,
Pittsburgh, PA 15236 USA

Bruce Whisner, and

Pittsburgh Mining Research Division, National Institute for Occupational Safety and Health,
Pittsburgh, PA 15236 USA

Chenming Zhou

Pittsburgh Mining Research Division, National Institute for Occupational Safety and Health,
Pittsburgh, PA 15236 USA

Abstract

The underground mining environment can greatly affect radio signal propagation. Understanding how the earth affects signal propagation is a key to evaluating communications systems used during a mine emergency. One type of communication system is through-the-earth, which can utilize extremely low frequencies (ELF). This paper presents the simulation and measurement results of recent National Institute for Occupational Safety and Health (NIOSH) research aimed at investigating current injection at ELF, and in particular, ground contact impedance. Measurements were taken at an outside surface testing location. The results obtained from modeling and measurement are characterized by electrode impedance, and the voltage received between two distant electrodes. This paper concludes with a discussion of design considerations found to affect low-frequency communication systems utilizing ground rods to inject a current into the earth.

Index Terms

Grounding; ground rods; low-frequency communications

Corresponding author: Nicholas William Damiano.

Paper 2016-MIC-0753.R1, presented at the 2016 Industry Applications Society Annual Meeting, Portland, OR, USA, Oct. 2–6, and approved for publication in the IEEE TRANSACTIONS ON INDUSTRY APPLICATIONS by the Mining Committee of the IEEE Industry Applications Society.

I. Introduction

The mine Improvement and New Emergency Response Act of 2006 (MINER Act) [1] mandated that every underground coal mine in the U.S. develop an emergency response plan within three years that includes two-way, postaccident, wireless communication and tracking. This plan must provide for communications between underground and surface personnel, and electronic tracking of all underground mine workers. A survey completed in 2014 showed that all active underground coal mines have installed a system that operates in the very high frequency or ultrahigh frequency bands [2].

Communication between personnel on the surface and miners underground is especially important during emergencies such as methane or coal dust explosions, belt fires, or entrapments from a large ground fall or pillar burst. In such circumstances, very high frequency or ultrahigh frequency band communication systems might be interrupted because their infrastructure may be damaged. Communication signals are subsequently blocked by the surrounding earth, attenuate on existing conductors once they have been damaged, or power is lost to critical parts of the system that prevents those signals from reaching the surface. One of the major benefits of extremely low-frequency (ELF) signals is that they can travel directly through the earth without the need for special infrastructure that may be susceptible to the type of damage experienced after a disaster unfolds.

In a situation where escape to the surface is cut off, trapped underground coal miners may enter a refuge alternative (RA). This RA has provisions for communications, lighting, sanitation, food, water, and first aid. The Mine Safety and Health Administration's final rule for RAs also states "Communications with the persons in RAs are vital to mine rescue efforts. The knowledge of where miners are in RAs, their condition, and the conditions in the mine may make the difference between life and death in a postaccident crisis." [3]. The RA typically achieves communication through a wired connection or the presence of a postaccident wireless communication system. However, it can be envisioned that—since an RA is designated as the last option—it is possible that this connection may be broken. The mine's communication system infrastructure can be susceptible to catastrophic damage caused by the previously mentioned events. Systems that do not utilize a large amount of infrastructure may be more likely to remain operational after a large accident.

ELF communications typically involves grounding to the earth using the lowest resistance path possible and injecting a current higher than 1 A. The ELF signals conduct through earth where they can be received by another ELF radio kilometers away. ELF systems can utilize a variety of different means to connect to ground, including power system ground beds, metal cased boreholes, rails, and any metallic support structure connected to earth [4].

There is currently one MINER Act compliant communication system which is designed to directly connect to earth [5]. This system is classified as a through-the-earth (TTE) system [6]. The system uses roof bolts to connect to the earth underground which is similar, in principle, to Fig. 1. There exist two other systems that are classified as TTE systems but do not operate in the ELF band—rather, they operate slightly above that in the very low,

ultralow, and super low frequency bands. These systems may also be able to utilize ground rods that directly connect to earth.

This paper explores the surface connection. The simulation and measurements completed investigate the current induced by the measurement system, which are then used to calculate ground impedance at the surface location.

II. ELF Communications

ELF covers a part of the electromagnetic spectrum from 3 to 30 Hz. This band is mainly used for submarine communication around the world. The permissible ELF system has low bandwidth and currently only supports a single channel for canned messages. Canned messages are messages where a single transmitted symbol represents a common word or group of words. Those symbols can then be used to transmit a common message such as “help me.” These limitations may make any permissible ELF system only useful during an emergency when all other means of communications have failed. An ELF system could provide an alternate path for communication from the underground to the surface that would possibly remain intact after a disaster. This system could be placed nearby an RA or other strategic location underground where miners are trapped.

On the surface, ELF systems can operate with very long antennas and utilize high-power transmissions. The very long antennas are capable of radiating power in the ELF system. Underground, however, the power used by these radios has to meet permissible requirements for U.S. underground coal mines, and extremely long antennas are not practical. Nonetheless, it has been observed that, by injecting a current directly into the ground, ELF signals can travel over 1 km provided the earth contact impedance and signal attenuation do not inhibit the system’s transmit signal. For ELF systems, the impedance the transceiver acquires once connected to ground plays a significant role in the performance of this system.

A basic ELF communication system consists of one ELF transceiver connected to two earth electrodes separated by a distance. In order to produce an ELF signal in earth, a potential difference must be generated between two earth electrodes. These electrodes may consist of several ground rods, some combination of grounded metal structure, or single rods in the simplest case. Current passing through the electrodes can generate a current in the earth. This current then propagates through the earth medium for some distance [7]. Another set of electrodes a distance away can detect the transmitted signal as a potential difference using the same principle of two electrodes. How far the signal can travel through earth depends on factors such as frequency, earth conductivity, transmitter and receiver antenna length, and transmitter current [8], [9]. It is known that received electrical field strength is proportional to the transmitter current, and thus, the transmitter current should be maximized to achieve a maximum transmission range. For a given source voltage, the transmitter current is mainly determined by the associated grounding impedance. This paper will focus on the grounding impedance and investigate how it is influenced by different controlling factors.

Ground impedance has been widely investigated for a variety of applications. For example, effective grounding systems are recommended by organizations such as IEEE and IEC to

ensure electrical safety [10]. Although it is not for communication purposes, an effective grounding system aiming for electrical safety protection also requires ground resistance to be minimum, varying from 10 Ω for lightning protection to below 0.1 Ω for many sites where protective devices with large fault currents are involved. In [10], several factors such as the number and length of ground rods are identified as parameters that can directly influence the ground impedance. Recently, Bataller *et al.* investigated electrode contact impedance under the context of TTE communications [10]–[12]. An earth impedance model that can be applied for TTE communications systems was proposed in [11]. In addition, a measurement method for characterizing the electrode impedance of a TTE communication system was presented in [12]. Electrode grounding impedance was also investigated in [13] to support cave radio research.

Earth conductivity σ is expressed in Siemens per meter. Due to variations within the earth, this value may change over distance. A multilayer model is more representative of the earth but it is challenging to predict. Earth can have many different layers such as clay, sandstone, and shale that vary in the moisture content, salt concentration, and soil temperature that affects resistivity [14]. Also, these layers have boundary zones where transitions between layers may or may not be abrupt. Furthermore, the surface of the earth provides a complex layer in which factors such as vegetation and terrain affect the makeup.

For earth contact impedance, one must consider the effects of connecting an electrode to lossy earth; earth is not a perfect conductor. There is an impedance associated with connecting an electrode to ground. Therefore, the conductivity used in simulation models was based on previous experimental findings. For conducting earth materials where the ratio of σ and the relative permittivity times the angular frequency ($\epsilon\omega$) is much greater than 1, this impedance is almost entirely real for these frequencies, and can be approximated with algebraic expressions [15], [16]. Ultimately, it is not possible to obtain a complete short at an electrode. The best that can be achieved is an approximation of a short to ground by providing $Z_r \ll Z_0$, where Z_r is the contact impedance between the electrode and earth and Z_0 is the characteristic impedance of the transmitter.

The transmitted signal has some attenuation rate and as long as the transmitted signal is large enough to overcome the attenuation rate, it can be seen by the receiver a distance away. For example, if the real part of the contact impedance is low (1 Ω) and the conductivity of earth is high (0.03 S/m), then the required current may not be very high (1 A) to generate a signal that may be detected several kilometers through the earth.

III. Analytical Model of Ground Impedance

For calculating the impedance of a ground rod in earth (Z_r), several models exist [17]. For this analysis, consider the following simplified contact electrode impedance formula taking into account four variables:

$$Z_r = \frac{1}{4\pi\sigma l} \ln \left[\left(\frac{4l}{a} \right) - 1 + \frac{1}{d} \right] \quad (1)$$

where

σ earth's conductivity (S/m);

l depth of the rods in earth;

a rod radius;

d separation distance between two vertical rods.

This formula does not take into account the frequency of the signal. It assumes a single rod for each electrode. It also does not take into account possible inductance and capacitance of the system, including the ground rod connection between earth and itself, which may have a complex component to its impedance [18]. For several other models, consideration has been given to complex values of the impedance. Variables used in this formula are depicted in Fig. 2.

IV. Numerical Simulation With FEKO

FEKO is an electromagnetic simulation software tool for the analysis of three-dimensional structures. FEKO utilizes multiple numerical methods for the solution of Maxwell's equations to solve electromagnetic problems. In this study, this software was used to simulate values of the impedance of the electrodes for comparison to field measurements.

ELF electrodes and transmitter were created (see Fig. 3) using FEKO to simulate various representative scenarios. These scenarios constitute a few simple considerations (e.g., depth and number of ground rods) in designing ELF electrodes that could be used to communicate through earth.

When comparing simulation results to measurement expectations of an ELF system, there are several factors to consider. Simulation will allow for imperfect connectors, separation distances, and different transmit and receive electrodes, but were not considered in this simulation. Certain factors such as terrain of the earth may affect alignment in a three-dimensional space; however, for the simulation, these were also not considered.

To begin to look at system impedance, a simple scenario of a single ground rod for two electrodes separated by 60 m was simulated. The two rods had a radius of about 7.9 mm each and the frequency was 20 Hz. In Fig. 4, analytical results were compared, although there was no consideration for frequency in the formula. Models were plotted as a function of rod depth. Impedance for both models is an exponential decay. It would appear that the two curves may converge but at depths exceeding 2.5 m.

V. Impedance Measurement System and Setup

The measurement system consisted of 12-V batteries, an audio amplifier, a calibrated passive current probe (model BCP-510 passive current probe from AH systems, Inc.), a voltage divider for measuring voltage, and a controller to collect data (see Fig. 5). This system was controlled using a computer and the data collected was stored on it. Two identical systems were assembled so that signals could be transmitted and received by

relatively identical setups. Measurements were taken sequentially over the period of a few weeks.

For the connection to ground, 1.58-cm diameter copper-clad steel ground rods were chosen for each electrode. These rods are standard for connecting residential power system grounds in the U.S. Ground rods were connected using 60-A charging clamps. Each clamp was crimped to a group of conductors consisting of insulated 10-gauge copper stranded wire to a central point. The central points of each electrode were connected to the amplifier's negative and positive outputs using a 60-m-long conductor of the same gauge wire. A block diagram is shown in Fig. 6.

The control board consisted of an analog output that generated a continuous sine wave using a 24-bit National Instruments analog output module model NI 9269. The signal being transmitted was monitored using an analog input (model NI 9239) connected to a current transformer. When current was not being transmitted, voltage could be read directly from the electrodes.

Measurements were taken in a surface test area (see Fig. 7) that had no other conductors within 100 m of the electrodes. The test area had gently rolling hills over much of the 365 m used for the experiment. The overall earth was slightly compact and dry to the touch for the testing areas. Vegetation consisted of tall grasses with trees throughout.

Experiments were conducted in the following three separate tests (see Fig. 8):

1. the ground contact impedance based on the number of ground rods per electrode;
2. the ground contact impedance based on the depth of ground rods;
3. the ground contact impedance based on the method of installation of the ground rods.

Test no. 1 varied the number of ground rods with fixed depth in each transmit electrode. Subsequent ground rods were driven into the earth separated in all directions by at least two times the rod depth, or 2.4 m each, in a square or rectangular pattern in order to reduce the influence caused by an adjacent rod [19].

Test no. 2 varied the depth of each ground rod with a fixed number of rods. Test no. 2 utilized only four ground rods, 4.8 m apart for each electrode. Ground rods were 2.4 m long and were all driven into the ground to the same depth at the same time. All transmit rods for test no. 2 began at 0.3 m deep and were incrementally driven another 0.3 m until they were 2.4 m deep. Measurements were taken at each increment.

Test no. 3 used 4 of the 16 rods from test no. 1 to compare to four newly installed rods of exactly the same length. Instead of directly driving these new ground rods into the earth as in all previous tests, these rods were installed by drilling into the earth first and removing any loose earth, leaving a 1.5-cm-diameter hole in the ground. A hammer drill and 1-m-long drill bit were used to make the hole. Once the hole was completely drilled out, a mixture of water and copper (II) sulfate, or CuSO_4 solution, was prepared. CuSO_4 is used in geophysical exploration to improve ground contact. CuSO_4 solution was poured into the hole several

times until it was completely saturated (the solution level remained visible near the surface for at least 15 min). Ground rods were then inserted into the holes saturated with solution and driven another 0.2 m. The rods were left alone for at least 24 h before testing began. All rods were driven into the ground, and for all tests, the rods were unable to be removed by hand, thus ensuring that some earth held on at least part of the rod. In the case of the rods treated with the CuSO_4 solution, all of them were still wet with solution 24 h later when testing commenced.

Each test was conducted in coordination with a similar measurement system 365 m away (see Fig. 9). This receive location consisted of the same hardware and setup except its electrodes were fixed in design for all tests. The receive location had two electrodes consisting of eight 1.2-m-long ground rods directly driven all the way into earth. Electrodes for the receive system were installed in rectangular formation and separated by 60 m. The ac voltage potential produced by the transmitter was measured at known intervals and recorded. Coordination between the transmitter and receiver systems was accomplished using handheld high-frequency radios. Both the transmitter and receiver systems were synchronized to record voltage and current at the same time.

VI. Simulation and Measurement Results

To arrive at an understanding of ELF electrode design factors, analytical calculations, computational electromagnetics software simulation, and field measurements were completed on the various test scenarios.

An ELF system has at least three sources of noise: 1) internal noise that the system generates itself; 2) external man-made noise; and 3) external natural noise coupling to the electrodes from the earth [20]. The wires connecting the receiving rods to the receiver can also pick up interference. When connected to earth, the ELF system detects voltage at that location induced by stray currents flowing in the earth created by chemical reactions, man-made sources, or thunderstorm activity. Since all three sources combine to form a noise floor, noise must be evaluated at the site at the time of installation.

Because interference from man-made frequency sources is inevitable, frequencies were chosen to be below or in between 60-Hz harmonics—a common source of interference at many sites in the U.S. Frequencies were selected that are not first or second harmonics of each other, so measurements of multiple frequencies could be recorded almost simultaneously without producing interference of their own.

A. Test no. 1—Electrode Impedance Based on the Number of Rods

The purpose of this test is to investigate how the TTE system's impedance varies by ground rod number per electrode. The ratio of the system's voltage divided by the current represents the magnitude of the system's impedance when connected to earth. It is important to note that the measured impedance using this method is the entire measurement system's impedance including both wire impedance and grounding impedance between rods. If the system was moved to another location, results may be different.

For this test, ground rods were directly driven into the ground using a hammer drill with a pounding bit. Choosing to start with more than one or two rods per electrode limited the effects of a single point of grounding, which may have contained anomalies if the immediate ground had a lot of rocks or tree roots present, but locations over 2.4 m away may not have such obstructions. The testing rod locations are shown in Fig. 10.

Frequencies selected for measurement were 20, 100, 330, 990, and 3030 Hz. These chosen frequencies cover a range above ELF to determine if there is any change based on frequency and to what degree that change could be. Results from these measurements are shown in Fig. 11.

Using FEKO, a similar setup was simulated, also varying the number of ground rods per electrode. An ideal amplifier was connected to electrodes with the same parameters as mentioned before. A sigma of 0.01-S/m was assumed in this case. Results from the FEKO simulation are shown in Fig. 12.

Comparing Figs. 11 and 12, there is some agreement between measurements and simulation, respectively. The impedance is inversely proportional to the number of rods. For measurement, there is a decrease in the magnitude of the impedance as frequency increases. For the simulation, there is a slight increase in the impedance with a rise in frequency. In FEKO, a very small inductance was found in the system, which increased the impedance presented to the transmitter at higher frequencies.

Measurement is less simple. The rods themselves and their connections to the earth will contribute to the overall impedance not present in the simulation. Isolating these variables was out of the scope for this study, so the results of all measurements in determining the impedance are the resulting magnitude of Z ($|Z|$).

B. Test no. 2—Impedance Based on the Depth of Rods Per Electrode

For this test, the purpose was to change only the depth of ground rods per each electrode on the TTE transmit system and determine the change in current generated in the system. The rods used for this test were incrementally driven into the earth with measurements taken at each increment. Results from the measurements are shown in Fig. 13.

In Fig. 13, the measurement starts out much higher in impedance before converging with the simulation at around 1.2 m. Similar to test no. 1, varying the frequency from 20 to 3000 Hz did not show a large change in the values of the simulation or measured impedance; there was less than a 5% change in value for frequencies up to 3000 Hz once rod depth exceeded 1.2 m.

C. Test no. 3—Impedance Based on the Installation Method

The standard way to install ground rods is by directly driving them into the ground, by using a sledgehammer or by using a hammer drill with a pounding bit. In most cases, a force is applied to the very top of the rod, driving it into earth. This is thought to have a positive effect on impedance, by compacting earth around the rod.

An alternate method of installing ground rods was also investigated, to see if this gave reduced contact resistance. In this method, a hole was drilled into earth less than the diameter of a ground rod to nearly the desired rod depth. Next, a solution of water and CuSO_4 was poured into the hole. This was repeated until the hole remained full to the surface of the earth for at least 15 min. Ground rods were then inserted into the hole forcing some solution out of the hole and onto the surface. The earth around the rods was still wet during testing and some solution was reapplied to each rod. These rods were installed 2.4 m away from rods directly driven into the ground for test no. 1. Results of three different measurements are shown in Fig. 14.

The first measurement was taken using just four rods per electrode of the rods directly driven into the ground for test no. 1. These were not the same rods used in test no. 1, but a different set of 4 from the remaining 16 directly driven into ground. When comparing the 4 rods to several other sets of 4 rods, a result of about 70Ω was found, agreeing with previous measurements.

Next, 2.4 m away, new holes were drilled and the rods were installed with CuSO_4 . It was thought that since the two sets of rods were relatively close, the ground impedance should be close. However, the rods with the CuSO_4 measured about half the impedance as the other rods. As a final measurement, one electrode was connected to each of the two types of rods. This result measured almost the same impedance as if both electrodes were directly driven, although one was not. This indicates that the contact resistance of both electrodes is the dominant factor in the contact resistance at this site, and the use of CuSO_4 solution can significantly reduce that impedance.

In order to determine if the results found during testing play a significant role in determining whether signal will propagate through earth, receive electrodes were monitored 365 m away from the transmit electrodes for all 3 tests.

As shown in Fig. 15, received signal increased several dBV with each incremental increase in the number of rods for most frequencies. For the lower frequencies (20 and 100 Hz), the results were less stable possibly due to the high noise floor detected at those frequencies. The noise level was the measured voltage when the system was not transmitting.

Received voltage for test numbers 2 and 3 was recorded and the same relationship was observed. As the impedance decreased, the received signal increased. The received voltage increased when the depth of the rods increased. For example, the received voltage during test no. 2 was -80.5 dBV for 1.2-m rods and increased to -71.2 dBV for 2.4-m rods for a frequency of 330 Hz.

The same relationship was observed for test no. 3. As the impedance decreased, increased signal was observed. When CuSO_4 was used, the receive signal increased. For example, the received voltage was -89.0 dBV for rods installed without CuSO_4 and increased to -80.8 dBV for rods with CuSO_4 for 330 Hz.

These results are thought to be due to decreased impedance at the transmit end 365 m away that allowed for a higher current to be injected into the earth. The noise level is the voltage

received while the transmit system is OFF. As expected, the measured impedance varies with location. The measured impedance at the receive side was about 14 Ω . This was significantly less than anything measured on the transmit side under nearly similar conditions.

VII. Conclusion

In a TTE system, the earth's conductivity will play a role in the signal transmitted, but this factor is out of the control of the user in most cases, unless the user is able to move to another location and try transmitting again.

In some underground situations, the amount of voltage available is limited due to permissibility concerns. Since the voltage is limited, the only parameter that may be changed is impedance. The simulation and measurement was conducted on the surface connection. However, the same method and system could be used to evaluate an underground connection at a specific location. It is also important to note that the calculated impedance is not the impedance between the surface and underground locations. This impedance is found by calculating the current flowing through earth between two electrodes.

In this paper, it was demonstrated that the overall impedance of the surface electrodes can be reduced by the following:

1. using multiple ground rods at each electrode;
2. increasing the depth of each ground rod;
3. using copper (II) sulfate solution.

Figs. 11, 13, and 14 show a progressive reduction in the measured impedance for all frequencies. Reducing the electrode impedance increases the current injected at a given voltage [21], which in turn may allow for longer communication distances. Fig. 15 shows that by increasing the current injected into the ground, the received voltage should increase. The increased voltage in the surface layer may allow for the signal to travel through subsequent earth layers, possibly reaching an underground location. The measurements presented in this paper can serve as a reference to help researchers understand some considerations for TTE system electrodes. Improving the design of the electrodes may allow for a better chance for surface personnel to send a signal to trapped miners and perhaps give them additional information they could use to escape.

Acknowledgments

The authors wish to thank Dr. J. A. Waynert for his contribution to the simulation and modeling of these experiments. The findings and conclusions in this report are those of the authors and do not necessarily represent the views of the National Institute for Occupational Safety and Health. Reference to specific brand names does not imply endorsement by the National Institute for Occupational Safety and Health.

Biographies



Nicholas William Damiano received the B.S. degree in electrical engineering from the University of Pittsburgh, Pittsburgh, PA, USA, in 2002.

He is currently an Electrical Engineer with the Pittsburgh Mining Research Division, National Institute for Occupational Safety and Health, Centers of Disease Control and Prevention, U.S. Department of Health and Human Services, Atlanta, GA, USA. He was at the Mine Safety and Health Administration as a Mine Electrical Accident Investigator. His research has addressed topics such as underground communication, tracking systems, and refuge alternatives.

Mr. Damiano is a Federal Acquisitions Institute certified Contract Officer's Representative monitoring contracts related to refuge alter natives.

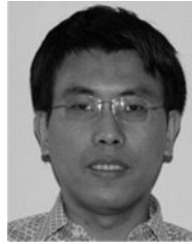

Lincan Yan received the B.S. degree in mining engineering from Northeastern University, Shenyang, China, in 1996; the M.E. degree in engineering mechanics from Tsinghua University, Beijing, China, in 2001; and the M.S. degree in mechanical engineering and the Ph.D. degree in electrical engineering from the University of New Mexico, Albuquerque, NM, USA, in 2003 and 2014, respectively.

He is a Research Scientist with the National Institute for Occupational Safety and Health, Pittsburgh, PA, USA. He is currently conducting research on heat transfer, structure design and failure, and through-the-earth communication for refuge alternatives.



Bruce Whisner is an Electronics Technician who served six years in the U.S. Navy, Orlando, FL, USA. He received two years of nuclear power training, and for four years, worked on avionics systems. He started working at Siemens/Robicon in 1997, working with large drive applications, printed circuit boards, and computerized numerical control machines for 13 years. He started working with the National Institute for Occupational Safety and Health, Pittsburgh, PA, USA, in 2010. He has worked on projects related to safer battery testing, proximity detection, medium-frequency propagation, and through-the-earth communication. He has automated data collection processes using LabVIEW.

Mr. Whisner received the Centers for Disease Control Employee of the Month Award in April and the Federal Executive Board Gold Award for Best Technician in 2012.



Chenming Zhou received the Ph.D. degree in electrical engineering from Tennessee Technological University, Cookeville, TN, USA, in 2008.

He is a Senior Research Engineer with the National Institute for Occupational Safety and Health (NIOSH), Centers for Disease Control and Prevention, U.S. Department of Health and Human Services, Atlanta, GA, USA. He served as the Project Leader and the Principal Investigator for the wireless communications and tracking project at NIOSH. He also serves as a government Contract Officer Representative for NIOSH Broad Agency Announcement contracts related to communications and tracking research.

Dr. Zhou is currently an Associate Editor of the IEEE ANTENNAS and PROPAGATION MAGAZINE.

References

1. MINER Act. 2006. [Online]. Available: <http://arlweb.msha.gov/Miner-Act/MinerActSingleSource.asp>
2. Damiano N, Homce G, Jacksha R. A review of underground coal mine emergency communications and tracking system installations. *Coal Age Mag.* Nov.2014 119:34–35. [Online]. Available: <http://coal.epubxp.com/i/421812/64>.

3. Mine Safety and Health Administration, 30 CFR Parts 7 and 75. Refuge alternatives for underground coal mines; Final rule. 2008. [Online]. Available: <http://arlweb.msha.gov/MinerAct/MinerActSingleSource.asp>
4. E-Spectrum Technologies. Broad Agency Announcement, Contract Final Rep. NIOSH; Pittsburgh, PA, USA: 2009. Ultra low frequency through-the-earth communication technology. Contract # 200-2008-26818
5. Burris, D., et al. Portable wireless through-the-earth communication system. US Patent. 0 076 178. Mar 29. 2012
6. MINER Act Compliant Communication & Tracking Systems and Peripherals. Mine Safety and Health Administration; 2016. p. 7[Online]. Available: <http://arlweb.msha.gov/techsupp/PEDLocating/CommoandTrackingMINERActCompliant.pdf>
7. Yan, L., Sunderman, C. Electric field of grounded horizontal line transmitter for through-the-earth communication. presented at the 31st Int. Review Progress Applied Computational Electromagnetics; Williams-burg, VA, USA. 2015.
8. Hill D, Wait J. Subsurface electromagnetic fields of a grounded cable of finite length. Can J Phys. Jul 15; 1973 51(14):1534–1540.
9. Yan, L., Zhou, C., Reyes, M., Whisner, B., Damiano, N. E-fields of electrode-based through-the-earth (TTE) communication. presented at the 51st IEEE Industry Applications Society's Annual Meeting; Portland, OR, USA. Oct. 2016
10. Earth grounding resistance. Fluke Corporation; Everett, WA, USA: Mar. 2014 [Online]. Available: http://ecmweb.com/site-files/ecmweb.com/files/uploads/2014/03/4346628a_en_EarthGround-tutorial-e.pdf
11. Bataller V, Muñoz A, Gaudó P Molina, Mediano A, Cuchí JA, Villarroel JL. Electrode contact impedance measurement in through-the-earth communications. J Radio Sci. Dec.2010 45(6) Art. no. RS6015. doi: 10.1029/2010RS004406
12. Bataller V, Muñoz A, Gaudó P Molina, Mediano A, Cuchí JA, Villarroel JL. Electrode impedance measurement in through-the-earth communication applications. IET Microw, Antennas Propag J. May; 2012 6(7):807–812. DOI: 10.1049/iet-map.2010.0312
13. Hey J. Practical measurements of earth-loop impedance. Cave Radio Electron Group J. Sep.2003 53:28–29.
14. Gomez, J. Proc 3rd ST Workshop Eur Org Nuclear Res. Chamonix; France: Jan. 2000 Design and calculation of an earth electrode; p. 25-28.Paper CERN-ST-2000-053
15. Tesche, FM., Ianoz, M., Karlsson, T. EMC Analysis Methods and Computational Models. Hoboken, NJ, USA: Wiley; 1996.
16. King, RL., Hill, HW., Jr, Bafanna, RR., Cooley, WL. Guide for the construction of driven-rod ground belts. U.S. Bureau of Mines; 1978. Information Circular 8767
17. Bataller V, Muñoz A, Molina P, Mediano A, Cuchí JA, Villarroel JL. Improving medium access in through-the-earth VLF-LF communications. J Commun. 2009; 4(4):284–294.
18. Grece L, Popov M. On high-frequency circuit equivalents of a vertical ground rod. IEEE Trans Power Del. Apr; 2005 20(2):1598–1603.
19. Locke, D., editor. Electrical Contractors' Association. Guide to the IET Wiring Regulations: 17th Edition IET Wiring Regulations (BS 7671:2008). Hoboken, NJ, USA: Wiley; 2008. Appendix 12 —Earth Electrodes and Earth Electrode Testing
20. Bianchi C, Meloni A. Natural and man-made terrestrial electromagnetic noise: An outlook. Ann Geophys. Jun; 2007 50(3):435–440.
21. Damiano N, Yan L, Whisner B, Zhou C. Simulation and measurement of through-the-earth (TTE), extremely low-frequency signals using copper-clad, steel ground rods. Proc 2016 IEEE Ind Appl Soc Annu Meeting, Portland, OR USA. Oct.2016 :1–8. DOI: 10.1109/IAS.2016.7731930

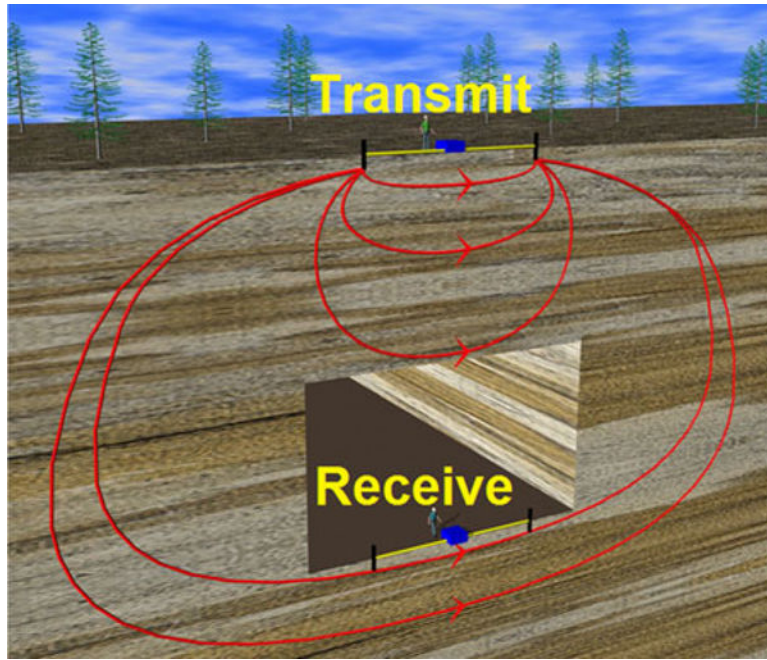

Fig. 1.
Drawing of an ELF transmission between surface and underground.

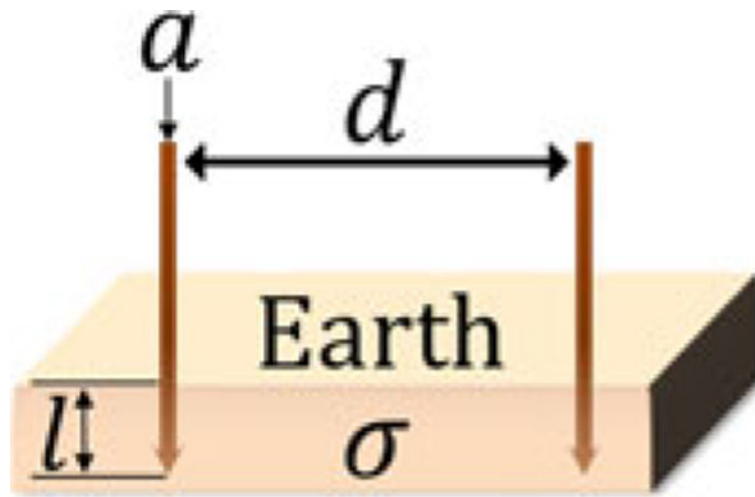

Fig. 2.
Drawing of an analytical model of two electrodes in earth medium.

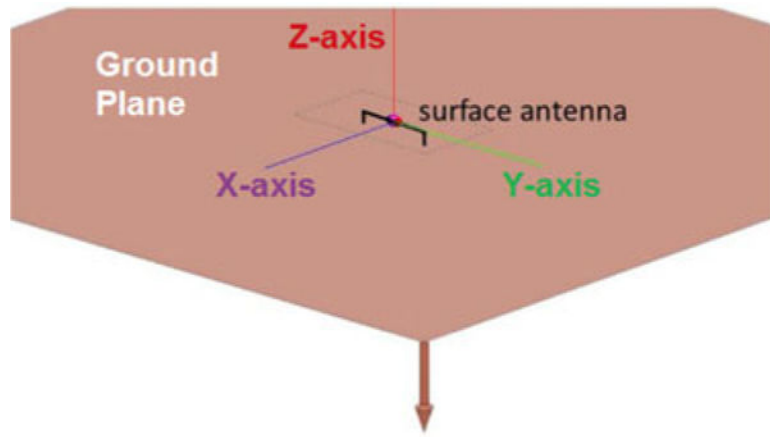

Fig. 3.
FEKO simulation using single-rod electrodes.

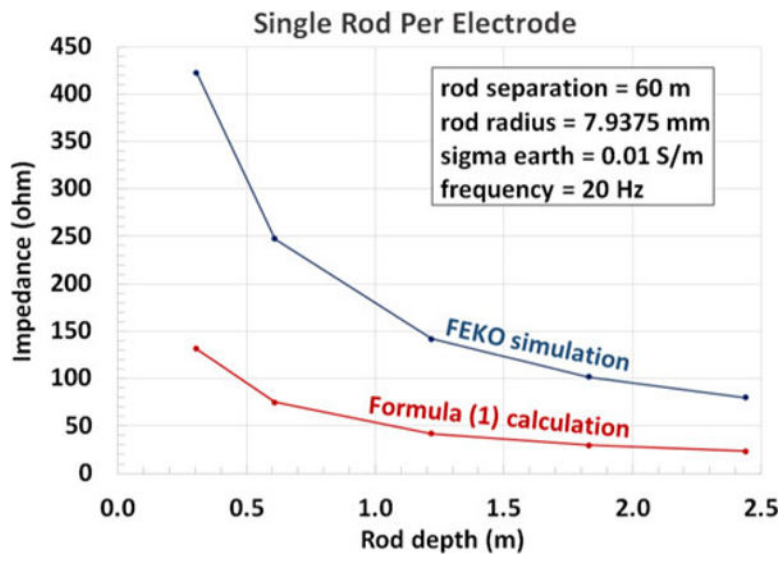

Fig. 4. Simulation and analytical results of a single-rod electrode in earth.

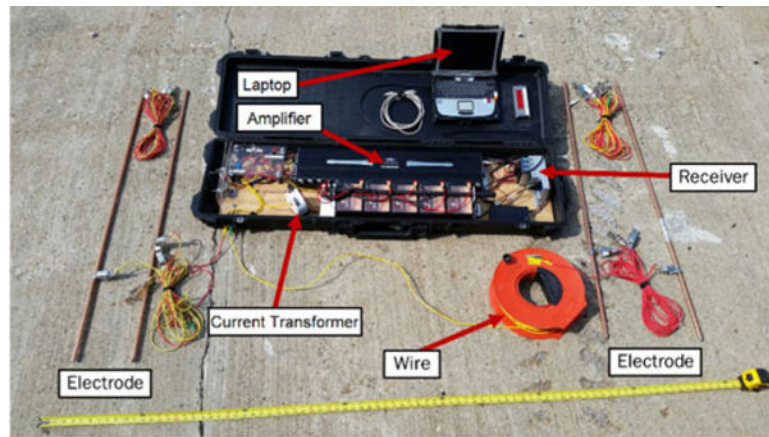

Fig. 5.
Electrode-based TTE measurement system.

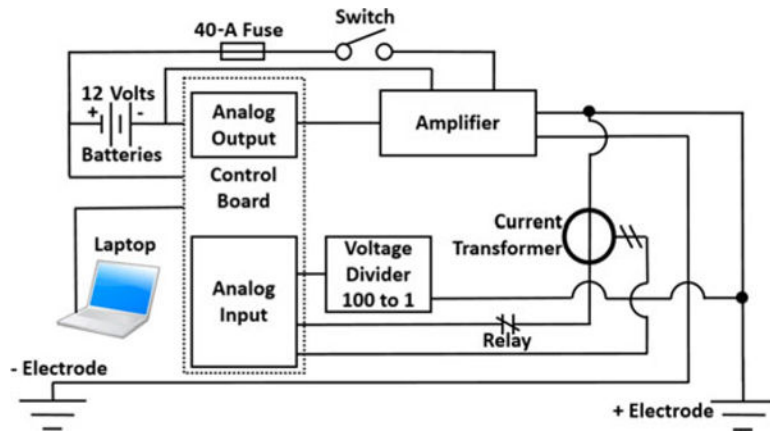

Fig. 6. Block diagram of the TTE measurement system.



Fig. 7.
Installing rods in a single earth electrode location.

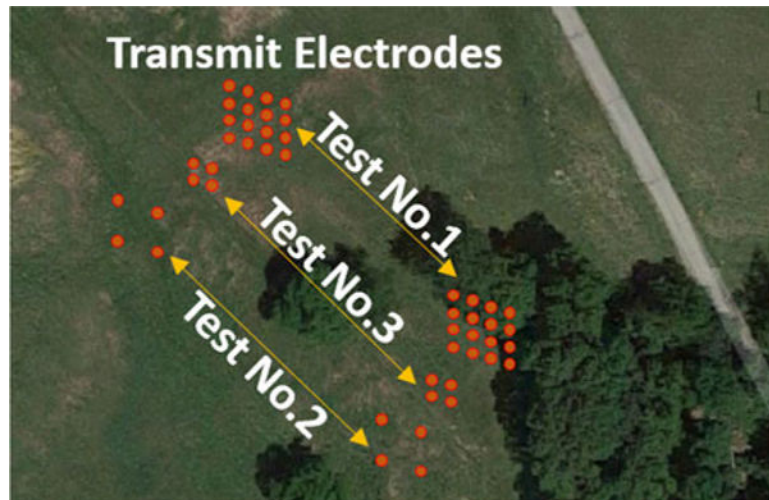

Fig. 8. Satellite image of the transmit area. The orange dots indicate a single ground rod's location. A cluster of dots represents one electrode.



Fig. 9. Satellite image of the receive area. The orange dots indicate a single ground rod's location. A cluster of dots represents one electrode.



Fig. 10.
Testing at one end of an earth electrode.

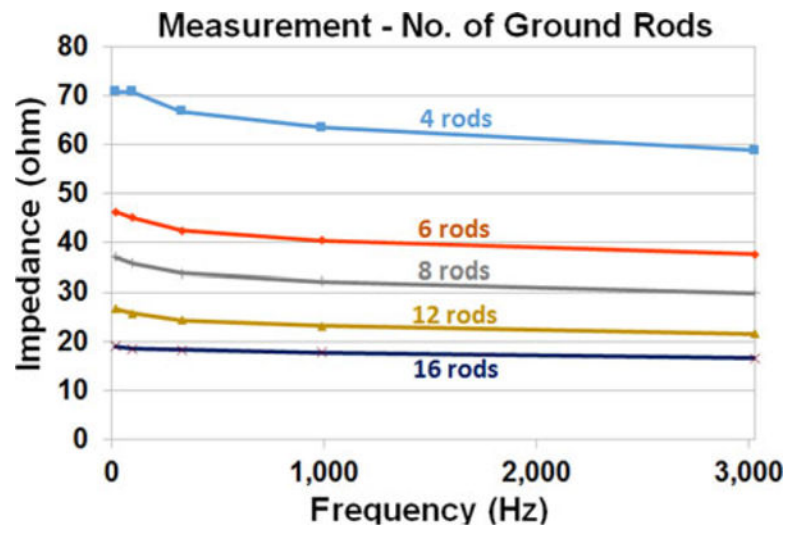

Fig. 11.
Field measurements varying the number of rods per electrode.

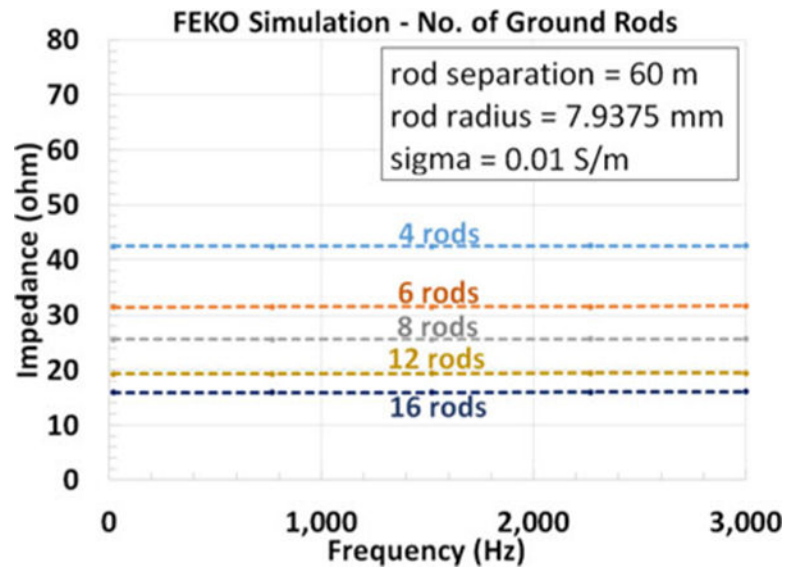

Fig. 12. FEKO simulation varying the number of rods per electrode.

Author Manuscript

Author Manuscript

Author Manuscript

Author Manuscript

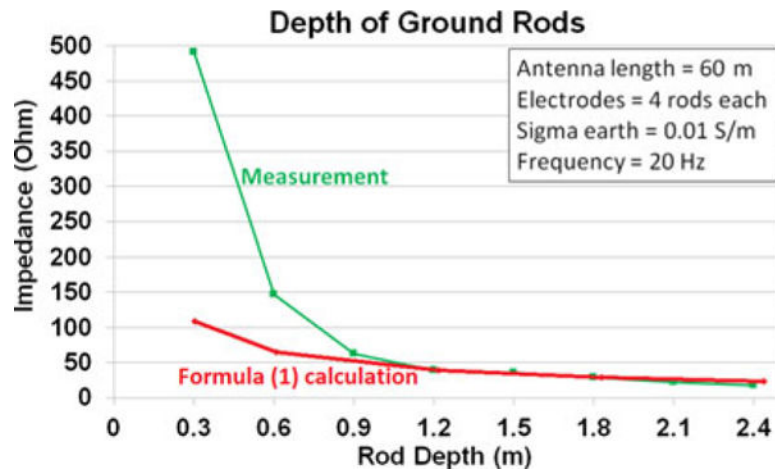

Fig. 13. Simulation-measurement of impedance based on rod depth, 20 Hz.

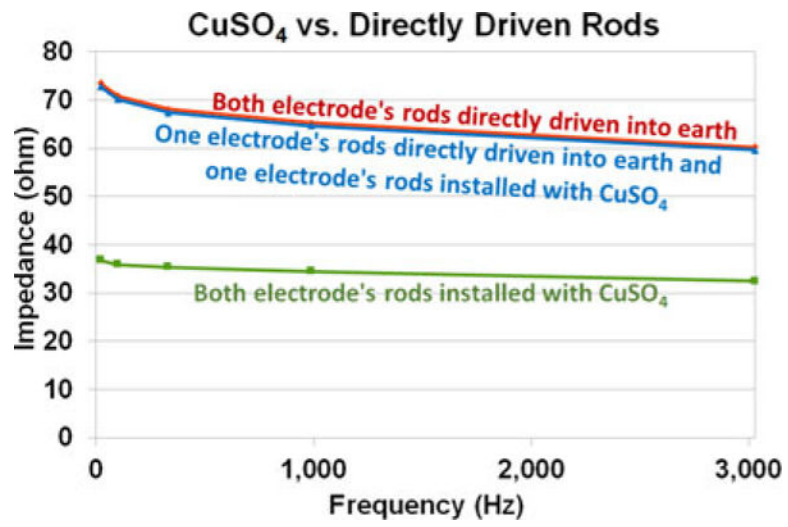

Fig. 14. Measurement of impedance based on rod installation.

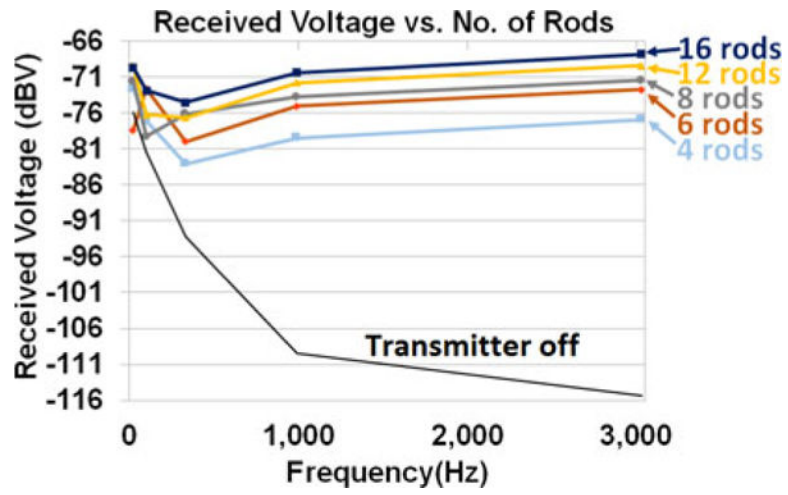

Fig. 15. Results for received signal varying the number of rods (test no. 1).