

**DRAFT
TOXICOLOGICAL PROFILE FOR
IODINE**

**U.S. DEPARTMENT OF HEALTH AND HUMAN SERVICES
Public Health Service
Agency for Toxic Substances and Disease Registry**

September 2001

DISCLAIMER

The use of company or product name(s) is for identification only and does not imply endorsement by the Agency for Toxic Substances and Disease Registry.

UPDATE STATEMENT

Toxicological profiles are revised and republished as necessary, but no less than once every three years. For information regarding the update status of previously released profiles, contact ATSDR at:

Agency for Toxic Substances and Disease Registry
Division of Toxicology/Toxicology Information Branch
1600 Clifton Road NE, E-29
Atlanta, Georgia 30333

FOREWORD

This toxicological profile is prepared in accordance with guidelines developed by the Agency for Toxic Substances and Disease Registry (ATSDR) and the Environmental Protection Agency (EPA). The original guidelines were published in the *Federal Register* on April 17, 1987. Each profile will be revised and republished as necessary.

The ATSDR toxicological profile succinctly characterizes the toxicologic and adverse health effects information for the hazardous substance described therein. Each peer-reviewed profile identifies and reviews the key literature that describes a hazardous substance's toxicologic properties. Other pertinent literature is also presented, but is described in less detail than the key studies. The profile is not intended to be an exhaustive document; however, more comprehensive sources of specialty information are referenced.

The focus of the profiles is on health and toxicologic information; therefore, each toxicological profile begins with a public health statement that describes, in nontechnical language, a substance's relevant toxicological properties. Following the public health statement is information concerning levels of significant human exposure and, where known, significant health effects. The adequacy of information to determine a substance's health effects is described in a health effects summary. Data needs that are of significance to protection of public health are identified by ATSDR and EPA.

Each profile includes the following:

- (A) The examination, summary, and interpretation of available toxicologic information and epidemiologic evaluations on a hazardous substance to ascertain the levels of significant human exposure for the substance and the associated acute, subacute, and chronic health effects;
- (B) A determination of whether adequate information on the health effects of each substance is available or in the process of development to determine levels of exposure that present a significant risk to human health of acute, subacute, and chronic health effects; and
- (C) Where appropriate, identification of toxicologic testing needed to identify the types or levels of exposure that may present significant risk of adverse health effects in humans.

The principal audiences for the toxicological profiles are health professionals at the Federal, State, and local levels; interested private sector organizations and groups; and members of the public. We plan to revise these documents in response to public comments and as additional data become available. Therefore, we encourage comments that will make the toxicological profile series of the greatest use.

Comments should be sent to:

Agency for Toxic Substances and Disease Registry
Division of Toxicology
1600 Clifton Road, N.E.
Mail Stop E-29
Atlanta, Georgia 30333

Background Information

The toxicological profiles are developed by ATSDR pursuant to Section 104(i) (3) and (5) of the Comprehensive Environmental Response, Compensation, and Liability Act of 1980 (CERCLA or Superfund) for hazardous substances found at Department of Energy (DOE) waste sites. CERCLA directs ATSDR to prepare toxicological profiles for hazardous substances most commonly found at facilities on the CERCLA National Priorities List (NPL) and that pose the most significant potential threat to human health, as determined by ATSDR and the EPA. ATSDR and DOE entered into a Memorandum of Understanding on November 4, 1992 which provided that ATSDR would prepare toxicological profiles for hazardous substances based upon ATSDR's or DOE's identification of need. The current ATSDR priority list of hazardous substances at DOE NPL sites was announced in the Federal Register on July 24, 1996 (61 FR 38451).

This profile reflects ATSDR's assessment of all relevant toxicologic testing and information that has been peer-reviewed. Staff of the Centers for Disease Control and Prevention and other Federal scientists have also reviewed the profile. In addition, this profile has been peer-reviewed by a nongovernmental panel and is being made available for public review. Final responsibility for the contents and views expressed in this toxicological profile resides with ATSDR.

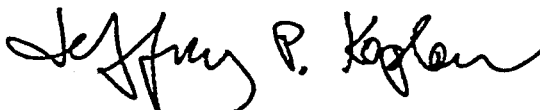

Jeffrey P. Koplan, M.D., M.P.H.
Administrator
Agency for Toxic Substances and
Disease Registry

QUICK REFERENCE FOR HEALTH CARE PROVIDERS

Toxicological Profiles are a unique compilation of toxicological information on a given hazardous substance. Each profile reflects a comprehensive and extensive evaluation, summary, and interpretation of available toxicologic and epidemiologic information on a substance. Health care providers treating patients potentially exposed to hazardous substances will find the following information helpful for fast answers to often-asked questions.

Primary Chapters/Sections of Interest

Chapter 1: Public Health Statement: The Public Health Statement can be a useful tool for educating patients about possible exposure to a hazardous substance. It explains a substance's relevant toxicologic properties in a nontechnical, question-and-answer format, and it includes a review of the general health effects observed following exposure.

Chapter 2: Relevance to Public Health: The Relevance to Public Health Section evaluates, interprets, and assesses the significance of toxicity data to human health.

Chapter 3: Health Effects: Specific health effects of a given hazardous compound are reported by *type of health effect* (death, systemic, immunologic, reproductive), by *route of exposure*, and by *length of exposure* (acute, intermediate, and chronic). In addition, both human and animal studies are reported in this section.

NOTE: Not all health effects reported in this section are necessarily observed in the clinical setting. Please refer to the Public Health Statement to identify general health effects observed following exposure.

Pediatrics: Four new sections have been added to each Toxicological Profile to address child health issues:

Section 1.7	How Can (Chemical X) Affect Children?
Section 1.8	How Can Families Reduce the Risk of Exposure to (Chemical X)?
Section 3.7	Children's Susceptibility
Section 6.6	Exposures of Children

Other Sections of Interest:

Section 3.8	Biomarkers of Exposure and Effect
Section 3.11	Methods for Reducing Toxic Effects

ATSDR Information Center

Phone: 1-888-42-ATSDR or (404) 498-0110 **Fax:** (404) 498-0057
E-mail: atsdric@cdc.gov **Internet:** <http://www.atsdr.cdc.gov>

The following additional material can be ordered through the ATSDR Information Center:

Case Studies in Environmental Medicine: Taking an Exposure History—The importance of taking an exposure history and how to conduct one are described, and an example of a thorough exposure history is provided. Other case studies of interest include *Reproductive and Developmental Hazards; Skin Lesions and Environmental Exposures; Cholinesterase-Inhibiting Pesticide Toxicity*; and numerous chemical-specific case studies.

Managing Hazardous Materials Incidents is a three-volume set of recommendations for on-scene (prehospital) and hospital medical management of patients exposed during a hazardous materials incident. Volumes I and II are planning guides to assist first responders and hospital emergency department personnel in planning for incidents that involve hazardous materials. Volume III—*Medical Management Guidelines for Acute Chemical Exposures*—is a guide for health care professionals treating patients exposed to hazardous materials.

Fact Sheets (ToxFAQs) provide answers to frequently asked questions about toxic substances.

Other Agencies and Organizations

The National Center for Environmental Health (NCEH) focuses on preventing or controlling disease, injury, and disability related to the interactions between people and their environment outside the workplace. *Contact:* NCEH, Mailstop F-29, 4770 Buford Highway, NE, Atlanta, GA 30341-3724 • Phone: 770-488-7000 • FAX: 770-488-7015.

The National Institute for Occupational Safety and Health (NIOSH) conducts research on occupational diseases and injuries, responds to requests for assistance by investigating problems of health and safety in the workplace, recommends standards to the Occupational Safety and Health Administration (OSHA) and the Mine Safety and Health Administration (MSHA), and trains professionals in occupational safety and health. *Contact:* NIOSH, 200 Independence Avenue, SW, Washington, DC 20201 • Phone: 800-356-4674 or NIOSH Technical Information Branch, Robert A. Taft Laboratory, Mailstop C-19, 4676 Columbia Parkway, Cincinnati, OH 45226-1998 • Phone: 800-35-NIOSH.

The National Institute of Environmental Health Sciences (NIEHS) is the principal federal agency for biomedical research on the effects of chemical, physical, and biologic environmental agents on human health and well-being. *Contact:* NIEHS, PO Box 12233, 104 T.W. Alexander Drive, Research Triangle Park, NC 27709 • Phone: 919-541-3212.

Referrals

The Association of Occupational and Environmental Clinics (AOEC) has developed a network of clinics in the United States to provide expertise in occupational and environmental issues. *Contact:* AOEC, 1010 Vermont Avenue, NW, #513, Washington, DC 20005 • Phone: 202-347-4976 • FAX: 202-347-4950 • e-mail: AOEC@AOEC.ORG • Web Page: <http://www.aoec.org/>.

The American College of Occupational and Environmental Medicine (ACOEM) is an association of physicians and other health care providers specializing in the field of occupational and environmental medicine. *Contact:* ACOEM, 55 West Seegers Road, Arlington Heights, IL 60005 • Phone: 847-818-1800 • FAX: 847-818-9266.

CONTRIBUTORS

CHEMICAL MANAGER(S)/AUTHORS(S):

John Risher, Ph.D.
ATSDR, Division of Toxicology, Atlanta, GA

Gary Diamond, Ph.D.
Richard Amata, Ph.D.
Stephen G. Swarts, Ph.D.
Syracuse Research Corporation, North Syracuse, NY

THE PROFILE HAS UNDERGONE THE FOLLOWING ATSDR INTERNAL REVIEWS:

1. Health Effects Review. The Health Effects Review Committee examines the health effects chapter of each profile for consistency and accuracy in interpreting health effects and classifying end points.
2. Minimal Risk Level Review. The Minimal Risk Level Workgroup considers issues relevant to substance-specific minimal risk levels (MRLs), reviews the health effects database of each profile, and makes recommendations for derivation of MRLs.
3. Data Needs Review. The Research Implementation Branch reviews data needs sections to assure consistency across profiles and adherence to instructions in the Guidance.

PEER REVIEW

A peer review panel was assembled for iodine. The panel consisted of the following members:

1. Dr. Raymond Lloyd, Professor Emeritus of Radiobiology, University of Utah, 729 Arapeen Dr., Salt Lake City, UT 84108-1218;
2. Dr. Kiyohiko Mabichi, National Cancer Institute, 6120 Executive Boulevard, Rockville, MD 20852;
3. Dr. Marvin Rallison, Professor Emeritus of Pediatric Endocrinology and Metabolism, University of Utah School of Medicine, 1706 Oakridge Dr., Salt Lake City, UT 84106;
4. Dr. Noel R. Rose, Professor of Molecular Medicine, Johns Hopkins University, 615 North Wolfe St., Baltimore, MD 21205;
5. Dr. Roy E. Shore, Professor and Director, Division of Epidemiology and Biostatistics, New York University School of Medicine, 650 First Ave., New York, NY 10016-3240

These experts collectively have knowledge of iodine's physical and chemical properties, toxicokinetics, key health end points, mechanisms of action, human and animal exposure, and quantification of risk to humans. All reviewers were selected in conformity with the conditions for peer review specified in Section 104(I)(13) of the Comprehensive Environmental Response, Compensation, and Liability Act, as amended.

Scientists from the Agency for Toxic Substances and Disease Registry (ATSDR) have reviewed the peer reviewers' comments and determined which comments will be included in the profile. A listing of the peer reviewers' comments not incorporated in the profile, with a brief explanation of the rationale for their exclusion, exists as part of the administrative record for this compound. A list of databases reviewed and a list of unpublished documents cited are also included in the administrative record.

The citation of the peer review panel should not be understood to imply its approval of the profile's final content. The responsibility for the content of this profile lies with the ATSDR.

CONTENTS

FOREWORD	v
QUICK REFERENCE FOR HEALTH CARE PROVIDERS	vii
CONTRIBUTORS	ix
PEER REVIEW	xi
LIST OF FIGURES	xvii
LIST OF TABLES	xix
1. PUBLIC HEALTH STATEMENT	1
1.1 WHAT IS IODINE?	1
1.2 WHAT HAPPENS TO IODINE WHEN IT ENTERS THE ENVIRONMENT?	2
1.3 HOW MIGHT I BE EXPOSED TO IODINE?	2
1.4 HOW CAN IODINE ENTER AND LEAVE MY BODY?	3
1.5 HOW CAN IODINE AFFECT MY HEALTH?	4
1.6 HOW CAN IODINE AFFECT CHILDREN?	4
1.7 HOW CAN FAMILIES REDUCE THE RISK OF EXPOSURE TO IODINE?	5
1.8 IS THERE A MEDICAL TEST TO DETERMINE WHETHER I HAVE BEEN EXPOSED TO IODINE?	6
1.9 WHAT RECOMMENDATIONS HAS THE FEDERAL GOVERNMENT MADE TO PROTECT HUMAN HEALTH?	6
1.10 WHERE CAN I GET MORE INFORMATION?	7
2. RELEVANCE TO PUBLIC HEALTH	9
2.1 BACKGROUND AND ENVIRONMENTAL EXPOSURES TO IODINE IN THE UNITED STATES	9
2.2 SUMMARY OF HEALTH EFFECTS	10
2.3 MINIMAL RISK LEVELS	23
3. HEALTH EFFECTS	27
3.1 INTRODUCTION	27
3.2 DISCUSSION OF HEALTH EFFECTS BY ROUTE OF EXPOSURE	27
3.2.1 Inhalation Exposure	28
3.2.1.1 Death	29
3.2.1.2 Systemic Effects	30
3.2.1.3 Immunological and Lymphoreticular Effects	30
3.2.1.4 Neurological Effects	30
3.2.1.5 Reproductive Effects	31
3.2.1.6 Developmental Effects	31
3.2.1.7 Cancer	31
3.2.2 Oral Exposure	31
3.2.2.1 Death	36
3.2.2.2 Systemic Effects	37
3.2.2.3 Immunological and Lymphoreticular Effects	68
3.2.2.4 Neurological Effects	73
3.2.2.5 Reproductive Effects	74
3.2.2.6 Developmental Effects	76
3.2.2.7 Cancer	77

3.2.3	Dermal Exposure	97
3.2.3.1	Death	97
3.2.3.2	Systemic Effects	98
3.2.3.3	Immunological and Lymphoreticular Effects	100
3.2.3.4	Neurological Effects	101
3.2.3.5	Reproductive Effects	101
3.2.3.6	Developmental Effects	101
3.2.3.7	Cancer	102
3.2.4	External Exposure	102
3.2.4.1	Death	102
3.2.4.2	Systemic Effects	102
3.2.4.3	Immunological and Lymphoreticular Effects	102
3.2.4.4	Neurological Effects	102
3.2.4.5	Reproductive Effects	102
3.2.4.6	Developmental Effects	102
3.2.4.7	Cancer	102
3.2.5	Other Routes of Exposure	102
3.3	GENOTOXICITY	102
3.4	TOXICOKINETICS	104
3.4.1	Absorption	104
3.4.1.1	Inhalation Exposure	104
3.4.1.2	Oral Exposure	104
3.4.1.3	Dermal Exposure	107
3.4.1.4	Other Routes of Exposure	110
3.4.2	Distribution	110
3.4.2.1	Inhalation Exposure	110
3.4.2.2	Oral Exposure	110
3.4.2.3	Dermal Exposure	114
3.4.2.4	Other Routes of Exposure	114
3.4.3	Metabolism	114
3.4.3.1	Inhalation Exposure	114
3.4.3.2	Oral Exposure	115
3.4.3.3	Dermal Exposure	121
3.4.4	Elimination and Excretion	121
3.4.4.1	Inhalation Exposure	121
3.4.4.2	Oral Exposure	121
3.4.4.3	Dermal Exposure	123
3.4.4.4	Other Routes of Exposure	123
3.4.5	Physiologically Based Pharmacokinetic (PBPK)/Pharmacodynamic (PD) Models	123
3.5	MECHANISMS OF ACTION	142
3.5.1	Pharmacokinetic Mechanisms	142
3.5.2	Mechanisms of Toxicity	148
3.5.3	Animal-to-Human Extrapolations	149
3.6	ENDOCRINE DISRUPTION	150
3.7	CHILDREN'S SUSCEPTIBILITY	151
3.8	BIOMARKERS OF EXPOSURE AND EFFECT	155
3.8.1	Biomarkers Used to Identify or Quantify Exposure to Iodine	156
3.8.2	Biomarkers Used to Characterize Effects Caused by Iodine	157
3.9	INTERACTIONS WITH OTHER CHEMICALS	159
3.10	POPULATIONS THAT ARE UNUSUALLY SUSCEPTIBLE	162
3.11	METHODS FOR REDUCING TOXIC EFFECTS	164
3.11.1	Reducing Peak Absorption Following Exposure	164
3.11.2	Reducing Body Burden	164
3.11.3	Interfering with the Mechanism of Action for Toxic Effects	165

3.12	ADEQUACY OF THE DATABASE	165
3.12.1	Existing Information on Health Effects of Iodine	166
3.12.2	Identification of Data Needs	166
3.12.3	Ongoing Studies	171
4.	CHEMICAL, PHYSICAL, AND RADIOLOGICAL INFORMATION	173
4.1	CHEMICAL IDENTITY	173
4.2	PHYSICAL, CHEMICAL, AND RADIOLOGICAL PROPERTIES	173
5.	PRODUCTION, IMPORT/EXPORT, USE, AND DISPOSAL	181
5.1	PRODUCTION	181
5.2	IMPORT/EXPORT	182
5.3	USE	182
5.4	DISPOSAL	182
6.	POTENTIAL FOR HUMAN EXPOSURE	185
6.1	OVERVIEW	185
6.2	RELEASES TO THE ENVIRONMENT	191
6.2.1	Air	192
6.2.2	Water	196
6.2.3	Soil	197
6.3	ENVIRONMENTAL FATE	199
6.3.1	Transport and Partitioning	199
6.3.2	Transformation and Degradation	203
6.3.2.1	Air	203
6.3.2.2	Water	205
6.3.2.3	Sediment and Soil	206
6.3.2.4	Other Media	206
6.4	LEVELS MONITORED OR ESTIMATED IN THE ENVIRONMENT	206
6.4.1	Air	206
6.4.2	Water	207
6.4.3	Sediment and Soil	212
6.4.4	Other Environmental Media	212
6.5	GENERAL POPULATION AND OCCUPATIONAL EXPOSURE	216
6.6	EXPOSURES OF CHILDREN	222
6.7	POPULATIONS WITH POTENTIALLY HIGH EXPOSURES	224
6.8	ADEQUACY OF THE DATABASE	226
6.8.1	Identification of Data Needs	227
6.8.2	Ongoing Studies	229
7.	ANALYTICAL METHODS	231
7.1	BIOLOGICAL MATERIALS	231
7.1.1	Internal Iodine Measurements	231
7.1.2	External Measurements	237
7.2	ENVIRONMENTAL SAMPLES	240
7.2.1	Field Measurements of Iodine	240
7.2.2	Laboratory Analysis of Environmental Samples	240
7.3	ADEQUACY OF THE DATABASE	252
7.3.1	Identification of Data Needs	253
7.3.2	Ongoing Studies	253
8.	REGULATIONS AND ADVISORIES	255
9.	REFERENCES	273

10. GLOSSARY 415

APPENDICES

A. ATSDR MINIMAL RISK LEVELS AND WORKSHEETS A-1

B. USER'S GUIDE B-1

C. ACRONYMS, ABBREVIATIONS, AND SYMBOLS C-1

D. OVERVIEW OF BASIC RADIATION PHYSICS, CHEMISTRY AND BIOLOGY D-1

LIST OF FIGURES

3-1. Levels of Significant Exposure to Iodine—Chemical Toxicity—Oral	45
3-2. Levels of Significant Exposure to Iodine—Radiation Toxicity—Oral	80
3-3. Pathways Uptake and Metabolism of Iodide in the Thyroid Gland	116
3-4. Thyroid Hormones and Metabolic Precursors	117
3-5. Pathways of Metabolism of Iodothyronines	119
3-6. Major Deiodination Pathways of Thyroid Hormones in Peripheral Tissues	120
3-7. Conceptual Representation of a Physiologically Based Pharmacokinetic (PBPK) Model for a Hypothetical Chemical Substance	125
3-8. Respiratory Tract Compartments in Which Particles May be Deposited	127
3-9. Reaction of Gases or Vapors at Various Levels of the Gas-Blood Interface	129
3-10. Compartment Model to Represent Time-Dependent Particle Transport in the Respiratory Tract	133
3-11. The Human Respiratory Tract Model: Absorption into Blood	135
3-12. ICRP (1989) Metabolic Model for Iodine	137
3-13. NRPB-UK (1989) Metabolic Model for Iodine	139
3-14. Existing Information on Health Effects of Stable Iodine	167
3-15. Existing Information on Health Effects of Radioactive Iodine	168
6-1. Frequency of NPL Sites with Iodine Contamination	186
6-2. Frequency of NPL Sites with Iodine 129 Contamination	187
6-3. Frequency of NPL Sites with Iodine 131 Contamination	188
6-4. Geochemical Cycle of Triad Elements (I, Br, Cl)	193
6-5. An Outline of the Movement of Iodine in the Environment	194
6-6. Diagram of the Global Iodine Cycle at Steady State Showing Environmental Compartments, Compartment Inventories in Grams (g), Transport Pathways, and Fluxes in Grams per Year (g/year)	200
6-7. A Simplified Scheme of Iodine Cycling in the Marine Boundary Layer	204

LIST OF TABLES

2-1. Thyroid Doses and Dose Rates for Various Isotopes of Iodine ^a	13
2-2. Releases from Radioiodine-producing Events	17
3-1. Levels of Significant Exposure to Iodine—Chemical Toxicity—Oral	38
3-2. Levels of Significant Exposure to Iodine—Radiation Toxicity—Oral	78
3-3. Estimated Thyroid Radiation Doses in Populations Studied for Radioiodine-related Cancers	85
3-4. Binding Characteristics of Major Human Thyroid Hormone-Binding Proteins	112
3-5. Reference Respiratory Values for a General Caucasian Population at Different Levels of Activity	128
3-6. Reference Values of Parameters for the Compartment Model to Represent Time-dependent Particle Transport from the Human Respiratory Tract	131
3-7. Properties of Human Iodothyronine Selenodeiodinases	147
3-8. Typical Reference Ranges for Serum Thyroid Hormones and TSH in Humans	158
3-9. Ongoing Studies on Health Effects of Radioactive Iodine	172
4-1. Chemical Identity of Iodine and Iodine Compounds	174
4-2. Physical and Chemical Properties of Iodine and Iodine Compounds	176
4-3. Percent Natural Occurrence and Radioactive Properties of Isotopes of Iodine	179
6-1. Approximate Releases of ¹²⁹ I from Atmospheric and High Altitude Nuclear Weapons Tests ...	208
6-2. Concentration of Iodine, Chloride, and ¹²⁹ I/ ¹²⁷ I Ratio in Air and Precipitation as a Function of Location and Collection Time	210
6-3. Iodine Content in Specific Soil Types	213
6-4. Iodine Content in Missouri Soils as a Function of Depth and Parent Material	214
6-5. Estimated Average Iodine Intake for Adults in the United States	218
7-1. Analytical Methods for Determining Iodine in Biological Samples	232
7-2. Analytical Methods for Determining Radioiodine in Biological Samples	238
7-3. Analytical Methods for Determining Iodine in Environmental Samples	241
7-4. Analytical Methods for Determining Radioiodine in Environmental Samples	246
8-1. Regulations and Guidelines Applicable to Stable Iodine	256
8-2. Regulations and Guidelines Applicable to Radioactive Iodine	260
8-3. Dose Coefficients ^a (e(50)) for Intakes of Iodine Radionuclides	272

1. PUBLIC HEALTH STATEMENT

This public health statement tells you about iodine and the effects of exposure.

The Environmental Protection Agency (EPA) identifies the most serious hazardous waste sites in the nation. These sites make up the National Priorities List (NPL) and are the sites targeted for long-term federal cleanup activities. Iodine has been found in at least 8 sites. Radioactive iodine has been found at 8 sites, including iodine 129 (^{129}I) in at least 2 sites, and iodine 131 (^{131}I) in at least 6 sites of the 1,585 current or former NPL sites. However, the total number of NPL sites evaluated for iodine is not known. As more sites are evaluated, the sites at which iodine is found may increase. This information is important because exposure to iodine may harm you and because these sites may be sources of exposure.

When a substance is released from a large area, such as an industrial plant, or from a container, such as a drum or bottle, it enters the environment. This release does not always lead to exposure. You are exposed to a substance only when you come in contact with it. You may be exposed by breathing, eating, or drinking the substance, or by skin contact. You can be exposed to some forms of radiation by being near a radioactive substance.

If you are exposed to either radioactive or stable iodine, many factors determine whether you'll be harmed. These factors include the dose (how much), the duration (how long), and how you come in contact with it. You must also consider the other chemicals you're exposed to and your age, sex, diet, family traits, lifestyle, and state of health.

1.1 WHAT IS IODINE?

Iodine is a naturally occurring element that is essential for the good health of people and animals. Iodine is found in small amounts in sea water and in certain rocks and sediments. Iodine occurs in many different forms that can be blue, brown, yellow, red, white, or colorless. Most forms of iodine easily dissolve in water or alcohol. Iodine has many uses. Its most important use is as a disinfectant for cleaning surfaces and storage containers. Iodine is also used in skin soaps and bandages, and for purifying water. Iodine is used in medicines. Iodine is added to food, such as table salt, to ensure that all people in the United States have enough iodine in their bodies to form essential thyroid hormones. Iodine is put into animal feeds for the

1. PUBLIC HEALTH STATEMENT

same reason. Iodine is used in the chemical industry for making inks and coloring agents, chemicals used in photography, and in making batteries, fuels, and lubricants. Radioactive iodine also occurs naturally. Radioactive iodine is used in medical tests and to treat certain diseases, such as over activity or cancer of the thyroid gland.

1.2 WHAT HAPPENS TO IODINE WHEN IT ENTERS THE ENVIRONMENT?

The oceans are the most important source of natural iodine in the air, water, and soil. Iodine in the oceans enters the air from sea spray or as iodine gases. Once in the air, iodine can combine with water or with particles in the air and can enter the soil and surface water, or land on vegetation when these particles fall to the ground or when it rains. Iodine can remain in soil for a long time because it combines with organic material in the soil. It can also be taken up by plants that grow in the soil. Cows or other animals that eat these plants will take up the iodine in the plants. Iodine that enters surface water can reenter the air as iodine gases. Iodine can enter the air when coal or fuel oil is burned for energy; however, the amount of iodine that enters the air from these activities is very small compared to the amount that comes from the oceans.

Radioactive iodine also forms naturally from chemical reactions high in the atmosphere. Most radioactive forms of iodine change very quickly (seconds to days) to stable elements that are not radioactive. However, one form, ^{129}I , changes very slowly (millions of years), and its levels build up in the environment. Small amounts of radioactive iodine, including ^{129}I and ^{131}I , can also enter the air from nuclear power plants, which form radioiodine from uranium and plutonium. Larger amounts of radioactive iodine have been released to the air from accidents at nuclear power plants and from explosions of nuclear bombs.

1.3 HOW MIGHT I BE EXPOSED TO IODINE?

Iodine is a natural and necessary part of the food that you eat and the water that you drink. In the United States, most table salt contains iodine. Iodine is put into table salt to make sure that everyone has enough iodine in their bodies to form essential thyroid hormones. In the past, people in some areas of the United States did not get enough iodine in their diets. Iodine is in some breads because it is added to flour to condition bread dough for baking. Iodine is also in cow and goat milk. Iodine gets into milk when cows or goats eat iodine that is in their food and water. Iodine can also get into milk when iodine is used to clean milking machines and milk

1. PUBLIC HEALTH STATEMENT

storage containers, and to clean the animals' udders at dairy farms and dairies. Iodine is in ocean fish, shellfish, and certain plants that grow in the ocean (kelp). This is because there is iodine in sea water and some sea plants and animals concentrate iodine in their tissues. Iodine can also be in the air. Iodine is in sea spray and mist, which are tiny drops of seawater. Iodine is in cleansers and medicines that are used to clean and bandage skin wounds (tincture of iodine). You can be exposed to these if they are placed on your skin. Some medicines have iodine in them. Iodine is used to treat water to make it safe for drinking. You can buy iodine water purifying tablets that you add directly to water. You can also buy water treatment cartridges for your home that have iodine in them. Some iodine will get into the water that you drink if you use these tablets or cartridges.

People are almost never exposed to radioactive iodine, unless they work in a place where radioactive iodine is used or if they are given radioactive iodine by their doctors. Radioactive iodine is used in certain medical tests and treatments. You might have these tests if your doctor needs to look for problems in your thyroid gland or if your doctor needs to treat you for a problem with your thyroid gland. In the past, people were exposed to radioactive iodine released from nuclear bomb tests, after accidental explosions and fires at nuclear power plants, or from facilities that processed or used nuclear fuel for power plants.

1.4 HOW CAN IODINE ENTER AND LEAVE MY BODY?

Most of the iodine that enters your body comes from the food that you eat. A smaller amount comes from the water that you drink. Iodine will enter your body if it is in the air that you breathe. Some forms of iodine can enter your body when placed on the skin. Iodine can also be injected into your blood by your doctor for special medical tests or treatments. Iodine that enters your body quickly goes into your thyroid gland, a small important organ in your neck. Iodine is used in the thyroid gland to make hormones that are needed for growth and health. Almost all of the iodine in your body is in your thyroid gland. Iodine that does not go into your thyroid gland leaves the body in your urine, in a few weeks to months. Iodine that leaves your body each day is usually replaced by the iodine that you eat in your food, so that the amount of iodine in your body is just enough to keep you healthy. Small amounts of iodine can also leave your body in sweat or in breast milk.

1. PUBLIC HEALTH STATEMENT

1.5 HOW CAN IODINE AFFECT MY HEALTH?

Iodine is needed for your thyroid gland to produce thyroid hormones. You and your thyroid gland are healthy when there is just enough iodine in your body, about 10–15 milligrams so that just the right amount of thyroid hormones are produced. This amount would look like much less than a pinch of table salt if placed in your hand. This amount of iodine is in most people when they eat the foods that people normally eat in the United States. Your thyroid gland can become unhealthy if more or less than this amount of iodine is in your body. An unhealthy thyroid gland can affect your entire body. If the thyroid gland cannot make enough hormone, then you would have to be given thyroid hormone in pills. If your thyroid gland makes too much hormone, then you would have to be given drugs to make your thyroid make less hormone. Radioactive iodine can also be unhealthy for your thyroid gland. If too much radioactive iodine enters your body, the radioactive iodine will destroy your thyroid gland so that the gland will stop making hormones. Too much radioactive iodine in your body can also cause thyroid nodules or cancer.

To protect the public from the harmful effects of toxic chemicals and to find ways to treat people who have been harmed, scientists use many tests.

One way to see if a chemical will hurt people is to learn how the chemical is absorbed, used, and released by the body. In the case of a radioactive chemical, it is also important to gather information concerning the radiation dose and dose rate to the body. For some chemicals, animal testing may be necessary. Animal testing may also be used to identify health effects such as cancer or birth defects. Without laboratory animals, scientists would lose a basic method to get information needed to make wise decisions to protect public health. Scientists have the responsibility to treat research animals with care and compassion. Laws today protect the welfare of research animals, and scientists must comply with strict animal care guidelines.

1.6 HOW CAN IODINE AFFECT CHILDREN?

This section discusses potential health effects from exposures during the period from conception to maturity at 18 years of age in humans.

Babies and children need iodine to form thyroid hormones, which are important for growth and health. If infants and children do not have enough iodine in their bodies, their thyroid glands

1. PUBLIC HEALTH STATEMENT

will not produce enough thyroid hormone and they will not grow normally. If they have too much iodine in their bodies, they will develop enlarged thyroid gland (goiter), which also do not produce enough thyroid hormone for normal growth. We also need just the right amount of iodine from our mothers before we are born. Too much iodine from the mother can cause a baby's thyroid gland to be so large that it makes breathing difficult or impossible. Not enough iodine from the mother can cause a baby to not produce enough thyroid hormone, which can affect growth and mental development of the baby. Radioactive iodine in food can be more harmful to babies and children than to adults. When radioactive iodine is in the air, it can get onto the grass and water that the cows eat and drink. Infants and children drink a lot more milk than most adults. So, if there is radioactive iodine in the milk that a child or infant drinks, more iodine will enter the thyroid gland of the child than of an adult who drinks less milk. And, because the thyroid gland of a child or infant is smaller than that of an adult, the child's thyroid gland will receive a higher radiation dose than the adult. Children are more sensitive to the harmful toxic effects of iodine and radioactive iodine than adults because their thyroid glands are still growing and the thyroid gland tissues are more easily harmed by radioactive iodine, and because children need a healthy thyroid gland for normal growth.

1.7 HOW CAN FAMILIES REDUCE THE RISK OF EXPOSURE TO IODINE?

If your doctor finds that you have been exposed to significant amounts of iodine, ask whether your children might also be exposed. Your doctor might need to ask your state health department to investigate.

We all are exposed to iodine in the food that we eat and in the water that we drink. Iodine is needed for your good health. We do not want to prevent exposure to iodine, but we do want to try to prevent exposure to too much iodine. This is not likely to happen from eating a normal diet in the United States or from drinking water or breathing air. It could happen if you were careless about storing soaps or cleansers or medicines that have iodine in them. For example, a child could swallow medicines that contain iodine. People are almost never exposed to radioactive iodine, unless they work in a place where radioactive iodine is used or if they are given radioactive iodine by their doctors for certain medical tests or treatments.

1. PUBLIC HEALTH STATEMENT

1.8 IS THERE A MEDICAL TEST TO DETERMINE WHETHER I HAVE BEEN EXPOSED TO IODINE?

Most physicians do not test for iodine in their offices, but can collect samples and send them to special laboratories. They can also feel the thyroid for lumps that may have been caused by disease or past exposure to radioactive iodine, but the physical examination of the neck or tests for iodine do not always reveal the cause of the problem. Every person's body contains a small amount of iodine, but normally not radioactive iodine (such as ^{131}I). Iodine can be measured in the blood, urine, and saliva. The amount is normally measured by its mass (in grams). If the iodine is radioactive, it can be measured by its mass or by its radiation emissions. These emissions are used to tell the amount of radioactive iodine (in Becquerels or curies) and the radiation dose that it gives to your body (in Sieverts or rem). Radiation detectors can measure radioactive iodine inside your body using the radiation coming from the thyroid gland in your neck. This is useful only if you recently inhaled or ingested some, or if your physician recently gave you some for medical purposes. Your body quickly eliminates iodine and radioactive iodine, so tests should be done shortly after exposure.

1.9 WHAT RECOMMENDATIONS HAS THE FEDERAL GOVERNMENT MADE TO PROTECT HUMAN HEALTH?

The federal government develops regulations and recommendations to protect public health. Regulations can be enforced by law. Federal agencies that develop regulations for toxic substances include the Environmental Protection Agency (EPA), the Occupational Safety and Health Administration (OSHA), the Food and Drug Administration (FDA), and the Nuclear Regulatory Commission (NRC).

Recommendations provide valuable guidelines to protect public health but cannot be enforced by law. Federal organizations that develop recommendations for toxic substances include the Agency for Toxic Substances and Disease Registry (ATSDR), the National Institute for Occupational Safety and Health (NIOSH), and the FDA.

Regulations and recommendations can be expressed in not-to-exceed levels in air, water, soil, or food that are usually based on levels that affect animals; then they are adjusted to help protect people. Sometimes these not-to-exceed levels differ among federal organizations because of

1. PUBLIC HEALTH STATEMENT

different exposure times (an 8-hour workday or a 24-hour day), the use of different animal studies, or other factors.

Recommendations and regulations are also periodically updated as more information becomes available. For the most current information, check with the federal agency or organization that provides it. Some regulations and recommendations for iodine include the following:

The National Research Council has established a Recommended Dietary Allowance for iodine of 150 µg/day, with additional allowances of 25 µg/day during pregnancy and 50 µg/day during nursing. The EPA has established regulations that limit releases of certain forms of radioactive iodine to the environment and limits for requiring that industries report releases of certain forms of radioactive iodine. NIOSH has established recommendations for limits of worker exposures to iodine and radioactive iodine. The Nuclear Regulatory Commission, the National Council of Radiation Protection and Measurement (NRC), and the International Commission of Radiological Protection (ICRP) have established recommended limits for worker exposures to radioactive iodine and for releases of radioactive iodine to the environment.

1.10 WHERE CAN I GET MORE INFORMATION?

If you have any more questions or concerns, please contact your community or state health or environmental quality department, your regional Nuclear Regulatory Commission office, or

Agency for Toxic Substances and Disease Registry
Division of Toxicology
1600 Clifton Road NE, Mailstop E-29
Atlanta, GA 30333

* Information line and technical assistance

Phone: 1-888-42-ATSDR (1-888-422-8737)
Fax: 1-404-498-0057

ATSDR can also tell you the location of occupational and environmental health clinics. These clinics specialize in recognizing, evaluating, and treating illnesses resulting from exposure to hazardous substances.

1. PUBLIC HEALTH STATEMENT

* To order toxicological profiles, contact

National Technical Information Service
5285 Port Royal Road
Springfield, VA 22161
Phone: 1-800-553-6847 or 1-703-605-6000

2. RELEVANCE TO PUBLIC HEALTH

2.1 BACKGROUND AND ENVIRONMENTAL EXPOSURES TO IODINE IN THE UNITED STATES

Iodine is an essential nutrient. Adequate intakes of iodine are required for the production of thyroid hormones. The term *iodine excess* is used in this profile to refer to increases in intake relative to estimated physiological requirements. As a reference point, the chronic dietary intake of iodine in U.S. populations has been estimated to range from approximately 150 to 950 µg/day. Estimates for various populations have ranged from <50 µg/day in iodine-deficient regions to >10 mg/day in populations that regularly ingest seaweeds containing a high iodine content. The National Research Council Recommended Dietary Allowance (RDA) for iodine is 150 µg/day (2.1 µg/kg/day for a 70-kg adult), with additional allowances of 25 and 50 µg/day during pregnancy and lactation, respectively.

The diet is the major source of iodine intake in the U.S. population. Iodine enters the human diet from a variety of natural sources, including mineral dissolution and atmospheric transport and deposition of seawater aerosols to surface water, vegetation, and soil. Major food categories that contribute to dietary iodine include marine produce (e.g., fish and shellfish) and milk. Cows and goats absorb iodine from ingested vegetation and water, when iodine is either deposited on the vegetation or in water or when the iodine is taken up by vegetation grown in soils containing iodine. The absorbed iodine is excreted into their milk; goat milk typically has higher concentrations of iodine than cow milk for equal deposition on feed. Additional sources of iodine in milk derive from the use of iodine disinfectants on cows, milking machines, and other milk processing equipment, as well as from supplementation of dairy feed with iodine-containing compounds. Breast milk is the primary source of iodine intake in nursing infants. Commercial infant formula preparations are fortified with sufficient iodine to support infant health, growth, and development. Cow milk is a significant source of iodine intake in children. Iodine is also intentionally added to the U.S. diet as iodized table salt and as iodine-containing bread dough oxidizers. Other sources of intake derive from the use of iodine-containing topical disinfectants (e.g., povidone-iodine), iodine-containing diagnostic and therapeutic agents, dietary supplements, and water purifiers containing iodine.

Thirty-five isotopes of iodine are recognized (^{108}I through ^{142}I). Only one isotope is stable (^{127}I); the remaining are radioactive. Most of these have radioactive half-lives of minutes or less. Twelve have half-lives that exceed 1 hour, and five have half-lives that exceed 1 day (^{124}I , ^{125}I , ^{126}I , ^{129}I , and ^{131}I). Three isotopes (^{125}I , ^{129}I , and ^{131}I) are of particular interest with respect to human exposures because ^{125}I and ^{131}I are used medically and all three are sufficiently long-lived to be transported to human receptors after their release into the environment. The U.S. population has been exposed to radioiodine in the general

2. RELEVANCE TO PUBLIC HEALTH

environment as a result of atmospheric fallout of radioiodine released from uncontained and/or uncontrolled nuclear reactions. Historically, these have included surface or atmospheric detonation of nuclear bombs, routine and accidental releases from nuclear power plants and nuclear fuel reprocessing facilities, and from hospitals and medical research facilities. Estimates have been made of radiation doses to the U.S. population attributable to nuclear bomb tests conducted during the 1950s and 1960s at the Nevada Test Site; however, dose estimates for global fallout have not been completed. Geographic-specific geometric mean lifetime doses are estimated to have ranged from 0.19 to 43 cGy (rad) for people born on January 1, 1952 who consumed milk only from commercial retail sources, 0.7–55 cGy (rad) for people who consumed milk only from home-reared cows, and 6.4–330 cGy (rad) for people who consumed milk only from home-reared goats. Additional information is available on global doses from nuclear bomb tests, and doses from nuclear fuel processing, and medical uses can be found in UNSCEAR.

Individuals in the United States can also be exposed to radioiodine, primarily ^{123}I and ^{131}I , as a result of clinical procedures in which radioiodine compounds are administered to detect abnormalities of the thyroid gland or to destroy the thyroid gland to treat thyrotoxicosis or thyroid gland tumors. Diagnostic uses of radioiodine typically result in exposures by the oral or intravenous routes to 0.1–0.4 mCi (4–15 MBq) of ^{123}I or 0.005–0.01 mCi (0.2–0.4 MBq) of ^{131}I . These exposures correspond to approximate thyroid radiation doses of 1–5 rad (cGy) and 6–13 rad (cGy) for ^{123}I and ^{131}I , respectively. Cytotoxic doses of ^{131}I are delivered for ablative treatment of hyperthyroidism or thyrotoxicosis, exposures typically range from 5 to 15 mCi (185–555 MBq), which correspond to thyroid radiation doses of 5,000–10,000 rad (50–100 Gy). Higher exposures are used in the ablative treatment of thyroid gland cancer; 25–250 mCi (925–9,250 MBq), which correspond to thyroid radiation doses of 10,000–30,000 rad (100–300 Gy).

2.2 SUMMARY OF HEALTH EFFECTS

An extensive amount of literature is available on the effects of iodine on human physiology and health. The intense interest in iodine derives from early recognition of the necessity of appropriate amounts of iodine for maintenance of normal function of the thyroid gland and of awareness of diseases of the thyroid gland that are caused or affected by iodine intake. The prevalence of thyrotoxicosis (the clinical outcome of uncontrolled hyperthyroidism) has been estimated to be approximately 0.5%, and that of hypothyroidism is of a similar magnitude. Research directed at understanding the epidemiology, pathophysiology, and therapeutic strategies for these relatively common diseases have given way to a fairly comprehensive, although not complete, understanding of the role of iodine in thyroid gland physiology and the related health consequences and risks associated with excessive or inadequate iodine intake. The development of radiologic strategies for treating thyrotoxicosis, as well as studies of the

2. RELEVANCE TO PUBLIC HEALTH

thyroid gland as a target for internal exposures to atmospheric radioactive fallout, have further complemented our understanding of iodine toxicity as it relates to exposures to radioactive isotopes of iodine.

This profile does not attempt to summarize in detail all of the studies relevant to iodine toxicity, as to do so would require several volumes. Instead, the focus is on literature that identifies the lowest observable exposure levels associated with iodine toxicity in humans. Where applicable, relevant studies in animals are summarized, particularly when such studies have identified potential targets of toxicity not already documented in humans or for which adequate dose-response information does not exist for humans. This strategy leads to a focus on the thyroid gland as the primary and most sensitive target of iodine for both chemical and radiologic toxicity. This is not surprising given that avid uptake of absorbed iodine by the thyroid gland results in approximately 90% of the body iodine content residing in the thyroid gland (see Section 3.3, Toxicokinetics). Adverse effects on a wide variety of other organ systems can result from disorders of the thyroid gland, including disturbances of the skin, cardiovascular system, pulmonary system, kidneys, gastrointestinal tract, liver, blood, neuromuscular system, central nervous system, skeleton, male and female reproductive systems, and numerous endocrine organs, including the pituitary and adrenal glands. Although these secondary effects are noted in the profile, they are not discussed in detail and the reader is referred to authoritative references on these subjects for further information.

An important consideration in interpreting the iodine toxicology literature is that the effect of an increase in iodine intake will depend, in part, on the preexisting background dietary intake and the associated physiological adaptations to background intake. The response to an upward excursion in intake may be quite different in individuals who have adapted to either low dietary or high dietary intake. Examples of this are described in appropriate sections of this report (e.g., Section 3.2.2.2). In this profile, the term molecular iodine is used to refer to I_2 ; the term *iodide* is used to refer to the anion, I^- , the term iodate is used to refer to the anion IO_3^- , and the term *iodine* is used to refer to the element in any form, usually when the form was not specified in the literature being summarized, or where the form is not relevant to the discussion. From a physiological perspective, regardless of the form of iodine that is absorbed after an exposure, iodide is the form of iodine that is taken up into the thyroid gland, and effects from exposures to iodine ultimately derive from exposure of the gland to iodide. A more important toxicological distinction is that, unlike iodide, molecular iodine (I_2) is a relatively strong oxidizing agent and has the potential to produce injuries related to redox reactions with proteins. This is the primary basis for the use of I_2 as a topical antiseptic and antimicrobial disinfectant for drinking water.

The health effects of exposure to radioiodine derive from the emission of beta and gamma radiation. Radioiodine that is absorbed into the body quickly distributes to the thyroid gland and, as a result, the tissues that receive the highest radiation doses are the thyroid gland and surrounding tissues (e.g.,

2. RELEVANCE TO PUBLIC HEALTH

parathyroid gland). Tissues other than the thyroid gland can accumulate radioiodine, including salivary glands, gastric mucosa, choroid plexus, mammary glands, placenta, and sweat gland. Although these tissues may also receive a radiation dose from internal radioiodine, the thyroid gland receives a higher radiation dose. The radiation dose to the thyroid gland from absorbed radioiodine varies with isotope and its radiation emission properties (e.g., type of radiation, energy of emission, effective radioactive half-life). A comparison of the doses delivered to the thyroid gland from a few of the isotopes of iodine are compared in Table 2-1. The highest total doses are achieved with ^{131}I , whereas the highest dose rates (rad/hour) are delivered from ^{132}I .

Endocrine Effects. The principle direct effects of excessive iodine ingestion on the endocrine system are on the thyroid gland and regulation of thyroid hormone production and secretion. Adverse effects on the pituitary and adrenal glands derive secondarily from disorders of the thyroid gland. Effects of iodine on the thyroid gland can be classified into three types: hypothyroidism, hyperthyroidism, and thyroiditis. Hypothyroidism refers to the diminished production of thyroid hormone leading to clinical manifestations of thyroid insufficiency. This can occur with or without goiter, a functional hypertrophy of the gland that occurs in response to thyroid stimulating hormone (TSH) and suppressed thyroid hormone production. Typical biomarkers of hypothyroidism are a depression in the circulating levels of thyroxine (T_4) and/or triiodothyronine (T_3) below their normal ranges. This is usually, but not always, accompanied by an elevation of TSH (also known as thyrotropin) above the normal range. Hyperthyroidism is an excessive production and/or secretion of thyroid hormones. The clinical manifestation of abnormally elevated circulating levels of T_4 and/or T_3 is thyrotoxicosis. Thyroiditis refers to an inflammation of the gland, which is often secondary to thyroid gland autoimmunity. The above three types of effects of iodine can occur in children and adults, in fetuses exposed *in utero*, or in infants exposed during lactation. The primary effect of iodide excess in the fetus is goiter formation secondary to a suppression of thyroid hormone production and an elevation in TSH levels.

Measurements of serum levels of thyroid hormones and TSH are often used as biomarkers of hypothyroidism and hyperthyroidism in toxicology and epidemiology studies. In interpreting this literature in terms of human health risks, a distinction must be made between outcomes that have a high potential for producing clinical manifestations and those outcomes that are not clinically significant. In this profile, an observed decrease in circulating T_4 or T_3 levels or an increase in serum TSH level, within their respective normal ranges is referred to as *subclinical hypothyroidism*. Similarly, the term *subclinical hyperthyroidism* refers to a condition in which the circulating levels of T_4 or T_3 are elevated within their normal ranges. Typical normal ranges for these hormone levels are discussed in Section 3.8.2

An acute iodide excess can cause a decrease in thyroid hormone production in the thyroid gland; this effect is referred to as the *Wolff-Chaikoff effect*. In most people, this is followed by a return to normal

2. RELEVANCE TO PUBLIC HEALTH

Table 2-1. Thyroid Doses and Dose Rates for Various Isotopes of Iodine^a

Isotope	Percent of dose from beta radiation	Effective half-life in the thyroid (hours)	Mean range of beta-radiation in thyroid (mm)	Total dose from 1 mCi in the thyroid (rad)	Average dose rate of 10 rad from 1 mCi in the thyroid (rad/hour)
¹²³ I	77	13	0.1	76	3.7
¹²⁵ I	73	866	0.01	3,747	3.0
¹³¹ I	94	177	0.4	5,627	22
¹³² I	90	2.3	1.7	199	59
¹³³ I	96	20	1.3	1,355	46
¹³⁵ I	90	6.7	1.1	434	45

^a from Maxon and Saenger 2000

2. RELEVANCE TO PUBLIC HEALTH

levels of production, referred to as *escape* from the Wolff-Chaikoff effect, without clinically significant a change in circulating hormone levels. Escape is thought to be the result of down regulation of the iodine transport mechanism in the thyroid gland (see Section 3.4.3.2 for further details on the Wolff-Chaikoff effect). An acute or chronic excess of iodide can also decrease circulating T₄ and T₃ levels and induce a hypothyroid state. These effects are thought to involve the inhibition of the release of T₄ from the thyroid gland and/or inhibition of extrathyroidal production of T₃. Most iodine-induced hypothyroidism is transient, although T₄ replacement may be required in some patients. Hypothyroidism is thought to occur primarily in *susceptible* individuals who fail to escape from the inhibitory effect of large doses of iodide that produce the *Wolff-Chaikoff effect*. Susceptible individuals includes fetuses and newborn infants, patients who have autoimmune thyroiditis, patients with Graves' disease previously treated with iodine or antithyroid drugs, women who have had postpartum thyroiditis, or those who have had subacute thyroiditis. Spontaneous recovery usually occurs within 2–3 weeks, although some individual may develop permanent thyroiditis.

Several studies have examined the acute and intermediate-duration effects of increased intake of iodine on thyroid hormone status of adults. Acute iodine exposures (1,500 µg/day) have been shown to produce reversible thyroid gland hypertrophy, in addition to suppression of hormone production. The results of epidemiological studies suggest that chronic exposure to excess iodine can result in or contribute to hypothyroidism, with or without goiter, in children (1,150 µg/day, 29 µg/kg/day) and elderly adults (160–800 µg/day, 4–12 µg/kg/day). Several studies have found an increased prevalence of hypothyroidism in residents of areas of Japan where dietary iodine intake is extraordinarily high as a result of consumption of seaweeds with a high iodine content (13 mg/day, 0.22 mg/kg/day). Populations that are iodine deficient and, in particular, those that include people who have goiter, appear to be particularly sensitive to an increase in their iodine intake. For example, iodine supplementation (200–400 µg/day, 3–6 µg/kg/day) for treatment of endemic goiter has been associated with thyroid dysfunction, including thyroid autoimmunity.

People who have autoimmune thyroid disease may be at increased risk of developing thyroid dysfunction when exposed to excess iodide. Euthyroid patients who were diagnosed with Hashimoto's thyroiditis and who were positive for antithyroid (thyroid peroxidase) antibodies developed subclinical hypothyroidism after oral doses of 375 µg/day (4.5 µg/kg/day) for 6 months or clinical hypothyroidism after exposures to 180 mg I/day (2.6 mg/kg/day) for 6 weeks, more than 1,000 times the RDA. In general, iodine excess accelerates autoimmune thyroiditis in autoimmune-prone individuals, whereas iodine deficiency attenuates thyroiditis.

The clinical case literature demonstrates that doses of iodide exceeding 200 mg/day (2.8 mg/kg/day) given to a mother during pregnancy can result in congenital goiter and hypothyroidism in the newborn

2. RELEVANCE TO PUBLIC HEALTH

infant. An iodine-deficient status of the mother can lead to goiter in the fetus and neurodevelopmental impairment of the fetus. Adequate iodine supplementation early in pregnancy can correct the deficiency and prevent maternal and neonatal goiter formation. Thyroid dysfunction was not detected in newborns of mothers who received oral doses of 3–4 µg/kg/day during pregnancy for the purpose of correcting or preventing potential iodine deficiency and for the management of Graves' disease during pregnancy (Graves' disease is a hyperthyroid state in which autoantibodies to the TSH receptor are produced and act on the TSH receptor to stimulate the gland to produce thyroid hormones).

Oral exposure to excess iodide can, under certain circumstances, induce hyperthyroidism and thyrotoxicosis. The epidemiological and clinical literature suggest that hyperthyroidism occurs most often in people who have a previous history of iodine deficiency, goiter, or thyroid diseases such as postpartum thyroiditis or Graves' disease. What has been referred to as an *epidemic* of hyperthyroidism occurred in the midwestern United States between the years 1926 and 1928. Clinical records suggest that the incidence of mortality from hyperthyroidism increased substantially during this period; for example, in Detroit, mortality from hyperthyroidism increased from approximately 2–4 deaths per 100,000 to approximately 11 deaths per 100,000. Although there is considerable debate about the origins of the epidemic, the advent of aggressive supplementation of the diet with iodide in midwestern endemic goiter areas has been implicated as a contributing factor. More recent and more rigorous epidemiologic designs have been applied to several populations in which dietary iodide was supplemented as a prophylaxis for iodine deficiency and goiter. These studies confirm that iodide supplementation of iodide-deficient diets, to achieve intakes in the range of 3–7 µg/kg/day, does indeed result in a detectable increase in incidence of hyperthyroidism. Cases of iodine-induced hyperthyroidism in people who were euthyroid and without apparent thyroid disease have also been reported; however, only a few have provided dose information, suggesting effects after oral doses of 3–1,440 mg/day (0.05–23 mg/kg/day) for 6 months.

Extensive clinical use of radioiodine, principally ^{123}I , ^{124}I , ^{125}I , and ^{131}I , for diagnostic purposes and for treatment of thyrotoxicosis has provided a wealth of information on the effects of relatively high acute exposures on thyroid gland function. Radioiodine is cytotoxic to the thyroid gland at high radiation doses and produces hypothyroidism when doses to the thyroid gland exceed 25 Gy (2,500 rad). Thyroid gland doses of approximately 300 Gy (30,000 rad) can completely ablate the thyroid gland and result in hypothyroidism. This dose is achieved with an acute exposure of approximately 25–250 mCi (0.9–9 GBq). Such high dosages are used to ablate thyroid remnants after surgery for thyroid cancer. Cytotoxic doses of ^{131}I can also produce dysfunction of the parathyroid gland, which can receive a radiation dose from β emission of ^{131}I in the adjacent thyroid gland.

Clinical cases have been reported in which congenital hypothyroidism occurred in newborn infants after maternal exposures to high doses of ^{131}I for treatment of thyroid gland tumors. However, the complex

2. RELEVANCE TO PUBLIC HEALTH

clinical picture and pharmacotherapy of the mothers for their thyroid condition during pregnancy makes direct associations between the radioiodine exposure and clinical outcomes of the newborn unclear. Exposure in these cases ranged from 11 to 77 mCi (407–2,850 MBq). Two studies that reviewed the thyroid status of larger sets of infants (37 or 73) born to patients who received ^{131}I for ablative treatment of thyroid cancer 2–10 years (mean, 5.3 years) prior to pregnancy (i.e., exposure occurred before conception and fetal development) found no thyroid gland disorders. The maternal ^{131}I exposures ranged from 1 to 17 GBq (50–400 mCi); the mean exposure was 3.5–4.4 GBq (100–120 mCi).

A large amount of epidemiological literature exists on the health outcomes in populations who were exposed to environmental releases of radioiodine. These include (1) releases from explosions of nuclear bombs such as the Marshall Islands BRAVO test, the largest U.S. detonation (15 megaton), and from the Nevada Test Site; (2) accidental releases from nuclear power plants such as the Chernobyl explosion and fire; and (3) releases from nuclear fuel production facilities such as the Hanford Nuclear Site (Table 2-2). In general, releases of these types result in mixed exposures to a variety of radioisotopes and to radiation doses from both external and internal exposure. However, doses from radioiodine that are significant to health derive largely from internal exposure as a result of uptake of radioiodine into the thyroid gland (see Section 3.4.2.2). The relative contribution of the inhalation and oral pathways can be expected to vary depending on the duration of the release and the duration of human access and contact to the sites of contamination. In the so-called *BRAVO cohort*, which has been studied extensively (see Section 3.3.1 for a more detailed discussion), inhalation may have been a more significant contributor to the internal radioiodine dose because the subjects comprising the cohort were evacuated from the site of major contamination within 2 days after the release of radioiodine to the atmosphere; this would have limited their dietary exposures. Nevertheless, estimates of inhalation intakes of airborne radioactivity amounted to <1% of the total intake estimated based on measurements of ^{131}I in urine, suggesting a substantial contribution from other routes. In nursing infants, exposure would have continued from ingestion of contaminated breast milk. The Chernobyl cohorts had access to contaminated areas and contaminated foods (e.g., locally harvested produce and goat and cow milk) for weeks to months after the accident. The thyroid radiation doses in this population are thought to have been dominated by the oral exposure pathway. Epidemiological studies of the Nevada Test Site detonations and releases from the Hanford Nuclear Site have focused on subjects who were potentially exposed through the dietary pathway as a result of repeated releases during periods of 7 or 13 years, respectively.

Radiation doses to the thyroid gland (external and internal) in the most highly exposed individuals after the Marshall Islands BRAVO test is estimated to have ranged from 0.3 to 20 Gy (30–2,000 rad). External radiation is estimated to have contributed approximately 4–16% or 10–50% of total thyroid dose, depending on the location of the individual with respect to the blast. Thyroid gland outcomes have been assessed periodically since the BRAVO test in 1954. Cases of thyroid gland disorders began to be

2. RELEVANCE TO PUBLIC HEALTH

Table 2-2. Releases from Radioiodine-producing Events

Source	¹³¹ I Released (PBq) ^a	Reference
All nuclear bomb tests	650,000	Gonzalez 1998
Nevada Test Site nuclear bomb tests	5,500	NCI 1997
Chernobyl power plant accident	3,200	UNSCEAR 2000
Hanford Nuclear Site nuclear fuel processing-related releases	27	CDC 1999
Three Mile Island power plant accident	0.0004–0.0011	NRC 1995

^a1 PBq=27,000 Ci

2. RELEVANCE TO PUBLIC HEALTH

detected in the exposed population in 1964, 10 years after the BRAVO test, particularly in exposed children; these included cases of apparent growth retardation, myxedema (typical of hypothyroidism), and thyroid gland neoplasms. Collectively, the various health assessments and studies of the so-called *BRAVO cohort* have revealed dose-related abnormally high elevations in serum concentrations of TSH, characteristic of hypothyroidism. Among exposed children who were 1-year-old at the time of the BRAVO test and who received an estimated thyroid radiation dose exceeding 1,500 rad (or 15 Gy), 83% had serum concentrations of TSH >5 mU/L; thyroid nodularity was found in 67–81% of the most highly exposed group, and thyroid cancer was discovered in 6% of the most an apparent highly exposed group.

The 1986 explosion and fire at the nuclear power plant at Chernobyl in the Ukraine resulted in the release of airborne radionuclides to the surrounding regions and contamination of soil, food, and surface water. Several different exposure populations have been characterized that vary considerably in exposure levels and radiation doses received. These include emergency response workers who received the highest acute radiation doses, early evacuees from areas near the reactor (generally within 30 km of the reactor), and people who continued to inhabit contaminated areas outside the evacuation zone. The radiation exposures to the general population (i.e., evacuees and people who continued to inhabit contaminated areas) were attributed largely to isotopes of cesium (e.g., ^{137}Cs), which accounted for approximately 90–98% of the external radiation dose. However, radioiodine is estimated to have contributed approximately 50% of the total lifetime committed effective radiation dose for children born in the region in 1986, and approximately 80% of the radiation dose received during the first year after the release. Estimates of thyroid radiation doses to the general population suggest that doses were highest in children who were younger than 1 year of age at the time of the release. The highest estimated doses were received within the 30-km evacuation zone; median doses ranged from 2.3 Gy (250 rad) at age <1 year to 0.4 Gy (40 rad) in adolescents and adults. Estimated median doses received in populations residing 100–200 km from the plant (e.g., Mogilev region) were <0.3 Gy (30 rad) for all age groups. Thyroid screening programs and epidemiological studies conducted after the Chernobyl accident have revealed a dose-related elevated prevalence of thyroid nodules and thyroid cancer in children of the Belarus and Ukraine regions, apparent approximately 4 years after the Chernobyl accident. These effects have been associated with thyroid radiation doses of 0.3–1 Gy (30–100 rad). In both Belarus and the Ukraine, the highest rates of childhood thyroid cancer have occurred in areas where exposure to other industrial contaminants are likely to have occurred and where there is evidence for widespread iodine deficiency. These factors may have affected the early appearance of thyroid cancer after the accident, when vigorous public health screening programs for thyroid abnormalities were initiated. The incidence of thyroid cancer prior to the accident in these areas was poorly documented.

2. RELEVANCE TO PUBLIC HEALTH

Immunological and Lymphoreticular Effects. Excess iodide intake may be a contributing factor in the development of autoimmune thyroiditis in susceptible individuals, which can result in hypothyroidism or hyperthyroidism (associated with Graves' disease). Autoimmune thyroiditis is an inflammation of the thyroid gland that can lead to fibrosis of the gland, follicular degeneration, follicular hyperplasia, and hypothyroidism. IgG autoantibodies to thyroglobulin and thyroid peroxidase are a consistent feature of the disorder. Iodine appears to play an important role in autoimmune response, as human lymphocytes recognize and proliferate in response to iodinated human thyroglobulin, but not iodine-free thyroglobulin. In general, iodine excess accelerates autoimmune thyroiditis in autoimmune-prone individuals, whereas iodine deficiency attenuates thyroiditis. Several studies have been conducted of people who reside in endemic goiter areas and who received iodide supplementation. These studies suggest that iodine intakes of 230–420 µg I/day (3.3–6.0 µg/kg/day total intake) for 12 months can induce thyroid autoimmunity. However, other studies have not found increases in autoimmunity associated with iodine supplementation at doses of 1,150 µg/day (29 µg/kg/day). Studies using rats have shown that doses of 70–95 mg I/kg/day (in drinking water) for 8–12 weeks may increase the incidence of autoimmune thyroiditis in inbred strains of rats that develop spontaneous thyroid autoimmunity.

Larger scale assessments of thyroid autoimmunity have been conducted in the Marshall Islands, where exposures to ¹³¹I occurred as a result of fallout and contamination from test detonations of thermonuclear devices during the period 1946–1958. These studies have not revealed an elevated prevalence of thyroid autoimmunity relative to other populations. Studies of populations in the Belarus and Ukraine suggest a possible contribution of radioiodine exposure to an increased prevalence of thyroid autoimmunity following the Chernobyl accident. Cases of autoimmune hyperthyroidism, with serum antibodies to the TSH receptor, have occurred after exposures to higher levels of ¹³¹I for ablative treatment of hyperthyroidism. No relationship was found between the prevalence or incidence of autoimmune thyroiditis and exposure to radioiodine associated with bomb tests at the Nevada Test Site.

Oral exposure to excess iodide can produce allergic reactions in sensitive subjects. The reactions include urticaria (hives), acneiform skin lesions (ioderma), and fevers. Cases of more serious reactions involve angioedema (localized edema), vasculitis, peritonitis and pneumonitis, and complement activation. Both humoral and cell-mediated immune responses are thought to be involved. In general, reactions to iodide have occurred in association with repeated oral doses of iodide 300–1,600 mg I/day (5–23 mg/kg/day). However, in many of these cases, preexisting disease and related drug therapy may have contributed to the reaction to the iodine; thus, the dose-response relationship for ioderma in healthy people remains highly uncertain.

2. RELEVANCE TO PUBLIC HEALTH

Gastrointestinal Effects. Ablative treatment of thyroid cancers with ^{131}I has been associated with inflammation of the salivary glands (sialadenitis) in humans. Salivary glands express a transport protein, the sodium-iodine symport (NIS), which is also present in the thyroid gland, where it functions to transport iodide into the gland for hormone synthesis. Salivary glands can accumulate iodide in saliva at concentrations considerably above that in serum (see Sections 3.4.2.2 and 3.5.1). Exposures in reported cases of ^{131}I -induced sialadenitis ranged from 100 to 300 mCi (3.7–11 GBq). Sialadenitis usually occurred within a few days or weeks of exposure and had a duration of several weeks to 2–3 years.

Neurological Effects. Exposure to excess iodine has been shown to produce subclinical hypothyroidism, which in certain individuals sensitive individuals, may take the form of hypothyroidism. Sensitive populations include fetuses, newborn infants, and individuals who have thyroiditis or Graves' disease, many of whom have abnormal autoimmune disorders (see Section 3.2.2.2, Endocrine Effects). Of these iodine-induced forms of hypothyroidism, that occurring in the fetus or newborn infant has the greatest potential for producing neurological effects. This is because thyroid hormones are essential to the development of the neuromuscular system and brain. An iodine-induced hypothyroid state can result in delayed or deficient brain and neuromuscular development of the newborn. Iodine-induced hypothyroidism in an older child or adult would be expected to have little or no deleterious effects on the neuromuscular system. Exposure of a fetus to large amounts of radioiodine would result in thyroid tissue ablation and in similar delayed brain and neuromuscular development, if the hypothyroid state was not corrected (e.g., with hormone replacement therapy) after birth.

Exposure to excess iodine can also produce hyperthyroidism in sensitive individuals (see Section 3.2.2.2, Endocrine Effects). These include people who are initially iodine deficient, those who have thyroid disease, including Graves' disease, who have been treated with antithyroid drugs, people who have had postpartum thyroiditis, and those who have developed thyrotoxicosis from amiodarone or interferon-alpha treatments. Patients who develop thyrotoxicosis may experience neuromuscular disorders, including myopathy, periodic paralysis, myasthenia gravis, peripheral neuropathy, tremor, and chorea.

Developmental Effects. Although iodine excess may result in hypothyroidism, iodine deficiency is far more likely to cause prenatal and postnatal hypothyroidism and be associated with neurologic injury leading to cretinism, a developmental effect (see Section 3.2.2.2, Endocrine Effects). Thyroid hormone deficiency from any cause at critical times of development may result in severe mental retardation, neurologic abnormalities, growth retardation, or abnormal pubertal development.

Congenital hypothyroidism secondary to thyroid ablation has been reported subsequent to maternal exposure to ablative doses of ^{131}I . In one case, an infant became hypothyroid after his mother received 99 mCi (3.7 GBq) of ^{131}I during her sixth week of pregnancy. Growth retardation was also observed in

2. RELEVANCE TO PUBLIC HEALTH

some children who were exposed to radioiodine in the Marshall Island BRAVO cohort, early after the bomb test. Studies are suggestive of possible extra-thyroidal developmental effects of radioiodine following maternal exposures to ablative doses of ^{131}I received 2–10 years prior to pregnancy. Observed outcomes that may or may not have been related to the ^{131}I exposures included low birth weights with subsequent normal growth patterns, tetralogy of Fallot (pulmonic stenosis, atrial septal defect, and right ventricular hypertrophy), hypoparathyroidism, Down's syndrome, and cardiac anomalies. The maternal ^{131}I exposures ranged from 1 to 17 GBq (20–460 mCi). Studies of pregnancy outcomes in Belarus and Ukraine populations after the Chernobyl accident are suggestive of possible developmental effects related to radiation exposures.

Exposure to excess iodine can also produce hyperthyroidism in sensitive individuals (see Section 3.2.2.2, Endocrine Effects). Growth acceleration occurs in childhood hyperthyroidism, from any cause, which is thought to be related to changes in pituitary regulation of growth.

Reproductive Effects. Exposure to excess iodine may produce hypothyroidism or hyperthyroidism (see Section 3.2.2.2, Endocrine Effects) and could cause disruption of reproductive function, secondary to thyroid gland dysfunction. Hypothyroidism can produce changes in the menstrual cycle in humans, including menorrhagia (excessive uterine bleeding) and anovulation (no ovulation). Spontaneous abortions, stillbirths, and premature births have also been associated with hypothyroidism. Reproductive impairments associated with hyperthyroidism include amenorrhea and alterations in gonadotropin release and sex hormone-binding globulin (SHBG), and associated changes in the levels and metabolism of steroid hormones in both females and males.

Clinical follow-up studies of pregnancies in patients who received ^{131}I (1–17 GBq, 20–460 mCi) for ablative treatment of thyroid cancer 2–10 years (mean, 5.3 years) prior to pregnancy have not shown evidence of effects on reproductive success. However, clinical cases of impaired testicular function following exposures to ^{131}I for ablative treatment of thyroid cancer in men have been reported. Observed effects included low sperm counts, azospermia (absence of spermatozoa), and elevated serum concentrations of follicle stimulating hormone (FSH), which persisted for more than 2 years. Exposures to radioiodine ranged from 30 to 1,335 mCi (1.1–49.5 GBq). In Belarus and Ukraine populations after the Chernobyl accident, pregnant women who resided in heavily exposed areas (including exposures to other industrial contaminants) appeared to be at risk for development of toxemia, renal insufficiency, and anemia.

2. RELEVANCE TO PUBLIC HEALTH

Cancer. The relationship between iodide intake and thyroid cancer has been examined in several large-scale epidemiology studies. The results of these studies suggest that increased iodide intake may be a risk factor for thyroid cancer in certain populations, particularly in populations in iodine-deficient, endemic goiter regions. Not all studies have found an increased risk of cancer; however, a recurrent observation is an apparent shift in the histopathology toward a higher prevalence of papillary cancer after increased iodine intake in otherwise iodine-deficient populations. Two studies found a significant excess of thyroid gland cancer in populations from endemic goiter regions whose diets were supplemented to achieve approximate iodine intakes of 3.5 µg/kg/day.

The thyroid gland receives the highest radiation dose of any organ or tissue following internal exposure to radioiodine (see Section 3.4.2.2, Toxicokinetics), and therefore, cancer of the thyroid gland is a major cancer concern associated with radioiodine exposures. Cancer morbidity and mortality among populations who received exposures to radioiodine have been examined in several large-scale epidemiology studies. In general, these studies fall into several categories that can be distinguished by the sources of exposure and estimated radiation doses to the thyroid gland and include (see Table 3-3): (1) high exposures and doses (10–20 mCi, 370–740 MBq; >10,000 rad, >100 Gy) achieved when ¹³¹I is administered to treat hyperthyroidism (higher exposures are used in treatment of thyroid cancer); (2) lower exposures and doses (40–70 µCi, 1.5–2.6 MBq; 80–130 rad, cGy) associated with clinical administration of ¹³¹I for diagnosis of thyroid gland disorders; (3) doses from exposures to fallout from nuclear bomb tests (BRAVO test, 300–2,000 rad, cGy; Nevada Test Site, 1–40 rad, cGy); (4) doses from exposures to releases from nuclear power plant accidents (Chernobyl, 1–200 rad, cGy), and (5) exposures from operational releases from nuclear fuel processing plants (Hanford Nuclear Site, 0.0001–284 rad, cGy).

The relatively high and acutely cytotoxic radiation doses to the thyroid gland that are achieved in the treatment of thyroid gland disorders, and the related outcomes on the thyroid, are virtually irrelevant to predicting outcomes from the much lower environmental exposures that occur in most U.S. populations. Nevertheless, these studies have revealed that, even at high exposures (3–27 mCi, 111–999 MBq) and thyroid gland doses (60 Gy, 6,000 rad), significant risks for cancers in organs other than the thyroid gland have not been consistently detected when the study designs control for other treatments administered to the patients. Studies of diagnostic doses of radioiodine have not consistently revealed significant risks of thyroid or other cancers; those that have, however, found significantly elevated risks only in patients who were administered the radioiodine for diagnosing a suspected thyroid gland tumor. In general, studies of the outcomes of medical uses of radioiodine involve subjects who were exposed as adults. Studies of thyroid cancers and external radiation exposure have found a strong age dependence between thyroid radiation dose and thyroid cancer. Risk is substantially greater for radiation doses received prior to age 15 years when compared to risks for doses received at older ages. This same general trend in age-

2. RELEVANCE TO PUBLIC HEALTH

dependence would be expected for internal exposures to radioiodine, thus, studies of adult exposures to radioiodine may not be directly applicable to predicting outcomes from exposures to children. Studies of populations potentially exposed to radioiodine (0.09–3.2 Gy, 9–325 rad) as a result of nuclear bomb tests at the Nevada Test Site are suggestive, but not conclusive, of a possible association between radioiodine exposures and thyroid cancer. The National Research Council concluded that, because of uncertainties related to dose reconstruction and epidemiological analyses of the Nevada Test Site experience, the currently available information is not adequate to determine the extent to which the bomb tests in Nevada increased the incidence of thyroid cancer. A case-control study of thyroid cancers among children in Belarus provides reasonably strong evidence for the contribution of higher level radioiodine exposure and thyroid cancers diagnosed after the Chernobyl accident.

Breast cancer is also a concern with exposures to high levels of radioiodine after ablative therapy for hyperthyroidism because the breast expresses NIS and can transport and accumulate iodide (see Sections 3.4.4.2 and 3.5.1, Distribution). However, the epidemiological literature to date has not implicated such exposures as a significant risk factor for breast cancer.

2.3 MINIMAL RISK LEVELS

Inhalation MRLs

- C An MRL could not be derived for iodine because of a lack of information on dose-response relationships for the inhalation pathway.

Oral MRLs

- C An MRL of 0.01 mg/kg/day has been derived for acute-duration oral exposure (1–14 days) to iodine.

The acute-duration MRL is based on a no-observed-adverse-effect-level (NOAEL) of 0.024 mg/kg/day in healthy adult humans. Although the NOAEL is derived from acute studies of health adults, supporting studies indicate that the NOAEL would be applicable to children and elderly adults. On this basis, an uncertainty factor is not needed adjust the NOAEL to account for human variability in sensitivity.

Although elevated serum concentrations of TSH and decreased serum concentrations of thyroid hormone (T_4 and T_3) in healthy adults who had no history of thyroid disease or detectable antithyroid antibodies, hormone levels were within the normal range for healthy adults. Furthermore, the hormone levels reverted to pretreatment levels when the iodine dosage was withdrawn.

2. RELEVANCE TO PUBLIC HEALTH

Healthy euthyroid adults (9 males, 9 females) who had no history of thyroid disease or detectable antithyroid antibodies received daily oral doses of 250, 500, or 1,500 µg I/day as sodium iodide for 14 days. Based on 24-hour urinary excretion of iodide prior to the iodide supplement, the background iodine intake was estimated to be approximately 200 µg/day; thus, the total iodide intake was approximately 450, 700, or 1,700 µg I/day (approximately 0.0064, 0.01, or 0.024 mg/kg/day, assuming a 70-kg body weight). Subjects who received 1,700 µg/day (0.024 mg/kg/day) had significantly depressed (5–10%) serum concentrations of TT₄, FT₄, and TT₃ compared to pretreatment levels, and serum TSH concentrations were significantly elevated (47%) compared to pretreatment values. Hormone levels were within the normal range during treatment. In this same study, nine females received daily doses of 250 or 500 µg I/day for 14 days (total intake was approximately 450 or 700 µg/day; 0.0064 or 0.010 mg/kg/day) and there were no significant changes in serum hormone concentrations.

In similar type of study, healthy, euthyroid, adult males (n=10) received daily oral doses of 500, 1,500, or 4,500 µg I/day (as sodium iodide) for 14 days. Based on 24-hour urinary excretion of iodide prior to the iodide supplement of 250–320 µg/day, the total estimated intakes were 300, 800, 1,800, or 4,800 µg/day or approximately 0.004, 0.011, 0.026, or 0.069 mg/kg/day. There were no effects on serum thyroid hormone or TSH concentrations at the 800 µg/day intake (0.011 mg/kg/day); however, intakes of 1,800 or 4,800 µg I/day (0.026 or 0.064 mg/kg/day) produced small (10%) but significant, transient decreases in serum TT₄ and FT₄ concentrations and an increase (48%) in serum TSH concentration, relative to the pretreatment values.

Although the acute NOAEL is derived from acute studies of health adults, supporting studies indicate that the NOAEL would be applicable to children and elderly adults. On this basis, an uncertainty factor is not needed adjust the NOAEL to account for human variability in sensitivity. In the Chow et al. study, 30 healthy elderly adult females, without evidence of thyroid peroxidase antibodies (TPA), received daily doses of 500 µg I/day (as potassium iodide) for 14 or 28 days. Serum concentrations of FT₄ were significantly decreased and serum TSH concentrations were significantly elevated in the women who received the iodide supplements, relative to a placebo control group. On average, the magnitude of the changes did not produce clinically significant depression in thyroid hormone levels; however, five subjects had serum TSH concentrations that exceeded 5 mU/L. The subjects had a lower dietary iodine intake than those in the Gardner et al. study, approximately 72–100 µg/day, based on urinary iodide measurements. Therefore, the total iodide intake was approximately 600 µg/day or 0.0086 mg/kg/day, essentially the same as the acute NOAEL in healthy adults based on Gardner et al. and Paul et al.

In the Boyages et al. study, thyroid status was compared in groups of children, ages 7–15 years, who resided in two areas of China where drinking water iodide concentrations were either 462 µg/L (n=120) or 54 µg/L (n=51). Although the subjects were all euthyroid with normal values for serum thyroid

2. RELEVANCE TO PUBLIC HEALTH

hormones and TSH concentrations, TSH concentrations were significantly higher in the high iodine group. The prevalence and severity of goiter in the population were evaluated, the latter based on a goiter severity classification scale (Grade 0, no visible goiter; Grade 1, palpable goiter that is not visible when the neck is not extended; Grade 2, palpable and visible goiter when the neck is not extended). The high iodide group had a 65% prevalence of goiter and a 15% prevalence of Grade 2 goiter compared to 15% for goiter and 0% for Grade 2 goiter in the low iodine group. Urinary iodine was 1,236 $\mu\text{g I/g creatinine}$ in the high iodine group and 428 $\mu\text{g I/g creatinine}$ in the low iodine group. Assuming a body weight of 40 kg and lean body mass of 85% of body weight, the above urinary iodine/creatinine ratios are approximately equivalent to iodine excretion rates, or steady state ingestion rates of 1,150 (0.029 mg/kg/day) and 400 $\mu\text{g/day}$ (0.01 mg/kg/day) in the high and low iodide groups, respectively. The NOAEL of 0.01 mg/kg/day from this study is the same as the acute NOAEL based on Gardner et al. and Paul et al.

The MRL is higher than the National Research Council RDA of 150 $\mu\text{g/day}$ (0.0021 mg/kg/day for a 70-kg adult), with additional allowances of 25 $\mu\text{g/day}$ (0.0025 mg/kg/day) and 50 $\mu\text{g/day}$ (0.0029 mg/kg/day) during pregnancy and lactation, respectively.

- C An MRL of 0.01 mg/kg/day has been derived for chronic-duration (>364 days) oral exposure to iodine.

The chronic-duration MRL is based on a NOAEL of 0.01 mg/kg/day and a lowest-observed-adverse-effect level (LOAEL) of 0.029 mg/kg/day for subclinical hypothyroidism in healthy human children. An uncertainty factor is not needed adjust the NOAEL to account for human variability in sensitivity because the NOAEL is based on a sensitive end point in children, a sensitive subpopulation. Supporting studies indicate that the NOAEL would be applicable to elderly adults who may represent another sensitive subpopulation. The chronic MRL was based on a chronic human study; however, since the chronic MRL is the same as the acute MRL (0.01 mg/kg/day), it is also applicable to intermediate-duration exposures.

Although serum concentrations of TSH were elevated, they remained within the normal range for children. Thyroid gland enlargement, however, was observed in children who had no history of thyroid disease or detectable antithyroid antibodies. Hormone levels were within the normal range for healthy children; therefore, these dosages did not induce clinical hypothyroidism. The slight thyroid enlargement can be considered a less-serious LOAEL, not indicative of functional impairment. Thyroid status was compared in groups of children, ages 7–15 years, who resided in two areas of China where drinking water iodide concentrations were either 462 $\mu\text{g/L}$ (n=120) or 54 $\mu\text{g/L}$ (n=51). Urinary iodine was 1,236 $\mu\text{g I/g creatinine}$ in the high iodine group and 428 $\mu\text{g I/g creatinine}$ in the low iodine group. Assuming a body weight of 40 kg and lean body mass of 85% of body weight, the above urinary iodine/creatinine ratios are approximately equivalent to iodine excretion rates, or steady state ingestion rates of

2. RELEVANCE TO PUBLIC HEALTH

1,150 (0.029 mg/kg/day) and 400 µg/day (0.010 mg/kg/day) in the high and low iodide groups, respectively. Although the subjects were all euthyroid with normal values for serum thyroid hormones and TSH concentrations, TSH concentrations were significantly higher (33%) in the high iodine group. The high iodide group had a 65% prevalence of goiter and a 15% prevalence of Grade 2 goiter compared to 15% for goiter and 0% for Grade 2 goiter in the low iodine group.

Although the acute NOAEL is derived from acute studies of children, supporting studies indicate that the NOAEL would be applicable to elderly adults. On this basis, an uncertainty factor is not needed adjust the NOAEL to account for human variability in sensitivity. In the Chow et al. study, 30 healthy elderly adult females, without evidence of TPA, received daily doses of 500 µg I/day (as potassium iodide) for 14 or 28 days. Serum concentrations of FT₄ were significantly decreased and serum TSH concentrations were significantly elevated in the women who received the iodide supplements, relative to a placebo control group. On average, the magnitude of the changes did not produce clinically significant depression in thyroid hormone levels; however, five subjects had serum TSH concentrations that exceeded 5 mU/L. The pre-existing dietary iodine intake was approximately 72–100 µg/day, based on urinary iodide measurements. Therefore, the total iodide intake was approximately 600 µg/day or 0.0086 mg/kg/day, essentially the same as the acute NOAEL in healthy adults based on Boyages et al. and Li et al.

Szabolcs et al. studied elderly nursing home residents in the Carpathian Basin and revealed a prevalence of hypothyroidism that increased with increasing iodine intake. Subjects were from one of three regions where, based on reported urinary iodine levels of 72, 100, or 513 µg I/g creatinine, the iodine intakes were approximately 117, 163, or 834 µg/day (0.0017, 0.0023, or 0.012 mg/kg/day for low, n=119; moderate, n=135; or high intake, n=92, respectively). The prevalence of elevated serum TSH concentrations together with serum FT₄ concentrations below the normal range was 0.95, 1.5, and 7.6% in the low, moderate, and high iodine groups, respectively. If a prevalence of abnormal thyroid hormone levels of <5% is considered a NOAEL, than this study supports a NOAEL in elderly adults that is slightly below 0.012 mg/kg/day. Linear interpolation of the dose-prevalence data reported above yields an estimate of a 5% prevalence at an iodine intake of approximately 0.008 mg/kg/day.

The MRL is higher than the National Research Council RDA of iodine of 150 µg/day (0.0021 mg/kg/day for a 70-kg adult), with additional allowances of 25 µg/day (0.0025 mg/kg/day) and 50 µg/day (0.0029 mg/kg/day) during pregnancy and lactation, respectively.

3. HEALTH EFFECTS

3.1 INTRODUCTION

The primary purpose of this chapter is to provide public health officials, physicians, toxicologists, and other interested individuals and groups with an overall perspective on the toxicology of iodine. It contains descriptions and evaluations of toxicological studies and epidemiological investigations and provides conclusions, where possible, on the relevance of toxicity and toxicokinetic data to public health.

A glossary and list of acronyms, abbreviations, and symbols can be found at the end of this profile.

3.2 DISCUSSION OF HEALTH EFFECTS BY ROUTE OF EXPOSURE

To help public health professionals and others address the needs of persons living or working near hazardous waste sites, the information in this section is organized first by route of exposure (inhalation, oral, and dermal) and then by health effect (death, systemic, immunological, neurological, reproductive, developmental, genotoxic, and carcinogenic effects). These data are discussed in terms of three exposure periods: acute (14 days or less), intermediate (15–364 days), and chronic (365 days or more).

Levels of significant exposure for each route and duration are presented in tables and illustrated in figures. The points in the figures showing no-observed-adverse-effect levels (NOAELs) or lowest-observed-adverse-effect levels (LOAELs) reflect the actual doses (levels of exposure) used in the studies. LOAELs have been classified into "less serious" or "serious" effects. "Serious" effects are those that evoke failure in a biological system and can lead to morbidity or mortality (e.g., acute respiratory distress or death). "Less serious" effects are those that are not expected to cause significant dysfunction or death, or those whose significance to the organism is not entirely clear. ATSDR acknowledges that a considerable amount of judgment may be required in establishing whether an end point should be classified as a NOAEL, "less serious" LOAEL, or "serious" LOAEL, and that in some cases, there will be insufficient data to decide whether the effect is indicative of significant dysfunction. However, the Agency has established guidelines and policies that are used to classify these end points. ATSDR believes that there is sufficient merit in this approach to warrant an attempt at distinguishing between "less serious" and "serious" effects. The distinction between "less serious" effects and "serious" effects is considered to be important because it helps the users of the profiles to identify levels of exposure at which major health effects start to appear. LOAELs or NOAELs should also help in determining whether or not the effects vary with dose and/or duration, and place into perspective the possible significance of these effects to human health.

3. HEALTH EFFECTS

The significance of the exposure levels shown in the Levels of Significant Exposure (LSE) tables and figures may differ depending on the user's perspective. Public health officials and others concerned with appropriate actions to take at hazardous waste sites may want information on levels of exposure associated with more subtle effects in humans or animals (LOAELs) or exposure levels below which no adverse effects (NOAELs) have been observed. Estimates of levels posing minimal risk to humans (Minimal Risk Levels or MRLs) may be of interest to health professionals and citizens alike.

Levels of exposure associated with carcinogenic effects (Cancer Effect Levels, CELs) of iodine are indicated in Tables 3-1 and 3-2 and Figures 3-1 and 3-2.

Estimates of exposure levels posing minimal risk to humans (Minimal Risk Levels or MRLs) have been made for iodine. An MRL is defined as an estimate of daily human exposure to a substance that is likely to be without an appreciable risk of adverse effects (noncarcinogenic) over a specified duration of exposure. MRLs are derived when reliable and sufficient data exist to identify the target organ(s) of effect or the most sensitive health effect(s) for a specific duration within a given route of exposure. MRLs are based on noncancerous health effects only and do not consider carcinogenic effects. MRLs can be derived for acute, intermediate, and chronic duration exposures for inhalation and oral routes. Appropriate methodology does not exist to develop MRLs for dermal exposure.

Although methods have been established to derive these levels (Barnes and Dourson 1988; EPA 1990), uncertainties are associated with these techniques. Furthermore, ATSDR acknowledges additional uncertainties inherent in the application of the procedures to derive less than lifetime MRLs. As an example, acute inhalation MRLs may not be protective for health effects that are delayed in development or are acquired following repeated acute insults, such as hypersensitivity reactions, asthma, or chronic bronchitis. As these kinds of health effects data become available and methods to assess levels of significant human exposure improve, these MRLs will be revised.

A User's Guide has been provided at the end of this profile (see Appendix B). This guide should aid in the interpretation of the tables and figures for Levels of Significant Exposure and the MRLs.

3.2.1 Inhalation Exposure

No studies were located on the toxicity of inhaled nonradioactive iodine. Iodine is absorbed in humans when I₂ or methyl iodide vapors are inhaled (Black and Hounam 1968; Morgan and Morgan 1967; Morgan et al. 1967a, 1967b, 1968). Once absorbed, iodide would be expected to exert effects that are similar to that of iodide absorbed after ingestion, including effects on the thyroid gland and thyroid hormone status, sensitivity reactions, and cancer (see Section 3.2.2). Iodine (I₂) is a strong oxidizing

3. HEALTH EFFECTS

agent; therefore, exposure to high air concentrations of I₂ vapor could potentially produce upper respiratory tract irritation and possibly oxidative injury.

A large amount of epidemiological literature exists on the health outcomes in populations exposed to radioiodine as a result of releases from explosions of nuclear bombs (e.g., Marshall Islands, Nevada Test Site), operational releases from nuclear fuel reprocessing facilities (e.g., Hanford Nuclear Site), and accidental releases from nuclear power plants (e.g., Chernobyl). Releases of these types resulted in mixed exposures to a variety of radioisotopes, and radiation doses from both external and internal exposure. However, doses from radioiodine that are significant to health effects derive largely from internal exposure to the thyroid gland as a result of absorption and uptake of radioiodine into the thyroid gland (see Section 3.4.2.2). Inhalation of airborne radioiodine is likely to have occurred after each of these releases and prior to ground deposition of radioiodine. However, the major contributors to thyroid radiation dose in each of these incidents are thought to have been from ingestion of milk, vegetation, and water contaminated from atmospheric deposition of radioiodine. Ingestion of human breast milk is also considered to have been a major contributor to doses received in nursing infants. For example, it has been estimated that, in seven Ukraine cities following releases of radioiodine from the Chernobyl nuclear power plant, inhalation of ¹³¹I contributed between 2 and 13% of total absorbed radiation dose, whereas the ingestion pathway contributed from 98 to 87% (IAEA 1991). In the Marshall Islands, after the BRAVO bomb test, the inhalation pathway is thought to have contributed <1% of the absorbed radioiodine, with the ingestion pathway contributing 80–99%; dermal absorption of radioiodine may have contributed as much as 20% (Lessard et al. 1985). Because of the more substantial contribution of the oral pathway to the absorbed thyroid radiation doses, health effects studies related to the Chernobyl accident, the Marshall Islands, the Hanford Nuclear Site, and the Nevada Test Site are discussed in the oral section of this profile (Section 3.2.2). However, the effects observed that have been related to the internal radiation dose to the thyroid gland are also directly relevant to inhalation exposures since inhaled radioiodine absorbed from either the respiratory tract or gastrointestinal tract would be expected to distribute to the thyroid gland (see Section 3.4.2.1, Toxicokinetics).

3.2.1.1 Death

Deaths related to thyroid cancers (or to other cancers or causes) following the Chernobyl accident are being studied with well-controlled epidemiological designs, and possible associations between mortality and radioiodine exposures may become evident once the dose reconstruction project, now underway, has been completed. Although radiation-related deaths were recorded among emergency response personnel on site during the Chernobyl accident, these deaths were associated with external exposure to gamma radiation from molten fuel areas and not with exposure to radioiodine.

3. HEALTH EFFECTS

3.2.1.2 Systemic Effects

All of the information on systemic effects of inhaled iodine in humans relates to endocrine effects from exposures to radioiodine following the BRAVO nuclear bomb test in the Marshall Islands, the Chernobyl accident, and radioiodine releases from the Hanford Nuclear Site. Because oral ingestion of radioiodine is thought to have been the major contributor to exposure, these studies are discussed in detail in Section 3.2.2. No information was located regarding respiratory, cardiovascular, gastrointestinal, hematological, musculoskeletal, hepatic, renal, dermal, ocular, body weight, or other systemic effects of inhalation exposure to iodine or radioiodine. However, one epidemiological study has examined health outcomes of infants of mothers who resided in the Belarus region before or after the Chernobyl accident (Petrova et al. 1997). The health outcomes observed in this study include respiratory, hematological, renal, and dermal effects; however, their association to radioiodine exposure has not been established. This study is discussed in greater detail in the sections of reproductive and developmental effects associated with oral exposures to radioiodine (Sections 3.3.1.5 and 3.3.1.6).

3.2.1.3 Immunological and Lymphoreticular Effects

All of the information on immunological effects of inhaled iodine in humans relates to thyroid gland autoimmunity and exposures to radioiodine following the BRAVO nuclear bomb test in the Marshall Islands, the Chernobyl accident, and releases of radioiodine from the Hanford Nuclear Site. Because exposures in these incidents are thought to have been largely from oral ingestion of radioiodine, these studies are discussed in detail in Section 3.2.2.

3.2.1.4 Neurological Effects

No information was located on neurological effects of inhaled iodine. Exposure to radioiodine at sufficient doses to produce hypothyroidism could give rise to neurological manifestations of thyroid gland dysfunction including impairments in neurological development and myopathy (Boyages 2000a, 2000b). Congenital hypothyroidism can be associated with a severe impairment in neurological development of the fetus termed *cretinism*, which usually occurs in areas of endemic iodine deficiency. This condition would be highly unlikely in iodine-induced hypothyroidism secondary to inhalation of iodine.

3. HEALTH EFFECTS

3.2.1.5 Reproductive Effects

No information was located regarding reproductive effects of inhalation exposure to iodine or radioiodine. However, a large-scale retrospective analysis was conducted to evaluate pregnancy health and reproductive outcomes of women who were exposed to radiation resulting from releases from the Chernobyl nuclear power plant, including a major contribution from ^{131}I (Petrova et al. 1997). Although inhalation of radioiodine certainly occurred in this population, internal radiation doses resulting from this incident are thought to have been largely from oral ingestion of radioiodine (IAEA 1991). The study is summarized in greater detail in Section 3.3.1.5, which discusses the reproductive effects of oral exposures to radioiodine.

3.2.1.6 Developmental Effects

No information was located regarding developmental effects associated with inhalation exposure to iodine or radioiodine other than those related to the thyroid gland (e.g., Marshall Islands, Section 3.3.1.1, Endocrine Effects). However, one epidemiological study has examined health outcomes of infants of mothers who resided in the Belarus region before or after the Chernobyl accident (Petrova et al. 1997). Exposures resulting from this incident are thought to have been largely from oral ingestion of radioiodine (IAEA 1991) and, therefore, a summary of this study can be found in Section 3.3.1.6 on the developmental effects of oral exposures to radioiodine.

3.2.1.7 Cancer

No information was located on carcinogenicity of inhaled stable iodine. Thyroid cancers have been associated with exposures to radioiodine following the BRAVO nuclear bomb test in the Marshall Islands and the Chernobyl accident. Thyroid cancers have also been studied in populations exposed to radioiodine released from nuclear bomb tests at the Nevada Test Site, and from operational releases of radioiodine from the Hanford Nuclear Site. Although the inhalation of radioiodine occurred in these incidents, oral ingestion of radioiodine is thought to have been the major contributor to thyroid radiation doses. Summaries of these studies can be found in Section 3.3.1.7 on cancer effects of oral exposures to radioiodine.

3.2.2 Oral Exposure

The section that follows provides background information relevant to the various study summaries that are presented subsequently. A description of the approaches used to calculate doses of stable iodine is provided. Also provided is background information on the exposure scenarios from the major

3. HEALTH EFFECTS

radioiodine-releasing events for which health effects studies have been reported. The actual study summaries follow. For each category of health effect, studies of oral exposures to stable iodine are presented first, followed by summaries of studies of radioiodine exposures.

Stable Iodine. A large number of human experimental, clinical, and epidemiological studies on the effects of excess iodine on human health have been reported. The key studies that provide information on exposures associated with effects are summarized in this section of the profile. Oral iodine intakes were not directly assessed in many studies with sufficient accuracy to define dose-response relationships; however, measurements of urinary iodide provide a basis for estimating intakes in some of the studies (Konno et al. 1993b). Rather than describing the basis for estimating intakes from urinary iodine data in each of the study descriptions that follow, the general approach used is described here. If a 24-hour urinary iodide measurement was provided that could be regarded as a steady state value (relatively constant intake for at least 6 months), the intake was assumed to be equivalent to the 24-hour excretion rate. This assumption is consistent with information available on the toxicokinetics of iodide that indicates nearly complete absorption of ingested iodide and that urinary excretion accounts for >97% of the absorbed dose (see Sections 3.4.1.2 and 3.4.4.2). The assumption is also supported by studies in which 24-hour urinary iodide was measured before and after supplementation. For example, 31 patients received oral supplements of 382 µg I/day for 6 months. Prior to the supplementation, the mean 24-hour urinary iodide excretion rate was 36 µg/day (range, 13–69), whereas after 6 months of iodide supplementation, the mean 24-hour urinary iodide excretion rate was 415 µg/day (Kahaly et al. 1998). The difference between these two values, 379 µg/day, is nearly identical to the supplemental dose of 382 µg/day.

If a urine iodide concentration was provided for a morning sample that included overnight bladder urine, the measured concentration was assumed to represent the 24-hour average concentration and iodide intake was calculated as:

$$Intake_I = U_I \cdot 1.4 \quad \text{Equation (1)}$$

where U_I is the measured urinary iodine concentration and 1.4 is the average urine volume (L/day) for a 70-kg adult (ICRP 1981). Equation 1 is in reasonable agreement with observed relationships between morning bladder urine iodide concentrations and 24-hour iodide excretion rates (Konno et al. 1993b; Nagata et al. 1998). Urine iodide concentration from untimed (spot) samples, other than morning samples that included overnight bladder urine, were considered too uncertain to derive intake estimates, unless paired urinary creatinine concentrations or a urinary iodide:creatinine ratio (µg I:g creatinine) was reported. Urinary iodide:creatinine ratios were converted to estimated iodide intake as follows, assuming a constant relationship between urinary creatinine excretion rate and lean body mass. The rate of

3. HEALTH EFFECTS

creatinine excretion (e.g., E_{Cr} , g creatinine/day) was calculated from the relationship between lean body mass (LBM) and E_{Cr} :

$$LBM = 0.0272 \cdot E_{Cr} + 8.58 \quad \text{Equation (2)}$$

where the constants 0.0272 and 8.58 are the weighted arithmetic mean of estimates of these variables from eight studies reported in Forbes and Bruining (1976). Lean body mass was calculated as follows (ICRP 1981):

$$LBM = BW \cdot 0.88, \text{ males} \quad \text{Equation (3)}$$

$$LBM = BW \cdot 0.85, \text{ females}$$

where BW is the reported or assumed body weight for males (75 kg) and females (65 kg) (EPA 1997f). A mean value of 60 kg (females, 55 kg; males, 65 kg) was assumed for body weights of adult populations of the Asian Pacific countries (e.g., Japan, China, Marshall Islands). Iodide intake was calculated as:

$$Intake_I = U_{I/Cr} \cdot E_{Cr} \quad \text{Equation (4)}$$

where $U_{I/Cr}$ is the urinary iodide:creatinine ratio ($\mu\text{g I/g creatinine}$). This approach yields relationships between 24-hour urinary iodide excretion rates and the urinary iodide:creatinine ratios that are in reasonable agreement with observations (Konno et al. 1993b).

Radioactive Iodine. A discussion of the relevant biokinetics of radioiodine is provided in Sections 3.4.

Marshall Islands BRAVO Test. Several epidemiological studies have examined thyroid gland disorders in residents of the Marshall Islands who were exposed to radioiodine from atmospheric fallout after an atmospheric nuclear bomb test (the so-called *BRAVO* test). Residents of islands near and downwind from the test site on Bikini Atoll (e.g., Ailingnae, Rongelap, Utirik) were exposed to both internal radionuclides and external gamma radiation from fallout during the 2 days prior to their evacuation. The estimated cumulative gamma radiation dose on these islands ranged from 69 to 175 rad (0.7–1.75 Gy) or approximately 10–50% of the estimated thyroid dose (Conard 1984). Later estimates suggest that external radiation contributed approximately 4–16% of total thyroid dose (Hamilton et al. 1987). Internal exposures, resulting primarily from radioiodine, were much higher. Although inhalation of airborne radioiodine probably occurred during the fallout period immediately after the blast, ingestion of deposited radioiodine on locally harvested foods and surface water during the subsequent 2 days prior to evacuation

3. HEALTH EFFECTS

is thought to be the major contributor to the internal exposures (Lessard et al. 1985). Nursing infants would also have received internal exposures from ingestion of radioiodine in breast milk. Estimated total absorbed doses to the thyroid gland (external and internal) were 3.3–20 Gy (330–2,000 rad) on Rongelap (highest doses in children), 1.3–4.5 Gy (130–450 rad) on Ailingnae, and 0.3–0.95 Gy (30–95 rad) on Utirik (Conard 1984). Estimates of the internal radiation dose to the thyroid remain uncertain as they were based primarily on measurements of radioiodine (principally ^{131}I) in a pooled urine sample, collected 15 days after exposure, from a subset of exposed people. Although these measurements allowed back extrapolation of the initial internal ^{131}I exposures, shorter-lived radioiodine species (^{132}I , ^{133}I , ^{135}I) could not be detected in the urine sample. These isotopes are thought to have contributed 2–3 times the thyroid radiation dose of ^{131}I (Conard 1984). It is generally agreed that external radiation exposures resulted nearly entirely from fallout and deposits of radionuclide-containing materials on the skin, rather than from direct photon irradiation from the blast, as the exposed populations were approximately 100–320 miles from the detonation site. In this respect, the Marshall Island exposures are very different from the Hiroshima and Nagasaki exposures, which are characterized by acute (single dose) exposure to mostly gamma radiation (with a small neutron contribution in Hiroshima). Numerous bomb tests were conducted in the Marshall Islands during the period 1946–1958. Comparisons of ^{137}Cs in soils in the Marshall Islands with estimates of global fallout in the mid-Pacific region suggest contamination from local activities over much of the Marshall Islands (i.e., local ^{137}Cs :global ^{137}Cs ratio > 1) with particularly high local:global ^{137}Cs ratios (>10) on the islands of Bikini (test site), Enewatak (test site), Rongelap, and Utirik (Takahashi et al. 1997).

Chernobyl Accident. In 1986, a chemical explosion and fire at the nuclear power plant in Chernobyl in the Ukraine was caused by the uncontrolled release of stored energy in graphite moderator blocks; this resulted in the release of airborne radionuclides to the surrounding regions and contamination of soil and locally grown foods. The external radiation exposures were contributed largely by isotopes of cesium (e.g., ^{137}Cs), which accounted for approximately 90–98% of the external radiation dose (Mould 2000; UNSCEAR 2000; Vargo 2000). Radioiodine is estimated to have contributed approximately 50% of the internal committed radiation dose for children born in 1986 in the region and approximately 80% of the total radiation dose received during the first year after the release (Vargo 2000). Estimates of thyroid radiation doses have been derived from external thyroid gland scans that measure radiation (most gamma) from radioiodine in the thyroid. These measurements suggest that radioiodine doses to the thyroid gland were highest in children <1 year of age at the time of the release, and were highest in locations nearest to the nuclear plant where contaminated food was not quarantined. The highest estimated doses were received within 30 km of the Chernobyl plant; median doses ranged from 2.3 Gy (250 rad) at age <1 year to 0.4 Gy (40 rad) in adolescents and adults (UNSCEAR 2000). Estimated median doses received in populations residing 100–200 km from the plant (e.g., Mogilev region) were <0.3 Gy (30 rad) for all age groups (UNSCEAR 2000). Although inhalation of airborne radioiodine is likely to have occurred after

3. HEALTH EFFECTS

the accident, the major contributors to the absorbed thyroid radiation dose are thought to have been from ingestion of milk, vegetation, and water contaminated from atmospheric deposition of radioiodine. Ingestion of human breast milk is also considered to have been a major contributor to doses received *in utero* and in nursing infants. For example, it has been estimated that, in seven Ukraine cities, ingestion of ^{131}I contributed between 87 and 98% of total absorbed radiation dose (IAEA 1991). Estimated doses in Finland were significantly lower than on comparably contaminated areas in Belarus because of the control exercises to quarantine contaminated food until radioiodine levels had sufficiently decayed. Endemic goiter in the Belarus population (Gembicki et al. 1997) and differences in the extent of use of stable iodine to mitigate the thyroid dose may have also contributed to the differences in the thyroid doses observed in Belarus compared to similarly contaminated areas of Finland.

Thyroid dose estimates, particularly peak dose rates, are largely based on extrapolations from thyroid gland ^{131}I measurements made within 1 to several weeks after the major release from the Chernobyl plant and ground monitoring of atmospheric deposition of radioiodine. One set of measurements of thyroid gland radioactivity came from postmortem measurements of thyroid glands from 416 people collected over the period from May 3 (8 days after the initial release) to August 4, 1986 (Beno et al. 1991). Back extrapolation of thyroid gland activities and consideration of temporal trends in both the thyroid gland data and atmospheric deposition allowed the estimation of transfer coefficients relating atmospheric deposition of radioiodine (kBq/m^2) and thyroid dose (μSv); the coefficients were $641 \mu\text{Sv}/\text{kBq}\cdot\text{m}^2$ in exposed children and $221 \mu\text{Sv}/\text{kBq}\cdot\text{m}^2$ in exposed adults (Beno et al. 1992). Based on this approach, thyroid radiation doses may have ranged from 0.12 to 24 Sv (12–2,400 rem) in children and from 0.04 to 8 Sv (4–800 rem) in adults. In Gomel, where the highest incidence of thyroid cancer in children has been reported, the transfer coefficients yield estimated doses of 1.2–12.3 Sv (120–1,230 rem) in children (Bleuer et al. 1997; Drobysheskaya et al. 1996). Various other approaches have been used to estimate thyroid doses associated with the Chernobyl. In the Ukraine, most of these rely on exposure estimates based on measured ratios of long-lived isotopes of iodine (e.g., ^{129}I) and assumed relationships between radioiodine and ^{137}Cs air levels and/or deposition, and models of indirect pathways, including milk ingestion (Ilyin et al. 1990; Likhtarev et al. 1995). Estimates of absorbed thyroid doses from ^{131}I based on ^{137}Cs deposition densities in seven Ukraine cities ranged from 80 to 240 cGy (rad) in infants, 64–190 cGy (rad) in children, and 19–57 cGy (rad) in adults (IAEA 1991). In estimates of lifetime radiation doses, almost all of the radiation exposure was received in the first 3 months after the accident, during which time, the ^{131}I activity decreased to $<0.1\%$ of the initial values. The continued ^{129}I exposure can be considered minimal, although it will persist for several decades for some populations because of environmental contamination and its longer decay half-life.

Nevada Test Site. During the period 1951–1958, 119 atmospheric nuclear bomb tests were conducted at the Nevada Test Site (NTS) in southern Nevada (NCI 1997). These tests were followed by nine surface

3. HEALTH EFFECTS

detonations during the period 1962–1968 and approximately 809 below-ground tests, of which 38 were determined to have resulted in off-site releases of radioactive materials. A dose estimation methodology was developed by the National Cancer Institute (NCI 1997), which has enabled estimates of population radiation doses to the thyroid gland from direct and indirect (e.g., ingestion of cow milk) exposures to ^{131}I resulting from the NTS activities for the purpose of health assessments and epidemiologic investigations (Gilbert et al. 1998; Kerber et al. 1993). Geographic-specific geometric mean lifetime doses are estimated to have ranged from 0.19 to 43 cGy (rad) for people born on January 1, 1952 who consumed milk only from commercial retail sources, 0.7–55 cGy (rad) for people who consumed milk only from home-reared cows, and 6.4–330 cGy (rad) for people who consumed milk only from home-reared goats (NCI 1997; NRC 1999). A discussion of the uncertainties and limitations of these population dose estimates for use in epidemiology studies and risk assessment can be found in a review of the NCI (1997) dose estimations conducted by the Institute of Medicine and the National Research Council (NRC 1999).

Hanford Nuclear Site. The Hanford Nuclear Site in southeastern Washington reprocessed uranium to produce plutonium. Radioiodine was released to the atmosphere during the early years of operation of the facility. Approximately 740,000 Ci (27 PBq) of ^{131}I was estimated to have been released to the atmosphere during the period 1944–1957 (CDC 1999; at the time this profile was developed, a draft report of this study was available from the Fred Hutchinson Cancer Research Center web site (<http://www.fhcrc.org/science/phs/htds/>); however, a final published report was not available). Thyroid radiation doses have been estimated using a dosimetry model developed in the Hanford Environmental Dose Reconstruction Project. The estimated mean thyroid radiation dose in a population of 3,190 people who resided near the facility was 182 mGy (± 227 , standard deviation [SD]) (18.2 \pm 22.7 rad), and the range was 0.0008–2,842 mGy (0.00008–284 rad). Doses varied geographically, with the highest doses received by people who lived near and downwind from the site.

3.2.2.1 Death

Two recent reviews of the clinical case literature note that deaths have occurred after ingestion of iodine preparations (FDA 1989b, 1990b). A review of medical records from the New York City Medical Examiners Office revealed that, in a period of 6 years, there were 18 deaths from attempted suicides in which adults ingested iodine tinctures (Finkelstein and Jacobi 1937). Tinctures of iodine contain a mixture of molecular iodine (I_2) and sodium triiodide (NaI_3) and have iodine concentrations of approximately 40 mg/mL. Doses of iodine from ingestion of the tinctures ranged from 1,200 to 9,500 mg (17–120 mg/kg), and deaths usually occurred within 48 hours of the dose. In one case, an adult male ingested 15 g of iodine as a potassium iodide solution and survived the episode; 18 hours after the dose, his serum iodide concentration was 2.95 mg/mL (Tresch et al. 1974). Symptoms of toxicity that have been observed in lethal or near-lethal poisonings have included abdominal cramps, bloody diarrhea and

3. HEALTH EFFECTS

gastrointestinal ulceration, edema of the face and neck, pneumonitis, hemolytic anemia, metabolic acidosis, fatty degeneration of the liver, and renal failure (Clark 1981; Dyck et al. 1979; Finkelstein and Jacobi 1937; Tresch et al. 1974).

Two cases of infant deaths were reported in which death was from complications related to compression of the trachea by a goiterous thyroid gland; the mothers had ingested potassium iodide during their pregnancies at doses of approximately 850 and 1,180 mg I/day (12 and 17 mg/kg/day) (Galina et al. 1962).

Although radiation-related deaths were recorded among emergency response personnel on site during the Chernobyl accident, these deaths were associated with exposure to gamma radiation from molten fuel areas and not with exposure to radioiodine. External, but not internal exposure to radiation from a variety of radionuclides caused these deaths. Approximately 134 cases of acute radiation sickness (ARS) were recorded, mainly in plant workers and firemen, of which 120 deaths were later attributed to radiation. Symptoms included skin burns, epithelial injuries, and bone marrow suppression, which are typical of ARS. Thyroid disorders, which would have been indicative of radioiodine toxicity, were not reported and would have been inconsequential had they occurred in context with the extreme health consequences associated with ARS. Deaths related to thyroid cancers (or to other cancers or causes) following the accident are being studied with well controlled epidemiological designs, and possible associations between mortality and radioiodine exposures may become evident once the dose reconstruction project, now underway, has been completed.

The LOAEL values in humans for exposures by the oral route are presented in Table 3-1 and plotted in Figure 3-1.

3.2.2.2 Systemic Effects

Systemic effects of oral iodine exposure, other than after massive acute iodine overload such as in cases of attempted suicides (see Section 3.2.2.1), are on the thyroid gland and are discussed in the section on Endocrine Effects. As noted in the introduction to this chapter of the profile, adverse effects on a wide variety of other organ systems can result from iodine-induced disorders of the thyroid gland, including disturbances of the skin, cardiovascular system, pulmonary system, kidneys, gastrointestinal tract, liver, blood, neuromuscular system, central nervous system, skeleton, male and female reproductive systems, and numerous endocrine organs, including the pituitary and adrenal glands. The reader is referred to authoritative references on these subjects for further information (Braverman and Utiger 2000).

Table 3-1. Levels of Significant Exposure to Iodine - Chemical Toxicity - Oral

Key to figure ^a	Species (Strain)	Exposure/ duration/ frequency (Specific route)	System	NOAEL (mg/kg/day)	LOAEL		Reference Chemical Form
					Less serious (mg/kg/day)	Serious (mg/kg/day)	
ACUTE EXPOSURE							
Death							
1	Human	1 d				17 (death)	Finkelstein and Jacobi 1937 I ₂ , NaI ₃
Systemic							
2	Human	14 d (C)	Endocr	0.0086	(subclinical hypothyroidism without autoimmunity)		Chow et al. 1991 KI
3	Human	1 d (C)	Endocr	3.4			Delange 1996 Iodized oil
4	Human	14 d (C)	Endocr	0.069	(subclinical hypothyroidism without autoimmunity)		Gardner et al. 1988 NaI
5	Human	7 d (W)	Endocr	0.46	(subclinical hypothyroidism)		Georgitis et al. 1993 I ₂ , I ⁻
6	Human	14 d (C)	Endocr	0.024 ^b	(subclinical hypothyroidism)		Paul et al. 1988 NaI
7	Human	14 d (C)	Endocr	1.0	(subclinical hypothyroidism)		Robison et al. 1998 NaI
8	Human	14 d (C)	Endocr	1.0	(subclinical hypothyroidism)		Robison et al. 1998 I ₂

3. HEALTH EFFECTS

DRAFT FOR PUBLIC COMMENT

Table 3-1. Levels of Significant Exposure to Iodine - Chemical Toxicity- Oral (continued)

Key to figure ^a	Species (Strain)	Exposure/ duration/ frequency (Specific route)	System	NOAEL (mg/kg/day)	LOAEL		Reference Chemical Form
					Less serious (mg/kg/day)	Serious (mg/kg/day)	
Immunological/Lymphoreticular							
9	Human	8 d (C)				20 (fever)	Horn and Kabins 1972 KI
10	Human	5 d (C)				4.3 (ioderma)	Soria et al. 1990 KI

Table 3-1. Levels of Significant Exposure to Iodine - Chemical Toxicity- Oral (continued)

Key to ^a figure	Species (Strain)	Exposure/ duration/ frequency (Specific route)	System	NOAEL (mg/kg/day)	LOAEL		Reference Chemical Form	
					Less serious (mg/kg/day)	Serious (mg/kg/day)		
INTERMEDIATE EXPOSURE								
Death								
11	Human	9 mo (C)				12	(death from tracheal compression by goiter)	Galina et al. 1962 KI
12	Human	9 mo (C)				17	(death from tracheal compression by goiter)	Galina et al. 1962 KI
Systemic								
13	Human	4 mo (C)	Endocr			23	(clinical hyperthyroidism with thyrotoxicosis)	Ahmed et al. 1974 KI
14	Human	2 mo (C)	Endocr			7.3	(goiter in neonate)	Coakley et al. 1989 KI
15	Human	9 mo (C)	Endocr			6.4	(goiter and hypothyroidism in neonate)	Hassan et al. 1968 KI
16	Human	11 wk (W)	Endocr	15			(subclinical hypothyroidism)	Jubiz et al. 1977 KI
17	Human	90 d (C)	Endocr	0.0039	0.46		(subclinical hypothyroidism with gland enlargement)	LeMar et al. 1995 I ₂ , I-
18	Human	9 mo (C)	Endocr	0.0047				Liesenkotter et al. 1996 KI

3. HEALTH EFFECTS

DRAFT FOR PUBLIC COMMENT

Table 3-1. Levels of Significant Exposure to Iodine - Chemical Toxicity- Oral (continued)

Key to figure ^a	Species (Strain)	Exposure/duration/frequency (Specific route)	System	NOAEL (mg/kg/day)	LOAEL		Reference Chemical Form
					Less serious (mg/kg/day)	Serious (mg/kg/day)	
19	Human	9 mo (C)	Endocr			13 (goiter, hypothyroidism in neonate)	Martin and Rento 1992 KI
20	Human	28 d (C)	Endocr		0.39 (subclinical hypothyroidism with gland enlargement)		Namba et al. 1993 I-
21	Human	3 mo (C)	Endocr			5.4 (goiter in neonate)	Penfold et al. 1978 KI
22	Human	4 mo (C)	Endocr			6.6 (goiter in neonate)	Penfold et al. 1978 KI
23	Human	6 mo (C)	Endocr			0.05 (clinical hypothyroidism)	Shilo and Hirsch 1986 sea-kelp
24	Human	7 wk (C)	Endocr			2.6 (clinical hyperthyroidism with thyrotoxicosis)	Vagenakis et al. 1972 KI
25	Human	9 mo (C)	Endocr			4.6 (goiter in fetus)	Vicens-Colvet et al. 1998 ND
Immunological/Lymphoreticular							
26	Human	NS (C)				23 (fever)	Horn and Kabins 1972 KI
27	Human	6 mo (C)				11 (ioderma)	Kincaid et al. 1981 KI

3. HEALTH EFFECTS

Table 3-1. Levels of Significant Exposure to Iodine - Chemical Toxicity - Oral (continued)

Key to figure ^a	Species (Strain)	Exposure/ duration/ frequency (Specific route)	System	NOAEL (mg/kg/day)	LOAEL		Reference Chemical Form
					Less serious (mg/kg/day)	Serious (mg/kg/day)	
28	Human	8 mo (C)				8.6 (ioderma)	Soria et al. 1990 KI

Table 3-1. Levels of Significant Exposure to Iodine - Chemical Toxicity- Oral (continued)

Key to ^a figure	Species (Strain)	Exposure/ duration/ frequency (Specific route)	System	NOAEL (mg/kg/day)	LOAEL		Reference Chemical Form
					Less serious (mg/kg/day)	Serious (mg/kg/day)	
CHRONIC EXPOSURE							
Systemic							
29	Human	11 yr (W)	Endocr	0.010 ^c	0.029	(subclinical hypothyroidism with gland enlargement)	Boyages et al. 1989 I-
30	Human	2 yr (C)	Endocr				2.9 (clinical hypothyroidism with goiter in neonate) Iancu et al. 1974 NaI
31	Human	NS (W)	Endocr				1.0 (goiter with elevated serum TSH) Khan et al. 1998 ND
32	Human	46 yr (F)	Endocr				0.22 (clinical hypothyroidism without autoimmunity) Konno et al. 1994 I-
33	Human	68 yr (F, W)	Endocr	0.0046		(subclinical hypothyroidism; elderly adults)	Laurberg et al. 1998 I-
34	Human	16 mo (C)	Endocr	0.0039			Pedersen et al. 1993 KI
35	Human	81 yr (F, W)	Endocr	0.0023			0.0120 (clinical hypothyroidism without autoimmunity; elderly adults) Szablocs et al. 1997 I-
Immunological/Lymphoreticular							
36	Human	15 yr (C)					15 (fever) Kurtz and Aber 1982 KI

3. HEALTH EFFECTS

DRAFT FOR PUBLIC COMMENT

Table 3-1. Levels of Significant Exposure to Iodine - Chemical Toxicity - Oral (continued)

Key to figure ^a	Species (Strain)	Exposure/ duration/ frequency (Specific route)	System	NOAEL (mg/kg/day)	LOAEL		Reference Chemical Form
					Less serious (mg/kg/day)	Serious (mg/kg/day)	
37	Human	1 yr (C)				14 (ioderma)	Rosenberg et al. 1972 KI
Cancer							
38	Human	NS (F)				0.0035 (thyroid cancer; in endemic goiter area)	Bacher-Stier et al. 1997 I-
39	Human	NS (F)				0.0035 (thyroid cancer; in endemic goiter area)	Harach and Williams 1995 I-

^aThe number corresponds to entries in Figure 3-1.

^bUsed to derive an acute oral MRL of 0.01 mg/kg/day; dose divided by an uncertainty factor of 2 for human variability.

^cUsed to derive a chronic oral MRL of 0.005 mg/kg/day; dose divided by an uncertainty factor of 2 for human variability.

(C) = capsule; d = day(s); Endocr = endocrine; (F) = feed; kg = kilogram(s); LOAEL = lowest-observed-adverse-effect level; mg = milligram(s); mo = month(s); NOAEL = no-observed-adverse-effect level; NS = not specified; TSH = thyroid-stimulating hormone; (W) drinking water; wk = week(s); yr = year(s)

Figure 3-1. Levels of Significant Exposure to Iodine - Chemical Toxicity - Oral
Acute (≤ 14 days)

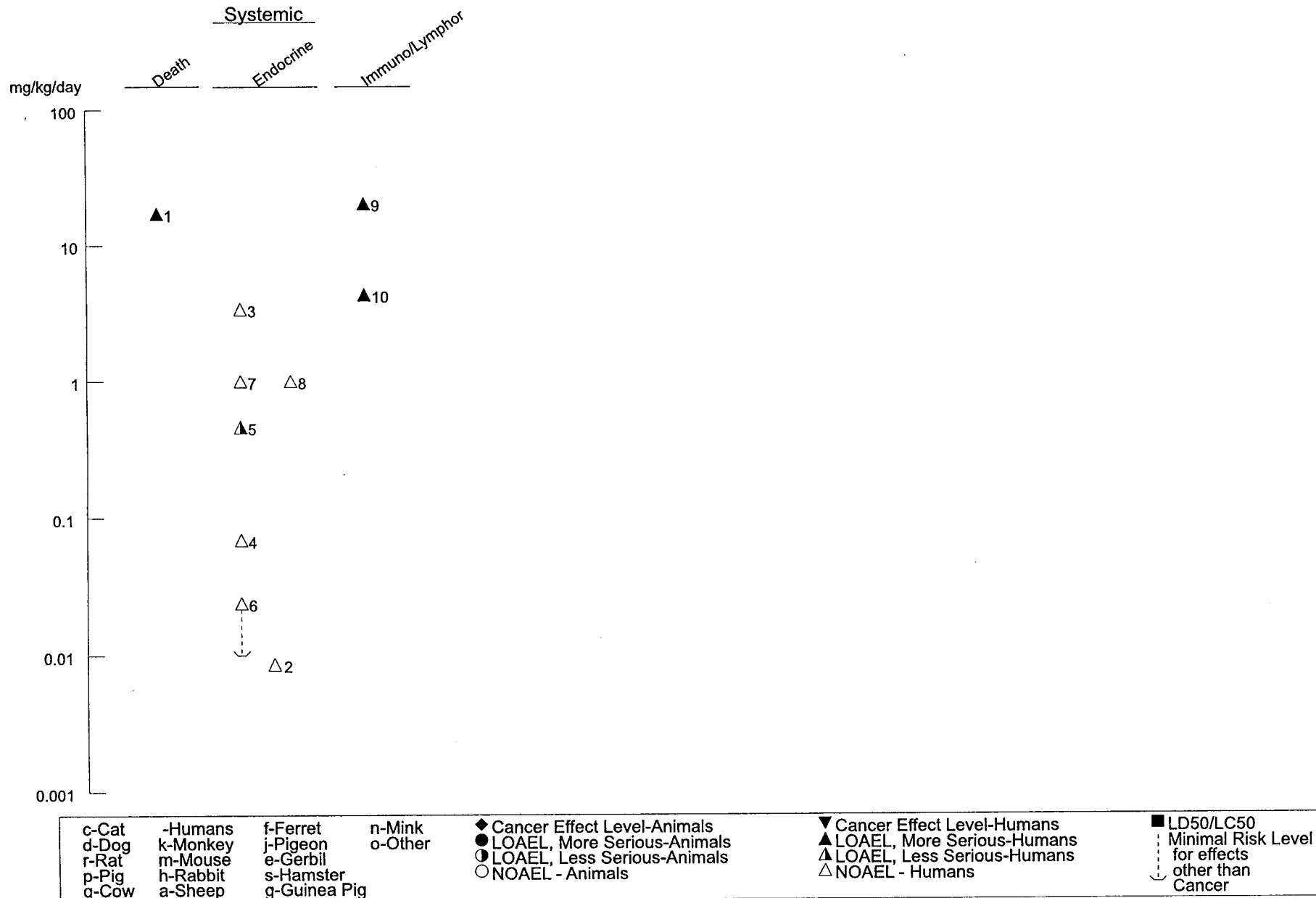

DRAFT FOR PUBLIC COMMENT

Figure 3-1. Levels of Significant Exposure to Iodine - Chemical Toxicity - Oral (continued)
Intermediate (15-364 days)

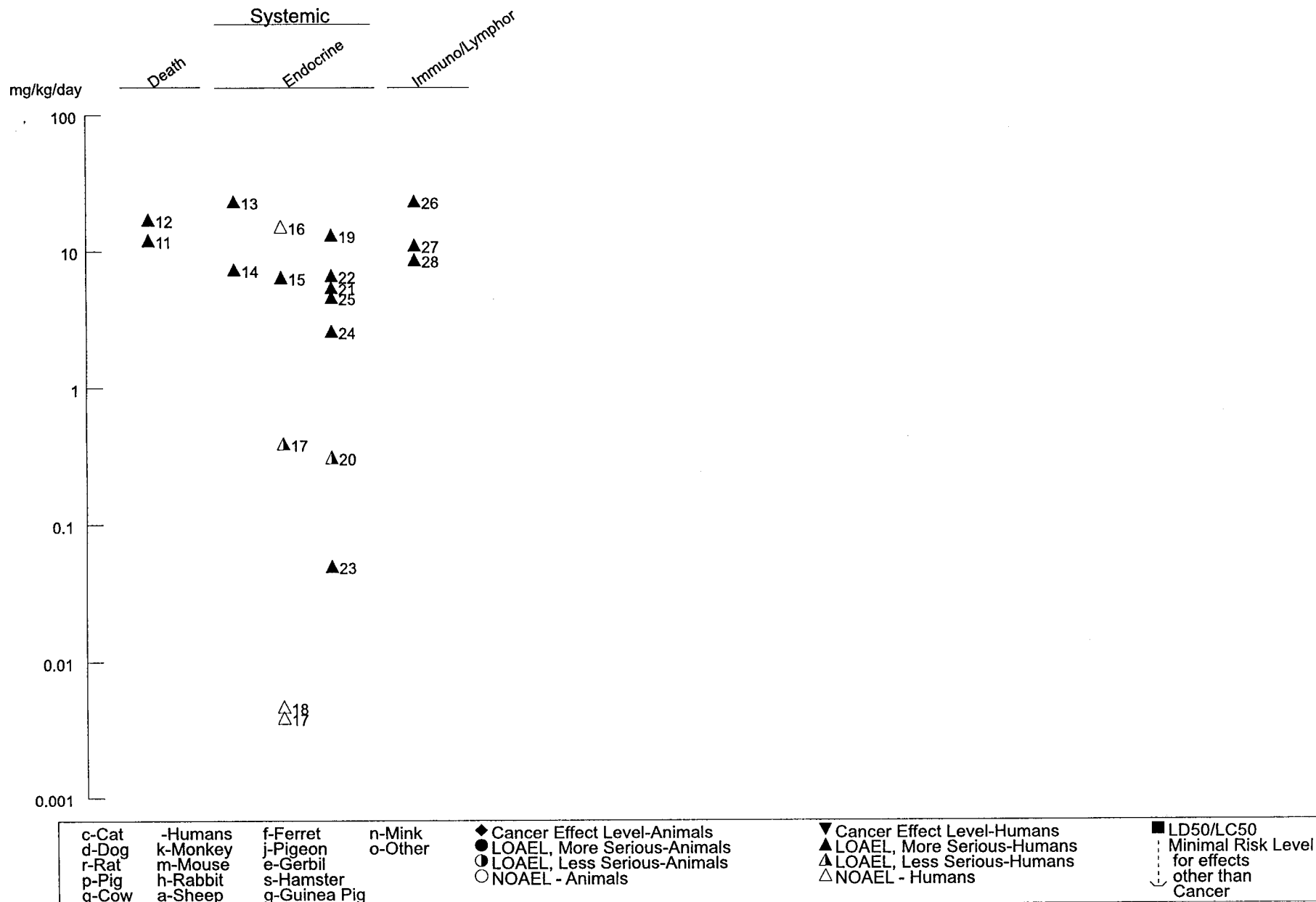

DRAFT FOR PUBLIC COMMENT

Figure 3-1. Levels of Significant Exposure to Iodine - Chemical Toxicity - Oral (continued)
Chronic (≥365 days)

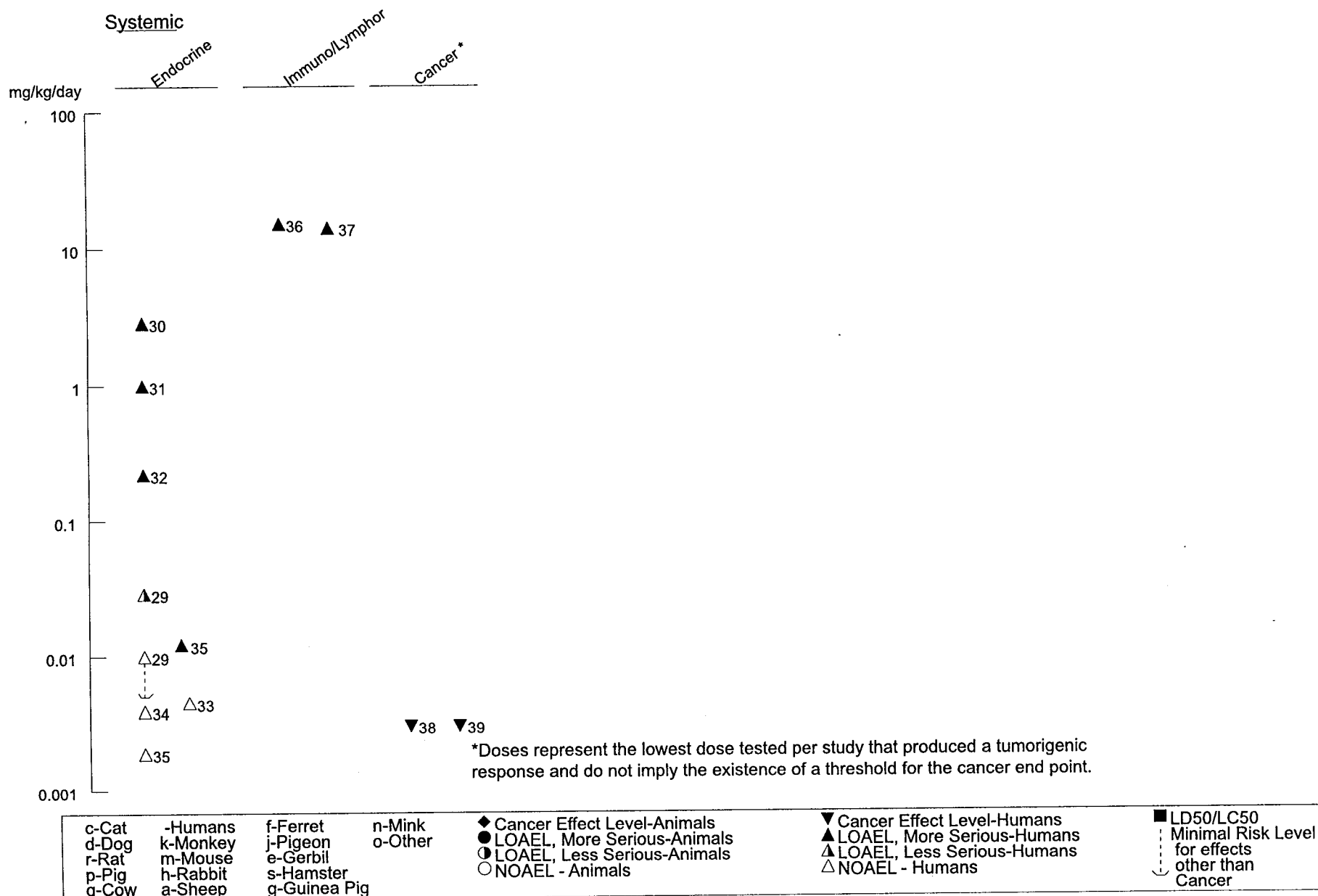

DRAFT FOR PUBLIC COMMENT

3. HEALTH EFFECTS

The major systemic effects of exposures to radioiodine are on the thyroid gland; however, other systemic effects have been observed, including inflammation of the salivary glands (sialadenitis), following relatively high exposures to radioiodine such as those used for ablative treatment of thyroid cancers.

The highest NOAEL values and all reliable LOAEL values in each duration category for systemic (endocrine) effects from exposures by the oral route are presented in Table 3-1 and plotted in Figure 3-1.

Gastrointestinal Effects. Ablative treatment of thyroid cancers with ^{131}I has been associated with inflammation of the salivary glands (sialadenitis) in humans (Allweiss et al. 1984; Bohuslavizki et al. 1996, 1998a and b, 1999; Mandel and Mandel 1999). Salivary glands express a transport protein, the sodium-iodine symport (NIS), which is also present in the thyroid gland where it functions to transport iodide into the gland for hormone synthesis. Salivary glands can accumulate iodide in saliva at concentrations considerably above that in serum (see Sections 3.4.2.2 and 3.5.1). The range of administered radioiodine in these cases was 100–300 mCi (3.7–11 GBq). Sialadenitis usually occurred within a few days or weeks of exposure and had a duration of several weeks to 2–3 years.

Endocrine Effects.

Endocrine Effects of Stable Iodine

The principal direct effects of excessive iodine ingestion on the endocrine system are on the thyroid gland and regulation of thyroid hormone production and secretion. Adverse effects on the pituitary and adrenal glands derive secondarily from disorders of the thyroid gland. Effects on the thyroid gland can be classified into three types: hypothyroidism, hyperthyroidism, and thyroiditis. Hypothyroidism refers to the diminished production of thyroid hormone leading to clinical manifestations of thyroid insufficiency and can occur with or without goiter, a functional hypertrophy of the gland in response to suppressed hormone production. Typical biomarkers of hypothyroidism are a depression in the circulating levels of thyroxine (T_4) and/or triiodothyronine (T_3) below their normal ranges. This is usually, but not always, accompanied by an elevation of thyroid stimulating hormone (TSH, also known as thyrotropin) above the normal range. Hyperthyroidism is an excessive production and/or secretion of thyroid hormones. The clinical manifestation of abnormally elevated circulating levels of T_4 and/or T_3 is thyrotoxicosis. Thyroiditis refers to an inflammation of the gland, which is often secondary to thyroid gland autoimmunity. The above three types of effects can occur in children and adults, in fetuses exposed *in utero*, or in infants during lactation.

Measurements of serum levels of thyroid hormones and TSH are often used as biomarkers of hypothyroidism and hyperthyroidism in toxicology and epidemiology studies. In interpreting this

3. HEALTH EFFECTS

literature in terms of human health risks, a distinction must be made between outcomes that have a high potential for producing clinical manifestations from those outcomes that are not clinically significant. In this profile, an observed decrease in circulating T₄ or T₃ levels or an increase in serum TSH level, within their respective normal ranges, is referred to as *subclinical hypothyroidism*. Similarly, the term *subclinical hyperthyroidism* refers to a condition in which the circulating levels of T₄ or T₃ are elevated within their normal ranges. Typical normal ranges for these hormone levels are discussed in Section 3.8.2

Hypothyroidism.

An acute iodide excess (above the preexisting dietary intake) decreases the production of thyroid hormones (organification of iodide) in the thyroid gland; this effect is referred to as the *Wolff-Chaikoff effect* (Wolff et al. 1949). In most people, this is followed by a return to normal levels of hormone synthesis, referred to as *escape* from the Wolff-Chaikoff effect, without a change in circulating hormone levels. Escape is thought to be the result of down regulation of the iodine transport mechanism in the thyroid gland (see Section 3.4.3.2 for further details on the Wolff-Chaikoff effect). An acute or chronic excess of iodide can also decrease circulating T₄ and T₃ levels and induce a hypothyroid state. These effects are thought to involve the inhibition of the release of T₄ from the thyroid gland and/or inhibition of extrathyroidal production of T₃. Most iodine-induced hypothyroidism is transient, although T₄ replacement may be required in some patients. Hypothyroidism is thought to occur primarily in *susceptible* individuals who fail to escape from the inhibitory effect of large doses of iodide that produce the Wolff-Chaikoff effect. Susceptible individuals include fetuses and newborn infants, patients who have autoimmune thyroiditis, patients with Graves' disease previously treated with iodine or antithyroid drugs, women who have had postpartum thyroiditis, or those who have had subacute thyroiditis. Spontaneous recovery usually occurs within 2–3 weeks, although some individuals may develop permanent thyroiditis (Markou et al. 2001).

Several studies have examined the acute effects of increased intakes of iodine on thyroid hormone status of adults (Chow et al. 1991; Gardner et al. 1988; Georgitis et al. 1993; Namba et al. 1993; Paul et al. 1988; Robison et al. 1998). The results of these studies suggest that acute (14 days) increases in iodine intake of 1,500 µg/day (21 µg/kg/day) above the preexisting dietary intake can be tolerated without producing a clinically adverse change in thyroid hormone levels, although such doses may produce a reversible depression in serum T₄ concentration and an elevation in serum TSH concentration, both within the normal range of values for healthy individuals. Changes in thyroid hormone levels within normal ranges are not considered to be clinically adverse; however, they are indicative of a suppressing effect on thyroid hormone production that, if persistent, could result in thyroid gland enlargement and other clinically significant complications. The above conclusions apply to healthy adults who have no prior history of thyroid disease, no detectable antithyroid antibodies, and no prior history of chronic deficiency

3. HEALTH EFFECTS

or excessive iodine intakes (Gardner et al. 1988; Paul et al. 1988). One study found that subclinical hypothyroidism was induced by an acute increase of 500 µg/day (7 µg/kg/day) in elderly adults (Chow et al. 1991), suggesting the possibility that elderly adults may be less tolerant of an iodide excess than younger adults. Based on estimates of the background dietary intakes of the subjects in these studies, in most cases estimated from measurements of urinary iodide excretion, the total iodide intakes (including background dietary intake) that produced subclinical hypothyroidism were approximately 1,700 µg/day or approximately 24 µg/kg/day (Gardner et al. 1988; Paul et al. 1988). Acute intakes of approximately 700 µg/day or approximately 10 µg/kg/day had no detectable effect of thyroid hormone status in healthy individuals (Gardner et al. 1988; Paul et al. 1988). One study found no evidence for disturbances in thyroid hormone status in healthy adults who received doses of 300 µg/kg/day (approximately 20 mg/day) for 14 days (Robison et al. 1998). This suggests that, at least under certain conditions, exposure levels >10–24 µg/kg/day may be tolerated in some people. Brief summaries of the relevant studies that provide information on oral exposures to iodine that suppress the thyroid gland are provided below.

Healthy euthyroid adults (9 males, 9 females) who had no history of thyroid disease or detectable antithyroid antibodies received daily oral doses of 1,500 µg I/day as sodium iodide for 14 days (Paul et al. 1988). Based on 24-hour urinary excretion of iodide prior to the iodide supplement, the background iodine intake was estimated to be approximately 200 µg/day; thus, the total iodide intake was approximately 1,700 µg I/day (approximately 24 µg/kg/day, assuming a 70-kg body weight). Serum concentrations of TT₄, FT₄, and TT₃ were significantly depressed (5–10%) compared to pretreatment levels and serum TSH concentrations were significantly elevated (47%) compared to pretreatment values. Hormone levels were within the normal range during treatment and, therefore, the subjects were not clinically hypothyroid. In this same study, nine females received daily doses of 250 or 500 µg I/day for 14 days (total intake was approximately 450 or 700 µg/day [8 or 10 µg/kg/day] and there were no significant changes in serum hormone concentrations [some of these women participated in the higher dose study 1 year earlier]).

In a similar type of study, healthy, euthyroid, adult males (n=10) received daily oral doses of 500 µg I/day (as sodium iodide) for 14 days; there were no effects on serum thyroid hormone or TSH concentrations; however, dosages of 1,500 or 4,500 µg I/day (7 or 64 µg/kg/day) produced small (10%) but significant, transient decreases in serum TT₄ and FT₄ concentrations and an increase (48%) in serum TSH concentration, relative to the pretreatment values (Gardner et al. 1988). Urinary iodide excretion prior to the dose ranged from 250 to 320 µg/day, suggesting that the background dietary intake was approximately in this same range (see Sections 3.3.1.2 and 3.3.4.2). The magnitude of the changes at the higher iodide dosages yielded hormone concentrations that were within the normal range and, thus, would not represent a clinically significant thyroid suppression. This suggests that an acute oral intake of 500 µg/day above a preexisting dietary intake, or approximately 800 µg I/day total (11 µg/kg/day), is

3. HEALTH EFFECTS

tolerated without thyroid gland suppression in healthy adult males, and intakes as high as 4,800 µg I/day (69 µg/kg/day) may be tolerated in some people without clinically adverse effects.

In a similar type of study, 30 healthy elderly adult females, without evidence of thyroid peroxidase antibodies (TPA), received daily doses of 500 µg I/day (as potassium iodide) for 14 or 28 days (Chow et al. 1991). Serum concentrations of FT₄ were significantly decreased (change from pretreatment level, approximately -1 pmol/L) and serum TSH concentrations were significantly increased (change from pretreatment level approximately +0.6 mU/L) in the women who received the iodide supplements, relative to a placebo control group. On average, the magnitude of the changes did not produce clinically significant depression in thyroid hormone levels; however, five subjects had serum TSH concentrations that exceeded 5 mU/L, typically considered the high end of the normal range. The subjects had a lower dietary iodine intake than those in the Gardner et al. (1988) study; approximately 72–100 µg/day, based on urinary iodide measurements. Therefore, the total iodide intake was approximately 600 µg/day (9 µg/kg/day).

Higher acute iodine exposures have been shown to produce reversible thyroid gland hypertrophy, in addition to hormone suppression. The effects of tetraglycine hydroperiodide, an iodine compound used to purify drinking water, was examined in an acute experimental study (Georgitis et al. 1993). When dissolved in water, tetraglycine hydroperiodide releases I₂ and iodide (as a reduction product). Seven healthy adults, who had no history of thyroid disease, ingested 227 mL (8 ounces) of a flavored drink into which tetraglycine hydroperiodide had been dissolved; the dosage was 32 mg/day of iodine for 7 consecutive days (460 µg/kg/day). Seven age-, weight-, and height-matched controls received water without added iodine. A statistically significant decrease in serum concentration of T₄ and T₃ (14–15%) and a significant increase in TSH concentration (50%) occurred in the treatment group during the treatment, relative to their pretreatment values, whereas no change occurred in the control subjects. Two subjects in the treatment group had T₄ concentrations below approximately 60 nmol/L and two subjects had TSH concentrations that were between 4.5 and 6 mU/L, which would be indicative of mild clinical hypothyroidism (it is not clear from the report if these were the same two subjects). In a more extensive study of similar design, eight healthy euthyroid adults (seven males, one female), who were negative for thyroid antimicrosomal antibody, ingested approximately 32 mg iodine/day (460 µg/kg/day) as tetraglycine hydroperoxide dissolved in juice or water, for 90 days (LeMar et al. 1995). The mean pretreatment 24-hour urinary iodide excretion rate was 276 µg/day. Thyroid gland volumes increased significantly during the treatment, with a peak volume 37% above the pretreatment volume and reverted to pretreatment volumes 7 months after the iodine dosing was discontinued. Serum TSH concentrations increased significantly during the treatment, with one subject having a 3-fold increase to a value of 6.1 mU/L; this subject also had the highest thyroid volume during the treatment period. None of the subjects developed clinical hypothyroidism.

3. HEALTH EFFECTS

Daily doses of 27 mg I/day (390 µg/kg/day), as licorice lecithin-bound iodide, given for 28 days to 10 healthy, euthyroid adult males who were TPA negative resulted in a statistically significant, 15% increase in thyroid gland volume, compared to pretreatment values (Namba et al. 1993). Serum concentrations of FT₄ and T₃ were decreased, and serum TSH and thyroglobulin (T_g) concentrations were significantly elevated, although the treatment values were within the normal ranges. All values, including thyroid gland volume returned to normal within 28 days after the last iodide supplement. In a clinical study of 22 hypothyroid adults from Japan who consumed an estimated 1–43 mg I/day (17–720 µg/kg/day, from consumption of seaweed), 12 patients reverted to a euthyroid state after 3 weeks of voluntary dietary iodine restriction (Tajiri et al. 1986). When seven of these patients who converted to a euthyroid state after dietary restriction received supplements of 25 mg I/day (420 µg/kg/day) as Lugol's solution (a mixture of 50 mg/mL I₂ and 100 mg/mL potassium iodide KI) for 2–4 weeks, all reverted to a hypothyroid state (serum TSH concentrations >5 mU/L). In this same study, 11 healthy euthyroid adults (8 females, 3 males) received 25 mg I/day for 14 days (420 µg/kg/day). The mean serum TSH concentrations significantly increased (40%) during the treatment compared to their pretreatment values; however, their TSH concentrations during treatment (3.9 mU/L) did not exceed the normal range (<5 mU/L).

In contrast to the results of the above studies, no clinical abnormalities in thyroid hormone status occurred when healthy, euthyroid, adult males (n=6 or 7), who had no history of thyroid-related illness, ingested daily oral doses of 300 or 1,000 µg I/kg/day as either I₂ or sodium iodide for 14 days (Robison et al. 1998). Based on measurements of urinary iodide excretion rates, the pretreatment iodide intakes were approximately 100 µg/day. The high dosage (1,000 µg I/kg/day) produced a small but statistically significant increase in serum TSH concentrations compared to a sodium chloride control group; the TSH concentrations in the control group did not exceed the normal range (<5 mU/L) and reverted to control levels within 10 days after the iodine supplementation was ended. Serum TT₄ and TT₃ were not significantly different in the treatment groups, compared to the control group.

In a more remarkable, intermediate-duration experimental study, four healthy adults (three males, one female) received a daily oral dose of approximately 1,000 mg I/day as a saturated solution of potassium iodide (30 drops/day, approximately 36 mg I/drop, 15 mg I/kg/day) for 11 weeks (Jubiz et al. 1977). A small, statistically significant decrease in the mean serum concentration of T₄ occurred (pretreatment, 8.8 µg/dL; treatment minimum 7.6 µg/dL) and an increase in TSH concentration (pretreatment, 7.3 mU/L; treatment maximum, 13.5 mU/L). The above changes were no longer evident within 1 week after the treatment was discontinued. In a similar study, eight euthyroid adults (seven male, one female), who were hepatitis patients, received daily oral doses of approximately 360 mg I/day (5 mg/kg/day) as a saturated solution of potassium iodide (10 drops/day, approximately 36 mg I/drop) for 60 days (Minelli et al. 1999). A small statistically significant decrease in the mean serum concentration of T₄ (pretreatment,

3. HEALTH EFFECTS

13.8 pmol/L; treatment minimum 13.2 pmol/L) and an increase in TSH concentration (pretreatment, 0.6 mU/L; treatment maximum, 1.7 mU/L) occurred. Two patients were reported to have developed transient elevated serum TSH concentrations during the iodide treatment, with normal concentrations of FT₄ and FT₃. There were no incidences of clinical hypothyroidism or hyperthyroidism. A nearly identical result was reported for eight euthyroid hepatitis patients who had previously received recombinant interferon-alpha therapy (but who did not develop thyroid dysfunction during therapy) and who subsequently received daily doses of approximately 360 mg I/day (5 mg/kg/day) as a saturated solution of potassium iodide for 60 days (Minelli et al. 1997). As part of the study reported by Jubiz et al. (1977), 13 patients with obstructive pulmonary disease who were receiving 1,000–2,000 mg I/day (14–28 mg/kg/day) as a saturated potassium iodide solution for periods of 1 month to 8 years exhibited unambiguous symptoms of hypothyroidism, including thyroid gland enlargement, depressed serum concentrations of T₄ (mean 2–2.7 µg/dL), and elevated serum TSH concentrations (20–35 mU/L). Serum T₄ and TSH levels returned to normal in all but one of the patients within 1 month after the iodide dosage was discontinued.

The results of several epidemiological studies suggest that chronic exposure to excess iodine can result in or contribute to hypothyroidism. Thyroid status was compared in groups of children, ages 7–15 years, who resided in two areas of China where drinking water iodide concentrations were either 462 µg/L (n=120) or 54 µg/L (n=51) (Boyages et al. 1989; Li et al. 1987). Although the subjects were all euthyroid with normal values for serum thyroid hormones and TSH concentrations, TSH concentrations were significantly higher in the high iodine group. The prevalence and severity of goiter in the population were evaluated, the latter based on a goiter severity classification scale (Grade 0, no visible goiter; Grade 1, palpable goiter that is not visible when the neck is not extended; Grade 2, palpable and visible goiter when the neck is not extended). The high iodide group had a 65% prevalence of goiter compared to 15% in the low iodine group. The prevalence of more severe, Grade 2 goiter, was also higher in the high iodide group (15%) compared to the low iodide group (0%). Urinary iodine was 1,236 µg I/g creatinine in the high iodine group and 428 µg I/g creatinine in the low iodine group. Assuming a body weight of 40 kg and lean body mass of 85% of body weight, the above urinary iodine/creatinine ratios are approximately equivalent to iodine excretion rates or steady state ingestion rates of 1,150 µg/day (29 µg/kg/day) and 400 µg/day (10 µg/kg/day) in the high and low iodide groups, respectively.

A survey of a group of Peace Corps volunteers revealed a high prevalence of goiter among volunteers who drank water from iodine filters (Khan et al. 1998). Of 96 volunteers surveyed, 44 (46%) had enlarged thyroid glands, 33 (34%) had elevated serum TSH concentrations (≥4.2 mU/L), and 4 (4%) had depressed serum TSH concentrations (<0.4 mU/L). The mean iodide concentration in filtered drinking water was 10 mg I/L, which corresponded to a daily intake of iodide from drinking water of 50–90 mg I/day (0.7–1.3 mg/kg/day, based on a reported daily water consumption of 5–9 L/day). This estimate was

3. HEALTH EFFECTS

consistent with measured mean urinary iodide concentration of 11 mg/L, which corresponds to approximately 55–99 mg I/day excreted or ingested, assuming daily urine volumes similar to water consumption.

In a study of elderly adults, thyroid status was compared in 423 residents (ages 66–70 years) of Jutland, Denmark who had iodine intakes of 40–60 µg/day (0.7 µg/kg/day) and 100 residents of Iceland who had intakes of 300–350 µg/day (5 µg/kg/day) (Laurberg et al. 1998). Subjects from the high iodine intake region had a significantly higher prevalence (18%) of serum TSH levels above the high end of the normal range (>4 mU/L) compared to subjects from the low iodine region (3.8%). The prevalence of serum TSH concentrations above 10 mU/L was 4.0% in the high iodine region and 0.9% in the low iodine region. Females in both regions had a significantly higher prevalence of elevated TSH concentrations than males. Serum concentrations of T₄ were not depressed, even in subjects with TSH concentrations that exceeded 10 mU/L. Thus, although the subjects appeared to be euthyroid, the higher iodine intakes were associated with a subclinical suppression of the thyroid gland as indicated by a high prevalence of elevated serum TSH concentrations. A study of elderly nursing home residents in the Carpathian Basin also revealed a prevalence of hypothyroidism that increased with increasing iodine intake (Szabolcs et al. 1997). Subjects were from one of three regions where, based on reported urinary iodine levels of 72, 100, or 513 µg I/g creatinine, the iodine intakes were approximately 117, 163, or 834 µg/day (1.7, 2.3, or 12 µg/kg/day for low, n=119; moderate, n=135; or high intake, n=92, respectively). The prevalence of serum TSH concentrations above the normal range was 4.2, 10.4, and 23.9% in the low, moderate, and high iodine groups, respectively. The prevalence of elevated serum TSH concentrations together with serum FT₄ concentrations below the normal range was 0.95, 1.5, and 7.6% in the low, moderate, and high iodine groups, respectively.

Several studies have found increased prevalence of hypothyroidism in residents of areas of Japan where dietary iodine intake is high as a result of consumption of seaweeds containing a high iodine concentration. In one study, urinary iodide and serum TSH concentrations were measured in a group of 1,061 adult residents of five coastal areas of Japan and in 4,100 residents of two inland areas (Konno et al. 1993a, 1994). The subjects were classified as having high or normal iodine intakes based on whether their urinary iodide concentrations were less than or greater than the high end of the *normal range*, 75 µmol/L (9,500 µg/L). The urine samples were not timed and urinary creatinine concentrations were not reported; therefore, only rough estimates of the rate of urinary excretion of iodide (µg/day) and iodide intake can be made. The report indicates that the urine samples were collected in the morning and included night urine (i.e., urine voided on awakening). If it is assumed that the concentrations of iodide in the morning urine samples reflect the concentration for a 24-hour sample and that the 24-hour urine volume is approximately 1.4 L (ICRP 1981), then the 24-hour excretion and intake rates in the high iodine group may have been approximately 13.3 mg/day (0.22 mg/kg/day, assuming a body weight of

3. HEALTH EFFECTS

60 kg). Even if the morning urine samples were relatively concentrated compared to the 24-hour average, the above urine iodide concentrations suggest an iodide intake of several mg/day. This is consistent with other reported estimates that range from 1 to 5 mg/day in Japan among consumers of seaweed (Pennington 1990b). Examples of much higher intakes (25–40 mg/day, 0.4–0.7 mg/kg/day) have been reported in hypothyroid patients who consume seaweed (Tajiri et al. 1986). The prevalences of elevated serum TSH concentrations (>5 mU/L) and urine iodide concentrations (>9,500 µg/L) were both significantly higher in the coastal regions compared to the inland regions (Konno et al. 1994). Serum TSH concentrations were positively correlated with the urine iodide concentrations, and the prevalence of elevated serum TSH concentrations in the seven areas correlated positively with the prevalence of high urinary iodide concentrations. There were no significant correlations or associations with urine iodide and suppressed concentrations of serum TSH (<0.15 mU/L) or with the presence of thyroid antibodies.

A study of iodine supplementation for treatment of endemic goiter provides additional evidence that increases in iodine intake can induce thyroid dysfunction, including thyroid autoimmunity. Otherwise healthy adults who had goiter but no evidence of clinical hypothyroidism or hyperthyroidism or antithyroid antibodies received either a placebo (16 females, 15 males) or 200 mg I/day (3 µg/kg/day total intake) (16 females, 15 males) as potassium iodide for 12 months (Kahaly et al. 1997). A significant decrease in thyroid volume occurred in the treated group relative to the control group. Three subjects in the treatment group (9.7%, two females and one male) developed elevated levels of thyroglobulin and thyroid microsomal antibodies compared to none in the control group. Two of these subjects developed hypothyroidism and one subject developed hyperthyroidism; all three subjects reverted to normal thyroid hormone status when the iodide supplementation was discontinued. In a similar study, 31 adult euthyroid patients from an endemic goiter region who had goiter received 500 µg/day potassium iodide (382 mg I/day, 5 mg I/kg/day based on reported median body weight of 75 kg) for 6 months, and 31 patients received 0.125 mg T₄/day (Kahaly et al. 1998). Based on reported measurements of 24-hour urine iodide excretion, the preexisting iodide intake was approximately 40 µg/day (range, 13–77, 0.6 µg/kg/day); thus, the total intake during treatment was approximately 420 mg I/day (6 µg/kg/day). After 6 months of iodide supplementation, the mean 24-hour urinary iodide excretion rate was 415 µg/day, which is consistent with the estimate of a total iodide intake of approximately 420 µg/day. Six of the patients who received iodide (19%) developed high titres of thyroglobulin and thyroid microsomal antibodies, compared to none in the T₄ group. Four of the high antibody patients became hypothyroid and two patients became hyperthyroid. The thyroid hormone status reverted to normal and antibody titres decreased during a 6-month period following the treatment in which the patients received a placebo.

People who have autoimmune thyroid disease may be at increased risk of developing thyroid dysfunction when exposed to excess iodide. Euthyroid patients (37 females, 3 males), who were diagnosed with Hashimoto's thyroiditis and who were positive for antithyroid (thyroid peroxidase) antibodies, received

3. HEALTH EFFECTS

an oral dose of 250 µg potassium iodide (190 µg I/day) for 4 months; a similar group of thyroiditis patients (41 females, 2 males) served as controls (Reinhardt et al. 1998). Based on urinary iodide measurements of 72 µg I/g creatinine before the iodide supplementation, the preexisting iodide intake was approximately 125 µg/day, for a total iodide dosage of 375 µg/day (4.5 µg/kg/day) in the treatment group. Seven patients in the treatment group developed elevated serum TSH concentration (>4 mU/L) and one patient developed overt clinical hypothyroidism with a TSH concentration of 43.3 mU/L and a serum FT₄ concentration of 7 pmol/L. One patient in the treatment group became clinically hyperthyroid with a serum FT₄ concentration of 30 pmol/L and TSH concentration of <1 mU/L. One patient in the control group developed mild subclinical hypothyroidism. After the iodine supplementation was discontinued, three of the seven hypothyroid patients in the treatment group reverted to normal thyroid. An additional patient in the treatment group became hypothyroid, requiring T₄ supplements. The patient who became hyperthyroid while in the treatment group reverted to normal thyroid status after the iodide supplements were discontinued. In a smaller clinical study, four of seven euthyroid patients with Hashimoto's thyroiditis who received 180 mg I/day (2.6 mg/kg/day) as a saturated potassium iodide solution for 6 weeks developed hypothyroidism, which reverted to normal after the iodide supplementation was discontinued (Braverman et al. 1971a).

Maternal exposures to excess iodine during pregnancy have been shown to produce goiter and hypothyroidism in neonates. In general, clinical cases have involved maternal exposures to several hundred mg I/day during pregnancy. For example, in one clinical case, hypothyroidism and life-threatening goiter occurred in an infant born to a woman who consumed approximately 200 mg I/day (2.9 mg/kg/day), as sodium iodide, for 2 years, including during pregnancy (Iancu et al. 1974). The infant was treated with levothyroxine and reverted to a normal gland and hormone status within 3 weeks after birth, without further hormone therapy. In another case, a woman ingested approximately 260–390 mg I/day (4.6 mg/kg/day) during pregnancy and her infant developed goiter *in utero*, which was successfully treated *in utero* with levothyroxine; the thyroid gland and hormone status of the infant was normal at birth (Vicens-Colvet et al. 1998). Coakley et al. (1989) reported, as part of the results of a screening program for congenital hypothyroidism, two cases in which women ingested iodide during pregnancy and gave birth to infants who had a transient goiter. In one case, the estimated total dose iodide dose was approximately 38.3 g I, of which approximately 15.3 g was ingested during the last month of pregnancy. These doses are equivalent to an average daily total dose of approximately 96 mg I/day during the first 8 months and 510 mg I/day (7.3 mg/kg/day) during the last month of pregnancy. Penfold et al. (1978) reported two cases, one of goiter without hypothyroidism in an infant born to a mother who ingested approximately 380 mg I/day (5.4 mg/kg/day) as potassium iodide during the last trimester of pregnancy, and the other case of goiter with hypothyroidism in an infant born to a mother who had ingested approximately 460 mg I/day (6.6 mg/kg/day) as potassium iodide during the last 4 months of pregnancy. In both cases, hypothyroidism and/or goiter were temporary and did not require

3. HEALTH EFFECTS

thyroid hormone therapy. Hassan et al. (1968) reported three cases of neonatal goiter and hypothyroidism. In each case, the mother had ingested daily doses of potassium iodide during pregnancy; approximate doses were 450, 688, and 765 mg I/day (6–11 mg/kg/day). The goiter and hypothyroidism reversed with temporary thyroid hormone therapy. Martin and Rento (1962) reported two cases of goiter and severe but reversible hypothyroidism in infants born to mothers who ingested potassium iodide during pregnancy; the approximate dosages were 920 and 1,530 mg I/day (13 and 22 mg/kg/day). In two cases, infants died with complications related to a goiterous thyroid gland compression of the trachea; the mothers had ingested potassium iodide during their pregnancies at doses of approximately 850 and 1,180 mg I/day (12 and 17 mg/kg/day) (Galina et al. 1962).

The above clinical cases demonstrate that doses of iodide exceeding 200 mg/day (2.8 mg/kg/day) during pregnancy can result in congenital goiter and hypothyroidism. There is also a large clinical experience with the lower doses of iodide supplementation given during pregnancy for the purpose of correcting or preventing potential iodine deficiency and for the management of Graves' disease during pregnancy. In a study of 35 women with Graves' disease who received 6–40 mg iodide (0.1–0.7 mg/kg/day, assuming a 60-kg body weight) as potassium iodide during pregnancy, 2 of 35 infants had serum TSH concentrations above normal at birth (>20 mU/L) and none had FT₄ concentrations below normal at birth (<10 pmol/L; 7 ng/L), suggesting that this level of iodide supplementation did not induce a hypothyroid state in the newborn, but did produce a subclinical change in TSH levels in some infants (Momotani et al. 1992). In a study of iodide supplementation during pregnancy in an iodide-deficient area of Denmark, 28 women received daily doses of 200 µg I/day from the 17th–18th week of pregnancy through the first 12 months after delivery and 26 women received no supplementation (Pedersen et al. 1993). Pretreatment urinary iodide levels were 51 and 55 µg/L, respectively, in the two groups, suggesting a preexisting dietary iodine intake of approximately 75 µg/day (assuming that the urine iodide concentration reflected the 24-hour average and that urine volume was approximately 1.4 L/day) and a total iodide intake of 275 µg/day (4 µg/kg/day). There were no statistically significant differences in serum TT₄, FT₄, T₃, or TSH concentrations in the infants in the two groups at birth, and there were no abnormal values for the hormones in any of the infants. In a similar type of study, 38 pregnant women from a potentially iodine-deficient region of Germany received daily doses of 230 µg I/day as potassium iodide during pregnancy and lactation and 70 women received no supplementation. Pretreatment urinary iodide levels were 53 µg I/g creatinine (median), suggesting a preexisting iodide intake of approximately 90 µg/day (Liesenkötter et al. 1996) and a total intake of 320 µg/day (5 µg/kg/day). Thyroid gland volumes were significantly decreased in infants from the supplemented group, compared to the control group (median control, 1.5 mL; median treated, 0.7 mL). One infant (1/38, 2.6%) from the supplemented group was classified as having an enlarged gland (>1.5 mL) compared to 14 (14/70, 20%) from the control group. The report indicates that *“no hypothyroidism or hyperthyroidism was observed in the mothers or newborns”*, although the end points evaluated, other than serum TSH, were not indicated.

3. HEALTH EFFECTS

Iodized oil has been used to supplement intakes in populations that are iodine deficient and live in areas where supplementation with iodized table salt or drinking water is not practical. Iodized oil (ethiodiol) consists of a mixture of covalently iodinated fatty acids of poppy seed oil; the iodine content is approximately 38% by weight. Iodine in iodized oil is taken up in adipose tissue and has a much longer retention time in the body than iodide salts; thus, epidemiological studies of iodized oil cannot be directly compared to those of iodide. Nevertheless, the studies provide some useful information on oral exposures to iodine that are tolerated during pregnancy without apparent adverse consequences to the fetal or neonatal thyroid. Delange (1996) reviewed epidemiological studies in which iodized oil was administered just prior to and/or during pregnancy to prevent maternal and neonatal hypothyroidism. A study of an iodine-deficient population in Algeria (with a 53% prevalence of goiter and 1% prevalence of congenital cretinism) compared thyroid status in infants born to mothers who received a placebo or a single oral dose of 240 mg I (3.4 mg/kg), as iodized oil, either 1–3 months prior to conception, during the first month of pregnancy, or during the third month of pregnancy. Neonatal serum concentrations of TSH were significantly lower in the treated groups compared to controls (treated, 4.6–4.9 mU/L; placebo, 12.4 mU/L) and serum T₄ concentrations were significantly higher compared to controls (treated, 10.4–11 µg/dL; placebo, 6.7 µg/dL). The incidence of infant hypothyroidism was 0 in 554 infants; the incidence in the placebo control was 2 in 982 (0.2%). A similar outcome occurred in a population from an iodine-deficient region of Malawi (59% prevalence of goiter, 1% incidence of cretinism), where pregnant women received either a placebo or an oral dose of 240 mg I as iodized oil (Delange 1996).

Hyperthyroidism.

Oral exposure to excess iodide can, under certain circumstances, induce hyperthyroidism and thyrotoxicosis. The epidemiological and clinical literature suggest that this disorder occurs most often in people who have a previous history of iodine deficiency, goiter, or thyroid diseases including postpartum thyroiditis or Graves' disease (Braverman and Roti 1996; Fradkin and Wolff 1983; Leger et al. 1984; Paschke et al. 1994). Cases of iodine-induced hyperthyroidism in people who were euthyroid and without apparent thyroid disease have been reported (Rajatanavin et al. 1984; Savoie et al. 1975; Shilo and Hirsch 1986); however, only a few have provided dose information. In one case, a 72-year-old female without apparent preexisting thyroid disease developed clinical hyperthyroidism after ingesting approximately 2.8–4.2 mg iodine/day (0.05 mg/kg/day) in the form of sea-kelp tablets; her thyroid status reverted to normal within 6 months after she stopped taking the tablets (Shilo and Hirsch 1986). In another case, a 15-year-old male developed hyperthyroidism and thyrotoxicosis after receiving 1,440 mg I/day (23 mg/kg/day) as a saturated solution of potassium iodide for 4 months (Ahmed et al. 1974). The thyroid status reverted to normal within 6 months after the potassium iodide was discontinued.

3. HEALTH EFFECTS

In a clinical study, eight healthy adult euthyroid females, who had nontoxic goiter, received oral doses of 180 mg I/day (2.6 mg/kg/day) as a saturated potassium iodide solution for 10–18 weeks (Vagenakis et al. 1972). Four of the eight patients developed clinical hyperthyroidism and thyrotoxicosis. Two patients developed thyrotoxicosis within 7–10 weeks after supplementation began, which became more serious after supplementation was discontinued. One patient developed clinical hyperthyroidism after 10 weeks of supplementation and then became overtly thyrotoxic after the iodide supplementation was stopped. A fourth patient developed subclinical hyperthyroidism during iodide treatment and became clinically hyperthyroid with thyrotoxicosis after supplementation was stopped.

What has been referred to as an *epidemic* of hyperthyroidism occurred in the midwestern United States between the years 1926 and 1928 (Kohn 1975, 1976). Clinical records suggest that the incidence of mortality from hyperthyroidism increased in Detroit during this period from approximately 2–4 deaths per 100,000 to approximately 11 deaths per 100,000 at the peak of the epidemic. Although there is considerable debate about the origins of the epidemic, the advent of aggressive supplementation of the diet with iodide in midwestern endemic goiter areas has been implicated as a contributing factor. More recent and more rigorous epidemiologic designs have been applied to several populations in which dietary iodide was supplemented as a prophylaxis for iodine deficiency and goiter (Lind et al. 1998; Stanbury et al. 1998). These studies confirm that iodide supplementation of iodide-deficient diets does indeed result in a detectable increase in incidence of hyperthyroidism.

In an epidemiology study conducted in Austria, the annual incidence of hyperthyroidism was evaluated in patients examined at nuclear medicine centers (where all thyroid examinations are conducted in Austria) before and after an upward adjustment was made in the use of iodized table salt in 1991 (Mostbeck et al. 1998). The mean urinary iodide concentration before the adjustment was 42–78 µg I/g creatinine and after the adjustment was 120–140 µg I/g creatinine; these are approximately equivalent to 77–146 µg/day (1.1–2.1 µg/kg/day) and 225–263 µg/day (3.2–3.8 µg/kg/day), respectively. The analysis included 392,820 patients examined between 1987 and 1995 in 19 nuclear medicine centers. A significant relative risk of hyperthyroidism, both for Graves' disease and intrinsic thyroid autonomy, was found when the annual incidences of each in the postadjustment period (1991–1995) were compared to the preadjustment period (1987–1989). The highest relative risks were for Graves' disease which were 2.19 (2.01–2.38, 95% confidence interval [CI]) for overt clinical disease and 2.47 (2.04–3.00) for subclinical disease. A regression analysis of the pre- and postadjustment incidences found a significant increasing trend for hyperthyroidism of both types in the postadjustment period and no trend in the preadjustment period. When the postadjustment incidence data were stratified by time periods 1990–1992 or 1993–1995, and by sex and age, higher relative risks were evident for intrinsic thyroid autonomy among males compared to females and in subjects older than 50 years compared to younger than 50 years. The incidence for

3. HEALTH EFFECTS

hyperthyroidism (all forms of overt or subclinical) was 70.1 per 100,000 in the preadjustment period and reached a peak of 108.4 per 100,000 in 1992, after the adjustment.

Data collected on the incidence of hyperthyroidism in Tasmania also show that a 2- to 4-fold increase in hyperthyroidism cases occurred within a few months after diets were supplemented with iodide for preventing endemic goiter from iodide deficiency (Connolly et al. 1970). The approximate supplemental dose was 80–200 $\mu\text{g}/\text{day}$ from the addition to potassium iodide to bread. Mean 24-hour urinary iodide excretion rates suggested a total postsupplementation iodide intake of approximately 230 $\mu\text{g}/\text{day}$ (range, 94–398, 3.3 $\mu\text{g}/\text{kg}/\text{day}$), some of which may have come from sources other than supplemented bread (Connolly 1971a, 1971b). The highest incidence of hyperthyroidism after the iodine supplementation began occurred in people over 50 years of age (Stewart 1975; Stewart and Vidor 1976).

A large multinational epidemiological study was conducted in Africa to evaluate the effectiveness and possible adverse consequences of the introduction of iodized salt into diets of populations residing in iodine-deficient and endemic goiter regions of Africa (DeLange et al. 1999). In each study area, urine and table salt were collected from a group of 100–400 randomly-selected children, ages 6–14 years. Health care facilities were surveyed for information on thyroid disease in each area. In Zimbabwe, the incidence of hyperthyroidism increased by a factor of 2.6 within 18 months after the widespread introduction of iodized salt into the diet (from 2.8 in 100,000 to 7.4 in 100,000). Females accounted for 90% of the cases, with the highest incidence in the age group 60–69 years. The most common disorders were toxic nodular goiter (58%) and Graves' disease (27%) (Todd et al. 1995). Urinary iodide concentrations in children increased by a factor of 5–10 over this time period. Urine samples were reported as "casual samples" and, thus, there is a large uncertainty in translating the concentrations into intakes. Median urine iodide concentrations ranged from 290 to 560 $\mu\text{g}/\text{L}$. Reported estimates of iodide intake from salt and seafood were 500 $\mu\text{g}/\text{day}$ (7.1 $\mu\text{g}/\text{kg}/\text{day}$) and 15–100 $\mu\text{g}/\text{day}$ (0.7 $\mu\text{g}/\text{kg}/\text{day}$), respectively. Increased numbers of cases of thyrotoxicosis along with an increase in urinary iodide levels (from 16 to 240 $\mu\text{g}/\text{L}$) occurred after iodized salt was introduced into the diet of an iodine-deficient population in the Kivu region of Zaire (Bourdoux et al. 1996).

An epidemiological study in Switzerland examined the incidence of hyperthyroidism before and after the iodine content of salt was increased from 7.5 to 15 mg/kg (Baltisberger et al. 1995; Bürgi et al. 1998). The study population included 109,000 people. The mean urinary iodide concentration was 90 $\mu\text{g}/\text{I/g}$ creatinine before the supplementation and 150 $\mu\text{g}/\text{I/g}$ creatinine after the supplementation. This is equivalent to an increase in intake from approximately 170 to 280 $\mu\text{g}/\text{I}/\text{day}$ (4 $\mu\text{g}/\text{kg}/\text{day}$), assuming a body weight of 70 kg. During the first year after supplementation began, the combined annual incidence of hyperthyroidism diagnosed as either Graves' disease or toxic nodular goiter increased by 27% (from 62.3/100,000 to approximately 80/100,000). Subsequent to this increase, the incidence of

3. HEALTH EFFECTS

hyperthyroidism steadily declined to 44% of the presupplementation rates, with most of the decrease resulting from a decline in incidence of toxic nodular goiter.

In an experimental study, adults with goiter who lived in an iodine-deficient region of Sudan received a single oral dose of 200, 400, or 800 mg iodine (3–11 mg/kg/day) as iodine oil (37–41 subjects per dose group) and their thyroid status was evaluated for a period of 12 months (Elnagar et al. 1995).

Approximately half of the subjects were clinically hypothyroid with serum T₄ concentrations <50 nmol/L and TSH concentrations >4 mU/L. One week after the iodine oil was administered, there was a dose-related increase in the incidence of serum TSH concentrations; 1 in 41 (2.5%) in the low-dose group, 3 in 37 (8.1%) in the middle-dose group, and 10 in 39 (25.6%) in the high-dose group, although the number of subjects exceeding 4 mU/L was not dose-related. One subject in the low-dose group and three subjects in the high-dose group became hyperthyroid during the observation period. One of the high-dose subjects remained hyperthyroid 1 year after the dose of iodine oil.

Effects of Radioiodine on the Thyroid Gland.

Extensive clinical use of radioiodine, principally ¹²³I and ¹³¹I, for diagnostic purposes and for treatment of thyrotoxicosis has provided a wealth of information on the effects of relatively high acute exposures on thyroid gland function. Radioiodine is cytotoxic to the thyroid gland and produces hypothyroidism at absorbed effective doses to the thyroid gland exceeding 2,500 rad (25 Gy). Thyroid gland doses of approximately 30,000 rad (300 Gy) can completely ablate the thyroid gland. This dose is achieved with an acute exposure of approximately 25–250 mCi (0.9–9 GBq) (Maxon and Saenger 2000). Doses this high are administered for the treatment of thyroid cancer. Smaller doses are generally used in the treatment of hyperthyroidism (10–20 mCi, 370–740 MBq; 5,000–12,000 rad, 50–120 Gy). Diagnostic uses of radioiodine involve much smaller exposures and doses, typically 0.1–0.4 mCi (4–15 MBq) of ¹²³I or 0.005–0.01 mCi ¹³¹I (0.2–0.4 MBq). These exposures correspond to approximate thyroid radiation doses of 1–5 rad (1–5 cGy) and 6–13 rad (6–13 cGy) for ¹²³I and ¹³¹I, respectively (McDougall and Cavalieri 2000).

Several epidemiological studies have examined the relationship between oral exposure to ¹³¹I and thyroid gland nodularity. Thyroid nodules are irregular growths of the thyroid gland tissue that can be benign or cancerous. Nodules can be detected by physical palpation of the gland or by various imaging techniques. Palpation detects only larger (>1 cm) nodules, whereas ultrasound can detect nodules that are not palpable (e.g., 10 mm or less). The complete description of a study by Kerber et al. (1993) is provided in Section 3.2.2.7, as it primarily relates to thyroid neoplasms. The study reported no difference in prevalence of thyroid nodularity detected by physical examination in a cohort living near the NTS when compared to a nonexposed cohort living remote from the NTS. However, when the thyroid radiation dose

3. HEALTH EFFECTS

from ^{131}I was calculated for each subject in each location, there was a correlation between radiation dose and formation of neoplasia of the thyroid, but not to nonneoplastic nodules (Kerber et al. 1993). The Hall et al. (1996a) study evaluated 1,005 women for thyroid nodularity who had been exposed to diagnostic levels of ^{131}I during the period 1952–1977 and whose diagnosis for thyroid abnormalities were negative. The subjects were evaluated for palpable thyroid nodules during the period 1991–1992. A comparison group consisted of 248 women who attended a mammography screening clinic with no prior history of exposure to ^{131}I or thyroid disease. The average total administered ^{131}I activity was 0.95 MBq (26 μCi). Absorbed radiation doses to the thyroid gland were estimated based on the administered activity and dosimetry tables from International Commission on Radiological Protection (ICRP 1988). The average dose was 0.54 Gy (54 rad) (10th–90th percentiles, 0.02–1.45 Gy; 2–145 rad). Thyroid nodules were detected in 107 of 1,005 (10.6%) exposed women and 29 of 248 (11.7%) nonexposed women. The relative risk (RR, based on odds ratios [ORs]) for thyroid nodularity for women exposed to ^{131}I was 0.9 (95% CI, 0.6–1.4) and was not statistically significant. A linear quadratic excess relative risk model revealed a statistically significant dose trend for thyroid nodularity (excess RR, 0.9/Gy). Hall et al. (1996a) suggest as an explanation for the lack of a significant RR for thyroid nodularity that the nonexposed control group was self-selected (i.e., the subjects voluntarily sought mammographic screening) and, therefore, may not have been an appropriate control group for comparison to the group of women who received radioiodine.

Clinical cases have been reported in which congenital hypothyroidism occurred after maternal exposures to high doses of ^{131}I for treatment of thyroid gland tumors (Green et al. 1971; Hamill et al. 1961; Jafek et al. 1974; Russell et al. 1957). However, the complex clinical picture and pharmacotherapy of the mothers for their thyroid condition during pregnancy makes direct associations between the radioiodine exposure and the clinical outcomes of the newborns highly uncertain. Exposures in these case ranged from 11 to 77 mCi (0.4–2.8 GBq). Effects on the fetal and newborn thyroid would be expected if mothers received ablative doses of ^{131}I during pregnancy after approximately 12 weeks of gestation, when the fetal thyroid begins to take up iodide. A study of 73 infants and children born to 70 patients who received ^{131}I for ablative treatment of thyroid cancer 2–10 years (mean, 5.3 years) prior to pregnancy found no thyroid gland disorders (Casara et al. 1993). The maternal ^{131}I exposures ranged from 1.85 to 16.55 GBq (50–400 mCi); the mean exposure was 4.40 GBq (120 mCi). A similar finding was reported in a study of 37 patients (47 infants) who received ^{131}I , 1–60 months prior to conception (mean, 16.5 months); exposures ranged from 1.1 to 13.1 GBq (30–350 mCi), with a mean exposure of 3.67 GBq (100 mCi) (Lin et al. 1998).

Marshall Islands. Shortly after the BRAVO test, residents on three of the Marshall Islands were identified as having been exposed to external gamma radiation during the 2 days prior to their evacuation (Conard 1984): 64 residents of Rongelap (1.90 Gy, 190 rad), 18 residents of Ailingnae (1.10 Gy, 110 rad)

3. HEALTH EFFECTS

and 150 residents of Utirik (0.11 Gy, 11 rad). Estimated total absorbed doses to the thyroid gland (external and internal) were 3.3–20 Gy (300–2,000 rad) on Rongelap (highest doses in children), 1.3–4.5 Gy (130–450 rad) on Ailingnae, and 0.3–0.95 Gy (30–95 rad) on Utirik (Conard 1984). As part of a medical evaluation program, these individuals, the so-called BRAVO cohort, were evaluated periodically for health consequences of their exposures. Evidence of acute radiation sickness was prevalent early after exposures, including nausea and vomiting, hematological suppression, and dermal radiation burns. Cases of thyroid gland disorders began to be detected in the exposed population in 1964, 10 years after the exposure, particularly in exposed children; these included cases of apparent growth retardation, myxedema, and thyroid gland neoplasms (Conard et al. 1970). In 1981, when the children from Rongelap island were screened, it was discovered that 83% of the children who were <1 year of age at the time of the BRAVO test were found to have evidence of hypothyroidism (i.e., a serum concentration of TSH >5mU/L). This group of children had received an estimated thyroid dose exceeding 1,500 rad (15 Gy). Prevalence and thyroid radiation dose decreased with exposure age: 25% for ages 2–10 years (800–1,500 rad, 8–15 Gy) and 9% for ages >10 years (335–800 rad, 3.35–8.00 Gy). Prevalences in the exposed groups from Ailingnae were 8% for exposure ages >10 years (135–190 rad, 1.35–1.90 Gy) and 1% on Utirik (30–60 rad, 0.3–0.6 Gy). These prevalences are consistent with the apparent dose-response relationship for the Rongelap group. In an unexposed group (Rongelap residents who were not on the island at the time of the BRAVO test), the prevalence was 0.3–0.4% (Conard 1984). At about the same time, in 1964, cases of palpable thyroid gland nodules began to be identified in health screening programs (Conard 1984). The prevalence of thyroid nodularity had an age/dose profile similar to that of thyroid hypofunction (i.e., elevated serum TSH). In 1981, thyroid nodules were found in 67–81% Rongelap residents exposed before the age of 10 years and in 13% of those exposed after 10 years. Prevalence in the Ailingnae populations was 29% in the population of children exposed before age 10 years and 33% in the population exposed after age 10 years. In the Utirik population, the prevalence of thyroid nodules was 8% in the population of children exposed before age 10 years and 12% in the population exposed after age 10 years. The prevalence of thyroid gland carcinoma, mainly papillary carcinomas, also appeared to be elevated in the exposed Rongelap population (6%) compared to the unexposed group (1%). In 1994, thyroid ultrasound examinations were performed on 117 of the original exposure group, 47 from Rongelap, and 70 for Utirik, and 47 residents of Rongelap who were on Majuro at the time of the BRAVO test, approximately 480 miles south of the test site on Bikini Atoll (Howard et al. 1997). Over the period 1965–1990, the case rate for thyroid nodules was approximately 3–8% per year in the exposed groups and approximately 3 times greater in females than in males. However, the 1994 ultrasound evaluations found relatively high, but not significantly different prevalences of thyroid nodules in exposed (12–33%) and nonexposed (25%) groups or between males and females (Howard et al. 1997). The differences in the outcomes in 1994 and earlier may reflect the age differences at the time of examination, or possibly that palpation detects only larger (>1 cm) nodules, whereas ultrasound can detect nodules that are not palpable (e.g., 10 mm or less). Ultrasound is more

3. HEALTH EFFECTS

likely to detect clinically insignificant *nodules* that are actually normal variants of thyroid tissue. Another possible contributor to the differences between outcomes is that earlier studies may have been biased by greater screening/surveillance intensity given to the high-dose groups, whereas the Howard et al. (1997) study was a more systematic comparison across the dose range and used a more objective ultrasound criteria for diagnosing nodularity. Thyroid nodule incidence is highly susceptible to surveillance effects and these studies were not adequately controlled for such effects. A possibly related observation is an apparent high prevalence of iodine deficiency in the Marshall Islands, which may have contributed to a high background prevalence of nodular goiter (Hermus and Huysmans 2000; Takahashi et al. 1999).

A retrospective cohort study reexamined the prevalence of thyroid gland nodularity reported in the 1980s among residents of the Marshall Islands who were potentially exposed to ¹³¹I from atmospheric fallout from the BRAVO test in 1954 (Hamilton et al. 1987). This study included residents on islands located 112–589 miles from the test site. The cohort consisted of 7,266 people known to have been residents on the islands (or *in utero*) in 1954 at the time of the BRAVO test. Each subject was examined for palpable thyroid nodules during the period 1983–1985. The examiners were blind to the estimated thyroid radiation dose received by each subject. Radiation doses to the thyroid gland were estimated to have been 21 Gy (2,100 rad) for residents of Rongelap (120 miles from the test site) and 2.80 Gy (280 rad) for residents of Utirik (321 miles). Residents of 12 other islands, who historically were thought not to have received exposures to radioiodine based on location (distance and/or position with respect to prevailing winds), were included in the study. The age-adjusted prevalence of thyroid nodularity was 37% among residents of Rongelap Island and 10.3% for Utirik Island. Prevalence among residents of the other 12 islands ranged from 0.8 to 10.2% and there were no statistically significant differences in prevalence among these 12 less-exposed islands. A prevalence of 2.45% was assumed for nonexposed populations, based on observed prevalence in the two most southern islands (Ebon and Mili), for the purpose of calculating ORs. A logistic regression model yielded a statistically significant effect of sex on OR for thyroid nodularity, with an OR 3.7 times higher in females. The model also yielded a significant trend for decreasing prevalence of thyroid nodularity with both distance and direction from the test site, with prevalence decreasing 3-fold per 100 miles (OR, 0.3 per 100 miles) from the site and 2-fold for every 10 degrees east or west of the site (OR, 0.59 per 10 degrees). The risk estimate for thyroid nodularity among the Marshall Islanders was 1,100 excess cases/Gy/year of exposure per 1 million people (0.0011/person-Gy/year, 0.000011/person-rad/year).

A large-scale screening program for thyroid disease was conducted in the Marshall Islands during the period 1993–1997 (Fujimori et al. 1996; Takahashi et al. 1997, 1999). Results of screening of 1,322 residents of Ebeye (in the Kwajalein Atoll, approximately 190 miles from Bikini Atoll) are reported in Takahashi et al. (1997). Evaluations included neck palpation, thyroid ultrasound, and fine needle aspiration biopsy if warranted (results on diagnoses relevant to thyroid cancer are discussed in

3. HEALTH EFFECTS

Section 3.2.1.7). The examiners were blind to the estimated thyroid radiation dose received by each subject. Among 815 subjects born before 1954, the date of the BRAVO test, 266 (32.6%) were diagnosed with thyroid nodules, 132 (16.2%) were palpable. The prevalence of thyroid nodules (palpable and detected by ultrasound) was higher in females than males; however, as was observed in the Hamilton et al. (1987) study, the difference was significant only for palpable nodules (palpable: females 17.7%, males 9.3%; total nodules: females 35.9%, males 21.0%). In either case, nodule prevalence was 2–3 times higher among groups born during the bomb testing period (before 1958) than after the testing ended. A logistic regression model applied to the nodule prevalence data revealed significant effects of sex, age, and distance from Bikini Atoll on nodule prevalence (Takahashi et al. 1997). A more recent report on the screening program described the results of thyroid palpation and ultrasound (7,721 subjects), tests of thyroid hormone (1,050 subjects), and iodine status (urinary iodide, 309 subjects) (Takahashi et al. 1999). The study group included 5,263 residents of Majuro (approximately 480 miles from Bikini Atoll), 1,610 residents from Ebeye Island (192 miles) and 348 residents from Mejit (398 miles). Of the 7,221 subjects examined in the study (1993–1997), 4,766 (66%) were of an age to have potential exposures to radioactive fallout from bomb tests. The prevalence of thyroid nodules (palpable and detected by ultrasound) was approximately 3 times higher in females than males; among females, the prevalence was highest (13%, 407 of 3,151) among women born before 1959, the date of the last bomb tests. Thyroid hormone tests (T_4 , T_3 , and TSH) revealed no evidence of an unusual prevalence of thyroid gland dysfunction. Measurements of urinary iodide levels suggested mild to severe iodine deficiency in the population; approximately 21% of the adult subjects had urinary iodides in the range of 22–45 nmol I/mmol creatinine (25–50 μg I/g creatinine). This corresponds to a urinary excretion rate and iodine intake rate of approximately 40–80 μg I/day (based on an assumed body weight of 60 kg). Thyroid volumes were compared in subjects who had nodules and were iodine deficient with subjects who were iodine sufficient and who did not have nodules. Although there was no apparent indication of excessive prevalence of thyroid enlargement in either the iodine-deficient or -sufficient groups, subjects who had the largest thyroid volumes tended to fall in the deficient-nodular group. Thyroid nodularity occurs in populations that have experienced prolonged iodine deficiency, although it is usually associated with goiter (Hermus and Huysmans 2000). The observation of a high prevalence of iodine deficiency in the Marshall Island population may be an important confounding variable in many of the epidemiology studies that have attempted to explore relationships between thyroid nodularity and radiation dose in the Marshall Island populations.

Chernobyl Accident. Subsequent to the release of radioactive materials from the Chernobyl power plant in 1986, an increased prevalence of thyroid nodules in children of the Belarus region was reported (Astakhova et al. 1996). An analysis of the results of ultrasound screening of 20,785 people in Belarus conducted during the period 1990–1995 revealed a prevalence of thyroid gland nodules that ranged from 4 to 22 per 1,000. Prevalence was highest (16–22 per 1,000) among residents from districts in which

3. HEALTH EFFECTS

thyroid radiation doses were estimated to have been above 1 Gy (1.3–1.6 Gy, 130–160 rad). Verified diagnoses from patients who were referred for further examination revealed a prevalence of thyroid cancer of 2.5–6.2 per 1,000, or approximately 13–50% of nodule cases, among cases from districts where thyroid radiation doses were estimated to have been above 1 Gy (1.3–1.6 Gy, 130–160 rad) (see Section 3.2.1.7 for further discussion of thyroid cancer related to the Chernobyl release). Nodular goiter was diagnosed in 5–22% of the thyroid nodule cases, and 7–64% of the nodule cases were diagnosed as benign cysts. In districts in which thyroid doses were estimated to have been <0.1 Gy, no thyroid cancers were diagnosed in the nodule cases; approximately 75–100% were diagnosed as cysts. Dietary iodine status was assessed from measurements of urinary iodine (Astakhova et al. 1996). Urinary iodide levels varied across regions in Belarus. Approximately 30–80% (mean 61%) of children and adolescents had overnight urinary iodine concentrations <100 µg/L, 10–50% (mean 26%) had concentrations <50 µg/L, and 0–25% (mean 9%) had concentrations <20 µg/L. These results suggest a substantial prevalence (on average 26 and 50% in some districts) of dietary iodine intakes below 50–70 µg/day (assuming a daily urine output of 1–1.4 L in children and adolescents). The results of other thyroid screening programs (e.g., the Chernobyl Sasakawa Health and Medical Cooperation Project) also suggest a high prevalence of goiter among people born in Belarus between the years 1976 and 1986, which would be consistent with a high prevalence of iodine deficiency in the population (UNSCEAR 2000). Therefore, iodine deficiency may have contributed to the observed thyroid nodularity and also a confounding variable in susceptibility to thyroid cancer (Gembicki et al. 1997).

Hanford Nuclear Site. The CDC (1999) has conducted a follow-up prevalence study of thyroid disease in populations who resided near the Hanford Nuclear Site in southeastern Washington during the period 1944–1957. As noted previously, at the time this profile was developed, a draft report of this study was available from the Fred Hutchinson Cancer Research Center web site (<http://www.fhcr.org/science/pbs/htds/>); however, a final published report was not available. The study included 3,441 subjects who were born during the period 1940–1946 in counties surrounding the Hanford Nuclear Site. Thyroid disease was assessed from a clinical evaluation of each subject, which included assessments of ultrasound or palpable thyroid nodules, thyroid hormone status, and thyroid autoimmunity and parathyroid hormone status. Historical information on thyroid disease and information on radiation exposures were obtained by interviews and, when possible, review of medical records of participants. Thyroid radiation doses were estimated using a dosimetry model developed in the Hanford Environmental Dose Reconstruction Project. Information on residence history and relevant food consumption patterns (e.g., milk consumption, breast feeding, consumption of locally harvested produce) for each study participant was obtained by interview. The estimated mean thyroid radiation dose, based in 3,190 participants, was 182 mGy (± 227 , SD) (18.2 ± 22.7 rad) and the range was 0.0008–2,842 mGy (0.00008–284 rad). An indication that the statistical power of the study was appreciably limited by the low distribution of thyroid doses is the fact that only 29 (0.8%) of the study population had estimated thyroid doses >1 Gy (100 rad)

3. HEALTH EFFECTS

and only 8 (0.3%) had doses >2 Gy. Doses varied geographically, with the highest doses received by people who lived near and downwind from the site. Health outcomes investigated included thyroid carcinoma, thyroid nodules, hypothyroidism, and hyperthyroidism (serum TSH levels), including Graves' disease, thyroid autoimmunity (serum antimicrosomal antibodies and antithyroid peroxidase), goiter, and hyperparathyroidism. Dose-response relationships were assessed using a linear regression model with adjustments for the following confounding and effect modifying variables: sex, age of first exposure, age of evaluation, ethnicity, smoking, and potential exposures from Nevada Test Site releases. Estimated dose coefficients were: thyroid carcinoma, not reported (linear model did not converge on maximum likelihood estimate); thyroid nodules, -0.014 ± 0.011 per Gy ($p=0.85$); hypothyroidism, 0.003 ± 0.02 per Gy ($p=0.4$); hyperthyroidism -0.008 ± 0.015 per Gy ($p=0.69$); thyroid autoimmunity, -0.007 ± 0.028 per Gy ($p=0.6$); goiter, not reported (linear model did not converge on maximum likelihood estimate); hyperparathyroidism, 0.000 ± 0.006 per Gy ($p=0.5$). Alternatives to the linear model including linear quadratic and logistic models were also explored. Incidence of thyroid disease was found to be unrelated to thyroid radioiodine dose for all outcomes evaluated.

Effects of Radioiodine on the Parathyroid Gland

Cases of hypo- and hyperparathyroidism have been reported in patients who received ^{131}I treatments for ablative therapy of thyroid cancer or hyperthyroidism. The parathyroid gland is in close proximity to the thyroid gland. Although in most people, the parathyroid and thyroid glands are separated by more than 1 cm, in approximately 20% of people, the parathyroid gland is located within the thyroid gland capsule (Glazebrook 1987). The latter configuration would result in irradiation of the parathyroid gland with β emission from ^{131}I concentrated in the thyroid gland; β emission from ^{131}I has a tissue penetration distance of approximately 0.5–2 mm (Esselstyn et al. 1982). Cases of parathyroid dysfunction have been reported after exposures to ^{131}I ranging from 4 to 30 mCi (0.15–1.1 GBq) (Better et al. 1969; Burch and Posillico 1983; Eipe et al. 1968; Esselstyn et al. 1982; Fjälling et al. 1983; Freeman et al. 1969; Glazebrook 1987; Jialal et al. 1980; Rosen et al. 1984). A clinical follow-up study evaluated serum calcium status of 125 patients (106 females, 19 males) who received ^{131}I for treatment of hyperthyroidism during the period 1951–1960. The follow-up assessments occurred 16–26 years (mean, 21 years) after exposure to ^{131}I (Fälling et al. 1983). A group of age- and sex-matched healthy subjects who had no history of irradiation to the head or neck region served as a control group. Exposures to ^{131}I ranged from 75 to 1,400 MBq (2–38 mCi). These corresponded to radiation doses to the parathyroid of 2–5 Gy in subjects whose parathyroid gland was 0.2 cm from the surface of the thyroid gland and 3–7.5 Gy in subjects whose parathyroid gland was at the surface of the thyroid gland. Two patients and two control subjects were found to have hypercalcemia and verified hyperparathyroidism (the exact basis for the verification was not reported). The ^{131}I exposures of the two patients were 140 and 450 MBq (3.8 and 12 mCi), respectively.

3. HEALTH EFFECTS

Hanford Nuclear Site. Hyperparathyroidism was assessed as part of the CDC (1999) study of health outcomes related to radioiodine releases from the Hanford Nuclear Site. The study included 3,441 subjects who were born during the period 1940–1946 in counties surrounding the site. Parathyroid hormone status was assessed from measurements of serum parathyroid hormone. Historical information on parathyroid disease was obtained by interviews and, when possible, review of medical records of participants. The estimated mean thyroid radiation dose, based on 3,190 participants, was 182 mGy (± 227 , SD) (18.2 ± 22.7 rad) and the range was 0.0008–2,842 mGy (0.00008–284 rad). Dose-response relationships were assessed using a linear regression model with adjustments for the following confounding and effect modifying variables: sex, age of first exposure, age of evaluation, ethnicity, smoking, and potential exposures from Nevada Test Site releases. Alternatives to the linear model including linear quadratic and logistic models were also explored. Incidence of hyperparathyroidism was found to be unrelated to thyroid radioiodine dose.

3.2.2.3 Immunological and Lymphoreticular Effects

Immunological and Lymphoreticular Effects of Stable Iodine

Information on immunological effects of oral exposure to iodine in humans relates to thyroid gland autoimmunity or immune reactions (e.g., iododerma). The highest NOAEL values and all reliable LOAEL values in each duration category for immunological and lymphoreticular effects from exposures by the oral route are presented in Table 3-1 and plotted in Figure 3-1.

Excess iodide intake may be contributing factor in the development of autoimmune thyroiditis in people who are susceptible (Brown and Bagchi 1992; Foley 1992; Rose et al. 1997; Safran et al. 1987). Autoimmune thyroiditis is an inflammation of the thyroid gland that can lead to fibrosis of the gland, follicular degeneration, follicular hyperplasia, and hypothyroidism (Weetman 2000). IgG autoantibodies to thyroglobulin and thyroid peroxidase are consistent features of the disorder. Iodine appears to play an important role in autoimmune response as human lymphocytes recognize and proliferate in response to iodinated human thyroglobulin, but not iodine-free thyroglobulin (Rose et al. 1997).

Evidence for iodide inducing autoimmune thyroiditis in humans is incomplete. Several studies have been conducted of people who reside in endemic goiter areas and who received iodide supplementation. In one study, otherwise healthy adults who had goiter, but no evidence of clinical hypothyroidism or hyperthyroidism or antithyroid antibodies, received either an oral placebo (16 females, 15 males) or 200 mg I/day (3 $\mu\text{g}/\text{kg}/\text{day}$ total intake) (16 females, 15 males) as potassium iodide for 12 months (Kahaly et al. 1997). Three subjects in the treatment group (9.7%, two females and one male) developed elevated levels of thyroglobulin and thyroid microsomal antibodies compared to none in the control

3. HEALTH EFFECTS

group. Two of these subjects developed hypothyroidism and one subject developed hyperthyroidism; all three subjects reverted to normal thyroid hormone status when the iodide supplementation was discontinued. In a similar study, 31 adult euthyroid patients from an endemic goiter region who had goiter received either 500 µg/day potassium iodide (382 mg I/day, 5.1 mg I/kg/day based on reported median body weight of 75 kg) for 6 months, and 31 patients received 0.125 mg T₄/day (Kahaly et al. 1998). Based on reported measurements of 24-hour urine iodide excretion, the preexisting iodide intake was approximately 40 µg/day (range, 13–77, 0.6 µg/kg/day); thus, the total intake during treatment was approximately 420 mg I/day (6 µg/kg/day). After 6 months of iodide supplementation, the mean 24-hour urinary iodide excretion rate was 415 µg/day, which is consistent with the estimate of a total iodide intake of approximately 420 µg/day. Six of the patients who received iodide (19%) developed high titres of thyroglobulin and thyroid microsomal antibodies, compared to none in the T₄ group. Four of the high antibody patients became hypothyroid and two patients became hyperthyroid. The thyroid hormone status reverted to normal and antibody titres decreased during a 6-month period following the treatment in which the patients received a placebo. A comparison of autoantibody titres of 27 adult patients who were diagnosed with iodide-induced goiter and/or hypothyroidism with 55 healthy adults revealed a significantly greater incidence of antibodies to thyroglobulin in the goiter patients (13 of 27, 48%) than in the healthy controls (9 of 55, 16%) (Hall et al. 1966). Iodide doses in the goiter group varied from 24 to 3,728 mg I/day (0.3–53 mg/kg/day). Koutras (1996) reported that 30% of a group of goiter patients developed thyroid autoimmunity several weeks after receiving 150 or 300 µg/day potassium iodide (115 or 130 µg I/day, 1.6–1.9 µg/kg/day); further details of the study were not provided.

Other studies have not found increases in autoimmunity associated with iodine supplementation. For example, thyroid status was compared in groups of children, ages 7–15 years, who resided in two areas of China where drinking water iodide concentrations were either 462 µg/L (n=120) or 54 µg/L (n=51) (Boyages et al. 1989; Li et al. 1987). Although the subjects were all euthyroid with normal values for serum thyroid hormones and TSH concentrations, TSH concentrations were significantly higher in the high iodine group. The high iodine group had a 65% prevalence of goiter and a 15% prevalence of Grade 2 goiter compared to 15% for goiter and 0% for Grade 2 goiter in the low iodine group. There were no differences in the serum titres of either thyroglobulin or thyroid peroxidase antibodies between the high and low iodine groups. Urinary iodine was 1,236 µg I/g creatinine in the high iodine group and 428 µg I/g creatinine in the low iodine group. Assuming a body weight of 40 kg and lean body mass of 85% of body weight, the above urinary iodine/creatinine ratios are approximately equivalent to iodine excretion rates, or steady state ingestion rates of 1,150 µg/day (29 µg/kg/day) and 400 µg/day (10 µg/kg/day) in the high and low iodide groups, respectively.

The effects of iodide on the development of autoimmune thyroiditis has been examined in animal models. In general, iodine does not induce autoimmune thyroiditis in outbred strains of rats; however, a

3. HEALTH EFFECTS

susceptible inbred strain, the BB/Wor rat, has a high incidence of spontaneous autoimmune thyroiditis and does respond to iodide with an increased incidence of thyroid autoimmunity (Allen et al. 1986). This can be detected histologically as a lymphocytic infiltration of the gland (lymphocytic thyroiditis) accompanied by increased serum titres of antibodies to thyroglobulin, and increased serum TSH concentrations, indicating thyroid gland suppression (Allen and Braverman 1990). Weanling BB/Wor rats that were exposed to 0.05% iodide in drinking water for 8 weeks (approximately 85 mg/kg/day) had a significantly higher incidence of lymphocytic thyroiditis (27 of 35, 77%) compared to a control group (11 of 36, 30%) that received tap water. Similarly exposed outbred strains did not have an increase in lymphocytic thyroiditis. The spontaneous incidence of lymphocytic thyroiditis in the Buffalo strain rat (a Sprague-Dawley strain) is increased after neonatal thymectomy (Noble et al. 1976). In thymectomized Buffalo rats, 12 weeks of exposure to 0.05% iodide in drinking water (approximately 70 mg/kg/day) resulted in a significant increase in the incidence of lymphocytic thyroiditis (73%) compared to a control group that received tap water (31%) (Allen and Braverman 1990). The treatment group also had significantly higher serum TSH concentrations and significantly higher serum titres of antithyroglobulin antibody. In both of the above two studies, intake from food (Purina chow) was approximately 0.05 mg/kg/day.

Oral exposure to excess iodide can produce allergic reactions in sensitive subjects. The reactions include urticaria, acneiform skin lesions, and fevers (Kurtz and Aber 1982; Rosenberg et al. 1972; Stone 1985). There were also cases of more serious reactions involving angioedema (localized edema), vasculitis, peritonitis and pneumonitis, and complement activation (Curd et al. 1979; Eeckhout et al. 1987). Both humoral and cell-mediated immune response are thought to be involved (Curd et al. 1979; Rosenberg et al. 1972; Stone 1985). In general, reactions to iodide have occurred in association with repeated doses exceeding 300 mg I/day.

Oral exposure to excess iodide can produce skin lesions, referred to as ioderma, which are thought to be a form of cell-mediated hypersensitivity (Rosenberg et al. 1972; Stone 1985). The dermal lesions appear to be unrelated to thyroid gland function. Characteristic symptoms include acneiform pustules, which can coalesce to form vegetative nodular lesions on the face, extremities, trunk, and mucous membranes. The lesions regress and heal when the excess iodide intake is discontinued. The clinical literature includes cases of ioderma that occurred subsequent to oral doses of iodide 300–1,000 mg I/day (5–14 mg/kg/day) (Baumgartner 1976; Khan et al. 1973; Kincaid et al. 1981; Kint and Van Herpe 1977; Peña-Penabad et al. 1993; Rosenberg et al. 1972; Shelly 1967; Soria et al. 1990). However, in many of these cases, preexisting disease and related drug therapy may have contributed to the reaction to the iodine; thus, the dose-response relationship for ioderma in healthy people remains highly uncertain. A typical regimen in the case literature was potassium iodide co-administered with theophylline and phenobarbital for treatment of obstructive lung disease. In at least two cases, transient dermal lesions typical of ioderma

3. HEALTH EFFECTS

were elicited by a single oral dose of 360 or 500 mg iodide (5.1 or 7.1 mg/kg/day), as potassium iodide and similar lesions were induced in these same patients by oral doses of aspirin, suggesting a possible cross sensitivity (Shelly 1967). In a more typical case, an adult male developed vegetative dermal lesions of the face, scalp, and trunk 5 days after receiving approximately 300 mg I/day (5.1 mg/kg/day) as potassium iodide (390 mg/day), along with penicillin for an acute respiratory tract infection (Soria et al. 1990). The lesions healed within 4 weeks after the potassium iodide was discontinued. Another adult male developed a vegetative dermal lesion of the neck and trunk after receiving approximately 600 mg I/day (10 mg/kg/day) as potassium iodide (720 mg/day) along with theophylline for obstructive pulmonary disease for 8 months (Soria et al. 1990). The lesions regressed within 3 weeks after the potassium iodide was discontinued and returned when an oral provocation dose of potassium iodide was administered. Another case of ioderma occurred in an adult female who received oral doses of approximately 740 mg I/day (11 mg/kg/day) as potassium iodide (970 mg/day) for 6 months, as part of a treatment for obstructive lung disease (Kincaid et al. 1981). Other drugs included in the patient's treatment were ephedrine, theophylline, and phenobarbital. The lesions occurred on the face and conjunctiva of the eye, and healed several weeks after the potassium iodide was discontinued. A similar case occurred in an adult woman, similarly treated for 1 year with 990 mg I/day (14 mg/kg/day) as potassium iodide (1,300 mg/day) for asthma (along with ephedrine, theophylline, and phenobarbital) (Rosenberg et al. 1972). The vegetative lesions occurred on her face and arms and healed within 3 weeks after the potassium iodide was discontinued. In a more complex case, an adult female who was being treated for a variety of disorders, including polyarteritis nodosa, for which she was receiving cyclophosphamide and prednisone, and pneumonia, for which she was receiving an expectorant containing potassium iodide, developed vegetating dermal lesions on her face (Soria et al. 1990). The lesions healed within 1 month after the iodide expectorant was discontinued. She received vidarabine during this period, as the dermal lesions were, at that time, suspected of being a herpes simplex infection. One week after receiving approximately 400 mg I/day (6 mg/kg/day) as potassium iodide (520 mg/day), similar lesions of the skin and oral mucosa developed. The lesions healed within 3 weeks after the potassium iodide was discontinued.

Oral exposures to iodide can induce fevers that are thought to have an immunological basis. The fevers do not appear to be related to thyroid function. Reported clinical cases have almost always involved a preexisting disease, usually pneumonia or obstructive lung disease in which potassium iodide was administered along with other drugs, including antibiotics, barbiturates, and methylxanthines; thus, the dose-response relationship for healthy people is highly uncertain. In one case, recurrent fevers occurred in an adult male who was receiving oral doses of approximately 1,080 mg I/day (15 mg/kg/day) as a potassium iodide solution (assumed, but not specified in the case report, to be a saturated solution) for approximately 15 years (Kurtz and Aber 1982). The fevers stopped within 2 weeks after the potassium iodide was discontinued. In another case, an adult male developed a fever 8 days after the start of a daily

3. HEALTH EFFECTS

regimen of approximately 1,440 mg I/day as a saturated solution of potassium iodide for treatment of a respiratory illness; the fever stopped within 3 days after the potassium iodide was discontinued (Horn and Kabins 1972). In another case, an adult female developed a fever after a dosage of approximately 1,620 mg I/day (23 mg/kg/day) as a saturated potassium iodide solution along with ampicillin to treat pneumonia (Horn and Kabins 1972). The fever stopped within 36 hours after the potassium iodide was discontinued; at the same time, a regimen of diazepam, secobarbital, and glycerol guaiacolate was administered. The fever returned when a challenge dose of potassium iodide was administered. A fourth case involved an adult female diabetic patient who received 1,080 mg I/day (15 mg/kg/day) as a saturated potassium iodide solution along with antibiotics, cortisone, and aminophylline for pneumonia (Horn and Kabins 1972). Four days after the potassium iodide treatments began, the patient developed a fever, which stopped when the potassium iodide was discontinued.

Cases of autoimmune hyperthyroidism after exposures to ^{131}I for ablative treatment of hyperthyroidism have been reported. In three cases, thyrotoxicosis developed with serum antibodies to TSH receptor developed 3–6 months after the patients received oral treatments with 40–86 mCi ^{131}I (1.5–3.2 GBq) for reduction of nontoxic goiter that was compressing the trachea (Huysmans et al. 1997a). Prior to the ^{131}I treatments, the patients were euthyroid and had no detectable TSH antibodies.

Immunological and Lymphoreticular Effects of Radioiodine

Marshall Islands. Large scale assessments of thyroid autoimmunity have been conducted in the Marshall Islands, where exposures to ^{131}I occurred as a result of fallout and contamination from test detonations of nuclear bombs during the period 1946–1958 (see Section 3.2.1.2, Endocrine, for a more complete description of these studies). In a thyroid screening program conducted during the period 1993–1997, 7,721 subjects were evaluated for various end points of thyroid size, nodularity, and function (Fujimori et al. 1996, Takahashi et al. 1997, 1999). Antithyroglobulin antibodies in serum were detected in 67 of 2,700 (2.5%) subjects examined (Fujimori et al. 1996). This prevalence is unremarkable compared to that found in other populations, (10% in healthy adults, Marcocci and Chiovata 2000; Takahashi et al. 1999).

Chernobyl Accident. A study that compared thyroid cancers in Belarus and Ukraine diagnosed after the Chernobyl releases with those diagnosed in Italy and France during the same time period found that the Belarus-Ukraine cases had a higher incidence of thyroid autoimmunity (i.e., elevated antithyroid peroxidase and thyroglobulin antibodies) than the Italy-France cases (Pacini et al. 1997). It is unclear to what extent the autoimmunity may be related to the exposures to radioiodine. Serum antithyroglobulin antibody titres were measured in 53 children ages 7–14 years (in 1993–1994) who received 0.4–3.2 Gy (40–320 rad) as a result of the Chernobyl release (Chernyshov et al. 1998). Antibody titres were detected in 80.6% of exposed children compared to 16.7% of a reference group that had no estimated exposure to

3. HEALTH EFFECTS

^{131}I , and there was a significant positive correlation between antibody titre and estimated thyroid ^{131}I dose. These results suggest a possible contribution of thyroid radioiodine exposure to thyroid autoimmunity. Other screening programs conducted in Belarus have not found relationships between thyroid autoimmunity and radiation exposure, as assessed by ^{137}Cs soil levels or body ^{137}Cs levels (UNSCEAR 2000).

Hanford Nuclear Site. Thyroid autoimmunity was assessed as part of the CDC (1999) study of health outcomes related to radioiodine releases from the Hanford Nuclear Site. The study included 3,441 subjects who were born during the period 1940–1946 in counties surrounding the site. Thyroid autoimmunity was assessed from measurements of serum antimicrosomal antibody and antithyroid peroxidase. Historical information on thyroid disease, including autoimmunity and related disorders (e.g., Graves' disease), was obtained by interviews and, when possible, review of medical records of participants. The estimated mean thyroid radiation dose, based on 3,190 participants, was 182 mGy (± 227 , SD) (18.2 ± 22.7 rad) and the range was 0.0008–2,842 mGy (0.00008–284 rad). Dose-response relationships were assessed using a linear regression model with adjustments for the following confounding and effect modifying variables: sex, age of first exposure, age of evaluation, ethnicity, smoking, and potential exposures from Nevada Test Site releases. Alternatives to the linear model including linear quadratic and logistic models were also explored. Incidence of thyroid autoimmunity was found to be unrelated to thyroid radioiodine dose.

3.2.2.4 Neurological Effects

Exposure to excess iodine has been shown to produce subclinical hypothyroidism, which in certain sensitive individuals, may take the form of hypothyroidism. Sensitive populations include fetuses, newborn infants, and individuals who have thyroiditis or Graves' disease, many of whom have abnormal autoimmune disorders (see Section 3.2.2.2, Endocrine Effects). Of these iodine-induced forms of hypothyroidism, that occurring in the fetus or newborn infant has the greatest potential for producing neurological effects. This is because thyroid hormones are essential to the development of the neuromuscular system and brain. An iodine-induced hypothyroid state can result in delayed or deficient brain and neuromuscular development of the newborn (Boyages 2000b). Iodine-induced hypothyroidism in an older child or adult would be expected to have little or no deleterious effects on the neuromuscular system. Exposure of a fetus to large amounts of radioiodine would result in thyroid tissue ablation and in similar delayed brain and neuromuscular development, if the hypothyroid state was not corrected (e.g., with hormone replacement therapy) after birth. An example is a case of severe hypothyroidism with neurological sequelae that developed at age 8 months in an infant whose mother received 99 mCi (3.7 GBq) of ^{131}I during her sixth week of pregnancy (Goh 1981).

3. HEALTH EFFECTS

Exposure to excess iodine can also produce hyperthyroidism in sensitive individuals (see Section 3.2.2.2, Endocrine Effects). These include people who are initially iodine deficient, those who have thyroid disease, including Graves' disease, who have been treated with antithyroid drugs, people who have had postpartum thyroiditis, and those who have developed thyrotoxicosis from amiodarone or interferon-alpha treatments (Roti and Uberti 2001). Patients who develop thyrotoxicosis may experience neuromuscular disorders, including myopathy, periodic paralysis, myasthenia gravis, peripheral neuropathy, tremor, and chorea (Boyages 2000a)

3.2.2.5 Reproductive Effects

Reproductive Effects of Stable Iodine

Oral exposure to excess iodine may produce hypothyroidism or hyperthyroidism (see Section 3.2.2.2, Endocrine Effects) and may cause disruption of reproductive function secondary to thyroid gland dysfunction. Hypothyroidism can produce changes in the menstrual cycle in humans, including menorrhagia (excessive uterine bleeding) and anovulation (no ovulation). Abortions, stillbirths, and premature births have also been associated with hypothyroidism (Loncope 2000a). Reproductive impairments associated with hyperthyroidism include amenorrhea, and alterations in gonadotropin release, sex hormone-binding globulin (SHBG), and associated changes in the levels and metabolism of steroid hormones in both females and males (Longcope 2000b).

A clinical study of the outcomes of 70 pregnancies in patients who received ^{131}I for ablative treatment of thyroid cancer 2–10 years (mean, 5.3 years) prior to pregnancy revealed only two spontaneous abortions (Casara et al. 1993). The maternal ^{131}I exposures ranged from 1.85 to 16.55 GBq (50–400 mCi); the mean exposure was 4.40 GBq (120 mCi). Maternal gonadal radiation doses ranged from 11 to 20 cGy (11–20 rad). In a similar study, 37 patients who received ^{131}I prior to conception (mean, 16.5 months prior to conception; range 1–60 months); exposures ranged from 1.1 to 13.1 GBq (30–350 mCi) with a mean exposure of 3.67 GBq (100 mCi) (Lin et al. 1998); of 58 pregnancies reported, there were 8 spontaneous abortions and 2 threatened abortions. In a retrospective review of pregnancy outcomes of 154 women who received ablative ^{131}I therapy for thyroid cancer, two cases of infertility occurred in 35 patients who attempted to conceive (Smith et al. 1994). The ^{131}I exposure range was 77–250 mCi (2.8–9.2 GBq) with a mean exposure of 148 mCi (5.5 GBq). The above studies did not have control comparison groups.

Clinical cases of impaired testicular function have been reported following oral exposures to ^{131}I for ablative treatment of thyroid cancer (Ahmed and Shalet 1985; Handelsman and Turtle 1983; Pacini et al. 1994). Effects observed included low sperm counts, azospermia (absence of spermatozoa), and elevated

3. HEALTH EFFECTS

serum concentrations of follicle stimulating hormone (FSH), which persisted for more than 2 years of follow-up. Exposures to radioiodine ranged from 50 to 540 mCi (1.8–20 GBq). A study of 103 patients who received ¹³¹I treatments for thyroid cancer found low sperm counts and elevated serum FSH concentrations when patients were examined 10–243 months after treatment (mean, 94 months) (Pacini et al. 1994). Exposures to radioiodine ranged from 30 to 1,335 mCi (1.1–49.5 GBq) with a mean exposure of 167 mCi (6.2 GBq).

Reproductive Effects of Radioactive Iodine

A large-scale retrospective analysis was conducted to evaluate pregnancy health and reproductive outcomes of women who were exposed to radiation resulting from releases from the Chernobyl nuclear power plant, including a major contribution from ¹³¹I (Petrova et al. 1997). Interpretation of the results of this study, in terms of the contribution of radioiodine to the outcomes, is highly uncertain, as other factors could have affected the outcomes, including exposure to other forms of radiation, nutrition, or other chemical exposures. Nevertheless, because it is one of the only large-scale epidemiological studies that has focused on reproductive and developmental outcomes, and because of the substantial contribution that radioiodine made to radiation exposures after the Chernobyl releases, a brief description of the study is presented here. In the retrospective analysis, clinical records on 755,297 pregnancies that occurred in Belarus during the period 1982–1990 were evaluated. Approximately half of the women resided in Gomel and Mogilev, two districts that were relatively heavily contaminated with radioiodine and other radionuclides, and approximately half of the women lived in two relatively lightly contaminated areas, Brest and Vitebsk. Three categories of outcomes were evaluated: pregnancy outcome, including stillbirths, low birth weight, and neonatal or postneonatal mortality; maternal morbidity; and infant health, including intrauterine hypoxia, perinatal infection, respiratory disorders, and congenital anomalies. Annual incidence of maternal anemia, renal insufficiency (elevated serum BUN and creatinine), and toxemia appeared to increase more sharply in the heavily contaminated districts after 1986, the year of the Chernobyl releases (a statistical analysis of trend was not reported). Incidence of congenital abnormalities and neonatal respiratory disorders also appeared to increase more sharply in the heavily contaminated districts after 1986 (no statistical analysis of trend was reported). Fetal death rates appeared to increase or not decline in contaminated districts to the same extent as in less contaminated districts.

A cohort study was conducted as part of this retrospective analysis (Petrova et al. 1997). Health records on 757 infants and their mothers who resided in radiation-contaminated or relatively uncontaminated areas of Belarus were analyzed. The prevalence of maternal toxemia was 4–5 times greater among women who resided in contaminated areas (25–30%) compared to women from the control areas. The prevalence of atopic dermatitis in infants who resided in contaminated areas was approximately 2 times

3. HEALTH EFFECTS

higher (approximately 40%) compared to infants from control areas. The prevalence of anemia (low blood hemoglobin levels) was 6–7 times higher in infants from contaminated areas (18–20%).

Conclusions regarding relationships between pregnancy outcomes and exposure to radioiodine cannot be drawn from the results of these studies. A controlled epidemiological design (e.g., case-control) would be needed to further explore whether such a relationship might exist.

The highest NOAEL values and all reliable LOAEL values in each duration category for reproductive effects from exposures by the oral route are presented in Table 3-1 and plotted in Figure 3-1.

3.2.2.6 Developmental Effects

Exposure to excess iodine may produce hypothyroidism and hyperthyroidism (see Section 3.2.2.2, Endocrine Effects), which could give rise to developmental defects secondary to thyroid gland dysfunction (Boyages 2000a, 2000b). Hypothyroidism may be associated with impairment in neurological development of the fetus or growth retardation (Boyages 2000a, 2000b; Snyder 2000a). Martin and Rento (1962) reported two cases of goiter and severe transient hypothyroidism, without neurological sequelae in infants born to mothers who ingested potassium iodide during pregnancy; the approximate dosages were 920 and 1,530 mg I/day (13 and 22 mg/kg/day). Growth acceleration may occur in childhood hyperthyroidism, which is thought to be related to accelerated pituitary growth hormone turnover or a direct effect of thyroid hormone on bone maturation and growth (Snyder 2000b).

A clinical study of the outcomes of 70 pregnancies in patients who received ¹³¹I for ablative treatment of thyroid cancer 2–10 years (mean, 5.3 years) prior to pregnancy revealed only two spontaneous abortions (Casara et al. 1993). Of 73 infants born to the patients, one was diagnosed with tetralogy of Fallot's (pulmonic stenosis, atrial septal defect, and right ventricular hypertrophy) and the two other infants had low birth weights with subsequent normal growth rates. The maternal ¹³¹I exposures ranged from 1.85 to 16.55 GBq (50–400 mCi); the mean exposure was 4.40 GBq (120 mCi). Maternal gonadal radiation doses ranged from 11 to 20 cGy (11–20 rad). A similar study was reported of 37 patients who received ¹³¹I 1–60 months prior to conception (mean, 16.5 months); exposures ranged from 1.1 to 13.1 GBq (30–350 mCi) with a mean exposure to 3.67 GBq (100 mCi) (Lin et al. 1998); of 58 pregnancies reported, there were 8 spontaneous abortions and 2 threatened abortions. Birth weights of newborns of women who received ¹³¹I were not different from newborns of maternal age-matched controls who did not receive ¹³¹I and who were not thyroid cancer patients. A retrospective review of pregnancy outcomes of women who received ablative ¹³¹I therapy for thyroid cancer found 3 spontaneous abortions and 4 premature deliveries out of 67 pregnancies in 32 patients (Smith et al. 1994). Two infants were born within 1 year of the maternal ¹³¹I therapy and both died of congenital abnormalities; severe hypoparathyroidism and

3. HEALTH EFFECTS

hypothyroidism in one case, and Down's syndrome and cardiac anomalies in the second case. The ^{131}I exposure range was 77–250 mCi (2.8–9.2 GBq) with a mean exposure of 148 mCi (5.5 GBq). Goh (1981) reported a case of cretinism that developed at age 8 months in an infant whose mother received 99 mCi (3.7 GBq) of ^{131}I during her sixth week of pregnancy.

One epidemiological study has examined health outcomes of infants of mothers who resided in the Belarus region before or after the Chernobyl accident (Petrova et al. 1997). Interpretation of the results of this study, in terms of the contribution of radioiodine to the outcomes, is highly uncertain, as other factors could have affected the outcomes, including exposure to other forms of radiation, nutrition, or other chemical exposures. Nevertheless, because it is the only epidemiological study that has focused on reproductive and developmental outcomes, and because of the substantial contribution that radioiodine made to radiation exposures after the Chernobyl releases, a brief description of the study is presented here. As part of a retrospective cohort study, health records were analyzed on 757 infants and their mothers who resided in heavily radiation-contaminated areas of Belarus resulting from radionuclide releases from the Chernobyl nuclear power plant or relatively uncontaminated areas (Petrova et al. 1997). Prevalence of atopic dermatitis in infants who resided in contaminated areas was approximately 2 times higher (approximately 40%) compared to infants from control areas. The prevalence of anemia (low blood hemoglobin levels) was 6–7 times higher in infants from contaminated areas (18–20%). Interpretation of the results of this study, in terms of the contribution of radioiodine, to the outcomes, is highly uncertain, as other factors could have affected the outcomes, including exposure to other forms of radiation, nutrition, or other chemical exposures.

The highest NOAEL values and all reliable LOAEL values in each duration category for developmental effects from exposures by the oral route are presented in Table 3-1 and plotted in Figure 3-1.

3.2.2.7 Cancer

Cancer effect levels (CELs) for iodine exposures by the oral route are presented in Table 3-2 and plotted in Figure 3-2.

Stable Iodine and Cancer

The relationship between iodide intake and thyroid cancer has been examined in several large-scale epidemiology studies. The results of these studies suggest that increased iodide intake may be a risk factor for thyroid cancer in certain populations, in particular, populations residing in iodine deficient, endemic goiter regions (Franceschi 1998; Franceschi and Dal Maso 1999). Not all studies have found increased risk of cancer; however, a recurrent observation is an apparent shift in the histopathology

Table 3-2. Levels of Significant Exposure to Iodine - Radiation Toxicity - Oral

Key to ^a figure	Species (Strain)	Exposure/ duration/ frequency (Specific route)	System	NOAEL (rad)	LOAEL		Reference Chemical Form
					Less serious (rad)	Serious (rad)	
ACUTE EXPOSURE							
Systemic							
1	Human		Endocr			145 (thyroid gland nodularity)	Astakhova et al. 1996 131 I
2	Human		Endocr			325 (thyroid gland nodularity)	Conard 1984 131 I
3	Human		Endocr			2000 (thyroid gland nodularity)	Hamilton et al. 1987 131 I
Immunological/Lymphoreticular							
4	Human					180 (thyroid gland nodularity)	Pacini et al. 1997 131 I
Cancer							
5	Human					30 (thyroid cancer)	Astakhova et al. 1998 131 I
6	Human					30 (thyroid cancer)	Drobyshevskaya et al. 1996 131 I
7	Human	(F)				5 (kidney and liver cancer)	Holm et al. 1991 131 I
8	Human	(F)				6000 (thyroid cancer)	Ron et al. 1998 131 I
9	Human					20 (thyroid cancer)	Tronko et al. 1996 131 I

Table 3-2. Levels of Significant Exposure to Iodine - Radiation Toxicity - Oral (continued)

Key to figure ^a	Species (Strain)	Exposure/ duration/ frequency (Specific route)	System	NOAEL (rad)	LOAEL		Reference Chemical Form
					Less serious (rad)	Serious (rad)	
CHRONIC EXPOSURE							
Systemic							
10	Human	(F)	Endocr	18			CDC 1999 131 I
Cancer							
11	Human	(F)				9 (thyroid neoplasm)	Gilbert et al. 1998 131 I
12	Human	(F)				325 (thyroid neoplasm)	Kerber et al. 1993 131 I
13	Human	(F)				25 (thyroid neoplasm)	Rallison 1996 131 I

^aThe number corresponds to entries in Figure 3-2.

Endocr = endocrine; (F) = feed; LOAEL = lowest-observed-adverse-effect level; NOAEL = no-observed-adverse-effect level

Figure 3-2. Levels of Significant Exposure to Iodine - Radiation Toxicity - Oral
Acute (≤ 14 days)

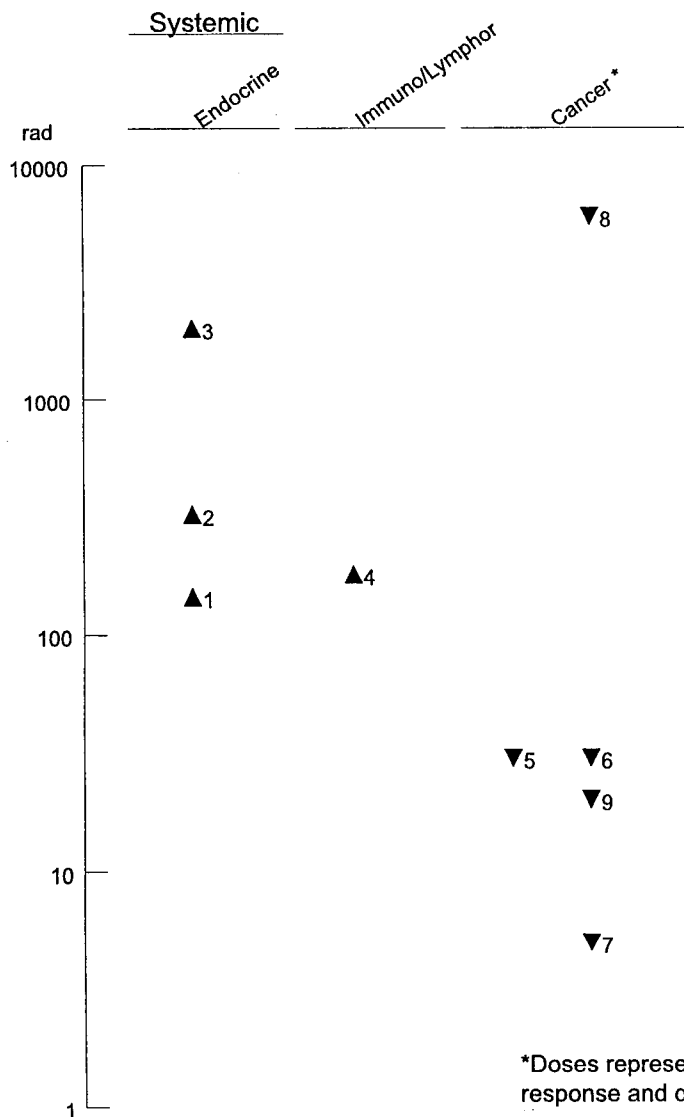

c-Cat	-Humans	f-Ferret	n-Mink	◆ Cancer Effect Level-Animals	▼ Cancer Effect Level-Humans	■ LD50/LC50
d-Dog	k-Monkey	j-Pigeon	o-Other	● LOAEL, More Serious-Animals	▲ LOAEL, More Serious-Humans	⋮ Minimal Risk Level
r-Rat	m-Mouse	e-Gerbil		○ LOAEL, Less Serious-Animals	△ LOAEL, Less Serious-Humans	⋮ for effects
p-Pig	h-Rabbit	s-Hamster		○ NOAEL - Animals	△ NOAEL - Humans	⋮ other than
q-Cow	a-Sheep	g-Guinea Pig				⋮ Cancer

Figure 3-2. Levels of Significant Exposure to Iodine - Radiation Toxicity - Oral (continued)

Chronic (≥ 365 days)

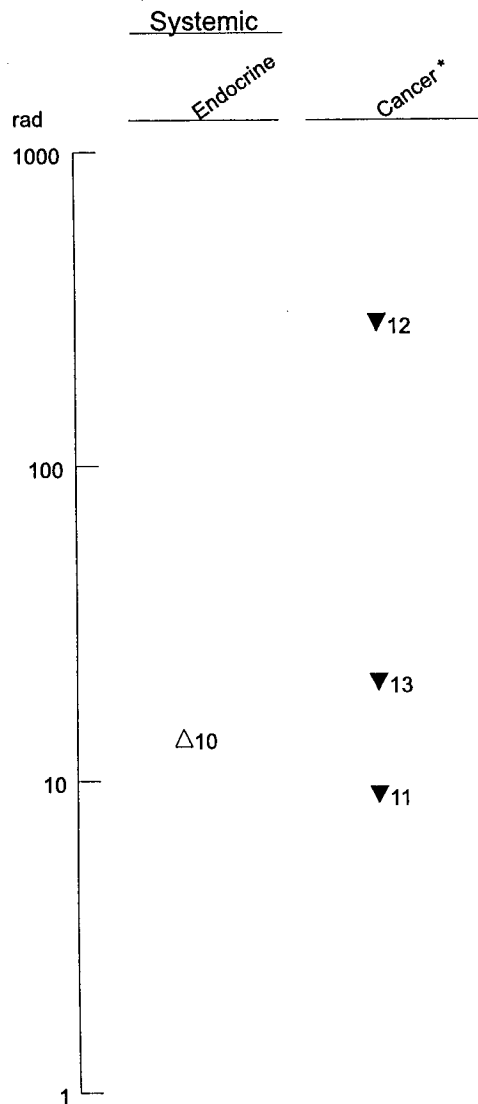

*Doses represent the lowest dose tested per study that produced a tumorigenic response and do not imply the existence of a threshold for the cancer end point.

c-Cat	-Humans	f-Ferret	n-Mink	◆ Cancer Effect Level-Animals	▼ Cancer Effect Level-Humans	■ LD50/LC50
d-Dog	k-Monkey	j-Pigeon	o-Other	● LOAEL, More Serious-Animals	▲ LOAEL, More Serious-Humans	Minimal Risk Level
r-Rat	m-Mouse	e-Gerbil		○ LOAEL, Less Serious-Animals	△ LOAEL, Less Serious-Humans	for effects
p-Pig	h-Rabbit	s-Hamster		○ NOAEL - Animals	△ NOAEL - Humans	other than
q-Cow	a-Sheep	g-Guinea Pig				Cancer

DRAFT FOR PUBLIC COMMENT

3. HEALTH EFFECTS

towards a higher prevalence of papillary cancers, relative to follicular cancers, after increased iodine intake in otherwise iodine-deficient populations (Bakiri et al. 1998; Belfiore et al. 1987; Kolonel et al. 1990; Pettersson et al. 1991, 1996). Two studies found a significant excess of thyroid gland cancer in populations from endemic goiter regions whose diets were supplemented to achieve approximate iodine intakes of 3.5 µg/kg/day (Bacher-Stier et al. 1997; Harach and Williams 1995).

A case control study of residents of Hawaii examined dietary habits, including iodine intake and other variables in 191 cases of thyroid cancer and 441 age- and sex-matched controls, diagnosed during the period 1980–1987 (Kolonel et al. 1990). Female cases had significantly higher dietary iodine intakes than controls, although the group mean differences were not substantial; cases, 394 µg I/day (5.6 µg/kg/day); controls, 326 µg I/day (4.7 µg/kg/day). When cases and controls were classified according to dietary iodine intake (quartile), the ORs for thyroid cancer in females increased with increasing iodine intake; however, ORs were not statistically significant and there were no significant trends in the OR with increasing iodine intake. Other variables for which ORs were statistically significant included miscarriage (2.4), use of fertility drugs (4.2), and the combination of either of the former characteristics with an iodine intake exceeding 300 µg I/day or 4.3 µg/kg/day (4.8 or 7.3, respectively), or seafood intake exceeding 27 g/day (3.0 or 6.9, respectively).

A cohort study compared thyroid cancer rates in iodine sufficient and iodine deficient regions of Sweden during the period 1958–1981 (Pettersson et al. 1991, 1996). Iodine deficient regions were defined as having had a goiter prevalence that was >33% in females and >15% in males, based on a 1930 survey. In Sweden, dietary iodine intake has increased over the study period as a result of dietary supplementation, which began in 1936 and was subsequently increased in 1966 and 1971 (Pettersson et al. 1996). Thus, iodine deficiency, even in the previously deficient regions has diminished. A multivariate model that included sex, age, dates of diagnosis, and region (i.e., iodine deficient or sufficient) as variables was applied to a sample of 5,838 thyroid cancer cases to estimate adjusted RR for thyroid cancer, where RR was the ratio of the adjusted cancer incidence rates for iodine deficient:iodine sufficient regions. The RR for papillary thyroid cancer was 0.8 (95% CI, 0.73–0.88), suggesting lower risk in the iodine deficient regions, relative to the iodine sufficient regions. The RR for follicular thyroid cancer was 1.98 (1.60–2.4) in males and 1.17 (1.04–1.32) in females, suggesting a 1.2- to 2-fold higher risk for follicular cancer in populations living in the iodine deficient regions, relative to iodine sufficient regions. Analysis of incidence of thyroid cancer as a function of dates of diagnosis revealed a significant trend for increasing follicular cancers in the iodine deficient areas, but not in the iodine sufficient areas. A significant trend for increasing papillary cancers was evident in both the iodine sufficient and deficient regions.

A cohort study examined the prevalence of thyroid cancer during the period 1979–1985 in populations living in iodine deficient and sufficient areas of Sicily (Belfiore et al. 1987). Mean urinary iodine

3. HEALTH EFFECTS

excretion rate in the deficient regions was approximately 19–43 µg I/day (0.3–0.6 µg/kg/day) and, in the iodine sufficient regions, was approximately 114 µg I/day (1.6 µg/kg/day); the intakes in the two regions would be expected to be similar to urinary excretion rates. Randomly selected subjects from both regions were subjected to radioiodine thyroid scans to determine the presence of cold thyroid gland nodules, indicative of a possible tumor with suppressed iodine uptake. The prevalence of cold nodules in the iodine deficient region was significantly greater (72 of 1,683, 4.3%) than in the control group (21 of 1,253, 1.7%). In the second phase of this study, all patients who had cold nodules in the two study areas, 911 patients from the iodine-deficient region, and 2,537 patients from the iodine-sufficient region, were biopsied. The prevalence of thyroid cancer among patients who had one or more cold nodules was higher in the iodine sufficient region (5.48%) than in the deficient region (2.96%). The prevalence of papillary tumors, relative to that of follicular tumors, was higher in the iodine sufficient region (3.8) than in the deficient region (1.0). When the thyroid cancer prevalence among patients with cold nodules was adjusted for the estimated prevalence of cold nodules in the two regions, the estimated prevalence of thyroid cancer in the iodine deficient region was significantly higher (127 in 100,000) than in the sufficient region (93 in 100,000).

Epidemiological studies suggest that the incidence of thyroid cancer may increase in endemic goiter regions after supplementation of the diet with iodine. In Austria, iodized salt was introduced into the diet in 1963 and then increased further in 1991. The mean urinary iodide concentration before the adjustment was 42–78 µgI/g creatinine and after the adjustment was 120–140 µgI/g creatinine; these are approximately equivalent to 77–146 µg/day (1–2 µg/kg/day) and 225–263 µg/day (3–4 µg/kg/day), respectively (Bacher-Stier et al. 1997; Mostbeck et al. 1998). A retrospective analysis of medical records in the Tyrol region of Austria (1,063,395 inhabitants) concluded that the incidence of thyroid cancer increased from 3.1 per 100,000 year for the period 1960–1970 to 7.8 for the period 1990–1994 (Bacher-Stier et al. 1997). The prevalence of papillary tumors appeared to increase relative to that of follicular tumors after supplementation; the ratio of papillary:follicular tumors was 0.6 before supplementation and 1.5 after supplementation. Improved diagnosis may have contributed to the increased incidence. In support of this, a trend was observed towards increased prevalence of less advanced tumor stages in 439 patients for which complete medical records were available. The authors reported that “no excessive natural radiation has been found in Tyrol”.

A retrospective analysis of 1,000 consecutive patient records from endocrine wards in Algiers, recorded during the period 1967–1991, revealed significantly greater prevalence of differentiated follicular thyroid tumors in patients who resided in an endemic goiter region (53.6%; n=581) than in nonendemic regions (44.0%; n=236) (Bakiri et al. 1998). The prevalence of follicular tumors was significantly greater than that of papillary tumors in the endemic areas, whereas follicular tumors were less prevalent than papillary tumors in the nonendemic region. The ratio of papillary:follicular tumors was 1.2 in the endemic region

3. HEALTH EFFECTS

and 0.8 in the nonendemic region. The mean urinary iodide concentration in the goiter endemic area was $<50 \mu\text{g I/g creatinine}$ and was $>80 \mu\text{g I/g creatinine}$ in the nonendemic region; these are approximately equivalent to $<95 \mu\text{g/day}$ ($1.2 \mu\text{g/kg/day}$) and $>150 \mu\text{g/day}$ ($2.1 \mu\text{g/kg/day}$), respectively.

A retrospective analysis of 144 cases of thyroid cancer in the Salta region of Argentina, diagnosed during the period 1960–1980, found that the prevalence of papillary tumors appeared to increase relative to that of follicular tumors after dietary iodine supplementation was initiated as prophylaxis for goiter; the ratio of papillary:follicular tumors was 1.8 before supplementation and 3.0 after supplementation (Harach and Williams 1995; Harach et al. 1985). The mean urinary iodide concentration before the supplementation was $9 \mu\text{g I/g creatinine}$ and after the supplementation was $110\text{--}150 \mu\text{g I/g creatinine}$; these are approximately equivalent to $17 \mu\text{g I/day}$ ($0.2 \mu\text{g/kg/day}$) and $205\text{--}280 \mu\text{g I/day}$ ($3\text{--}4 \mu\text{g/kg/day}$), respectively.

Radioiodine and Cancer

The thyroid gland receives the highest radiation dose of any organ or tissue following an internal exposure to radioiodine (see Section 3.3, Toxicokinetics) and, therefore, cancer of the thyroid gland is the major health concern associated with radioiodine exposures. Cancer morbidity and mortality among populations who received exposures to radioiodine have been examined in several large-scale epidemiology studies. In general, these studies fall into several categories that can be distinguished by the sources of exposure and estimated radiation doses to the thyroid gland and include (Table 3-3): (1) extremely high exposures and doses ($10\text{--}20 \text{ mCi}$, $370\text{--}740 \text{ MBq}$; $>10,000 \text{ rad}$, $>100 \text{ Gy}$) achieved when ^{131}I is administered to treat hyperthyroidism (even higher doses are used to treat thyroid cancer); (2) lower exposures and doses ($40\text{--}70 \mu\text{Ci}$, $1.5\text{--}2.6 \text{ MBq}$; $80\text{--}130 \text{ rad}$, cGy) associated with clinical administration of ^{131}I for diagnosis of thyroid gland disorders; (3) doses from exposures to fallout from nuclear bomb tests (BRAVO test, $300\text{--}2,000 \text{ rad}$, cGy ; Nevada Test Site, $1\text{--}40 \text{ rad}$, cGy); (4) doses from exposures to releases from nuclear power plant accidents (Chernobyl, $10\text{--}500 \text{ rad}$, cGy); and (5) exposures from operational releases from nuclear fuel processing plants (Hanford Nuclear Site, $0.0001\text{--}284 \text{ rad}$, cGy). As a point of reference, the dose-response relationship for thyroid cancer and external radiation appears to extend down to thyroid doses of 0.1 Gy (10 rad) and predicts an excess relative risk (ERR) of $7/\text{Gy}$ for ages <15 years at exposure (Ron et al. 1995). Studies of thyroid cancers and external radiation exposure have found a strong age dependence between thyroid radiation dose and thyroid cancer. Risk is substantially greater for radiation doses received prior to age 15 years when compared to risks for doses received at older ages (Ron et al. 1995). This same general trend in age-dependence would be expected for internal exposures to radioiodine; thus, studies of adult exposures to radioiodine may not be directly applicable to predicting outcomes from exposures to children. The relatively high and acutely cytotoxic radiation doses to the thyroid gland that are achieved in the treatment of thyroid gland disorders, and outcomes on the thyroid,

3. HEALTH EFFECTS

Table 3-3. Estimated Thyroid Radiation Doses in Populations Studied for Radioiodine-related Cancers^a

Type of exposure	Estimated thyroid radiation dose (cGy) ^a	Reference ^b
Radioiodine therapy for hyperthyroidism	>5,000 ^c	Holm et al. 1991; Ron et al. 1998
Clinical diagnosis of thyroid gland disorders	80–130 ^c	Hall et al. 1996b
Marshall Islands BRAVO test	280–2,100 ^c	Hamilton et al. 1987; Lessard et al. 1985
Chernobyl power plant accident	<1–200 ^d	Astrakova et al. 1998
Nevada Test Site nuclear bomb tests	1–30 ^c	Gilbert et al. 1998; Kerber et al. 1993; Rallison 1996
Hanford Nuclear Site releases	<1–50 ^d	CDC 1999

^a1 cGy=1 rad

^bSee text for additional references

^cCohort means

^d5th–99th percentile range

3. HEALTH EFFECTS

are virtually irrelevant to predicting outcomes from the much lower environmental exposures that occur in most U.S. populations. This is in part because cell killing effects decrease the number of viable cells that might otherwise be transformed by radiation-associated mutagenesis. Uncertainties in estimating thyroid doses are also greater in persons who have thyroid abnormalities because of the nonuniform distribution of radioiodine in the thyroid gland (NCRP 1985). Nevertheless, high-dose studies are summarized because they provide useful information about the magnitude of radioiodine exposures that would present an elevated risk for extrathyroidal cancers. Although not specified in most of these studies, it is likely that radioiodine was administered as a single dose by the oral route as either potassium or sodium iodide, as these are the common clinical practices. However, it is also possible that some patients received the radioiodine by injection. Since absorption of an oral dose of iodide is nearly complete, this is unlikely to be a significant issue in interpreting the outcomes of the studies, except in considering the radiation dose to the gastrointestinal tract.

Breast cancer is also a concern with exposures to high levels of radioiodine after ablative therapy for hyperthyroidism because breast expresses NIS and can transport and accumulate iodide (see Sections 3.4.4.2 and 3.5.1, Distribution). However, the epidemiological literature to date has not implicated such exposures as a significant risk factor for breast cancer (Goldman et al. 1988; Green et al. 1995).

Therapeutic Doses of Radioiodine

A retrospective cohort study conducted in Sweden examined cancer incidence among 10,552 patients (85% females; age 13–74 years) who received ¹³¹I therapy for treatment of Graves' disease (51%) or toxic nodular goiter (42%) (Holm et al. 1991). The mean total activity administered was 506 MBq (13.7 mCi); however, this varied with the objectives of the therapy; 360 MBq (9.7 mCi) for treatment of Graves' disease and 700 MBq (18.9 mCi) for toxic nodular goiter. The distribution of the administered activity in the study population was as follows: 30% <220 MBq (5.9 mCi), mean, 150 MBq (4.1 mCi); 38% 221–480 MBq (6–13 mCi), mean 315 MBq (8.5 mCi); and 32% >480 MBq (13 mCi), mean 1,063 MBq (28.7 mCi). Cancers that occurred from 1 year after treatment (on or after 1958) until either the death of the patient or the end of the calendar year 1985 were considered in the analysis. Expected numbers of cancers were estimated from data from the Swedish Cancer Register for the period 1958–1985. Standard incidence ratios (SIR, observed/expected cancers) were significantly elevated for cancers of the lung (1.32, 95% CI 1.07–1.59) and kidney (1.39, 1.07–1.76). Among toxic nodular goiter patients, who received, on average, twice the dose as Graves' disease patients, the SIR was also significantly elevated for liver cancer (2.14, 1.20–3.52). Among 10-year survivors, significantly elevated SIRs included stomach (1.33, 1.01–1.71), kidney (1.51, 1.06–2.08), and brain (1.63, 1.10–2.32). Doses to specific organs were estimated for each patient based on the administered activity and dosimetry tables developed by the ICRP

3. HEALTH EFFECTS

(1988). Estimated average radiation doses to these tissues were: thyroid gland, >10,000 cGy (>10,000 rad); stomach, 25 cGy (25 rad); lung, 7 cGy (7 rad); kidney, 5 cGy (5 rad); liver, 5 cGy (5 rad); and brain, not reported. There were no significant dose trends. Notably, SIRs for thyroid cancer were not significantly elevated (SIR 1.29, 0.76–2.03). Some of the patients in this study received treatments other than ¹³¹I for thyroid disorders, including antithyroid drugs (14%), surgery (3%), and/or thyroid hormone supplements (2%). Cancer mortality was examined in the same cohort (Hall et al. 1992a). Standard mortality ratios (SMRs) were calculated based on data from the Swedish Cause-of-Death Registry. SMRs were significantly elevated for all cancers (1.14, 1.04–1.24), digestive tract cancers (1.28, 1.16–1.45), and respiratory tract cancers (1.31, 1.01–1.66) among patients who had greater than a 10-year follow up from the date of their exposure to ¹³¹I, and for thyroid gland cancer during the first year (11.45, 2.8–33.72). There were no significant dose trends, although the SMR for thyroid gland cancer was approximately 4 times higher in patients who received >480 MBq (13 mCi) than in patients who received <221 MBq (6 mCi).

A retrospective cohort study examined cancer mortality in 35,593 patients (79% females; mean age, 46 years, 3% younger than 20 years) treated for hyperthyroidism (91% Graves' disease, 8% toxic nodular goiter) in 25 U.S. hospitals and 1 British hospital (Ron et al. 1998). The mean total activity administered was 10.4 mCi (385 MBq; 5th–95th percentile, 3–27 mCi, 111–999 MBq). The mean total administered activity was 10.0 mCi (370 MBq) for treatment of Graves' disease and 17.0 mCi (629 MBq) for toxic nodular goiter. Cancers that occurred between the first visit of the patient to the clinic during the enrollment period (1946–1964) until either the death of the patient or the end of the calendar year 1990 were considered in the analysis. Estimates of expected numbers of cancer deaths were based on U.S. national mortality rates for the period 1958–1985. This study, unlike those of Holm et al. (1991) and Hall et al. (1992a), stratified patients into various categories of treatment, distinguishing patients who received surgical treatments (22% of study population) that would have decreased their thyroid gland mass, and possibly the risks of thyroid cancer. SMRs (observed/expected deaths) were calculated for various treatments (¹³¹I, surgery, antithyroid drugs, or combinations). Radiation doses to specific organs were estimated for each patient based on the administered activity and dosimetry tables developed by the ICRP (1988). The study identified 2,960 cancer deaths, 29 of which were classified as thyroid cancers. Among patients who received only ¹³¹I as treatment, SMRs were significantly elevated for the entire observation period (maximum 44 years) only for thyroid cancer, 4.91 (95% CI, 2.45–8.79). A similar outcome was found for patients who received ¹³¹I along with any other form of treatment. SMRs were significantly elevated among these patients only for thyroid cancer, 3.94 (2.52–5.86) with the highest SMR during the first 4 years after exposure (12.32, 6.38–21.61). The estimated thyroid dose was 50–70 Gy (5,000–7,000 rad). When cancer mortality of toxic nodular goiter patients who received ¹³¹I treatment was evaluated separately, SMRs for cancers of the esophagus (4.06, 1.10–10.45) and uterus (2.05, 1.02–3.67) were significantly elevated, in addition to thyroid cancer (18.88, 7.58–38.98). Estimated doses to the

3. HEALTH EFFECTS

nonthyroid tissues was less than 100 mGy (100 rad). However, in Graves' patients who received ^{131}I treatment, SMRs were significantly elevated only for thyroid cancer (2.84, 1.62–4.61). There were no significant dose trends for cancer in thyroid or other organs, although the SMR for patients who received 15 mCi (555 MBq) was 2.28 times higher (7.05) than in patients who received <7 mCi (3.01), when all patients who received ^{131}I treatments were considered. Unlike the Holm et al. (1991) and Hall et al. (1992a) studies, the Ron et al. (1998) study found a significantly elevated risk for thyroid cancer among patients who received ^{131}I treatment; however, it did not find elevated risks for other organs. Potential contributors to this difference in outcomes may be: (1) the larger size of the cohort in the Ron et al. (1998) study (35,593 compared to 10,646); (2) a larger fraction of the study population in the Hall et al. (1992a) study that received higher activities of ^{131}I for toxic nodular goiter (42% compared to 8%); and (3) stratification of the patients in the Ron et al. (1998) study into treatment categories that so that patients who received only ^{131}I or ^{131}I in combination with other treatments could be assessed independently. Much of the apparent excess risk for thyroid cancer deaths observed in the Ron et al. (1998) study occurred during the first 0–4 years after ^{131}I treatment, which would suggest a remarkably short latency for a radiation-induced cancer, or possibly other factors that contributed to the outcome. Although a larger fraction of the study population in the Hall et al. (1992a) study received higher activities of ^{131}I for toxic nodular goiter (42%) compared to (8%) in the Ron et al. (1998) study, this does not explain the difference in thyroid cancer outcomes since the Ron et al. (1998) study found higher risks for thyroid cancer among patients who received higher exposures to ^{131}I for treatment of toxic nodular goiter.

A follow-up cohort study was conducted of cancer morbidity and mortality among 1,762 women who received ablative ^{131}I therapy for hyperthyroidism during the period 1946–1964 (Goldman et al. 1988). The follow-up period was 17 years. SMRs and SIRs were estimated based on age-, date-, sex-, and race-specific mortality incidence and mortality of the United States or Massachusetts population. The cohort was stratified into treatment categories that included only ^{131}I or ^{131}I in addition to other therapies for hyperthyroidism. SIRs in the ^{131}I -only group were not significantly elevated for any cancer type or group. SMRs in the ^{131}I -only group were significantly elevated for cancers of all causes (SMR, 1.2, 1.1–1.4, 95% CI, 10 cases). There were no significant radiation dose trends. Exposures ranged from 0.1 to >10 mCi (4–370 MBq).

Diagnostic Doses of Radioiodine

A retrospective cohort study examined thyroid cancer incidence among 34,104 patients (80% females, 1–75 years of age) in Sweden who received ^{131}I for diagnosis of thyroid disorders during the period 1950–1969. The follow-up period was from 1958 to 1990 (Hall et al. 1996b). A total of 2,408 patients (7%) were exposed before 20 years of age and 316 patients were exposed before 10 years of age (1%). The diagnostic test was for a suspected thyroid tumor in 10,785 (32%) patients and for hypothyroidism,

3. HEALTH EFFECTS

hyperthyroidism, or other reasons in 23,319 (68%) patients. The follow-up period ranged from 5 to 39 years after exposure (thyroid cancers detected within 5 years of the diagnostic test were excluded on the basis that they may have been related to cancer present at the time of the diagnostic test). The mean total activity administered was 2.4 MBq (65 μ Ci) for patients suspected of having a thyroid gland tumor and 1.6 MBq (43 μ Ci) for other patients. Radiation doses to the thyroid gland were estimated for each patient based on the administered activity and dosimetry tables developed by the ICRP (1988). The mean absorbed dose was 1.3 Gy (130 rad) for suspected thyroid tumor patients and 0.8 Gy (80 rad) for other patients. SIRs were calculated based on sex-, age-, and date-adjusted cancer incidence rates based on the Swedish Cancer Registry. Sixty-seven thyroid tumors were identified during the period of the study, of which 42 (63%) were in patients who received ^{131}I for diagnosis of a suspected thyroid gland tumor. SIRs were significantly elevated only in the latter group (2.86, 95% CI 2.06–3.86), but not in patients tested for other suspected thyroid disorders. There were no significant dose trends for thyroid cancer in either group.

The incidence of cancer in extrathyroidal organs was examined in this same cohort (Holm et al. 1989). At that time, the cohort consisted of 35,074 patients, 31% of whom received ^{131}I for diagnosis of a suspected thyroid gland tumor, 42% for suspected hyperthyroidism, 16% for suspected hypothyroidism, and 8% for other reasons (the basis for the diagnostic procedure could not be determined for 3% of the patients). The mean total activity administered was 52 μ Ci (range 1–960 μ Ci) (1.9 MBq, 0.04–36 MBq). The mean total administered activity was 71 μ Ci (2.6 MBq) for patients suspected of having a thyroid tumor, 48 μ Ci (1.8 MBq) for diagnostic tests for hyperthyroidism, and 40 μ Ci (1.5 MBq) for other diagnostic purposes. SIRs were significantly elevated for cancers of the endocrine organs other than thyroid gland (1.93, 1.62–2.29), lymphomas (1.24, 1.03–1.48), and leukemias (1.34, 1.11–1.60). The SIR for nervous system cancers was 1.19 (1.00–1.41). The SIR for thyroid cancer was significantly elevated only in the 5–9-year period of follow-up. There were no significant dose trends. In this study, unlike the Hall et al. (1996b) study, SIRs were calculated for all patients, regardless of the intended purpose of the diagnostic test, including patients who were administered ^{131}I for the diagnosis of suspected thyroid tumors.

A prospective study examined thyroid outcomes of children and adolescents (<20 years old) who received diagnostic doses of ^{131}I during the period 1946–1967 (Hamilton et al. 1987). Study groups consisted of 3,503 subjects who received diagnostic ^{131}I , 2,495 control subjects who did not receive ^{131}I and who were matched with the exposed subjects by sex-, age-, and diagnostic-test date, and a group of 1,070 siblings of the control group. The follow-up period was from entry into the study until 1986. Participants were surveyed with a questionnaire to identify those who had thyroid or neck surgery during the study period, and pathology reports and specimens were retrieved and reviewed by a panel of pathologists; neoplasms were classified and the results were compared with hospital pathology reports. Dose to the thyroid gland was estimated for each exposed subject based on the reported activity administered, percent thyroid uptake, and thyroid weight estimated from published thyroid growth tables. The median total absorbed

3. HEALTH EFFECTS

dose was 20–40 rad (0.2–0.4 Gy) (95th percentile, 200–330 rads 2–3 Gy). The survey response rate was 63%. A total of 34 surgeries were reported, of which 19 were on subjects who did not have any thyroid disorder diagnosed at the time of entry into the study; 16 of these subjects had confirmed thyroid tumors; 10 benign, 8 of which occurred in the exposed group, and 6 malignant tumors, 5 of which occurred in the exposed group. Although these results are suggestive of a possible effect of ¹³¹I exposure on thyroid tumor incidence, the differences between the exposed and control groups were not statistically significant. Shore (1992) reviewed the results of the Hamilton et al. (1987) study and calculated a relative risk for thyroid cancer of 2.9 (90% CI, 0.6–15) based on the internal comparison of the exposed and unexposed groups in the Hamilton et al. (1987). Based on the Surveillance, Epidemiology and End Results (SEER) cancer data for 1973–1981 (U.S. DHHS 1985), 3.7 thyroid cancers would have been expected in the Hamilton et al. (1987) study, compared to the 4 observed during the period of 5 or more years after the diagnostic test (one of the cancers reported in the Hamilton et al. (1987) study occurred with a latency of 2 years), which, according to Shore (1992), indicates a SIR of 1.1, (95% CI, 0.3–2.6).

Marshall Islands Nuclear Bomb Test BRAVO. Several epidemiological studies have examined thyroid gland disorders in residents of the Marshall Islands who were exposed to radioiodine from atmospheric fallout resulting from nuclear bomb tests (including the so-called BRAVO test). A more complete discussion of these studies are presented in Section 3.2.1.2 (Endocrine), as the studies provide dose-response information on thyroid disorders other than cancer. However, cancer outcomes have been examined in what has become known as the BRAVO cohort, as well as in larger samples of the Marshall Island population. Almost all that is known about radioiodine doses to the thyroid from the BRAVO test exposures derive from a few urinary measurements collected 15 days after the exposures. These have been estimated to have been (external and internal): 3.3–20 Gy (300–2,000 rad) on Rongelap (highest doses in children), 1.3–4.5 Gy (130–450 rad) on Ailingnae, and 0.3–0.95 Gy (30–95 rad) on Utirik (Conard 1984). The BRAVO test was not the only potential source of radioiodine exposure in the Marshall Island population, as numerous bomb tests were conducted in the Marshall Islands during the period 1946–1958.

Evidence for a higher prevalence of thyroid cancer among the original 250 people known to have been heavily exposed as a result of the BRAVO incident has not been established; however, this may reflect the small size of the cohort. In 1982, a review of the diagnoses for thyroid nodules detected in 250 exposed and 1,303 nonexposed Marshallese revealed 9 definitive carcinomas (3.6%) and 7 adenomas (2.8%) in the exposed group, and 6 carcinomas (0.5%) and 14 adenomas (1%) in the nonexposed comparison group (Conard 1984). Subsequent reviews of the thyroid pathology more or less agree with the conclusions of Conard (1984), although differences in the composition of comparison group have contributed to slightly different estimates of prevalence in the nonexposed population. For example, Howard et al. (1997) reported four cancers (1.8%) and one adenoma (0.4%) in a nonexposed comparison group. Takahashi et al. (1997) reviewed diagnoses of 22 cases of thyroid nodularity discovered in 1993 in an ultrasound

3. HEALTH EFFECTS

screening program that evaluated 1,275 Marshall Island residents (mainly from Ebeye). The prevalence of thyroid cancer among patients referred for surgery-based thyroid gland ultrasound assessments suggested an overall prevalence of thyroid cancer of approximately 1.2% (15/1,275) in the population evaluated, or a 12% prevalence (15/123) of thyroid cancer among those who had palpable nodules. Several factors confound attempts to associated thyroid cancers in the Marshall Islands population with radioiodine exposures, including lack of definitive dosimetry, outside of the small BRAVO cohort. Changes occurred in diagnostic techniques used to detect thyroid nodules, which would direct further diagnostic attention; in particular, the use of ultrasound for detecting small thyroid nodules began only in 1994. More recent studies have also suggested a relatively high prevalence of iodine deficiency in the Marshall Islands, which may have affected background thyroid cancer prevalence (Takahashi et al. 1999).

The strengths of the Marshall Island studies summarized above include the relatively high range of thyroid radiation doses and the multiple thyroid screenings that included, in the more recent studies, relatively objective assessments of nodularity by ultrasound. Limitations of the studies include: (1) large dose uncertainties in terms of total thyroid dose; (2) further dose uncertainties in terms of the fraction of the dose that was from ^{131}I rather than from short-lived isotopes of iodine and gamma radiation; (3) no attempt to estimate individual thyroid doses; (4) inequities between the exposed and unexposed populations in the intensity of thyroid screening; (5) the relatively small number of exposed subjects in the BRAVO cohort; (6) the potential confounding effects of prophylactic iodide administration to highly exposed subjects; and (7) thyroid radiation dose estimates were not available for larger scale studies of populations in the Marshall Islands.

Nevada Test Site Nuclear Bomb Tests. During the period 1951–1958, 119 atmospheric nuclear bomb tests were conducted at the Nevada Test Site (NTS) in southern Nevada (NCI 1997). These tests were followed by nine surface detonations during the period 1962–1968 and approximately 809 below-ground tests, of which 38 were determined to have resulted in off-site releases of radioactive materials. A dose estimation methodology was developed by the National Cancer Institute (NCI 1997), which has enabled estimation of population radiation doses to the thyroid gland from direct and indirect (e.g., *in utero*, ingestion of cow milk) exposures to ^{131}I resulting from the NTS activities for the purpose of health assessments and epidemiologic investigations (Gilbert et al. 1998; Kerber et al. 1993). A discussion of the uncertainties and limitations of these population dose estimates for use in epidemiology studies and risk assessment can be found in a review of the NCI (1997) dose estimations conducted by the Institute of Medicine and the National Research Council (NRC 1999).

A cohort study examined thyroid nodularity and performed diagnostic follow up in 2,678 adolescents (age 11–18 years) who resided in Utah or Nevada near the NTS during the early 1950s and in a comparison population of 2,132 adolescents who lived in Arizona. Examinations were conducted during the period

3. HEALTH EFFECTS

1965–1970 (Rallison et al. 1974). In a follow-up study conducted in 1985–1987, 1,962 of the original Utah-Nevada group and 1,160 from the Arizona group were reexamined (Rallison et al. 1990). Radioiodine doses were estimated for each Utah-Nevada subject based on self-reported histories of residence, local milk and leafy vegetable consumption, records of transport and deposition of radionuclides at their town and/or county of residence, and age-specific transfer factors relating iodine ingestion with iodine uptake in the thyroid gland (Kerber et al. 1993; Simon et al. 1990). Mean thyroid dose estimates were 150 mGy (15 rad) (maximum 4.6 Gy, 460 rad) in the Utah group, 50 mGy (5 rad) (maximum 0.84 Gy, 84 rad) in the Nevada group, and 13 mGy (1.3 rad) (maximum 0.45 Gy, 45 rad) in the Arizona group (the group names refer to cohort designations used in the study, which were based on the place of residence during the potential exposure period, and not necessarily where the entire radiation dose for each individual was received). In the 1965–1968 examinations, 76 of 4,819 people examined had palpable thyroid gland nodules, 22 of which were subsequently diagnosed as adenomas (20) or carcinomas (2). The prevalence of nodules was higher in the Utah-Nevada group (19.7/1,000) than in the Arizona group (10.8/1,000). Fifteen of the 22 neoplasms were found in the Utah-Nevada group (5.6/1,000) and 7 in the Arizona group (3.3/1,000) (Rallison et al. 1974). In 1985–1987, 125 new cases of thyroid nodularity were identified, 65 of which were diagnosed as neoplasms and 5 of the latter were carcinomas. Five carcinomas were reported in the group during the interval between the two examinations. Combining the results of the first and second evaluations, including the five carcinomas observed during the interval, resulted in similar prevalences in the two groups for nodules (Utah-Nevada 48.6/1,000, Arizona 36.6/1,000). Prevalence of neoplasms were not disparate: Utah-Nevada, 2.8/1,000 and Arizona 4.8/1,000 (Rallison et al. 1990). Thyroid nodules were detected in 56 of 2,473 subjects; 38 of these lesions were diagnosed as nonneoplastic (28 were colloid adenomas, the other 10 were miscellaneous nonneoplastic lesions), 11 were benign adenomas (of these, 8 were follicular adenomas and there was one each of papillary, fetal, and Hurthle cell adenomas), and 8 were papillary carcinomas (Rallison 1996). Stratifying the outcomes by estimated thyroid radiation dose revealed a significant dose trend for neoplasms, but not for all nodules or for carcinomas alone. The group that received a dose exceeding 0.25 Gy (25 rad) had a thyroid neoplasm prevalence of 21–24/1,000, whereas groups that received <0.25 Gy had a prevalence of 4–5/1,000. The excess relative risk estimates per Gy were: neoplasms, 7.0 (lower 95% confidence limit [CL], 0.74, $p=0.019$); nodules, 1.2 (95% CL<0, $p=0.16$); and carcinomas, 7.9 (95% CL<0, $p=0.096$) (Kerber et al. 1993).

In a large scale ecological study, mortality and incidence of thyroid cancer in 3,053 U.S. counties were compared to estimated exposures to ^{131}I from releases from the NTS (Gilbert et al. 1998). Thyroid cancer mortality data were obtained from the National Center for Health Statistics for 1957–1994 and thyroid cancer incidence data from SEER for the period 1973–1994. County-specific or state-specific cumulative radiation doses were reconstructed based on NCI (1997) and were as follows (cGy, where 1cGy = 1 rad): *in utero*, 4.3 cGy; 0–<1 year, 12.6 cGy; 1–4 years, 10.0 cGy; 5–9 years, 6.7 cGy; 10–14 years, 4.4 cGy;

3. HEALTH EFFECTS

15–19 years, 3.1 cGy; ≥20 years, 1.1 cGy. During the study period, there were 12,657 cases of thyroid cancer and 4,602 thyroid cancer deaths. Age-, calendar-, sex-, and count-specific mortality and incidence rates in the U.S. were analyzed in relation to ¹³¹I dose estimates, taking into consideration geographic location, age at exposure, and birth cohort. There were no significant dose-related trends (linear excess relative risk model) in either thyroid cancer mortality or incidence when all exposure age groups were composited or when exposure age groups 1–5 years or 1–15 years were considered separately. However, when the exposure age group <1 year was analyzed, a dose trend was weakly suggested by highly positive excess relative risks (ERR) for thyroid cancer deaths when doses were county-specific (ERR 10.6 per Gy, 95% CI -1.1–29, p=0.085) or state-specific (16.6 per Gy, -0.2–43, p=0.054), and for thyroid cancer incidence when doses were county-specific (2.4 per Gy, -0.5–5.6). These outcomes were strongly influenced by two deaths and nine cases of thyroid cancer that occurred in individuals who received estimated cumulative doses exceeding 9 cGy (9 rad) before they were 12 months of age.

The strengths of the NTS studies described above include the attempt to develop a systematic sampling frame, the careful, multiple thyroid screenings (two or more times), the relatively high follow-up rate, and the extensive attempt to characterize individual ¹³¹I doses. Limitations of the studies include: (1) the substantial dose uncertainties, since no thyroid exposure measurements were available and individual milk and vegetable consumption was recalled more than 30 years after the fact; (2) the food-consumption and behavioral questionnaire was conducted after subjects knew their thyroid outcomes; (3) the modest sample size and, therefore, small number of thyroid neoplasms found, which limited the statistical power and precision; (4) the relatively low dose range also limited the statistical power and precision; (5) the restriction of the thyroid examinations to palpation (no ultrasound); and (6) the fact that the thyroid examinations were only partially blinded (i.e., examiners often knew the subject's geographic region).

Chernobyl Nuclear Power Plant Accident. Clinical records from the Republics of Belarus and Ukraine show an increase in the incidence of thyroid cancer in children and adolescents, which became apparent approximately 4 years after the release of radioactive materials from the Chernobyl nuclear power plant in April 1986 (Cherstvoy et al. 1996; Drobysheskaya et al. 1996; Tronko et al. 1996). Belarus recorded an annual incidence of 0.09 cases per 100,000 in 1986 among children between the ages of 4 and 17 years and 2.46 per 100,000 in 1991, with the highest incidence in the Gomel oblast; from 0.24 cases per 100,000 in 1986 to 12.5 per 100,000 in 1991 (Drobysheskaya et al. 1996). In the Ukraine, annual incidence of thyroid cancer in children and adolescents (under 19 years of age) increased from approximately 0.05 per 100,000 prior to 1986 to 0.43 per 100,000 in 1992 (Tronko et al. 1996). In 1994, the incidence (per 100,000) was highest in regions nearest to Chernobyl: Chernihiv, 3.8; Zhytomyr, 1.6; and Kiev, 1 (Tronko et al. 1996). Although the available data strongly show that radiation exposure from the accident has led to the excess risk of thyroid cancer, especially in persons exposed as children, there is also much uncertainty in the radiation dose estimates. The magnitude of the thyroid cancer risk associated with

3. HEALTH EFFECTS

radioiodine is also highly uncertain because of factors that complicate the epidemiological picture, including the contribution external exposure, the effect of the intensive screening for thyroid cancer that followed the accident (Astakhova et al. 1998) on the baseline incidence of thyroid cancer, and the potential effects of iodine deficiency and endemic goiter in the population (Gembicki et al. 1997).

The relationship between childhood thyroid cancer and radiation exposure was examined in a case-control study of children from Belarus (Astakhova et al. 1998). Cases included all children under age 15 years at the time of the accident who had confirmed pathology diagnoses of thyroid cancer during the period 1987–1992 and who could participate in the study (107 of 131 applicable cases in Minsk State Medical Institute records). Cases were matched with two control groups; one control group (Type 1) was randomly selected from an area of Belarus thought to have relatively low or no exposures from the Chernobyl accident (Brest, Grodno, and Vitebsk oblasts in north and west Belarus) but was otherwise matched with cases for age, sex, and urban/rural residence. A second control group (Type 2) was drawn from each Belarus district, including the more heavily exposed oblasts near Chernobyl (Minsk, Mogilev, and Gomel), in numbers proportional to the population census and was matched to cases by pathway to diagnosis, in addition to age, sex, and urban/rural residence. The objective of matching the pathway to diagnosis was to control for screening intensity as a possible contributor to an increased incidence. Diagnosis pathways were classified into three elements: (1) systematic endocrine screening; (2) incidental finding during physical examination not necessarily related to the Chernobyl releases; or (3) examination prompted by referral because of a swelling of the neck or other symptoms of possible thyroid enlargement or nodularity.

Average thyroid radiation doses were reconstructed based on thyroid gland ^{131}I measurements made on 200,000 residents of Belarus, after the Chernobyl release, and estimates of cow milk contamination and consumption for the area of residence of each case or control (vegetable and goat milk consumption was not included in the exposure estimates). If no cow milk consumption was thought to have occurred, exposure was assumed to have occurred principally from inhalation. Age-group thyroid doses were constructed for each area of residence included in the study. Mean (standard deviation) of thyroid doses in the case group and controls were as follows: cases, 535 mGy (848) mGy; Type I controls, 188 mGy (386); and Type II controls, 207 mGy (286). For the purpose of estimating ORs, cases and controls were stratified into three thyroid dose categories. The resulting estimated dose distributions among thyroid cancer cases were 64/107 (59.8%) in the <0.3 Gy dose category, 26/107 (24.3%) in the 0.3–0.99 Gy dose category, and 17/107 (15.9%) in the \$1 Gy dose category. The corresponding distributions in Type 1 controls were 88/107 (82.2%) for <0.3 Gy, 15/107 (14.0%) for 0.3–0.99 Gy, and 4/107 (3.7%) \$1 Gy. The corresponding OR for the \$0.3 Gy category compared to <0.3 Gy was 3.11 (95% CI, 1.67–5.81) and for the \$1 Gy category compared to <0.3 Gy was 5.84 (1.96–17.3). ORs were significant when Type 2 controls were the comparison group (controls for pathway to diagnosis). For routine endocrine screening, ORs were 2.08 (1.0–4.3) for comparison of the dose categories \$0.3 Gy and <0.3 Gy, and 5.04 (1.5–16.7)

3. HEALTH EFFECTS

when the dose category ≥ 1 Gy was compared to <0.3 Gy. The OR for incidental findings was significant, 8.31 (1.1–58) when the dose category ≥ 0.3 Gy was compared to <0.3 Gy. These results suggest that radiation dose to the thyroid gland was a significant contributor to thyroid cancers diagnosed in children who lived in Belarus during and after the Chernobyl releases and that this contribution is evident at doses exceeding 0.3 Gy.

An analysis of 251 thyroid cancer cases in children (14 years or younger) from Belarus who were diagnosed during the period 1986–1993 revealed a dose trend in incidence when the cases were organized by districts that reflected their respective mean thyroid doses (Drobyshevskaya et al. 1996). Incidence ranged from 81 to 201 per 100,000 where estimated average thyroid doses were above 1 Gy (1.2–1.6 Gy, 120–160 rad), and 14–55 per 100,000 where doses were between 0.1 and 0.5 Gy (10–50 rad). The highest incidence occurred in Bragin where individual thyroid doses were estimated to have ranged from 0.8 to 20 Gy (560, 80–2,000 rad) (mean, 5.6 Gy, 560 rad). Incidence was 9 per 100,000 in Braslav where the lowest measurable thyroid doses were reported (mean, 0.005 Gy, 0.5 rad). Children who were under 3 years old or *in utero* at the time of exposure accounted for 53% of thyroid cancer cases. This age-group was estimated to have received a thyroid radiation dose that was approximately 2–3 times that for older children (approximately 1.4 Gy average dose). However, 52% of the cancers were diagnosed in children who received an estimated thyroid dose of <0.3 Gy and 84% in children who received doses <1 Gy. Children under 3 years old accounted for 38% of the cancer cases among children exposed to <0.3 Gy. These results suggest that young children were particularly susceptible to lower radiation doses.

An analysis of 531 thyroid cancer cases in children and adolescents (under 18 years of age) from Ukraine who were diagnosed during the period 1986–1994 revealed that 55% of the cases were under age 6 years on the date of the Chernobyl release (Tronko et al. 1996). The annual incidence of thyroid cancer in children and adolescents (under 19 years of age) increased from approximately 0.05 per 100,000 prior to 1986 to 0.43 per 100,000 in 1992. In 1994, the incidence (per 100,000) was highest in regions nearest to Chernobyl: Chernihiv, 3.8; Zhytomyr, 1.6; and Kiev, 1 (Tronko et al. 1996). Thyroid radiation doses were estimated to have ranged from 0.01 to >1.5 Gy in the case group analyzed. Approximately 20% of the cases were estimated to have been exposed to 0.01–0.05 Gy (1–5 rad) and 80% to 0.1–0.3 Gy or less (10–30 rad).

Further evidence that the Chernobyl releases probably contributed to the observed increase in thyroid cancer incidence comes from a study of the demographics and pathology of thyroid cancers in Belarus and Ukraine with those diagnosed in Italy and France during the same time period (Pacini et al. 1997). Thyroid cancers cases in 472 children and adolescents <21 years of age diagnosed in Belarus and Ukraine during the period 1986–1995 were evaluated. These included approximately 98% of all childhood cases reported during that period. The comparison group consisted of 369 cases of the same age groups

3. HEALTH EFFECTS

consecutively diagnosed at two clinics in Italy (n=219) and France (n=150). The study revealed several differences in the Belarus-Ukraine cases when compared with the Italy-France cases. Most of the Belarus-Ukraine cases were 5 years of age or less, whereas most of the Italy-France cases occurred after age 14 years. The female:male ratio of the Italy-France cases was significantly higher (2.5) than the ratio in the Belarus-Ukraine cases (1.6). Most (94%) of the Belarus-Ukraine cases were papillary carcinomas with follicular carcinomas accounting for only 5% of cases, whereas 82% of the Italy-France cases were papillary and 15% were follicular carcinomas. Cancers diagnosed in the Belarus-Ukraine group, typical of thyroid cancer in early childhood, tended to be more invasive with extrathyroidal involvement more frequently than in the Italy-France cases. The Belarus-Ukraine cases also had a higher incidence of thyroid autoimmunity (i.e., elevated antithyroid peroxidase and thyroglobulin antibodies) than the Italy-France cases. These results suggest different factors contributed to the Belarus-Ukraine and Italy-France cases, radiation dose possibly being at least one factor.

In both Belarus and the Ukraine, the highest rates of childhood thyroid cancer have occurred in areas where exposure to other industrial contaminants are likely to have occurred and where there is evidence for widespread iodine deficiency. These factors may have affected the early appearance of thyroid cancer after the accident, when vigorous public health screening programs for thyroid abnormalities were initiated. The incidence of thyroid cancer prior to the accident in these areas was poorly documented (Nikiforov and Fagin 1998).

The strengths of the Chernobyl thyroid studies described above include: (1) the large number of children who received substantial thyroid doses; (2) the studies included thyroid exposure measurements on more than 100,000 children; (3) the generally high level of thyroid surveillance in the population after the accident; and (4) that many children were screened with ultrasound, which provides relatively objective evidence of thyroid nodularity; one study (Astakhova et al. 1996) attempted to control for the intensity of thyroid surveillance. Limitations of these studies include: (1) substantial dose uncertainties and use of average doses in many of the studies rather than estimates of individual doses; (2) no thyroid dose estimates for many of the thyroid cancer cases; (3) the presence of iodine deficiency in the study populations may have affected both the thyroid radiation dose received from ¹³¹I as well as the likelihood of a thyroid neoplasm; (4) greater intensity of thyroid screening and surveillance in the areas of highest exposure than in areas of lower exposure; and (5) lack of rigorous epidemiologic study designs in many of the studies (i.e., no systematic sampling design, no blinding of examiners with respect to likely thyroid dose, and irregular variations in thyroid screening).

Hanford Nuclear Site Releases. The CDC (1999) has conducted a follow-up prevalence study of thyroid cancer in populations who resided near the Hanford Nuclear Site in southeastern Washington during the period 1944–1957. At the time this profile was developed, a draft report of this study was available from

3. HEALTH EFFECTS

the Fred Hutchinson Cancer Research Center web site (<http://www.fhrc.org/science/phs/htds/>); however, a final published report was not available. The study included 3,441 subjects who were born during the period 1940–1946 in counties surrounding the Hanford Nuclear Site. Thyroid disease was assessed from a clinical evaluation of each subject, which included assessments of ultrasound or palpable thyroid nodules. Historical information on thyroid disease and information on radiation exposures were obtained by interviews and, when possible, review of medical records of participants, including pathology slides to confirm cancer diagnosis. Thyroid radiation doses were estimated using a dosimetry model developed in the Hanford Environmental Dose Reconstruction Project. Information on residence history and relevant food consumption patterns (e.g., milk consumption, breast feeding, consumption of locally harvested produce) for each study participant was obtained by interview. The estimated mean thyroid radiation dose, based in 3,190 participants, was 182 mGy (± 227 , SD) (18.2 ± 22.7 rad) and the range was 0.0008–2,842 mGy (0.00008–284 rad). Doses varied geographically, with the highest doses received by people who lived near and downwind from the site. Dose-response relationships were assessed using a linear regression model with adjustments for the following confounding and effect modifying variables: sex, age of first exposure, age of evaluation, ethnicity, smoking, and potential exposures from Nevada Test Site releases. Alternatives to the linear model were also explored including linear quadratic and logistic models. Incidences of thyroid carcinoma or nodules were found to be unrelated to thyroid radioiodine dose. As noted above, a final report of conclusions has not been published and the study is currently under review by the National Research Council. Strengths of the Hanford study include: (1) the extremely careful study design and methods; (2) the systematic sampling and high rates of subject location and participation; (3) blinded thyroid assessments by multiple examiners, along with ultrasound which is a more objective assessment of thyroid nodularity; and (4) extensive attempts to model thyroid radiation doses in various locales, combined with self-reported or parent-reported estimates of milk and vegetable consumption to estimate individual thyroid doses. Limitations of the Hanford study include substantial individual dose uncertainties, since no thyroid exposure measurements were available and individual milk and vegetable consumption estimates were recalled 30–40 years after the exposure period studied; and statistical power and precision were limited by the model's sample size and relatively low dose range.

3.2.3 Dermal Exposure

3.2.3.1 Death

No information was located on deaths associated with dermal exposure to iodine.

3. HEALTH EFFECTS

3.2.3.2 Systemic Effects

No information was located regarding respiratory, cardiovascular, gastrointestinal, hematological, musculoskeletal, hepatic, renal, dermal, ocular, body weight, or other systemic effects of dermal exposure to iodine or radioiodine

Endocrine Effects. Povidone-iodine is a complex of I₂ and polyvinyl pyrrolidone and is widely used as a topical antiseptic for mouth, skin, and vaginal infections, and surgical procedures. Topical preparations of povidone-iodine contain approximately 9–12% iodine, of which a small fraction is in free solution (Lawrence 1998; Rodeheaver et al. 1982). Dermal exposure to povidone-iodine has induced acute toxicity in humans. In one case, hyperthyroidism and thyrotoxicosis developed in an adult male who, for 6 months, received povidone-iodine skin washes to treat dermal ulcers but had no other history of excess iodine intake or treatment with iodine-containing drugs (Shetty and Duthie 1990). The patient had elevated antithyroglobulin and thyroid peroxidase (thyroid microsomal) antibodies. The disorder eventually required therapy with propylthiouracil and radioiodine. It is possible that the povidone-iodine exposure may have aggravated a pre-existing autoimmune disorder in the patient rather than having been the cause of the thyrotoxicosis.

Several cases of hypothyroidism induced by topical applications of povidone-iodine to wounds have been described. In one case, an adult female was exposed to approximately 22 mg iodine as povidone-iodine, 3 days/week for 22 months, when an open fistula was swabbed with povidone-iodine and packed with iodoform impregnated gauze (Prager and Gardner 1979). The patient developed clinical hypothyroidism with thyroid enlargement and became euthyroid within 6 weeks after the iodine treatment of the wound was discontinued. In a study of 27 neurological ward patients who received topical povidone-iodine treatments for various procedures and for periods of 3–133 months, serum iodide, T₄, and FT₄ concentrations were significantly higher than a group of 13 patients who did not receive povidone-iodine treatments (Nobukini et al. 1997). Eight of the 27 patients who received povidone-iodine treatments were clinically hyperthyroid (serum FT₄ concentration above the normal range) and 3 of 27 patients were suspected of having subclinical hypothyroidism (serum TSH concentrations above the normal range). None of these patients had elevated antithyroglobulin or thyroid peroxidase antibodies, suggesting that thyroid autoimmunity was not the cause of the apparent thyroid hormone disturbances. Serum FT₄ concentrations were significantly positively correlated with the duration of povidone-iodine exposure.

Povidone-iodine gels are used for vaginal lubrication during labor checks prior to delivery. Use of povidone-iodine gels has been associated with increased serum iodide concentrations as well as changes in thyroid hormone status, indicative of subclinical thyroid gland suppression. In a study of 18 women who received intravaginal treatments with povidone-iodine gel during labor checks, serum iodide

3. HEALTH EFFECTS

concentrations were significantly higher after the applications than before the applications (Jacobson et al. 1984). Serum TSH concentrations were significantly elevated (5.9 mU/L) in the povidone-iodine group compared to a group of 13 women who received vaginal lubricants that did not contain iodine (1.9 mU/L). There were no differences in the levels of T_4 or T_3 between the iodine and no-iodine groups.

Use of povidone-iodine for topical disinfection and surgical wound disinfection in infants has been shown to induce hypothyroidism and hyperthyroidism. In a prospective study, 17 premature infants (#36 weeks gestation), who were euthyroid with no indications of thyroid disorders, received topical povidone-iodine applications for various procedures beginning within 24 hours of birth (Brown et al. 1997). Five of 17 (29%) of the infants had a significant decrease (<50% of pretreatment value) in their serum T_4 concentrations compared to none of 14 control infants who received the same clinical procedures, but with topical application of a noniodine disinfectant (chlorhexidine). These five infants had serum T_4 concentrations that were below 40 nmol/L (3.1 $\mu\text{g/dL}$) 4–6 days after exposure to povidone-iodine, indicating a clinical hypothyroidism (60 nmol/L is low end of normal range), although their serum TSH concentrations were not elevated (<20 mU/L, de Zegher et al. 1994; Momotani et al. 1992). Their T_4 status reverted to normal within 10–25 days after treatment. There were no significant differences between the treatment and control group mean values for serum T_4 or TSH. Iodide concentrations in random untimed urine samples were approximately 24 times higher in the treatment group (1,800–3,600 $\mu\text{g/L}$) than in the control group (90–150 $\mu\text{g/L}$), indicating absorption of some of the topically applied iodine. In a study of 30 intensive care ward infants who received frequent topical applications of povidone-iodine for various procedures, five patients (20%) developed clinical hypothyroidism with serum T_4 and T_3 concentrations below the normal range, serum TSH concentrations above the normal range, and thyroid gland enlargement (Chabrolle and Rossier 1978a, 1978b). Urinary iodide excretion rates at the time of treatment ranged from 2.9 to 4.8 mg I/day in four of the patients and was 0.14 mg I/day in one of the patients, suggesting daily absorbed doses of iodine in this same range. The thyroid hormone status reverted to normal after the povidone-iodine treatments were discontinued. A 30% incidence of hypothyroidism was reported in 10 intensive care ward newborns who received topical povidone-iodine applications for various procedures for >2 days in duration (l'Allemand et al. 1987). A newborn infant who received povidone-iodine irrigations of wound drains became clinically hyperthyroid without elevated serum titres of antithyroglobulin or thyroid peroxidase (thyroid microsomal) antibodies (Bryant and Zimmerman 1995). The patient became euthyroid within 1 month after the povidone-iodine irrigations were discontinued. Thyroid status of four infants with spinal bifida who received daily povidone-iodine antiseptic dressings were followed; two of the four patients became hypothyroid after 4 weeks of exposure and required treatment with T_4 (Barakat et al. 1994). The patients became euthyroid within 9 months after the povidone-iodine applications were discontinued. In a study of 47 neonatal intensive care patients who were exposed to topical povidone-iodine for varying lengths of time, no evidence was found of thyroid suppression or hypothyroidism (Gordon et al. 1995).

3. HEALTH EFFECTS

Topical application of povidone-iodine during labor has been found to produce thyroid gland suppression in newborns. In a study of 30 women who received topical povidone-iodine in preparation for a cesarean section, newborn serum TSH concentrations (cord blood) were significantly higher than in newborns from 12 mothers who also underwent a cesarean section, but who were not exposed to povidone-iodine (Novaes et al. 1994); however, the levels were not above the normal range for newborns (>20 mU/L, de Zegher et al. 1994; Momotani et al 1992). Serum concentrations of T_4 and T_3 were not different in the two groups of newborns. In a study of infants delivered by mothers who received intravaginal povidone-iodine during labor checks, serum TSH concentrations were significantly higher and T_4 and T_3 concentrations were significantly lower compared to 18 control infants delivered from mothers who were not exposed to povidone-iodine during labor (l'Allemand et al. 1983). Twenty percent of the infants from the treated mothers had serum TSH concentrations above the normal range for newborn infants (>20 mU/L) and serum T_4 concentrations below the normal range (<7 $\mu\text{g/dL}$) and, thus, were clinically hypothyroid. All infants were euthyroid at 14 days after birth.

3.2.3.3 Immunological and Lymphoreticular Effects

Dermal exposures to povidone-iodine have produced localized and systemic allergic responses in humans. In one case, an adult male developed a reaction to application of povidone-iodine to an arm wound. The reaction consisted of itching of the extremities, urticaria, and angioedema (of the face), which were ameliorated with antihistamine treatment (López Sáez et al. 1998). A serum specific IgE assay detected reactivity in the patient's serum to various povidone-iodine and various other iodine preparations. Several case reports have been published that describe dermatitis in people who have been exposed to topical applications of povidone-iodine and subsequently reacted to dermal challenge tests to povidone-iodine (Okano 1989; Tosti et al. 1990).

Intravaginal applications of povidone-iodine have also induced allergic reactions in humans. In one case, an adult woman developed a bronchospastic reaction in response to application of povidone-iodine and an iodine-containing contrast medium (Moneret-Vautrin et al. 1989). The patient reacted in a dermal challenge test to povidone-iodine, but not the contrast medium, and the patient's serum tested positive for histamine release and basophil degranulation *in vitro*. In another case, anaphylaxis occurred in a patient after an intravaginal application of povidone-iodine. The patient reacted to povidone-iodine in a dermal challenge test (Waran and Munsick 1995).

Although the above cases appear to implicate povidone-iodine as the causative agent in the allergic responses reported, povidone itself, without iodine, has also been shown to produce allergic reactions and anaphylaxis in humans and may have contributed to the reactions observed in some of these cases (Garijo et al. 1996).

3. HEALTH EFFECTS

3.2.3.4 Neurological Effects

No information was located on neurological effects associated with dermal exposure to iodine. Dermal exposure to excess iodine may produce mild transient hypothyroidism and hyperthyroidism (see Section 3.2.3.2, Endocrine Effects), which could give rise to neurological manifestations of thyroid gland dysfunction including impairments in neurological development and myopathies (Boyages 2000a, 2000b). However, based on the mild effects that have been observed in association with dermal exposures, such severe neurological sequelae are not likely.

3.2.3.5 Reproductive Effects

No information was located on reproductive effects associated with dermal exposure to iodine. Dermal exposure to excess iodine may produce mild transient hypothyroidism and hyperthyroidism (see Section 3.2.3.2, Endocrine Effects). Either could give rise to disruption of reproductive systems secondary to thyroid gland dysfunction; however, based on the mild effects that have been observed in association with dermal exposures, significant disruptions of reproductive function are not likely. Hypothyroidism can produce changes in the menstrual cycle in humans, including menorrhagia (excessive uterine bleeding) and anovulation (no ovulation). Abortions, stillbirths, and premature births have also been associated with hypothyroidism (Longcope 2000a). Reproductive impairments associated with hyperthyroidism include amenorrhea, and alterations in gonadotropin release, sex hormone-binding globulin (SHBG), and associated changes in the levels and metabolism of steroid hormones in both females and males (Longcope 2000b).

3.2.3.6 Developmental Effects

No information was located on developmental effects associated with dermal exposure to iodine. Dermal exposure to excess iodine may produce mild transient hypothyroidism and hyperthyroidism (see Section 3.2.3.2, Endocrine Effects). Use of povidone-iodine for topical disinfection and surgical wound disinfection in infants has been shown to induce hypothyroidism and hyperthyroidism, and topical application of povidone-iodine during labor has been found to produce thyroid gland suppression in newborns (see Section 3.2.3.2, Endocrine Effects). Hypothyroidism or hyperthyroidism could give rise to developmental effects secondary to thyroid gland dysfunction (Boyages 2000a, 2000b). Developmental effects of hypothyroidism include severe impairment in neurological development of the fetus known as cretinism, or growth retardation (Boyages 2000a, 2000b; Snyder 2000a). Severe impairment of neurological development or growth retardation are effects only seen with severe, long-standing thyroid deficiency, not the transient form that has been associated with dermal iodine-induced hypothyroidism. Growth acceleration may occur in childhood hyperthyroidism, which is thought to be related to accelerated

3. HEALTH EFFECTS

pituitary growth hormone turnover or a direct effect of thyroid hormone on bone maturation and growth (Snyder 2000b).

3.2.3.7 Cancer

No information was located on cancer in association with dermal exposure to iodine.

3.2.4 External Exposure

No information was located on health effects associated with external exposure to radioiodine.

3.2.4.1 Death

3.2.4.2 Systemic Effects

3.2.4.3 Immunological and Lymphoreticular Effects

3.2.4.4 Neurological Effects

3.2.4.5 Reproductive Effects

3.2.4.6 Developmental Effects

3.2.4.7 Cancer

3.2.5 Other Routes of Exposure

3.3 GENOTOXICITY

Potassium iodide, I₂, and povidone iodine (0.1–10 mg/mL) did not show mutagenic effects in L5178Y mouse lymphoma cells or in transforming activity in Balb/c 3T3 cells grown in culture (Kessler et al. 1980; Merkle and Zeller 1979). Potassium iodide and I₂ did not produce lethal mutations in *Drosophila melanogaster* when eggs were incubated in 0.38 mg/mL I₂ or 0.75 mg/mL potassium iodide (Law 1938). I₂ did not show mutagenic activity in His⁺ revertant assay in *Saccharomyces cerevisiae* (Mehta and von Borstel 1982a). Iodide is a free-radical scavenger and has been shown to decrease hydrogen peroxide-induced reversion in strain TA104 of *Salmonella typhimurium* (Han 1992).

Sodium iodate (NaIO₃) was not mutagenic when tested in the bacterial Ames assay, mouse bone marrow micronucleus test, or recessive lethal test in *Drosophila melanogaster* (Eckhardt et al. 1982). Sodium iodate does have radiosensitizing activity and has been shown to increase the number of gamma radiation-induced single-strand DNA breaks in bacteria (Myers and Chetty 1973). Iodate is more active radiosensitizing agent than is iodide (Kada 1970; Kada et al. 1970; Noguti et al. 1971)

3. HEALTH EFFECTS

Chromosome aberrations (breakages, dicentrics, micronuclei) have been found in peripheral blood cells of patients who received ^{131}I ablative therapy for hyperthyroidism, in infants born to mothers who received such therapy during pregnancy, and in children exposed to radioiodine released from the Chernobyl nuclear power plant (Ardito et al. 1987; Baugnet-Mähieu et al. 1994; Boyd et al. 1974; Catena et al. 1994; Goh 1981; Lehmann et al. 1996; Ramírez et al. 1997). The range of ^{131}I exposures in these cases was 15–200 mCi (0.6–7.4 GBq).

A study of 21 patients who received various exposures to ^{131}I for ablative treatment of thyroid carcinoma found a significantly higher frequency of micronuclei in peripheral blood cells of patients compared to a group of 93 healthy controls (Catena et al. 1994). A significant exposure response relationship was observed at exposures that ranged from 35 to 202 mCi (1.3–7.5 GBq). A study of 10 patients who received ^{131}I for ablative treatment of thyroid carcinoma compared the outcomes of cytogenetic assessment of peripheral blood lymphocytes before or 1 and 10 days after their ^{131}I exposures (Baugnet-Mahieu et al. 1994). The patients received two oral doses of 840 MBq (50 mCi) given on 2 consecutive days. A small but statistically significant increase in “abnormal cells” (2.69%) and dicentrics (1.91%) occurred after exposure to ^{131}I . Cytogenetic assessments of peripheral blood lymphocytes of five patients who received 15–40 mCi (0.6–1.6 GBq) for treatment of hyperthyroidism and four control subjects revealed dicentrics and rings in the treated patients, but no such abnormalities in the control subjects (Boyd et al. 1974). An increase in the frequency of micronuclei in peripheral blood lymphocytes was observed of 12 adult women 1 week after they received 100–150 mCi ^{131}I (3.7–5.5 GBq) for treatment of thyroid cancer (Ramírez et al. 1997). The frequency of chromosome translocations in thyroid tumor tissue was compared among groups of patients who had tumors but no radiation history (n=24), patients who received ^{131}I or external radiation therapy (n=7), and children (n=40) who were residents of the Gomel, Brest, or Minsk regions of Belarus at the time of the Chernobyl accident (Lehmann et al. 1996). The frequency of translocations was highest in the patients who received radiation therapy and lowest in the patients that had no history of exposure to radiation. Translocation frequencies among Belarussian children were lower than in the radiation therapy patients and higher than the patients who had no radiation history. The highest translocation frequencies among Belarussian children were observed in children from the Gomel region where ^{131}I exposures and thyroid radiation doses are considered to have been the highest of the three regions studied.

Goh (1981) reported a case of cretinism that developed at age 8 months in an infant whose mother received 99 mCi (3.7 GBq) of ^{131}I during her sixth week of pregnancy. The infant was hypothyroid and had no detectable thyroid gland function. Cytogenetic studies conducted on peripheral blood lymphocytes revealed chromosomal breakages in both the infant and mother.

3. HEALTH EFFECTS

3.4 TOXICOKINETICS**3.4.1 Absorption****3.4.1.1 Inhalation Exposure**

Molecular iodine (I₂) is absorbed when humans are exposed to I₂ vapor. In volunteers who inhaled radioiodine I₂ vapor, essentially all of the inhaled vapor was retained and cleared from the respiratory tract with a half-time of approximately 10 minutes (Black and Hounam 1968; Morgan et al. 1968). Much of the clearance of the iodine from the respiratory tract was transferred to the gastrointestinal tract, suggesting that the initial deposition was primarily in the conducting airways and subject to mucocilliary clearance mechanisms. Observations in humans of relatively rapid absorption of inhaled I₂ are supported by studies in mice, rats, dogs, and sheep (Bair et al. 1963; Willard and Bair 1961).

Methyl iodide is also inhaled when humans are exposed to methyl iodide vapor. In volunteers who inhaled tracer concentrations of [¹³²I]methyl iodide, approximately 70% of the inhaled iodine was retained with a half-time in the respiratory tract of approximately 5 seconds, suggesting extremely rapid absorption at the alveolar-blood interface (Morgan and Morgan 1967; Morgan et al. 1967a, 1967b).

Studies of the absorption of inhaled inorganic iodide in humans are not available. However, in monkeys that inhaled particulate aerosols of radioiodine as sodium iodide (mass median diameter, 2.32 μm±1.15 SD), inhaled iodide was retained in the respiratory tract with a half-time of approximately 10 minutes (Perrault et al. 1967; Thieblemont et al. 1965). In dogs and rats that were exposed to cesium chloride aerosols containing ¹³¹I (mass median aerodynamic diameter, 1.4 μm±1.7 SD), iodine was retained and rapidly cleared from the respiratory tract (McClellan and Rupprecht 1968; Thomas et al. 1970). Retention and relatively rapid absorption of iodine has also been observed in mice and sheep that inhaled radioiodine as either sodium iodide or silver iodide particulate aerosols (mean count diameter, 0.25 μm) (Bair et al. 1963; Willard and Bair 1961).

3.4.1.2 Oral Exposure

Gastrointestinal absorption of iodine is generally considered to be approximately 100% after an ingested dose of water soluble iodide salts, such as potassium or sodium iodide. This conclusion is based on several types of observations made in human subjects who received oral doses of radioiodine compounds (the reader should note that where the chemical form of the radioiodine compound was not reported, which is the case for most of the radioiodine tracer studies described here, it is likely that it was sodium iodide, as this is a common form supplied commercially for pharmaceutical use). Fecal excretion of ¹³¹I was <1% of

3. HEALTH EFFECTS

the dose in seven euthyroid adult subjects who ingested a single tracer dose of ^{131}I , suggesting near complete absorption of the ingested radioiodine (Fisher et al. 1965). In the same study, 20 euthyroid adults received daily oral doses of potassium iodide for 13 weeks (0.25 or 1.0 mg I/day). Daily urinary iodine excretion was approximately 80–90% of the estimated daily intake, also suggesting near complete absorption. Similarly, in an acute ingestion study of nine healthy subjects, urinary and thyroid radioiodine accounted for 97% (± 5 , SD) of a single ingested tracer dose of radioiodine (^{131}I or ^{132}I), suggesting near complete absorption of the tracer dose (Ramsden et al. 1967). In this same study, two subjects ingested the tracer dose together with a dose of 5 or 15 mg stable iodide (the chemical form of the stable iodide was not specified, but presumably, it was either potassium or sodium iodide) and the recoveries of radioiodine in thyroid and urine were 96 and 98%, respectively. In one subject who ingested the tracer dose either after a fast (duration not specified) or with a “full stomach”, the recoveries of radioiodine in thyroid and urine were 97 and 98% under the two conditions (Ramsden et al. 1967).

Measurement of radioiodine uptake in the thyroid gland is also an indicator of absorption, although such measurements alone do not allow an accurate quantitative estimate of absorption without other assumptions about the pharmacokinetics of iodine. Studies of iodine kinetics in subjects who received intravenous injections of tracer doses of radioiodine have shown that the fraction of an injected dose that accumulates in the thyroid is affected by many variables; however, it is relatively constant among individuals who have the same iodine intake and whose thyroid glands are “normal” (see Section 3.4.2.2). This fraction has been shown to be similar (20–35%) when radioiodine (^{123}I , ^{125}I , or ^{131}I) is administered to adults by the intravenous or oral routes, suggesting extensive, if not complete, absorption of ingested radioiodine (Bernard et al. 1970; Gaffney et al. 1962; Ghahremani et al. 1971; Oddie and Fisher 1967; Pittman et al. 1969; Robertson et al. 1975; Sternthal et al. 1980; Van Dilla and Fulwyler 1963, 1964). Although the fraction of the oral dose of radioiodine taken up by the thyroid 1–2 days after an oral dose may be slightly higher in females than males, there is no evidence that this difference results from differences in absorption (Ghahremani et al. 1971; Quimby et al. 1950; Robertson et al. 1975).

Gastrointestinal absorption of iodine appears to be similar in children, adolescents, and adults, as assessed from measurements of 24-hour thyroid uptakes of radioiodine administered orally (Cuddihy 1966; Oliner et al. 1957; Van Dilla and Fulwyler 1963, 1964). Absorption in infants, however, may be lower than in children and adults. Evidence for this comes from studies in which thyroid uptake of radioiodine was measured in newborns who received tracer doses of radioiodine orally or by injection. In general, injection of the radioiodine intramuscularly or intravenously resulted in higher thyroid uptakes than when the radioiodine was administered by gastric tube, suggesting incomplete absorption of the oral dose. For example, in 8 healthy newborn infants (<36 hours post natal) who each received a tracer dose of ^{131}I by gastric tube, the average peak thyroid uptake (30 hours after the dose) was approximately 50% of the dose compared to an average of 70% (25 hours after the dose) in 17 infants who received the tracer dose as an

3. HEALTH EFFECTS

intramuscular injection (Morrison et al. 1963). The ratio of the thyroid uptakes after the oral and injected iodine doses suggests a fractional oral absorption of approximately 70%. In a study involving slightly older newborns (72–96 hours old), 15 newborns each received a tracer dose of ^{131}I by gastric tube and the average 24-hour uptake of radioiodine in the thyroid was 20% (range, 6–35%) (Ogborn et al. 1960). By contrast, in a study of seven healthy infants (<3 days old), the mean thyroid uptake 24 hours after an intramuscular tracer dose of ^{131}I was 70% (range, 46–97) (van Middlesworth 1954). In a study of 26 healthy newborns (<48 hours old) who each received an intravenous tracer dose of ^{131}I , the mean 24-hour thyroid uptake was 62% (range, 35–88) (Fisher et al. 1962). Some of the differences in the thyroid uptakes observed in the above three studies may reflect differences in age, as thyroid uptake of injected radioiodine appears to decrease substantially during the first postnatal week (see Section 3.4.2.2); nevertheless, the studies suggest the possibility of lower absorption of iodine (30–70% of an oral dose) during the first few postnatal days, which may extend to older ages of infancy.

Although ingested iodide appears to be nearly completely absorbed in children and adults (but not in infants), other chemical forms of iodine appear to be less completely absorbed. For example, iodine compounds, such as I_2 and iodates (e.g., NaIO_3), may undergo reduction to iodide before being absorbed in the small intestine and absorption may not be complete (Cohn 1932). Iodine from the sodium salt of the thyroid hormone thyroxine (T_4) is absorbed when T_4 is ingested. In two adults who each received a single oral dose of $80 \mu\text{g } [^{131}\text{I}]\text{-T}_4$, the rate of fecal excretion of radioiodine was similar to that observed in three subjects who received the same dose intravenously (10–15% of the dose), suggesting substantial absorption from the gastrointestinal tract (Myant and Pochin 1950). In this same study, the sum of urinary excretion of radioiodine and thyroid uptake of radioiodine, 24 hours after the oral dose of $[^{131}\text{I}]\text{-T}_4$ was approximately 25% of the dose, compared to an average of 33% (± 7) in six subjects who received the $[^{131}\text{I}]\text{-T}_4$ dose intravenously. This observation is also consistent with substantial, if not complete, absorption of T_4 from the gastrointestinal tract (at least 75% of the dose).

Iodine incorporated into bovine milk appears to be nearly completely absorbed when ingested. Cuddihy (1966) measured thyroid uptakes of radioiodine in euthyroid subjects who ingested radioiodine-contaminated cow milk for 14 days. The milk was collected from a cow that was fed ^{131}I in feed (endogenously incorporated). Thyroid uptake 24 hours after the last milk dose was approximately 23% of the dose. Since this value is within the range of 20–35% observed when a tracer dose of ^{131}I was administered orally or intravenously, it suggests that iodine that is endogenously incorporated into cow milk is extensively, if not completely, absorbed. A slightly different observation leads to a similar conclusion. Comar et al. (1963) compared radioiodine uptakes in each of 11 healthy adults who ingested ^{131}I in a capsule (containing an aqueous solution of radioiodine) or ^{131}I endogenously incorporated into cow milk. The 24-hour thyroid uptakes were nearly identical under each dosing condition (means, 19 and 20% of the dose) suggesting a similar absorbed fraction of the dose. Pendelton et al. (1963) measured ^{131}I in

3. HEALTH EFFECTS

dairy cow milk from farms near the NTS, and in the thyroids or total bodies of families who lived on these farms (measured from external thyroid or total body counting). The average uptake of ^{131}I in 24 individuals was 17% (range, 5–47%) which is similar to that observed after ingestion or injection of radioiodine. Assessments of gastrointestinal absorption of iodine in other foods are not available, although Wayne et al. (1964) reported that radioiodine incorporated into watercress was completely absorbed when ingested by an adult (no details provided).

Observations in humans that indicate extensive absorption of ingested inorganic iodine are supported by experiments in animals. Iodine is extensively absorbed in rats when it is ingested as either I_2 or NaI . When fasted rats were administered oral gavage tracer doses of ^{131}I as either I_2 or NaI , 8–9% of the dose was excreted in feces in 72 hours and 34–35% of the dose was excreted in the urine (Thrall and Bull 1990). In the same study, similar results were obtained in rats that were allowed free access to food before the oral radioiodine dose; 6–7% of the dose was excreted in feces in 78 hours and 22–29% was excreted in urine (22% of the I_2 dose and 29% of the NaI dose). These results suggest that tracer doses of ingested iodine from NaI and I_2 are both nearly completely absorbed from the gastrointestinal tract in rats. When tracer levels of radioiodine (^{131}I) were administered orally, intravenously, or subcutaneously to four sheep, the peak thyroid uptake of radioiodine was similar, 17–19% of the dose (these values are not corrected for radioactive decay of the ^{131}I), suggesting extensive absorption from the oral route (Wood et al. 1963).

Povidone-iodine is a complex of I_2 and polyvinyl pyrrolidone that is widely used as topical antiseptic. Povidone-iodine preparations contain approximately 9–12% iodine, of which only a small fraction is free in solution (Lawrence 1998; Rodeheaver et al. 1982). Absorption of iodine ingested as povidone-iodine has been studied in rats. Rats that received single gavage doses of ^{125}I -povidone (dose not specified) absorbed approximately 3% of the dose, as assessed by measurements of the radioiodine that was retained in the gastrointestinal tract 24 hours after the dose (Abdullah and Said 1981). In the same study, absorption was approximately 10 or 5% when the povidone-iodine was administered in 10% ethanol solution and 5% when administered as a 0.2% solution of benzalkonium chloride.

3.4.1.3 Dermal Exposure

Systemic iodine toxicity has occurred following dermal exposures to iodine compounds, suggesting that these compounds of iodine are absorbed across the skin of humans (see Section 3.2.3). Harrison (1963) attempted to estimate absorption rates for solutions of potassium iodide or iodine (I_2), and gaseous I_2 in humans. Subjects received topical applications of ^{131}I as potassium iodide or iodine (I_2) and absorption was estimated from measurements of the cumulative urinary excretion of radioactivity and the 24-hour activity in the thyroid. Three subjects received a topical application of tracer concentrations of ^{131}I -KI on a 12.5 cm^2 area of the forearm. The site was left uncovered and after 2 hours, all of the applied

3. HEALTH EFFECTS

radioactivity could be detected on the skin and approximately 90% of the radioactivity could be recovered from the skin by washing with soap and water. Absorption was estimated to be approximately 0.1% of the applied dose (range, 0.09–0.13) based on 3-day cumulative urine radioactivity. Thyroid radioactivity 24-hours after the topical dose was below the limits of detection. If it was assumed that the 24-hour thyroid uptake was 30% of the absorbed dose and that the all of the absorbed activity that was not recovered in urine was in the thyroid, absorption was approximately 0.16% in the three subjects (range, 0.13–0.19). In two subjects in this same study who received a similar topical application of aqueous tracer [^{131}I] I_2 along with 0.1 mg of [^{127}I] I_2 carrier, the absorption was estimated to be 0.06–0.09% of the applied dose, with the higher estimate assuming thyroid uptake of 30% of the absorbed dose. This study also estimated iodine absorption after dermal exposure to [^{131}I] I_2 vapor. When a 12.5 cm² area of skin was isolated and placed in contact with I_2 vapor for 30 minutes or 2 hours, approximately 90% of the total iodine content of the vapor was deposited on the skin. Approximately 50% of the deposited dose could be washed off with soap and water. Absorption varied depending on the amount of [^{127}I] I_2 carrier in the vapor (the concentration was not reported). At the lowest carrier amount (approximately 0.8 mg applied to the skin), absorption of ^{131}I was 1.2% of the activity that was on the skin at the end of the 2-hour exposure. With exposure to 3–5 mg carrier, which produced visible irritation of the skin (reddening or blistering), absorption was 27–78%. These observations suggest that exposure to I_2 vapors can result in deposition of iodine onto the skin and that dermal irritation produced by I_2 , and possibly other irritants, may substantially increase the absorption of iodine after dermal exposure to I_2 . Dermal absorption of I_2 vapor was indicated an experimental study in which ^{131}I was detected in the thyroid glands of seven male adult volunteers who were exposed, whole body and without respiratory intake, to $^{131}\text{I}_2$ vapor (the exposure appears to have been to tracer levels) for up to 4 hours (Gorodinskiy et al. 1979).

Povidone-iodine, a complex with iodine and polyvinyl-pyrrolidone, and alcohol tinctures of iodine are widely used as a topical antiseptic. Iodine is absorbed to some extent when such preparations are applied to the skin, although quantitative estimates of the amount absorbed are not available for humans. Urinary iodine excretion has been shown to increase following the topical application of povidone-iodine to the hands and arms as part of a surgical scrub routine, indicating systemic absorption (Connolly and Shepard 1972). Increases in iodine concentration in maternal urine and umbilical cord blood have been observed in pregnant women who received dermal or vaginal applications of povidone-iodine prior to delivery for disinfection of the skin and fetal scalp electrodes, suggesting that absorption of iodine occurs with these uses of povidone-iodine as well (l'Allemand et al. 1983; Bachrach et al. 1984). Thyroid enlargement, hypothyroidism, and elevated urinary iodine excretion also have been observed in hospitalized infants who received frequent topical antiseptic scrubs with iodine-alcohol preparations as part of preparations for various clinical procedures (Brown et al. 1997; Chabrolle and Rossier 1978a, 1978b).

3. HEALTH EFFECTS

Some quantitative information is also available on dermal absorption of iodine in animals. When tracer levels of radioiodine (^{131}I) were applied to the shaved skin ($50\text{--}100\text{ cm}^2$) of four sheep, the peak thyroid uptake of radioiodine was 2–6% of the applied dose compared to 17–19% when the dose was given orally, subcutaneously, or intravenously (these values are not corrected for radioactive decay of the ^{131}I) (Wood et al. 1963). In a second study, two sheep received a tracer dose of radioiodine as either an oral dose or a topical dose; the peak thyroid uptake was 9–14% of the dose at 48–96 hours after the topical dose, compared to 30% at 48 hours after the oral dose (both values corrected for radioactive decay). The report of these studies does not specify whether the topical applications were occluded or whether the animals were restrained in any way from ingesting the topically applied radioiodine (e.g., licking the site of application). If ingestion of the radioiodine did not occur, then these studies suggest substantial absorption of topically applied iodine since, during the first 1–4 days after topical dosing, thyroid radioiodine uptake was approximately 30–50% of that observed after oral dosing, and thyroid uptakes after oral and parenteral dosing were similar.

Additional evidence for dermal absorption of iodine comes from a study of pigs. A solution (solvent not specified) containing a mixture of 85% $^{131}\text{I}I_2$ and 15% $^{131}\text{I}NaI$ was applied to a 150 cm^2 area of abdominal skin on each of four immature pigs and allowed to dry on the skin; the site of application was not covered and it is not clear if the site was accessible to licking and ingestion of the applied radioiodine (Murray 1969). Approximately 95% of the applied dose was removed from the skin by washing the site of application 2 hours after the dosing. Peak thyroid uptake of radioiodine was approximately 0.2% of the dose, 1–2 days after dosing (the report does not indicate whether the radioiodine measurements were corrected for radioactive decay). In the same study, a 150 cm^2 area of clipped flank skin on each of four immature pigs was exposed for 25 minutes to a vapor of ^{131}I containing 85% gaseous ^{131}I , presumably $^{131}\text{I}I_2$. The exposed areas were not covered or washed subsequent to exposure. Peak thyroid uptake of radioiodine was approximately 0.3% of the applied dose 5–7 days after dosing. The lower amount of absorption of radioiodine in the pigs compared to the results obtained in sheep (Wood et al. 1963) cannot be interpreted with the available information. It may reflect species differences in skin permeability to iodine, differences in the chemical form iodine applied to the skin (I_2 or I^-), or differences in the amounts of topically-applied radioiodine that were ingested from licking the site of application.

Povidone-iodine, an ingredient of some iodine-based topical disinfectants, is absorbed across the skin of dogs. Topical application of povidone-iodine in dogs resulted in elevated serum iodide concentrations within 2 hours after application; the amount of iodine absorbed was not determined in this study (Moody et al. 1988). Evidence for absorption of iodine from topically applied povidone-iodine is also provided by experiments with rats and mice. Topical application of povidone-iodine to $15\text{--}20\text{ mm}^2$ of the shaved skin of either rats or mice 2 hours prior to an injection of radioiodine decreased radioiodine uptake in the

3. HEALTH EFFECTS

thyroid by 90%, suggesting competition between the absorbed topically applied iodine and the injected radioiodine for thyroid uptake (Furudate et al. 1997).

3.4.1.4 Other Routes of Exposure

Iodine is absorbed systemically after intravaginal applications of povidone-iodine. Increases in iodine concentration in maternal urine, umbilical cord blood, and breast milk, and in infant urine have been observed following vaginal applications of povidone-iodine to pregnant women prior to delivery for disinfection of fetal scalp electrodes (l'Allemand et al. 1983).

3.4.2 Distribution

3.4.2.1 Inhalation Exposure

The distribution of absorbed iodine is expected to be similar regardless of the route of exposure to inorganic iodine. This is supported by studies in which humans were exposed to tracer levels of [¹³²I]CH₃I and approximately 20–30% of the iodine retained in the respiratory tract was distributed to the thyroid gland and 30–60% was excreted in urine in approximately 10 hours; essentially identical results were obtained when a tracer dose of ¹³²[I]NaI was ingested (Morgan et al. 1967a, 1967b). Similar results were obtained when volunteers inhaled tracer levels of radioiodine as I₂ (Black and Hounam 1968; Morgan et al. 1968). The distribution of inhaled particulate aerosols of sodium iodide in monkeys also appears to be similar to ingested iodide (Perrault et al. 1967; Thieblemont et al. 1965). A complete discussion of the distribution of iodine after oral exposures to inorganic iodine is presented in Section 3.4.2.2, and is applicable to inhalation exposures.

3.4.2.2 Oral Exposure

The human body contains approximately 10–15 mg of iodine, of which approximately 90% is in the thyroid gland, which accumulates iodine in producing thyroid hormones for export to the blood and other tissues (Cavalieri 1997; Stather and Greenhalgh 1983). The concentration of iodine in serum is approximately 50–100 µg/L under normal circumstances (Fisher et al. 1965). Approximately 5% in serum is in the inorganic form as iodide; the remaining 95% consists of various organic forms of iodine, principally protein complexes of the thyroid hormones T₄ and T₃ (Fisher et al. 1965; Nagataki et al. 1967; Sternthal et al. 1980; Wagner et al. 1961).

The tissue distribution of iodide and organic iodine are very different and are interrelated by metabolic pathways that lead to the iodination and deiodination of proteins and thyroid hormones in the body (see

3. HEALTH EFFECTS

Section 3.4.3.2). Iodide is largely confined to the extracellular fluid compartment, with the exception of tissues that possess specialized transport mechanisms for accumulating iodide; these include the thyroid, salivary glands, gastric mucosa, choroid plexus, mammary glands, placenta, and sweat glands (Brown-Grant 1961) (see Section 3.4.1). Serum concentrations of iodide, indicative of extracellular fluid concentrations, normally range from 5 to 15 $\mu\text{g/L}$; this would suggest a total extracellular iodide content of the human body of approximately 85–170 μg , assuming an extracellular fluid volume of approximately 17 L (Cavalieri 1997; Saller et al. 1998).

Iodide concentrations in the thyroid are usually 20–50 times that of serum (0.2–0.4 mg/dL, 15–30 nM); however, concentrations in excess of 100 times that of blood occur when the gland is stimulated by thyrotrophin (a TSH) and concentrations in excess of 400 times blood have been observed (Wolff 1964). Other tissues that can accumulate iodide to a concentration greater than that of blood or serum include the salivary glands, gastric mucosa, choroid plexus, mammary glands, placenta, and sweat glands (Brown-Grant 1961). Iodide taken up by the thyroid gland is utilized in the production of thyroid hormones, which are stored in the gland (see Section 3.4.3.2). This organic fraction of the thyroid iodine content accounts for approximately 90% of the iodine in the thyroid gland and includes iodinated tyrosine and tyrosine residues that comprise the thyroid hormones, T_4 and T_3 , and their various synthesis intermediates and degradation products.

The thyroid hormones, T_4 and T_3 , account for approximately 90–95 and 5% of the organic iodine in plasma, respectively (Fisher et al. 1965; Sternthal et al. 1980). Nearly all (>99%) of the T_4 and T_3 in plasma is bound to protein. The major binding protein for T_4 and T_3 is thyroxine-binding globulin (TBG), which has a high affinity for both hormones (Table 3-4) (Larsen et al. 1998; Robbins 1996). Other proteins that bind thyroid hormones, with lower affinity, include transthyretin (thyroxine-binding prealbumin), albumin, and various apoproteins of the high density lipoproteins HDL₂ and HDL₃ (3–6% of plasma hormones). The distribution of protein-bound thyroid hormones is largely confined to the plasma space, whereas the free hormones distribute to the intracellular space of a wide variety of tissues where they exert the metabolic effects attributed to thyroid hormones. TBG and other binding proteins serve as reservoirs for circulating thyroid hormones and contribute to the maintenance of relatively constant free hormone concentrations in plasma.

Uptake of T_4 and T_3 into liver, skeletal muscle, and other tissues occurs by a saturable, energy-dependent carrier transport system (see Section 3.5.1). Lipoprotein transport mechanisms may also play a role in the uptake of thyroid hormones into certain tissues (Robbins 1996). Intracellular T_4 and T_3 exist as free hormone and are bound to a variety of intracellular proteins.

3. HEALTH EFFECTS

Table 3-4. Binding Characteristics of Major Human Thyroid Hormone-Binding Proteins

Parameter	Thyroxine-binding globulin	Transthyretin	Albumin
Molecular weight of complex (D)	54,000	54,000 (subunit) ^a	66,000
Plasma concentration (μmol/L)	0.27	4.6	640
T ₄ binding capacity (μg T ₄ /dL)	21	350	50,000
Association constants (M ⁻¹)			
T ₄	1x10 ¹⁰	7x10 ⁷	7x10 ⁵
T ₃	5x10 ⁸	1.4x10 ⁷	1x10 ⁵
Fraction of sites occupied by T ₄ ^b	0.31	0.02	<0.001
Distribution volume (L)	7	5.7	7.8
Turnover rate (percent/day)	13	59	5
Distribution of thyronines (percent/protein)			
T ₄	68	11	20
T ₃	80	9	11

Source: Larsen et al. 1998

^aTransthyretin consists of four subunits (54 kD) complexed with retinol binding protein

^bIn euthyroid state

T₃ = 3,5,3Ntriodo-L-thyronine; T₄ = 3,5,3N5Ntetraiodo-L-thyronine (thyroxine)

3. HEALTH EFFECTS

Maternal exposure to iodine results in exposure to the fetus. Radioiodine accumulation in the fetal thyroid commences in humans at approximately 70–80 days of gestation, and precedes the development of thyroid follicles and follicle colloid, which are generally detectable at approximately 100–120 days of gestation (Book and Goldman 1975; Evans et al. 1967). Fetal iodide uptake activity increases with the development of the fetal thyroid and reaches its peak at approximately 6 months of gestation, at which point, the highest concentrations in thyroid are achieved, approximately 5% of the maternal dose/g fetal thyroid (approximately 1% of the maternal dose) (Aboul-Khair et al. 1966; Evans et al. 1967). Fetal radioiodine concentrations 1–2 days following a single maternal dose of radioiodine generally exceed the concurrent maternal thyroid concentration by a factor of 2–8 with the highest fetal/maternal ratios occurring in at approximately 6 months of gestation (Book and Goldman 1975). Following long-term exposure, either from ingestion of administered radioiodine or from exposure to radioactive fallout, the fetal/maternal ratio for thyroid radioiodine concentration has been estimated to be approximately 2–3 (Beierwaltes et al. 1963; Book and Goldman 1975; Eisenbud et al. 1963).

Iodine uptake into the thyroid gland is highly sensitive to the iodide intake. At very low intakes, representing iodine deficiency (e.g., 20 µg/day), uptake of iodide into the thyroid gland is increased (Delange and Ermans 1996). This response is mediated by TSH, which stimulates iodide transport and iodothyronine production in the thyroid gland (see Section 3.5.1). At very high intakes of iodine, representing an intake excess (e.g., >1 mg/day), iodine uptake into the thyroid gland decreases, primarily as a result of decreased iodothyronine synthesis (Wolff-Chaikoff effect) and iodide transport into the gland (Nagataki and Yokoyama 1996; Saller et al. 1998). The fraction of an ingested (or injected) tracer dose of radioiodide that is present in the thyroid gland 24 hours after the dose has been measured in thousands of patients who received radioiodine for treatment of various thyroid disorders or for the assessment of thyroid function; these provide a comparative index of effects of various factors on the distribution of absorbed iodide to the thyroid gland. A single oral dose of 30 mg iodide (as sodium iodide) decreases the 24-hour thyroid uptake of radioiodine by approximately 90% in healthy adults (Ramsden et al. 1967; Sternthal et al. 1980). The inhibition of uptake was sustained with repeated oral doses of sodium iodide for 12 days, with complete recovery to control (presodium iodide) uptake levels within 6 weeks after the last sodium iodide dose (Sternthal et al. 1980) or within 8 days after a single dose (Ramsden et al. 1967). Repeated oral doses of 1.5–2.0 mg iodide/m³ of surface area produced an 80% decrease in thyroid uptake in children (Saxena et al. 1962).

The National Cancer Institute (NCI 1997) has analyzed data on 24-hour thyroid uptakes of radioiodine reported over the period from 1950 to 1980 and concluded that thyroid uptakes in adults have decreased in the United States over time from approximately 20–40% of the dose in the 1950–1960 period to approximately 15–20% currently (Cuddihy 1966; Dunning and Schwartz 1981; Kearns and Phillipsborn 1962; Kereiakes et al. 1972; Oddie and Fisher 1967; Oliner et al. 1957; Pittman et al. 1969; Van Dilla and

3. HEALTH EFFECTS

Fulwyler 1964). This decrease appears to be related to a concurrent increase in the average dietary intake of iodide in the population from approximately 200 µg/day to approximately 800 µg/day (NCI 1997).

Twenty-four-hour radioiodine uptakes into the thyroid gland in males and females who experience similar iodide intakes are similar, although uptakes in females, as a percentage of the dose, appear to be 10–30% higher than in males (Ghahremani et al. 1971; Oddie et al. 1968a, 1970; Quimby et al. 1950; Robertson et al. 1975). Thyroid uptakes in newborns are 3–4 times greater during the first 10 days of postnatal life than in adults, and decline to adult levels after approximately age 10–14 days (Fisher et al. 1962; Kearns and Phillipsborn 1962; Morrison et al. 1963; Ogborn et al. 1960; Van Middlesworth 1954).

3.4.2.3 Dermal Exposure

The distribution of absorbed iodine is expected to be similar regardless of the route of exposure to inorganic iodine. A complete discussion of the distribution of iodine after oral exposures to inorganic iodine is presented in Section 3.4.2.2, and is applicable to inhalation exposures.

3.4.2.4 Other Routes of Exposure

The distribution of absorbed iodine is expected to be similar regardless of the route of exposure to inorganic iodine. A complete discussion of the distribution of iodine after oral exposures to inorganic iodine is presented in Section 3.4.2.2, and is applicable to inhalation exposures.

3.4.3 Metabolism

3.4.3.1 Inhalation Exposure

The metabolism of absorbed iodine is expected to be similar regardless of the route of exposure to inorganic iodine. Inhaled methyl iodide and I₂ appear to undergo rapid conversion to iodide based on nearly identical distribution and excretion kinetics of radioiodine when it is inhaled as either methyl iodide or I₂, or ingested as sodium iodide (Black and Hounam 1968; Morgan and Morgan 1967; Morgan et al. 1967a, 1967b, 1968). A complete discussion of the metabolism of iodine after oral exposures to inorganic iodine is presented in Section 3.4.3.2, and is applicable to inhalation exposures.

3. HEALTH EFFECTS

3.4.3.2 Oral Exposure

Iodide in the thyroid gland is incorporated into a protein, thyroglobulin, as covalent complexes with tyrosine residues (Figure 3-3). The iodination of thyroglobulin is catalyzed by the enzyme thyroid peroxidase, which resides predominantly in the apical membrane of thyroid follicle cells, with the active sites of the enzyme facing the follicular lumen (see Section 3.4.1). The iodination reactions occur at the follicular cell-lumen interface and consist of the oxidation of iodide to form a reactive intermediate, the formation of monoiodotyrosine and diiodotyrosine residues in thyroglobulin, and the coupling of the iodinated tyrosine residues to form T_4 (coupling of two diiodotyrosine residues) or T_3 (coupling of a monoiodotyrosine and diiodotyrosine residue) in thyroglobulin (Figure 3-4). The T_4/T_3 ratio in the thyroid is approximately 15:1; however, the relative amounts of T_4 and T_3 produced depend, in part, on the availability of iodide. Low levels of iodide result in a lower T_4/T_3 synthesis ratio (Taurog 1996).

Thyroglobulin is stored in the follicular lumen. When the thyroid gland is stimulated to produce and release thyroid hormones, thyroglobulin is transported into the follicular cells (Taurog 1996). Uptake of thyroglobulin occurs by endocytosis at the apical membrane, which is followed by fusion of endocytotic vesicles with lysosomes. Proteolytic enzymes in the lysosomes break down the thyroglobulin into constituent amino acid residues, including T_4 , T_3 , monoiodotyrosine, and diiodotyrosine. T_4 and T_3 are exported to the blood, while monoiodotyrosine and diiodotyrosine residues are retained in the cell and deiodinated, and the iodide is recycled into the follicular lumen where it is reincorporated into thyroglobulin. Under circumstances of extreme stimulation of the thyroid gland, monoiodotyrosine, diiodotyrosine, and iodide can be released into the blood from the gland along with T_4 and T_3 . Although the T_4/T_3 ratio in thyroglobulin is approximately 15:1 in the iodide replete state, the hormone secretion ratio is lower, approximately 10:1; thus, some T_4 appears to undergo monodeiodination to T_3 in the thyroid gland.

All of the major steps of thyroid hormone synthesis and release are stimulated by the pituitary hormone, TSH, including uptake of iodine by the thyroid gland, iodination of thyroglobulin, endocytosis of thyroglobulin from the follicle lumen, and proteolysis of thyroglobulin to release thyroid hormone for export to blood (see Section 3.4.1). Hormone synthesis is also responsive to serum iodide concentration. An acute exposure to high oral doses of iodide (e.g., >1 mg) inhibits the production of iodothyronine in the thyroid gland; this effect is not dependent on changes in circulating TSH levels, and is referred to as the Wolff-Chaikoff effect (Wolff and Chaikoff 1948). The effect is temporary, and with repeated exposure to high doses of iodide, the thyroid gland escapes from the Wolff-Chaikoff effect and hormone synthesis resumes to normal levels (Wolff et al. 1949). The mechanism for the Wolff-Chaikoff effect appears to involve inhibition of both iodide transport and iodination reactions, possibly through an inhibition of the expression of NIS and thyroid peroxidase that is mediated by iodide or an iodinated metabolic intermediate

3. HEALTH EFFECTS

Figure 3-3. Pathways Uptake and Metabolism of Iodide in the Thyroid Gland

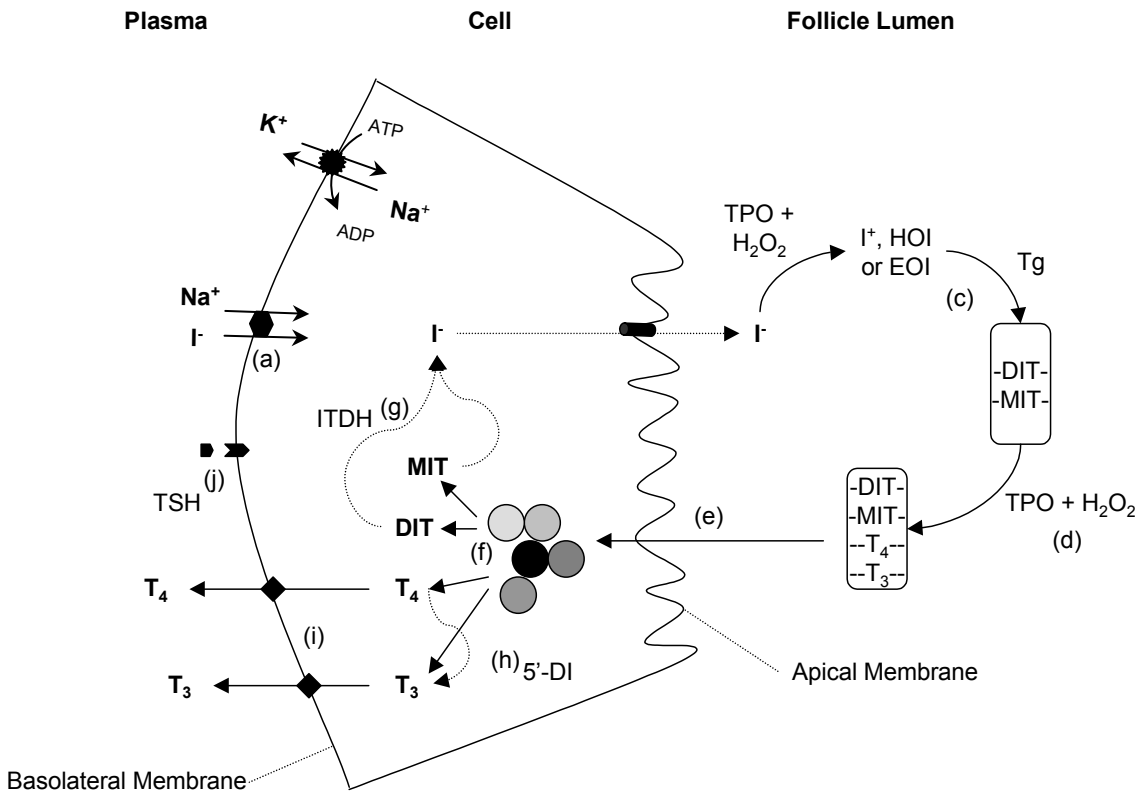

<u>METABOLIC STEP</u>	<u>INHIBITOR</u>
a. Iodine uptake	ClO_4^- , SCN^- , I^-
b. Iodine efflux	
c. Iodination	PTU, MMI
d. Coupling	PTU, MMI
e. Colloid resorption	Colchicine, Li^{2+} I^- , Cytoclasin B
f. Proteolysis	I^-
g. Deiodination of DIT and MIT	Diiodotyrosine
h. Deiodination of T_4	PTU
i. Secretion of T_3 and T_4	
j. TSH receptor binding	

The diagram depicts a single thyroid follicle cell, with the plasma side of the follicle on the left and the follicle lumen on the right. Iodide uptake (a) occurs through a Na^+/I^- symporter in the basolateral membrane and efflux into the follicle lumen (b) is thought to occur through an I^- channel in the apical membrane. Iodination occurs in the follicle lumen (c). The enzyme thyroid peroxidase (TPO), depicted in the follicle lumen, is actually located in the apical membrane. Deiodination of iodotyrosines (g) is catalyzed by a microsomal enzyme, iodotyrosine dehalogenase (ITDH); monodeiodination of T_4 (h) is catalyzed by the microsomal enzyme, 5'-diodinase. All steps in the uptake of iodine and synthesis of thyroid hormones (a - h) are stimulated by binding of thyroid stimulating hormone (TSH) to a receptor in the basolateral membrane. Abbreviations: DIT, diiodotyrosine; EOI, enzyme-linked species; HOI, hypoidous acid; ITDH, iodotyrosine dehalogenase; MMI, methimazole; MIT, monoiodotyrosine; PTU, propylthiouracil; T_3 , triiodothyronine; T_4 , thyronine; Tg, thyroglobulin; TPO, thyroid peroxidase; TSH, thyroid stimulating hormone.

Source: Taurog 2000

Figure 3-4. Thyroid Hormones and Metabolic Precursors

Thyronine

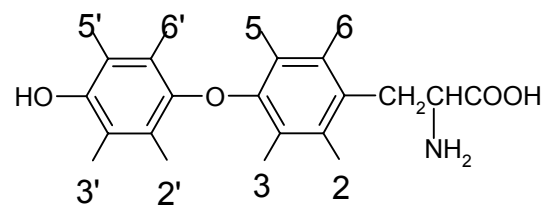

3,5,3',5'-Tetraiodothyronine (thyroxine, T₄)

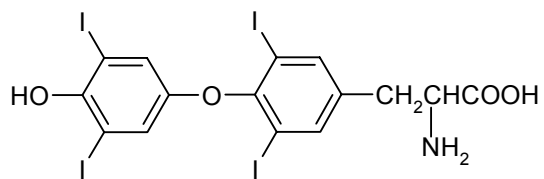

3,5,3'-Triiodothyronine (T₃)

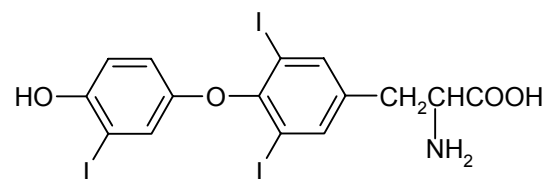

Diiodotyrosine

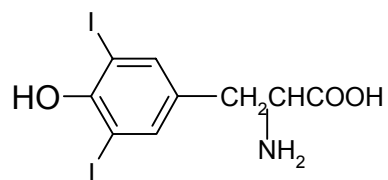

Iodotyrosine

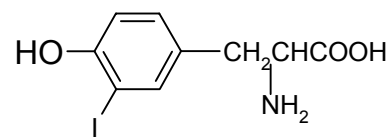

3. HEALTH EFFECTS

(Eng et al. 1999; Uyttersprot et al. 1997). Escape occurs when transport of iodide into the thyroid gland and the thyroid iodide concentration are sufficiently depressed to release the gland from inhibition of thyroid peroxidase, or other steps in the production of iodothyronines (Saller et al. 1998).

A variety of chemical inhibitors of iodine thyroid metabolism have been described (Figure 3-3, see Section 2.9).

The major pathways of metabolism of iodine that occur outside of the thyroid gland involve the catabolism of T_4 and T_3 , and include deiodination reactions, ether bond cleavage of thyronine, oxidative deamination and decarboxylation of the side chain of thyronine, and conjugation of the phenolic hydroxyl group on thyronine with glucuronic acid and sulfate (Figure 3-5). Deiodination products formed in peripheral tissues are depicted in Figure 3-6. The monodeiodination of T_4 to T_3 is the major source of production of peripheral T_3 , which has a greater hormonal potency than T_4 , and together with the production of 3,3',5-triiodo-L-thyronine (reverse T_3 , rT_3), account for approximately 80% of total T_4 turnover in humans (Engler and Burger 1984; Visser 1990). Deiodination of T_4 and T_3 also functions to deactivate the thyroid hormones. Iodide released from the deiodination reactions is either taken up by the thyroid gland or excreted in urine (see Section 3.3.4.2). Deiodination is catalyzed by selenium-dependent deiodinase enzymes (selenodiodinases) (see Section 3.5.1).

Oxidative deamination and decarboxylation of the alanine side chain of the iodothyronines represents approximately 2 and 14% of total of T_4 and T_3 turnover, respectively (Braverman et al. 1970; Gavin et al. 1980; Pittman et al. 1980; Visser 1990). Enzymes that catalyze these reactions have not been well characterized. Activity has been demonstrated in homogenates of rat kidney and brain, and the metabolites have been detected in a variety of tissues, including kidney, liver, and skeletal muscle (Engler and Burger 1984). The products of side chain deamination and decarboxylation, the acetic acid analogues of the iodothyronines, undergo deiodination and conjugation with glucuronic acid and sulfate (Engler and Burger 1984; Green and Ingbar 1961; Pittman et al. 1972).

Sulfate conjugation of the phenolic group of iodothyronines occurs in the liver and probably in other tissues. In humans, the reaction in liver is catalyzed by phenolic arylsulfotransferase (Young 1990). Iodothyronines having one iodine moiety on the phenolic ring are preferentially sulfated (Sekura et al. 1981; Visser 1994). The sulfated products undergo deiodination. Although a minor metabolite of the thyroid hormones under normal conditions, the sulfation pathway becomes more important when Type I deiodinase is inhibited; for example, by treatment with propylthiourea (Visser 1994).

Figure 3-5. Pathways of Metabolism of Iodothyronines

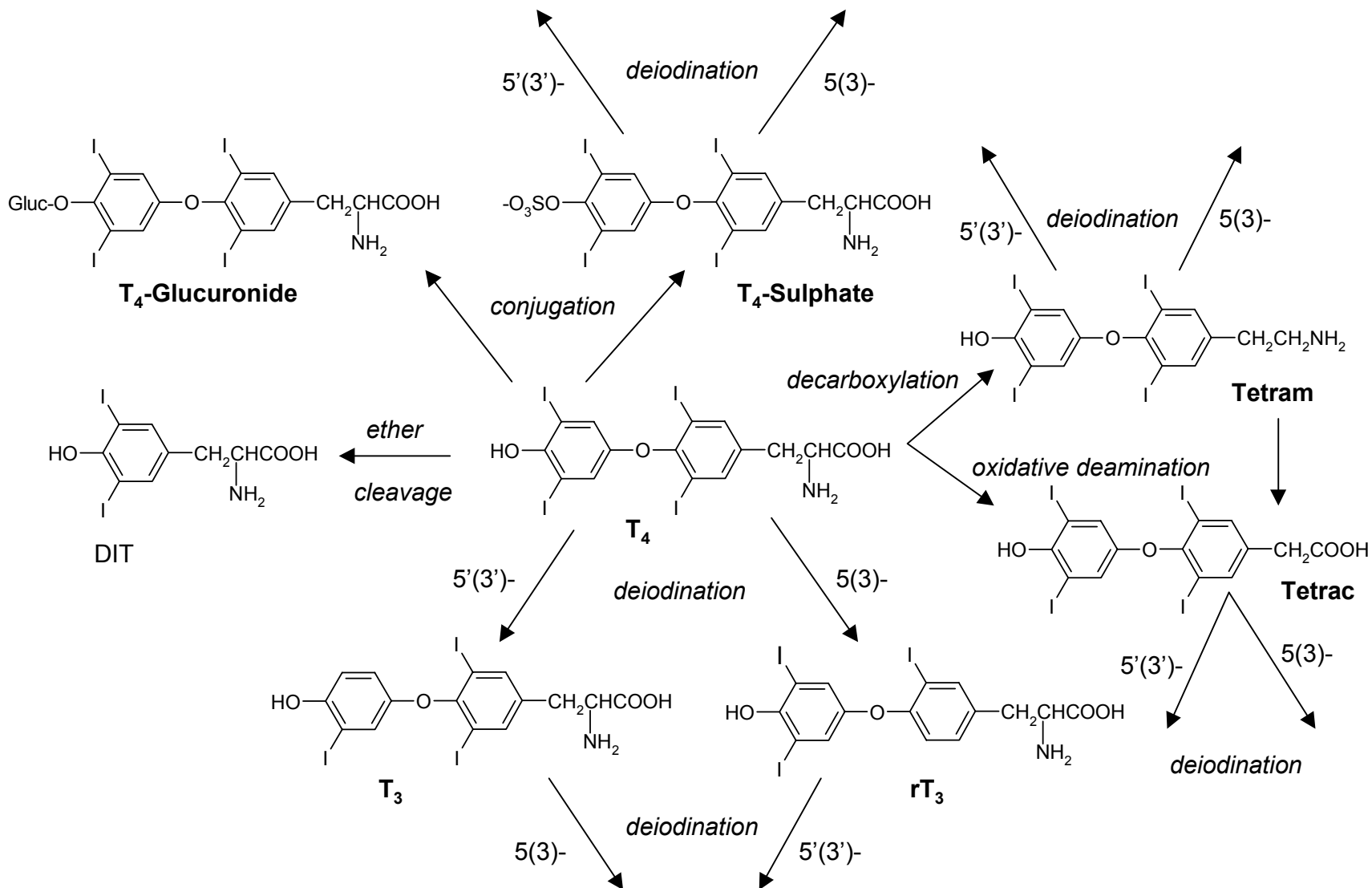

Source: Kohrle et al. 1987

Figure 3-6. Major Deiodination Pathways of Thyroid Hormones in Peripheral Tissues

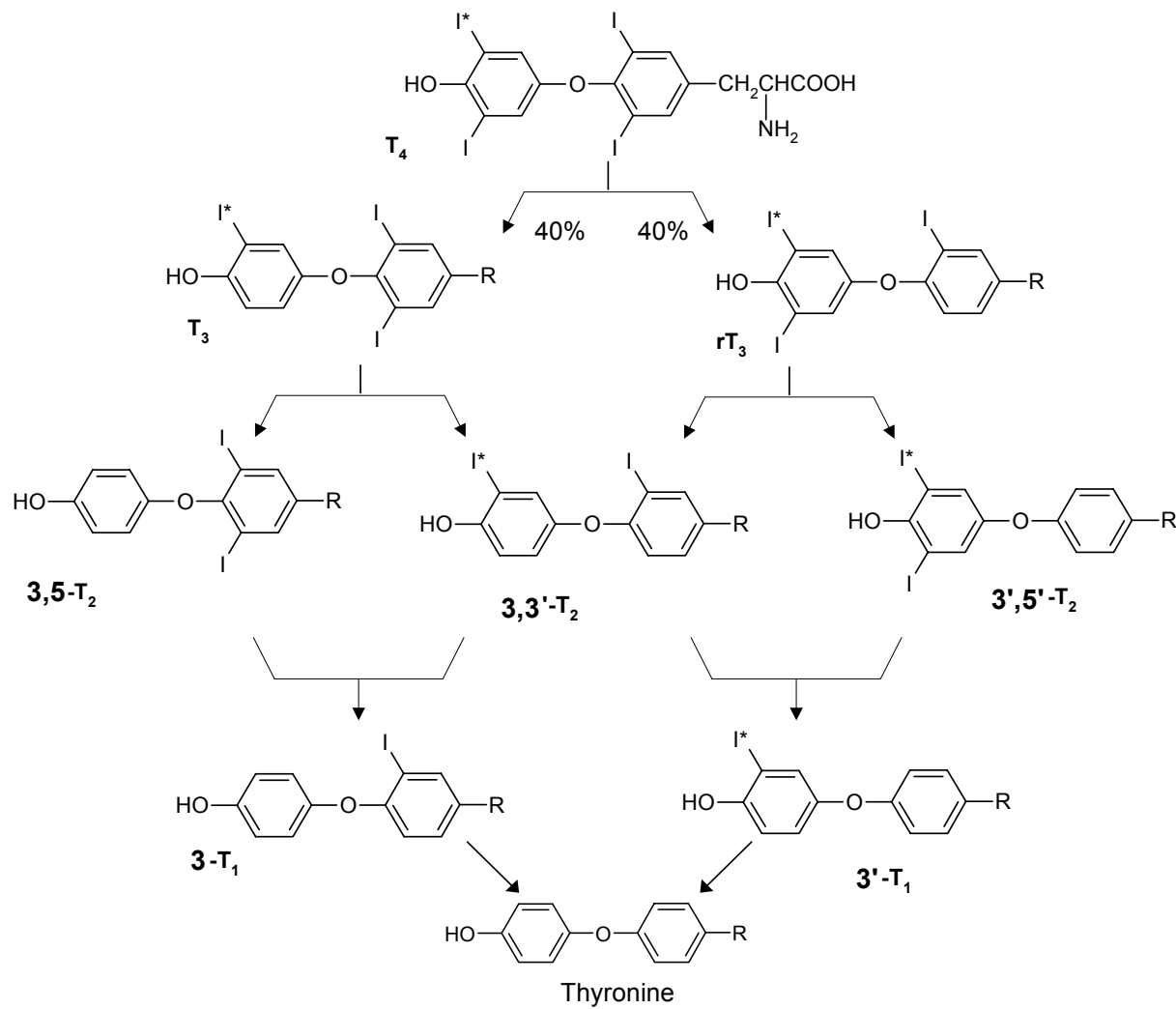

Source: Engler and

Burger 1984

3. HEALTH EFFECTS

Glucuronide conjugation of the phenolic hydroxyl group of the iodothyronines occurs in the liver and probably other tissues. The identity of the glucuronyltransferase enzymes that participate in the conjugation of iodothyronines has not been determined in humans; however, in rats, the activity has been shown to occur for the microsomal bilirubin, *p*-nitrophenol, and androsterone uridine diphosphate (UDP)-glucuronyltransferases (Visser et al. 1993). The activity of the pathway is increased by a variety of chemicals that induce microsomal enzymes, including benzopyrene, phenobarbital, 3-methylcholanthrene, polychlorinated biphenyls (PCBs), and 2,3,7,8-tetrachlorodibenzo-*p*-dioxin (TCDD) (Visser 1990).

Ether bond cleavage is a minor pathway of metabolism of iodotyrosines under normal conditions; however, it explains the observation of diiodotyrosine in serum of some patients who received high dosages of T₄ or who had severe bacterial infections (Meinhold et al. 1981, 1987, 1991). The reaction has been observed in phagocytosing leukocytes, which would be abundant during bacterial infections (Klebanoff and Green 1973).

3.4.3.3 Dermal Exposure

The metabolism of absorbed iodine is expected to be similar regardless of the route of exposure to inorganic iodine. A complete discussion of the metabolism of iodine after oral exposures to inorganic iodine is presented in Section 3.4.3.2, and is applicable to dermal exposures.

3.4.4 Elimination and Excretion

3.4.4.1 Inhalation Exposure

The excretion of absorbed iodine is expected to be similar regardless of the route of exposure to inorganic iodine. This is supported by studies in which humans were exposed to tracer levels of radioiodine as either I₂ or methyl iodide, and in studies in which monkeys inhaled particulate aerosols of sodium iodide (Black and Hounam 1968; Morgan et al. 1967a, 1967b, 1968; Perrault et al. 1967; Thieblemont et al. 1965). A complete discussion of the metabolism of iodine after oral exposures to inorganic iodine is presented in Section 3.4.3.2, and is applicable to dermal exposures.

3.4.4.2 Oral Exposure

Absorbed iodine is excreted primarily in the urine and feces, but is also excreted in breast milk, exhaled air, sweat, and tears (Cavalieri 1997). Urinary excretion normally accounts for >97% of the elimination of absorbed iodine, while fecal excretion accounts for approximately 1–2% (Larsen et al. 1998). Vadstrup

3. HEALTH EFFECTS

(1993) summarized data on the renal plasma clearance of iodide in humans and concluded that urinary excretion was approximately 20–30% of the glomerular filtration rate (see Section 3.5.1).

The glucuronide and sulfate conjugates of T_4 , T_3 , and metabolites are secreted into bile. Estimates of the magnitude of the biliary pathway have been obtained from analyses of bile samples collected from patients who underwent surgical cholecystectomy; the total secretion of T_4 and metabolites was approximately 10–15% of the daily metabolic clearance of T_4 (Langer et al. 1988; Myant 1956). More extensive quantitative information is available on the biliary secretion of iodothyronines conjugates in experimental animals. In rats, approximately 30% of T_4 clearance is accounted for by the biliary secretion of the glucuronide conjugate and 5% as the sulfate conjugate; once secreted, the conjugates undergo extensive hydrolysis with reabsorption of the iodothyronine in the small intestine (Visser 1990).

Iodide is excreted in human breast milk (Dydek and Blue 1988; Hedrick et al. 1986; Lawes 1992; Morita et al. 1998; Robinson et al. 1994; Rubow et al. 1994; Spencer et al. 1986). The fraction of the absorbed iodide dose excreted in breast milk varies with functional status of the thyroid gland. A larger fraction of the absorbed dose is excreted in breast milk in the hypothyroid state compared to the hyperthyroid state. In the hypothyroid state, uptake of absorbed iodide into the thyroid and incorporation into iodothyronines is depressed, resulting in greater availability of the absorbed iodide for distribution to the mammary gland and breast milk. Several examples of this have been reported in the clinical case literature. A woman who was hyperthyroid and received an oral tracer dose of radioiodine as [^{123}I]NaI during lactation excreted approximately 2.5% of the dose in breast milk collected over a 5.5-day period (Morita et al. 1998). The peak excretion (48.5% of the dose) occurred in the first postdosing collection of breast milk, which occurred 7 hours after the dose. A similar result, approximately 2.6% of the oral dose excreted in breast milk, was reported by Hedrick et al. (1986) for a hyperthyroid patient. By contrast, a hypothyroid patient excreted 25% of an oral dose of radioiodine (as [^{123}I]NaI) in breast milk in 41 hours (Robinson et al. 1994).

Iodide is excreted in human tears. In an adult patient (hypothyroid with thyroid hormone supplementation) who received an oral tracer dose of ^{123}I radioiodine, approximately 0.01% of the dose was recovered in tears collected over a 4-hour period. The peak activity in tears was observed 1 hour after the dose and activity was present in tears 24 hours after the dose (Bakheet et al. 1998).

Iodide is excreted into saliva in humans; however, the quantitative contribution of this pathway to excretion has not been reported, and is probably minimal, given the relatively small rate of production of saliva under normal circumstances, most of which is ingested (Brown-Grant 1961; Wolff 1983).

Iodide appears to be excreted into the intestine by a mechanism other than biliary secretion of iodothyronine (and metabolic conjugates). Evidence in support of this comes from observations of

3. HEALTH EFFECTS

radioactivity in the colon of patients who have no functioning iodothyronine production and who received doses of radioiodine. Kinetic analyses of the fecal excretion of radioiodine in euthyroid subjects also supports a direct blood-to-intestine excretion route for iodide (Hays 1993). Further support for a possible colonic excretory pathway in humans comes from experimental studies in cats and rats (Hays et al. 1992; Pastan 1957).

3.4.4.3 Dermal Exposure

The excretion of absorbed iodine is expected to be similar regardless of the route of exposure to inorganic iodine. A complete discussion of the metabolism of iodine after oral exposures to inorganic iodine is presented in Section 3.4.3.2, and is applicable to dermal exposures.

3.4.4.4 Other Routes of Exposure

3.4.5 Physiologically Based Pharmacokinetic (PBPK)/Pharmacodynamic (PD) Models

Physiologically based pharmacokinetic (PBPK) models use mathematical descriptions of the uptake and disposition of chemical substances to quantitatively describe the relationships among critical biological processes (Krishnan et al. 1994). PBPK models are also called biologically based tissue dosimetry models. PBPK models are increasingly used in risk assessments, primarily to predict the concentration of potentially toxic moieties of a chemical that will be delivered to any given target tissue following various combinations of route, dose level, and test species (Clewell and Andersen 1985). Physiologically based pharmacodynamic (PBPD) models use mathematical descriptions of the dose-response function to quantitatively describe the relationship between target tissue dose and toxic end points.

PBPK/PD models refine our understanding of complex quantitative dose behaviors by helping to delineate and characterize the relationships between: (1) the external/exposure concentration and target tissue dose of the toxic moiety, and (2) the target tissue dose and observed responses (Andersen et al. 1987; Andersen and Krishnan 1994). These models are biologically and mechanistically based and can be used to extrapolate the pharmacokinetic behavior of chemical substances from high to low dose, from route to route, between species, and between subpopulations within a species. The biological basis of PBPK models results in more meaningful extrapolations than those generated with the more conventional use of uncertainty factors.

The PBPK model for a chemical substance is developed in four interconnected steps: (1) model representation, (2) model parametrization, (3) model simulation, and (4) model validation (Krishnan and Andersen 1994). In the early 1990s, validated PBPK models were developed for a number of

3. HEALTH EFFECTS

toxicologically important chemical substances, both volatile and nonvolatile (Krishnan and Andersen 1994; Leung 1993). PBPK models for a particular substance require estimates of the chemical substance-specific physicochemical parameters, and species-specific physiological and biological parameters. The numerical estimates of these model parameters are incorporated within a set of differential and algebraic equations that describe the pharmacokinetic processes. Solving these differential and algebraic equations provides the predictions of tissue dose. Computers then provide process simulations based on these solutions.

The structure and mathematical expressions used in PBPK models significantly simplify the true complexities of biological systems. If the uptake and disposition of the chemical substance(s) is adequately described, however, this simplification is desirable because data are often unavailable for many biological processes. A simplified scheme reduces the magnitude of cumulative uncertainty. The adequacy of the model is, therefore, of great importance, and model validation is essential to the use of PBPK models in risk assessment.

PBPK models improve the pharmacokinetic extrapolations used in risk assessments that identify the maximal (i.e., the safe) levels for human exposure to chemical substances (Andersen and Krishnan 1994). PBPK models provide a scientifically sound means to predict the target tissue dose of chemicals in humans who are exposed to environmental levels (for example, levels that might occur at hazardous waste sites) based on the results of studies where doses were higher or were administered in different species. Figure 3-7 shows a conceptualized representation of a PBPK model.

The ICRP (1994b, 1996) developed a Human Respiratory Tract Model for Radiological Protection, which contains respiratory tract deposition and clearance compartmental models for inhalation exposure that may be applied to gases and vapors of iodine compounds and particulate aerosols of iodine. The ICRP (1979, 1989) also developed a biokinetic model for human oral exposure that applies to iodine. Several other multicompartamental models of iodine pharmacokinetics have been described, two of which are also described below because of either their extensive history of use in clinical applications of radioiodine (Oddie et al. 1955) or their potential value in environmental risk assessment (Stather and Greenhalgh 1983). The EPA (1998) has adopted the ICRP (1989, 1994a, 1995) models for assessment of radiologic risks from iodine exposures. The National Council on Radiation Protection and Measurement (NCRP) has also developed a respiratory tract model for inhaled radionuclides (NCRP 1997). At this time, the NCRP recommends the use of the ICRP model for calculating exposures for radiation workers and the general public. Readers interested in this topic are referred to NCRP Report No. 125; Deposition, Retention and Dosimetry of Inhaled Radioactive Substances (NCRP 1997). In the appendix to the report, NCRP provides the animal testing clearance data and equations fitting the data that supported the development of the human model.

3. HEALTH EFFECTS

Figure 3-7. Conceptual Representation of a Physiologically Based Pharmacokinetic (PBPK) Model for a Hypothetical Chemical Substance

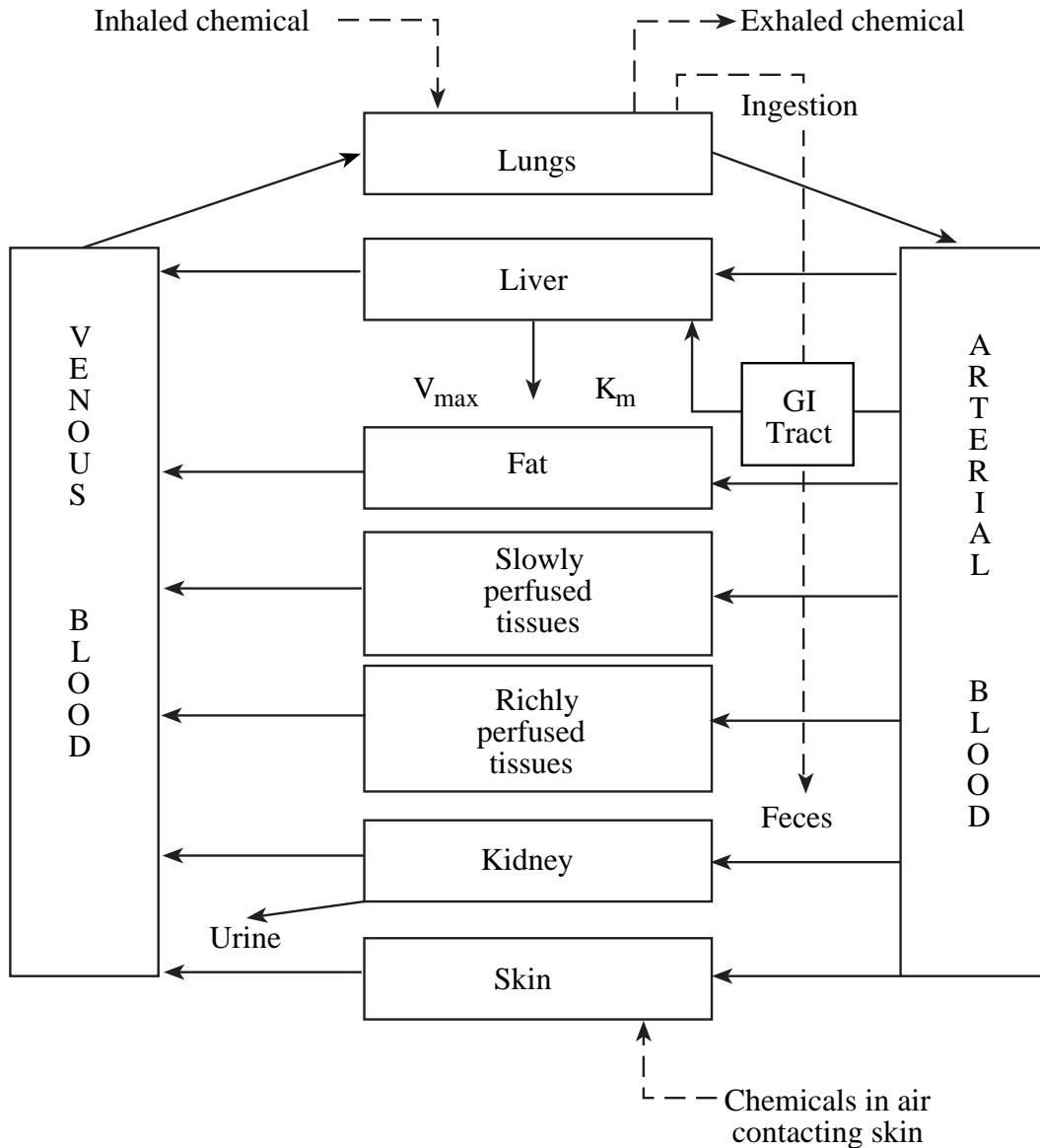

Source: adapted from Krishnan et al. 1994

Note: This is a conceptual representation of a physiologically based pharmacokinetic (PBPK) model for a hypothetical chemical substance. The chemical substance is shown to be absorbed via the skin, by inhalation, or by ingestion, metabolized in the liver, and excreted in the urine or by exhalation.

3. HEALTH EFFECTS

Human Respiratory Tract Model for Radiological Protection (ICRP 1994).

Deposition. The ICRP (1994) has developed a deposition model for behavior of aerosols and vapors in the respiratory tract. It was developed to estimate the fractions of radioactivity in breathing air that are deposited in each anatomical region of the respiratory tract. ICRP (1994b) provides inhalation dose coefficients that can be used to estimate the committed equivalent and effective doses to organs and tissues throughout the body based on a unit intake of radioactive material. The model applies to three levels of particle solubility, and a wide range of particle sizes (approximately 0.0005–100 μm in diameter) and parameter values, and can be adjusted for various segments of the population (e.g., sex, age, level of physical exertion). This model also allows the evaluation of the bounds of uncertainty in deposition estimates. Uncertainties arise from natural biological variability among individuals and the need to interpret some experimental evidence that remains inconclusive. It is applicable to gases and vapors of volatile iodine compounds (e.g., I_2 and methyl iodide) and particulate aerosols containing iodine, but was developed for a wide variety of radionuclides and their chemical forms.

The ICRP deposition model estimates the amount of inhaled material that initially enters each compartment (see Figure 3-8). The model was developed with 5 compartments: (1) the anterior nasal passages (ET_1); (2) all other extrathoracic airways (ET_2) (posterior nasal passages, the naso- and oropharynx, and the larynx); (3) the bronchi (BB); (4) the bronchioles (bb); and (5) the alveolar interstitium (AI). Particles deposited in each of the regions may be removed from each region and redistributed either upward into the respiratory tree or to the lymphatic system and blood by different particle removal mechanisms.

For extrathoracic deposition of particles, the model uses experimental data (where deposition is related to particle size and airflow parameters) and scales deposition for women and children from adult male data. Similar to the extrathoracic region, experimental data served as the basis for lung (bronchi, bronchioles, and alveoli) aerosol transport and deposition. A theoretical model of gas transport and particle deposition was used to interpret data and to predict deposition for compartments and subpopulations other than adult males. Table 3-5 provides reference respiratory values for the general Caucasian population under several levels of activity.

Deposition of inhaled gases and vapors is modeled as a partitioning process that depends on the physiological parameters noted above as well as the solubility and reactivity of compound in the respiratory tract (Figure 3-9). The ICRP (1994b) model defines three categories of solubility and reactivity: SR-0, SR-1, and SR-2:

3. HEALTH EFFECTS

**Figure 3-8. Respiratory Tract Compartments*
in Which Particles May be Deposited**

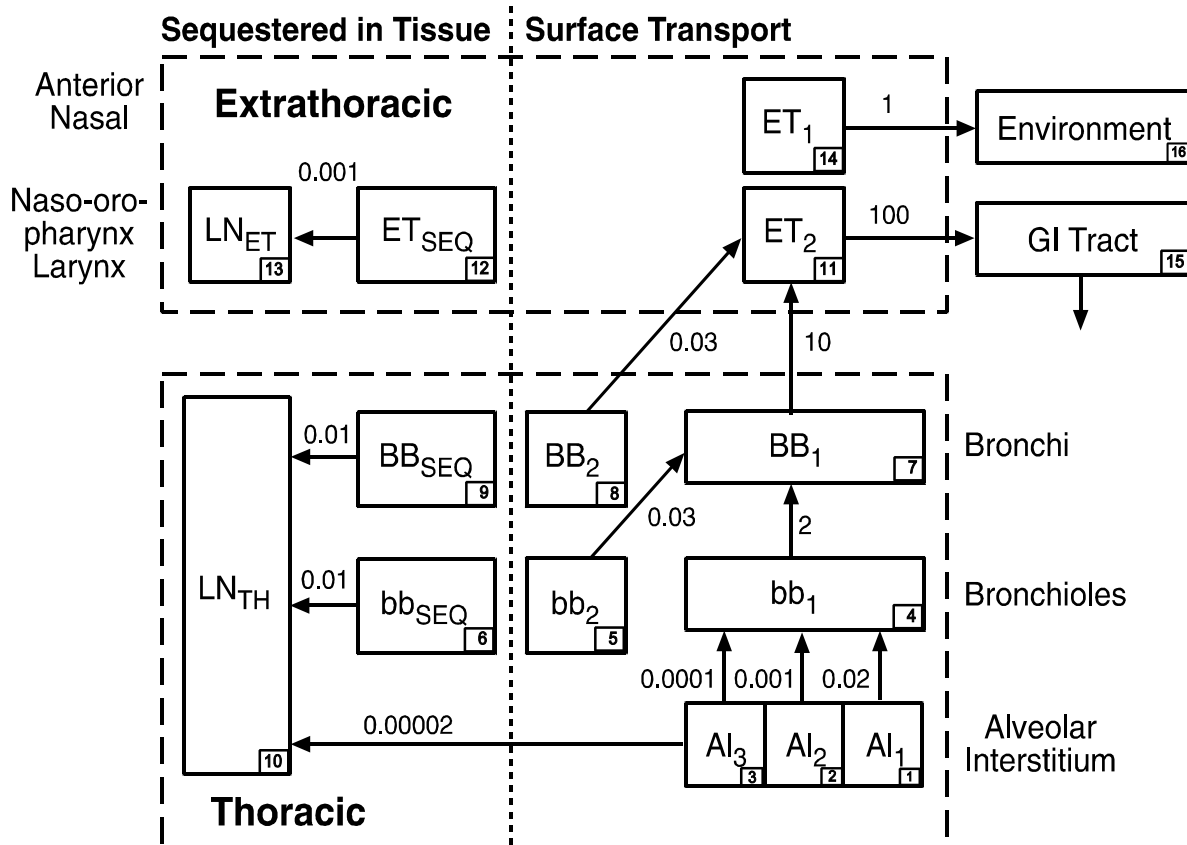

*Compartment numbers shown in lower right corners are used to define clearance pathways. The clearance pathways as well as the compartment abbreviations are presented in Table 3-6.

Source: ICRP 1994b

Table 3-5. Reference Respiratory Values for a General Caucasian Population at Different Levels of Activity

Activity:	Resting (sleeping)			Sitting awake			Light exercise			Heavy exercise				
Maximal workload (%):	8			12			32			64				
Breathing parameters: ^b	V_T (L)	B (m ³ h ⁻¹)	f_R (min ⁻¹)	V_T (L)	B (m ³ h ⁻¹)	f_R (min ⁻¹)	V_T (L)	B (m ³ h ⁻¹)	f_R (min ⁻¹)	V_T (L)	B (m ³ h ⁻¹)	f_R (min ⁻¹)		
Age	Sex													
3 months	0.04	0.09	38	N/A	N/A	N/A	0.07	0.19	48	N/A	N/A	N/A		
1 year	0.07	0.15	34	0.1	0.22	36	0.13	0.35	46	N/A	N/A	N/A		
5 years	0.17	0.24	23	0.21	0.32	25	0.24	0.57	39	N/A	N/A	N/A		
10 years	Male:									0.841	2.22	44		
	Both:		0.3	0.31	17	0.33	0.38	19	0.58	1.12	32			
	Female:									0.667	1.84	46		
15 years	Male:		0.500	0.42	14	0.533	0.48	15	1.0	1.38	23	1.352	2.92	36
	Female:		0.417	0.35	14	0.417	0.40	16	0.903	1.30	24	1.127	2.57	38
Adult	Male:		0.625	0.45	12	0.750	0.54	12	1.25	1.5	20	1.923	3.0	26
	Female:		0.444	0.32	12	0.464	0.39	14	0.992	1.25	21	1.364	2.7	33

^aSee Annexe B (ICRP 1994b) for data from which these reference values were derived

^b V_T = Tidal volume, B = ventilation rate, f_R = respiration frequency.

h = hour; L = liter; m = meter; min = minute; N/A = not applicable

Figure 3-9. Reaction of Gases or Vapors at Various Levels of the Gas-Blood Interface

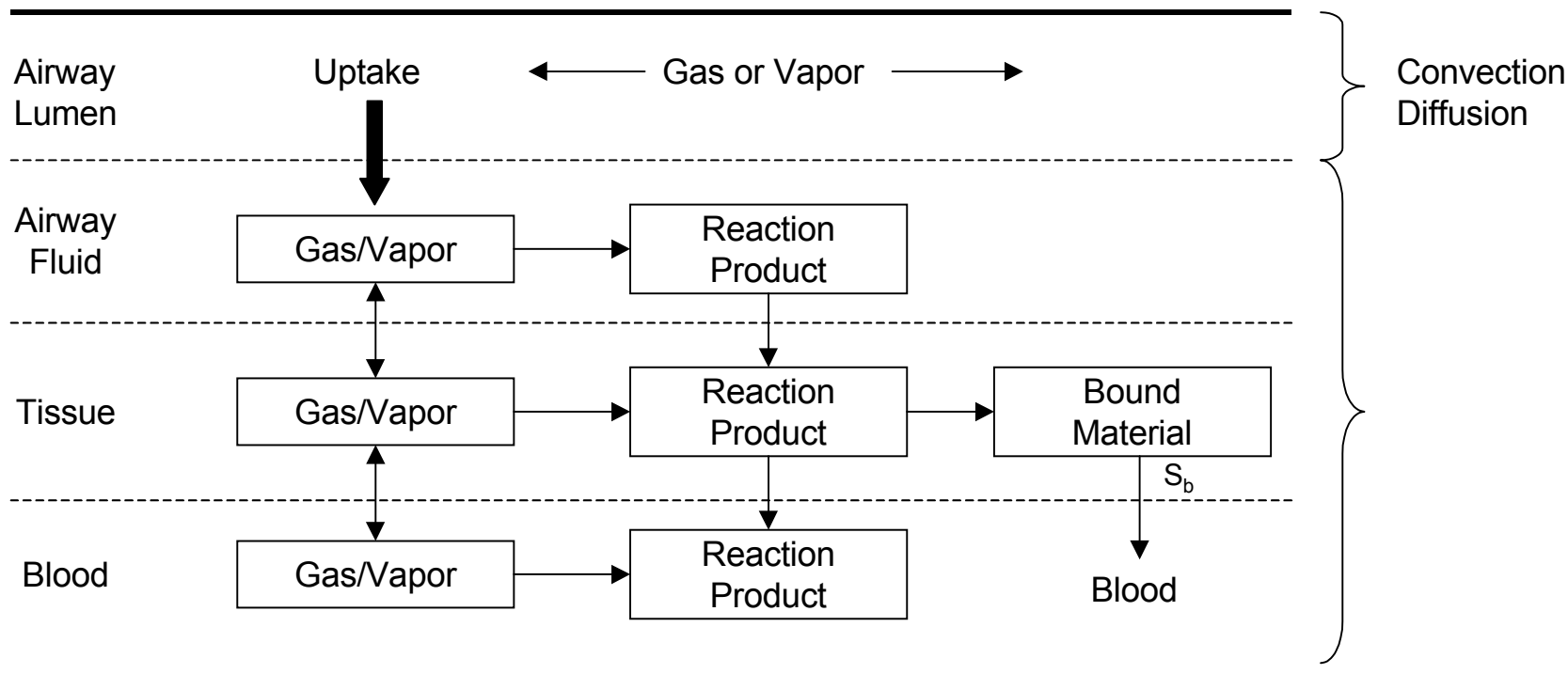

DRAFT FOR PUBLIC COMMENT

Source: ICRP 1994b

3. HEALTH EFFECTS

- Type SR-0 compounds include insoluble and nonreactive gases (e.g., inert gases such as H₂, He). These compounds do not significantly interact with the respiratory tract tissues and essentially all compound inhaled is exhaled. Radiation doses from inhalation of SR-0 compounds are assumed to result from the irradiation of the respiratory tract from the air spaces.
- Type SR-1 compounds include soluble or reactive gases and vapors that are expected to be taken up by the respiratory tract tissues and may deposit in any or all of the regions of the respiratory tract, depending on the dynamics of the airways and properties of the surface mucous and airway tissues, as well as the solubility and reactivity of the compound. Molecular iodine (I₂) and methyl iodide are classified as SR-1 compounds (ICRP 1995). Deposition of molecular iodine vapor is assumed to occur in ET₁ (10%), ET₂ (40%), and BB (50%) regions of the respiratory tract, whereas 70% of inhaled methyl iodide is assumed to deposit uniformly in ET₂ and deeper regions of the respiratory tract (ICRP 1995).
- Type SR-2 compounds include soluble and reactive gases and vapors that are completely retained in the extrathoracic regions of the respiratory tract. SR-2 compounds include sulfur dioxide (SO₂) and hydrogen fluoride (HF).

Respiratory Tract Clearance. This portion of the model identifies the principal clearance pathways within the respiratory tract. The model was developed to predict the retention of various radioactive materials. Figure 3-10 presents the compartmental model and is linked to the deposition model (see Figure 3-8) and to reference values presented in Table 3-6. Table 3-6 provides clearance rates and deposition fractions for each compartment for insoluble particles. The table provides rates of insoluble particle transport for each of the compartments, expressed as a fraction per day and also as half-time. ICRP (1994b) also developed modifying factors for some of the parameters, such as age, smoking, and disease status. Parameters of the clearance model are based on human evidence for the most part, although particle retention in airway walls is based on experimental data from animal experiments.

The clearance of particles from the respiratory tract is a dynamic process. The rate of clearance generally changes with time from each region and by each route. Following deposition of large numbers of particles (acute exposure), transport rates change as particles are cleared from the various regions. Physical and chemical properties of deposited material determine the rate of dissolution, and as particles dissolve, absorption rates tend to change over time. By creating a model with compartments of different clearance rates within each region (e.g., BB₁, BB₂, BB_{seq}), the ICRP model overcomes problems associated with time-dependent functions. Each compartment clears to other compartments by constant rates for each pathway.

3. HEALTH EFFECTS

Table 3-6. Reference Values of Parameters for the Compartment Model to Represent Time-dependent Particle Transport from the Human Respiratory Tract

Part A

Clearance Rates for Insoluble Particles

Pathway	From	To	Rate (d ⁻¹)	Half-time ^a
m _{1,4}	Al ₁	bb ₁	0.02	35 days
m _{2,4}	Al ₂	bb ₁	0.001	700 days
m _{3,4}	Al ₃	bb ₁	0.0001	7,000 days
m _{3,10}	Al ₃	LN _{TH}	0.00002	—
m _{4,7}	bb ₁	BB ₁	2	8 hours
m _{5,7}	bb ₂	BB ₁	0.03	23 days
m _{6,10}	bb _{seq}	LN _{TH}	0.01	70 days
m _{7,11}	BB ₁	ET ₂	10	100 minutes
m _{8,11}	BB ₂	ET ₂	0.03	23 days
m _{9,10}	BB _{seq}	LN _{TH}	0.01	70 days
m _{11,15}	ET ₂	GI tract	100	10 minutes
m _{12,13}	ET _{seq}	LN _{ET}	0.001	700 days
m _{14,16}	ET ₁	Environment	1	17 hours

See next page for Part B

3. HEALTH EFFECTS

Table 3-6. Reference Values of Parameters for the Compartment Model to Represent Time-dependent Particle Transport from the Human Respiratory Tract (*continued*)

Part B

Partition of deposit in each region between compartments^b

Region or deposition site	Compartment	Fraction of deposit in region assigned to compartment ^c
ET ₂	ET ₂	0.9995
	ET _{seq}	0.0005
BB	BB ₁	0.993- <i>f_s</i>
	BB ₂	<i>f_s</i>
	BB _{seq}	0.007
bb	bb ₁	0.993- <i>f_s</i>
	bb ₂	<i>f_s</i>
	bb _{seq}	0.007
Al	Al ₁	0.3
	Al ₂	0.6
	Al ₃	0.1

^aThe half-times are approximate since the reference values are specified for the particle transport rates and are rounded in units of d⁻¹. A half-time is not given for the transport rate from Al₃ to LN_{TH}, since this rate was chosen to direct the required amount of material to the lymph nodes. The clearance half-time of compartment Al₃ is determined by the sum of the clearance rates from it.

^bSee paragraph 181, Chapter 5 (ICRP 1994) for default values used for relating *f_s* to *d_{ae}*.

^cIt is assumed that *f_s* is size-dependent. For modeling purposes, *f_s* is taken to be:

$$f_s = 0.5 \text{ for } d_{ae} \leq 2.5\sqrt{\rho/\chi} \text{ } \mu\text{m and}$$

$$f_s = 0.5e^{0.63(d_{ae}\sqrt{\rho/\chi}-2.5)} \text{ for } d_{ae} > 2.5\sqrt{\rho/\chi} \text{ } \mu\text{m}$$

where

f_s = fraction subject to slow clearance
d_{ae} = aerodynamic particle diameter/(μm)
 ρ = particle density (g/cm^3)
 χ = particle shape factor

Al = alveolar-interstitial region; BB = bronchial region; bb = bronchiolar region; BB_{seq} = compartment representing prolonged retention in airway walls of small fraction of particles deposited in the bronchial region; bb_{seq} = compartment representing prolonged retention in airway walls of small fraction of particles deposited in the bronchiolar region; d = day(s); ET = extrathoracic region; ET_{seq} = compartment representing prolonged retention in airway tissue of small fraction of particles deposited in the nasal passages; LN_{ET} = lymphatics and lymph nodes that drain the extrathoracic region; LN_{TH} = lymphatics and lymph nodes that drain the thoracic region

Source: ICRP 1994b

3. HEALTH EFFECTS

Figure 3-10. Compartment Model to Represent Time-Dependent Particle Transport in the Respiratory Tract

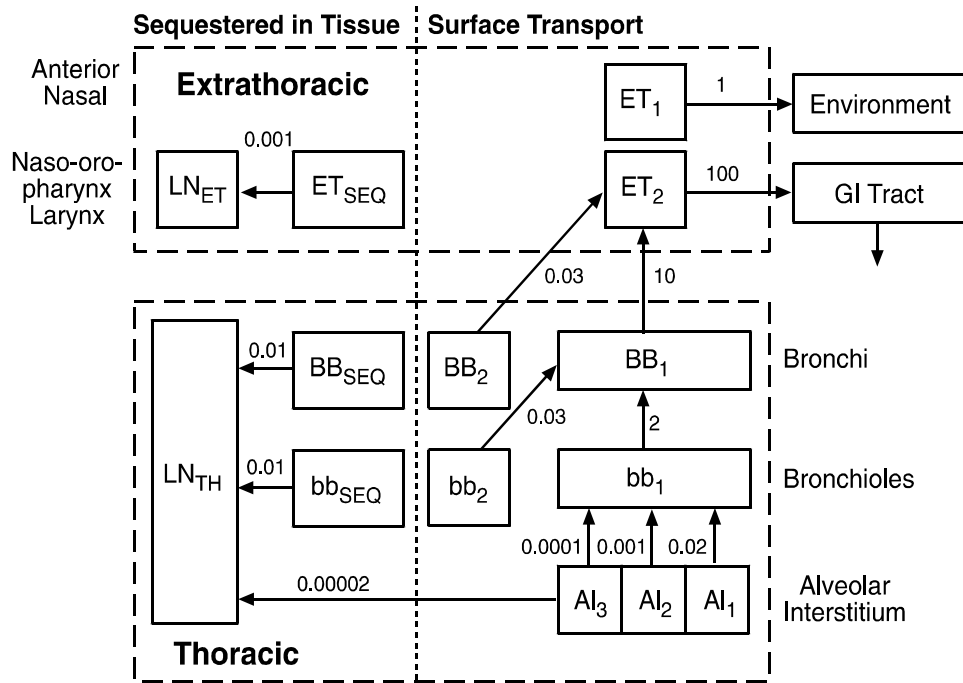

Source: ICRP 1994b

See Table 3-6 for abbreviations, rates, half-lives, and fractions by compartment

3. HEALTH EFFECTS

Particle transport from all regions is toward both the lymph nodes and the pharynx, and a majority of deposited particles end up being swallowed. In the front part of the nasal passages (ET₁), nose blowing, sneezing, and wiping remove most of the deposited particles. Particles remain here for about a day. For particles with AMADs a few micrometers or greater, the ET₁ compartment is probably the largest deposition site. A majority of particles deposited at the back of the nasal passages and in the larynx (ET₂) are removed quickly by the fluids that cover the airways. In this region, particle clearance is completed within 15 minutes.

Ciliary action removes deposited particles from both the bronchi and bronchioles. Though it is generally thought that mucociliary action rapidly transports most particles deposited here toward the pharynx, a fraction of these particles are cleared more slowly. Evidence for this is found in human studies. For humans, retention of particles deposited in the lungs (BB and bb) is apparently biphasic. The “slow” action of the cilia may remove as many as half of the bronchi- and bronchiole-deposited particles. In human bronchi and bronchiole regions, mucus moves more slowly the closer to the alveoli it is. For the faster compartment, it has been estimated that it takes about 2 days for particles to travel from the bronchioles to the bronchi and 10 days from the bronchi to the pharynx. The second (slower) compartment is assumed to have approximately equal fractions deposited between BB₂ and bb₂, both with clearance half-times estimated at 20 days. Particle size is a primary determinant of the fraction deposited in this slow thoracic compartment. A small fraction of particles deposited in the BB and bb regions is retained in the airway wall for even longer periods (BB_{seq} and bb_{seq}).

If particles reach and become deposited in the alveoli, they tend to stay imbedded in the fluid on the alveolar surface or move into the lymph nodes. The one mechanism by which particles are physically resuspended and removed from the AI region is coughing. For modeling purposes, the AI region is divided into three subcompartments to represent different clearance rates, all of which are slow.

In the alveolar-interstitial region, human lung clearance has been measured. The ICRP model uses two half-times to represent clearance: about 30% of the particles have a 30-day half-time, and the remaining 70% are given a half-time of several hundred days. Over time, AI particle transport falls and some compounds have been found in lungs 10–50 years after exposure.

Absorption into Blood. The ICRP model assumes that absorption into blood occurs at equivalent rates in all parts of the respiratory tract, except in the anterior nasal passages (ET₁), where no absorption occurs. It is essentially a 2-stage process, as shown in Figure 3-11. First, there is a dissociation (dissolution) of particles; then the dissolved molecules or ions diffuse across capillary walls and are taken up by the blood. Immediately following dissolution, rapid absorption is observed. For some elements, rapid absorption does not occur because of binding to respiratory-tract components. In the absence of specific data for

3. HEALTH EFFECTS

Figure 3-11. The Human Respiratory Tract Model: Absorption into Blood

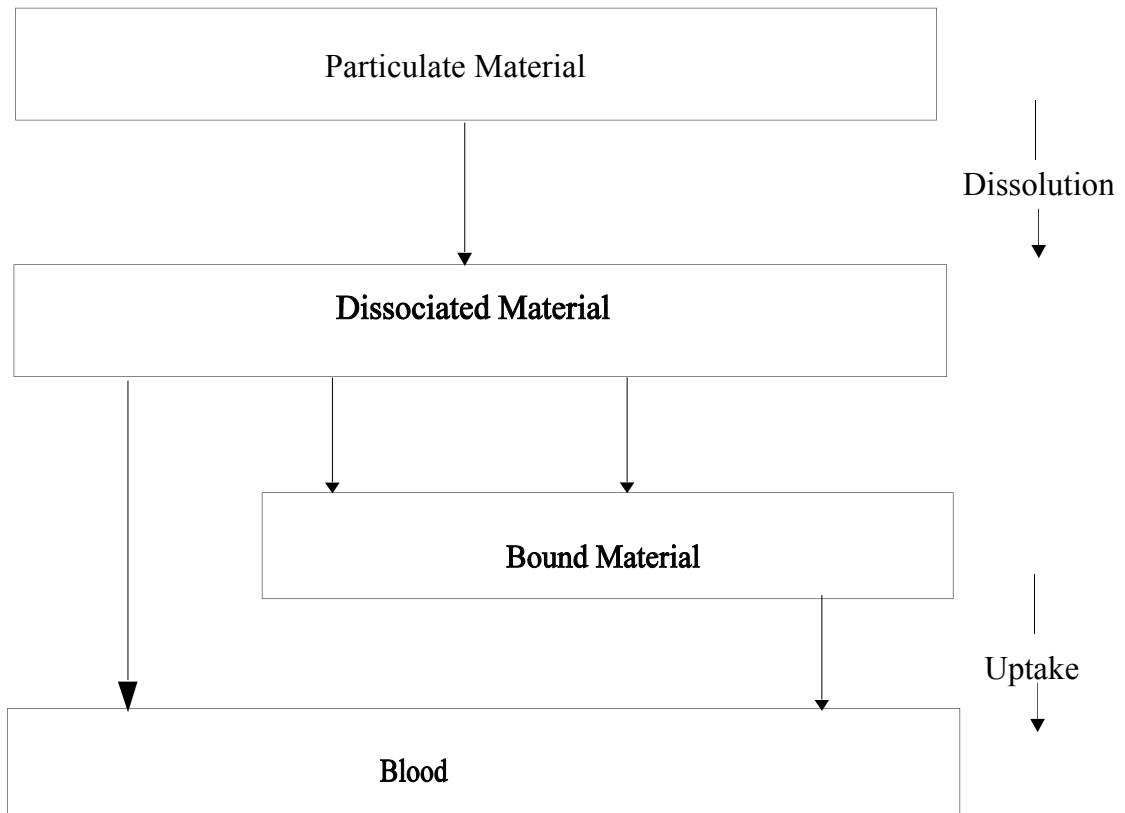

Source: ICRP 1994b

3. HEALTH EFFECTS

specific compounds, the model uses the following default absorption rate values for those specific compounds that are classified as Types F (fast), M (medium), S (slow), and V (instantaneous):

- C For Type F, there is rapid 100% absorption within 10 minutes of the material deposited in the BB, bb, and AI regions, and 50% of material deposited in ET₂. Thus, for nose breathing, there is rapid absorption of approximately 25% of the deposit in ET and 50% for mouth breathing. Type F iodine compounds include molecular iodine (I₂) and particulate aerosols of silver iodide and sodium iodide.
- C For Type M, about 70% of the deposit in AI reaches the blood eventually. There is rapid absorption of about 10% of the deposit in BB and bb, and 5% of material deposited in ET₂. Thus, there is rapid absorption of approximately 2.5% of the deposit in ET for nose breathing, and 5% for mouth breathing. ICRP (1995) does not identify any Type M iodine compounds.
- C For Type S, 0.1% is absorbed within 10 minutes and 99.9% is absorbed within 7,000 days, so there is little absorption from ET, BB, or bb, and about 10% of the deposit in AI reaches the blood eventually. ICRP (1995) does not identify any Type S iodine compounds.
- C For Type V, complete absorption (100%) is considered to occur instantaneously. Methyl iodide is classified as a Type V compound (ICRP 1995).

ICRP (1989) Iodine Biokinetics Model**Description of the model.**

ICRP (1989) developed a compartmental model of the kinetics of ingested iodine in humans with versions that are applicable to infants, children, adolescents, and adults. The model is a modification and expansion of a similar model described in ICRP (1979). Ingested iodine is assumed to be completely absorbed. Absorbed iodine is assumed to distribute to three compartments: blood, thyroid gland, and extrathyroid tissues (Figure 3-12). Of the iodine entering the transfer compartment, 30% is assumed to be transferred to the thyroid gland; the remaining 70% is excreted in urine. All iodine eliminated from the thyroid gland is assumed to be transferred to the extrathyroidal tissues compartment as organic iodine (e.g., iodothyronines). Twenty percent of the of iodine eliminated from extrathyroidal tissues is assumed to be excreted in feces; the remaining 80% is transferred to blood. Elimination half-times of iodine from blood, thyroid and extrathyroidal tissues are age-dependent (Figure 3-12). The modifications made in this model from ICRP (1979) include: (1) 20%, rather than 10% of the of iodine eliminated from extrathyroidal tissues is assumed to be excreted in feces; (2) age-dependent elimination half-times for iodine, which allows the model to be applied to infants, children, adolescents, and adults; and (3) the extrathyroidal iodine pool is assumed to be 0.1 of the thyroid pool and the thyroid iodine pool is allowed to be variable, reflecting geographic variation or other sources of variation in intake.

3. HEALTH EFFECTS

Figure 3-12. ICRP (1989) Metabolic Model for Iodine

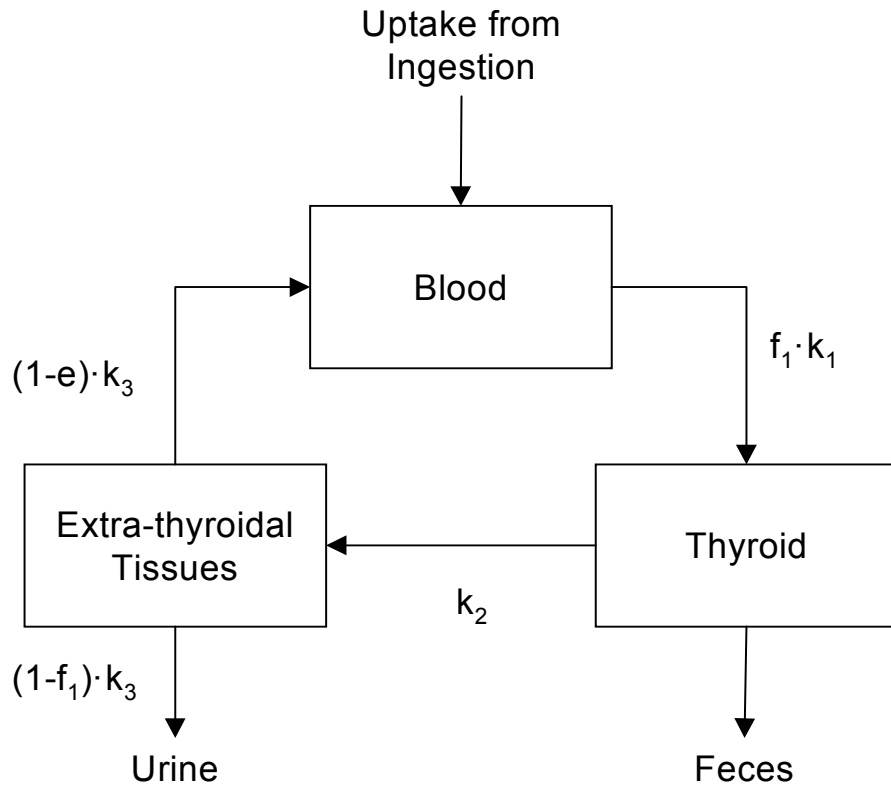

ICRP (1989) Metabolic Model for Iodine

Age	f_1	Thyroid uptake (%)	Fecal excretion (%)	Biological half-time ^a (d)			Apparent half-time ^b (d)
				Blood T_1	Thyroid T_2	Extrathyroidal T_3	
3 months	1	30	20	0.25	11.2	1.12	15
1 year	1	30	20	0.25	15	1.5	20
5 years	1	30	20	0.25	23	2.3	30
10 years	1	30	20	0.25	58	5.8	70
15 years	1	30	20	0.25	67	6.7	80
Adult	1	30	20	0.25	80	12	91

^a $\ln 2/k_i$
^b2–16 days after uptake

3. HEALTH EFFECTS

Validation of the model.

The extent to which the ICRP model has been validated is not described in ICRP (1989).

Risk assessment.

The model has been used to establish radiation dose equivalents (Sv/Bq) of ingested radioiodine (^{129}I , ^{131}I , and ^{132}I) for ages 3 months to 70 years (ICRP 1989).

Target tissues.

The model is designed to calculate radioiodine intake limits based on radiation dose to all major organs, including the thyroid gland.

Species extrapolation.

The model is designed for applications to human dosimetry and cannot be applied to other species without modification.

Interroute extrapolation.

The model is designed to simulate oral exposures to radioiodine and cannot be applied to other routes of exposure without modification.

NRPB-UK Model.**Description of the model.**

The National Radiological Protection Board of the United Kingdom (NRPB-UK) developed a compartmental model of ingested iodine in human adults and children (Stather and Greenhalgh 1983). The model has three compartments representing the thyroid gland, an inorganic iodide pool that includes all inorganic iodide in the body with the exception of that in the thyroid gland, and an organic iodine pool, exclusive of organic iodine in the thyroid gland (Figure 3-13). Iodide that enters the gastrointestinal tract from ingestion is assumed to be completely absorbed into the inorganic iodide pool. Of the iodine entering the inorganic iodide pool, 25% is transferred to the thyroid gland where it resides with an elimination half-time of 79 days; the rest is excreted in urine. The thyroid gland is assumed to have a steady state iodine content of 8 mg. All iodine eliminated from the thyroid gland is assumed to be transferred to the organic iodine pool where it resides with an elimination half-time of 8 days. Twenty percent of the iodine

3. HEALTH EFFECTS

Figure 3-13. NRPB-UK (1989) Metabolic Model for Iodine

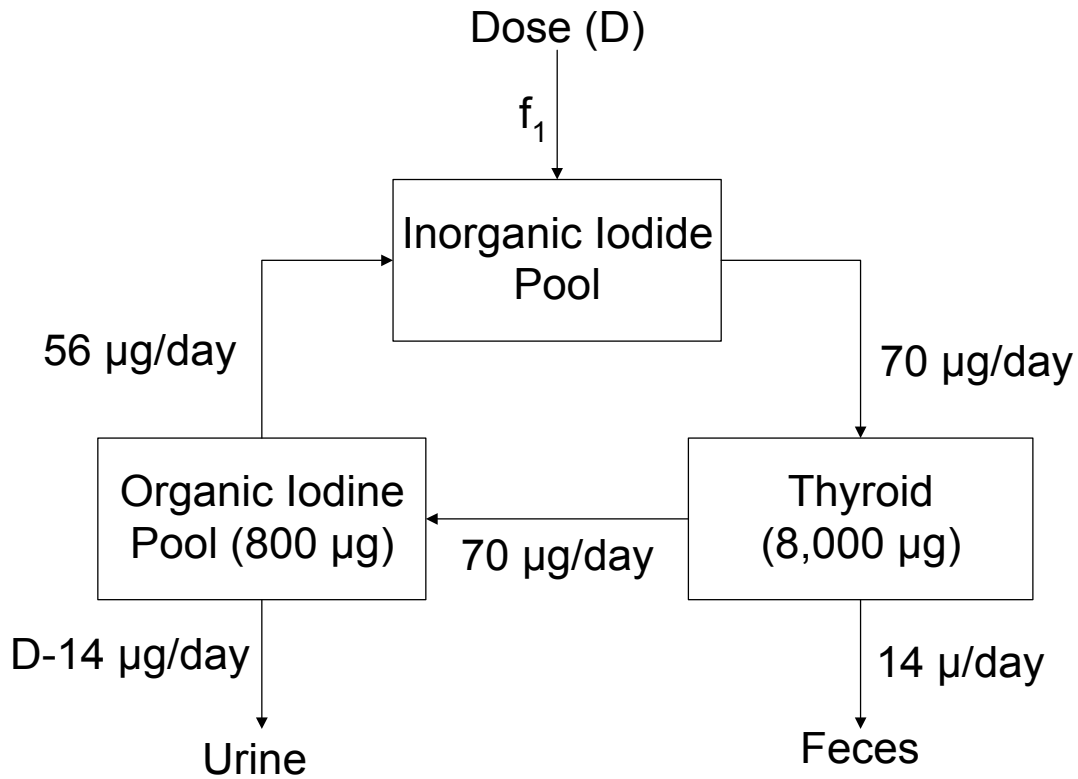

Source: Stather and Greenhalgh 1983

3. HEALTH EFFECTS

eliminated from the organic iodine pool is assumed to be excreted in feces; the remaining 80% enters the inorganic iodide pool.

Models for 1-year-old infants and 10-year-old children are also described in Stather and Greenhalgh (1983). The models are essentially the same as the adult model with one change; the elimination half-time for iodine in the thyroid gland is assumed to be 17 days for 1-year-old infants and 72 days for 10-year-old children.

Validation of the model.

The extent to which the NRPB-UK model has been validated is not described in Stather and Greenhalgh (1983).

Risk assessment.

The model was developed for calculating radiation doses to populations in the United Kingdom following release of iodine isotopes into the environment. The extent to which the model has been used for this purpose is not described in Stather and Greenhalgh (1983).

Target tissues.

The model is designed to calculate intake and exposure limits, based on radiation dose to the thyroid gland.

Species extrapolation.

The model is designed for applications to human dosimetry and cannot be applied to other species without modification.

Interoute extrapolation.

The model is designed to simulate oral exposures to radioiodine and cannot be applied to other routes of exposure without modification.

Oddie et al. Model.

3. HEALTH EFFECTS

Description of the model.

Oddie et al. (1955) described a compartmental model of absorbed iodine human adults and infants (Fisher et al. 1962) for predicting 24-hour radioiodine uptake by the thyroid gland in clinical procedures. The model has two compartments representing the thyroid gland and a central iodide pool that includes all inorganic iodide in the body with the exception of that in the thyroid gland. An organic iodine pool is not included in the model. Although this would preclude the model from accurately simulating radioiodide levels in extrathyroidal tissues, including blood, it was not considered necessary for simulating the initial uptake of iodide by the thyroid following a single dose of radioiodine, prior to significant release of organic iodine from the thyroid gland. Iodide that enters the inorganic iodide pool is assumed to be transferred either to the thyroid gland, represented as a first order rate constant k_1 , or to the kidney for urinary excretion, represented by a rate constant k_2 , usually corrected for loss of iodide in sweat, feces, and uncollected urine (Oddie and Fisher 1967). In a study of 20 healthy adults, k_1 was estimated to be 60×10^{-5} /minute in subjects who ingested a tracer dose of radioiodine (Fisher et al. 1965). In this same study, the value of k_1 was 49×10^{-5} after 13 weeks of daily ingestion of 252 μg iodide/day and 35×10^{-5} , after 13 weeks of daily ingestion of 1,000 μg iodide/day. The estimate of k_2 from this study was 300×10^{-5} minute^{-1} . Values for k_1 estimated in various populations have ranged from 67 to 134×10^{-5} minute^{-1} (Oddie and Fisher 1967). The volume of the iodide space was estimated to be 2.1 L (Fisher et al. 1965).

The same model has been used to predict thyroid uptakes of iodine in infants. Values for k_1 and k_2 were estimated from studies in which 24-hour thyroid uptakes of iodine were measured in 26 euthyroid newborn infants (Fisher et al. 1962). The values for k_1 and k_2 were 2.4×10^{-3} minute^{-1} and 1.1×10^{-3} minute^{-1} , respectively. The iodide space was estimated to be approximately 0.4 L in newborn infants.

Validation of the model.

The model has been shown to predict 24-hour iodine uptakes in the thyroid in adults who received single doses of radioiodine. Predicted 24-hour thyroid uptakes of radioiodine were compared to observed estimates in 1,573 euthyroid subjects reported from various studies; the difference between observed and predicted estimated for 8 studies ranged from 0.7 to 2.1%, with the observed uptakes ranging from 21 to 37% (Oddie and Fisher 1967).

Risk assessment.

The model was developed for predicting the 24-hour uptake of radioiodine in the thyroid after single doses of radioiodine are given in the clinical setting for assessing thyroid function. It has been evaluated in

3. HEALTH EFFECTS

terms of its predictive value in detecting abnormal thyroid conditions that affect iodide uptake into the gland (Oddie et al. 1960). The extent to which the model has been used for risk assessment could not be ascertained from the available literature.

Target tissues.

The model is designed to predict 24-hour uptakes of radioiodine into the thyroid gland.

Species extrapolation.

The model is designed for applications to humans and cannot be applied to other species without modification.

Interoute extrapolation.

The model is designed to simulate oral ingestion or parenteral injection (e.g., intramuscular in infants) of radioiodine and cannot be applied to other routes of exposure without modification.

3.5 MECHANISMS OF ACTION

3.5.1 Pharmacokinetic Mechanisms

Absorption. The mechanism(s) by which iodide is absorbed from the gastrointestinal tract is not known. Based on studies conducted by Small et al. (1961), absorption appears to occur primarily in the small intestine in humans. This study measured iodine in the saliva of healthy human subjects who ingested 0.25 g of potassium iodide (0.19 g iodide) together with a radioopaque suspension of barium sulfate that allowed the emptying of the stomach to be imaged with a fluoroscope. In five subjects, iodine was not detected in saliva until 2–3 minutes after the first appearance of the barium sulfate in the duodenum; the actual time of appearance relative to the oral dose of iodide ranged from 15 to 40 minutes. An intravenous dose of probanthine, which delays gastric emptying time, given just prior to the oral dose of potassium iodide, substantially delayed the time of appearance of iodine in saliva to 114–133 minutes; however, in each of three subjects, iodine was detected in saliva 3–4 minutes after the first appearance of the radioopaque marker in the duodenum. When iodide was instilled directly into the duodenum together with the radioopaque marker (two subjects), iodine was detected in saliva 3–4 minutes after the dose was administered. These observations suggest that the absorption of iodide in humans occurs primarily in the small intestine and that the stomach may play a minor role in iodide absorption. The mechanisms by which iodide is transported across the intestinal epithelium are not known. Iodide may be transported by

3. HEALTH EFFECTS

mechanisms that also transport chloride such as the $\text{Cl}^-/\text{HCO}_3^-$ antiport (Dalmark 1976; Lambert and Lowe 1978) or Cl^- channels (Katayama and Widdicombe 1991).

While the above studies implicate the small intestine as the major site of absorption of iodide in humans, studies in rats and dogs indicate that 14–30% of an oral dose of iodide may be absorbed in the stomach in these species (Small et al. 1961; Cohn 1932)

Distribution.

Iodide Transport. Uptake of iodide into the thyroid is facilitated by a membrane carrier in the basolateral membrane of the thyroid follicle cell (Carrasco 1993; Levy et al. 1998a; Shen et al. 2001). The carrier, or NIS, catalyzes the simultaneous transfer Na^+ and I^- across the basolateral membrane (Chambard et al. 1983; Iff and Wilbrandt 1963; Nilsson et al. 1990). The stoichiometry of transfer reaction is $(2)\text{Na}^+/(1)\text{I}^-$, which confers to the NIS a net positive charge and, therefore, a sensitivity to transmembrane voltage (Eskandari et al. 1997; O'Neill et al. 1987). In the presence of an inward-directed electrochemical gradient for Na^+ , the NIS can transfer I^- into the cell against a pronounced outward-directed electrochemical gradient for I^- (Takasu et al. 1984; Williams 1969; Woodbury and Woodbury 1963). This enables the follicle cell to achieve intracellular/extracellular concentration ratios of 10–50 for iodide (Andros and Wollman 1991; Bagchi and Fawcett 1973; Shimura et al. 1997; Vroye et al. 1998; Weiss et al. 1984a; Wolff 1964).

The NIS has been studied extensively in several *in vitro* preparations, including isolated plasma membrane vesicles of mammalian thyroid (O'Neil et al. 1987), FRTL-5 cells, a cell line derived from normal rat thyroid (Weiss et al. 1984a), *Xenopus laevis* oocytes transformed by intracellular injection of FRTL-5 RNA to express NIS (Eskandari et al. 1997), and other mammalian cells cultures transformed to express NIS (Levy et al. 1997; Nakamura et al. 1990; Smanik et al. 1996; Yoshida et al. 1997). The apparent K_m for I^- transport in cell systems is approximately 30–40 μM , which is considerably higher than the serum iodide concentration of 0.04–0.08 μM (5–10 $\mu\text{g/L}$) (Eskandari et al. 1997; Weiss et al. 1984a). The relatively high K_m enables the iodide transport rate to be highly sensitive to changes in plasma I^- concentration. Iodide transport by the NIS is inhibited by other anions, most notably, thiocyanate (SCN^-) and perchlorate (ClO_4^-) (Carrasco 1993; Wolfe 1964). Thiocyanate is one of several anions other than I^- that can be transported by the NIS, including SeCN^- , NO_3^- , ClO_3^- , Br^- , BF_4^- , IO_4^- , and BrO_3^- (Eskandari et al. 1997). Perchlorate, on the other hand, does not appear to be transported by NIS (Eskandari et al. 1997; Yoshida et al. 1997). Thus, thiocyanate and perchlorate, which both inhibit iodide uptake in thyroid *in vivo*, do so by different mechanisms; thiocyanate is a competitive substrate for transport, whereas perchlorate appears to block I^- binding to the NIS.

3. HEALTH EFFECTS

Synthesis of NIS is regulated by the pituitary hormone, TSH, which stimulates iodide uptake into the thyroid. The mechanism involves both increased transcription of the NIS gene and increased translation of mRNA for NIS (Kogai et al. 1997; Levy et al. 1997; Ohno et al. 1999; Pekary et al. 1998). Both responses to TSH follow binding of TSH to a receptor on the basolateral membrane and activation of the enzyme adenylate cyclase by GTP binding protein G_{α} (Akamizu et al. 1990; Chazenbalk et al. 1990; Kogai et al. 1997; Parmentier et al. 1989; Perret et al. 1990; Raspe and Dumont 1995). In FRTL-5 cells grown in the absence of TSH, NIS activity declines to a minimum level and can be restored by the addition of TSH to the medium or by treating the cells with dibutryl-cAMP or other agents that increase the intracellular concentration of cAMP (Pekary et al. 1998; Weiss et al. 1984a, 1984b). Thus, the actions of TSH appear to involve the activation of adenylate cyclase and subsequent increase in the intracellular concentration of cAMP.

Synthesis of NIS also appears to be regulated by plasma iodide concentration through a mechanism that does not involve directly TSH. In rats exposed to drinking water containing 500 mg/L I as sodium iodide, expression of mRNA for the NIS in the thyroid decreased by 45% after 1 day of exposure and 60% after 6 days of exposure compared to controls that ingested water without added iodide. Serum iodide concentrations were 150–200-fold higher in the exposed rats compared to controls, whereas the serum TSH concentrations were not different between control and treated groups (Eng et al. 1999). A similar observation was made in dogs made hypothyroid by treatment with propylthiouracil (an inhibitor of iodination of thyroglobulin) and perchlorate (Uytersprot et al. 1997). The hypothyroid state elevated TSH concentrations in serum; nevertheless, a single injection of 0.3 mg potassium iodide (0.23 mg I) resulted in decreased expression of NIS in the thyroid within 24–48 hours after the dose, without a change in TSH concentrations in serum.

The exact mechanisms by which the NIS gene transcription is regulated have not been determined. The gene in humans and rats has been sequenced, enabling studies of the mechanisms of gene transcription regulation (Dai et al. 1996; Smanik et al. 1996). The human gene resides on chromosome 19 (Smanik et al. 1997). Mutations in the gene sequence have been associated with hypothyroidism, goiter, and abnormally low thyroid uptake of injected iodide (Fujiwara et al. 1997, 1998; Kosugi et al. 1998; Levy et al. 1998c; Pohlenz and Refetoff 1999; Pohlenz et al. 1997). The 5'-flanking region of the rat NIS gene has been shown to contain one or more promoter regions; however, their role in regulation of the NIS transcription is not completely understood (Endo et al. 1997; Ohno et al. 1999; Tong et al. 1997). Ohno et al. (1999) found evidence for a promoter region in the rat NIS gene that appears to be respond to a rise in intracellular cAMP, most likely by binding a cAMP-inducible or cAMP-activated transcription factor. A promoter region in the rat NIS gene responsive to thyroid transcription factor 1 (TTF-1) has also been described (Endo et al. 1997). Tong et al. (1997) found evidence for a promoter region in the rat NIS gene that could be suppressed in cell cultures that were transformed with the oncogene PTC1. This may provide

3. HEALTH EFFECTS

a mechanism for the decreased expression of the NIS gene in thyroid papillary carcinomas and the decreased iodide uptake of some thyroid carcinomas (Smanik et al. 1996, 1997).

Several tissues in humans, other than thyroid, actively accumulate iodide; these include the mammary gland, salivary glands, and stomach (Brown-Gant 1961; Wolff 1983). These tissues can achieve intracellular/extracellular and/or transepithelial concentration ratios for I⁻ concentrations of 20–40. Transport of iodide in these tissues is inhibited by thiocyanate and perchlorate; however, transport activity is not responsive to TSH. Clinical cases of genetic absence or impaired iodide uptake in the thyroid coupled with low uptakes in saliva and gastric fluid suggest an involvement of an NIS mechanism in these tissues (Fujiwara et al. 1997, 1998; Kosugi et al. 1998; Leger et al. 1987; Pohlenz and Refetoff 1999; Pohlenz et al. 1997; Wolff 1983). Further evidence for extrathyroidal NIS comes from studies of mammary gland. The NIS gene is expressed in the mammary gland of both the human and the rat (Levy et al. 1997; Smanik et al. 1997). In the rat, expression of the NIS, or a structurally similar membrane protein, increases during nursing and decreases after weaning (Levy et al. 1998a).

Studies in animals have revealed other tissues that actively secrete or accumulate iodide transport by a mechanism that is inhibited by perchlorate and thiocyanate, suggestive of an active NIS. These include, choroid plexus, ciliary body of the eye, small intestine (ileum), ovary, placenta, and skin in mammals; and avian salt gland in marine birds (Brown-Grant 1961).

Iodothyronine Transport. Uptake of T₄ and T₃ into tissues occurs by a saturable, energy-dependent carrier transport system. Evidence for active transport derives from a variety of observations. The rate of uptake of T₃ into the perfused rat liver is proportional to the concentration of free T₃ in the perfusate and is not related to the total concentration or bound concentration (Mendel et al. 1988). The free cytosolic concentration of T₃ in the *in vivo* rat liver and heart muscle exceeds that of the simultaneous free concentration in plasma, suggesting uptake of T₃ into these tissues against a chemical gradient for T₃ (Oppenheimer and Schwartz 1985). T₃ uptake into confluent cultures of human or rat hepatoma cells is saturable, stereoselective for the active L enantiomer, temperature dependent, and inhibited by metabolic and membrane transport inhibitors, including phloretin (Movius et al. 1989; Topliss et al. 1989). Saturable, stereoselective, temperature-dependent, and energy-dependent uptake of T₃ and T₄ has also been observed in cultures of human fibroblasts and for T₃ in *in vitro* preparations of rat skeletal muscle (Centanni and Robbins 1987; Docter et al. 1987).

Metabolism.

Iodination in the Thyroid Gland. Iodination of thyroglobulin is catalyzed by thyroid peroxidase, a hemoprotein in the apical (luminal) membrane of thyroid follicle cells (Dunn and Dunn 2001). Thyroid

3. HEALTH EFFECTS

peroxidase catalyzes both the iodination of tyrosine residues in thyroglobulin and the coupling of the iodinated residues to form the thyroid hormones, T_4 and T_3 , and diiodotyrosine. The iodination reaction involves the oxidation of iodide (I^-) to a reactive species having a sufficiently high oxidation potential to iodinate the aromatic ring of tyrosine. The oxidizing agent in the reaction is hydrogen peroxide, which is generated at the apical membrane of follicle cells by an NADPH oxidase (Deme et al. 1994; Dupuy et al. 1991). Although the exact mechanism of the iodination reaction is not completely understood, three species are suspected as being candidates for the reactive iodinating species: a free radical (I^\bullet , iodinium (I^+), or an enzyme-bound hypoiodite ($[EOI^-]$) (Taurog 1996). Human thyroglobulin contains 134 tyrosyl residues, of which approximately 20 undergo iodination to yield approximately 2–4 molecules of T_4 or T_3 per molecule of thyroglobulin. The coupling reaction occurs within thyroglobulin, rather than as a reaction between free iodinated tyrosines. In the formation of T_4 , two molecules of diiodotyrosine are coupled, whereas the formation of T_3 is a coupling of moniodotyrosine and diiodotyrosine residues. The reaction is catalyzed by thyroid peroxidase with hydrogen peroxide serving as the oxidizing agent in the formation of a reactive intermediate of the contributing diiodotyrosine residue, possibly a free radical species (Taurog et al. 1994). Specificity of iodination and coupling of tyrosine residues within thyroglobulin is conferred, in part, by the specificity of thyroid peroxidase and, in part, by the structure of thyroglobulin (Taurog 1996).

The gene for human thyroid peroxidase has been isolated and sequenced (Kimura et al. 1987; Libert et al. 1987; Magnusson et al. 1987). Transcription of the gene is stimulated by TSH, possibly through a mechanism involving cAMP (McLachlan and Rapoport 1992).

Diiodination of Iodothyrones in Peripheral Tissues. Deiodination serves both as an important mechanism for the production of extrathyroidal T_3 and for the deactivation of the thyroid hormones, T_4 and T_3 . The deiodination reactions are catalyzed by selenium-dependent deiodinase enzymes (selenodeiodinases). Three selenodeiodinases have been described that differ in substrate preference, reaction products, response to inhibitors (propylthiouracil, gold), and response to T_3 (Table 3-7). Full activity of each enzyme requires selenocysteine in the amino acid sequence of the active site, which is the basis for deiodination activity being responsive to nutritional selenium status (Larsen and Berry 1994; see Section 3.9).

Excretion.

Urinary Excretion of Iodide. Urinary excretion normally accounts for >97% of the elimination of absorbed iodine. The renal plasma clearance of iodine has been measured in human subjects during continuous intravenous infusions of radioiodide (Bricker and Hlad 1955). Under these conditions, only a negligible amount of radioiodine in the plasma was associated with protein and >98% was ultrafilterable; thus, the renal clearance of radioiodine can be assumed to reflect that of radioiodide (Bricker and Hlad

3. HEALTH EFFECTS

Table 3-7. Properties of Human Iodothyronine Selenodeiodinases

Parameter	Type 1	Type 2	Type 3
Physiological role	Plasma T ₃ production, deactivate T ₃ and T ₄ , degrade rT ₃	Plasma and intracellular T ₃ production	Deactivate T ₃ and T ₄
Tissue location	Liver, kidney, thyroid, central nervous system, pituitary	Central nervous system, pituitary, brown fat, placenta, thyroid, skeletal muscle, heart	Central nervous system, placenta, skin
Substrate preference	rT ₃ >> T ₄ > T ₃	T ₄ > rT ₃	T ₃ > T ₄
Molecular weight (D) ^a	29,000	35,000	31,500
Apparent K _m (M)	~10 ⁻⁷ (rT ₃) ~10 ⁻⁶ (T ₄)	10 ⁻⁹ (T ₄) ~10 ⁻⁸ (rT ₃)	~10 ⁻⁹ (T ₃) ~10 ⁻⁸ (T ₄)
Deiodination site	Outer and inner ring	Outer ring	Inner ring
Apparent K _i (M)			
Propylthiouracil	2x10 ⁻⁷	4x10 ⁻³	10 ⁻³
Gold	~5x10 ⁻⁹	~2x10 ⁻⁶	5x10 ⁻⁶
Response to T ₃	Increase	Decrease	Increase

Source: Larsen et al. 1998

^aMonomer

T₃ = 3,5,3Ntriodo-L-thyronine; T₄ = 3,5,3N5Ntetraiodo-L-thyronine (thyroxine); rT₃ = reverse T₃

3. HEALTH EFFECTS

1955; Walser and Rahill 1965). Under steady-state conditions with respect to the serum radiiodine concentration, the renal plasma clearance of radioiodine was approximately 30% of the glomerular filtration rate, suggesting that filtered iodide is reabsorbed in the renal tubule. Measurements of the steady-state renal clearance of radioiodide in dogs have provided additional evidence for tubular reabsorption of iodide (Beyer et al. 1981; Walser and Rahill 1965). The mechanism of renal tubular reabsorption of iodide has not been elucidated, although studies to examine mechanisms have been largely limited to clearance studies. In humans, iodide clearance as a fraction of the glomerular filtration rate (C_I/GFR) increases in response to an acute increase in GFR and decreases in response to an acute decrease in GFR; however, C_I/GFR is relatively unaffected by large acute increases in the plasma concentration of radioiodine at a constant GFR (Bricker and Hlad 1955). This suggests a sensitivity of tubular reabsorption to both filtered load of iodide and tubular flow rate. C_I/GFR can be increased to near unity during mannitol-induced diuresis (Bricker and Hlad 1955). Although the inability to detect an apparent saturation of tubular reabsorption at high filtered loads of iodide, and the sensitivity of tubular reabsorption to tubular flow rate, are consistent with a passive, paracellular, component to iodide reabsorption, these observations do not rule out the existence of facilitated transport of iodide in the nephron. In humans, C_I/GFR , whole body clearance of radioiodine is increased during diuresis induced by furosemide and hydrochlorothiazide, two clinical diuretics that decrease sodium and chloride reabsorption in the in the loop of Henle and distal convoluted tubule, suggesting the possibility of reabsorption of iodide in distal segments of the nephron (Seabold et al. 1993). This observation is further supported by steady-state clearance measurements in dogs, in which C_I/GFR was found to increase in response to hydrochlorothiazide-induced diuresis, and to be lower, near that of C_{Cl}/GFR , in dogs that had been maintained on a sodium deprivation diet (Beyer et al. 1981; Walser and Rahill 1965). The latter observation would suggest that adaptations to sodium deprivation that result in greater reabsorption of sodium in the late distal nephron also give rise to increased reabsorption of iodide.

3.5.2 Mechanisms of Toxicity

The mechanism by which excess iodide produces hypothyroidism is not completely understood. Iodide excess inhibits the iodination of thyroglobulin in the thyroid gland and inhibits the release of T_4 and T_3 from the gland (Pisarev and Gärtner 2000). Both effects could contribute to stimulation of release of TSH from the pituitary gland and to the increase in serum concentration of TSH and hypertrophy of the thyroid gland that has been shown to accompany iodide-induced thyroid gland suppression (see Section 3.2.2.2, Endocrine). The mechanism by which iodide suppresses iodination and thyroid hormone release appears to involve inhibition of adenylate cyclase. The stimulatory actions of TSH on the thyroid gland, which include increased iodide transport, and increased iodination of thyroglobulin and production and release of T_4 and T_3 , occur in response to a rise in intracellular cAMP levels that follow binding of TSH to TSH receptors on thyroid gland follicle cells. Iodide inhibits adenylate cyclase in thyroid gland follicle cells

3. HEALTH EFFECTS

and decreases the TSH-induced rise in intracellular cAMP. However, the effect of iodide on adenylate cyclase can be prevented by inhibitors of iodination, such as propylthiouracil. This has led to the suggestion that the ultimate active inhibitor is an endogenous iodinated species that is produced in a reaction requiring thyroid peroxidase. Candidates for the endogenous inhibitor are one or more iodinated lipids (Filetti and Rapoport 1983; Pereira et al. 1990; Pisarev and Gärtner 2000). The synthesis of NIS also appears to be regulated by plasma iodide concentration, through a mechanism that does not directly involve TSH. In rats and dogs, expression of mRNA for the NIS in the thyroid decreased when serum iodide concentrations were increased by ingestion or injection of iodide, even when serum TSH concentrations were unchanged (Eng et al. 1999; Uyttensprot et al. 1997).

Excess iodide intake may be a contributing factor in the development of autoimmune thyroiditis in people who are susceptible (Brown and Bagchi 1992; Foley 1992; Rose et al. 1997; Safran et al. 1987). In certain inbred strains of rats and mice, exposure to iodide has been shown to increase the incidence of lymphocytic thyroiditis (Allen and Braverman 1990; Allen et al. 1986; Noble et al. 1976; Rasooly et al. 1996). The mechanism by which iodide stimulates autoimmunity is not completely understood. In the inbred mouse strain, NODh^{h4}, both CD4⁺ and CD8⁺ T cells are required for iodine-induced acceleration of autoimmunity (Hutchings et al. 1999). Highly iodinated thyroglobulin may be an antigen in susceptible animals (or humans) (Rose et al. 1997; Saboori et al. 1998a, 1998b, 1999; Sundick et al. 1987). Other proposed mechanisms include effects of iodine on the regulation of major histocompatibility class I and increased expression of thyroid gland TNF- α (Roti and Vagenakis 2000; Ruwhof and Drexhage 2001; Verma et al. 2000). Thyroid autoimmunity may produce hypothyroidism by stimulating thyroid cell apoptosis (Huang and Kukes 1999; Phelps et al. 2000; Stassi et al. 2000).

Excess iodide can, under certain circumstances, induce hyperthyroidism and thyrotoxicosis; this has been observed most often after iodine supplementation of iodine-deficient populations (Braverman and Roti 1996; Fradkin and Wolff 1983; Leger et al. 1984; Paschke et al. 1994). The mechanism by which iodide induces hyperthyroidism is not completely understood. Chronic iodine deficiency results in thyroid gland proliferation, which may increase the fixation of mutations in the gland and promote the development of autonomous nodules, that are less responsive or unresponsive to regulation in response to serum TSH concentrations. Iodine excess, under these conditions, could result in increased and unregulated thyroid hormone production (Corvilain et al. 1998; Dremier et al. 1996; Roti and Uberti, 2001).

3.5.3 Animal-to-Human Extrapolations

The principal health effects of iodine in humans have been characterized in experimental, clinical, and epidemiological studies of humans. Animal models remain useful for exploring mechanisms, and where relevant, these studies have been described; for example, the use of inbred rat strains to study iodine-

3. HEALTH EFFECTS

induced autoimmune thyroiditis (see Section 3.2.2.2, Endocrine). The major features of the toxicokinetics of iodine in humans, particularly following oral exposures, have been characterized in experimental and clinical studies of humans. A substantial amount of experience exists in the application of biomarkers for assessing human exposures to iodine (e.g., urinary iodine excretion and thyroid scintillation scan) and health effects in humans (e.g., serum thyroid hormone, TSH, and thyroid antibodies). Thus, the assessment of health effects and health risks associated with exposures to iodine or radioiodine can be based soundly on human studies rather than on extrapolations from animal studies.

3.6 ENDOCRINE DISRUPTION

Recently, attention has focused on the potential hazardous effects of certain chemicals on the endocrine system because of the ability of these chemicals to mimic or block endogenous hormones, or otherwise interfere with the normal function of the endocrine system. Chemicals with this type of activity are most commonly referred to as endocrine disruptors. Some scientists believe that chemicals with the ability to disrupt the endocrine system are a potential threat to the health of humans, aquatic animals, and wildlife. Others believe that endocrine disrupting chemicals do not pose a significant health risk, particularly in light of the fact that hormone mimics exist in the natural environment. Examples of natural hormone mimics are the isoflavinoid phytoestrogens (Adlercreutz 1995; Livingston 1978; Mayr et al. 1992). These compounds are derived from plants and are similar in structure and action as endogenous estrogen. While there is some controversy over the public health significance of endocrine disrupting chemicals, it is agreed that the potential exists for these compounds to affect the synthesis, secretion, transport, binding, action, or elimination of natural hormones in the body that are responsible for the maintenance of homeostasis, reproduction, development, and/or behavior (EPA 1997). As a result, endocrine disruptors may play a role in the disruption of sexual function, immune suppression, and neurobehavioral function. Endocrine disruption is also thought to be involved in the induction of breast, testicular, and prostate cancers, as well as endometriosis (Berger 1994; Giwercman et al. 1993; Hoel et al. 1992).

Iodine is an endocrine disruptor in that the principal direct effects of excessive iodine ingestion are on the thyroid gland and on the regulation of thyroid hormone production and secretion. As discussed in Section 3.2.2.2, Endocrine Effects, the effects of iodine on the thyroid gland include hypothyroidism, hyperthyroidism, and thyroiditis. The above three types of effects can occur in children and adults, and in infants exposed *in utero*, or during lactation. Adverse effects on the pituitary and adrenal glands derive secondarily from disorders of the thyroid gland. A wide variety of effects on other organ systems can result from disorders of the thyroid gland, including disturbances of the skin, cardiovascular system, pulmonary system, kidneys, gastrointestinal tract, liver, blood, neuromuscular system, central nervous system, skeleton, male and female reproductive systems, and numerous endocrine organs, including the pituitary and adrenal glands (Braverman and Utiger 2000).

3. HEALTH EFFECTS

3.7 CHILDREN'S SUSCEPTIBILITY

This section discusses potential health effects from exposures during the period from conception to maturity at 18 years of age in humans, when all biological systems will have fully developed. Potential effects on offspring resulting from exposures of parental germ cells are considered, as well as any indirect effects on the fetus and neonate resulting from maternal exposure during gestation and lactation. Relevant animal and *in vitro* models are also discussed.

Children are not small adults. They differ from adults in their exposures and may differ in their susceptibility to hazardous chemicals. Children's unique physiology and behavior can influence the extent of their exposure. Exposures of children are discussed in Section 6.6 Exposures of Children.

Children sometimes differ from adults in their susceptibility to hazardous chemicals, but whether there is a difference depends on the chemical (Guzelian et al. 1992; NRC 1993). Children may be more or less susceptible than adults to health effects, and the relationship may change with developmental age (Guzelian et al. 1992; NRC 1993). Vulnerability often depends on developmental stage. There are critical periods of structural and functional development during both prenatal and postnatal life and a particular structure or function will be most sensitive to disruption during its critical period(s). Damage may not be evident until a later stage of development. There are often differences in pharmacokinetics and metabolism between children and adults. For example, absorption may be different in neonates because of the immaturity of their gastrointestinal tract and their larger skin surface area in proportion to body weight (Morselli et al. 1980; NRC 1993); the gastrointestinal absorption of lead is greatest in infants and young children (Ziegler et al. 1978). Distribution of xenobiotics may be different; for example, infants have a larger proportion of their bodies as extracellular water and their brains and livers are proportionately larger (Altman and Dittmer 1974; Fomon 1966; Fomon et al. 1982; Owen and Brozek 1966; Widdowson and Dickerson 1964). The infant also has an immature blood-brain barrier (Adinolfi 1985; Johanson 1980) and probably an immature blood-testis barrier (Setchell and Waites 1975). Many xenobiotic metabolizing enzymes have distinctive developmental patterns. At various stages of growth and development, levels of particular enzymes may be higher or lower than those of adults, and sometimes unique enzymes may exist at particular developmental stages (Komori et al. 1990; Leeder and Kearns 1997; NRC 1993; Vieira et al. 1996). Whether differences in xenobiotic metabolism make the child more or less susceptible also depends on whether the relevant enzymes are involved in activation of the parent compound to its toxic form or in detoxification. There may also be differences in excretion, particularly in newborns who all have a low glomerular filtration rate and have not developed efficient tubular secretion and resorption capacities (Altman and Dittmer 1974; NRC 1993; West et al. 1948). Children and adults may differ in their capacity to repair damage from chemical insults. Children also have a longer remaining lifetime in which to express damage from chemicals; this potential is particularly relevant to cancer.

3. HEALTH EFFECTS

Certain characteristics of the developing human may increase exposure or susceptibility, whereas others may decrease susceptibility to the same chemical. For example, although infants breathe more air per kilogram of body weight than adults breathe, this difference might be somewhat counterbalanced by their alveoli being less developed, which results in a disproportionately smaller surface area for alveolar absorption (NRC 1993).

Children are highly vulnerable to radioiodine toxicity and related thyroid cancers (NRC 1999).

Radioiodine is secreted into milk in humans, cows and goats, and infants and children ingest a larger amount of milk per unit of body mass than adults; they also absorb ingested iodine as avidly as adults. As a result, children exposed to milk that has been contaminated with radioiodine may receive a larger internal dose of radioiodine than similarly exposed adults. This larger absorbed iodine dose per unit of body mass is concentrated in a smaller thyroid mass in infants and children (Aboul-Khair et al. 1966; Kay et al. 1966; Mochizuki et al. 1963), which can result in a higher radiation dose per unit of thyroid mass.

In addition to a smaller thyroid mass, thyroid iodine uptakes, expressed as a fraction of absorbed dose, are 3–4 times higher during the first 10 days of postnatal life compared to adult uptakes and decline to adult levels after approximately age 10–14 days (Fisher et al. 1962; Kearns and Phillipsborn 1962; Morrison et al. 1963; Ogborn et al. 1960; Van Middlesworth 1954). As a result, newborn infants will be particularly vulnerable to high radiation doses from internal exposure to radioiodine. NCI (1997) estimated that the radiation dose (rad) to the thyroid gland resulting from ingestion of 1 μCi of ^{131}I activity would increase with decreasing age in children from approximately 1.5 rad/ μCi in adults, to approximately 6.6 rad/ μCi at 5 years, 12 rad at 1 year, and 33 rad in newborn infants. Another important factor that contributes to higher vulnerability of children is that children under 15 years of age appear to be more susceptible to developing thyroid tumors from thyroid irradiation (Wong et al. 1996). Studies of thyroid cancers and external radiation exposure have found a strong age dependence between thyroid radiation dose and thyroid cancer. Risk is substantially greater for radiation doses received prior to age 15 years when compared to risks for doses received at older ages (Ron et al. 1995). An age-dependence has been found for solid tumors of other organs and external radiation dose (Thompson et al. 1994). This same general trend in age-dependence would be expected for internal exposures to radioiodine; thus, studies of adult exposures to radioiodine may not be directly applicable to predicting outcomes from exposures to children.

Evidence for vulnerability of infants and children to radioiodine toxicity derive from studies of populations that have been exposed to radioiodine fall-out as a result of thermonuclear bomb tests and nuclear reactor accidents. Several epidemiological studies have examined thyroid gland disorders in residents of the Marshall Islands who were exposed to radioiodine from atmospheric fallout after an atmospheric nuclear bomb test (so-called BRAVO test). The exposures occurred as a result of an unexpected change in the wind direction after the bomb detonation. Residents of several islands near and downwind from the test

3. HEALTH EFFECTS

site on Bikini Atoll (e.g., Ailingnae, Rongelap, Utirik) were exposed to both internal radioiodine and external gamma radiation from fallout during the 2 days prior to their evacuation. The estimated gamma radiation dose on these islands ranged from 69 to 175 rad (0.7–1.75 Gy) or approximately 10–50% of the estimated thyroid dose (Conard 1984; Hamilton et al. 1987; Howard et al. 1997; Takahashi et al. 1999). Cases of thyroid gland disorders began to be detected in the exposed population in approximately 10 years after the exposure, particularly in persons who were exposed as children; these included cases of apparent growth retardation, myxedema, and thyroid gland nodules and neoplasms (Conard et al. 1970). In 1981, health screening of children on Rongelap revealed an 83% prevalence of elevated serum concentrations of TSH (>5 mU/L) among exposed children who were 1 year old or less at the time of the BRAVO test and who received an estimated thyroid radiation dose exceeding 1,500 rad (15 Gy). Prevalence decreased with exposure age and/or thyroid dose: 25% for ages 2–10 years (800–1,500 rad, 8–15 Gy) and 9% for ages >10 years (335–800 rad, 3.3–8 Gy). A similar age-related prevalence of thyroid abnormalities occurred after radioiodine release from the fire at the Chernobyl nuclear power plant in the Ukraine. Clinical records from the Republics of Belarus and Ukraine show an increase in the incidence of thyroid nodules and thyroid cancers in children and adolescents, which became apparent approximately 4 years after the release of radioactive materials from the Chernobyl nuclear power plant in April 1986 (Astakhova et al. 1998; Cherstvoy et al. 1996; Drobyshevskaya et al. 1996; Tronko et al. 1996). A comparison of thyroid cancers diagnosed in children in the Belarus-Ukraine region after the Chernobyl fire with thyroid cancers diagnosed in children in France and Italy during the same period revealed a striking age difference (Pacini et al. 1997). Most the Belarus-Ukraine cancers were diagnosed at age 5 years or less, whereas most of the cases in France and Italy were diagnosed after age 14 years. This observation is consistent with a radioiodine contribution to the Belarus-Ukraine cancers and a higher vulnerability of infants to radioiodine toxicity.

Nutritional factors can affect the toxicokinetics of iodine in children and adults. The most important factor is dietary iodine. Chronic iodine deficiency triggers homeostatic mechanisms to increase iodide uptake into the thyroid gland in order to sustain adequate thyroid hormone levels to regulate metabolism (Delange and Ermans 1996). These mechanisms include induction of iodide transport activity and iodination activity in the thyroid gland, as well as hypertrophy of the gland (i.e., goiter). As a result, exposures to radioiodine that occur during a state of deficiency can be expected to result in a larger fraction of the radioiodine dose being deposited in the thyroid gland, which could result in a higher radiation dose and risk.

Another nutritional factor that could potentially affect iodine biokinetics in infants and children is selenium deficiency. Selenium is a cofactor in the iodothyronine deiodinases that are important for the synthesis of the thyroid hormone, T₃, in extrathyroidal tissues. Iodine deficiency, in conjunction with selenium deficiency, has been associated with goiter and cretinism, a developmental impairment related to

3. HEALTH EFFECTS

prenatal hypothyroidism (Goyens et al. 1987; Vanderpas et al. 1990). In this state, in which the thyroid gland is responding to a deficiency in T_3 production by increasing iodide transport and iodination activity in the thyroid gland, infants and children (as well as adults) may experience a higher thyroid uptake of absorbed iodine, and possibly a higher radiation dose to the thyroid when exposed to radioiodine.

As previously discussed in Section 3.4.2.2, exposure to iodine can begin *in utero* with maternal exposure and, as a result, the fetus is vulnerable to the potential toxic effects of maternal iodine exposures that occur during pregnancy. Maternal exposures to excess iodine have been shown to produce thyroid enlargement and hypothyroidism in neonates (Coakley et al. 1989; Hassan et al. 1968; Iancu et al. 1974; Martin and Reno 1962; Penfold et al. 1978; Vicens-Colvet et al. 1998). Deaths have occurred in neonates as a result of tracheal compression from thyroid gland enlargement (Galina et al. 1962). The vulnerability of the fetal thyroid gland has a toxicokinetic basis. Radioiodine uptake in the fetal thyroid commences in humans at approximately 70–80 days of gestation and precedes the development of thyroid follicles and follicle colloid, which are generally detectable at approximately 100–120 days of gestation (Book and Goldman 1975; Evans et al. 1967). Fetal iodide uptake activity increases with the development of the fetal thyroid and reaches its peak at approximately 6 months of gestation, at which point, the highest concentrations in the thyroid are achieved, approximately 5% of the maternal dose/g fetal thyroid (approximately 1% of the maternal dose) (Aboul-Khair et al. 1966; Evans et al. 1967). Fetal radioiodine concentrations 1–2 days following a single oral maternal dose of radioiodine generally exceed the concurrent maternal thyroid concentration by a factor of 2–8, with the highest fetal/maternal ratios occurring at approximately 6 months of gestation (Book and Goldman 1975). Following exposure to ^{131}I from maternal ingestion of medically administered radioiodine or from repeated exposure to radioactive fallout, the fetal/maternal ratio for thyroid radioiodine concentration has been estimated to be approximately 2–3 (Beierwaltes et al. 1963; Book and Goldman 1975; Eisenbud et al. 1963).

Dermal exposures to iodine, in particular topical antiseptics containing povidone-iodine, can expose the fetus to iodine. For example, increases in iodine concentration in maternal urine and umbilical cord blood have been observed in pregnant women who received dermal or vaginal applications of povidone-iodine prior to delivery for disinfection of the skin and fetal scalp electrodes, suggesting that absorption of iodine occurs with these uses of povidone-iodine as well (l'Allemand et al. 1983; Bachrach et al. 1984). Consistent with this are observations that topical application of iodine preparations (i.e., povidone-iodine) during labor has produced thyroid gland suppression in newborns (l'Allemand et al. 1983; Novaes et al. 1994). Infants can also absorb iodine when such iodine preparations are applied topically. Use of povidone-iodine for topical and surgical wound disinfection in infants has been shown to induce transient hypothyroidism or hyperthyroidism (Brown et al. 1997; Chabrolle and Rossier 1978a, 1978b).

3. HEALTH EFFECTS

Nursing infants can be exposed to iodine in breast milk (Dydek and Blue 1988; Hedrick et al. 1986; Lawes 1992; Morita et al. 1998; Robinson et al. 1994; Rubow et al. 1994; Spencer et al. 1986). The level of exposure will depend not only on the maternal exposure, but also on the physiologic status of the maternal thyroid. A larger fraction of the absorbed dose is excreted in breast milk in the hypothyroid state compared to the hyperthyroid state; in the hypothyroid state, excretion of radioiodine into breast milk can be 10 times higher (e.g., 25% of the dose) than in euthyroid or hyperthyroid states (Hedrick et al. 1986; Morita et al. 1998; Robinson et al. 1994).

Iodine is not stored in skeletal tissue or fat to any significant degree and thus, mobilization of these tissues during pregnancy, for production of the fetal skeleton or breast milk, would not be expected to contribute to fetal or infant exposure. There is no evidence that iodine metabolism would be appreciably different in children compared to adults. It is possible that the conjugation of iodothyronines with glucuronic acid could be limited in newborns as a result of the normal development of glucuronyltransferase activity in the newborn and infant; however, there is no evidence for an effect on iodine toxicokinetics. In the Gunn rat, which is a strain of rat that is deficient in glucuronyltransferase activity, glucuronic acid conjugates of iodothyronines are formed and biliary excretion of iodothyronines is impaired; however, normal circulating levels iodothyronine appear to be maintained (Curran and DeGroot 1991). This would suggest that the thyroid gland may not increase uptake of iodine in response to an impairment in glucuronyltransferase activity.

Models of the biokinetics of iodine in infants, children, adolescents, and adults have been developed by ICRP (1989, 1994a, 1995). Models have also been developed that predict, with reasonably high accuracy, the accumulation of radioiodide in the thyroid gland of infants and children exposed to single doses of radioiodine for clinical procedures (Fisher et al. 1962).

3.8 BIOMARKERS OF EXPOSURE AND EFFECT

Biomarkers are broadly defined as indicators signaling events in biologic systems or samples. They have been classified as markers of exposure, markers of effect, and markers of susceptibility (NAS/NRC 1989).

Due to a nascent understanding of the use and interpretation of biomarkers, implementation of biomarkers as tools of exposure in the general population is very limited. A biomarker of exposure is a xenobiotic substance or its metabolite(s) or the product of an interaction between a xenobiotic agent and some target molecule(s) or cell(s) that is measured within a compartment of an organism (NAS/NRC 1989). The preferred biomarkers of exposure are generally the substance itself or substance-specific metabolites in readily obtainable body fluid(s), or excreta. However, several factors can confound the use and interpretation of biomarkers of exposure. The body burden of a substance may be the result of exposures

3. HEALTH EFFECTS

from more than one source. The substance being measured may be a metabolite of another xenobiotic substance (e.g., high urinary levels of phenol can result from exposure to several different aromatic compounds). Depending on the properties of the substance (e.g., biologic half-life) and environmental conditions (e.g., duration and route of exposure), the substance and all of its metabolites may have left the body by the time samples can be taken. It may be difficult to identify individuals exposed to hazardous substances that are commonly found in body tissues and fluids (e.g., essential mineral nutrients such as copper, zinc, and selenium). Biomarkers of exposure to iodine are discussed in Section 3.8.1.

Biomarkers of effect are defined as any measurable biochemical, physiologic, or other alteration within an organism that, depending on magnitude, can be recognized as an established or potential health impairment or disease (NAS/NRC 1989). This definition encompasses biochemical or cellular signals of tissue dysfunction (e.g., increased liver enzyme activity or pathologic changes in female genital epithelial cells), as well as physiologic signs of dysfunction such as increased blood pressure or decreased lung capacity. Note that these markers are not often substance specific. They also may not be directly adverse, but can indicate potential health impairment (e.g., DNA adducts). Biomarkers of effects caused by iodine are discussed in Section 3.8.2.

A biomarker of susceptibility is an indicator of an inherent or acquired limitation of an organism's ability to respond to the challenge of exposure to a specific xenobiotic substance. It can be an intrinsic genetic or other characteristic or a preexisting disease that results in an increase in absorbed dose, a decrease in the biologically effective dose, or a target tissue response. If biomarkers of susceptibility exist, they are discussed in Section 3.10 "Populations That Are Unusually Susceptible".

3.8.1 Biomarkers Used to Identify or Quantify Exposure to Iodine

Urinary iodine excretion provides a reliable biomarker of steady state iodine intake. Under steady state conditions, in which exposure to iodine has been reasonably constant for at least 6 months, daily iodine will approximate the 24-hour urinary iodine excretion. The basis for this relationship is that ingested iodide is nearly completely absorbed in the gastrointestinal tract and that urine is the principal route of excretion of the absorbed iodide (see Sections 3.3.1.2 and 3.3.4.2). The use of urinary iodide as a biomarker of iodide exposure is supported by studies in which 24-hour urinary iodide was measured before and after supplementation. For example, 31 patients received oral supplements of 382 μg I/day for 6 months. Prior to the supplementation, the mean 24-hour urinary iodide excretion rate was 36 $\mu\text{g}/\text{day}$ (range, 13–69), whereas after 6 months of iodide supplementation, the mean 24-hour urinary iodide excretion rate was 415 $\mu\text{g}/\text{day}$ (Kahaly et al. 1998). The difference between these two values, 379 $\mu\text{g}/\text{day}$, is nearly identical to the supplemental dose of 382 $\mu\text{g}/\text{day}$.

3. HEALTH EFFECTS

Exposure to ^{123}I , ^{124}I , and ^{131}I can be detected directly from external measurements of gamma radiation emanating from the thyroid gland. The basis for this is that approximately 90% of the iodine in the body is in the thyroid gland and absorbed iodine is rapidly taken up into the thyroid gland. The measurement procedure is known as a thyroid scintillation scan. A scintillation detector device usually consists of a shielded sodium iodide crystal connected to a collimator and spectrometer. The detector is placed over the thyroid gland and the spectrometer is tuned to collect gamma emissions having peak energies of the target isotope (e.g., 0.159, 0.511, or 0.364 MeV for ^{123}I , ^{124}I , or ^{131}I , respectively). Events are corrected for attenuation by overlying tissue by counting a neck phantom containing a gamma source of known activity. Because of the relatively short radioactive decay half-times of ^{123}I (13 hours), ^{124}I (4.2 days), and ^{131}I (8 days), thyroid scans must be conducted soon after exposure in order to detect the iodine in the thyroid gland.

3.8.2 Biomarkers Used to Characterize Effects Caused by Iodine

The thyroid gland is the primary and most sensitive target for both chemical and radioiodine toxicity. As a result, biomarkers of iodine effects are those that allow the detection of preclinical and clinical suppression or stimulation of the thyroid gland. Effects on the thyroid gland can be classified into five types: goiter, hypothyroidism, hyperthyroidism, thyroiditis, and thyroid nodules. Hypothyroidism refers to a state of suppressed production and/or secretion of thyroid hormones and can occur with or without goiter, a functional hypertrophy of the gland in response to suppressed hormone production. The term clinical hypothyroidism, regardless of the cause, refers to a condition in which the circulating levels of T_4 and/or T_3 are depressed below their normal ranges and TSH is elevated above the normal range. Typical normal ranges are for hormone levels are shown in Table 3-8. The term subclinical hypothyroidism refers to a decrease in circulating T_4 or T_3 concentrations, usually accompanied by an increase in serum TSH concentration, within their respective normal ranges. Hyperthyroidism is an excessive production and/or secretion of thyroid hormones. The clinical manifestation of abnormally elevated circulating levels of T_4 and/or T_3 is thyrotoxicosis. The terms subclinical and clinical hyperthyroidism refer to the conditions in which the circulating levels of T_4 or T_3 are elevated within or above their normal ranges, respectively (Table 3-8). Thyroiditis refers to an inflammation of the gland, which is often secondary to thyroid gland autoimmunity. Thyroid autoimmunity can be detected as a presence of IgG antibodies to thyroglobulin and thyroid peroxidase in serum antibodies (Table 3-8). In addition to the above measurements, physical examination and ultrasound can reveal nodules and other normal or abnormal variations in thyroid gland structure. Examples of the use of these measurements in assessing iodine-induced effects on the thyroid gland are presented in Section 3.2 of the profile.

3. HEALTH EFFECTS

Table 3-8. Typical Reference Ranges for Serum Thyroid Hormones and TSH in Humans

Hormone	Reference range	
	Metric	SI unit
Total T ₄	4–11 µg/dL	60–140 nM ^a
Free T ₄	0.7–2.1 ng/dL	10–25 pM ^a
Total T ₃	75–175 ng/dL	1.1–2.7 nM ^a
Free T ₃	0.2–0.5 ng/dL	3–8 pM
Reverse T ₃	15–45 ng/dL	0.2–0.7 nM
TSH	0.3–4.0 mU/L ^{b,c}	1–15 pM
Thyroid peroxidase antibodies (TPA)	<10 IU/mL	–
Thyroglobulin autoantibodies (Tg-ab)	<10 IU/mL	–

Source: Stockigt (2000) and Marcocci and Chiovato (2000)

^aChildren may be higher

^bAssumes a biologic potency of 7–15 mU/mg

^cHigher in neonates (de Zegher et al. 1994)

T₃ = 3,5,3Ntriiodo-L-thyronine; T₄ = 3,5,3N5Ntetraiodo-L-thyronine (thyroxine); TSH = thyroid stimulating hormone

3. HEALTH EFFECTS

3.9 INTERACTIONS WITH OTHER CHEMICALS

Thiourelenes and Thionamides. A variety of compounds that contain the thionamide chemical group have been shown to increase the accumulation of iodide in the thyroid gland and to decrease the production of iodothyronines (Green 1996):

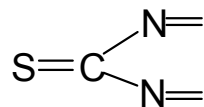

These include several drugs used in the treatment of thyrotoxicosis and other hyperthyroid states, (carbimazole, methimazole, and propylthiouracil); as well as the antibiotic, ethionamide; the cancer chemotherapy agent, 6-mercaptopurine; and goitrin, a natural constituent of the plant genus Brassicaceae (rutabaga, turnip, and cabbage). The thionamides exert their effects by inhibiting the iodination of tyrosine and monoiodotyrosine in the thyroid gland and the coupling of iodotyrosines to form iodothyronines. The mechanisms for these effects are not completely understood; however, at least two mechanisms are needed to explain the reversible and irreversible inhibition of iodothyronine production that is characteristic of these agents. Thionamides agents may act reversibly by reducing I^+ or some other reactive intermediate of iodine required in the iodination reaction, and also through a mechanism that involves a direct, irreversible reaction with thyroid peroxidase.

Thiouracil and propylthiouracil, and related thiourelenes, are also inhibitors of iodothyronine deiodinase (Leonard and Koehle 1996). The mechanism of inhibition involves the formation of a covalent complex with deiodinase enzymes. Inhibitory potency is highest for Type 1 deiodinase (Table 3-7). The result of inhibition is a decreased metabolic clearance of iodothyronines.

Aniline Derivatives. As a class, para-substituted aminobenzenes have activity similar to that of the thionamides in that they increase the accumulation of iodide in the thyroid gland and decrease production of iodothyronines, although possibly not through the same mechanisms (Green 1996). The group includes several drugs (and drug classes), amphenone B, carbutamide, amino-glutethimide, p-aminosalicylic acid, and the sulfonamides.

Substituted Phenols. Various substituted phenols that have hydroxyl groups in the meta positions have been shown to increase thyroid iodide accumulation and to inhibit iodothyronine production in the thyroid. These include resorcinol, 2,4-dihydroxybenzoic acid, and 2,4-dihydroxyphenol. These compounds exert their activity by producing an irreversible inhibition of thyroid peroxidase (Green 1996).

3. HEALTH EFFECTS

Hydroxypyridines. Hydroxypyridines, including 3-hydroxypyridine and 3,4-dihydroxypyridine, have been shown to increase thyroid iodide accumulation and to inhibit iodothyronine production in the thyroid (Green 1996).

Perchlorate and Related Complex Anions. A variety of complex inorganic anions have been shown to decrease the uptake of iodide in the thyroid gland. When given at high enough dosages, these agents can induce hypothyroidism and goiter (Green 1996). The complex anions include, in order of potency: perchlorate (ClO_4^-), perrhenate (ReO_4^-), pertechnetate (TcO_4^-), and tetrafluoroborate (BF_4^-). The mechanism for their activity is competitive inhibition of the NIS (Carrasco 1993; Eskandari et al. 1997; Wolf 1964). These agents are also transported by the NIS and are accumulated in the gland. They can also affect accumulation and/or secretion of iodide in other tissues that have an active iodide transporter, including the choroid plexus, gastric mucosa, mammary gland, placenta, salivary gland, and sweat gland (Brown-Gant 1961).

Thiocyanate. Thiocyanate (SCN^-) is a potent inhibitor of iodide uptake in the thyroid gland and iodination of thyroglobulin. The mechanism for the effect on iodide uptake is primarily related to competitive inhibition of iodide transport by the Na^+/I^- symport in thyroid gland; however, thiocyanate may also accelerate iodide efflux from the thyroid by being a substrate with iodide for an anion exchange mechanism on the basolateral membrane of thyroid follicle cells (Eskandari et al. 1997; Yoshida et al. 1997). Thiocyanate inhibits iodination, apparently by its actions as a competitive oxidation substrate for thyroid peroxidase (Virion et al. 1980). Unlike other complex anion inhibitors of iodide transport, thiocyanate is not accumulated in the thyroid gland.

Thiocyanate is a product of the metabolism of cyanide (ATSDR 1997) to which humans are exposed when they smoke cigarettes, which has prompted interest in the potential effects of smoking on thyroid iodine metabolism and thyroid disease (Bertelsen and Hegedus 1994). Thiocyanate is a metabolite of nitroprusside, a drug used in the treatment of acute hypertensive emergencies and cardiac failure. Impairment of thyroid function in patients on nitroprusside has been reported (Bodigheimer et al. 1979; Nourok et al. 1964).

Microsomal Enzyme Inducers. Agents that induce hepatic microsomal enzymes increase the activity of phenolic glucuronyl transferases that catalyze the conjugation of iodothyronines with glucuronic acid (Curran and DeGroot 1991; Visser 1990). Induction of glucuronyltransferase increases the metabolic clearance of iodothyronines and, if sufficiently accelerated, can stimulate thyroid stimulating hormone release and goiter. Such effects have been observed in rats and other experimental animal models in response to exposures to 2,4-benzopyrene, chlordane, DDT and DDD, 3-methylcholanthrene, PCBs, chlorinated dibenzodioxins (CDDs), and toxaphene. A variety of drugs have also been shown to exert

3. HEALTH EFFECTS

effects on glucuronide conjugation of iodothyronines, including the sedative, phenobarbital; the anticonvulsants, phenytoin and carbamazepine; and the antibiotic, rifampin.

Polychlorinated Biphenyls (PCBs). Depending on dose and duration, PCBs can disrupt the production and disposition of thyroid hormones at a variety of levels and thereby may potentially interact with iodine in impairing the thyroid gland. The major findings include (1) histological changes in the thyroid gland indicative of both stimulation of the gland (e.g., similar to that induced by TSH or a hypothyroid state) and disruption of the processing of follicular colloid needed for normal production and secretion thyroid hormone; (2) depression of serum T_4 and T_3 levels, which may effectively create a hypothyroid state (in some studies, low doses resulted in elevated serum T_4 levels while depressed levels occurred at higher PCB doses); (3) increased rates of elimination of T_4 and T_3 from serum; (4) increased activities of T_4 -UDP-glucuronyl transferase (UDP-GT) in liver, which is an important metabolic elimination pathway for T_4 and T_3 ; (5) decreased activity of iodothyronine sulfotransferases in the liver, which are also important in the metabolic elimination of iodothyronines; (6) decreased activity of iodothyronine deiodinases, including brain Type-2 deiodinase, which provide the major pathways for the production of the active thyroid hormone, T_3 ; and (7) decreased binding of T_4 to transthyretin, an important transport protein for both T_4 and T_3 (ATSDR 2000).

Selenium. Selenium is essential for the activity of the glutathione peroxidases and iodothyronine deiodinases. In humans, concurrent selenium and iodine deficiency have been associated with goiter and cretinism, a developmental impairment related to prenatal hypothyroidism (Goyens et al. 1987; Vanderpas et al. 1990). Supplementation of individuals deficient in both iodine and selenium with selenium produces a further decrease in thyroid function, but if selenium supplementation is preceded by normalization of iodine levels, normal thyroid function is restored (Contempré et al. 1991, 1992). Selenium intake has been reported to affect thyroid hormone levels in humans; these effects include decreases in serum T_3 and T_4 levels and increases in serum TSH levels, suggesting suppression of thyroid hormone production (Brätter and Negretti De Brätter 1996; Duffield et al. 1999; Hagmar et al. 1998; Hawkes and Keim 1995). In experimental animals, selenium deficiency results in decreased metabolic clearance of iodothyronines and decreased extrathyroidal production of T_3 , as a result of decreased iodothyronine deiodinase activity, which can be restored to normal by selenium repletion (Arthur and Beckett 1994; Behne and Kyriakopoulos 1993). Selenium deficiency also results in decreases in thyroid iodine concentrations. The latter effect is thought to involve direct and indirect effects on thyroid hormone production and secretion. The direct effect is thought to result from decreased activity of glutathione peroxidase in the thyroid and increased availability of hydrogen peroxide for utilization in the production of iodothyronines in the thyroid, which can then be exported from the gland. The indirect effect may involve increased release of TSH from the pituitary gland in response to a decrease in plasma concentration of T_3 , resulting from inhibition of deiodination of T_4 .

3. HEALTH EFFECTS

Amiodarone. The more serious side effects of the use of the antiarrhythmia drug, amiodarone, are effects on the thyroid, including hypothyroidism, hyperthyroidism and thyroiditis (Meier and Burger 1996). Although the exact mechanisms for these effects are not completely understood, amiodarone contains a large quantity of iodine and has been shown to inhibit the deiodination of iodothyronines; in particular, the production of T₃ from T₄, most likely as a result of inhibition of Type 1 deiodinase (Table 3-7). A metabolite of amiodarone, desethylamiodarone, has been shown to inhibit binding of T₃ to thyroid hormone receptors in a variety of tissues (Green 1996). As a thyroid receptor antagonist, amiodarone (or its metabolite) also stimulates the release of TSH from the pituitary gland.

Lithium. Hypothyroidism and goiter have been associated with chronic therapy with lithium carbonate for management of bipolar disease (Green 1996; Spaulding et al. 1972). The mechanism for these effects is not understood, although it has been suggested that lithium may inhibit the coupling reaction in the synthesis of iodothyronines and may inhibit thyroid hormone secretion.

Propranolol. Propranolol is a drug used in the treatment of hypertension, angina, and other cardiovascular disorders as well as for the symptomatic treatment of thyrotoxicosis. Although the basis for its use in treatment of thyrotoxicosis is to counteract the cardiovascular symptoms of the disorder, the drug is also an inhibitor of iodothyronine deiodination (Meier and Burger 1996). The effect is unrelated to its activity as a β -adrenergic receptor antagonist, as both the L- and D-isomer (devoid of β -receptor antagonist activity) inhibit the deiodination of T₄. The mechanism for this action is not understood.

Dexamethasone. Although the corticosteroids exert multiple effects on the physiological regulation of thyroid hormone release (e.g., decreased TSH release from the pituitary), these agents also have appreciable activity as inhibitors of iodothyronine deiodinase and can decrease the metabolic clearance of iodothyronines (Meier and Burger 1996).

Iodinated Drugs. A variety of iodine-containing drugs have been shown to inhibit iodothyronine deiodination and thereby decrease the metabolic clearance of iodothyronines. These include the antiarrhythmic agent, amiodarone (previously discussed), and several radiographic contrast agents used for cholecystography such as iopanoic acid, sodium ipodate, and tyropanoate (Meier and Burger 1996).

3.10 POPULATIONS THAT ARE UNUSUALLY SUSCEPTIBLE

A susceptible population will exhibit a different or enhanced response to iodine than will most persons exposed to the same level of iodine in the environment. Reasons may include genetic makeup, age, health and nutritional status, and exposure to other toxic substances (e.g., cigarette smoke). These parameters result in reduced detoxification or excretion of iodine, or compromised function of organs affected by

3. HEALTH EFFECTS

iodine. Populations who are at greater risk due to their unusually high exposure to iodine are discussed in Section 6.7, Populations With Potentially High Exposures.

People who consume diets deficient in iodine may be more vulnerable to the toxic effects of exposure to radioiodine. At very low intakes, representing iodine deficiency (e.g., 20 µg/day), uptake of iodide into the thyroid gland is increased (Delange and Ermans 1996). This response is mediated by TSH, which stimulates iodide transport and iodothyronine production in the thyroid gland (see Section 3.5.1). If exposure to radioiodine was to occur in an individual who is iodine-deficient, a larger fraction of the absorbed radioiodine may be taken up by the thyroid gland and a larger radiation dose to the thyroid gland may be received. Iodine deficiency has been suggested to be a possible contributing factor to the increase in thyroid cancer incidence observed in Belarus after the Chernobyl reactor accident (Gembicki et al. 1997).

People who have multinodular goiter or thyroid gland adenomas can have foci of thyroid gland tissues that produce and secrete thyroid hormone autonomously from control of the gland by TSH. The mechanisms for thyroid tissue autonomy appear to involve clonal expansion of follicle cells that have a modified TSH receptor or receptor coupling mechanism (Corvilain et al. 2000). Autonomous nodules can give rise to hyperthyroidism (e.g., toxic nodular goiter, toxic adenoma). Iodine deficiency and goiter appear to be risk factors in the development of autonomous nodules (Aghini-Lombardi et al. 1999). People who have the autonomous nodules appear to be more vulnerable to iodide-induced hyperthyroidism (Braverman and Roti 1996; Ermans and Camus 1972). This may, in part, explain the increased incidence of hyperthyroidism that sometimes accompanies the introduction of iodide supplements into the diet of iodine-deficient populations (Connolly 1971b; Corvilain et al. 1998; Delange et al. 1999). In experimental studies, supplemental doses of 75–150 µg I/day for 1–2 weeks have induced hyperthyroidism in euthyroid patients who had autonomous thyroid adenoma (Livadas et al. 1977). Patients with certain types of thyroid autoimmunity may be more susceptible to developing hyperthyroidism when exposed to excess iodine (Braverman and Roti 1996; Braverman et al. 1971a).

Populations with diets that are deficient in selenium may be more susceptible to iodine toxicity. Selenium is a cofactor in the iodothyronine deiodinases that are important for the synthesis of the thyroid hormone, T₃, in extrathyroidal tissues. Iodine deficiency, in conjunction with selenium deficiency, has been associated with goiter and cretinism, a developmental impairment related to prenatal hypothyroidism (Goyens et al. 1987; Vanderpas et al. 1990). In this state, in which the thyroid gland is responding to a deficiency in T₃ production by increasing iodide transport and iodination activity in the thyroid gland, infants and children (as well as adults) may experience a higher thyroid uptake of absorbed iodine and possibly a higher radiation dose to the thyroid when exposed to radioiodine.

3. HEALTH EFFECTS

3.11 METHODS FOR REDUCING TOXIC EFFECTS

This section will describe clinical practice and research concerning methods for reducing toxic effects of exposure to iodine. However, because some of the treatments discussed may be experimental and unproven, this section should not be used as a guide for treatment of exposures to iodine. When specific exposures have occurred, poison control centers and medical toxicologists should be consulted for medical advice. The following text provides specific information about treatment following exposures to iodine:

Braverman LE, Utiger RD. 2000. Werner and Ingbar's the thyroid: A fundamental and clinical text. Philadelphia, PA: Lippincott-Raven.

Treatment of toxicity from exposure to excess iodine is directed at lowering exposure and, if clinical hypothyroidism or hyperthyroidism persists, correcting the thyroid dysfunction. Treatment of clinical hypothyroidism includes the administration of thyroid hormone. Treatment of hyperthyroidism involves administering thyroid hormone synthesis inhibitors.

Treatment of toxicity from exposure to radioiodine is also directed at lowering thyroid gland uptakes of absorbed iodine, for example, by administration of potassium iodide. If the exposure produces persistent hypothyroidism or hyperthyroidism, the treatment strategies for the clinical abnormalities are the same as those for exposure for nonradioactive iodine.

3.11.1 Reducing Peak Absorption Following Exposure

No information was located on methods to reduce peak absorption following exposure. Mitigation of toxic effects following exposure to radioiodine is directed at reducing the uptake of absorbed iodine in the thyroid gland (see Section 3.11.2).

3.11.2 Reducing Body Burden

Approximately 90% of the iodine in the human body is contained in the thyroid gland. The thyroid gland is also the major toxicity target of radioiodine. Therefore, methods for reducing the uptake and accumulation of radioiodine in the thyroid gland can reduce the radioiodine body burden, the absorbed radiation dose to the thyroid gland and body, and the toxic effects of exposure to radioiodine. Iodine uptake into the thyroid gland is highly sensitive to the iodide intake. At very high intakes of iodine, representing an intake excess (e.g., >1 mg/day), iodine uptake into the thyroid gland decreases, primarily as a result of decreased iodothyronine synthesis (Wolff-Chaikoff effect) and iodide transport into the gland (Nagataki and Yokoyama 1996; Saller et al. 1998). A single oral dose of 30 mg iodide (as sodium iodide) decreases the 24-hour thyroid uptake of radioiodine by approximately 90% in healthy adults (Ramsden et

3. HEALTH EFFECTS

al. 1967; Sternthal et al. 1980). The inhibition of uptake was sustained with repeated oral doses of sodium iodide for 12 days, with complete recovery to control (presodium iodide) uptake levels within 6 weeks after the last sodium iodide dose (Sternthal et al. 1980), or within 8 days after a single dose (Ramsden et al. 1967). Repeated oral doses of 1.5–2.0 mg iodide/m³ of surface area produced an 80% decrease in thyroid uptake of radioiodine in children (Saxena et al. 1962). Inhibition of radioiodine uptake by the thyroid gland that occurs when large doses of iodide are administered results in more rapid urinary excretion of radioiodine and decreased iodine body burden (Ramsden et al. 1967). The administration of iodide as prophylaxis for reducing thyroid uptake of radioiodine after accidental releases of radioiodine has been recommended by the FDA and NCRP (FDA 1978; NCRP 1977).

3.11.3 Interfering with the Mechanism of Action for Toxic Effects

The mechanisms of action of excess iodine in producing goiter, hypothyroidism, hyperthyroidism, or thyroiditis involve direct interactions between iodide and physiological elements involved in thyroid hormone synthesis and release, and iodine transport. Therefore, the principal strategy for reducing toxic effects is to decrease iodine intake or uptake into the thyroid gland (see Section 3.11.2). Numerous cases of reversal of iodine-induced hypothyroidism or hyperthyroidism after reduction of iodide intake have been reported and are described in this profile (see Section 3.2.2.2, Endocrine Effects). The principal clinical strategy for managing permanent hypothyroidism is the administration of T₄ (Brent and Larsen 2000). The principal clinical strategy for managing permanent hyperthyroidism is the administration of agents that inhibit iodination of thyroglobulin, such as propylthiouracil or methimazole, or that inhibit thyroid uptake of iodine, such as perchlorate or destruction of the thyroid gland with radiation. The latter is usually accomplished by administering a cytotoxic dose of ¹³¹I. β-Adrenergic antagonists are also used to manage some of the symptoms of thyrotoxicosis (Cooper 2000).

The sulfhydryl compound, amifostine, has been found to reduce the toxic effects of high exposures to ¹³¹I in patients who undergo ablative therapy with ¹³¹I for thyroid cancers (Bohuslavizki et al. 1996, 1998a, 1998b, 1999). The mechanism for the protective effect appears to be accumulation of amifostine in the salivary gland and scavenging of free radicals formed as a result of interactions of ionizing radiation from ¹³¹I with tissues.

3.12 ADEQUACY OF THE DATABASE

Section 104(i)(5) of CERCLA, as amended, directs the Administrator of ATSDR (in consultation with the Administrator of EPA and agencies and programs of the Public Health Service) to assess whether adequate information on the health effects of iodine is available. Where adequate information is not available, ATSDR, in conjunction with the National Toxicology Program (NTP), is required to assure the initiation

3. HEALTH EFFECTS

of a program of research designed to determine the health effects (and techniques for developing methods to determine such health effects) of iodine.

The following categories of possible data needs have been identified by a joint team of scientists from ATSDR, NTP, and EPA. They are defined as substance-specific informational needs that if met would reduce the uncertainties of human health assessment. This definition should not be interpreted to mean that all data needs discussed in this section must be filled. In the future, the identified data needs will be evaluated and prioritized, and a substance-specific research agenda will be proposed.

3.12.1 Existing Information on Health Effects of Iodine

The existing data on health effects of inhalation, oral, and dermal exposure of humans and animals to iodine are summarized in Figures 3-14 and 3-15. The purpose of this figure is to illustrate the existing information concerning the health effects of iodine. Each dot in the figure indicates that one or more studies provide information associated with that particular effect. The dot does not necessarily imply anything about the quality of the study or studies, nor should missing information in this figure be interpreted as a “data need”. A data need, as defined in ATSDR’s *Decision Guide for Identifying Substance-Specific Data Needs Related to Toxicological Profiles* (ATSDR 1989), is substance-specific information necessary to conduct comprehensive public health assessments. Generally, ATSDR defines a data gap more broadly as any substance-specific information missing from the scientific literature.

3.12.2 Identification of Data Needs

Acute-Duration Exposure. The primary effect of acute exposures to excess iodine in humans is hypothyroidism. This effect has been studied extensively in experimental studies of humans and is also well documented in the clinical case literature. Reported NOAELs for iodine-induced hypothyroidism in humans vary widely for reasons that are not completely understood. Acute exposures to excess iodine produce allergic reactions in people. The mechanisms for sensitivity and the reactions are not completely understood.

The effects of acute exposures to radioiodine (primarily ¹³¹I) have been extensively studied in humans. An enormous amount of epidemiological and case literature derives from the clinical use of ¹³¹I in diagnostic procedures and in treatment of thyroid gland enlargement and thyrotoxicosis. Epidemiology studies have also examined health effects resulting from accidental environmental exposures due to nuclear bomb detonations (e.g., Marshall Islands) and releases from nuclear power plants (e.g., Chernobyl). These studies collectively and convincingly identify the thyroid gland as the primary target of radioiodine. Other

3. HEALTH EFFECTS

Figure 3-14. Existing Information on Health Effects of Stable Iodine

	Systemic									
	Death	Acute	Intermediate	Chronic	Immunologic/Lymphoretic	Neurologic	Reproductive	Developmental	Genotoxic	Cancer
Inhalation										
Oral	•	•	•	•	•	•		•	•	•
Dermal		•	•	•	•			•		

Human

	Systemic									
	Death	Acute	Intermediate	Chronic	Immunologic/Lymphoretic	Neurologic	Reproductive	Developmental	Genotoxic	Cancer
Inhalation										
Oral		•	•	•	•				•	
Dermal										

Animal

- Existing Studies

3. HEALTH EFFECTS

Figure 3-15. Existing Information on Health Effects of Radioactive Iodine

	Systemic									
	Death	Acute	Intermediate	Chronic	Immunologic/Lymphoretic	Neurologic	Reproductive	Developmental	Genotoxic	Cancer
Inhalation										
Oral		•		•	•	•	•	•	•	•
Dermal										
External										

Human

	Systemic									
	Death	Acute	Intermediate	Chronic	Immunologic/Lymphoretic	Neurologic	Reproductive	Developmental	Genotoxic	Cancer
Inhalation										
Oral		•							•	•
Dermal										
External										

Animal

- Existing Studies

3. HEALTH EFFECTS

tissues that are either near the thyroid gland, such as the parathyroid gland, or that accumulate iodine, such as the salivary gland, also are affected by exposures to ^{131}I ; however, these effects occur at absorbed radiation doses that are clearly cytotoxic to the thyroid gland. Breast tissue expresses NIS and appears capable of accumulating ^{131}I and transferring it to mammary milk; therefore, it is a potential target of ^{131}I . However, epidemiology studies reported to date have not found a significant risk of breast cancer even after cytotoxic exposures to ^{131}I .

Intermediate-Duration Exposure. The primary effect of intermediate-duration exposures to excess iodine in humans is hypothyroidism. This effect has been studied extensively in humans and is well documented in the clinical case literature. Reported LOAELs for iodine-induced hypothyroidism in euthyroid humans, without goiter, fall within a reasonably narrow range, and are higher than those for people who are iodine deficient, suggesting a higher sensitivity in these subjects. The mechanisms for this are not completely understood. Intermediate-duration exposure has also been shown to induce hyperthyroidism in people who have nontoxic goiter. Here again, the mechanisms are not completely understood, although clonal expansion of autonomous follicle cells and autoimmunity are suspected contributors. Intermediate-duration exposures to excess iodine produce allergic reactions in people. The mechanisms for sensitivity and the reactions are not completely understood.

Chronic-Duration Exposure and Cancer. Epidemiological studies and clinical case literature identify the thyroid gland as the principal target of chronic exposure to excess iodine. Goiter, hypothyroidism, hyperthyroidism, and/or thyroid autoimmunity are the main outcomes of chronic exposure to excess iodine. Which effect occurs appears to be related to the pre-existing iodine intake (e.g., deficient or replete) and the presence or absence of possibly pre-existing autoimmunity and/or thyroid gland enlargement (or nodularity).

Genotoxicity. Stable iodine has been tested for genotoxicity in a variety of eukaryotic cell systems and has been found to be without mutagenic activity. The genotoxicity of radioactive iodine (^{131}I) has been extensively studied in clinical studies of patients who received ^{131}I for therapy of thyroid cancer and thyrotoxicosis and in people who were exposed to radioiodine from nuclear power plant accidents (e.g., Chernobyl).

Reproductive Toxicity. Several studies of reproductive effects of exposures to ^{131}I have been reported. These studies indicate that relatively high exposures to radioiodine (i.e., that are cytotoxic to the thyroid gland) can produce impairment of testicular function. The mechanism for this is not understood, but the observation of these effects suggests a possible exposure of the testes to ^{131}I . The testis is not presently known to express NIS; however, studies of the uptake of radioiodine in testes were not located.

3. HEALTH EFFECTS

Developmental Toxicity. Developmental toxicity of iodine and radioiodine related to effects on the fetal/neonatal thyroid gland has been well documented in the clinical case literature. The primary effect is congenital hypothyroidism and associated sequelae.

Immunotoxicity. The epidemiological and clinical case literature has identified thyroid autoimmunity and allergic reactions as the primary immunologic effects of exposure to excess iodine. Thyroid autoimmunity is an extremely important mechanism of thyroid gland disease. The mechanisms by which iodine induces thyroid autoimmunity are not completely understood. The production of antibodies to highly iodinated thyroglobulin has been proposed as a possible contributor.

Neurotoxicity. The primary target of iodine toxicity is the thyroid gland. A large amount of clinical literature exists on the neurological sequelae of thyroid gland disorders.

Epidemiological and Human Dosimetry Studies. The epidemiological literature on iodine- and radioiodine-related health effects is very substantial and provides information on exposures associated with the primary effect, thyroid gland dysfunction. There remain certain complications in the interpretation of the major epidemiology studies of environmental exposures to iodine and radioiodine. These relate to the magnitude of the contribution of iodine deficiency and autoimmunity in the observed thyroid gland outcomes (e.g., hypothyroidism, hyperthyroidism, thyroid gland nodularity, and cancers).

Studies of human dosimetry of ^{131}I are extensive, in large part, because of the extensive use of ^{131}I in diagnostic and treatment procedures that require highly certain estimates of the radiation dose delivered to the thyroid gland. The clinical information has been incorporated into reconstructions of thyroid doses experienced by the general public.

Biomarkers of Exposure and Effect.

Exposure. The use of urinary iodide for assessing steady state iodine intakes is well substantiated in the clinical and epidemiological literature and is supported by toxicokinetics studies in humans. Similarly, the use of external scintillation spectrometry to estimate radioiodine doses to the thyroid gland also has a substantial clinical history.

Effect. The clinical literature on thyroid gland disorders extensively documents the major biomarkers of thyroid gland dysfunction that are relevant to iodine toxicity.

3. HEALTH EFFECTS

Absorption, Distribution, Metabolism, and Excretion. The toxicokinetics of iodine in humans has been substantially explored and characterized in experimental studies and clinical cases. Radioiodine toxicity is most likely in tissues that can transport and accumulate iodide. Studies of the expression of NIS and factors that alter expression of NIS can further advance our understanding of which tissues are at risk and what factors, including genetic factors, might affect sensitivity to radioiodine in humans.

Comparative Toxicokinetics. The extensive information on the toxicokinetics of iodine in humans makes extrapolations from animals less important in assessing the health effects of iodine in humans. Studies of interindividual variability in humans are valuable for identifying sensitive subpopulations.

Methods for Reducing Toxic Effects. The principal method for preventing the toxic effects of radioiodine is dosing with stable iodine, which decreases the thyroid gland uptake of radioiodine and the absorbed radiation dose to the gland. The mechanistic basis and effectiveness of this approach is well established from experimental and clinical studies.

Children's Susceptibility. Higher susceptibility of the fetus and infants to iodine and radioiodine toxicity is substantiated by the epidemiological and clinical case literatures. The toxicokinetic basis for the susceptibility of infants and children to iodine exposure is understood. Uncertainties in assessing the potential health effect of iodine exposures are largely related to estimating exposures, in particular, the pathways by which environmental releases result in radioiodine uptake into the fetal or infant thyroid gland (see Section 6.8.1).

Child health data needs relating to exposure are discussed in 6.8.1 Identification of Data Needs: Exposures of Children.

3.12.3 Ongoing Studies

Ongoing studies pertaining to iodine have been identified and are shown in Table 3-9.

3. HEALTH EFFECTS

Table 3-9. Ongoing Studies on Health Effects of Radioactive Iodine

Investigator	Affiliation	Title	Sponsor
Baker, JR	University of Michigan at Ann Arbor	Characterization of thyroid autoantibodies and antigens	NCRR
Brent, GA	University of California, Los Angeles	Regulation of the sodium/iodine symporter in breast	NCI
Burek, CL	John Hopkins University	Immunotoxic effects of iodine	NIH—National Institute of Diabetes and Digestive and Kidney Diseases
Burek, CL	John Hopkins University	Nod h2h4 mice as a sentinel model for autoimmune thyroid	NIEHS
Carrasco, N	Yeshiva University	Characterization of the thyroid Na +/I-symporter	NIH—National Institute of Diabetes and Digestive and Kidney Diseases
Degroot, LJ	University of Chicago	Pathogenesis and therapy of autoimmune thyroid disease	NIH—National Institute of Diabetes and Digestive and Kidney Diseases
Kong, Y-CM	Wayne State University	T cell recognition—repertoire in autoimmune thyroiditis	NIH—National Institute of Diabetes and Digestive and Kidney Diseases
Naylor, EW	Neo Gen Screening, Inc.	Simplified population screening for adult hypothyroidism	NIH—National Institute of Diabetes and Digestive and Kidney Diseases
Refetoff, SS	University of Chicago	Regulation and mechanisms of hormone action	NIH—National Institute of Diabetes and Digestive and Kidney Diseases
Refetoff, SS	University of Chicago	Screening for inherited thyroid defects	NCRR
Sgouros, G	Sloan-Kettering Institute for Cancer	Modeling and dosimetry for radiolabeled antibody therapy	NCI
St Germain, DL	Dartmouth College	Regulation of thyroid hormone metabolism	NIH—National Institute of Diabetes and Digestive and Kidney Diseases
St Germain, DL	Dartmouth College	The role of the Type 3 deiodinase in development	NIH—National Institute of Diabetes and Digestive and Kidney Diseases
Weintraub, BD	University of Maryland, Baltimore Professional School	Structure/function relationships of human thyrotrophin	NIH—National Institute of Diabetes and Digestive and Kidney Diseases

Source: CRISP 2001; National Institutes of Health; Central Repository of Incidents, Solutions, and Problems

NCI = National Cancer Institute; NCRR = National Center for Research Resources; NIEHS = National Institute of Environmental Health Sciences; NIH = National Institute of Health/National Institute of General Medical Sciences

4. CHEMICAL, PHYSICAL, AND RADIOLOGICAL INFORMATION

4.1 CHEMICAL IDENTITY

Iodine is a nonmetallic element belonging to the halogen family in Group VIIA of the periodic table. Iodine is found in nature as iodide (i.e., I⁻) in brines or in molecular compounds with other elements (e.g., iodate or IO₃⁻). The chemical information for elemental iodine and some of its compounds is listed in Table 4-1. Radioactive isotopes of iodine (e.g., see Section 4.2) are an additional cause of concern with regard to human health (see Chapter 3).

4.2 PHYSICAL, CHEMICAL, AND RADIOLOGICAL PROPERTIES

The physical properties of iodine and selected iodine compounds are listed in Table 4-2. The percent occurrence of iodine isotopes and radiological properties of iodine isotopes is listed in Table 4-3.

Iodine can exist in several oxidation states: -1, 0, +1, +3, +5, and +7. Under normal environmental conditions, the -1, 0, and +5 oxidation states are the most important. There are 36 isotopes of iodine having masses between 108 and 143 (Chu et al. 1999); 14 of these yield significant radiation. The only naturally-occurring isotopes of iodine are ¹²⁷I and ¹²⁹I, which are stable and radioactive, respectively. Isotopes of mass less than 127 are produced in particle accelerators, while those >127 are formed in neutron generators such as nuclear reactors and atomic bombs. A total of 72% of uranium fissions and 75% of plutonium fissions leads directly or by beta decay of precursors, to iodine isotopes. For example, 2.89% of ²³⁵U and 3.86% of ²³⁹Pu fission atoms lead to the formation of a series of isobar 131 isotopes, including ¹³¹In, ¹³¹Sn, ¹³¹Sb, ¹³¹Te, ¹³¹I, and ¹³¹Xe. Each isotope can be formed as an initial fission product and, once formed, each isotope decays by beta-ray emission to the right on the sequence, through ¹³¹I, and ending with stable ¹³¹Xe. The process can be displayed as:

The same process occurs for ¹²⁹I ($t_{1/2}=1.6 \times 10^7$ years) and includes mass 129 isobars beginning with ¹²⁹Cd and ending with ¹²⁹Xe. Iodine isotopes above ¹²⁷I decay by emitting beta and gamma radiation, whose combined energies are unique to each iodine isotope. ¹³¹I, for example, decays by beta particle emission, and 0.96 MeV of energy is shared between the beta particle and the gamma ray. At least seven possible beta/gamma combinations occur. In 90.4% of the decays, a 0.61 MeV beta particle is emitted. The remaining excess energy is emitted as either a 0.364 MeV gamma ray for 85.3% of the time, or a pair of 0.284 and 0.080 MeV gamma rays for the other 5.1% of the time. The following is the decay scheme for ¹³¹I (Cember 1996):

Table 4-1. Chemical Identity of Iodine and Iodine Compounds

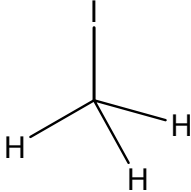
Property	Iodine	Hydrogen iodide	Sodium iodide	Potassium iodide	Methyl iodide	Cesium iodide
Chemical formula	I ₂	HI	INa	IK	CH ₃ I	CsI
Chemical structure	I—I	H—I	Na ⁺ I ⁻	K ⁺ I ⁻		Cs ⁺ I ⁻
Synonyms	Actomar; diiodine; eranol; iodine-127; molecular iodine	Hydroiodic acid	Sodium monoiodide; sodium iodine	Hydroiodic acid, potassium salt; PIMA; SSK; iodide of potash	Monoiodomethane; iodomethane	No data
Trade names	None	None	None	None	Halon 10001	No data
Identification numbers						
CAS registry	7553-56-2	10034-85-2	7681-82-5	7681-11-0	74-88-4	7789-17-5
NIOSH RTECS	NN1575000	MW3760000	WB6475000	TT2975000	PA9450000	No data
EPA hazardous waste	None	None	None	None	U138	None
OHM/TADS	None	None	None	None	None	None
DOT/UN/NA/IMO shipping	UN 1759; UN 1760	UN 2197; UN 1787 Corrosive material/IMO 8.0; IMO 2.0	None	None	UN 2644 Poison/IMO 6.1	None
HSDB	34	2155	750	5040	1336	None
NCI	42355	None	None	77362	9366	None
STCC	None	None	None	None	None	None

DRAFT FOR PUBLIC COMMENT

IODINE

4. CHEMICAL, PHYSICAL, AND RADIOLOGICAL INFORMATION

Table 4-1. Chemical Identity of Iodine and Iodine Compounds (continued)

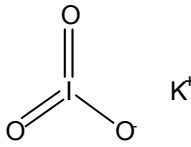
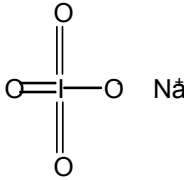
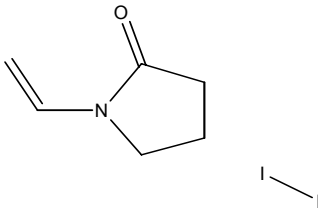
Property	Potassium iodate	Sodium periodate	Calcium iodide	Copper (I) iodide	Povidone iodine
Chemical formula	IKO_3	INaO_4	CaI_2	CuI	$\text{C}_6\text{H}_9\text{I}_2\text{NO}$
Chemical structure			$\text{I}^- \quad \text{Ca}^{+2} \text{I}^+$	$\text{Cu}^+ \quad \text{I}^-$	
Synonyms	Iodic acid, potassium salt	Sodium metaperiodate	Calcium diiodide; calcium iodide hydrate	Copper monoiodide; natural marshite; cuprous iodide	Poly(1-(2-oxo-1-pyrrolidinyl)-ethylene)iodine complex; betadine; efodine; Iodopoly(vinyl pyrrolidinone); isobetadyne; isodine; poly(vinylpyrrolidinone) iodide; ultradine
Trade names	None	None	None	None	None
Identification numbers					
CAS registry	7758-05-6	7790-28-5	10102-68-8	7681-65-4	25655-41-8
NIOSH RTECS	NN1350000	None	None	None	TR1579600
EPA hazardous waste	None	None	None	None	None
OHM/TADS	None	None	None	None	None
DOT/UN/NA/IMO shipping		None	None	None	None
HSDB	1231	None	None	271	6831
NCI		None	None	None	26245
STCC	None	None	None	None	None

Source: HSDB 2001; Lide 2000

CAS = Chemical Abstracts Services; DOT/UN/NA/IMCO = Department of Transportation/United Nations/North America/International Maritime Dangerous Goods Code; EPA = Environmental Protection Agency; HSDB = Hazardous Substances Data Bank; NCI = National Cancer Institute; NIOSH = National Institute for Occupational Safety and Health; OHM/TADS = Oil and Hazardous Materials/Technical Assistance Data System; RTECS = Registry of Toxic Effects of Chemical Substances; STCC = Standard Transportation Commercial Code

4. CHEMICAL, PHYSICAL, AND RADIOLOGICAL INFORMATION

Table 4-2. Physical and Chemical Properties of Iodine and Iodine Compounds^a

Property	Iodine	Hydrogen iodide	Sodium iodide	Potassium iodide
Molecular weight, g/mole	253.809 ^a	127.91 ^a	149.89 ^a	166.02 ^a
Color	Bluish-black ^a	Colorless ^a	White	Colorless or white ^a
Physical state	Solid; scales or plates ^a	Gas ^a	Solid; crystals or granules	Solid; crystals, granules, or powder ^a
Melting point	113.60 EC ^a	-50.8 EC ^a	651 EC ^a	680 EC ^a
Boiling point	185.24 EC ^a	-35.1 EC ^a	1,304 EC ^d	1,323 EC ^d
Density, g/cm ³ (25 EC)	4.93 ^a	5.23 ^a	3.67 ^a	3.12 ^a
Odor	Characteristic ^a	No data	Odorless ^a	No data
Odor threshold:				
Water	No data	No data	No data	No data
Air	No data	No data	No data	No data
Solubility (25 EC):				
Water	330 mg/L ^a	2,340 g/L (10 EC) ^a	2,000 g/L ^a	1,429 g/L ^a
Organic solvents(s)	141 g/kg benzene ^a	Soluble ^a	500 g/L alcohol ^a	13 g/L acetone ^a
Partition coefficients:				
Log K _{ow}	2.49 ^b	No data	No data	No data
Log K _{oc}	No data	No data	No data	No data
Vapor pressure (25 EC)	0.305 mm Hg ^a	5,940 mm Hg ^c	1 mm Hg (767 EC) ^c	No data
Henry's law constant	No data	No data	No data	No data
Autoignition temperature	No data	No data	No data	No data
Flashpoint	No data	No data	No data	No data
Flammability limits	No data	Non-flammable	No data	No data
Explosive limits	No data	No data	No data	No data

4. CHEMICAL, PHYSICAL, AND RADIOLOGICAL INFORMATION

**Table 4-2. Physical and Chemical Properties of Iodine and Iodine Compounds^a
(continued)**

Property	Methyl iodide	Cesium iodide	Potassium iodate	Sodium periodate
Molecular weight, g/mole	141.94 ^a	259.81 ^a	214.02 ^a	213.892 ^d
Color	Colorless ^a	Colorless ^d	White ^a	White ^d
Physical state	Liquid ^a	Solid; crystals, or powder ^a	Solid, crystals ^a	Solid; crystals ^d
Melting point	-66.5 EC ^a	621 EC ^a	560 EC ^a	Decomposes ~300 EC
Boiling point	42.5 EC ^a	ca. 1,280 EC ^a	No data	No data
Density, g/cm ³ (25 EC)	2.28 (20 EC) ^a	4.5 ^a	3.98 ^c	3.86 ^d
Odor	Pungent, ether-like ^c	No data	No data	No data
Odor threshold:				
Water	No data	No data	No data	No data
Air	No data	No data	No data	No data
Solubility (25 EC):				
Water	13.9 g/L (20 EC) ^c	Miscible ^a	9.16 g/100 g ^c	Soluble ^d
Organic solvents(s)	Miscible ^a	Soluble in alcohol; insoluble in acetone ^a	No data	No data
Partition coefficients:				
Log K _{ow}	1.51 ^c	No data	No data	No data
Log K _{oc}	No data	No data	No data	No data
Vapor pressure (25 EC)	405 mm Hg	No data	No data	No data
Henry's law constant	0.00526 atm-cu m/mole	No data	No data	No data
Autoignition temperature	No data	No data	No data	No data
Flashpoint	No data	No data	No data	No data
Flammability limits	No data	No data	No data	No data
Explosive limits	No data	No data	No data	No data

4. CHEMICAL, PHYSICAL, AND RADIOLOGICAL INFORMATION

**Table 4-2. Physical and Chemical Properties of Iodine and Iodine Compounds
(continued)**

Property	Calcium iodide	Copper (I) iodide	Povidone iodine
Molecular weight, g/mole	293.89 ^a	190.45 ^a	364.95 ^c
Color	Yellow ^a	Red-brown ^a	Yellow-brown ^c
Physical state	Solid; lumps or powder ^a	Solid; powder or crystals ^a	Solid; powder ^c
Melting point	740 EC	588–606 EC ^a	300 EC ^e
Boiling point	1,100 EC	~1,290 EC ^a	No data
Density, g/cm ³ (25 EC)		5.63 ^a	
Odor	No data	No data	Slight characteristic ^c
Odor threshold:			
Water	No data	No data	No data
Air	No data	No data	No data
Solubility (25 EC)			
Water	Very soluble ^a	80 mg/L (18 EC) ^c	Soluble ^c
Organic solvents(s)	Very soluble in alcohol, acetone ^a	Insoluble ^a	Insoluble ^c
Partition coefficients:			
Log K _{ow}	No data	No data	No data
Log K _{oc}	No data	No data	No data
Vapor pressure	No data	No data	No data
Henry's law constant	No data	No data	No data
Autoignition temperature	No data	No data	No data
Flashpoint	No data	No data	No data
Flammability limits	No data	No data	No data
Explosive limits	No data	No data	No data

Source: Chemfinder 2001, unless otherwise specified.

^aBudavari et al. 1998

^bHansch and Leo 1995

^cHSDB 2000

^dLide 2000

4. CHEMICAL, PHYSICAL, AND RADIOLOGICAL INFORMATION

Table 4-3. Percent Natural Occurrence and Radioactive Properties of Isotopes of Iodine

Isotope	CAS registry number	Natural abundance (%)	Beta energies, MeV ^a (Intensity)	Gamma energies, keV ^a	Half-life	Activity, Ci/gram ^c
¹²³ I	15715-08-9	–	1.08 (97.0%)	158.97	13.3 hours	1.92x10 ⁶
¹²⁴ I	14158-30-6	–	EC ^b	602.7 722.8 1691.0	4.18 days	2.52x10 ⁵
¹²⁵ I	14158-31-7	–	EC ^b	35.5	59.4 days	1.76x10 ⁴
¹²⁶ I	14158-32-8	–	EC ^b	388.6 666.3 753.8	13.11 days	7.91x10 ⁴
¹²⁷ I	7553-56-2	<100	–	–	stable	–
¹²⁹ I	15046-84-1	0>	0.154	29.5 29.8 33.6	1.57x10 ⁷ years	1.77x10 ⁴
¹³¹ I	10043-66-0	–	0.334 (7.3%) 0.606 (89.9%)	284.3 364.5	8.02 days	1.24x10 ⁵
¹³² I	14683-16-0	–	0.74 (13.0%) 0.96 (8.2%) 1.18 (18.8%) 1.61 (12.6%) 2.14 (19.0%)	667.7 772.6 954.6	2.30 hours	1.03x10 ⁷
¹³³ I	14834-67-4	–	0.54 (87.0%) 0.88 (4.5%)	529.9 875.3	20.8 hours	1.13x10 ⁶
¹³⁴ I	14914-27-3	–	1.31 (30.4%) 1.59 (16.2%) 1.82 (11.0%) 2.44 (12.5%)	847.0 884.1	52.5 minutes	2.67x10 ⁷
¹³⁵ I	14834-68-5	–	679.7 (8.0%) 856.8 (8.8%) 969.9 (21.9%) 1,082.7 (8.0%) 1,387.6 (23.8%)	546.6 836.8 1,038.8 1,131.5	6.57 hours	3.53x10 ⁶

Source: Chu et al. 1999

^aNot all gamma and beta energies are included in summary; see Chu et al. (1999) for a complete listing^bEC = electron capture decay^cActivity = (N_A ln2)/(M_w t_{1/2})

4. CHEMICAL, PHYSICAL, AND RADIOLOGICAL INFORMATION

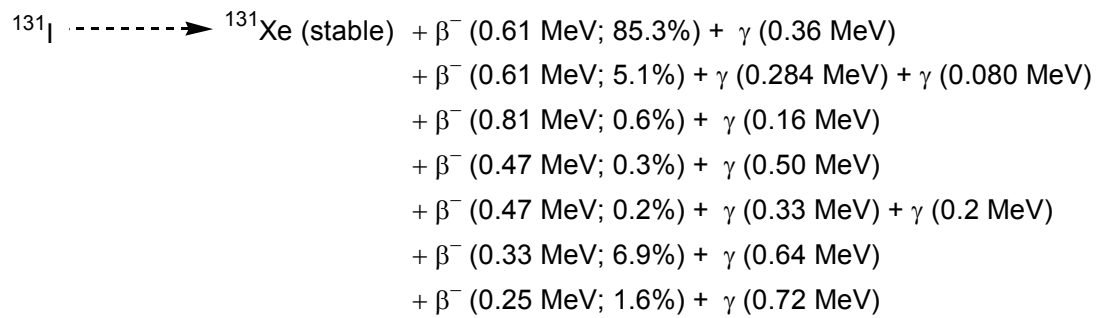

Isotopic masses of iodine <127 can be produced using a beam of high energy protons generated using a linear accelerator. Proton beams tuned at fixed energies up to 30 MeV produce isotopes, such as ${}^{123}\text{I}$, by interaction of the proton beam with a high atomic weight target.

5. PRODUCTION, IMPORT/EXPORT, USE, AND DISPOSAL

5.1 PRODUCTION

Iodine, a halogen, occurs in low concentrations in nature in the form of iodides mainly in sea water, although there are a number of major sources iodine including the underground waters from certain deep-well boring and mineral springs (i.e., brines) and natural deposits of sodium nitrate ore (i.e., caliche) found in the northern part of Chile. Only a few marine organisms contain iodine in relatively large quantities including seaweeds, sponges, and corals. The different production processes for recovering iodine are based on the raw materials used. About 65% of the iodine consumed in the world comes from brines processed in Japan, the United States, and the former Soviet Union. The primary production process for recovery of iodine from brines is the blow-out process. The blow-out process for brines can be divided into brine clean-up, iodide oxidation followed by air blowing and recovery, and iodine finishing. In 2000, iodine was recovered from brines by the blow-out process by three companies operating in Oklahoma, which accounted for 100% of the U.S. elemental iodine production. These three companies are IOCHEM Corporation (Dewey County, Oklahoma), North American Brine Chemicals (Dover, Oklahoma), and Woodward Iodine Corporation (Woodward County, Oklahoma). Production of iodine in the United States has remained steady ranging from 1,270 to 1,620 metric tons between the years 1996 and 1999 (Lauterbach et al. 1995; USGS 1998, 2001).

After World War II, the U.S. government began stockpiling iodine for defense applications. By 1968, the DOD had acquired 3,700 metric tons of iodine. In 1992, Congress determined that the stockpile was unnecessary, reduced the stockpile goal to zero, and authorized the sale of all excess material. As of September 30th, 2000, the uncommitted inventory of stockpile-grade iodine was 1,782 metric tons (USGS 1998, 2001).

The only naturally occurring isotopes of iodine are ^{127}I and ^{129}I , which are stable and radioactive, respectively. Other radioactive iodine isotopes (e.g., ^{131}I) do not occur in nature; they are the direct result of anthropogenic activity. As discussed in Chapter 4, ^{129}I and ^{131}I are produced by nuclear fission. Nearly all of the ^{129}I and ^{131}I generated in the United States is present in spent nuclear reactor fuel rods. These fuel rods are currently located at commercial reactor facilities or at Department of Energy (DOE) facilities across the United States. The cumulative yield of ^{129}I is about 1% of all fission products. Thus, ^{129}I represents only a very small fraction of the total fission product inventory in the nuclear fuel cycle. A limited amount of ^{123}I , ^{125}I , and ^{131}I will be produced for industrial, scientific, and medicinal applications by International Isotopes Inc. (Denton, Texas) using a linear accelerator (DOE 1996d; International Isotopes 2001; USGS 1998).

5. PRODUCTION, IMPORT/EXPORT, USE, AND DISPOSAL

5.2 IMPORT/EXPORT

In 1999, 62% of the apparent consumption of iodine in the United States (5,650 metric tons) was imported. Of the 5,430 metric tons of iodine imported in 1999, approximately 64% was imported from Chile, 27% from Japan, and 9% from Russia. Exports of iodine have decreased from 2,410, 2,760, and 2,790 metric tons in 1996, 1997, and 1998, respectively, to 1,130 metric tons in 1999 (USGS 1998, 2001).

5.3 USE

End uses for iodine in 1996 were estimated from a United States Geological Survey (USGS) canvass of consumers as follows (by percentage): sanitation (39%); pharmaceutical (24%); heat stabilizers (13%); catalyst (9%); animal feed (7%); and other (8%). Other smaller uses included inks and colorants, photographic chemicals, laboratory reagents, production of batteries, high-purity metals, motor fuels, and lubricants. Hydrogen iodide (i.e., HI) is used in the manufacture of hydroiodic acid and organic iodo compounds, and to remove iodine from iodo compounds. Potassium iodide (i.e., KI) is used in animal feeds, catalysts, photographic chemicals, for sanitation, and for treatment of poisoning with radioactive materials resulting from nuclear accidents. Sodium iodide (i.e., NaI) is used in photography and for the production of organic chemicals. Methyl iodide (i.e., CH₃I) is used as a methylation agent in organic synthesis, in microscopy, as an embedding material for examining diatoms, and in testing for pyridine. Potassium iodate (i.e., KIO₃) is used in salt iodization, an oxidizing agent in analytical chemistry, and as a maturing agent and dough conditioner (Lauterbach and Ober 1995; USGS 1998).

Radioactive iodine has been used successfully for the treatment of cancer of the thyroid. The radioactive isotope ¹²³I is considered the agent of choice for brain, thyroid, and renal imaging and uptake measurements. ¹²⁵I is used as a cancer therapeutic, and as a brain, blood, and metabolic function diagnostic. ¹³¹I is used as a brain, pulmonary, and thyroid diagnostic (Lauterbach 1995; USGS 1998).

5.4 DISPOSAL

Most nonradioactive iodine minerals, iodine compounds, and iodine-containing materials do not require special disposal or handling requirements. However, some chemical forms may be classified as hazardous materials if the compound is chemically reactive, flammable, or toxic. Care should be taken to read and understand all of the hazards, precautions, and safety procedures for each specific chemical form. In addition, all federal, state, and local laws and regulations should be investigated and subsequently followed with regard to disposal and handling of the specific chemical form of the iodine compound or material.

Radioactive iodine does require special disposal and handling requirements and is regulated by the Nuclear Regulatory Commission. Radioactive waste-containing radioactive iodine can be grouped into three

5. PRODUCTION, IMPORT/EXPORT, USE, AND DISPOSAL

categories: low-level waste (LLW); high-level waste (HLW) and spent nuclear fuel; and mixed waste. As defined by the Nuclear Waste Policy Act, high-level radioactive waste is “the highly radioactive material resulting from the reprocessing of spent nuclear fuel, including liquid waste produced directly in reprocessing and any solid material derived from such liquid waste that contains fission products in sufficient concentration.” However, most classifications of HLW also include spent nuclear fuel. Most HLW was generated from the production of plutonium. A small fraction is related to the recovery of enriched uranium from naval reactor fuel. This waste typically contains highly radioactive, short-lived high activity fission by-products as well as other long-lived isotopes, hazardous chemicals, and toxic heavy metals. Radioiodine contamination is only a small fraction of the activity of HLW. Liquid HLW is typically stored in large underground tanks of either stainless steel or carbon steel depending on whether they are acid or alkaline solutions. There are about 100 million gallons of high-level liquid waste stored in underground tanks in Washington, South Carolina, Idaho, and New York. These tanks contain a variety of radioactive liquids, solids, and sludges. Some of the liquid wastes have been solidified into glass, ceramic slag, salt cakes, and sludges (DOE 1996a; Murray 1994).

Spent nuclear fuels, such as fuel elements and irradiated targets used in nuclear reactors, are currently disposed of at the commercial nuclear power plants and DOE facilities where they were produced. Spent fuel is highly radioactive due to the large concentration of fission products and must be stored in special water-cooled pools that shield and cool the material. Most of the radioactive iodine remains trapped in the spent fuel rod matrix and is never released. Roughly all DOE spent fuel, about 3,000 metric tons, is stored at four sites: Hanford, Savannah River, Idaho National Engineering Laboratory, and West Valley, New York. Commercial reactors have generated more than 30,000 metric tons of spent fuel. The spent fuel from these facilities is stored at the more than 100 commercial nuclear reactor sites around the United States. Since spent commercial nuclear reactor fuel is placed in on-site storage while awaiting off-site disposal, the only isotope of iodine remaining in the fuel matrix when it leaves the generating facility will be ^{129}I . The establishment of an HLW and spent fuel repository for both DOE and commercial waste is currently under evaluation at Yucca Flats, Nevada. It is not projected to be in operation until after the year 2010 (DOE 1996b, 2001d; Eisenbud 1987; Murray 1994).

Mixed waste contains both radioactive and chemically hazardous materials such as toxic, corrosive, flammable, or explosive materials. The radioactive component may be either HLW or LLW. All liquid HLW is mixed waste, usually in the presence of organic solvents or heavy metals in addition to radioactive components. Disposal of mixed wastes is regulated by the EPA under the Resource Conservation and Recovery Act (RCRA) and by the National Regulatory Commission under the Atomic Energy Act. The EPA and National Regulatory Commission have developed special procedures on how to handle and dispose of this special category. The DOE operates an incinerator in Oak Ridge, Tennessee, which burns mixed hazardous radioactive wastes (DOE 1996a).

5. PRODUCTION, IMPORT/EXPORT, USE, AND DISPOSAL

Low-level waste is all radioactive waste that cannot be classified as HLW, spent fuel, or mixed waste. Low-level does not necessarily mean low radioactivity or low environmental hazards. However, the bulk of LLW has relatively little radioactivity and practically no transuranic elements. Thus, LLW usually does not require shielding from radioactivity or heat removal equipment. Most LLW is acceptable for near surface land disposal. LLW types that may be contaminated with ^{129}I include both wet and dry wastes. Examples of the physical form of LLW are spent ion exchange resins, filter sludges, filter cartridges, evaporator bottoms, compactible trash, noncompactible trash, irradiated components, ashes produced from the incineration of combustible material, contaminated detergents or solvents, organic liquids, and discarded contaminated equipment or tools. Of the LLW generated today, approximately 64% of the volume and 70% of the radioactivity are generated as a result of nuclear power plant activities or supporting fuel cycle operations. Other sources of LLW are industrial, academic, government, and medical. Radioiodine contamination accounts for only a small fraction of the activity of LLW. LLW typically is packaged in drums or boxes and buried in shallow pits or trenches. Approximately 3 million cubic meters of LLW generated in the United States have been disposed of this way. LLW from DOE sources is currently disposed of at several DOE facilities across the United States. Only three sites accept non-DOE LLW, Barnwell, South Carolina; Richland, Washington; and Envirocare of Utah, Inc. (Clive, Utah). Over half of the LLW in the eastern United States is disposed of at the Barnwell site. As required by the Federal LLRW (Low Level Radioactive Waste) Policy Act in 1980 and the 1985 amendments, states or interstate compacts are required to build facilities to contain LLW generated from sources within their boundaries. However, other than Barnwell, South Carolina; Richland, Washington; and Clive, Utah sites, no other facility in the United States is currently accepting LLW from non-DOE sources. Currently, many generators store LLW on-site until additional facilities can be constructed in the future (DOE 1996a; Eisenbud 1987; Envirocare 2001; Murray 1994).

Decay on-site is one method chosen in the medical community to handle their low level radioiodine waste. Contaminated clothing, food trays, linen, materials used to clean patients' rooms, furniture, and telephones are quarantined until levels of radioiodine are sufficiently low. A period of 10 half-lives may be adequate to reduce the radioactivity to safe levels to permit reuse of the materials without controls.

6. POTENTIAL FOR HUMAN EXPOSURE

6.1 OVERVIEW

Stable iodine has been identified in at least 8, iodine-129 (^{129}I) in at least 2, and iodine-131 (^{131}I) in at least 6 of the 1,585 hazardous waste sites that have been proposed for inclusion on the EPA National Priorities List (NPL) (HazDat 2001). However, the number of sites evaluated for iodine, ^{129}I , and ^{131}I is not known. The frequency of these sites can be seen in Figures 6-1, 6-2, and 6-3, respectively. All of these sites are located within the United States.

Iodine is a naturally occurring constituent of the earth's crust and is the least abundant of the halogen elements (Straub et al. 1966). The stable isotope iodine, ^{127}I , is ubiquitous throughout the earth's surface. The concentration of ^{127}I in the earth's crust is approximately 0.5 ppm; in the oceans, the concentration is 45–60 $\mu\text{g/L}$, and in the atmosphere, the concentration ranges from 10 to 20 ng/m^3 . Concentrations of iodine in the environment throughout the United States vary depending on the proximity to the seacoast and the soil type. The concentration of iodine in bedrock varies between 0.5 and 380 ppm, depending on whether the rock is igneous or sedimentary.

Iodine exists in many chemical forms (e.g., molecular iodine, iodide, iodate, periodate) and can undergo oxidation-reduction as well as microbial alkylation (mostly methyl iodide). Iodine has nine radioisotopes, of which ^{125}I , ^{129}I , and ^{131}I are commonly encountered in acute or chronic exposures to human populations, due either to the life-times of the radioisotope in the environment, their production, and/or their utilization in industry, medicine, and research.

^{129}I is the only naturally occurring iodine radioisotope. It is produced as a fission product of uranium and thorium in soils and oceans, and is also formed in reactions of xenon with high energy particles in the upper atmosphere and reactions of neutrons with ^{128}Te and ^{130}Te (Soldat 1976). ^{129}I has a half-life of 1.6×10^7 years and decays through β emission; ^{129}I has a mass/decay rate equivalency of 1 g ^{129}I =6.55 MBq (177 microcuries) (Robkin and Shleien 1995). $^{129}\text{I}/^{127}\text{I}$ ratios from natural production of ^{129}I should be 3×10^{-14} in the environment, but with the introduction of ^{129}I from nuclear weapons testing and nuclear energy activities, the ratio is now 10^{-8} (Ballad et al. 1978). The estimated global inventory of ^{129}I is approximately 9,600 Ci (5.43×10^7 g), of which 9,200 Ci (5.2×10^7 g) is associated with igneous activity (DOE 1994).

^{125}I and ^{131}I are produced in the fission of uranium and plutonium by neutron bombardment in reactors and/or heavy nuclei particles in accelerators. The half-life of ^{125}I is 60 days and decays through electron

Figure 6-1. Frequency of NPL Sites with Iodine Contamination



DRAFT FOR PUBLIC COMMENT

Figure 6-2. Frequency of NPL Sites with Iodine 129 Contamination



DRAFT FOR PUBLIC COMMENT

Figure 6-3. Frequency of NPL Sites with Iodine 131 Contamination



DRAFT FOR PUBLIC COMMENT

6. POTENTIAL FOR HUMAN EXPOSURE

capture (EC) emitting a 35.5 keV gamma-ray and K-shell x-rays (27.4 keV, 112%; 31.4 keV, 24%). The specific activity of ^{125}I is 67.7 TBq/g or 18,277 Ci/g. The half-life of ^{131}I is 8.02 days and decays through β emission; ^{131}I has a specific activity of 457 TBq/g or 123,429 Ci/g. Unlike ^{129}I , ^{125}I and ^{131}I do not have long residency times in the environment due to their short half-lives and, thus, do not pose risks associated with an accumulation in the environment. However, in acute exposures to ^{125}I and ^{131}I , there is the potential for significant radiation to the thyroid.

Releases of iodine into the environment occur from both natural sources and human activity. The natural sources include volatilization of iodine from the oceans, weathering of rock, and volcanic activity (Cohen 1985; Whitehead 1984). Sources of iodine from human activities include release of radioiodine from nuclear weapons testing and nuclear fuel reprocessing, waste stream effluent from municipal plants, and combustion of waste and fossil fuels (Likhtarev et al. 1993; Moran et al. 1999; NAS 1974; NCRP 1983; Stetar et al. 1993).

Iodine enters the atmosphere mainly through volatilization of methyl iodide and, to a lesser extent, molecular iodine from the ocean surface. ^{129}I is introduced naturally through the conversion of xenon-129 to ^{129}I through the interaction with high energy particles in the upper atmosphere. ^{131}I was released through weapons production/utilization, nuclear fuel reprocessing, and energy production (AEC 1974; Likhtarev et al. 1993; Marter 1993; Moran et al. 1999; NCRP 1983; Robkin and Sheien 1995). In the atmosphere, iodine undergoes extensive photochemical changes and can exist as gaseous inorganic, gaseous organic, or particulate forms. These forms have an average residency time in the atmosphere of 10, 18, and 14 days, respectively (Whitehead 1984).

The gaseous inorganic and particulate forms of iodine are precipitated from the atmosphere through wet (rain, sleet, and snow) and dry (gravitational settling and wind turbulence) deposition processes (Whitehead 1984). Alkyl iodides, such as methyl iodide, have a low susceptibility to both wet and dry deposition. The deposition of iodine will depend on particle size and concentration, wind turbulence, and the chemical form of iodine. If precipitation occurs over land, iodine will be deposited onto plant surfaces or soil surfaces, or into surface waters. The average retention time of iodine on plant surfaces is 7.5–14 days due to weathering (AEC 1974; Heinemann and Vogt 1980; Kirchner 1994). Retention of iodine in the soil is influenced by a number of factors, including soil pH, soil moistness, porosity of soil, and composition of organic and inorganic (e.g., aluminum and iron oxides) components (Sheppard et al. 1995; Whitehead 1984). Approximately 1% of iodine received through atmosphere-to-soil deposition is returned through volatilization of molecular iodine and methyl iodide; the remaining iodine is eventually returned to the oceans through surface water and groundwater (NRC 1979; Whitehead 1984). The average residency time of iodine in the soil at 0.3- and 1-meter depths has been suggested to be 80 and 800 years, with only 1–3% of deposited iodine migrating to the 1-meter depth (DOE 1986).

6. POTENTIAL FOR HUMAN EXPOSURE

Transport of iodine through surface water and groundwater is not greatly retarded by the soil, rock, and sediments over or through which these waters flow (NRC 1981). The concentration of iodine in river water ranges between 0.1 and 18 $\mu\text{g/L}$, which parallels the concentration of iodine in rainwater of 0.1–15 $\mu\text{g/L}$ (NRC 1979). In groundwater, the mean concentration is 1 $\mu\text{g/L}$ (Yuita 1994a). The concentration of iodine in river water often increases downstream of urban areas due to the discharge of waste streams from municipal treatment facilities. This is especially true for ^{131}I that enters sewage streams from patients undergoing radioiodine therapies (Tubiana 1982; UNSCEAR 2000). Slightly elevated concentrations of ^{129}I have been observed in surface water and groundwater near nuclear fuel reprocessing facilities (Beals and Hayes 1995; DOE 1994).

Iodine has been shown to bioaccumulate in many seawater and freshwater aquatic plants (Poston 1986). Freshwater plants (e.g., algae) contain 10⁻⁵% by weight of iodine, whereas marine plants (algae) contain 10⁻³% by weight (NCRP 1983). In freshwater fish, iodine concentrations in tissues range from 0.003 to 0.81 ppm, which gives concentration ratios (fish/water) of 0.9–810. In marine fish, the iodine concentrations range between 0.023 and 0.11 ppm, yielding concentration ratios of between 10 and 20 (Poston 1986). In terrestrial plants, iodine can be taken up through the roots, mainly as iodide and to a lesser extent, as iodate or iodine (Burte et al. 1991; Whitehead 1984). The average iodine concentration in terrestrial plants is 0.42 $\mu\text{g/g}$. The uptake is dependent on soil conditions and the use of fertilizers (Moiseyev et al. 1984). Distribution of iodine and iodide varies throughout the plant (Voigt et al. 1988). The uptake of iodine into terrestrial plants in combination with deposition of iodine onto the surfaces of plants plays an important role in the transfer of iodine through the soil-plant-cow-milk pathway. The efficiency through which iodine is transferred through this pathway is important in ascertaining the risk of radioiodine exposures in the general human population from continuous or accidental releases of ^{131}I and ^{129}I , especially in children (AEC 1974; Soldat 1976; Tubiana 1982; Voigt et al. 1989).

The iodine content of food has been studied extensively, with intakes of iodine typically ranging from 0.064 to 0.379 mg/day (FDA 1974; Pennington et al. 1984, 1986). The major sources of iodine intake from food in a typical U.S. diet are added salt and food additives, followed by meat and meat products, milk and milk products, and green/yellow vegetables (FDA 1974). Other foods that can provide a high amount of iodine in the diet include seaweed, marine shellfish, and marine fish.

It is estimated that the intake of iodine through inhalation is 4×10^{-5} g/year (NRC 1979). The average intake of iodine from drinking water, assuming an average iodine concentration of 3 $\mu\text{g/L}$, is estimated to be 1.5×10^{-3} g/year (NRC 1979). If the average intake of iodine from food is assumed to be the recommended dietary allowance (RDA) for iodine of 150 mg/day, then the yearly intake of iodine would be approximately 55 g. Thus, the largest source of iodine in the average U.S. diet comes from food intake. The intake of iodine through food consumption can be increased greatly in diets high in marine fish

6. POTENTIAL FOR HUMAN EXPOSURE

(- 800 µg/kg wet weight), shellfish (- 800 µg/kg), and seaweed-based products (0.8–4.5 g/kg dry weight) (FDA 1974).

Currently, the intake of ^{129}I and ^{131}I by the general population through inhalation, drinking water, and food intake does not pose any significant risk, due to the extremely low levels of ^{129}I and ^{131}I in the general environment. However, there are certain populations of individuals who are at risk to potential exposures to high levels of iodine or acute/chronic levels of radioiodine. Individuals undergoing specific diagnostic or therapeutic procedures or receiving certain types of medications can significantly increase whole-body and thyroid burdens of iodine and ^{131}I (FDA 1989b; Tubiana 1982). Family members, especially children, of patients undergoing ^{131}I therapies can experience exposure to both the radioisotope and the radiation emitted from ^{131}I (Barrington et al. 1999; Jacobson et al. 1978). Likewise, medical personnel working with, or in proximity to, ^{131}I can also have elevated whole-body and thyroid burdens of this radioisotope and are at risk to exposure to the photon radiation emitted from ^{131}I (Blum and Liuzzi 1967; Mountford and O'Doherty 1999; Tubiana 1982). Workers in nuclear power plants or nuclear fuel reprocessing facilities are at risk for potentially high acute exposures of ^{129}I and ^{131}I (Bhat et al. 1973; Raghavendran et al. 1978). Laboratory workers who are involved in the iodination of chemicals or biologics with $^{125}\text{I}/^{131}\text{I}$ or the use of these radioiodinated materials also show increased thyroid burdens of these radioisotopes (Bogdanove and Strash 1975; de Groot 1979; Dunn and Dunscombe 1981; Jönsson and Mattsson 1998; Kivinitty et al. 1984; Krzesniak et al. 1979; Kwok and Hilditch 1982; Pomroy 1979).

6.2 RELEASES TO THE ENVIRONMENT

Iodine, ^{129}I , and ^{131}I have been identified in 8, 2, and 6, respectively, of 1,585 current or former NPL hazardous waste sites within a variety of environmental media (air, leachate, and groundwater) collected at these sites (HazDat 2001).

Releases of iodine and its radioisotopes into the environment occur from natural sources and from human activity (Figures 6-4 and 6-5). The emphasis of the discussion of iodine release into the atmosphere will focus on atmospheric (air), water (marine and surface waters), and soils which are major compartments in the geochemical cycling of iodine (Figures 6-4 and 6-5). Throughout this chapter, the units used to express concentration or intake of iodine and its radioisotopes are the same units reported by the authors. In some cases, values are expressed in mass units, while in other cases, the values are expressed as activities (either in Bq or Ci). For ^{129}I , the mass/decay rate equivalencies is $1 \text{ g } ^{129}\text{I} = 6.55 \text{ MBq}$ (177 microcuries) (Robkin and Shleien 1995). For ^{131}I , the specific activity of this radioisotope is 457 TBq/g or 123,429 Ci/g. For ^{125}I , the specific activity is 67.7 TBq/g or 18,277 Ci/g.

6. POTENTIAL FOR HUMAN EXPOSURE

6.2.1 Air

Iodine, ^{129}I , and ^{131}I have been identified in 2, 1, and 6 air samples, respectively, collected from the 1,585 NPL hazardous waste sites where it was detected in some environmental media (HazDat 2001).

The introduction of iodine into the atmosphere is derived from both natural and human activities (Figures 6-4 and 6-5), amounting to approximately 4×10^7 kg within the total global atmosphere at an average concentration of 10–20 ng/m^3 (Whitehead 1984). The predominant source of iodine in the atmosphere is obtained from the transfer of iodine from the ocean to the surrounding atmosphere (FDA 1974). Evaporation of sea spray is one pathway through which iodine can enter the atmosphere. However, a high ratio (ca. 1,000) of iodine to chlorine measured in the atmosphere and rainwater in comparison to that found for seawater strongly suggests that other, more important pathways are responsible for the transfer of iodine from oceans and the surrounding atmosphere. These could include the photochemical or ozone-induced oxidation of iodide to elemental iodine (NCRP 1983; Whitehead 1984). Indeed, the concentration of ozone near the ocean surface could account for upwards of $6\text{--}12 \times 10^7$ kg of iodine released yearly into the atmosphere from the world's oceans. Yet, the concentration of iodine at the ocean's surface is too low to support this iodide oxidation mechanism as a major contributor to the transfer of iodine into the atmosphere. Instead, it has been suggested that the formation of methyl iodide and other alkyl iodides from the biological metabolism of iodine/iodide may, in fact, play a major role in the annual transfer of approximately $1.3\text{--}2.0 \times 10^9$ kg of iodine from the ocean into the atmosphere (NRC 1981; Rasmussen et al. 1982; Whitehead 1984). Under this mechanism, the methyl iodide that is transferred into the atmosphere can undergo photolytic dissociation into methyl and I radicals, with the resultant formation of elemental iodine and other forms of inorganic iodine (HI, HOI, INO_2 , IONO_2 , OIO, etc.) (Chameides and Davis 1980; Cox et al. 1999; Vogt et al. 1999). Other sources of iodine introduction into the atmosphere from the ocean include the release of particulate forms of iodine (IO_3^-), iodine-bearing particulates, and/or organically-bound iodine into the marine atmosphere with an airborne concentration ranging from 2 to 4 ng/m^3 (NCRP 1983; Vogt et al. 1999; Whitehead 1984).

The transfer of iodine from land surface(s) into the atmosphere also occurs, but to a much lesser extent than what is observed for the transfer of iodine between the ocean and atmospheric compartments (Figures 6-4 and 6-5). It is estimated that 1.6×10^6 kg/year of iodine is transferred into the atmosphere from surface soils and from the terrestrial biosphere, with an average airborne concentration of iodine ranging from 3 to 49 ng/m^3 as both the gaseous and particulate forms of organic and inorganic iodine (NRC 1981; Whitehead 1984). Iodine is transferred into the atmosphere from land sources through processes such as volatilization of iodine from soil and suspension of soil. For example, it is estimated that approximately 2×10^{10} g of iodine (as methyl iodide) volatilizes from rice fields world wide

Figure 6-4. Geochemical Cycle of Triad Elements (I, Br, Cl)

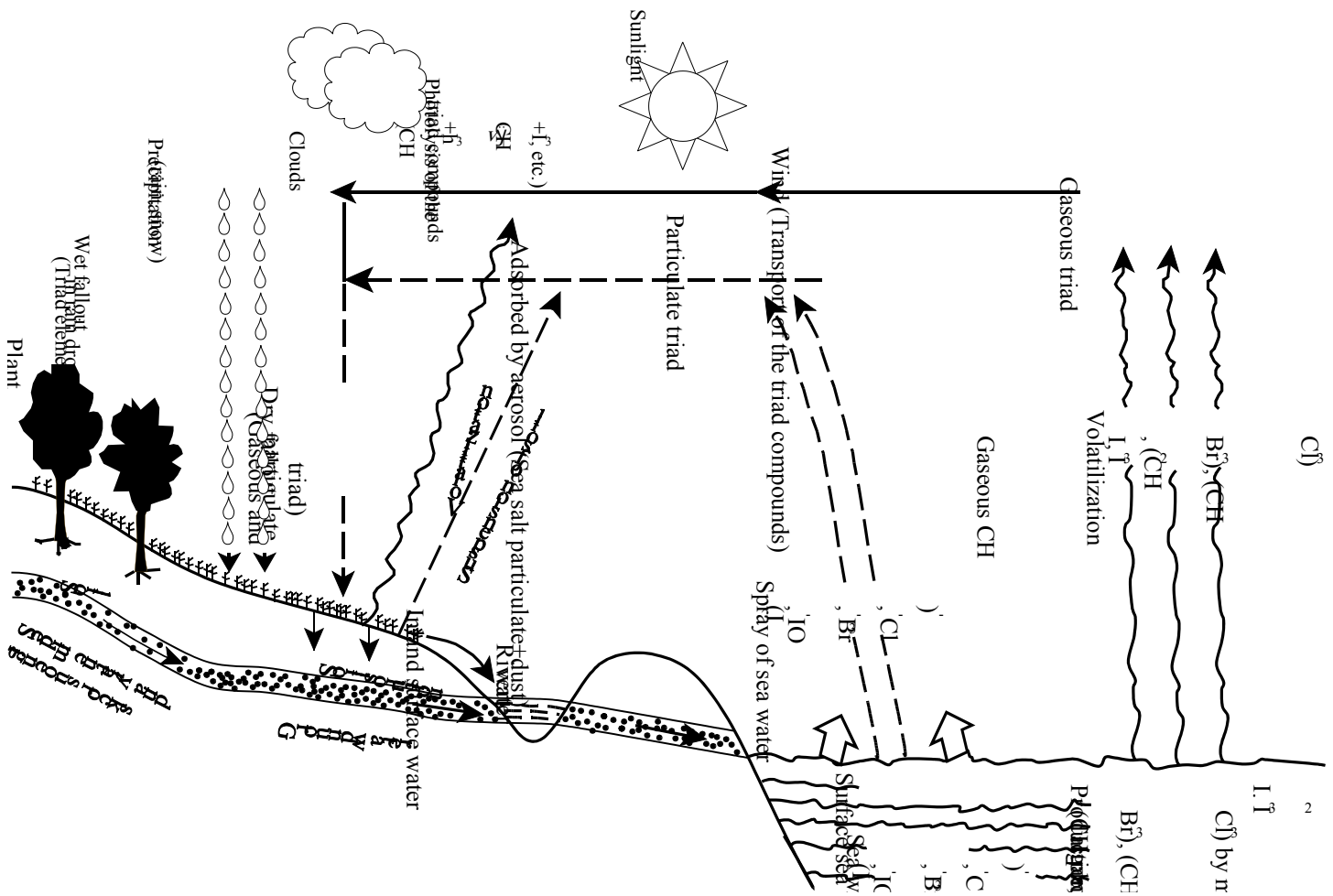

So
 urc
 e: Yuita 1994a

DRAFT FOR PUBLIC COMMENT

6. POTENTIAL FOR HUMAN EXPOSURE

Figure 6-5. An Outline of the Movement of Iodine in the Environment*

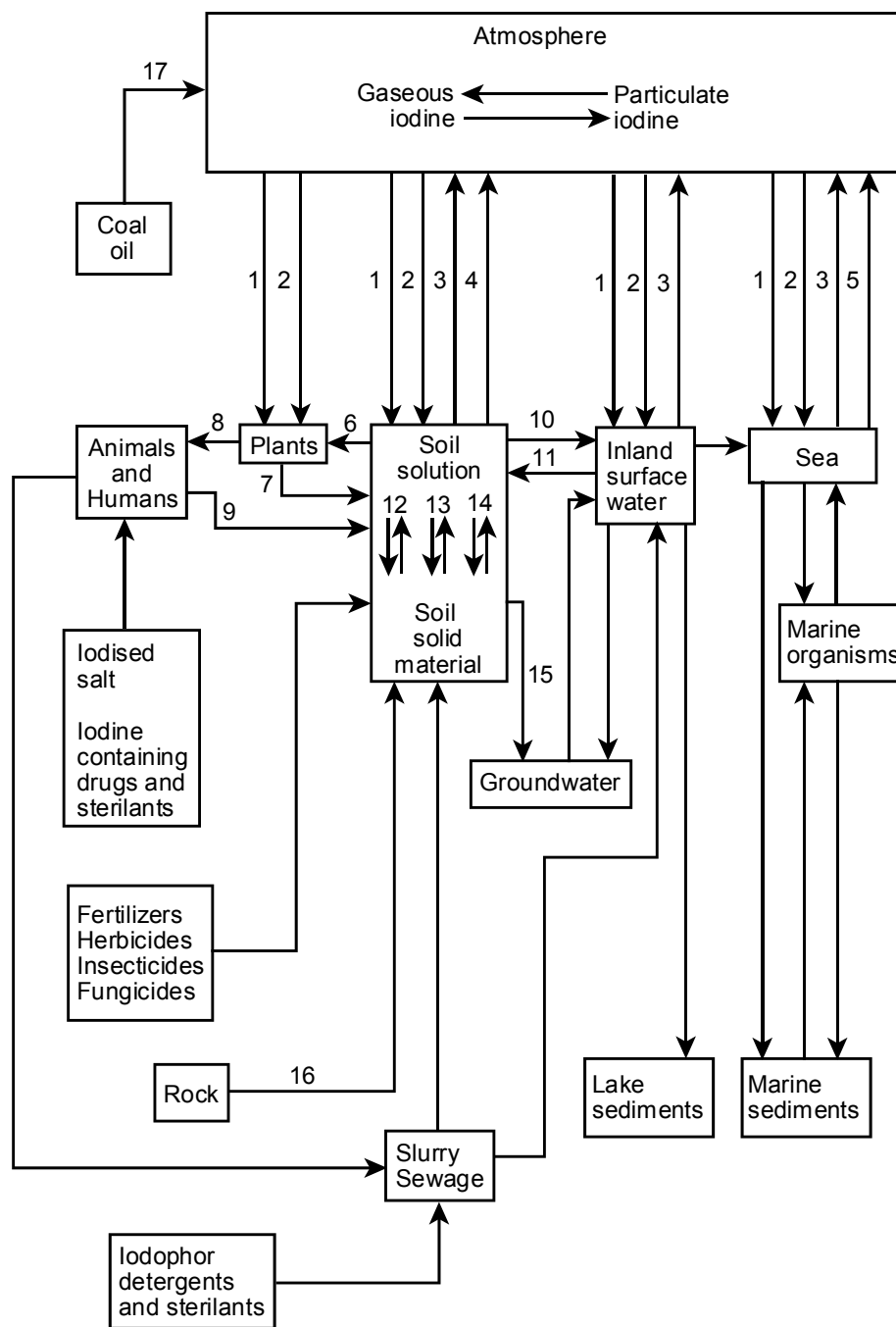

Source: Whitehead 1984

*1 = deposition in rainfall; 2 = dry deposition (including absorption by plant leaves); 3 = volatilization; 4 = suspension of dust; 5 = suspension of marine aerosols; 6 = uptake by plant roots; 7 = decomposition of plant residues; 8 = consumption of food; 9 = decomposition of animal excreta and residues; 10 = run-off; 11 = irrigation; 12 = non-specific adsorption/desorption; 14 = immobilization/mineralisation involving soil organic matter; 15 = leaching; 16 = weathering; 17 = combustion of fossil fuels

6. POTENTIAL FOR HUMAN EXPOSURE

(Muramatsu and Yoshida 1995). Like the atmosphere over the ocean compartment, iodine is found in the gaseous form ranging from 3 to 45 ng/m³ versus 0.5–6.9 ng/m³ bound to particulates (Whitehead 1984). The ratios of gaseous to particulate forms of iodine (2–5) and inorganic to organic forms of iodine (0.1–2) vary, depending on location (Whitehead 1984).

A natural radioisotope of iodine, ¹²⁹I, is also introduced into the atmosphere. Sources of ¹²⁹I include interaction of ¹²⁹Xe with high energy particles in the upper atmosphere and, to a lesser extent, spontaneous fission and the reaction of neutrons with ¹²⁸Te (tellurium-128) and ¹³⁰Te (tellurium-130) (NCRP 1983). This leads to a natural abundance of ¹²⁹I that varies between 10⁻¹² and 10⁻¹⁵ atoms per atom of the stable isotope of iodine, ¹²⁷I (Soldat 1976). This amounts to approximately 80 kg of ¹²⁹I in the surface environment (e.g., oceans, atmosphere, land) with 5x10⁻⁴ kg in the atmosphere (Moran et al. 1999). Because ¹²⁹I has a half-life of 1.6x10⁷ years, the introduction of this radioisotope into the atmosphere, and the environment as a whole, is cumulative from the standpoint of assessing human exposures.

Introduction of iodine and its radioisotopes can occur as a consequence of energy production, nuclear weapons production/utilization, and agricultural and medicinal/research uses. For the stable form of iodine (¹²⁷I), the introduction of iodine from these manufactured sources is much smaller than that observed for the introduction of iodine into the atmosphere from natural sources. However, the introduction of the radioisotopes of iodine (i.e., ¹²⁵I, ¹²⁹I, and ¹³¹I) into the atmosphere, and the environment as a whole, is derived mainly from human activities.

Combustion of fossil fuels also leads to the introduction of iodine from land-based sources (Figure 6-5). The average iodine content of coal is reported to be approximately 4 mg/kg, whereas petroleum contains iodine at an average concentration of 1 mg/kg (Chameides and Davis 1980). Based on fossil fuel (e.g., coal and petroleum) consumption estimates for 1971 of approximately 2,500 Mtoe/year (i.e., 2,500 million tons of oil equivalent per year), this would amount to approximately 4x10⁵ kg of iodine introduced into the atmosphere for that year (0.1% of the total iodine transferred to and from the atmosphere) (Bertine and Goldberg 1971; Whitehead 1984). At the current rate of global coal and petroleum consumption of approximately 3,000 Mtoe/year, the introduction of iodine into the atmosphere from this source for the year 2001 would be 5x10⁵ kg per year (IEA 2000; Whitehead 1984).

The production and use of nuclear materials for the generation of electrical energy has also contributed to the release of iodine and its radioisotopes. ¹²⁹I is formed in nuclear fission reactions of ²³⁵U and ²³⁹Pu with an atomic yield of 0.12% from uranium and 0.5% from plutonium. The yields of ¹²⁹I from the fission of ²³⁵U and ²³⁸Pu are 0.9 and 1.7%, respectively (AEC 1974). This gives an approximate ratio of 4 for ¹²⁹I/¹²⁷I in the fission of ²³⁵U and ²³⁸Pu. Since the nuclear fuel elements are contained in a metal cladding, the release of ¹²⁷I and ¹²⁹I that is produced in the fission reactions does not occur until the fuel is reprocessed. For example, it is estimated that the Savannah River fuel reprocessing plant released approximately

6. POTENTIAL FOR HUMAN EXPOSURE

2.8 kg/year of ^{129}I during 1964–1965, but has now fallen below 0.7 kg/year since the 1970s. This amounts to a total of 5.7 curies of ^{129}I released during the 1954–1989 operating history of the plant (Marter 1993). Releases of ^{129}I from the Hanford Reservation between 1944 and 1995 are estimated to be 1,900 GBq (290 kg) (Robkin and Sheien 1995). The releases of another iodine radioisotope, ^{131}I , during the years 1966–1972 was estimated to be 3×10^5 Bq (8×10^{-6} Ci)/MW(e)y from fuel reprocessing. From the Savannah site, an estimated 2,520 curies of ^{131}I was released from 1954 to 1989 (Marter 1993). The average releases of ^{131}I from boiling water reactors (BWR) ranges between 2×10^{-3} and 5×10^{-3} Ci/MW(e)y, and for pressurized water reactors (PWR), the values range from 5×10^{-5} to 50×10^{-5} Ci/MW(e)y (NRCC 1980).

Surface testing of nuclear weapons release of ^{129}I into the environment from nuclear explosions of ^{235}U and ^{239}Pu amounted to approximately 30 and 50 μCi per kiloton, respectively. Thus, it is estimated that atmospheric testing of nuclear weapons has released approximately 50 kg of ^{129}I into the atmosphere. The transport and diffusion of this radioisotope depended on initial height of the nuclear cloud and meteorological conditions; residency times were <0.5 years in the lower stratosphere and approximately 2 years at medium altitudes. Diffusion of radioisotopes from higher to lower altitudes then deposited through either precipitation or dry deposition (NCRP 1983); dry deposition could be as important as precipitation in surface deposition of iodine (Machta 1963; Straub et al. 1966). Release of ^{131}I also occurred during these surface tests of nuclear weapons; however, the ^{131}I that was released into the environment from these tests has decayed (half-life of 8.02 days) to levels that are no longer of concern in the environment.

Accidental releases of iodine and its radioisotopes are also sources of iodine introduction into the atmosphere. The 1986 Chernobyl reactor accident has released an estimated 1.3 kg of ^{129}I and 1,200–1,700 Bq (2.6–3.7 kg) of ^{131}I into the atmosphere (Likhtarev et al. 1993; Moran et al. 1999; Mould 2000). Other notable accidental releases of ^{131}I include the 1957 Windscale, United Kingdom, radiochemical plant fire and the Three Mile Island accident that released approximately 700 TBq (1.53 kg) and 0.6 TBq (1.3 mg) of ^{131}I , respectively (Likhtarev et al. 1993)

6.2.2 Water

Iodine, ^{129}I , and ^{131}I have been identified in 1, 1, and 1 groundwater samples, respectively, and no surface water samples collected from the 1,585 NPL hazardous waste sites, where it was detected in some environmental media (HazDat 2001).

Introduction of iodine into surface waters and groundwater occurs predominately through rainwater for noncoastal land regions and the combination of rainwater and ocean spray in coastal regions (Figures 6-4 and 6-5). It is estimated that 1.0×10^{11} g/year of iodine is deposited onto land surfaces, of which

6. POTENTIAL FOR HUMAN EXPOSURE

8.1×10^{10} g/year enters surface waters and 1.5×10^{10} enters groundwater (NRC 1981). The iodine in rainwater is derived from the transfer of iodine from the oceans to the atmosphere (FDA 1974).

Other natural releases of iodine into surface waters and groundwater include the leaching of iodine from the weathering of rock and volcanic activity (Figure 6-5). It is estimated that rocks contribute between 1×10^9 and 1.6×10^{10} g/year depending on the iodine content of the rock (0.5–8.8 ppm) (Cohen 1985). Volcanic activity can add an estimated 1.2×10^9 g of iodine per year to the surface environment, where the greatest contribution to the oceans is due to undersea volcanic activity (Miyake and Tsunogai 1963; NRC 1979).

Municipal waste water treatment plants introduce iodine and ^{131}I into surface waters, predominantly derived from human waste and the use of ^{131}I in medical treatments. Iodine is poorly captured within sludge (2–25%), with the remainder released into surface waters (1.0–16 $\mu\text{g/L}$) in the waste water stream (NAS 1974; Stetar et al. 1993).

Release of radioiodine has occurred as a result of the reprocessing of nuclear fuel. Release of ^{129}I from waste water generated by the Idaho National Engineering Laboratory into Snake River Plain aquifer through deep disposal wells (before February 1984) and unlined disposal ponds (1984–1990) amounted to approximately 0.56–1.18 curies (DOE 1994). This release in both shallow and deep groundwater horizons has been minimized through the recycling of the waste stream and storage of this stream with high-level radioactive waste. The Sellafield, United Kingdom and Cape de la Hague, France reprocessing facilities have cumulatively released 1,440 kg of ^{129}I directly into ocean waters since operations began in the 1960s; direct releases into the ocean amount to 200 kg/year since 1994 and have been increasing (Moran et al. 1999).

6.2.3 Soil

Iodine, ^{129}I , and ^{131}I have not been identified in soil or sediment samples collected from the 1,585 NPL hazardous waste sites (HazDat 2001).

The contribution of iodine to soils is derived from natural sources, such as the weathering of rock, decay of vegetation, iodine received from rainfall, and from human activities (Figures 6-4 and 6-5). Most soils contain, on average, approximately 5 mg/kg of iodine worldwide (Whitehead 1984). It is thought that only a small proportion of this iodine is derived from the weathering of rock (Fuge 1987; Goldschmidt 1958; Whitehead 1984), although there is some argument to the contrary (Cohen 1985). The natural content of iodine in natural geologic materials is (in ppm): ultramafic igneous (0.06–0.3), basaltic igneous (0.5), granitic igneous (0.5), shales/clays (212–380), deep sea clays (11–50), limestones (0.4–29), sandstones (1.7), and coals/ash (1–11) (NAS 1974). It is expected that the contribution of iodine to soils in regions

6. POTENTIAL FOR HUMAN EXPOSURE

where the bedrock is composed primarily of igneous rock will be much less than that for regions where the underlying bedrock is composed of sedimentary rock, which has a higher iodine content (Cohen 1985; NAS 1974; Whitehead 1984).

Wet deposition of iodine from the atmosphere in rain or snowfall contains an average of 2.0 µg iodine/L. Assuming an average precipitation rate of 800 mm (32 in) per year, the wet deposition of iodine would amount to the addition of 16 g iodine/ha²/year (Whitehead 1984). Dry deposition of iodine in a particulate form or bound to a particulate carrier can add an estimated 9.6 g iodine/ha²/year, assuming a deposition rate of 0.2 cm/second and an average concentration of 15 ng/m³ on particulate iodine (Whitehead 1984). However, the iodine that is derived from both the wet and dry deposition will only increase the content of the soil (to a 15 cm depth) approximately 0.7 ng/g if all the iodine is effectively trapped in the soil (Whitehead 1984).

Agricultural activities increase iodine in soils through animal excrement and the use of fertilizers/pesticides (Figure 6-5). Animal feces can contain up to 10 mg/kg iodine, and urine can contain up to 4 mg/L iodine. The iodine in sewage sludges and fertilizers used in agriculture can vary between 0.5 and 30 mg/kg. Most inorganic fertilizers contain <0.5 µg/g iodine, except fertilizers containing Chilean nitrate, which can provide upwards of 80 µg/g iodine. Superphosphate and compound fertilizers derived from rock phosphate can contain up to 26 µg/g iodine (Whitehead 1979). The use of fertilizers, however, will not result in an appreciable increase in the iodine content of soil (Whitehead 1984). Yet, the use of iodine-containing herbicides, such as ioxynil/ioxynil octanoate (recommended application of 0.5 kg/ha) and the fungicide benodanil (recommended application of 1.1 kg/ha), can increase iodine content of soil about 0.17 and 0.21 µg/g to a depth of 15 cm, respectively (Whitehead 1979, 1984).

Combustion of coal and petroleum is another source of iodine in soils. In the combustion of coal and petroleum, the iodine is introduced to the atmosphere through the flue gases. A large proportion (~ 80%) of the iodine released through the flue gases is deposited onto the surrounding soils by both wet and dry deposition, adding approximately 4x10⁵ kg iodine/year to soils globally.

6.3 ENVIRONMENTAL FATE

6.3.1 Transport and Partitioning

It is estimated that the earth's surface contains 6.3x10¹⁸ g of iodine. The majority of this iodine is in the earth's crust (3.4x10¹⁸ g) and in sedimentary rock (2.9x10¹⁸ g). However, this iodine is inaccessible, except for the small portion that is liberated through weathering processes (~ 10⁹ g/year) and eventually enters into the oceans. The ocean, on the other hand, is the largest compartment of accessible iodine that can be transferred to other environmental compartments. The earth's oceans contain 8.1x10¹⁶ g of iodine

6. POTENTIAL FOR HUMAN EXPOSURE

(Figure 6-6) at an average concentration of between 45 and 60 $\mu\text{g/L}$. Other environmental compartments with steady-state levels of iodine include atmosphere (8.8×10^{10} g), surface soil (4.1×10^{14} g), subsurface region (2.5×10^{13} g), and terrestrial biosphere (3.0×10^{11} g). The iodine in the ocean is in equilibrium with the iodine in ocean sediments (8.0×10^{17} g), with a net flux of 1.8×10^{11} g/year. A net transfer of iodine also occurs between the ocean surface and the global atmosphere at an average rate of 2.0×10^{12} g/year, of which 1.9×10^{12} g/year returns to the ocean through wet/dry deposition processes, and 1.2×10^{11} g/year is deposited onto land surfaces. Of the iodine that is deposited on land, 7.7×10^{10} g/year is returned to the ocean through groundwater and river effluents, and 1.6×10^{10} g/year enters into the terrestrial biosphere, of which 1.4×10^{10} g/year returns to the soil surface through weathering and decay of vegetation (NRC 1979).

The transfer of iodine between the ocean compartment, atmosphere, and land surfaces is due to the volatility of iodine in its molecular (I_2) and organic (most methyl iodide) forms. The extent to which iodine partitions into these compartments, and its residency time, will depend on the chemical form of the iodine as it enters into a specific compartment, any chemical alterations that the iodine undergoes in that particular compartment, and the solubility/uptake/retention of the various chemical forms of iodine in the compartment. The formation of alkyl iodides (predominantly methyl iodide) and, to a lesser extent, molecular iodine from biological activity and photochemical reactions on the ocean's surface, provide for the transfer of these iodine species into the ocean atmosphere, where they undergo further photochemical conversions into other gaseous and particulate forms of iodine (Cox et al. 1999; Filistovic and Nedveckait 1998; Vogt et al. 1999; Whitehead 1984). The relative proportions of iodine as inorganic particulates and organic gaseous forms is on average 25% for particulates and 40–80% for organic forms as methyl iodide (Moran et al. 1999). The residence times for iodine in the atmosphere are 14 days for particulates, 10 days for inorganic gases (i.e., I_2), and 18 days for organic gases (compared to a 9-day residency time for water vapor), providing for extended global transport and substantial mixing (Moran et al. 1999).

6. POTENTIAL FOR HUMAN EXPOSURE

Figure 6-6. Diagram of the Global Iodine Cycle at Steady State Showing Environmental Compartments, Compartment Inventories in Grams (g), Transport Pathways, and Fluxes in Grams per Year (g/year)

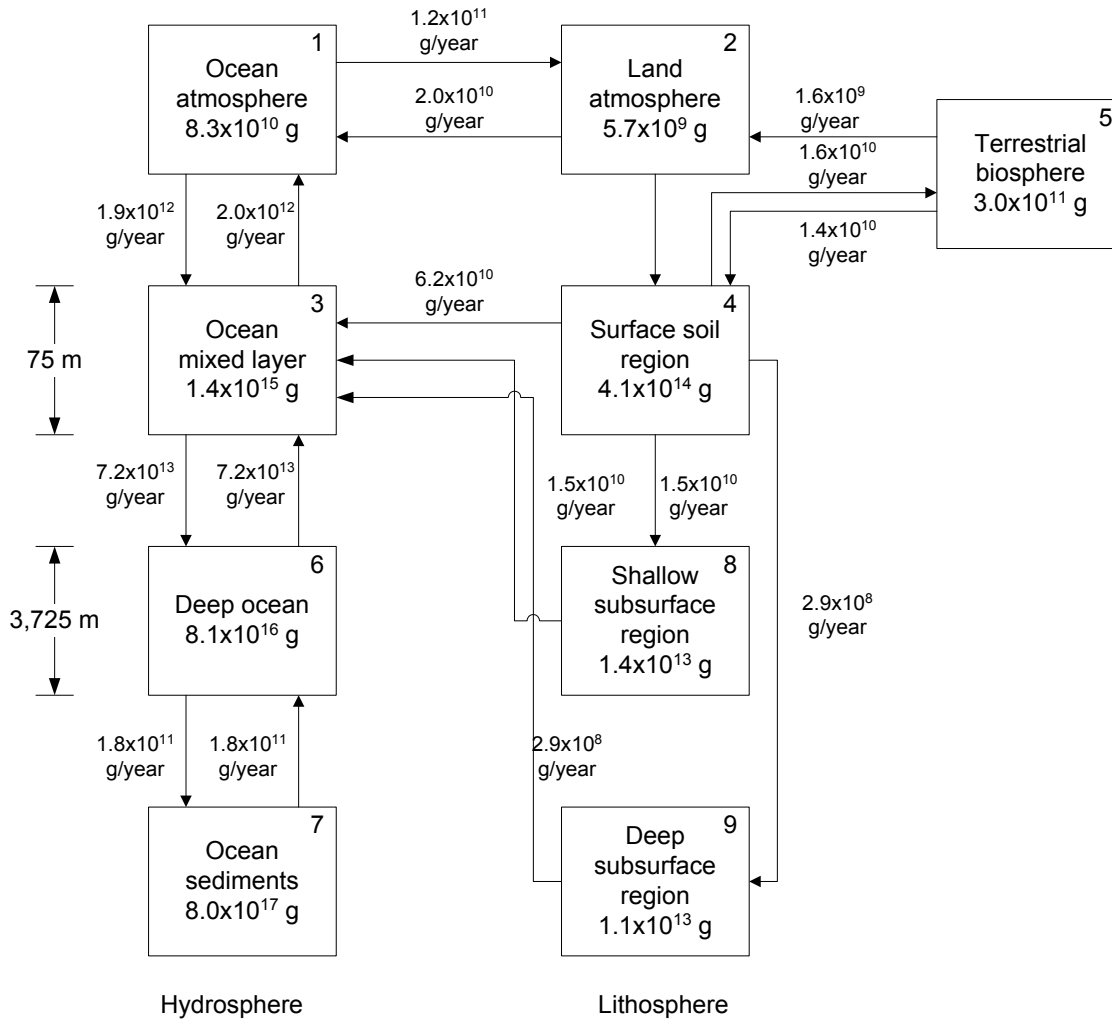

Source: Kocher 1981

6. POTENTIAL FOR HUMAN EXPOSURE

The gaseous and particulate forms of iodine in the atmosphere are deposited onto ocean or land surfaces through wet and dry deposition. Gaseous elemental iodine and particulate forms of iodine are susceptible to wet deposition, whereas methyl iodide has a low susceptibility. Accordingly, gaseous molecular iodine and particulate forms of iodine are susceptible to dry deposition; methyl iodide has a low susceptibility (Whitehead 1984).

The dry deposition rate is dependent on particle size, wind speed, and turbulence. Iodine will settle onto soil and plant surfaces. Direct deposition of iodine onto plant surfaces is limited to 7.5–14 days, where particulate iodine is removed from plant surfaces through weathering processes (AEC 1974; Heinemann and Vogt 1980; Kirchner 1994). Dry deposition onto plant surfaces is affected by the moistness of the surface; deposition is approximately 2-fold greater on moist plant surfaces versus dry surfaces (Heinemann and Vogt 1980). Also, dry deposition onto plants is affected by the surface area of the plant, as is evident from the 2-fold increase in iodine deposited on clover versus grasses (Heinemann and Vogt 1980).

The wet deposition of iodine will be predominantly deposited into soil. The relative amounts of iodine initially depositing onto the soil will greatly depend on the density and type of plant cover over the soil. Upwards of 90% of elemental iodine vapor can be intercepted by a dense cover of grassland herbage, but 40–70% can typically be expected to be intercepted by a more average density of plant cover (Whitehead 1984).

Evaporation of iodine from the land surface to the atmosphere is only about 1% of the flux of iodine from the atmosphere to the land surface (NRC 1979) and iodine is cycled back to the ocean through groundwater and river effluent (NRC 1979; Whitehead 1984). However, the overall content of iodine in a soil is determined by the inputs of iodine into the soil and the ability of the soil to retain iodine (versus leaching and volatilization), where the main input is from atmospheric deposition, both wet and dry, followed by degradation of plant material (mostly from adsorbed iodine) (Whitehead 1984).

The low flux of iodine from land surfaces to the atmosphere is due to the retention of iodine within surface soils, especially in soils rich in organic matter and iron/aluminum oxides (Sheppard et al. 1995). When the various chemical forms of iodine enter into the soil, these species are initially retained by their adsorbance onto soil components in equilibrium with their solubility in soil solution. Isotopic exchange studies indicate that between 5 and 30% of iodine is exchangeable (Whitehead 1984). Retention of inorganic and organic iodine will depend on both nonspecific and specific sorption onto soil components. Nonspecific ion-exchange interactions of iodide and iodate anions occur on free hydrous oxides of iron and aluminum; such exchanges involve electrostatic attractions and are dependent on pH and the concentration of other anions (Sheppard et al. 1995). Retention of molecular iodine in soil is thought to be mediated through the interaction of iodine with thiols and polyphenols present in the organic components of soils (Fawcett and Kirkwood 1953; Jirousek and Pritchard 1971; Whitehead 1984) and may also involve the

6. POTENTIAL FOR HUMAN EXPOSURE

oxidation/reduction of iodide and free radical reactions (Huang and Lu 1991). Methyl iodide is sorbed by soils to a lesser extent than inorganic iodide, but the factors that determine this sorption of methyl iodide to soils are unclear (Whitehead 1984).

Transport of iodine to lower soil depths is dependent on the porosity and saturation of the soil. Macropores formed from roots and earthworm channels allow for rapid transport of iodine into the soil. Mobility of iodine into the soil is greatest when the soil is saturated with water. The drier the soil, the thinner the water films within the soil, thus limiting the flow rate of water through the soil (Whitehead 1984).

In addition to the aforementioned direct deposition of particulate deposition of iodine onto plant surfaces, there is also evidence of the uptake of inorganic iodine into the plant through the roots and gaseous iodine through the leaves (Whitehead 1984). Iodide is more readily taken up into plant roots than is iodate or iodine (Burte et al. 1991; Whitehead 1984); the uptake is dependent on soil properties and the use of fertilizers (Moiseyev et al. 1984). Molecular iodine can be absorbed through the stomata in the leaves, whereas methyl iodide and hypoiodous acid are not as readily absorbed (Whitehead 1984).

Both the deposition of particulate iodine onto plant surfaces and the direct uptake of iodine into the plant factor into the transfer of iodine through the soil-plant-cow-milk pathway. The level of iodine in feed has a direct relationship with the level of iodine measured in milk (Tracy et al. 1989; Voigt et al. 1989) and is dependent on the season, nutritive quality of pastureland, and ambient temperature (Ekman et al. 1967; Lengemann and Wentworth 1979; Pennington 1990a). The transfer coefficient for iodine through the total pathway is approximately 0.003–0.01 for cow and 0.2 for goat, expressed as the fraction of daily intake per liter milk (d/L) (AEC 1974; Kirchner 1994; Voigt et al. 1988, 1989).

Transfer of iodine in the feed-meat pathway has also been determined in various animals and tissues. Transfer factors in whole animals (expressed as the fraction of daily intake per kg [d/kg]) are beef (0.02), pork (0.09), and chicken (0.004). The thyroid is the organ with the greatest uptake of iodine (AEC 1974). Individual tissue measurements have transfer factors range from 10^{-4} (kidney) to 10^{-3} (liver) to 10^{-2} (muscle) (Handl and Pfau 1989; Handl et al. 1990). Transfer factors have also been determined for feed-chicken eggs (0.03) (AEC 1974).

Iodine can also bioaccumulate to varying extents in aquatic organisms. Aquatic bioaccumulation factors for iodine in fresh water are 40 (algae), 5 (invertebrates), and 15 (fish); in salt water, these factors are 4,000–10,000 (algae), 50–100 (invertebrates), and 10–20 (fish) (AEC 1974). Certain seaweeds and algae can concentrate iodine to levels as high as 0.8–4.5 g/kg of dried material; these high levels are usually associated with the relatively high levels of iodine in seawater (50 µg/kg) (FDA 1974).

6. POTENTIAL FOR HUMAN EXPOSURE

6.3.2 Transformation and Degradation

Iodine consists of one stable isotope (^{127}I) and a number of radioisotopes, of which ^{125}I , ^{129}I and ^{131}I are the most common in environmental and occupational exposures. The radioisotopes ^{129}I and ^{131}I decay by β -emission to form ^{129}Xe and ^{131}Xe , respectively, whereas ^{125}I decays by electron capture, emitting gamma and Te x-rays. ^{125}I and ^{131}I disappear rapidly from the environment due to their short half-lives of 60 and 8.02 days, respectively, and do not undergo long-term accumulation in the environment. However, the long physical half-life of ^{129}I (1.57×10^7 years) means that any release of this radioisotope into the environment is essentially a permanent addition to the total inventory of iodine in the environment from the standpoint of assessing human exposures (NCRP 1983).

The chemical reactions of iodine and its radioisotopes within the environment are the same, but the ratios of the isotopes in these reactions may differ, depending on the relative concentrations of the isotopes in a particular environment. ^{127}I and its radioisotopes can exist in many forms and oxidation states (iodides [-1], molecular iodine [0], iodohalides [+1], iodates [+5], and periodates [+7]) (Holland 1963); organic forms of iodine include methyl iodide, ethyl iodide, isopropyl iodide, and methylene iodide (Vogt et al. 1999). Thus, “iodine” in the discussion of the chemical reactions of iodine in the environment will be used to refer to both iodine and its radioisotopes, unless indicated otherwise.

6.3.2.1 Air

The major source of iodine in air is from the evaporation of alkyl iodides (mostly methyl iodide) and, to a lesser extent, molecular iodine from ocean surfaces (Figures 6-4 and 6-7). At ordinary pressures and temperature, methyl iodide and iodine have high vapor pressures and will exist predominately in a free gaseous form in air. Both iodine and methyl iodide undergo photochemical reactions to form iodine radicals (IO), which can then go on to form a number of other iodine species through a complex series of reaction pathways (Cox et al. 1999; Filistovic and Nedveckait 1998; Vogt et al. 1999); some of these are shown below and in Figure 6-4.

Figure 6-7. A Simplified Scheme of Iodine Cycling in the Marine Boundary Layer*

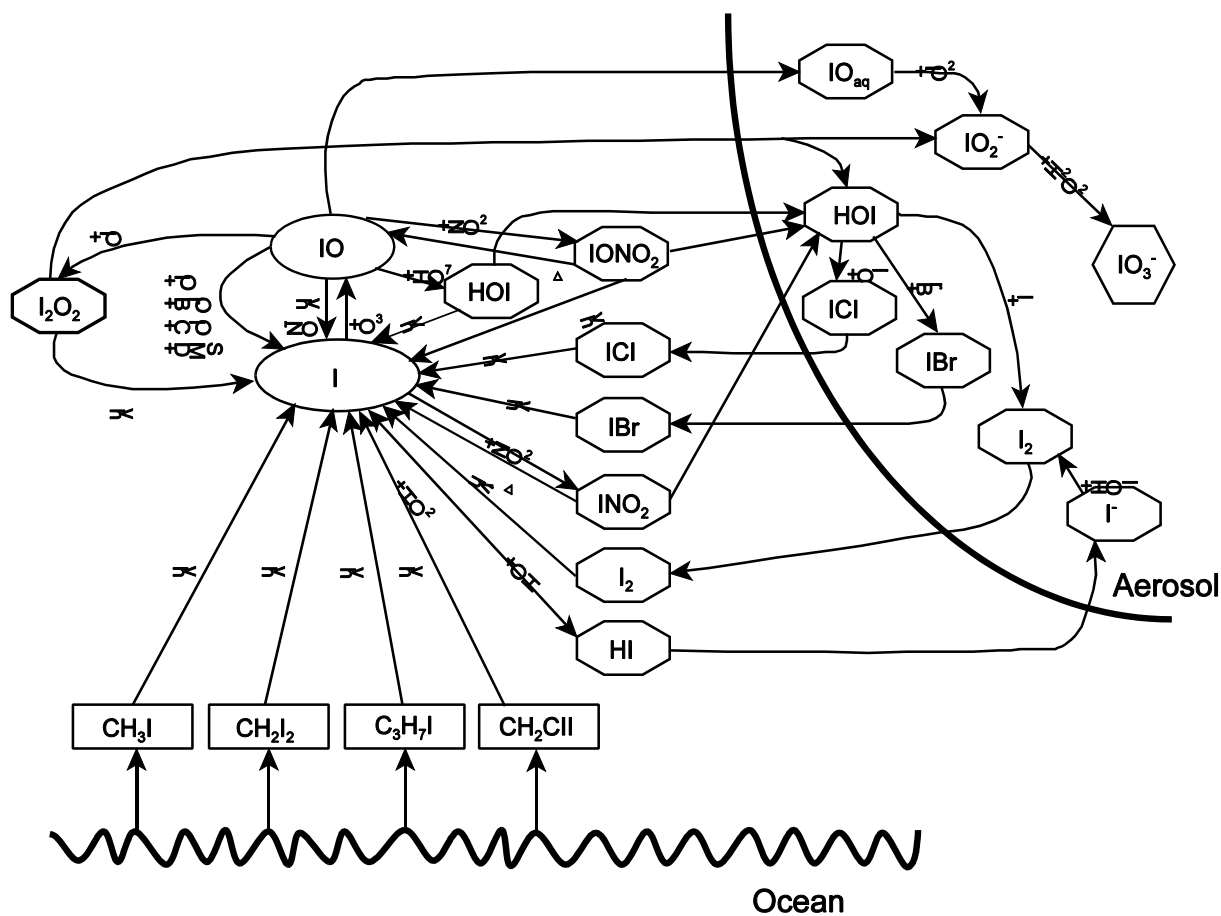

Source: Vogt et al.
1999

*Organic iodine compounds are shown in rectangular boxes; temporary iodine reservoir species in the gas and in the aerosol phase are shown in octagons.

6. POTENTIAL FOR HUMAN EXPOSURE

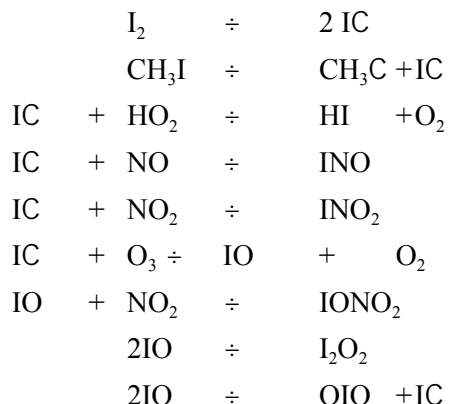

The overall photochemical dissociation of CH_3I and I_2 in the atmosphere results in the steady-state formation of inorganic iodine species consisting mostly of IONO_2 (75%), IO (15%), and $\text{HI} + \text{HOI}$ (10%) during the daytime, with only minor changes in these percentages during the night-time, IONO_2 (75%), IO (7%), and $\text{HI} + \text{HOI}$ (18%) (Filistovic and Nedveckait 1998).

Some of these iodine species (e.g., IO , I_2O_2) can then go on to react in aerosols or water droplets to form IO_2^- and IO_3^- (Figure 6-7). Gaseous iodine can also dissolve in water droplets to form iodide or hypoiodate ions, especially in the presence of alkaline impurities. Iodine is readily reduced to iodide by hydrogen sulfide and can be oxidized to free iodine by ozone, hydrogen peroxide, or possibly air and sunlight. If the iodine is acidified sufficiently, gaseous hydrogen iodide is liberated (Straub et al. 1966). Conversely, HI formed in air can dissolve in water droplets, forming iodide anions that can be oxidized to molecular iodine.

6.3.2.2 Water

Iodine in water exists as iodide and iodate. In rainwater, the relative proportion of iodide to iodate is 55:45. In surface waters, the proportion of iodide to iodate will vary depending on microbial activity and the release of iodine species from terrestrial sources (De Luca Rebello et al. 1990). Microbial action converts iodide to organic forms of iodine, primarily methyl iodide (iodomethane). The low vapor pressure and limited solubility in water promote the volatilization of methyl iodide from surface waters to the surrounding atmosphere. Likewise, microbial activity and photochemical reactions can lead to the formation of iodine from iodide or iodate; iodine can evaporate into the atmosphere due to its low vapor pressure.

6. POTENTIAL FOR HUMAN EXPOSURE

6.3.2.3 Sediment and Soil

Iodine can enter soil as I_2 , iodide, iodate, or methyl iodide through wet or dry deposition. Molecular iodine dissolves in soil water to form iodide or is oxidized to iodate. Conversely, chemical, and to a lesser extent, microbial, reduction of iodide or iodate forms molecular iodine that can evaporate from the soil water into the atmosphere. Iodine can react with organic components of soil, undergoing iodination reactions with polyphenols and tyrosine residues (Fawcett and Kirkwood 1953; Jirousek and Pritchard 1971; Whitehead 1984) that may involve the oxidation/reduction of iodide and free radical reactions (Huang and Lu 1991). Decreases in pH can alter the proportion of iodide to iodate in soil and water due to the protonation of iodide to form HI, which can volatilize into the atmosphere. The relative proportions of iodine species can also differ in soils under flooded and nonflooded conditions. The proportions of $I_2:I^-:IO_3^-$:organic iodine change from 0.045:0.065:0.89:0.016 under the oxidizing nonflooded conditions to 0.007:0.90:0.097:0 under the reducing flooded conditions (Yuita 1994a).

6.3.2.4 Other Media**6.4 LEVELS MONITORED OR ESTIMATED IN THE ENVIRONMENT****6.4.1 Air**

The average global air iodine concentration ranges between 10 and 20 ng/m³ with gaseous iodine usually exceeding particulate iodine by a factor of 2–6 (Whitehead 1984). Atmospheric concentrations over land range from 2 to 14 ng/m³, while atmospheric levels over oceans average between 17 and 52 ng/m³ (NRC 1979). In an urban air environment, iodine content in air over San Francisco in 1970 ranged between 4.7 and 10 ng/m³ over nine monitoring stations (John et al. 1973). In remote air environments, for example the arctic, the iodine concentrations fall dramatically. Iodine in the arctic stratosphere is 0.27 ng/m³, and is 0.33 ng/m³ at the marine boundary layer (Sheridan and Zoller 1989). The annual-average concentration of iodine in Canadian arctic air ranges between 0.43 and 0.96 ng/m³ (Barrie and Hoff 1985)

Iodine introduction in the form of methyl iodide emission from a municipal waste incineration plant has been measured at an average of 0.50 µg/m³ in Karlsruhe, Germany (Stieglitz 1995).

Radioiodine releases from nuclear fuel reprocessing facilities have been well documented. Discharges of ¹²⁹I from the Hanford Reservation between 1983 and 1992 ranged from 0.02 to 0.6 Ci/year, with a maximum output of 0.5–0.6 between 1986 and 1988 (DOE 1993). The average airborne concentrations of ¹²⁹I onsite ranged from 69–2,000 to 2.2–60 aCi/m³ along the perimeter to 0.13–2.4 aCi/m³ at distant

6. POTENTIAL FOR HUMAN EXPOSURE

monitoring sites (DOE 1993). At Savannah River, ^{129}I and ^{131}I releases between 1954 and 1989 totaled 5.67 and 2.52 Ci, respectively (DOE 1990).

The release of radioiodine into the atmosphere from nuclear weapons testing and its deposition onto distant targets has been measured. ^{131}I that was produced in the above-ground nuclear Test Harry and deposited (wet) on select New England monitoring sites ranged from 0.2×10^9 Bq/km in Buffalo to 3.4×10^9 Bq/km in Pittsburgh to 6.1×10^9 Bq/km in Binghamton (Hoecker and Machta 1990). The emissions of radioiodine are often associated with particulates. The amount of ^{131}I associated with particulates increases with the distance from the source of release. Upwards of 60% of ^{131}I released into atmosphere is associated with particulates, based on ground level measurements. It is assumed that 80–85% of the fallout of ^{131}I is in the reduced state, 15–20% is present as IO_3^- , and a few percent or more is present as IO_4^- (Perkins 1963; Straub et al. 1966). The cumulative release of ^{129}I (expressed as Ci) in nuclear weapons testing beginning in 1945 and ending in 1975 has been estimated and is shown in Table 6-1 (NCRP 1983).

6.4.2 Water

The average iodine content in seawater is 40–65 $\mu\text{g/L}$ (NRC 1979). The iodine content in rainwater averages between 0.1 and 15 $\mu\text{g/L}$, and in rainwater over oceans, the iodine content is 1–15 $\mu\text{g/L}$ (NRC 1979). The iodine content in river water averages between 0.1 and 18 $\mu\text{g/L}$ (NRC 1979). The concentration of iodine in river water will be locally influenced by municipal waste water streams. The average iodine content in municipal waste water effluent is 4.0 $\mu\text{g/L}$ (range 1.0–16 $\mu\text{g/L}$) (NAS 1974). In groundwater, the average iodine concentration is 1 $\mu\text{g/L}$ (Yuita 1994a).

The iodine content in drinking water typically varies between 0 and 8 $\mu\text{g/kg}$, with a more nominal range averaging between 2 and 4 $\mu\text{g/kg}$. Concentrations of iodine in drinking water approaching or exceeding 8 $\mu\text{g/kg}$ are usually associated with water that is directly contaminated with sewage or effluent from sewage discharge sites or from urban run-off (FDA 1974). For example, the concentration of iodine in the Potomac River was 4.0 $\mu\text{g/L}$ upstream of Alexandria, but increased to 8.0 $\mu\text{g/L}$ downstream. Sewage effluent from Alexandria was believed to be the cause. Some effluent streams can have iodine concentrations as high as 1,910 $\mu\text{g/L}$ (FDA 1974).

Seasonal variations in iodine have been measured in Rhode Island precipitation. The volume-weighted mean concentration in annual precipitation is 1.71 $\mu\text{g/L}$, with a concentration range of 0.04–11.3 $\mu\text{g/L}$. The seasonal variations in volume-weighted iodine concentration were 2.14 $\mu\text{g/L}$ during the warm season and 1.35 $\mu\text{g/L}$ during the cold season (Heaton et al. 1990).

6. POTENTIAL FOR HUMAN EXPOSURE

Table 6-1. Approximate Releases of ^{129}I from Atmospheric and High Altitude Nuclear Weapons Tests

Year	Cumulative ^{129}I Released (Ci)
1945–1951	0.04
1952–1954	2
1955–1956	3
1957–1958	5
1959–1961	6
1962–1963	10
1963–1975	10

Source: NCRP 1983

6. POTENTIAL FOR HUMAN EXPOSURE

Radioiodine is released into surface waters through the effluent of municipal sewage treatment plants. On an average working day, approximately 24 mCi of ^{131}I is released into the Ohio River, resulting in a concentration of 0.3 pCi $^{131}\text{I}/\text{L}$ downstream from the treatment plant (Sodd et al. 1975). The concentration of ^{131}I in water downstream from other municipal treatment plants throughout the United States has also been determined, ranging from 0 to 83 pCi $^{131}\text{I}/\text{L}$ (Prichard et al. 1981). The ^{131}I that has been measured in these waters is due to the introduction of ^{131}I into the sewer systems of cities from the excrement of patients undergoing treatments with this radioisotope.

The release of ^{129}I into surface waters has also been measured. It has been estimated that the above-ground total fission yield of a 207 megaton equivalent of plutonium fission devices contributed approximately 10 Ci of ^{129}I to the environment (NCRP 1983). Reprocessing of spent fuel could release additional amounts of ^{129}I into the environment (at most 2 Ci) depending on the amount of fuel that is reprocessed and the efficiency of gaseous effluent decontamination equipment. This has resulted in an increase in the ratio of $^{129}\text{I}/^{127}\text{I}$, which has been changing since 1945 due to release of ^{129}I into environment from nuclear weapon explosions and nuclear facilities. These releases range from 10^{-8} – 10^{-7} in the ambient environment to 10^{-4} – 10^{-3} near some nuclear facilities, as measured in thyroid tissues (NCRP 1983). The release of ^{129}I has also resulted in a steady-state inventory of 8.7×10^{26} atoms (31 Ci or 1.8×10^5 g) of ^{129}I in the oceans (AEC 1966).

The average content of ^{127}I and ^{129}I in air over the United States varies between 0.6 and 12.1 ppb (Table 6-2). These ^{129}I concentrations did not appear to differ greatly between coastal (e.g., Galveston, Texas) and interior (e.g., Lafayette, Indiana) measurement sites (Moran et al. 1999). The measured ratios of ^{129}I to ^{127}I in air and in precipitation was found to vary, ranging between 2.03 and 27.90 ($\times 10^{-12}$) in air and between 755–12,390 ($\times 10^{-12}$) in precipitation (Moran et al. 1999). These variations in the ratios of ^{129}I to ^{127}I may reflect the distances of the various collection sites from the sources of these isotopes (e.g., distance from coastal regions for ^{127}I and distance from nuclear fuel reprocessing facilities for ^{129}I) (Moran et al. 1999).

The effect of ^{129}I release from nuclear fuel reprocessing facilities on surface water and groundwater has been measured. In 1990–1991, ^{129}I concentrations in the Snake River aquifer at and near the Idaho National Engineering Laboratory range between 0.6 aCi/L and 3.82 pCi/L, with a mean of 0.81 pCi/L, which is a change from 1.30 pCi/L measured in 1986. This change reflects a decrease in the amount of ^{129}I disposal and changes in disposal techniques (DOE 1994).

Between January 1993 and June 1994, ^{129}I concentrations measured at 29 sites in and around the Savannah River site in surface waters ranged between 0.027 and 3.2 pCi/L (Beals and Hayes 1995).

Table 6-2. Concentration of Iodine, Chloride, and ¹²⁹I/¹²⁷I Ratio in Air and Precipitation as a Function of Location and Collection Time

Location ^a	Air		Rain/Snow		Cl ⁻ (ppm)	I/Cl
	I (ppb)	¹²⁹ I/ ¹²⁷ I (10 ⁻¹²)	¹²⁹ I/ ¹²⁷ I (10 ⁻¹²)	¹²⁹ I atoms/L (10 ⁷)		
WL 12/95-2	1.4	12.03	5,756	3.7		
WL 12/95-3	0.9	12.45	8,327	3.7	0.2	0.0045
WL 12/95-4	0.6	13.85	12,390	3.7		
B 11/95	1.2	7.38	2,027	1.1	1.6	0.0008
CS 8/22/96	6.6	10.39	755	2.3		
CS 9/1/96–9/15/96	1.9	4.17	913	2.4	0.3	0.0061
CS 9/15/96–10/15/96	2.5					
CS 10/20/96–10/26/96	2.0				1.2	0.0017
CS 10/26/96–11/24/96	1.7	2.03	893	0.7	1.1	0.0015
CS 11/24/96–11/30/96	3.3				1.6	0.0021
CS 12/21/96–1/16/97	2.9	26.80	3,408	4.5		
CS 1/20/97–1/30/97	2.5	7.60	2,121	2.5		
CS 2/20/97–2/26/97	1.8	5.30	975	0.9		
CS 3/18/97-1	1.4					
CS 3/18/97-2	1.3					
CS 3/18/97-3	0.6					
CS 3/18/97-4	0.8					
CS 3/18/97-5	0.7					
G 1/96–10/96	1.9	9.44	1,735	1.6		
G 11/96	12.1	27.90	1,064	6.0	46.5	0.0003

DRAFT FOR PUBLIC COMMENT

IODINE

6. POTENTIAL FOR HUMAN EXPOSURE

Table 6-2. Concentration of Iodine, Chloride, and ¹²⁹I/¹²⁷I Ratio in Air and Precipitation as a Function of Location and Collection Time (continued)

Location ^a	Air		Rain/Snow		Cl ⁻ (ppm)	I/Cl
	I (ppb)	¹²⁹ I/ ¹²⁷ I (10 ⁻¹²)	¹²⁹ I/ ¹²⁷ I (10 ⁻¹²)	¹²⁹ I atoms/L (10 ⁷)		
G 12/6/96–1/6/97	1.7				4.9	0.0003
G 1/7/97–1/16/97	1.2	14.87	3,946	2.3		
Ohio snow 1/14/97	0.7	11.10	9,150	3.0		

^aWL = West Lafayette, IN; B = Bryan, TX; CS = College Station, TX; G = Galveston, TX

Source: Moran et al. 1999

DRAFT FOR PUBLIC COMMENT

6. POTENTIAL FOR HUMAN EXPOSURE

6.4.3 Sediment and Soil

The natural occurrence of iodine in igneous and sedimentary rock is approximately 0.2–5.8 ppm, 5–10 times higher in shales rich in organic matter, in soils, and in coals (NAS 1974). Some references indicate that these estimates may be low, suggesting instead an average soil content for iodine as high as 5.85 ppm (range: 1.5–13.5 ppm) (NAS 1974). Indeed, in one survey of iodine content in soils (Table 6-3), the iodine concentration in common soil types is consistent with the mean of 5.85 ppm (Whitehead 1979). This survey also shows the large variation in iodine concentrations as a function of soil type (Whitehead 1979, Table 6-3). In a study of the iodine concentration of soils in the contiguous United States, the average iodine concentration in soils was 1.2 µg/g. This average does not differ between soils measured in the western United States (west of 96th meridian) (1.2 µg/g) or the eastern United States (1.2 µg/g) (USGS 1984). Iodine concentration in soils has also been measured as a function of soil depth (Table 6-4), showing minimal variation in iodine concentration to depths of 12–24 inches (Fuge 1987). The data in Table 6-4 also show that soil concentrations were typically higher than the concentration of iodine in the underlying bedrock.

The iodine content in sewage sludges ranges between 1.0 and 17.1 µg/g dry weight; these values are similar to those found in soils, with the mean for iodine in sludges generally being lower. Iodine content of sludges was not related to size or degree of industrialization of a particular city or town. Measurements of iodine in sludge indicate that iodine does not partition strongly into sludges (Whitehead 1979). ¹³¹I content in sludge generated from the Oak Ridge municipal waste water plant averages 0.16 nCi/L. The background concentration of ¹³¹I content in sludge generated at a municipal sewage treatment in Ann Arbor, Michigan, was reported to be 1.4 pCi/L, but could rise as high as 15 pCi/L (Fenner and Martin 1997). These concentrations of ¹³¹I in sewage sludge are due to the introduction of ¹³¹I into city sewer systems from the excrement from patients that are treatment therapies that utilize ¹³¹I (Stetar et al. 1993)

The soil content of ¹²⁹I has been compared to ¹²⁷I and has been found to be generally higher near nuclear fuel reprocessing facilities than elsewhere. The ¹²⁹I/¹²⁷I ratios near facilities range between 10⁻⁴ and 10⁻³, whereas more remote locations yield ratios between 10⁻⁹ and 10⁻⁸ (Robens and Aumann 1988).

6.4.4 Other Environmental Media

Iodine content of aquatic plants varies, depending on whether they are fresh or salt water. Freshwater algae contain 10⁻⁵% by weight of iodine, whereas marine algae contain 10⁻³% by weight (NCRP 1983).

6. POTENTIAL FOR HUMAN EXPOSURE

Table 6-3. Iodine Content in Specific Soil Types

Soil	Concentration of iodine ($\mu\text{g/g}$ dry soil)	
Acid igneous rocks and associated till	10.4	(4.4–15.7) ^a
Till associated with basic igneous rocks	10.9	(3.4–16.3)
Slate, shale, and associated till	9.8	(4.4–27.6)
Sand and sandstone	3.7	(1.7–5.4)
Chalk and limestone	12.3	(7.9–21.8)
Clay	5.2	(2.1–8.9)
River and river terrace, alluvium	3.8	(0.5–7.1)
Marine and estuarine alluvium	19.6	(8.8–36.9)
Peat	46.8	(18.7–46.8)

^aAverage iodine concentration with the range of measurements given in the parentheses

Source: Whitehead 1979

6. POTENTIAL FOR HUMAN EXPOSURE

Table 6-4. Iodine Content in Missouri Soils as a Function of Depth and Parent Material

Bedrock	Soil depth (inches)	Iodine concentration (µg/g)
Sandstone	0-5	0.80
	5-8	0.78
	8-12	1.05
	Bedrock	<0.04
Dolomite	0-4	0.89
	4-8	0.85
	8-12	1.13
	12-18	1.08
	18-24	1.28
	Bedrock	<0.04
Alluvium-river valley	0-3	0.91
	3-6	0.65
	6-12	0.72
	12-18	0.91
Limestone (thin soil)	0-3	5.98
Shale	0-6	1.02
	6-12	1.03
	12-18	1.13
	Bedrock	0.37
Granite	0-5	2.90
	5-10	5.00
	10-15	7.21
	Bedrock	<0.04
Glacial material	0-5	0.12
	5-10	0.31
	10-15	0.68
	15-20	0.28
	20-24	0.53

Source: Fuge 1987

6. POTENTIAL FOR HUMAN EXPOSURE

Epiphytes (plants that have no root systems and acquire their nutrients from the air), such as Spanish moss in the southern United States, are used to measure long-term exposures of airborne trace elements. The concentration of ^{129}I in Spanish moss varies between 0.4 and 4.9 ppm and roughly correlates with estimated airborne concentrations of ^{129}I (Moran et al. 1999). In Norway, the iodine in moss averages 3.3 ppm (Schaug et al. 1990).

The average content of iodine in terrestrial plants has been reported to be 0.42 mg/kg worldwide (Yuita 1994a). In some specific examples, iodine content (mg/kg) has been measured at 0.60–2.6 in beet root flesh; 0.1–2.4 in cabbage head; and 0.30–1.1 in corn kernel (Sheppard et al. 1993). The iodine content in hay has been measured at 0.08 $\mu\text{g/g}$ fresh weight feed (Voigt et al. 1988). The distributions of I_2 in plants, such as wheat, can vary over the various parts of the plant. In wheat, iodine concentrations ($\mu\text{g/mg}$) change between shoots (0.136), roots (0.206), and total plant (0.153). For iodide, the distribution throughout the plant differs as well. In wheat, the iodide concentrations ($\mu\text{g/mg}$) are 0.645 in shoots, 0.100 in roots, and 0.261 in plant (Voigt et al. 1988).

The ^{129}I content in deer thyroids has been assessed as a function of proximity to a nuclear fuel processing facility. The ^{129}I thyroid concentrations were highest in deer captured near the nuclear fuel reprocessing plant at the Savannah River Site, South Carolina (1–102 Bq/g thyroid in 6.8% of deer) and Oak Ridge, Tennessee (0.01–1.0 Bq/g thyroid in 38% of deer). However, no thyroids from deer in Florida or in west Tennessee, which are distant from nuclear fuel processing facilities, contained ^{129}I at concentrations above 4 mBq/g thyroid (Van Middlesworth 1993).

Iodine measurements in milk and milk products have yielded the following results (expressed as $\mu\text{g}/100\text{ g}$): low fat milk (24), skim milk (21), buttermilk (24), chocolate milk (25), plain lowfat yogurt (33), strawberry lowfat yogurt (17), evaporated milk (37), half-and-half (17), cottage cheese (27), American cheese (49), cheddar cheese (47), chocolate fast-food milkshake (55), chocolate ice cream (47), vanilla ice milk (30), ice cream sandwich (51), and chocolate instant pudding (36) (Pennington 1990a).

Measurements of ^{131}I have been monitored in milk through the Environmental Radiation Ambient Monitoring System (ERAMS) using gamma spectral analysis of milk samples taken from 65 monitoring sites with at least one located in each U.S. state, Puerto Rico, and the Panama Canal Zone. The most recent measurements of ^{131}I in milk samples taken from July–September 1993 through July–September 1997 are below the detection limit at all monitoring sites (see ERD 1993 and ERD 1997 for examples).

6. POTENTIAL FOR HUMAN EXPOSURE

6.5 GENERAL POPULATION AND OCCUPATIONAL EXPOSURE

Exposure and uptake of iodine and its radioisotopes can be obtained through several routes including inhalation, transepidermal absorption, dietary intake, use of medications, and medical procedures. The uptake, distribution, and effect of these exposures varies depending on the iodine isotope and the population of interest. These points are discussed below.

Inhalation Exposures. Inhalation exposure of the general population to iodine through inhalation represents an intake pathway. Normal human respiratory exposure to iodine has been estimated to be 5 µg/day from an atmospheric exposure of 0.7 µg/m³ (FDA 1974). Uptake of ¹²⁹I through inhalation is a minor pathway for human intake of this radioisotope. It has been calculated that approximately 4x10⁻⁵ g/year of ¹²⁹I is taken up by the average individual (NRC 1979).

Epidermal Exposures. Iodine vapor can penetrate through the skin. Iodine penetration through the epidermis was measured under controlled conditions in which volunteers were exposed to various concentrations of ¹³¹I in the air (3.1–350x10⁻¹⁰ Ci/L) (Gorodinskii et al. 1979). Entry of ¹³¹I through inhalation was prevented through the use of a specially designed head mask connected to a clean air supply line. Penetration of ¹³¹I through the epidermis was monitored by ¹³¹I uptake in the thyroid (3.1–303x10⁻¹⁰ Ci), as measured by a scintillation sensor. K values were calculated to compare the uptake of ¹³¹I in the thyroid (A_m) versus the ¹³¹I concentration in the air (C), where $K=A_m(Ci)/C(Ci/L)$. The K values varied between 0.7 and 2.9, indicating individual variations in iodine penetration through the skin and uptake of iodine into the thyroid. The results of this study also suggest that the value A_m after a 4-hour exposure to iodine vapor can be approximated using the relationship $A_m=3C$. A comparison of the penetration of iodine through the skin to the penetration of iodine through the lungs in previous work shows that entrance of iodine through the skin is 1–2% of its entrance through the lungs.

Dietary Intake of Iodine. The average daily dietary intake of iodine varies considerably, depending on the diet. Vought and London found individual daily intakes of iodine to vary from 15 to as high as 1,540 µg iodine/day, with mean intakes varying from 64 to 379 µg/day (FDA 1974). The recommended dietary allowance for iodine is 0.150 mg/day for adults and adolescents (FDA 1989b).

Several studies have attempted to describe the daily intake of iodine as a function of diet and age grouping. Hospital diets were measured to have mean iodine intakes of 0.533 mg/day (range 0.274–0.842 mg/day), 0.677 mg/day (range 0.595–0.713 mg/day), and 0.377 mg/day (range 0.246–0.506 mg/day) (Caplan et al. 1976; Pittman et al. 1969). One nursing home diet had an intake of 1.531 mg/day (Caplan et al. 1976). The daily iodine intake in children has also been measured: 8–15 years old (0.450 mg/day) (Trowbridge et al. 1975), 6-month-old infants (0.359 mg/day, range 0.182–0.576), 2-year-old children (0.435 mg/day,

6. POTENTIAL FOR HUMAN EXPOSURE

range 0.231–0.728), and 15–20-year-old males (0.527 mg/day, range 0.319–0.827) (Pennington et al. 1984).

Dietary iodine intakes have been examined among age groups and were measured to be (in mg/day): 6–11 months old (0.200), 2-year-old children (0.460), 14–16-year-old girls (0.420), 14–16-year-old boys (0.710), 25–30-year-old women (0.270), 25–30-year-old men (0.520), 60–65-year-old women (0.250), and 60–65-year-old men (0.340) (Pennington et al. 1986). The average daily iodine intake partitioned by food category (expressed as $\mu\text{g}/\text{day}$) for men and women in the age group 20–34 years old has also been reported and is shown in Table 6-5 (FDA 1974)

Drinking Water/Beverages. Human exposures to iodine through drinking water are typically too low to provide for significant uptake of iodine. Surface waters rarely exceed 5.0 μg iodine/L, except where waters are polluted with municipal waste stream effluent or urban run-off; in these cases, iodine concentrations can be as high as 8.7 $\mu\text{g}/\text{L}$ (FDA 1974). Some beverages, such as beer and wine, have iodine contents in the ranges of 43–46 and 8–32 $\mu\text{g}/\text{kg}$, respectively, which could provide a significant amount of iodine to the diet, depending on their level of daily consumption of these beverages (FDA 1974).

In emergency, camping, or military uses of iodine to disinfect water supplies, iodine concentrations approach 8–16 mg/L (Zemlyn et al. 1981). Use of elemental iodine in the disinfecting of water, when improperly used, can lead to acute iodine toxicity. Tetraglycine hydroperoxide is more commonly used at a concentration of 8 mg/L to provide more accurate and reliable delivery of iodine to disinfect drinking water. Prolonged (>7 days) use of iodine as a water disinfectant can lead to mild impairment of thyroid function (Georgitis et al. 1993).

Food Exposures. The human diet is the major source of exposure to iodine for the general human population. Although marine seafoods typically contain the highest amount of iodine (160–3,200 $\mu\text{g}/\text{kg}$ fresh basis, mean 660 ± 180 $\mu\text{g}/\text{kg}$), they constitute only a small part of the American diet. The largest sources of iodine in the human diet come from vegetables (320 ± 100 $\mu\text{g}/\text{kg}$), meat products (260 ± 70 $\mu\text{g}/\text{kg}$), eggs (260 ± 80 $\mu\text{g}/\text{kg}$), and dairy products (130 ± 10 $\mu\text{g}/\text{kg}$) (FDA 1974). The level of iodine in vegetables depends upon the type of plant (e.g., spinach has by far the highest content among the common vegetables) and whether iodine was present in fertilizers. The content of iodine of eggs and milk (milk products) depends on the dietary intake of chickens and lactating cows. Eggs accumulate systemic iodine; however, systemic levels are controlled by the limit that is placed on the content of iodine in feed or water (12.5 mg/kg or liter). Similarly, the content of iodine in milk is dependent upon iodine intake, in addition to the seasonal climatological variables, level of milk production, and fullness

6. POTENTIAL FOR HUMAN EXPOSURE

Table 6-5. Estimated Average Iodine Intake for Adults in the United States

Food Category	Average daily consumption		Average daily iodine intake	
	Male (g/day)	Female (g/day)	Male (µg/day)	Female (µg/day)
Milk and milk products	397	269	51.6	35.0
Eggs	55	31	14.3	8.1
Meat and meat products	325	192	84.5	49.9
Seafood	14	9	9.2	5.9
Legumes	40	24	–	–
Grain and cereal products	12	81	12.2	8.1
Yellow and green vegetables	104	88	33.3	28.2
Other vegetables and fruits	96	56	3.8	2.2
Sugar and sweets	44	35	–	–
Beverages (excluding milk)	749	739	3.0	3.0
Estimated salt intake	3.42	3.42	142.0	142.0
Iodine in food as additives	–	–	100.1	100.1
Total			454.0	382.5

Source: FDA 1974

6. POTENTIAL FOR HUMAN EXPOSURE

of the mammary gland. One source of iodine in the cow's diet is the addition of potassium iodide to feed. However, the iodine content of milk varied between regions and even between individual farms. These variations were found to be caused, in part, by differences in the use of iodized salt blocks, exposures of cows to iodine in disinfectants, and the presence of iodine in sanitizers and veterinary medications (FDA 1974).

Food sources of iodine that have caused adverse effects in humans include water, seaweed, ground beef containing thyroid tissue, foods to which iodine was added as a supplement (iodized water, bread, salt), and milk that contained iodine resulting from feed supplements and iodophor disinfectants (FDA 1989b). For example, iodine in seaweed-based supplements was found to be 0.045–5.0 mg/dose (Norman et al. 1988). The value of 5.0 mg/dose is approximately 30 times higher than the RDA for iodine and 5 times higher than the value of 1.0 mg/day, where acute and chronic toxicities for iodine intake begin to be seen (Pennington 1990). Outside of these sources of high dietary iodine, the average iodine content in various food groups (expressed as $\mu\text{g}/\text{kg}$ wet weight) are: seafoods (660 ± 180), vegetables (320 ± 100), meat products (260 ± 70), eggs (260 ± 80), dairy products (130 ± 10), bread and cereals (100 ± 20), and fruits (40 ± 20) (FDA 1974).

The iodine contained in milk can be readily transferred to milk products, such as cheeses and ice cream. Typically, milk has been shown to contain iodine at concentrations ranging from 0.100 to 0.770 mg/L (Pennington 1988). Cheeses containing levels as high as 425 $\mu\text{g}/\text{kg}$ have been reported (FDA 1974). The high concentrations of iodine in milk and in some milk products are thought to be derived from the use of iodophor disinfectants and sanitizers in the practice of dairy farming and the processing of milk. As a topical disinfectant, the concentration of iodine in iodophors is 0.5–1.0% by weight. Iodophors with an iodine concentration of 0.001–0.0025% have been used to disinfect equipment and used in teat dips and udder washings. Teat dipping can increase the iodine content in milk by an average 174 $\mu\text{g}/\text{L}$ (range, 55–353 $\mu\text{g}/\text{L}$). However, there is evidence that the major contributor to iodine content in milk is feed supplementation rather than the use of iodophors (FDA 1974).

Processed foods, such as breads, have also been shown to be a source of iodine in the human diet. Potassium iodate is used as a conditioner of bread dough by some, but not all, major bakeries. When used as a dough conditioner, a concentration of 1–2 μg iodide/g bread is typically obtained. Iodine content of fast food, ranging from McDonald's french fries to a filet-of-fish sandwich, varied between 20 and 84 $\mu\text{g}/100$ g total product, respectively (FDA 1974).

Food additives can also contribute to human iodine intake; table salt contains cuprous iodide and potassium iodide, alginic acid, and alginate salts that are used as emulsifiers, and stabilizers and thickeners which contain upwards of 9 mg/kg iodine, but may only constitute an average intake of 1 $\mu\text{g}/\text{person}/\text{day}$

6. POTENTIAL FOR HUMAN EXPOSURE

(FDA 1974). Iodized salt in the United States provides 0.076 mg iodine/g (0.418 mg per teaspoon) (FDA 1989b).

Distribution of Iodine in Human Tissues. Iodine concentrations in nonthyroid tissues of recently deceased individuals obtained from a healthy Chinese population have been assessed using neutron activation analysis techniques (Hou et al. 1997b). Typical intake of iodine in the Chinese diet averages between 94 and 169 µg/person/day (Hou et al. 1997a). The concentrations of iodine in five tissues, plus hair, averaged over 9–11 individuals and expressed as (ng/g wet weight tissue±1 SD) were: heart (46.6±14.9), liver (170±34), spleen (26±8.6), lung (33.3±10.6), muscle (23.5±14.3), and hair (927±528) (Hou et al. 1997b).

Exposures Through Medications/Medical Uses of Iodine. Human exposures to iodine may come from medications and vitamin supplements containing iodine in varying amounts. A survey of various pharmaceuticals found that of those tested, eight contained between 0.251 and 0.375 mg iodine per dose, with one containing 1.447 mg I/dose (Vought et al. 1972). The variation of iodine content could be attributed to the use of erythrosine (2,4,5,7-tetraiodofluorescein) as a red coloration (FDA 1974). Erythrosine can be metabolized in the digestive tract to liberate iodide, although the bioavailability of iodine from erythrosine may be only 2–5% (FDA 1989b). Some medications directly contain added potassium iodide or organic iodine compounds. For example, Lugol's solution that is used to treat thyrotoxicosis is a 5% solution of iodine solubilized in 10% potassium iodide. Other iodine-containing drugs (most commonly potassium iodide solutions) have been prescribed for their purported expectorant for action in asthma, bronchitis, cystic fibrosis, and chronic pulmonary obstructive disease; also, amiodarone is prescribed for heart arrhythmias (FDA 1989b). Topical application of iodine-containing medications and dietary supplements can increase iodine in breast milk in lactating women; use of povidone iodine vaginal gel (50 mg/day for 6 days) increased iodine concentration in breast milk by 3–4 times (FDA 1989b).

Large exposures to iodine can be experienced during certain medical procedures, for example, through the use of iodinated compounds as contrast agents in radiological imaging procedures. Iodine in oil is used in bronchograms, lymphangiograms, and for myelograms, and is excreted slowly, thus predisposing an individual to imbalances in iodine homeostasis.

Radioiodine -¹³¹I. The greatest periods of exposure to ¹³¹I (and other radioiodine isotopes derived from nuclear fission) were during active nuclear testing in the years 1951–1958 and 1961–1962, the large quantities of fission products released from nuclear accidents such as Three Mile Island and Chernobyl, and the nuclear processing and waste facilities (e.g., Hanford, Washington; Aiken South Carolina; Idaho Falls, Idaho). Human uptake of ¹³¹I from environmental sources is largely through ingestion of contaminated food, with a smaller proportion obtained through inhalation (Straub et al. 1966; Wehmann

6. POTENTIAL FOR HUMAN EXPOSURE

1963). The distribution of ^{131}I in food depends upon the time the isotope is produced, its presence in the environment, and the degree of contamination. Some potential dietary sources of ^{131}I include marine animals and plants, milk, and leafy vegetables (Straub et al. 1966).

The largest source of ^{131}I in the human diet is cow's milk. Approximately 70% of the ^{131}I that is consumed by a cow is absorbed into the thyroid, with about 1% found in milk (milk-to-plasma ratio of ^{131}I is 2:3) (Bustad et al. 1964; Lengemann and Comar 1964; Straub et al. 1966). The transfer of iodine is bi-directional, and the iodine appears to freely diffuse between mammary gland and plasma (Miller and Swanson 1963; Straub et al. 1966). ^{131}I exists in both the free inorganic form, as iodide, or bound to protein in milk. It has been determined that in cow's milk, 82–91% of the ^{131}I is in the free inorganic form, with 4.7–13% bound to protein and <0.1% associated with fat (Glasscock 1954; Straub et al. 1966).

The occurrence and concentration of ^{131}I in milk is highly variable, depending on the locale and daily variations within a specific locale (Pennington 1990a). Due to meteorological conditions, a large proportion of ^{131}I from fallout is deposited on the ground through dry deposition processes, with a lesser amount deposited through wet deposition processes (i.e., precipitation) (Straub et al. 1966). The highest concentrations of ^{131}I in milk were observed shortly after atmospheric tests of nuclear weapons and accidental releases from nuclear reactors or fuel reprocessing facilities (Anderson et al. 1996; Black et al. 1976; Cohn and Gusmano 1963; Kirchner 1994; Martin and Turner 1964; Tracy et al. 1989; Tubiana 1982; Voigt et al. 1989). The source of ^{131}I in cow's milk is derived mainly from the dry and wet deposition (to a lesser extent uptake into plants from the soil) of ^{131}I onto grasses and other plants that are then consumed by dairy cows. A concentration of 1 $\mu\text{Ci } ^{131}\text{I}/\text{kg}$ of ^{131}I in pasture grass yields a ^{131}I concentration of 0.07 $\mu\text{Ci } ^{131}\text{I}/\text{L}$ of milk (Voigt et al. 1989).

In cases of exposure to ^{131}I , the absorbed dose has been estimated in various tissues and whole body for the ingestion of 1 mCi of ^{131}I . The values for the absorbed doses (expressed in cGy and based on the assumption of a 25% uptake of ingested ^{131}I into the thyroid) are: 0.48 (liver), 0.14 (ovary), 0.26 (bone marrow), 1.4 (gastric mucosa), 0.088 (testis), and 1,300 (thyroid), with a mean whole body dose of 0.71 cGy (Tubiana 1982).

The levels of ^{131}I in domestic and imported foods measured between 1987 and 1992 were found to be below the detection limit of the gamma-ray spectrometry method (<2 Bq/kg) (Cunningham et al. 1994). Detection and quantitation of ^{129}I is difficult due to the low energy of the beta (maximum energy=0.15 MeV) and gamma rays (0.04 MeV) that are emitted from this isotope. Concentration of ^{129}I in thyroid tissues increases the ability to detect this isotope, but further limitation results from the low specific activity of the radioisotope (0.17 mCi/g) (NCRP 1983). However, due to the steady-state levels of ^{129}I in the environment, there is a continual exposure of the general human population to this radioisotope through inhalation and intake through the diet. It has been estimated (AEC 1974) that a dose of

6. POTENTIAL FOR HUMAN EXPOSURE

approximately 0.2–0.5 mrem/year is delivered to the thyroid of an adult from ^{129}I , depending on diet. These estimates include the dose received through the inhalation of ^{129}I . For an infant, the doses to the thyroid from ^{129}I intake can vary between 0.15 and 0.4 mrem/year, depending on diet.

6.6 EXPOSURES OF CHILDREN

This section focuses on exposures from conception to maturity at 18 years in humans. Differences from adults in susceptibility to hazardous substances are discussed in 3.7 Children's Susceptibility.

Children are not small adults. A child's exposure may differ from an adult's exposure in many ways. Children drink more fluids, eat more food, breathe more air per kilogram of body weight, and have a larger skin surface in proportion to their body volume. A child's diet often differs from that of adults. The developing human's source of nutrition changes with age: from placental nourishment to breast milk or formula to the diet of older children who eat more of certain types of foods than adults. A child's behavior and lifestyle also influence exposure. Children crawl on the floor, put things in their mouths, sometimes eat inappropriate things (such as dirt or paint chips), and spend more time outdoors. Children also are closer to the ground, and they do not use the judgment of adults to avoid hazards (NRC 1993).

Children appear to be more susceptible to the development of thyroid cancers from the irradiation of thyroid by ^{131}I . Irradiation of the thyroid from a 1–2 Gy dose in Japanese A-bomb survivors and a 3.3 Gy dose in Marshall Islanders exposed to fallout results in a high incidence (factor of 2) of thyroid cancers in children under the age of 10 compared the exposed adult population (Tubiana 1982).

Of the iodine radioisotopes, ^{129}I poses the least risk to children with respect to thyroid irradiation. Even at a high thyroid content of 1 mCi ^{129}I in 1 g of stable iodine, the dose to the thyroid in a 6-month-old infant would be 0.9 nGy/year as compared to a dose of 7.2 nGy/year in an adult thyroid. In comparison, ^{131}I can deliver much higher doses to the thyroid at lower environmental concentrations than those observed for ^{129}I , due to the higher specific activity of ^{131}I (1.24×10^5 Ci/g; beta particle energies of 0.334 MeV [7.3%] and 0.606 MeV [89.9%]) versus ^{129}I (177 $\mu\text{Ci/g}$; beta particle energy of 0.154 MeV) (Chu et al. 1999; Robkin and Schleien 1995). For example, the annual consumption of milk containing ^{131}I at a concentration of 1–20 nCi/L would result in a dose to the thyroid in children of between 0.005 and 0.1 cGy/year (Tubiana 1982). In comparison, similar concentrations of ^{129}I in milk would yield thyroid dose of between 0.014 and 0.28 pGy/year, based on the specific activities and beta energies listed above. Breast milk is also a source of ^{131}I uptake in children. For example, concentrations of ^{131}I in breast milk measured in women exposed to nuclear weapons fallout ranged between 0.050 and 0.100 nCi/L, when the mean body burden of ^{131}I in these women was 0.060 nCi (Cohn and Gusmano 1963).

6. POTENTIAL FOR HUMAN EXPOSURE

Children (both 1 and 10 year olds) appear to have a similar fractional uptake of iodine in the thyroid (i.e., approximately 31%) of that found in adults. For newborns, however, the fractional uptake is approximately 70% at 2 days after birth, but quickly declines to values accepted for an adult by day 5. After the first few weeks, uptake changes very little with age. Estimated dietary intake of iodine in 1 year olds is 151 $\mu\text{g}/\text{day}$, and for 10 year olds, it is 184 $\mu\text{g}/\text{day}$. The percent turnover rates of iodine in the thyroid does change with age (expressed as d^{-1}) are: 0–4 years old (3.4 ± 0.5), 4–8 years old (2.1 ± 0.5), and 8–12 years old (0.84 ± 0.36); this corresponds to ‘apparent’ half-lives of 20, 33, and 83 days, respectively. Iodine concentration in thyroid increases with age (expressed as $\mu\text{g}/\text{g}$): 1 year old (95), 2 years old (130), 4 years old (180), 10 years old (260), 16 years old (320), and adult (400) (Stather and Greenhalgh 1983).

In utero exposures of a human fetus to iodine radioisotopes with high specific activity (e.g., ^{131}I) have been assessed based on both the maternal intake of iodine radioisotopes and exposure to external radiation generated by these isotopes in the immediate environment. Iodine and its radioisotopes freely diffuse across the placenta and, as such, their levels within a fetus and the amniotic fluid will depend greatly on the concentration of iodine within the mother (Baši. et al. 1988; Dyer and Brill 1972; Etling et al. 1979; von Zallinger and Tempel 1998). Before 11 weeks of gestation, the thyroid is still undeveloped and does not actively take up iodine (Dyer and Brill 1972; von Zallinger and Tempel 1998). For example, the percent of iodine that is taken up by the thyroid in comparison to that contained in the total fetal tissues is quite low at a gestation age of 9–11 weeks (0.0002%), but increases after 11 weeks where the percentage becomes 0.001% for gestation ages between 13 and 15 weeks, and increases further to 0.002% between gestation ages of 16 and 22 weeks (Dyer and Brill 1972). A difference in placental transfer of iodine between the mother and fetus is also noted as a function of gestation time. The percentage of ^{131}I activity found in the fetus compared to the total activity within the mother at 11 weeks was 0.23%, but increased to 2.96% at 22 weeks due to the fact that the concentration of iodine in the fetal thyroid typically exceeds that of the maternal thyroid by 3–10 times (von Zallinger and Tempel 1998). Increases in the concentration of iodine in the fetus and amniotic fluid (6- to 90-fold increases) were observed in women exposed to topical iodine-containing medications (e.g., vaginal therapy with iodinated polyvinylpyrrolidone) or increased iodine intake in their diets (Etling et al. 1979). However, the uptake of iodine (measured by ^{131}I uptake) into the fetal thyroid (1.08 pCi/g) at a gestation time of 22 weeks is not significantly different from what is observed for the maternal thyroid (0.82 pCi/g) (Beierwaltes et al. 1963).

Emission of ionizing radiation from iodine radioisotopes can also pose an exposure risk to the human fetus and the mother in occupations where the mother comes in contact with these isotopes. For example, fetal doses in imaging staff performing a whole body scan and/or therapy procedures for thyroid cancer patients using ^{131}I ranged between 6.7 and 9.0 μSv (Mountford and Steele 1995). Thus, restrictions on the exposure of pregnant women are 1.3 mSv to the maternal abdominal surface (corresponding to a 1.0 mSv dose to the fetus) (Mountford and Steele 1995).

6. POTENTIAL FOR HUMAN EXPOSURE

6.7 POPULATIONS WITH POTENTIALLY HIGH EXPOSURES

Occupational Exposures (Medical Personnel, Laboratory Personnel, Personnel at Nuclear Power/Fabrication/Storage Facilities). Occupational exposures to airborne iodine can occur when iodine is used in the regular functions of the workplace. OSHA has set a limit for airborne iodine concentrations in the workplace of 0.1 ppm. Exposures of workers to concentrations at or in excess of the OSHA limit can often occur. For example, at a plant that processes photo-polymer plates, most workers were exposed to an average concentration of iodine of 0.005 ppm, but were exposed to concentrations of 0.122–0.146 ppm when they were in the immediate proximity of the iodine holding tank or iodine applicator (Kim et al. 1981).

Workers in the nuclear industry, especially in nuclear fuel reprocessing facilities, have the potential for chronic thyroid burdens of ^{131}I in addition to acute exposures from accidental releases. For example, in Indian workers, the dose from chronic ^{131}I exposures was found to be as high as 47.4–68.1 rem for thyroid and 0.024–0.047 rem for whole body (Raghavendran et al. 1978). In an acute exposure to ^{131}I in a steam leak at a nuclear power plant, the mean thyroid burden of ^{131}I in the exposed workers was 1.32 μCi on the third day after the exposure; the ^{131}I burden decreased exponentially, falling below 0.027 μCi on the 38th day (Bhat et al. 1973).

Internal contamination of medical personnel by ^{131}I can be a problem, especially under conditions where the release of iodine as a vapor can occur (Eadie et al. 1980; Luckett and Stotler 1980). Thyroid burdens of ^{131}I in medical personnel can typically average around 2,400 pCi (ranges of 35–18,131 pCi) (Blum and Liuzzi 1967). Personnel working with ^{131}I could potentially receive up to 5 nCi per mCi handled. This means that persons handling therapeutic doses of ^{131}I could have activities of 0.1–1.0 μCi in their thyroids (Tubiana 1982). For the application of ^{131}I in nuclear medicine, it has been shown that the radiochemists and their support staff have a yearly thyroid ^{131}I burden of between 0.5–200 and 0.03–1.5 nCi, respectively (Jönsson and Mattsson 1998).

External exposures of medical personnel to radiation emitted from radioiodine have been assessed for both diagnostic and therapeutic applications of ^{131}I and ^{125}I . The dose rate per unit activity ($\mu\text{Sv/h @MBq}$) of ^{131}I has been determined for thyrotoxicosis, thyroid ablation, and thyroid cancer therapies as a function of distance from the patient. The dose rate as a function of distance is approximately the same for all three therapy regimens; 1.43 $\mu\text{Sv/h @MBq}$ at 0.1 meter, 0.18 $\mu\text{Sv/h @MBq}$ at 0.5 meter, and 0.07 $\mu\text{Sv/h @MBq}$ at 1.0 meter (Mountford and O'Doherty 1999). Surgical implants of ^{125}I seeds in prostate brachytherapy have the potential for radiation exposures to the radiotherapist. However, in most instances when the implant procedure is performed properly, the dose rate is $<1 \mu\text{Gy/mCi-hour}$ (Liu and Edwards 1979).

6. POTENTIAL FOR HUMAN EXPOSURE

Laboratory workers using ^{125}I are at risk for exposures to gamma- and x-rays to the hand. In a typical situation where 20 MBq (5 mCi) of ^{125}I from an unshielded source is used weekly (2 hours/week) throughout a year, a worker would receive a dose of approximately 225 mSv (22.5 rem), 3/10 of the recommended dose equivalent limit to the hands (de Groot 1979). Uptake of ^{125}I into the thyroid has also been shown to occur due to airborne radioiodine released from solutions or spills (Bogdanove and Strash 1975; Dunn and Dunscombe 1981; Krzesniak et al. 1979; Kwok and Hilditch 1982). Activity levels of 0.013–0.024 and 0.056–0.56 μCi have been measured in the thyroid of a laboratory worker working with 1 and 5 mCi of ^{125}I in the day's activities, respectively (Kivinitty et al. 1984). In a more general survey, it was found that 8% of laboratory technicians working with ^{125}I labeled materials had thyroid burdens of ^{125}I within 9–90 nCi. However, 33% of those individuals involved in the direct iodination of biomaterials and compounds with ^{125}I had thyroid burdens of 9–90 nCi (Pomroy 1979).

Patients Undergoing Medical Treatment Involving Use of Iodinated Compounds. Patients undergoing treatment for hyperthyroidism and thyroid carcinoma typically receive between 10 and 150 mCi of ^{131}I (Beierwaltes 1979). In addition to the thyroid, other tissue sites in the patient also receive a radiation dose, albeit a smaller dose. This is especially important when considering the impact that ^{131}I can have on bone marrow in a patient undergoing ^{131}I therapy to treat thyroid carcinomas. During these ^{131}I therapies, the bone marrow can receive a dose of 1–5 Gy (Tubiana 1982). This has been shown to lead to a 1% incidence of leukemia in these patients (Tubiana 1982).

There is also an exposure risk of a patient's immediate family to both the radiation and elemental ^{131}I that is emitted from the patient (Barrington et al. 1999). Patients are allowed to return home after the activity of ^{131}I within them falls below 30 mCi. However, this level of ^{131}I activity in a patient can produce an exposure rate to ionizing radiation of approximately 10 $\mu\text{Gy}/\text{hour}$ at a distance of 1 meter. Thus, family members are also at risk to exposures to ^{131}I that is emitted from the patients. The dose that a typical family member receives from a patient at home ranges between 0.17 and 126 $\mu\text{Gy}/\text{day}$, as compared to the natural radiation background of 0.35 $\mu\text{Gy}/\text{day}$ (Jacobson et al. 1978). This can result in some family members exceeding the maximum allowable dose of mSv (1 mrem) per year. In another study, it was found that as many as 11% of children exposed to patients undergoing ^{131}I therapy exceeded the 1 mSv limit (Barrington et al. 1999). Activities of ^{131}I within the thyroids of family members of patients undergoing ^{131}I therapy were found to range from the detection limit of the measurement of 92–110,000 pCi, resulting in a dose of 4–1,330 mrem to the thyroid. Of special concern is the fact that the ^{131}I activity was highest in children (Jacobson et al. 1978).

A growing number of patients who are undergoing treatment for cancer are using alternative medicines and nutritional supplements (Cassileth 1999). It is believed that these alternative medicines and supplements will help to prevent the onset of a tumor, alleviate specific symptoms that are experienced as a consequence of their disease or treatment, or aid in the eradication of the tumor. The self administration of

6. POTENTIAL FOR HUMAN EXPOSURE

some of these alternative medicines and nutritional supplements can result in the intentional (e.g., elevated iodine intake to prevent breast cancer) or unintentional (e.g., when iodine is a natural component of a specific alternative medicine) elevation of the daily intake of iodine, especially when patients consume alternative medicines that contain salt water plants, such as kelp, or those individuals who take megavitamins or participate in orthomolecular therapy (Cassileth 1999). The amount of iodine intake will vary depending on the specific content of iodine in the supplement and the dosage, which could result in iodine intakes that approach toxic levels (e.g. >6 g/day). For most cancers, it is unclear what benefit increased iodine will have for the prognosis of the disease or how it can alter the incidence of a particular cancer (Cann et al. 2000; Cassileth 1999; Eskin 1970). However, there is evidence to suggest that elevated iodine intake, especially for populations where ambient iodine concentrations are low, can help to decrease the incidence of breast cancer and, in some cases, help to interfere with breast tumorigenesis (Cann et al. 2000; Eskin 1970).

Diseases/Predisposition to Iodine Toxicities. An increase in the availability of dietary iodine for a population may also cause difficulty in controlling Graves' disease with antithyroid drugs, decrease the remission rates for those on antithyroid medication, and increase the dose of radioiodine required to induce euthyroidism (FDA 1989b). In the general population, between 0.2 and 33.3% of individuals develop goiter in response to excess iodine consumption, whereas an increase in the incidence of sensitivity or acute reactions was observed in <30% of individuals in the general population (FDA 1989b).

6.8 ADEQUACY OF THE DATABASE

Section 104(i)(5) of CERCLA, as amended, directs the Administrator of ATSDR (in consultation with the Administrator of EPA and agencies and programs of the Public Health Service) to assess whether adequate information on the health effects of iodine is available. Where adequate information is not available, ATSDR, in conjunction with the National Toxicology Program (NTP), is required to assure the initiation of a program of research designed to determine the health effects (and techniques for developing methods to determine such health effects) of iodine.

The following categories of possible data needs have been identified by a joint team of scientists from ATSDR, NTP, and EPA. They are defined as substance-specific informational needs that if met would reduce the uncertainties of human health assessment. This definition should not be interpreted to mean that all data needs discussed in this section must be filled. In the future, the identified data needs will be evaluated and prioritized, and a substance-specific research agenda will be proposed.

6. POTENTIAL FOR HUMAN EXPOSURE

6.8.1 Identification of Data Needs

Physical and Chemical Properties. Adequate pertinent data on the physical and chemical properties of iodine and its radioisotopes and compounds are available in the literature.

Production, Import/Export, Use, Release, and Disposal. Since iodine is not covered under SARA, Title III, manufacturers and users are not required to report releases to the EPA. There is a lack of data on the release and disposal of iodine. There is a relatively good database on the release of radioiodine (Beals and Hayes 1995; DOE 1990, 1994; NCRP 1983; Patton and Cooper 1993), but only limited information is available on disposal and inventories of radioiodine in disposal sites (DOE 1994).

Environmental Fate. The major source of iodine on terrestrial surfaces originates from the volatilization of iodine from the ocean surface. Adequate information is available pertaining to the chemical species and reactions that take place at and above the ocean surface that are responsible for the production of volatile forms of iodine (Cox et al. 1999; Filistovic and Nedveckait 1998; Vogt et al. 1999; Whitehead 1984). Further work is needed to examine the organisms and microbial metabolic processes that are responsible to the formation of alkyl iodides, as well as the exact contribution of alkyl iodides, molecular iodine, and spray to the introduction of iodine into the atmosphere. There is a good body of literature on the photochemical reactions of iodine, both in the gaseous phase and in/on particulates or water droplets (Cox et al. 1999; Filistovic and Nedveckait 1998; Moran et al. 1999; Vogt et al. 1999; Whitehead 1984). The factors that are responsible for the retention of iodine in soil have also been examined extensively (Fawcett and Kirkwood 1953; Jirousek and Pritchard 1971; Sheppard et al. 1995; Whitehead 1984). However, more work is needed to characterize the interactions of iodine with organic components, especially with respect to the mechanisms of the binding and release of iodine from these organic components. The environmental fate of ^{129}I and ^{131}I has been examined extensively (AEC 1974; DOE 1978a, 1986; NRC 1979, 1981).

Bioavailability from Environmental Media. Adequate pertinent data for intake of iodine and radioiodine from inhalation, drinking water, and food intake are available (DOE 1993; NCRP 1983; NRC 1979; Whitehead 1984).

Food Chain Bioaccumulation. Concentrations of iodine in freshwater and marine fish have been determined (Poston 1986). Concentrations of iodine in aquatic plants have also been ascertained (NCRP 1983). Although aquatic plants and fish concentrate iodine in their tissues, there is little evidence for bioaccumulation of iodine in the food chain. Iodine and radioiodine concentrations have been measured in foods, especially in the context of milk and the transfer of radioiodine through the soil-plant-cow-milk pathway (AEC 1974; Kirchner 1994; Tracy et al. 1989; Voigt et al. 1988, 1989). Although some

6. POTENTIAL FOR HUMAN EXPOSURE

information is available, more information is needed on the uptake of iodine from the soil into plants (Burte et al. 1991; Moiseyev et al. 1984; Whitehead 1984).

Exposure Levels in Environmental Media. Adequate pertinent data are available for current exposure of iodine in air, rainwater, surface water, groundwater, and soil (FDA 1974; Moran et al. 1999; NRC 1979; Whitehead 1984; Yuita 1994a).

Exposure Levels in Humans. A good database exists for exposure levels of the general population to iodine and its radioisotopes in various food types and drinking water (Allegrini et al. 1983; Bruhn et al. 1983; Dellavalle and Barbano 1984; Kidd et al. 1974; Pennington et al. 1986), including exposure levels in milk (Pennington 1988). Information for the average daily intakes of iodine based on diet and age groupings is available (Caplan et al. 1976; Pennington et al. 1984, 1986). Information on occupational exposures is available, especially for exposure of medical personnel to ^{131}I and laboratory workers to ^{125}I (Blum and Liuzzi 1967; Bogdanove and Strash 1975; de Groot 1979; Dunn and Dunscombe 1981; Krzesniak et al. 1979; Kwok and Hilditch 1982; Mountford and O'Doherty 1999; Pomroy 1979; Tubiana 1982). Data exist for distribution of iodine in human and fetal tissues, but more information is needed (Dyer and Brill 1972; Hou et al. 1997b; von Zallinger and Tempel 1998).

Exposures of Children. A good database exists for exposure levels of children to iodine and its radioisotopes in various environmental exposure pathways, including food types, drinking water, and especially milk and milk products (Cohn and Gusmano 1963; FDA 1974, 1989; Soldat 1976; Stather and Greenhalgh 1983; Tubiana 1982). Information for the average daily intakes of iodine for children based on age groupings is available (Pennington et al. 1984, 1986; Trowbridge et al. 1975). Information on *in utero* exposures to iodine and its radioisotopes is available (Baši..et al. 1988; Beierwaltes et al. 1963; Dyer and Brill 1972; Etling et al. 1979; Mountford and Steele 1995; von Zallinger and Tempel 1998). There is also some information on the exposure of children to ^{131}I , and the radiation that it emits, that occurs when children are in contact with, or in the vicinity of, individuals undergoing ^{131}I treatment (Barrington et al. 1999; Jacobson et al. 1978). However, more information is needed to adequately assess the risk of children to this exposure. Also, there will be a need to develop biomarkers to assess the low level exposures of children to ^{129}I . Improvements in analytical methods have provided an ability to detect the low concentrations of ^{129}I in tissues and, thus, given us an opportunity to reliably assess low level exposures of ^{129}I in children and adults. Yet, the development of biomarkers, such as the identification of DNA mutations that would be specifically formed as a consequence of ^{129}I exposure in a cell to monitor the possible biological effects of these low level exposures, have been lacking.

Child health data needs relating to susceptibility are discussed in 3.12.2 Identification of Data Needs: Children's Susceptibility.

6. POTENTIAL FOR HUMAN EXPOSURE

Exposure Registries. No exposure registries for iodine were located. This substance is not currently one of the compounds for which a subregistry has been established in the National Exposure Registry. Iodine will be considered in the future when chemical selection is made for subregistries to be established. The information that is amassed in the National Exposure Registry facilitates the epidemiological research needed to assess adverse health outcomes that may be related to exposure to this substance.

6.8.2 Ongoing Studies

Two studies are currently underway (FEDRIP 2000) to study the interaction of iodine with differing soil components and the effect of iodine intake on the underlying mechanisms contributing to autoimmune thyroiditis. In the first study, Dr. R.L. Jones, at the Department of Natural Resources and Environmental Sciences, University of Illinois, Urbana, Illinois, is conducting a study of iodine in Illinois soils. The objective of this work is to determine the concentrations of iodine in a group of selected surface soils so that estimates of iodine concentrations can be made for major soil areas in Illinois. Analysis of soils as a function of depth and soil type will identify proportions of iodine in organic matter, and iron and aluminum fractions with the objective of identify whether differences occur between soils because of differences in soil development and genesis.

In another study, conducted by Dr. Carol L. Burek at Johns Hopkins University, Baltimore, Maryland, work is underway to determine whether increased intake of iodine contributes to an increase in the incidence of autoimmune thyroiditis (AT). The researchers intend to show that increases in iodine intake lead to an increased level of a highly iodinated form of thyroglobulin protein. It is thought that this highly iodinated form of thyroglobulin can act as an auto-immunogen and may be responsible for the T-cell mediated auto-immune response that is targeted against the thyroid gland. Using the NOD mouse model, the researchers will examine whether increased doses of iodine lead to an increase in the incidence of AT in these mice. Once this is established, the researchers will examine whether this increased incidence in AT is accompanied by an increase in the levels of highly iodinated thyroglobulin protein and increased activity of T-cells against this potential auto-immunogen.

7. ANALYTICAL METHODS

The purpose of this chapter is to describe the analytical methods that are available for detecting, measuring, and/or monitoring iodine, its radioisotopes, its metabolites, and other biomarkers of exposure and effect to iodine. The intent is not to provide an exhaustive list of analytical methods. Rather, the intention is to identify well-established methods that are used as the standard methods of analysis. Many of the analytical methods used to for environmental samples are the methods approved by federal agencies and organizations such as EPA and the National Institute for Occupational Safety and Health (NIOSH). Other methods presented in this chapter are those that are approved by a trade association such as the Association of Official Analytical Chemists (AOAC) and the American Public Health Association (APHA). Additionally, analytical methods are included that modify previously used methods to lower detection limits, and/or improve accuracy and precision.

7.1 BIOLOGICAL MATERIALS

Entry of iodine and its radioisotopes into the human body can be gained through ingestion, inhalation, or penetration through skin (IAEA 1988; NCRP 1985). The quantities of iodine within the body can be assessed through the use of bioassays that are comprised of either *in vivo* measurements and/or *in vitro* measurements. *In vivo* measurements can be obtained through techniques that directly quantitate internally-deposited iodine using, for example, thyroid or whole body counters. These *in vivo* measurement techniques are commonly used to measure body burdens of iodine radioisotopes, but cannot be used to assess the stable isotope of iodine. Instead, *in vitro* measurements provide an estimate of internally deposited iodine (both the stable and radioactive isotopes), utilizing techniques that measure iodine in body fluids, feces, or other human samples (Gautier 1983). Examples of these analytical techniques are given in NCRP Report No. 87 (1987) and are also listed in Table 7-1.

7.1.1 Internal Iodine Measurements

In vivo measurement techniques are the most direct and widely used approach for assessing the burden of iodine radioisotopes within the body. The *in vivo* measurement of these radioisotopes within the body is performed with various radiation detectors and associated electronic devices that are collectively known as *in vivo* thyroid monitors or whole body counters, depending on the body site of interest. These radiation detectors commonly utilize sodium iodide (NaI), hyperpure germanium, and organic liquid scintillation detectors to measure the gamma rays and x-rays emitted from ^{125}I and ^{131}I .

Table 7-1. Analytical Methods for Determining Iodine in Biological Samples

Sample matrix	Preparation method	Analytical method	Sample detection limit	Percent recovery	Reference
Urine	Sample purified on Dowex 1x8 resin column; dried resin fused with NaOH/KNO ₃ , dissolved in water; dry 0.5 mL aliquot on polythene sheet; irradiated, dissolved in water with iodine carrier; extracted with trioctylamine/xylene; back extracted with 1 N ammonia, precipitate as AgI ₂	INAA (γ-ray spectrometry)	0.01 µg/L	94%	Ohno 1971
Urine	Sample digested in chloric acid; arsenious acid added and then submitted for automated analysis	As-Ce catalytic spectrophotometry	between 0.01–0.06 µg per sample (0.02–0.50 mL sample volume)	96–97%	Benotti and Benotti 1963; Benotti et al. 1965
Thyroid	Powdered or fresh tissue digested with H ₂ SO ₄ ; iodide converted to Al ₂ I ₆ , neutron irradiated; iodine precipitated with Pd	Neutron activation plus mass spectrometry	0.11–2.17 mg/g (range of measured values)	No data	Ballad et al. 1976, Boulos et al. 1973, Oliver et al. 1982
Adipose tissue	Sample placed into polyethylene vials and neutron irradiated	INAA (γ-ray spectrometry)	1.4–8.6 µg/g	No data	EPA 1986

Table 7-1. Analytical Methods for Determining Iodine in Environmental Samples (*continued*)

Sample matrix	Preparation method	Analytical method	Sample detection limit	Percent recovery	Reference
Non-thyroid tissues	Tissue samples lyophilized, sealed in polyethylene film, and irradiated with epithermal neutrons using a boron nitride shield	INAA (γ -ray spectrometry)	9.4–2,880 ng/g (range of measured values)	No data	Hou et al. 1997b
Tissues	Aqueous NaOH and Na ₂ S ₂ O ₅ added to tissue homogenates; ashed; residue dissolved in water and then injected into an HPLC for the separation of components on a two-column system followed by quantitation of iodine by UV	HPLC with UV detection	0.07–1,060 μ g/g (range of measured values)	87–97%	Andersson and Forsman 1997
Plasma (protein bound)	Protein precipitated by Somogyi's zinc sulfate reagent, digested in CrO ₃ , purified by distillation	As-Ce catalytic spectrophotometry	0.01 μ g/mL	75–100% (0.01–0.05 μ g/mL)	Barker 1948
Feces	Dried; pulverized; digested in HNO ₃ /HF; treated with HCl/HNO ₃	ICP-AES	0.1 μ g/mL	88–90%	Que Hee and Boyle 1988
Feces	Dried; pulverized; digested in chloric acid; arsenious acid added and then submitted for automated analysis	As-Ce catalytic spectrophotometry	between 0.01–0.06 μ g per sample (20–30 mg sample size)	97–101%	Benotti and Benotti 1963, Benotti et al. 1965

Table 7-1. Analytical Methods for Determining Iodine in Environmental Samples (*continued*)

Sample matrix	Preparation method	Analytical method	Sample detection limit	Percent recovery	Reference
Milk, serum	Sample is mixed with acetonitrile (1:2), centrifuged; supernatant dried; dissolved in acetonitrile/water and a 1 mL aliquot derivatized with 2-iodosobenzoate in phosphate buffer containing 2,6-dimethylphenol	HPLC with UV detection	0.5 µg/L	97.6–102.4%	Verma et al. 1992
Milk, yogurt, cream	Sample incubated in two parts (v:v) methanol; filtered; 4 mL filtrate passed through Sep-Pak C ₁₈ cartridge; final 2 mL of eluate filtered; 100 µL aliquot analyzed by HPLC	HPLC with amperometric detection	25 µg/L	92–114%	Chadha and Lawrence 1990
Bread	Bread is dried; ground; treated with 2N Na ₂ CO ₃ plus 1% KClO ₃ ; dried; incinerated; dissolved; analyzed by the ceric arsenite reaction	As-Ce catalytic spectrophotometry	0.05 µg/g	No data	Sachs et al. 1972

As-Ce catalytic spectrophotometry = arsenious-ceric ion catalytic spectrophotometry; HPLC = high performance liquid chromatography; ICP-AES = inductively coupled plasma-atomic emission spectrometry; INAA = instrument neutron activated analysis; UV = ultraviolet/visible

7. ANALYTICAL METHODS

The gamma-ray and x-ray photopeaks that are commonly used in the detection and quantitation of these iodine radioisotopes are the 28 keV (0.0665 photons/transition) gamma-ray and/or the $K_{\alpha 1}$ (27.5 keV, 0.739 photons/transition), $K_{\alpha 2}$ (27.2 keV, 0.397 photons/transition), $K_{\beta 1}$ (31.0 keV, 0.140 photons/transition), and $K_{\beta 2}$ (31.7 keV, 0.043 photons/transition) x-rays for ^{125}I , and the 364 keV gamma-ray for ^{131}I (Jönsson and Mattsson 1998; Landon et al. 1980; Palmer et al. 1976). The third iodine radioisotope that is commonly encountered in the environment, ^{129}I , is difficult to quantitate using *in vivo* monitoring and scanning techniques due to its low specific activity (0.17 mCi/g), low abundance in the environment, and low energy β^- (150 keV) and gamma (40 keV) radiation (NCRP 1983).

Because approximately 20–30% of the iodine that enters the body is taken up by the thyroid gland, *in vivo* thyroid monitoring is preferably and reliably used for assessing ^{125}I and ^{131}I burdens in exposed individuals (Bartolini et al. 1988; Bhat et al. 1973; Blum and Liuzzi 1967; Jacobson et al. 1978; Jönsson and Mattsson 1998; Landon et al. 1980; Mandó and Poggi 1988; Nishiyama et al. 1980; Palmer et al. 1976; Plato et al. 1976; Pomroy 1979). As such, *in vivo* thyroid scanning techniques are routinely used to assess thyroid burdens of ^{125}I and ^{131}I in individuals with occupational exposures to these radioisotopes; for example, medical personnel, laboratory technicians, nuclear medicine staff, radiochemists, and personnel involved with nuclear fuel processing. The relatively low attenuation of the gamma rays emitted from ^{131}I by most tissues allows for whole body and thyroid scanning techniques to be utilized in quantitating this iodine radioisotope within an individual (Berg et al. 1987; Nishiyama et al. 1980). Attenuation of lower energy gamma-ray and x-ray emissions for ^{125}I through tissues is greater than what is observed for the higher energy ^{131}I gamma-ray. However, the position and close proximity of the thyroid at the base and surface of the neck helps to minimize the effect that attenuation can have on the detection and quantitation of ^{125}I in the thyroid, as compared to deeper tissues.

Many configurations of the thyroid and whole body counter and scanning methods have been utilized for monitoring and quantitating thyroid iodine radioisotope burdens, ranging from unshielded single-crystal field detectors to shielded, multi-detector scanning detectors (IAEA 1962, 1970, 1972, 1976, 1985; NCRP 1987; Palmer et al. 1976; Plato et al. 1976). The minimum detectable activity of these devices is typically around 30–300 pCi for thyroid monitoring and approximately 2 nCi for whole body scanners (Nishiyama et al. 1980; Palmer et al. 1976; Plato et al. 1976). Where appropriate, shielding of the room that houses the thyroid or whole body counter can be used to increase the detection sensitivity of the equipment by minimizing background radiation. To further insure that internalized iodine radioisotopes are accurately measured, removal of external contamination with radioactive iodine or other gamma-emitting radioisotopes on the clothing or skin of the individual to be scanned is recommended (Palmer et al. 1976). Also, *in vitro* measurements of iodine (see Section 7.1.2) can be used in conjunction with *in vivo* thyroid monitoring when assessing individuals working with iodine radioisotopes, especially in the assessment of individuals who have experienced accidental or routine exposures to iodine radioisotopes (Bhat et al. 1973; Nishiyama et al. 1980).

7. ANALYTICAL METHODS

Calibration of thyroid and whole body counts is achieved through the use of tissue-equivalent phantoms. These phantoms are constructed to mimic the shape and density of the anatomical structure using tissue equivalent materials such as water-filled canisters or masonite (Bhat et al. 1973; Jönsson and Mattsson 1998; Landon et al. 1980; Nishiyama et al. 1980; Palmer et al. 1976; Plato et al. 1976). An example of a neck phantom is a polyethylene or Lucite cylindrical container filled with water to approximate the dimensions and density of the neck (Jönsson and Mattsson 1998; Landon et al. 1980; Palmer et al. 1976; Plato et al. 1976). Radioiodine standards are measured either as point sources along the phantom or, more typically, dissolved within two water-filled polyethylene or glass tubes (1–2.5 cm in diameter by 5–7 cm in length) that are set at an appropriate distance apart to approximate the positioning of the two lobes of the thyroid glands in the base of the neck. The dimensions of the Lucite and polyethylene neck phantoms are varied to more accurately mimic the actual ranges of adult and children's neck sizes (Palmer et al. 1976; Plato et al. 1976; Pomroy 1979). Other types of modified thyroid-neck phantom models and whole body phantoms have been used to calibrate radioiodine measurements as well (Nishiyama et al. 1980). Comparisons of the actual counting rates obtained from the phantom and the known activity of the radioiodine standards are used to determine the efficiency of the counting technique and, thus, provide the basis for calibration.

Assessment of short- and long-term retention of iodine radioisotopes must take into account the turnover rate for radioiodine within the human body. For ^{125}I , the mean effective half-life within the body is 37–39 days (Bartolini et al. 1988; Landon et al. 1980); for ^{131}I , the mean effective half-life is 5–7.6 days (Bhat et al. 1973). These values are much less than the actual biological half-life of iodine (^{127}I) in the body of 96–138 days (Bartolini et al. 1988; Landon et al. 1980), due to the relatively short physical half-lives of these radioisotopes. For acute and chronic exposures to radioiodine, the estimates of radioiodine retention are best calculated from results of multiple thyroid or whole-body measurements. This is because of individual variability in thyroid uptake rates, excretion rates, and uncertainties in determining uptake of radioiodine through inhalation, ingestion, and the skin (Landon et al. 1980; Mandó and Poggi 1988). However, direct comparisons between laboratories of body burdens and clearance rates for specific radioisotopes can be complicated by the differing whole body measurement techniques, calibration methods, and methods used to account for normal background radiation counts that are utilized within the different laboratories.

7.1.2 External Measurements

In vitro analyses of iodine are routinely performed in situations where *in vivo* analyses cannot be obtained or in support of an *in vivo* monitoring program. Urine is the preferred sample for *in vitro* analyses of iodine, although other sample types, such as feces, tissue, blood, serum, and hair, also can be used on a more limited basis with good detection sensitivities that are typically on the order of <1 µg per sample (NAS 1974). Urine provides for an analysis of soluble iodine, fecal analysis can be used to assess the

7. ANALYTICAL METHODS

fraction of ingested iodine not absorbed by the gut, and tissue is used to assess whole or regional body burdens of iodine (NCRP 1987).

The *in vitro* analysis of the stable isotope of iodine, ^{127}I , in commonly acquired human samples (e.g., urine, tissue, feces) is performed by a number of methods that have the selectivity and/or sensitivity to measure iodine in biological matrices (Table 7-1). These methods include arsenious-ceric ion catalytic spectrophotometry, instrumental neutron activation analysis (INAA), inductively coupled plasma atomic emission spectrometry (ICP-AES), and high performance liquid chromatography/ultra-violet-visible detection techniques (Andersson and Forsman 1997; Barker 1948; Benotti and Benotti 1963; Benotti et al. 1965; Cornelis et al. 1975; EPA 1986; Hou et al. 1997b; Ohno 1971; Que Hee and Boyle 1988). The INAA and ICP-AES methods offer the greatest sensitivity for the detection of iodine in human samples (Table 7-1). An example of an application of INAA to the measurement of iodine in urine involves a prepurification of the urine sample to remove interfering ions, such as bromide, upon activation by neutrons (photopeaks are 0.45 MeV for ^{128}I and 0.55 MeV for ^{82}Br). The urine sample is first passed over Dowex 1X8 anion exchange resin, and then followed by the fusion of the washed and dried resin with NaOH/HNO₃. The fusion residue is dissolved in water with a 0.5 mL aliquot transferred to a polyethylene sheet and dried. The sample is then irradiated with neutrons, dissolved in a solution containing a iodide carrier, extracted with trioctylamine/xylene, back extracted first with 1 M sodium nitrate to remove bromine and then back extracted into 1 N ammonia. From here, the iodine is precipitated as silver iodide, filtered, and analyzed by gamma spectrometry (Ohno 1971).

For the *in vitro* analysis of the iodine radioisotopes, ^{125}I and ^{131}I , in human samples, there are a number of the analytical methods that can measure these radioisotopes directly in the samples without the requirement for an extensive sample preparation procedure (Table 7-2), as has been demonstrated for other radioisotopes (Gautier 1983). In the radiochemical analysis of radioiodine in urine, a 24-hour urine collection (approximately 2 L) is obtained followed by the transfer of a 1 L aliquot to a Marinelli beaker for counting in a gamma ray spectrometer. This simple procedure offers high recoveries of 98% and the minimum detection sensitivity 100 pCi/L that is required to evaluate individuals for exposures to ^{125}I and ^{131}I . Similar methods can also be used for the analysis of these iodine radioisotopes in tissues, feces, blood, milk, and food (AOAC 1984; Baratta and Easterly 1989; Ekman et al. 1967; Gautier 1983).

Table 7-2. Analytical Methods for Determining Radioiodine in Biological Samples

Sample matrix	Preparation method	Analytical method	Sample detection limit	Percent recovery	Reference
Urine	Sample transferred to Marinelli beaker and counted	γ -spectrometry with NaI detector	100 pCi/L (^{131}I)	98%	Gautier 1983
Thyroid	^{129}I counted directly in thyroid tissue	X-ray spectrometry with HP Ge detector	0.04 pCi/g (^{129}I)	No data	Van Middlesworth 1993
Thyroid	Powdered or fresh tissue digested with H_2SO_4 ; iodide converted to Al_2I_6 ; neutron irradiated, and iodine precipitated with Pd	Neutron activation and mass spectrometry	45 pg/g (^{129}I)	No data	Boulos et al. 1973, Oliver et al. 1982
Thyroid and other tissues	Tissue sample were lyophilized and ground; pyrolyzed in O_2/N_2 stream; iodine absorbed onto charcoal; iodine liberated from charcoal by heating; isolated by distillation on cooled glass and then neutron irradiated	INAA with Ge(Li) γ -spectrometry	18–74 fCi/g (^{129}I)	85% (thyroid) 50–60% (other tissues)	Handl et al. 1990
Saliva	Saliva samples obtained and directly counted	Scintillation counter	1.26–36.5 nCi/mL (range of measured values) (^{125}I)	No data	Nishizawa et al. 1985
Feces	Sample directly counted in detector	γ -spectrometry with NaI detector	0.14 nCi/L (^{131}I)	No data	Lipsztein et al. 1991
Cow's milk	Sample (50–100 mL) directly counted in iron shielded gamma spectrometer	γ -spectrometry with NaI detector	4–100 pCi/L (range of measured values) (^{131}I)	No data	Ekman et al. 1967
Cow's milk	Conversion of iodine to iodide; concentrated on anion exchange resin; extracted through CCl_4 , water, then toluene	Liquid scintillation counter	0.3 pCi/L (^{129}I)	58% raw milk, 80% pasteurized milk; with 30 mg iodine carrier	Gabay et al. 1974
Food	Food samples directly counted in gamma-ray spectrometer	γ -spectrometry with NaI or Ge(Li) detector	0.05 pCi/g (^{131}I)	No data	Cunningham et al. 1989, 1994

HP = high purity; INAA = instrument neutron activation analysis

7. ANALYTICAL METHODS

For the quantitation of ^{129}I , more sensitive methods are required than those described above for ^{125}I and ^{131}I (Table 7-2). One approach utilizes the transmutation of the ^{129}I isotope to another isotope that can be quantitated using mass spectrometric techniques. For example, neutron activation of iodine extracted from thyroid tissues, followed by noble gas mass spectrometry analysis of the resulting xenon isotopes, has been used to measure ^{129}I and the $^{129}\text{I}/^{127}\text{I}$ ratio in these tissues (Boulos et al. 1973). This procedure uses the measurement of ^{126}Xe , ^{128}Xe , and ^{130}Xe isotopes that are formed in the decay of the iodine isotopes, ^{126}I , ^{128}I , and ^{130}I , to determine the amount ^{129}I and ^{127}I in tissue extracts (see below).

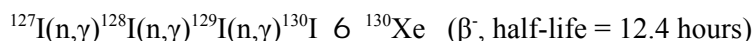
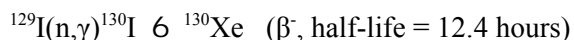
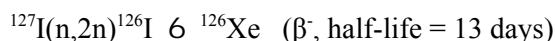
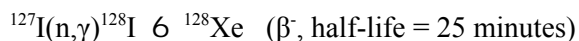

Both the ratio of $^{130}\text{Xe}/^{128}\text{Xe}$ and $^{130}\text{Xe}/^{126}\text{Xe}$ will be proportional to the ratio of $^{129}\text{I}/^{127}\text{I}$ in the extract. The method is able to provide a detection sensitivity that is sufficient to measure ^{129}I as low as 45 pg/g tissue and/or a ratio of $^{129}\text{I}/^{127}\text{I}$ of 10^{-10} . In those cases where INAA methods cannot be applied due to a large sample set size, availability of an appropriate reactor, the short half-life of the isotope of interest (e.g., ^{130}I), or the cost of activation, there are other techniques available to enhance the detection sensitivity for the ^{129}I isotope (Gabay et al. 1974). For example, preconcentration of ^{129}I using anion exchange methods in addition to purifying the sample of interfering materials has been used successfully to analyze samples containing low amounts of ^{129}I (Gabay et al. 1974, Table 7-2). Also, inductively coupled plasma-mass spectrometry (ICP-MS) methods have been used to quantitate iodine in biological samples using differing sample preparation methods, including Schöniger combustion and extraction methods, providing limits of detection (50 and 0.3 ng/g, respectively) that are appropriate for performing trace analysis of iodine in a large number of environmental and biological samples (Gélinas et al. 1998).

Accuracy of *in vivo* and *in vitro* measurements of iodine and its radioisotopes is determined through the use of standard, certified solutions or radioactive sources with known concentrations or activities of iodine. National Institute of Standards and Technology (NIST) traceable standards for ^{125}I and ^{127}I can be obtained through a number of commercial sources. The primary source of certified iodine radioisotope standards is the NIST. Standard reference materials (SRM) for ^{129}I (SRM 4401LZ, 30MBq [0.8 mCi]) and ^{131}I (SRM 4949C, 17 kBq [0.45 μCi]) are available from NIST. SRMs are also available for ^{127}I measurements, including SRM 909 (serum), SRM 1486 (bone meal), SRM 1548 (mixed diet), SRM 1549 (nonfat milk powder), SRM 1846 (infant formula), and SRM 2383 (baby food).

7.2 ENVIRONMENTAL SAMPLES

There are two common approaches for measuring iodine radioisotopes in the environment. Iodine radioisotopes can either be measured directly in the field (*in situ*) using portable survey instruments or samples can be procured from the field and returned to the laboratory for quantitation of iodine. However, quantitation of the stable iodine isotope in environmental samples is generally conducted in the laboratory.

7.2.1 Field Measurements of Iodine

In situ measurement techniques are extremely useful for the rapid characterization of radionuclide contamination in the environment, such as soils, sediments, and vegetation, or when monitoring personnel for exposure to radionuclides. The measurement of gamma-ray-emitting radionuclides in the environment is conducted with portable survey instruments such as Gieger-Mueller detectors, sodium iodide scintillation detectors, and gamma-ray spectrometers. However, the use of gamma-spectrometers in field survey equipment is preferred for measuring ^{131}I in the field because of its selectivity and sensitivity (EML 1997). The energy and penetrance of the gamma-rays that are emitted during the decay of ^{131}I provides an advantage for assessing the level of iodine both on and below the surface using portable field survey instruments such as the gamma-ray spectrometer (EML 1997). These gamma-ray spectrometers are equipped with a high purity germanium detector that is able to resolve the 364 keV gamma-ray emitted from ^{131}I from the gamma-rays emitted from other radionuclides; for example, ^{40}K (NRC 1997). The concentration and distribution of ^{131}I that have been detected in the field will need to be determined by laboratory-based analyses of soil samples procured from the survey area.

7.2.2 Laboratory Analysis of Environmental Samples

Analytical methods for quantifying iodine and iodine radioisotopes in environmental samples (e.g., air, water, soil, biota, and food) are summarized in Tables 7-3 (^{127}I) and 7-4 (^{125}I , ^{129}I , and ^{131}I). The methods that are commonly used in the analysis of ^{127}I are based on instrument-based analytical techniques, such as spectrophotometry, electrochemistry, INAA, mass spectrometry (MS), and some colorimetric techniques. The analysis of ^{125}I , ^{129}I , and ^{131}I can be determined either as total mass or total activity, depending on the analytical technique that is used. Typically, radiochemical methods of analysis employing gamma-ray spectrometry and β - γ coincidence scintillation techniques are used to quantitate ^{125}I and ^{131}I in environmental samples. However, more sensitive analytical techniques, such as INAA and MS, are typically required to analyze ^{129}I in environmental samples (Lindstrom et al. 1991; Stephenson and Motycka 1994). Neutron activation and mass spectrometric methods are especially useful, since the amount of ^{129}I in a sample is often expressed in proportion to amount of ^{127}I in the same sample

Table 7-3. Analytical Methods for Determining Iodine in Environmental Samples

Sample matrix	Preparation method	Analytical method	Sample detection limit	Percent recovery	Reference
Aerosol (ambient)	Aerosols collected using an Anderson cascade impactor; iodine separated from filters by ignition and adsorbed onto charcoal; extracted from charcoal using NaOH solution; acidified; extracted into CCl ₄ as iodine; back extracted into dilute H ₂ SO ₄ and precipitated as PdI ₂ , then neutron irradiated	INAA with Ge γ -ray detector	1.68–4.23 ng/m ³ (range of measured values)	No data	Tsukada et al. 1991
Air (ambient)	A known volume of air is passed through a multistage filter assembly; filters extracted in a heated NaOH/Na ₂ SO ₃ solution containing ¹²⁹ I ⁻ as an internal standard; filtered; acidified; iodide precipitated as AgI; filtered; precipitate dissolved in aqueous NH ₃ and analyzed	IDMS	0.02–0.024 ng/m ³ (for an average air volume of 70 m ³)	97–99%	Gäbler and Heumann 1993
Air (occupational)	A known volume of air is drawn into a glass tube containing 150 mg of charcoal; iodine extracted into 0.01 M Na ₂ CO ₃ using an ultrasonic bath; filtered; injected into ion chromatograph	Ion chromatography	0.45 μ g/mL	101%	Kim et al. 1981
Water and waste water (EPA Method 345.1)	CaO added to sample; filtered; sodium acetate/acetic acid then bromine water added; excess bromine with sodium formate removed; KI and H ₂ SO ₄ , titrate added with phenylarsine oxide or sodium thiosulfate using starch indicator	Colorimetric	2–20 mg/L (range of measured values)	80–97% (4.1–21.6 mg/L)	EPA 1983
Water	Sample acidified with HCl; oxidized with H ₂ O ₂ or KMnO ₄ ; treated with NaSO ₃ to remove excess oxidant; titrated with KIO ₃	Spectrophotometry	25 μ g/L–6.35 mg/L	-100% at 0.13–6.35 mg/L	Pesavento and Profumo 1985

Table 7-3. Analytical Methods for Determining Iodine in Environmental Samples (continued)

Sample matrix	Preparation method	Analytical method	Sample detection limit	Percent recovery	Reference
Water (iodide+iodate)	Ascorbic acid (2%) added to sample; 5 minute stand; reacted with acidified NaNO ₂ ; evolved iodine extracted into xylene and analyzed at the emission intensity for iodine of 178.28 nm	ICP-AES	1.6 µg/L	95–103%	Miyazaki and Bansho 1987
Water (Iodide)	Sample reacted with acidified NaNO ₂ ; evolved iodine extracted into xylene; back extracted into 0.5 % aqueous ascorbic acid and analyzed at the emission intensity for iodine of 178.28 nm	ICP-AES	1.6 µg/L	97–102%	Miyazaki and Bansho 1987
Water (iodine species)	Samples divided and spiked with ¹²⁹ I ⁻ or ¹²⁹ IO ₃ ⁻ ; oxidized with UV or HNO ₃ /H ₂ O ₂ (total I), or concentrated/purified on an anion exchange column (I ⁻ , IO ₃ ⁻ ; anionic organoiodine); samples are then reduced with Na ₂ SO ₃ and precipitated as AgI	IDMS	0.5 µg/L (I ⁻) 0.1 µg/L (IO ₃ ⁻) 0.2 µg/L (anionic organoiodine) 0.05 µg/L (total iodine)	No data	Reifenhäuser and Heumann 1990
Drinking water	Sample separated on a Dionex AS12 analytical HPLC column; the eluted iodate reacted with acidified bromide in post-column reaction to form tribromide that is detected at 267 nm	HPLC with UV detection	0.05 µg/L	110–111% (at 0.5–2.0 µg/L)	Weinberg and Yamada 1997
Tap water	Sample acidified to 0.1 mN nitric acid + Hg ⁺² (as Hg(NO ₃) ₂) added to 300 µg/L; 20 µL aliquot injected into atomizer	Electrothermal atomic absorption spectrometry	3.0 µg/L	94.8–104.4% (at 5–20 µg/L)	Bermejo-Barrera et al. 1994
Fresh water (total iodine)	Iodine-iodide is directly measured in water sample	As-Ce catalytic spectrophotometry	0.1 µg/L	100%	Jones et al. 1982
Fresh water (iodate)	Iodine-iodide is removed from sample through extraction into chloroform as ion-pair with tetraphenylarsonium cation	As-Ce catalytic spectrophotometry	0.1 µg/L	-100% (at 2 µg/L iodate)	Jones et al. 1982

Table 7-3. Analytical Methods for Determining Iodine in Environmental Samples (continued)

Sample matrix	Preparation method	Analytical method	Sample detection limit	Percent recovery	Reference
Fresh water	One liter sample is acidified with nitric acid; 5 mL sample is irradiated, filtered, and counted	INAA using Ge(Li) γ -spectrometry	0.20 $\mu\text{g/L}$	No data	Salbu et al. 1975
Drinking water (total iodine)	K_2CO_3 added to sample; centrifuged to remove precipitated alkaline earth metals; iodine measured by addition of nitric acid, NaCl, $\text{NH}_4\text{Fe}(\text{SO}_4)_2$ and KSCN	Spectrophotometry	0.2 $\mu\text{g/L}$	90–108%	Moxon 1984
Drinking water (free iodide)	K_2CO_3 added to sample; centrifuged to remove precipitated alkaline earth metals; iodide measured by addition of reduced amounts of nitric acid, NaCl, $\text{NH}_4\text{Fe}(\text{SO}_4)_2$, and KSCN	Spectrophotometry	0.4 $\mu\text{g/L}$	89–109%	Moxon 1984
Fresh and sea waters	Samples directly injected onto a weakly anionic ion-exchange column for iodide analysis; iodate measured through reduction to iodide by ascorbic acid	HPLC with ion-selective electrode detector	2 $\mu\text{g/L}$	No data	Butler and Gershey 1984
Sea water and river water	Sample (neat or diluted) were treated with HClO_4 , acetone, and KMnO_4 ; KMnO_4 reduced with oxalic acid, then treated with NaS_2O_3 /chromic acid followed by extraction into benzene containing p-dichlorobenzene as an internal standard	GC-ECD	0.1 $\mu\text{g/L}$	No data	Maros et al. 1989
Sea water	Sample acidified with acetic acid; bromine vapor dissolved into sample; excess removed through volume reduction; titrated with iodate	Amperometric method	5 $\mu\text{g/L}$	98–112%	Barkley and Thompson 1960
Sea water (iodine)	Iodide in sample precipitated with AgNO_3 ; precipitate dissolved in acetic acid saturated with Br_2 ; filtered; filtrate reduced in volume; then reacted with starch solution and CdI_2	Spectrophotometry	0.025 $\mu\text{g/L}$	99% (at 10 $\mu\text{g/L}$ iodine)	Tsunogai 1971

DRAFT FOR PUBLIC COMMENT

Table 7-3. Analytical Methods for Determining Iodine in Environmental Samples (continued)

Sample matrix	Preparation method	Analytical method	Sample detection limit	Percent recovery	Reference
Sea water (iodate)	Iodide in sample precipitated with AgNO ₃ ; iodate in filtrate is reduced to iodide with NaSO ₃ /H ₂ SO ₄ , acetic acid saturated with Br ₂ added; filtered; filtrate reduced in volume; reacted with starch solution and CdI ₂	Spectrophotometry	0.025 µg/L	No data	Tsunogai 1971
Sea water	Sample filtered and concentrated/purified on an AG1X4 anion exchange column; I ⁻ , IO ₃ ⁻ , and organic iodine were isolated preferentially isolated; neutron irradiated; iodide carrier added; treated with NaNO ₂ in HNO ₃ ; extracted into CCl ₄ ; back extracted into a KHSO ₃ solution and counted	INAA using Ge(Li) γ-spectrometry	0.2 µg/L	99.5% (post-irradiation recovery)	Hou et al. 1999
Sea water and brackish water*	Sample treated with CaO; iodide oxidized with Br ₂ in acetate buffer; excess Br ₂ removed with sodium formate; iodate converted to iodine and titrated with NaS ₂ O ₃ using starch indicator	Spectrophotometry	0.2–2,000 mg/L (range of measured values)	93.6–96.7% (at 12.1–1,375 mg/L)	ASTM 1995
Sea water and brackish water	Sample is acidified with HCl; iodide converted to iodine with KNO ₂ and extracted into CCl ₄ ; absorbance of iodine-CCl ₄ measured at 517 nm	Spectrophotometry	0.2–2,000 mg/L (range of measured values)	100–108% (at 12.1–1,375 mg/L)	ASTM 1995
Sea water and brackish water	500 µL of sample diluted to 50 ml with water plus NaNO ₂ solution; measured potential; quantitated using standard additions	Iodide selective electrode	1–2,000 mg/L (range of measured values)	102–109% (at 12.1–1,375 mg/L)	ASTM 1995
Brine and thermal waters	Sample treated with 14 N H ₂ SO ₄ plus 3 M H ₂ O ₂ ; extracted with CCl ₄ ; back into 0.1 mM NaS ₂ O ₃ ; then iodine/methylene blue ion pair extracted into 1,2-dichloro-ethane	Spectrophotometry	10 µg/L	68% (at 0.4 mM iodine)	Koh et al. 1988

Table 7-3. Analytical Methods for Determining Iodine in Environmental Samples (continued)

Sample matrix	Preparation method	Analytical method	Sample detection limit	Percent recovery	Reference
Groundwater	Metals chelated with EDTA and iodate is directly measured; iodide can be indirectly measured through conversion to iodate by treatment with chlorine water	Single-sweep polarography	0.005 µg/L	No data	Whitnack 1975
Soil	Sample dried; sieved (7 mm diameter), ground; sieved (2 mm diameter); extracted with 2 N NaOH; arsenious acid added then submitted for automated analysis	As-Ce catalytic spectrophotometry	0.5 µg/g	No data	Whitehead 1979
Soil, sediments, rock	Sample dried and pulverized; mixed with V ₂ O ₅ and pyrohydrolyzed; evolved iodine dissolved in NaOH solution digested with acid	As-Ce catalytic spectrophotometry	0.05 µg/g (0.5 g sample size)	75–90%	Rae and Malik 1996
Coal and fly ash	<250 mg samples dried; irradiated with neutrons and then counted	INAA using Ge(Li) γ-spectrometry	0.6–1.8 µg/g (range of measured values)	No data	Germani et al. 1980
Vegetation	Sample prepared by microwave digestion using HNO ₃ /H ₂ O ₂ ; treated with Na ₂ S ₂ O ₃ or ascorbic acid solution to convert iodate to iodide	ICP-MS	100 pg/g	96–104%	Kerl et al. 1996

As-Ce catalytic spectrophotometry = arsenious-ceric ion catalytic spectrophotometry; GC-ECD = gas chromatography-electron capture detection; HPLC = high performance liquid chromatography; ICP-AES = inductively coupled plasma-atomic emission spectrometry; ICP-MS = inductively coupled plasma-mass spectrometry; IDMS = isotope dilution mass spectrometry; INAA = instrumental neutron activation analysis; UV detection = ultraviolet/visible detection

Table 7-4. Analytical Methods for Determining Radioiodine in Environmental Samples

Sample matrix	Preparation method	Analytical method	Sample detection limit	Percent recovery	Reference
Air (occupational)	Air samples drawn into a regulated, constant-flow air sampler for personnel monitoring at a flow rate of 2 L/minute for several periods of 2–7 minutes; air-borne iodine was trapped in a charcoal sampling tube, then counted	Scintillation counter with NaI detector	2 fCi/mL (¹³¹ I)	No data	Luckett and Stotler 1980
Aerosols (occupational)	Air drawn through a 25 mm cellulose nitrate/acetate filter at a constant flow rate of 2 L/minute; filter counted	Scintillation counter with NaI detector	5 fCi/mL (¹²⁵ I) 0.3 fCi/mL (¹³¹ I)	No data	Eadie et al. 1980
Aerosols (ambient)	Aerosols were collected using an Anderson cascade impactor; filters removed from impactor and then neutron irradiated	INAA with Ge γ-ray detector	0.24–0.26 aCi/m ³ (range of measured values) (¹²⁹ I)	No data	Tsukada et al. 1991
Water	Add iodide carrier and NaOCl to 4 L sample; stir; add NH ₂ OH·HCl and NaHSO ₃ ; stir; filter; extract through anion exchange resin; elute iodide with NaOCl; treat with HNO ₃ ; extract with toluene and aqueous NH ₂ OH·HCl, back extract with aqueous NaHSO ₃ ; precipitate iodide as CuI	γ-spectrometry with Ge detector	<1 pCi/L (¹³¹ I)	No data	ASTM 1994
Drinking water	Iodate carrier added to sample and iodate reduced to iodide with NaSO ₃ ; iodide precipitated with AgNO ₃ ; AgI dissolved and purified with Zn powder and sulfuric acid; iodide reprecipitated as PdI ₂	β-γ coincidence scintillation system	0.1 pCi/L (¹³¹ I)	No data	EPA 1976, 1980

DRAFT FOR PUBLIC COMMENT

Table 7-4. Analytical Methods for Determining Radioiodine in Environmental Samples (continued)

Sample matrix	Preparation method	Analytical method	Sample detection limit	Percent recovery	Reference
Drinking water	Iodate carrier and tartaric acid are added to sample, HNO ₃ added and sample distilled into NaOH solution; distillate acidified with H ₂ SO ₄ and oxidized with NaNO ₂ ; extracted into CCl ₄ ; back extracted into NaHSO ₃ ; and iodide reprecipitated as PdI ₂	β-γ coincidence scintillation system	0.1 pCi/L (¹³¹ I)	No data	Krieger 1976
Fresh water	Conversion of iodine to iodide; concentrated on anion exchange resin; extracted with CCl ₄ , water, then toluene	Liquid scintillation counter	0.3 pCi/L (¹²⁹ I)	74% with 30 mg iodine carrier	Gabay et al. 1974
Fresh water	Iodide carrier added to sample; treated with HCl and sodium metabisulfite; iodide concentrated on a strong anion exchange resin with iodine carrier; ¹²⁵ I directly detected on resin	γ-spectrometry with Ge(Li) detector and x-ray fluorescence for yield correction	30 pCi/L (¹²⁵ I)	No data	Howe and Bowlt 1991
River water	Sample directly analyzed or concentrated on an anion exchange resin; eluted with nitric acid; analyzed, using indium as an internal standard	ICP-MS	0.5 pCi/L (¹²⁹ I)	No data	Beals and Hayes 1995; Beals et al. 1992

Table 7-4. Analytical Methods for Determining Radioiodine in Environmental Samples (continued)

Sample matrix	Preparation method	Analytical method	Sample detection limit	Percent recovery	Reference
Aqueous sample	Sample concentrated on a Dowex 1x8 anion exchange resin; resin pyrolyzed; iodine adsorbed onto activated charcoal; iodine removed by heating charcoal; neutron irradiated; iodine carrier added; iodine extracted into xylene; iodide precipitated with silver	INAA with Ge(Li) detector	3.8 fCi/L (¹²⁹ I)	50%	Anderson 1978
Water	Iodide carrier was added to samples; treated with sodium hypochlorite, purified; reduced to isolate iodine and iodine precipitated as AgI; AgI was mixed with either a niobium or ultrapure silver metal binder and dried onto stainless-steel sample holders for analysis	AMS	<0.3 pg/g (¹²⁹ I)	No data	DOE 1994; Elmore and Phillips 1987; Elmore et al. 1980
Water and waste water	Direct count of sample	γ-spectrometry with Ge/Li detector	<2 pCi/L (¹³¹ I)	92–100% at 2–94 pCi/L	ASTM 1998
Treated sewage effluent	Sample directly counted in 3.5 L aluminum beaker	γ-spectrometry with NaI(Tl) detector	No data (¹³¹ I)	No data	Sodd et al. 1975
Treated sewage (influent/effluent)	Sample counted directly or first concentrated on anion exchange column after reduction of iodine to iodide in sample; eluted with acid then counted	γ-spectrometry with NaI(Tl) detector	180 pCi/L (direct count), 0.35 pCi/L (concentrated) (¹³¹ I)	No data	Prichard et al. 1981

DRAFT FOR PUBLIC COMMENT

Table 7-4. Analytical Methods for Determining Radioiodine in Environmental Samples (continued)

Sample matrix	Preparation method	Analytical method	Sample detection limit	Percent recovery	Reference
Soil, sediments, vegetation	Sample dried; iodine extracted through combustion of soil in oxygen; iodine trapped onto charcoal after passage over hydrated manganese dioxide (HMD); neutron irradiated; Br removed through passage over HMD	INAA with Ge(Li) detector	5 aCi/g (^{129}I)	No data	Lindstrom et al. 1991; Lutz et al. 1984
Vegetables	Sample lyophilized; Na_2CO_3 , NaCl, and ^{131}I (internal standard) added; dried and ashed; treated with MnO_2 and evolved iodine trapped in 0.1% NaHSO_3 containing iodide carrier	ICP-MS	1.4 pg/g (0.24 fCi/g)(^{129}I)	88%	Cox et al. 1992
Plants	Plant samples were lyophilized and ground; ^{125}I added as internal standard; sample was pyrolyzed in O_2/N_2 stream; iodine absorbed onto charcoal; iodine liberated from charcoal by heating; isolated by distillation on cooled glass and then neutron irradiated	INAA with Ge(Li) γ -spectrometry	18–74 fCi/g (^{129}I)	50–60%	Handl et al. 1990

AMS = accelerator mass spectrometry; ICP-MS = inductively coupled plasma-mass spectrometry; INAA = instrumental neutron activation analysis

7. ANALYTICAL METHODS

(Muramatsu et al. 1985). For example, the mass spectrometry techniques that are utilized to measure iodine in samples, such as neutron activation-noble gas mass spectrometry or accelerator mass spectrometry, provide the ability to resolve the ^{127}I and ^{129}I isotopes in the quantitation step and also have the required sensitivity range to measure ratios of 10^{-10} – 10^{-7} for $^{129}\text{I}/^{127}\text{I}$ in most environmental and biological samples (Gramlich and Murphy 1989; Schmidt et al. 1998).

The analysis of ^{127}I in air is based on the quantitation of this isotope of iodine in its gaseous form (I_2) or within aerosols or particulates, either separately or combined (Dams et al. 1970; Gäbler and Heumann 1993; Kim et al. 1981; Sheridan and Zoller 1989; Tsukada et al. 1991). The concentration of gaseous iodine in air can be determined by passing a known volume of air through a tube containing activated charcoal, followed by extraction of the iodine from the charcoal and analysis by a number of techniques, including ion chromatography (Kim et al. 1981). Both the gaseous and particulate forms of iodine can be simultaneously assessed by passing a specified volume of air through a filtering device containing a series of filters with differing pore sizes and coatings (Gäbler and Heumann 1993; Tsukada et al. 1991). Both gaseous and particulate forms of iodine are trapped on the various filter stages, depending on the type of coating and pore size of the filter stage after a calibrated amount of air is pulled through the filters. For the analysis of ^{127}I on the filters, the filter is solvent extracted and the extracted iodine is analyzed by INAA (Sheridan and Zoller 1989; Tsukada et al. 1991), nondestructive neutron activation analysis (Dams et al. 1970), and isotope dilution mass spectrometry (Gäbler and Heumann 1993). Analysis of airborne ^{125}I , ^{129}I , and ^{131}I can also be performed using the filtering techniques described above, followed by a direct measurement by beta- or gamma-ray counting of these radioisotopes on the filter or within activated charcoal (Eadie et al. 1980; Luckett and Stotler 1980) or quantitated with more sensitive techniques (^{129}I) such as INAA (Tsukada et al. 1991).

For the analysis of iodine in water, there is a broad array of sample preparation and detection methodologies that are available (see Tables 7-3 and 7-4). A number of methods can directly quantitate iodine or its radioactive isotopes within a water sample using spectrophotometric, ion-selective electrodes, INAA, ICP-MS, polarography, or radiochemical techniques with minimal sample preparation and good detection sensitivities (0.1 – 2.0 $\mu\text{g}/\text{L}$ for ^{127}I , < 2 pCi/L for ^{131}I) (ASTM 1995, 1998, Beals and Hayes 1995; Beals et al. 1992; Butler and Gershey 1984; Jones et al. 1982; Prichard et al. 1981; Salbu et al. 1975; Sodd et al. 1975; Stephenson and Motycka 1994; Whitnack 1975). Some analytical methods provide for the analysis of total iodine in the sample as well as the various iodine species in water (e.g., I^- , I_2 , IO_3^- , and organic iodine) (Reifenhäuser and Heumann 1990; Wong and Cheng 1998). However, poor or inconsistent recovery of some iodine species (e.g., I^- and IO_3^-) during the ion exchange stage of the sample preparation, which is due to both irreversible binding of these iodine species to some ion exchange resins and interference from dissolved organic carbon, often can limit the accuracy of these methods for determining iodine species in aqueous samples (Stephenson and Motycka 1994).

7. ANALYTICAL METHODS

One of the more commonly used assays for analyzing iodine at $\mu\text{g/L}$ concentrations in water can be done directly using the catalytic spectrophotometric method. In the assay, iodine acts as a catalyst in the reduction of the ceric ions [Ce(IV)] by arsenous ions [As(III)]:

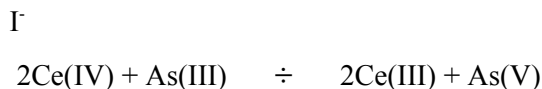

In the absence of iodine, the reaction is very slow (- 35 hours), but is on the order of minutes in the presence of iodine. The changes in the reaction rate, as followed by the decay in the Ce(IV) absorbance at either 420 or 366 nm, are inversely proportional to the iodine concentration in the sample (Jones et al. 1982; Lauber 1975; Truesdale and Smith 1975). This assay has been developed into an automated process offering the advantage of large sample batch analyses (Truesdale and Smith 1975).

However, like many of the methods that are used to quantitate iodine, a number of interferences can affect the measurement of iodine by the catalytic spectrophotometric method, including background coloration, turbidity, and compounds, such as Fe(II), that are capable of reducing Ce(IV) (Jones et al. 1982; Truesdale and Smith 1975). Thus, methods have been developed that purify iodine by first extracting iodine into an organic solvent and then back extracting the iodine into an appropriate aqueous solution for As–Ce catalytic spectrophotometric analysis (Jones et al. 1982; Whitehead 1979). Likewise, for most methods, there is often a need to preconcentrate, redox convert the various iodine species (e.g., I^- , I_2 , IO_3^-), and/or isolate iodine or its radioisotopes from the sample in order to improve sensitivity or remove interfering species, as is illustrated in Tables 7-3 and 7-4. Newer techniques have been developed to improve the separate quantitation of iodine species. An example is the use of ICP-MS to quantitate iodide directly in the samples after filtering, whereas iodine is quantitated as a vapor that is evolved from the sample following treatment of the sample with potassium nitrite in sulfuric acid. This approach provides a detection limit of $0.04 \mu\text{g/mL}$ and recoveries of 86.5–118.6% (Anderson et al. 1996)

The quantity of iodine and its radioisotopes in soil, sediments, minerals, vegetation, and biota is determined using detection methods similar to those described above (Tables 7-3 and 7-4). Analysis of iodine in samples by spectrophotometry, electrochemistry, and MS requires some form of sample digestion, either treatment in acid or pyrolysis. For most methods, sample concentration or purification is required to remove interfering species and/or improve detection sensitivity.

In the quantitation of ^{129}I in soil, mineral, and biological samples by the INAA method, improvements to the INAA method for determining ^{129}I have been developed to minimize the possible interferences that can occur from $^{133}\text{Cs}(n,\alpha)^{130}\text{I}$, $^{127}\text{I}(3n,\gamma)^{130}\text{I}$, $^{235}\text{U}(n,f)^{129}\text{I}$ as well as neutron capture by ^{128}Te and ^{130}Te . The presence of bromine within a particular sample also can interfere with the quantitation of ^{129}I due to the

7. ANALYTICAL METHODS

higher activity of ^{82}Br , the small difference in the photopeak maxima for ^{129}I (0.45 MeV) and ^{82}Br (0.55 MeV) and chemical similarities for I and Br (Ohno 1971; Rook et al. 1975). Most of these interferences have been eliminated through the use of preirradiation separation step that involves the combustion of iodine from biological materials followed by the collection of iodine on activated charcoal (Rook et al. 1975). A postirradiation step also has been developed using an electromagnetic mass separator with a hot cathode arc ion chamber source to separate and collect sample components within a specific mass range onto an aluminum foil for subsequent quantitation by a β - γ coincidence analysis system (Rook et al. 1975).

The detection limits, accuracy, and precision of any analytical methodology are important parameters in determining the appropriateness of a method to quantitate a specific analyte at the desired level of sensitivity within a particular matrix. The Lower Limit of Detection (LLD) has been adopted to refer to the intrinsic detection capability of a measurement procedure (sampling through data reduction and reporting) to aid in determining which method is best suited for the required sample quantitation (EML 1997; NRC 1984). Several factors influence the LLD, including background counting-rates, size or concentration of sample, detector sensitivity, recovery of desired analyte during sample isolation and purification, level of interfering contaminants, and, particularly, counting time. Because of these variables, the LLDs between laboratories, utilizing the same or similar measurement procedures, will vary.

The accuracy of a measurement technique in determining the quantity of a particular analyte in environmental samples is greatly dependent on the reliability of the calibrating technique. Thus, the availability of standard, certified radiation sources with known concentrations of iodine and its radioisotopes are required in order to insure the reliability of the calibration methods and accuracy of iodine measurements in environmental samples. NIST traceable standards for ^{127}I can be obtained through a number of commercial sources. The primary source of certified iodine radioisotope standards is the NIST. Standard reference materials for ^{129}I (SRM 4401LZ, 30 MBq [0.8 mCi]) and ^{131}I (SRM 4949C, 17 kBq [0.45 μCi]) are available from NIST. SRMs are also available for ^{127}I measurements, including SRM 1515 (apple leaves), SRM 1547 (peach leaves), SRM 1566 (oyster tissue), SRM 1572 (citrus leaves), SRM 1573 (tomato leaves), SRM 1575 (pine needles), SRM 1577 (bovine liver), SRM 1632 (coal), SRM 1633 (fly ash), SRM 1643 (water), SRM 2704 (sediment), and SRM 2709 (soil).

7.3 ADEQUACY OF THE DATABASE

Section 104(i)(5) of CERCLA, as amended, directs the Administrator of ATSDR (in consultation with the Administrator of EPA and agencies and programs of the Public Health Service) to assess whether adequate information on the health effects of iodine is available. Where adequate information is not available, ATSDR, in conjunction with the National Toxicology Program (NTP), is required to assure the initiation

7. ANALYTICAL METHODS

of a program of research designed to determine the health effects (and techniques for developing methods to determine such health effects) of iodine.

The following categories of possible data needs have been identified by a joint team of scientists from ATSDR, NTP, and EPA. They are defined as substance-specific informational needs that if met would reduce the uncertainties of human health assessment. This definition should not be interpreted to mean that all data needs discussed in this section must be filled. In the future, the identified data needs will be evaluated and prioritized, and a substance-specific research agenda will be proposed.

7.3.1 Identification of Data Needs

Methods for Determining Biomarkers of Exposure and Effect. Analytical methods with satisfactory sensitivity and precision are available to determine the levels of iodine and its radioisotopes in human tissues and body fluids.

Exposure. Analytical methods with satisfactory sensitivity and precision are available to determine the exposure levels of iodine and its radioisotopes in human tissues and body fluids.

Effect. Analytical methods with satisfactory sensitivity and precision are available to determine the levels of effect for iodine and its radioisotopes in human tissues and body fluids.

Methods for Determining Parent Compounds and Degradation Products in Environmental Media. Analytical methods with the required sensitivity and accuracy are available for quantitating iodine, both total and isotopic, in environmental matrices (Tables 7-3 and 7-4). Knowledge of the levels of iodine in various environmental media, along with appropriate modeling (see Chapters 2 and 4), can be used to evaluate potential human exposures through inhalation and ingestion pathways.

Whether in the environment or in the human body, iodine radioisotopes will undergo radioactive decay to form a series compounds that are also radioactive (see Chapter 3). Current analytical methods, such as mass spectrometry, have the necessary resolution and sensitivity to detect and quantitate these decay products.

7.3.2 Ongoing Studies

Current research studies, as provided by a search of the Federal Research in Progress (FEDRIP) database, are looking at improvements in the resolution and sensitivity of gamma ray scintillation spectrometers through the development of innovative scintillating materials. In the work proposed in the research grant entitled "Ultra-Compact Cesium Iodide - Mercuric Iodide Gamma-Ray Scintillation Spectrometer" (B.E.

7. ANALYTICAL METHODS

Patti, Principal Investigator), the investigators are working with CsI/HgI scintillation pairs to develop a room temperature gamma-spectrometer after having some preliminary success with the detection of the 660 keV gamma-ray from ^{137}Cs (4.58% FWHM) (FEDRIP 2000). In another study entitled “Bismuth Iodide Crystal Growth” (L.A. Boatner, Principal Investigator), the investigators are working on developing techniques for growing bismuth iodide crystals for room temperature radiation detectors and testing these crystals for their efficiency and energy resolution characteristics (FEDRIP 2000).

8. REGULATIONS AND ADVISORIES

The international, national, and state regulations and guidelines regarding stable iodine in air, water, and other media are summarized in Table 8-1. The regulations regarding radioactive iodine are summarized in Tables 8-2 and 8-3.

No MRLs were derived for inhalation exposure to stable or radioactive iodine. Oral MRLs of 0.01 mg/kg/day were derived for both acute- and chronic-duration exposures. No oral MRL was derived for intermediate-duration exposure.

The EPA has not classified iodine for human carcinogenicity, nor has the EPA derived reference concentrations (RfCs) or reference doses (RfDs) for stable or radioactive iodine (IRIS 2000).

8. REGULATIONS AND ADVISORIES

Table 8-1. Regulations and Guidelines Applicable to Stable Iodine

Agency	Description	Information	References
<u>INTERNATIONAL</u>			
Guidelines:			
IARC	Carcinogenicity classification	No data	
<u>NATIONAL</u>			
Regulations and Guidelines:			
a. Air			
ACGIH	STEL (ceiling)	0.1 ppm	ACGIH 2000
NIOSH	REL (ceiling) IDLH	0.1 ppm 2.0 ppm	NIOSH 2001
OSHA	PEL (ceiling)—general industry	0.1 ppm	OSHA 2001b 29CFR1910.1000
	PEL (ceiling)—construction industry	0.1 ppm	OSHA 2001a 29CFR1926.55
	PEL (ceiling)—shipyard industry	0.1 ppm	OSHA 2001c 29CFR1915.1000
b. Water			
EPA	Effluent limitation guidelines—inorganic chemicals manufacturing point source category for iodine production	Effluent reduction attainable by the application of BPT; no discharge of process wastewater pollutants to navigable waters	EPA 2001b 40CFR415.432
c. Food			
FDA	Drug products containing certain active ingredients offered over-the-counter for certain uses	Digestive aid and weight control drug product	FDA 2000a 21CFR310.545
	Drugs; recommended warning and caution statements—iodine and iodides (oral)	If a skin rash appears, discontinue use and consult physician	FDA 2000b 21CFR369.20
	Food additives permitted for direct addition to food for human consumption (as potassium iodide)		FDA 2000c 21CFR172.375
	Total amount for foods labeled without reference to age or physiological state	225 µg	

8. REGULATIONS AND ADVISORIES

Table 8-1. Regulations and Guidelines Applicable to Stable Iodine (continued)

Agency	Description	Information	References
NATIONAL (cont.)			
FDA (cont.)	Food additives permitted for direct addition to food for human consumption (as potassium iodide)		FDA 2000c 21CFR172.375
	Infants	45 µg	
	Children under 4 years of age	105 µg	
	Adults and children 4 or more years of age	225 µg	
	Pregnant or lactating women	300 µg	
	Food labeling—RDI	150 µg	FDA 2001b 21CFR101.9
	Indirect food additives—sanitizing solutions	Aqueous solution used on food and dairy processing equipment and utensils	FDA 2000d 21CFR178.1010 (b)(40)
	Nutrients—minimum amount per 100 kilocalories	5.0 µg	FDA 2001a
d. Other	Nutrition labeling of dietary supplements		FDA 2000e 21CFR101.36
	Nutritional quality guidelines		FDA 2000f 21CFR104.20 (d)(3)
	RDI ^a	150 µg	
	Amount per 100 calories ^b	7.5 µg	
	Trace minerals added to animal feeds—calcium iodate, calcium iodobenenate, cuprous iodide, 3,5-diiodosalicylic acid, ethylenediamine dihydroiodide, potassium iodate, potassium iodide, sodium iodate, sodium iodide, and thymol iodide	Recognized as safe when added at levels consistent with good feeding practice	FDA 2000i 21CFR582.80
ATF	List of denaturants authorized for denatured spirits		ATF 2001a 27CFR21.151
	List of products and processes using specially denatured alcohol and rum, and authorized formula		ATF 2001b 27CFR21.141

8. REGULATIONS AND ADVISORIES

Table 8-1. Regulations and Guidelines Applicable to Stable Iodine (continued)

Agency	Description	Information	References
<u>NATIONAL</u> (cont.)			
USC	List II chemical—regulated by the Attorney General as a chemical used in manufacturing a controlled substance		USC 2001 21USC802
<u>STATE</u>			
Regulations and Guidelines:			
a. Air			
Alaska	PEL (ceiling)	0.1 ppm	BNA 2001h
California	Airborne contaminant		BNA 2001h
	HAP		BNA 2001h
Hawaii	Air contaminant		BNA 2001h
Idaho	Toxic air pollutants		BNA 2001h
	OEL	0.1 mg/m ³	
	EL	6.7x10 ⁻³ pounds/hour	
	AAC (24-hour average)	5x10 ⁻³ mg/m ³	
Michigan	Occupational air contaminant—maximum allowable concentrations	0.1 ppm	BNA 2001h
	Limits for air contaminants PEL (ceiling)	0.1 ppm	BNA 2001h
Montana	Occupational air contaminant TLV	0.1 ppm	BNA 2001h
	Regulated toxic air pollutant OEL	1 mg/m ³	BNA 2001h
New Mexico	Toxic air pollutant and emissions		BNA 2001h
	OEL Emissions	0.1 ppm 6.67x10 ⁻² pounds/hour	
New York	Exposure limits PEL (ceiling)	0.1 ppm	BNA 2001h
	Air contaminant PEL (8-hour TWA)	0.1 ppm	BNA 2001h
Texas	Airborne contaminant		BNA 2001h
Vermont	Hazardous air contaminant		BNA 2001h

8. REGULATIONS AND ADVISORIES

Table 8-1. Regulations and Guidelines Applicable to Stable Iodine (continued)

Agency	Description	Information	References
STATE (cont.)			
Vermont	Hazardous air contaminants that cause short-term irritant effects Annual average Averaging time Action level	100 µg/m ³ 8 hours 4.2 pounds/8 hours	BNA 2001h
Washington	Toxic air pollutant and acceptable source impact levels	3.3 µg/m ³ per 24-hour average	BNA 2001h
b. Water			
Maine	Drinking water guideline—iodide ion	340 µg/L	HSDB 2001
Rhode Island	Water resources—toxic pollutant		BNA 2001h
c. Food			
		No data	
d. Other			
California	Hazardous substance list		BNA 2001h
Florida	Toxic substance in the workplace		BNA 2001h
Massachusetts	Oil and hazardous material list		BNA 2001h
Pennsylvania	Worker and Community Right-to-Know Act—hazardous substance list		BNA 2001h

^aRDI for adults and children 4 or more years of age

^b100 calories, based on 2,000 calorie intake as a daily standard

AAC = acceptable ambient concentrations; ACGIH = American Conference of Governmental Industrial Hygienists; ATF = Alcohol, Tobacco, and Firearms; BPT = best practicable control technology; BNA = Bureau of National Affairs; CFR = Code of Federal Regulations; EL = emissions level; EPA = Environmental Protection Agency; FDA = Food and Drug Administration; HAP = hazardous air pollutant; HSDB = Hazardous Substances Data Bank; IARC = International Agency for Research on Cancer; IDLH = immediately dangerous to life and health; NIOSH = National Institute of Occupational Safety and Health; OEL = occupational exposure limit; OSHA = Occupational Safety and Health Administration; PEL = permissible exposure limit; RDI = recommended daily intake; REL = relative exposure limit; STEL = short term exposure limit; TLV = threshold limit value; TWA = time weighted average; USC = United States Code

8. REGULATIONS AND ADVISORIES

Table 8-2. Regulations and Guidelines Applicable to Radioactive Iodine

Agency	Description	Information	References
<u>INTERNATIONAL</u>			
Guidelines:			
IARC	Carcinogenicity classification	No data	
ICRP	Occupational recommended dose limits ^a		ICRP 1991
	Effective dose	20 mSv per year, averaged over defined period of 5 years ^b	
	Annual equivalent dose		
	Lens of the eye	150 mSv	
	Skin ^c	500 mSv	
	Hands and feet	500 mSv	
	General population recommended dose limits ^a		ICRP 1991
	Effective dose	1 mSv per year ^d	
	Annual equivalent dose		
	Lens of the eye	15 mSv	
	Skin ^c	50 mSv	
	Hands and feet	No data	
<u>NATIONAL</u>			
Regulations and Guidelines:			
a. Air			
ACGIH	Effective dose		ACGIH 2000
	Any single year	50 mSv	
	Averaged over 5 years	20 mSv	
	Annual equivalent dose to		
	Lens of the eye	150 mSv	
	Skin	500 mSv	
	Hands and feet	500 mSv	
	Embryo-fetus exposures once the pregnancy is known		
	Monthly equivalent dose	0.5 mSv	
	Dose to the surface of women's abdomen (lower trunk)	2 mSv for the remainder of the pregnancy	
	Intake of radionuclide	1/20 ALI	
NIOSH	REL	No data	

8. REGULATIONS AND ADVISORIES

**Table 8-2. Regulations and Guidelines Applicable to Radioactive Iodine
(continued)**

Agency	Description	Information	References		
<u>NATIONAL</u> (cont.)					
NRC	Occupational values— <i>inhalation</i>	<u>ALI (μCi)</u> <u>DAC (μCi/mL)</u>	NRC 2001a 10CFR20, Appendix B		
	120 _I	1x10 ⁴ 4x10 ⁻⁶			
	120 _{mI}	2x10 ⁴ 9x10 ⁻⁶			
	121 _I	5x10 ⁴ 8x10 ⁻⁶			
	123 _I	6x10 ³ 3x10 ⁻⁶			
	124 _I	3x10 ² 3x10 ⁻⁸			
	125 _I	2x10 ² 3x10 ⁻⁸			
	126 _I	1x10 ² 1x10 ⁻⁸			
	128 _I	1x10 ⁵ 5x10 ⁻⁵			
	129 _I	3x10 ¹ 4x10 ⁻⁹			
	130 _I	2x10 ³ 3x10 ⁻⁷			
	131 _I	2x10 ² 2x10 ⁻⁸			
	132 _I	1x10 ⁴ 3x10 ⁻⁶			
	132 _{mI}	2x10 ⁴ 4x10 ⁻⁶			
	133 _I	9x10 ² 1x10 ⁻⁷			
	134 _I	5x10 ⁴ 2x10 ⁻⁵			
	135 _I	4x10 ³ 7x10 ⁻⁷			
		<i>Effluent concentrations (μCi/mL)</i>			NRC 2001a 10CFR20, Appendix B
	120 _I	2x10 ⁻⁸			
	120 _{mI}	3x10 ⁻⁸			
	121 _I	7x10 ⁻⁸			
	124 _I	4x10 ⁻¹⁰			
	125 _I	3x10 ⁻¹⁰			
	126 _I	2x10 ⁻¹⁰			
	128 _I	2x10 ⁻⁷			
129 _I	4x10 ⁻¹¹				
130 _I	3x10 ⁻⁹				
131 _I	2x10 ⁻¹⁰				
132 _I	2x10 ⁻⁸				
132 _{mI}	3x10 ⁻⁸				
133 _I	1x10 ⁻⁹				
134 _I	6x10 ⁻⁸				
135 _I	6x10 ⁻⁹				
OSHA	PEL (8-hour TWA)	No data			

8. REGULATIONS AND ADVISORIES

**Table 8-2. Regulations and Guidelines Applicable to Radioactive Iodine
(continued)**

Agency	Description	Information	References
<u>NATIONAL</u> (cont.)			
b. Water			
NRC	Effluent concentrations (μCi/mL)		NRC 2001a 10CFR20, Appendix B
	¹²⁰ I	1x10 ⁻⁴	
	^{120m} I	2x10 ⁻⁴	
	¹²¹ I	4x10 ⁻⁴	
	¹²⁴ I	2x10 ⁻⁶	
	¹²⁵ I	2x10 ⁻⁶	
	¹²⁶ I	1x10 ⁻⁶	
	¹²⁸ I	8x10 ⁻⁴	
	¹²⁹ I	2x10 ⁻⁷	
	¹³⁰ I	2x10 ⁻⁵	
	¹³¹ I	1x10 ⁻⁶	
	¹³² I	1x10 ⁻⁴	
	^{132m} I	1x10 ⁻⁴	
	¹³³ I	7x10 ⁻⁶	
	¹³⁴ I	4x10 ⁻⁴	
	¹³⁵ I	3x10 ⁻⁵	
	Releases to sewers—monthly average concentration (μCi/mL)		NRC 2001a 10CFR20, Appendix B
	¹²⁰ I	1x10 ⁻³	
	^{120m} I	2x10 ⁻³	
	¹²¹ I	4x10 ⁻³	
	¹²⁴ I	2x10 ⁻⁵	
	¹²⁵ I	2x10 ⁻⁵	
	¹²⁶ I	1x10 ⁻⁵	
	¹²⁸ I	8x10 ⁻³	
	¹²⁹ I	2x10 ⁻⁶	
	¹³⁰ I	2x10 ⁻⁴	
	¹³¹ I	1x10 ⁻⁵	
¹³² I	1x10 ⁻³		
^{132m} I	1x10 ⁻³		
¹³³ I	7x10 ⁻⁵		
¹³⁴ I	4x10 ⁻³		
¹³⁵ I	3x10 ⁻⁴		
c. Food			
FDA	Derived intervention levels (Bq/kg) ^e		FDA 1998
	PAG— ¹²⁹ I (thyroid)		
	3 months	50	
	1 year	110	
	5 years	76	
	10 years	72	
	15 years	56	
	Adult	69	
		84	

8. REGULATIONS AND ADVISORIES

**Table 8-2. Regulations and Guidelines Applicable to Radioactive Iodine
(continued)**

Agency	Description	Information	References
<u>NATIONAL</u> (cont.)			
FDA (cont.)	Derived intervention levels (Bq/kg) ^e		FDA 1998
	PAG — ¹³³ I (thyroid)	50	
	3 months	7,600	
	1 year	7,000	
	5 years	30,000	
	10 years	56,000	
	15 years	79,000	
	Adult	130,000	
	Sources of radiation used for food inspection—sealed units producing radiation (¹²⁵ I)	Not more than 2.2 million electron volts	FDA 2001h 21CFR179.21
	Requirements regarding certain radioactive drugs (¹³¹ I)	Diagnosis of thyroid functions; thyroid scans; treatment of hyperthyroidism and/or cardiac dysfunction; treatment of thyroid carcinoma	FDA 2001g 21CFR310.503
d. Other			
DOE	Radiation standards—DAC for controlling radiation exposure to workers at DOE facilities ^f		DOE 2001b 10CFR835, Appendix A
	(μ Ci/mL)		
	^{120m} I	9x10 ⁻⁶	
	¹²⁰ I	4x10 ⁻⁶	
	¹²¹ I	7x10 ⁻⁶	
	¹²³ I	3x10 ⁻⁶	
	¹²⁴ I	3x10 ⁻⁸	
	¹²⁵ I	3x10 ⁻⁸	
	¹²⁶ I	1x10 ⁻⁸	
	¹²⁸ I	5x10 ⁻⁵	
	¹²⁹ I	4x10 ⁻⁹	
	¹³⁰ I	3x10 ⁻⁷	
	¹³¹ I	2x10 ⁻⁸	
	^{132m} I	4x10 ⁻⁶	
	¹³² I	3x10 ⁻⁶	
	¹³³ I	1x10 ⁻⁷	
¹³⁴ I	2x10 ⁻⁵		
¹³⁵ I	7x10 ⁻⁷		

8. REGULATIONS AND ADVISORIES

**Table 8-2. Regulations and Guidelines Applicable to Radioactive Iodine
(continued)**

Agency	Description	Information	References			
NATIONAL (cont.)						
DOE	Radiation standards—DAC for workers from external exposure during immersion in contaminated atmospheric cloud (Ci/mL)	¹²² I	5x10 ⁻⁶	DOE 2001a 10CFR835, Appendix C		
		¹²⁸ I	5x10 ⁻⁵			
		¹³² I	2x10 ⁻⁶			
		¹³⁴ I	1x10 ⁻⁶			
		¹³⁵ I	7x10 ⁻⁷			
		¹³⁶ I	1x10 ⁻⁶			
	Values for establishing sealed radioactive source accountability and radioactive material posting and labeling requirements	¹²⁵ I	3.5x10 ²	DOE 2001c 10CFR835, Appendix E		
		¹²⁹ I	1.8x10 ²			
	DOT	General requirements for shipments and packagings—A1 and A2 values for radionuclides	<u>A1 (Ci)</u> <u>A2 (Ci)</u>	DOT 2001a 49CFR173.435		
			¹²³ I		6 162	
¹²⁴ I			0.9 24.3			
¹²⁵ I			2 54.1			
¹²⁶ I			0.9 24.3			
¹²⁹ I			Unlimited Unlimited			
¹³¹ I			0.5 13.5			
¹³² I			0.4 10.8			
¹³³ I			0.5 13.5			
¹³⁴ I			0.3 8.11			
¹³⁵ I			0.3 13.5			
Hazardous substance and reportable quantity (Ci)			¹²⁰ I		10	DOT 2001b 49CFR171.101, Appendix A
			^{120m} I		100	
			¹²¹ I		100	
			¹²³ I		10	
			¹²⁴ I		0.1	
			¹²⁵ I		0.01	
	¹²⁶ I	0.01				
	¹²⁸ I	1,000				
	¹²⁹ I	0.001				
	¹³⁰ I	1				
¹³¹ I	0.01					

8. REGULATIONS AND ADVISORIES

**Table 8-2. Regulations and Guidelines Applicable to Radioactive Iodine
(continued)**

Agency	Description	Information	References			
NATIONAL (cont.)						
DOT	Hazardous substance and reportable quantity (Ci)		DOT 2001b 49CFR171.101, Appendix A			
		¹³² I		10		
		^{132m} I		10		
		¹³³ I		0.1		
		¹³⁴ I		100		
	¹³⁵ I	10				
EPA	Annual possession quantities for environmental compliance (Ci/year)	<u>Gas</u>	EPA 2001a 40CFR61, Appendix E			
		<u>Liquid/ Powder</u>				
		<u>Solid</u>				
		¹²³ I		4.9x10 ⁻¹	4.9x10 ²	4.9x10 ⁵
		¹²⁴ I		9.3x10 ⁻³	9.3x10 ⁰	9.3x10 ³
		¹²⁵ I		6.2x10 ⁻³	6.2x10 ⁰	6.2x10 ³
		¹²⁶ I		3.7x10 ⁻³	3.7x10 ⁰	3.7x10 ³
		¹²⁸ I		9.3x10 ⁰	9.3x10 ³	9.3x10 ⁶
		¹²⁹ I		2.6x10 ⁻⁴	2.6x10 ⁻¹	2.6x10 ²
		¹³⁰ I		4.6x10 ⁻²	4.6x10 ¹	4.6x10 ⁴
		¹³¹ I		6.7x10 ⁻³	6.7x10 ⁰	6.7x10 ³
		¹³² I		2.0x10 ⁻¹	2.0x10 ²	2.0x10 ⁵
		¹³³ I		6.7x10 ⁻²	6.7x10 ¹	6.7x10 ⁴
		¹³⁴ I		3.2x10 ⁻¹	3.2x10 ²	3.2x10 ⁵
		¹³⁵ I		1.2x10 ⁻¹	1.2x10 ²	1.2x10 ⁵
				Release limits for containment ^g		BNA 2001e 40CFR191, Appendix A
				¹²⁹ I	100 Ci	
				Reportable quantity (Ci)		BNA 2001f 40CFR302.4, Appendix B
				^{120m} I	100	
				¹²⁰ I	10	
	¹²¹ I	100				
	¹²³ I	10				
	¹²⁴ I	0.1				
	¹²⁵ I	0.01				
	¹²⁶ I	0.01				
	¹²⁸ I	1,000				
	¹²⁹ I	0.001				
	¹³⁰ I	1				
	¹³¹ I	0.01				
	^{132m} I	10				
	¹³² I	10				
	¹³³ I	0.1				
	¹³⁴ I	100				
	¹³⁵ I	10				

8. REGULATIONS AND ADVISORIES

**Table 8-2. Regulations and Guidelines Applicable to Radioactive Iodine
(continued)**

Agency	Description	Information	References
<u>NATIONAL</u> (cont.)			
EPA	Carcinogenicity slope factors ^h		EPA 1997g
	Ingestion (lifetime risk per pCi) ^b		
	122I	2.16x10 ⁻¹⁴	
	123I	5.42x10 ⁻¹³	
	125I	2.58x10 ⁻¹¹	
	126I	4.82x10 ⁻¹¹	
	129I	1.84x10 ⁻¹⁰	
	130I	4.85x10 ⁻¹²	
	131I	3.62x10 ⁻¹¹	
	132I	6.62x10 ⁻¹³	
	133I	1.06x10 ⁻¹¹	
	134I	2.31x10 ⁻¹³	
	135I	2.27x10 ⁻¹²	
	Inhalation (lifetime risk per pCi) ⁱ		
	122I	2.24x10 ⁻¹⁴	
	123I	2.94x10 ⁻¹³	
	125I	1.71x10 ⁻¹¹	
	126I	3.15x10 ⁻¹¹	
	129I	1.22x10 ⁻¹⁰	
	130I	2.61x10 ⁻¹²	
	131I	2.33x10 ⁻¹¹	
	132I	3.52x10 ⁻¹³	
	133I	6.02x10 ⁻¹²	
	134I	1.38x10 ⁻¹³	
	135I	1.18x10 ⁻¹²	
	External exposure (risk/year per pCi/g soil) ^j		
	122I	3.41x10 ⁻⁶	
	123I	2.52x10 ⁻⁷	
	125I	2.39x10 ⁻⁹	
	126I	1.49x10 ⁻⁶	
	129I	2.69x10 ⁻⁹	
	130I	7.93x10 ⁻⁶	
	131I	1.25x10 ⁻⁶	
	132I	8.75x10 ⁻⁶	
	133I	2.20x10 ⁻⁶	
	134I	1.02x10 ⁻⁵	
	135I	6.23x10 ⁻⁶	

8. REGULATIONS AND ADVISORIES

**Table 8-2. Regulations and Guidelines Applicable to Radioactive Iodine
(continued)**

Agency	Description	Information	References	
<u>NATIONAL</u> (cont.)				
NCRP	Occupational exposures ^k		NCRP 1993	
	Effective dose limits			
	Annual	50 mSv		
	Cumulative	10 mSv x age		
	Equivalent dose annual limits for tissues and organs			
	Lens of eye	150 mSv		
	Skin, hands, and feet	500 mSv		
	Public exposures (annual)			NCRP 1993
	Effective dose limit, continuous or frequent exposure ^k	1 mSv		
	Effective dose limit, infrequent exposure ^k	5 mSv		
NCRP	Public exposures (annual)		NCRP 1993	
	Equivalent dose limits for tissues and organs ^k			
	Lens of eye	15 mSv		
	Skin, hands, and feet	50 mSv		
NRC	ALI (μCi)—oral ingestion		NRC 2001a 10CFR20, Appendix B	
	¹²⁰ I	8x10 ³		
	^{120m} I	1x10 ⁴		
	¹²¹ I	3x10 ⁴		
	¹²³ I	3x10 ³		
	¹²⁴ I	2x10 ²		
	¹²⁵ I	1x10 ²		
	¹²⁶ I	7x10 ¹		
	¹²⁸ I	6x10 ⁴		
	¹²⁹ I	2x10 ¹		
	¹³⁰ I	1x10 ³		
	¹³¹ I	9x10 ¹		
	¹³² I	9x10 ³		
	^{132m} I	1x10 ⁴		
	¹³³ I	5x10 ²		
	¹³⁴ I	3x10 ⁴		
	¹³⁵ I	3x10 ³		

8. REGULATIONS AND ADVISORIES

**Table 8-2. Regulations and Guidelines Applicable to Radioactive Iodine
(continued)**

Agency	Description	Information			References																																																	
<u>NATIONAL (cont.)</u>																																																						
NRC	Byproduct material listing (Ci)	<table border="1"> <thead> <tr> <th></th> <th>Column I^l</th> <th>Column II^m</th> <th></th> </tr> </thead> <tbody> <tr> <td>¹²⁵I</td> <td>0.1</td> <td>0.00</td> <td></td> </tr> <tr> <td>¹²⁶I</td> <td>0.1</td> <td>0.001</td> <td></td> </tr> <tr> <td>¹²⁹I</td> <td>0.1</td> <td>0.01</td> <td></td> </tr> <tr> <td>¹³¹I</td> <td>0.1</td> <td>0.001</td> <td></td> </tr> <tr> <td>¹³²I</td> <td>10</td> <td>0.1</td> <td></td> </tr> <tr> <td>¹³³I</td> <td>1</td> <td>0.01</td> <td></td> </tr> <tr> <td>¹³⁴I</td> <td>10</td> <td>0.1</td> <td></td> </tr> <tr> <td>¹³⁵I</td> <td>1</td> <td>0.01</td> <td></td> </tr> </tbody> </table>				Column I ^l	Column II ^m		¹²⁵ I	0.1	0.00		¹²⁶ I	0.1	0.001		¹²⁹ I	0.1	0.01		¹³¹ I	0.1	0.001		¹³² I	10	0.1		¹³³ I	1	0.01		¹³⁴ I	10	0.1		¹³⁵ I	1	0.01		NRC 2001b 10CFR33.100, Schedule A													
		Column I ^l	Column II ^m																																																			
	¹²⁵ I	0.1	0.00																																																			
	¹²⁶ I	0.1	0.001																																																			
	¹²⁹ I	0.1	0.01																																																			
	¹³¹ I	0.1	0.001																																																			
	¹³² I	10	0.1																																																			
	¹³³ I	1	0.01																																																			
	¹³⁴ I	10	0.1																																																			
	¹³⁵ I	1	0.01																																																			
		Individual monitoring ¹³¹ I	1 Ci			BNA 2001a 10CFR20.2206																																																
		Laboratory testing and use ¹²⁵ I and ¹³¹ I	#10 µCi			BNA 2001b 10CFR32.71																																																
		Packaging and transportation of radioactive material —determination of A1 and A2	<table border="1"> <thead> <tr> <th></th> <th>A1 (Ci)</th> <th>A2 (Ci)</th> <th>Specific Activity</th> </tr> </thead> <tbody> <tr> <td>¹²³I</td> <td>6</td> <td>162</td> <td>1.9x10⁶</td> </tr> <tr> <td>¹²⁴I</td> <td>0.9</td> <td>24.3</td> <td>2.5x10⁵</td> </tr> <tr> <td>¹²⁵I</td> <td>2</td> <td>54.1</td> <td>1.7x10⁴</td> </tr> <tr> <td>¹²⁶I</td> <td>0.9</td> <td>24.3</td> <td>8.0x10⁴</td> </tr> <tr> <td>¹²⁹I</td> <td>Unlimited</td> <td>Unlimited</td> <td>1.8x10⁴</td> </tr> <tr> <td>¹³¹I</td> <td>0.5</td> <td>d</td> <td>1.2x10⁵</td> </tr> <tr> <td>¹³²I</td> <td>0.4</td> <td>13.5</td> <td>1.0x10⁷</td> </tr> <tr> <td>¹³³I</td> <td>0.5</td> <td>10.8</td> <td>1.1x10⁶</td> </tr> <tr> <td>¹³⁴I</td> <td>0.3</td> <td>13.5</td> <td>2.7x10⁷</td> </tr> <tr> <td>¹³⁵I</td> <td>0.5</td> <td>8.11</td> <td>3.5x10⁶</td> </tr> <tr> <td></td> <td></td> <td>13.5</td> <td></td> </tr> </tbody> </table>				A1 (Ci)	A2 (Ci)	Specific Activity	¹²³ I	6	162	1.9x10 ⁶	¹²⁴ I	0.9	24.3	2.5x10 ⁵	¹²⁵ I	2	54.1	1.7x10 ⁴	¹²⁶ I	0.9	24.3	8.0x10 ⁴	¹²⁹ I	Unlimited	Unlimited	1.8x10 ⁴	¹³¹ I	0.5	d	1.2x10 ⁵	¹³² I	0.4	13.5	1.0x10 ⁷	¹³³ I	0.5	10.8	1.1x10 ⁶	¹³⁴ I	0.3	13.5	2.7x10 ⁷	¹³⁵ I	0.5	8.11	3.5x10 ⁶			13.5		NRC 2001C 10CFR71, Appendix A
		A1 (Ci)	A2 (Ci)	Specific Activity																																																		
	¹²³ I	6	162	1.9x10 ⁶																																																		
¹²⁴ I	0.9	24.3	2.5x10 ⁵																																																			
¹²⁵ I	2	54.1	1.7x10 ⁴																																																			
¹²⁶ I	0.9	24.3	8.0x10 ⁴																																																			
¹²⁹ I	Unlimited	Unlimited	1.8x10 ⁴																																																			
¹³¹ I	0.5	d	1.2x10 ⁵																																																			
¹³² I	0.4	13.5	1.0x10 ⁷																																																			
¹³³ I	0.5	10.8	1.1x10 ⁶																																																			
¹³⁴ I	0.3	13.5	2.7x10 ⁷																																																			
¹³⁵ I	0.5	8.11	3.5x10 ⁶																																																			
		13.5																																																				
	Quantities requiring consideration of the need for an emergency plan— ¹²⁵ I and ¹³¹ I				BNA 2001c 10CFR30.72, Schedule C																																																	
	Release fraction	0.5%																																																				
	Quantity	10 Ci																																																				

8. REGULATIONS AND ADVISORIES

**Table 8-2. Regulations and Guidelines Applicable to Radioactive Iodine
(continued)**

Agency	Description	Information	References	
<u>NATIONAL</u> (cont.)				
NRC	Standards for protection against radiation—quantities of licensed material requiring labeling (μCi)	^{120m} I	1,000	BNA 2001d 10CFR20, Appendix C
		¹²⁰ I	100	
		¹²¹ I	1,000	
		¹²³ I	100	
		¹²⁴ I	10	
		¹²⁵ I	1	
		¹²⁶ I	1	
		¹²⁸ I	1,000	
		¹²⁹ I	1	
		¹³⁰ I	10	
		¹³¹ I	1	
		^{132m} I	100	
		¹³² I	100	
		¹³³ I	10	
		¹³⁴ I	1,000	
		¹³⁵ I	100	
			Waste classification —concentration of ¹²⁹ I	
<u>STATE</u>				
Regulations and Guidelines:				
a. Air		No data		
b. Water				
Kentucky	Maximum groundwater contaminant level ¹³¹ I	3 pCi/L	BNA 2001	
c. Food		No data		
d. Other				
Arkansas	Licensing of radioactive materials—exempt concentrations (Ci/mL, solids are Ci/g)		BNA 2001	
	¹²⁶ I	<u>Column 1^l</u> 3x10 ⁻⁹	<u>Column 2^m</u> 2x10 ⁻⁵	
	¹³¹ I	3x10 ⁻⁹	2x10 ⁻⁵	
	¹³² I	8x10 ⁻⁸	6x10 ⁻⁴	
	¹³³ I	1x10 ⁻⁸	7x10 ⁻⁵	
	¹³⁴ I	2x10 ⁻⁷	1x10 ⁻³	

8. REGULATIONS AND ADVISORIES

**Table 8-2. Regulations and Guidelines Applicable to Radioactive Iodine
(continued)**

Agency	Description	Information		References	
<u>STATE (cont.)</u>					
California	Licensing of radioactive materials—Schedule C ($\mu\text{Ci}/\text{mL}$)		<u>Column 1^l</u>	<u>Column 2^m</u>	BNA 2001
		¹²⁶ I	3×10^{-9}	2×10^{-5}	
		¹³¹ I	3×10^{-9}	2×10^{-3}	
		¹³² I	8×10^{-8}	6×10^{-4}	
		¹³³ I	1×10^{-8}	7×10^{-3}	
		¹³⁴ I	2×10^{-7}	1×10^{-3}	
Florida	Quantities requiring consideration of the need for an emergency plan— ¹²⁵ I and ¹³¹ I	Release fraction	0.5%		BNA 2001
		Quantity	10 Ci		
Indiana	Licensing of radioactive materials—Schedule A; exempt concentrations ($\mu\text{Ci}/\text{mL}$)		<u>Column 1^l</u>	<u>Column 2^m</u>	BNA 2001
		¹²⁶ I	3×10^{-9}	2×10^{-5}	
		¹³¹ I	3×10^{-9}	2×10^{-3}	
		¹³² I	8×10^{-8}	6×10^{-4}	
		¹³³ I	1×10^{-8}	7×10^{-3}	
		¹³⁴ I	2×10^{-7}	1×10^{-3}	
Kansas	Licensing of sources of radiation—Schedule B; exempt quantities of radioactive material (μCi)	¹²³ I	100		BNA 2001
		¹²⁵ I	1		
		¹²⁶ I	1		
		¹²⁹ I	0.1		
		¹³¹ I	1		
		¹³² I	10		
		¹³³ I	1		
		¹³⁴ I	10		
		¹³⁵ I	10		

8. REGULATIONS AND ADVISORIES

**Table 8-2. Regulations and Guidelines Applicable to Radioactive Iodine
(continued)**

Agency	Description	Information	References
STATE (cont.)			
Louisiana	Standards for protection against radiation		BNA 2001
	120m ^l	100	
	120 ^l	10	
	121 ^l	100	
	123 ^l	10	
	124 ^l	0.1	
	125 ^l	0.01	
	126 ^l	0.01	
	128 ^l	1,000	
	129 ^l	0.001	
	130 ^l	1	
	131 ^l	0.01	
	132m ^l	10	
	132 ^l	10	

^aThe limits apply to the sum of the relevant doses from external exposure in the specified period and the 50-year committed dose (to age 70 years for children) from intakes in the same period.

^bWith the further provision that the effective dose should not exceed 50 mSv in any single year. Additional restrictions apply to the occupational exposure of pregnant women.

^cThe limitation on the effective dose provides sufficient protection for the skin against stochastic effects. An additional limit is needed for localized exposures in order to prevent deterministic effects.

^dIn special circumstances, a higher value of effective dose could be allowed in a single year, provided that the average over 5 years does not exceed 1 mSv per year.

^eDerived intervention levels (DIL) are concentrations of radioactivity in food whose consumption would deliver a committed effective dose equivalent equal to the most limiting of the protection action guides (PAGs) developed by FDA (1998).

^fClass D: approximate length of retention in the pulmonary region is less than 10 days.

^gRelease limit per 1,000 metric tons of heavy metal or other unit of waste.

^hRadioactive slope factors calculated by EPA's Office of Radiation and Indoor Air (ORIA). Slope factors are central estimates in a linear model of the age-averaged, lifetime attributable radiation cancer incidence (fatal and nonfatal cancer) risk per unit of activity ingested, expressed as risk per picocurie (pCi).

ⁱInhalation slope factors are central estimates in a linear model of the age-average, lifetime attributable radiation cancer incidence (fatal and nonfatal cancer) risk per unit of activity inhaled, expressed as risk per picocurie (pCi).

^jExternal slope factors are central estimates of the lifetime attributable radiation cancer incidence risk for each year of exposure to external radiation from photon-emitting radionuclides distributed uniformly in a thick layer of soil, expressed as risk/year per pCi per gram of soil.

^kSum of external and internal exposures but excluding doses from natural sources.

^lColumn 1: gas concentration

^mColumn 2: liquid and solid concentration

ACGIH = American Conference of Governmental Industrial Hygienists; ALI = annual limits on intake; BNA = Bureau of National Affairs; CFR = Code of Federal Regulations; DAC = derived air concentrations; DOE = Department of Energy; DOT = Department of Transportation; EPA = Environmental Protection Agency; FDA = Food and Drug Administration; IARC = International Agency for Research on Cancer; ICRP = International Commission on Radiological Protection; mSv = millisievert; NIOSH = National Institute of Occupational Safety and Health; NCRP = National Council on Radiation Protection; NRC = Nuclear Regulatory Commission; OSHA = Occupational Safety and Health Administration; PAG = protective action guide; PEL = permissible exposure limit; REL = relative exposure limit; TLV = threshold limit value; TWA = time-weighted average

8. REGULATIONS AND ADVISORIES

Table 8-3. Dose Coefficients^a (e(50)) for Intakes of Iodine Radionuclides

Radio-nuclide	Half-life	f1 ^c	Inhalation, 1µm AMAD ^b	Inhalation, 5µm AMAD	Ingestion
			e(50)	e(50)	e(50)
¹²⁰ I	1.35/hour	1.0	1.0x10 ⁻¹⁰	1.9x10 ⁻¹⁰	3.4x10 ⁻¹⁰
^{120m} I	0.883/hour	1.0	8.7x10 ⁻¹¹	1.4x10 ⁻¹⁰	2.1x10 ⁻¹⁰
¹²¹ I	2.12/hour	1.0	2.8x10 ⁻¹¹	3.9x10 ⁻¹¹	8.2x10 ⁻¹¹
¹²³ I	13.2/hour	1.0	7.6x10 ⁻¹¹	1.1x10 ⁻¹⁰	2.1x10 ⁻¹⁰
¹²⁴ I	4.18/day	1.0	4.5x10 ⁻⁹	6.3x10 ⁻⁹	1.3x10 ⁻⁸
¹²⁵ I	60.1/day	1.0	5.3x10 ⁻⁹	7.3x10 ⁻⁹	1.5x10 ⁻⁸
¹²⁶ I	13.0/day	1.0	1.0x10 ⁻⁸	1.4x10 ⁻⁸	2.9x10 ⁻⁸
¹²⁸ I	0.416/hour	1.0	1.4x10 ⁻¹¹	2.2x10 ⁻¹¹	4.6x10 ⁻¹¹
¹²⁹ I	1.57x10 ⁷ /year	1.0	3.7x10 ⁻⁸	5.1x10 ⁻⁸	1.1x10 ⁻⁷
¹³⁰ I	12.4/hour	1.0	6.9x10 ⁻¹⁰	9.6x10 ⁻¹⁰	2.0x10 ⁻⁹
¹³¹ I	8.04/day	1.0	7.6x10 ⁻⁹	1.1x10 ⁻⁸	2.2x10 ⁻⁸
¹³² I	2.30/hour	1.0	9.6x10 ⁻¹¹	2.0x10 ⁻¹⁰	2.9x10 ⁻¹⁰
^{132m} I	1.39/hour	1.0	8.1x10 ⁻¹¹	1.1x10 ⁻¹⁰	2.2x10 ⁻¹⁰
¹³³ I	20.8/hour	1.0	1.5x10 ⁻⁹	2.1x10 ⁻⁹	4.3x10 ⁻⁹
¹³⁴ I	0.876/hour	1.0	4.8x10 ⁻¹¹	7.9x10 ⁻¹¹	1.1x10 ⁻¹⁰
¹³⁵ I	6.61/hour	1.0	3.3x10 ⁻¹⁰	4.6x10 ⁻¹⁰	9.3x10 ⁻¹⁰

^aICRP (1994)

^bICRP (1994) calculated inhalation dose coefficients for particles with AMAD of 1 or 5 µm.

^cFractional absorption factor used by ICRP (1994, Annexes E and F) to calculate effective dose coefficients.

ALI = annual limits on intake; AMAD = activity median average diameters; Ci = curies

9. REFERENCES

Abbott A, Barker S. 1996. Chernobyl damage 'underestimated'. *Nature* 380:658.

Abdel-Nabi H, Ortman JA. 1983. Radiobiological effects of ^{131}I and ^{125}I on the DNA of the rat thyroid: I. Comparative study with emphasis on the postradiation hypothyroidism occurrence. *Radiat Res* 93:525-533.

*Abdullah ME, Said SA. 1981. Release and organ distribution of ^{125}I from povidone-iodine under the influence of certain additives. *Arzneim Forsch* 31(1):59-61.

Abel MS, Blume AJ, Garrett KM. 1989. Differential effects of iodide and chloride on allosteric interactions of the GABA_A receptor. *J Neurochem* 53:940-945.

*Aboul-Khair SA, Buchanan TJ, Crooks J, et al. 1966. Structural and functional development of the human foetal thyroid. *Clin Sci* 31:415-424.

Aboul-Khair SA, Crooks J, Turnbull AC, et al. 1964. The physiological changes in thyroid function during pregnancy. *Clin Sci* 27:195-207.

Absil AC, Buxeraud J, Raby C. 1984. [Charge-transfer complexation of chlorpromazine in the presence of iodine; thyroid side effect of this molecule.] *Can J Chem* 62(9):1807-1811. (French)

ACGIH. 1992. Iodine. In: Documentation of the threshold limit values and biological exposure indices. Sixth Edition. Volume II. American Conference of Governmental Industrial Hygienists Inc. Cincinnati, OH.

*ACGIH. 2000. Threshold limit values for chemical substances and physical agents and biological exposure indices. American Conference of Governmental Industrial Hygienists Inc. Cincinnati, OH.

Adamson AS, Gardham JRC. 1991. Post ^{131}I carcinoma of the thyroid. *Postgrad Med J* 67:289-290.

*Adinolfi M. 1985. The development of the human blood-CSF-brain barrier. *Dev Med Child Neurol* 27:532-537.

*Adlercreutz H. 1995. Phytoestrogens: Epidemiology and a possible role in cancer protection. *Environ Health Perspect Suppl* 103(7):103-112.

Advani SH, Hege UP. 1992. Leukemia after ^{131}I treatment of thyroid cancer-comments on the article second cancer following chemotherapy and radiotherapy-an epidemiological perspective by J. Kaldor. *Acta Oncol* 31(1):65.

*AEC. 1968. Fission product inhalation program annual report 1967-1968. Lovelace Foundation for Medical Education and Research for U.S. Atomic Energy Commission. LF-39, UC-48.

AEC. 1970. Medical survey of the people of Rongelap and Utirik Islands thirteen, fourteen, and fifteen years after exposure to fallout radiation (March 1967, March 1968, and March 1969). Brookhaven National Laboratory for U.S. Atomic Energy Commission. BNL 50220 (T-562).

*AEC. 1974. U.S. Atomic Energy Commission. Environmental behavior and radiation doses from iodine-129. BNWL-SA-4879.

*Cited in text

9. REFERENCES

- *AEC. 1966. I-129 as a geochemical and ecological tracer. U.S. Atomic Energy Commission. Pittsburgh, PA: Carnegie Institute of Technology. Report No. NYO-3624-1.
- AECEB. 1986. Transfer of radionuclides from the environment to human milk - A review. Ottawa, Canada: Atomic Energy Control Board. INFO-0192. NTIS DE 88705117.
- AECEB. 1994. Radioactive emission data from Canadian nuclear generating stations 1972 to 1992. Ottawa, Canada: Atomic Energy Control Board. INFO-0210(e) Rev-5. NTIS MIC-95-00188.
- AECL. 1994. Atomic Energy of Canada, Ltd. Review and assessment of methods for the measurement and speciation of iodine in fresh water. NTIS PB95-160487.
- Agerbaek H. 1974. Weight and iodine content of the thyroid gland in Jutland, Denmark [Letter]. *Acta Med Scand* 196:505.
- Aggett PJ. 1998. Neonatal trace element metabolism. In: Cowett RM, ed. *Principles of perinatal-neonatal metabolism*. New York, NY: Springer, 909-941.
- *Aghini-Lombardi A, Antonangeli L, Martinon E, et al. 1999. The spectrum of thyroid disorders in an iodine-deficient community: The Pescopagano survey. *J Clin Endocrinol Metab* 84:561-566.
- Ahlgren L, Ivarsson S, Johansson L, et al. 1985. Excretion of radionuclides in human breast milk after the administration of radiopharmaceuticals. *J Nucl Med* 26:1085-1090.
- *Ahmed M, Doe RP, Nuttall FQ. 1974. Triiodothyronine thyrotoxicosis following iodide ingestion: A case report. *J Clin Endocrinol Metab* 38:574-576.
- *Ahmed SR, Shalet SM. 1984. Radioactive iodine and testicular damage. *N Engl J Med* 311:1576.
- *Ahmed SR, Shalet SM. 1985. Gonadal damage due to radioactive iodine (I^{131}) treatment for thyroid carcinoma. *Postgrad Med J* 61:361-362.
- Ahn C-S, Rosenberg IN. 1968. Prompt stimulation of the organic binding of iodine in the thyroid by adenosine 3',5'-phosphate in vivo. *Proc Natl Acad Sci U S A* 60(3):830-835.
- Ahn CS, Rosenberg IN. 1970. Iodine metabolism in thyroid slices: Effects of TSH, dibutyryl cyclic 3',5'-AMP, NaF and prostaglandin E. *Endocrinology* 86:396-405.
- Ahnstrom G, Ehrenberg L, Hussain S, et al. 1970. On the killing and mutagenic action in *e. coli* associated with the Auger effect during ^{125}I decay. *Mutat Res* 10:247-250.
- Ahren B, Rerup C. 1987. Kinetics of radioiodine released from prelabelled thyroid gland *in vivo*: Influence of propylthiouracil. *Pharmacol Toxicol* 61:69-71.
- Aiba M, Ninomiya J, Furuya K, et al. 1999. Induction of a critical elevation of povidone-iodine absorption in the treatment of a burn patient: Report of a case. *Jpn J Surg* 29:157-159.
- Aii T, Kume A, Takahashi S, et al. 1990. The effect of the radionuclides from Chernobyl on iodine-131 and cesium-137 contents in milk and pastures in south-western Japan. *Jpn J Zootech Sci* 61(1):47-53.
- Aizawa Y, Yoshida K, Kaise N, et al. 1997. The development of transient hypothyroidism after iodine-131 treatment in hyperthyroid patients with Graves' disease: Prevalence, mechanism and prognosis. *Clin Endocrinol* 46:1-5.

9. REFERENCES

- *Akamizu T, Ikuyama S, Saji M, et al. 1990. Cloning, chromosomal assignment, and regulation of the rat thyrotropin receptor: Expression of the gene is regulated by thyrotropin, agents that increase cAMP levels, and thyroid autoantibodies. *Proc Natl Acad Sci U S A* 87:5677-5681.
- Akerib M. 1971. Iodine toxic to young animals. *Worlds Poult Sci J* 27(1):35-37.
- Akleyev AV. 1996. Experience with the studies of medical and biological effects of radiation incidents in the south Urals. In: Nagasaki S, Yamashita S, eds. *Nagasaki symposium radiation and human health: Proposal from Nagasaki*. Amsterdam, the Netherlands: Elsevier, 117-126.
- Aktay R, Rezai K, Seabold JE, et al. 1996. Four- to twenty-four hour uptake ratio: An index of rapid iodine-131 turnover in hyperthyroidism. *J Nucl Med* 37:1815-1819.
- Albinsson Y, Engkvist I. 1989. Diffusion of americium, plutonium, uranium, neptunium, cesium, iodine and technetium in compacted sand-bentonite mixture. *Chalmers University of Technology, Department of Nuclear Chemistry, Goeteborg, Sweden. SKB Tech. Rep.* 89-22.
- Albinsson Y, Engkvist I. 1991. Diffusion of Am, Pu, U, Np, Cs, I and Tc in compacted sand-bentonite mixture. *Radioact Waste Manage Nucl Fuel Cycle* 15(4):221-239.
- Albrecht HH, Creutzig H. 1976. [Salivary gland scintigraphy after radio-iodine therapy. Functional scintigraphy of the salivary gland after high dose radio-iodine therapy (author's translation).] *Fortschr Geb Rontgenstrahlen Nuklearned Ergänzungsbd* 125(6):546-551. (German)
- Alexander C, Bader JB, Schaefer A, et al. 1998. Intermediate and long-term side effects of high-dose radioiodine therapy for thyroid carcinoma. *J Nucl Med* 39:1551-1554.
- *Allegrini M, Pennington JAT, Tanner JT. 1983. Total diet study: Determination of iodine intake by neutron activation analysis. *J Amer Diet Assoc* 83:18-24.
- Allen EM. 1993. Acute iodine ingestion increases intrathyroidal glutathione. *J Endocrinol Invest* 16:265-270.
- *Allen EM, Braverman LE. 1990. The effect of iodine on lymphocytic thyroiditis in the thymectomized Buffalo rat. *Endocrinology* 127(4):1613-1616.
- *Allen EM, Appel MC, Braverman LE. 1986. The effect of iodide ingestion on the development of spontaneous lymphocytic thyroiditis in the diabetes-prone BB/W rat. *Endocrinology* 118(5):1977-1981.
- Allen EM, Appel MC, Braverman LE. 1987. Iodine-induced thyroiditis and hypothyroidism in the hemithyroidectomized BB/W rat. *Endocrinology* 121:481-485.
- *Allweiss P, Braunstein GD, Katz A, et al. 1984. Sialadenitis following I-131 therapy for thyroid carcinoma: Concise communication. *J Nucl Med* 25:755-758.
- Al-Rashood KA, Haggga MEM, Al-Khamees HA, et al. 1995. Differential pulse polarographic and spectrophotometric methods for the determination of trace amounts of iodide in Saudi waters. *Saudi Pharm J* 3(4):181-187.
- *Altman PL, Dittmer DS. 1974. In: *Biological handbooks: Biology data book*. Vol. III. 2nd ed. Bethesda, MD: Federation of American Societies for Experimental Biology, 1987-2008, 2041.
- Alvarez E. 1979. Neutropenia in a burned patient being treated topically with povidone-iodine foam. *Plast Reconstr Surg* 63(6):839-840.

9. REFERENCES

- Amdur MO. 1978. Respiratory response to iodine vapor alone and with sodium chloride aerosol. *J Toxicol Environ Health* 4:619-630.
- Amiro BD, Sheppard SC, Johnston FL, et al. 1996. Burning radionuclide question: What happens to iodine, cesium and chlorine in biomass fires? *Sci Total Environ* 187:93-103.
- Ammerman CB, Miller SM, Fick KR, et al. 1977. Contaminating elements in mineral supplements and their potential toxicity: A review. *J Anim Sci* 44(3):485-538.
- Amphoux-Fazekas T, Samih N, Hovsepian S, et al. 1998. DIDS (4,4'-diisothiocyanatostilbene-2,2'-disulfonic acid) increases iodide trapping, inhibits thyroperoxidase and antagonizes the TSH-induced apical iodide efflux in porcine thyroid cells. *Mol Cell Endocrinol* 141:129-140.
- Amvosiev AP, Banetskaya NY. 1992. [Early and long-term effects of the combined action of iodine-131 and cesium-137 at low doses on ovaries of animals.] *Dokl Akad Nauk Belarusi* 36(9-10):855-858. (Russian)
- Amvos'ev AP, Vereshchako GG, Redrov AG. 1991. [Analysis of the effect of iodine-131 on the cytochemical activity of peripheral blood lymphocyte hydroxyreductases in rats.] *Gig Sanit* 7:53-55. (Russian)
- Anders E. 1962. Minimal dosage of iodide required to suppress uptake of iodine-131 by normal thyroid. *Science* 138:430-433.
- *Andersen ME, Krishnan K. 1994. Relating in vitro to in vivo exposures with physiologically based tissue dosimetry and tissue response models. In: Salem H, ed. *Animal test alternatives: Refinement, reduction, replacement*. New York: Marcel Dekker, Inc., 9-25.
- *Andersen ME, Clewell HJ III, Gargas ML, et al. 1987. Physiologically based pharmacokinetics and the risk assessment process for methylene chloride. *Toxicol Appl Pharmacol* 87:185-205.
- *Anderson TJ. 1978. Methodology for the determination of environmental ¹²⁹I and ⁹⁹Tc. Savannah River Laboratory, Aiken, SC. NTIS: DP-MS-77-75 (Conf 780719-2).
- Anderson GS, Bird T. 1961. Congenital iodide goitre in twins. *Lancet* 2:742-743.
- Anderson DM, Marsh TL, Deonigi DA. 1996. Developing historical food production and consumption data for ¹³¹I dose estimates: The Hanford experience. *Health Phys* 71(4):578-587.
- Anderson KA, Casey B, Diaz E, et al. 1996. Speciation and determination of dissolved iodide and iodine in environmental aqueous samples by inductively coupled plasma atomic emission spectrometry. *J AOAC Int* 79(3):751-756.
- Anderson LL, Lau CC, Gracely EJ, et al. 1997. Enhancement of ¹³¹I-mediated cytotoxicity by caffeine. *Gynecol Oncol* 65:253-257.
- *Anderson DM, Marsh TL, Deonigi DA. 1996. Developing historical food production and consumption data for ¹³¹I dose estimates: The Hanford experience. *Health Physics* 71:578-587.
- *Andersson S, Forsman U. 1997. Determination of total iodine in biological material by alkaline ashing and column-switching ion-pair liquid chromatography. *J Chromatogr B Biomed Appl* 692:53-59.
- Andreyeva LP, Shvedov VL. 1977. [Changes in the rat hemopoietic system when exposed to Strontium 89 and Iodine 131 simultaneously.] *Radiobiologiya* 17(5):752-757. (Russian)

9. REFERENCES

- *Andros G, Wollman SH. 1991. Kinetics of equilibration of radionuclide in individual mouse thyroid follicles in vivo. *Am J Physiol* 261(24):E529-E538.
- Anno Y, Sasaki T, Takeshita A, et al. 1975. Incidence of hypothyroidism after radioiodine treatment of hyperthyroidism: A report of the radioiodine therapy follow-up study. *Nippon Igaku Hoshasen Gakkai Zasshi* 35(7):545-555.
- Anokhin IN, Norets TA. 1986. [Disorders of immunologic homeostasis as affected by radioactive iodine preparation.] *Med Radiol* 31(11):55-58. (Russian)
- Anonymous. 1980. Radioactive iodine and the risk of malignant thyroid tumour. *N Z Med J* 92:386-387.
- Anonymous. 1987. Studies evaluate medical responses to nuclear accidents, question use of potassium iodide. *Am J Hosp Pharm* 44:2651-2652.
- Anonymous. 1991. Nuclear accident countermeasures: Iodine prophylaxis. *Rep Health Soc Subj (Lond)* 39:1-63.
- Anonymous. 1994. Comparison of radionuclide levels in soil, sagebrush, plant litter, cryptogams, and small mammals. Westinghouse Hanford Co., Richland, WA. NTIS DE95001629.
- Anonymous. 1997. Chemical mixture. *Environ Health Perspect Suppl* 105(1):371-372.
- Ansell JE. 1996a. The blood in hypothyroidism. In: Braverman LE, Utiger RD, eds. *Werner and Ingbar's the thyroid: A fundamental and clinical text*. Philadelphia, PA: Lippincott-Raven, 821-825.
- Ansell JE. 1996b. The blood in thyrotoxicosis. In: Braverman LE, Utiger RD, eds. *Werner and Ingbar's the thyroid: A fundamental and clinical text*. Philadelphia, PA: Lippincott-Raven, 637-644.
- *AOAC. 1984. Official methods of analysis, 14th ed. Association of Official Analytical Chemists. Arlington, VA.
- APHS. 1998. Standard methods for the examination of water and waste water, 20th ed. American Public Health Association. Washington, DC.
- Appell R, Tsangaris N, Spiegel J. 1978. Radioiodine treated hyperthyroidism and thyroid carcinoma. *Am Surg* 44:537-540.
- *Ardito G, Lamberti L, Bigatti P, et al. 1987. Comparison of chromosome aberration frequency before and after administration of ¹³¹I in two groups of thyroid cancer patients. *Tumori* 73:257-262.
- Ardito G, Lamberti L, Bigatti MP. 1988. Chromosome studies on human lymphocytes following treatment with radioactive iodine in vitro. *Boll Soc Ital Biol Sper* 2(LXIV):131-138.
- Ardito G, Lamberti L, Cottino F, et al. 1983. Analysis of cell kinetics, chromosome aberration frequency and sister chromatid exchanges in lymphocyte "in vitro" cultures of patients irradiated by ¹³¹I. Preliminary note. *Boll Soc Ital Biol Sper* 59(2):135-141.
- Arena Ansotegui J, Empananza Knorr JI, San Millan Vege MJ, et al. 1989. [Iodine overload in newborn infants caused by the use of PVP-iodine for perineal preparation of the mother in vaginal delivery.] *An Esp Pediatr* 30(1):23-26. (Spanish)
- Arndt D, Mehnert WH, Franke W-G, et al. 1994. Radioiodine therapy during an unknown remained pregnancy and radiation exposure of the fetus. *Strahlenther Onkol* 170(7):408-414.

9. REFERENCES

- Arrington LR, Taylor RN, Ammerman CB, et al. 1965. Effects of excess dietary iodine upon rabbits, hamsters, rats and swine. *J Nutr* 87:394-398.
- Arslan NC, Geard CR, Hall EJ. 1986. Low dose-rate effects of cesium-137 and iodine-125 on cell survival, cell progression, and chromosomal alterations. *Am J Clin Oncol* 9(2):114-115.
- Artemova EP, Nikolaev AI. 1976. [Congenital disorders of the thyroid gland in experimental litters obtained from mothers subjected to immunization and the action of I-131.] *Probl Endokrinol (Mosk)* 22(2):66-70. (Russian)
- Arthur JR. 1999. Functional indicators of iodine and selenium status. *Proc Nutr Soc* 58:507-512.
- *Arthur JR, Beckett GF. 1994. Roles of selenium in Type I iodothyronine 5'-deiodinase and in thyroid hormone and iodine metabolism. In: Burk RF, ed. *Selenium in biology and human health*. New York, NY: Springer-Verlag, 94-115.
- Arthur JR, Nicol F, Beckett GJ. 1992a. The role of selenium in thyroid hormone metabolism and effects of selenium deficiency on thyroid hormone and iodine metabolism. *Biol Trace Elem Res* 34:321-325.
- Arthur JR, Nicol F, Beckett GJ. 1992b. The role of selenium in thyroid hormone metabolism and effects of selenium on thyroid hormone and iodine metabolism. *Biol Trace Elem Res* 33:37-42.
- Asmis LM, Gerber H, Kaempf J, et al. 1995. Epidermal growth factor stimulates cell proliferation and inhibits iodide uptake of FRTL-5 cells *in vitro*. *J Endocrinol* 145:513-520.
- Assimakopoulos PA, Ioannides KG, Pakou AA, et al. 1987. Transport of the radioisotopes iodine-131, cesium-134, and cesium-137 from the fallout following the accident at the Chernobyl nuclear reactor into cheese and other cheesemaking products. *J Dairy Sci* 70:1338-1343.
- Assimakopoulos PA, Ioannides KG, Pakou AA. 1988. The environmental behavior of ¹³¹I in northwestern Greece following the nuclear reactor accident at Chernobyl. *Health Phys* 55(5):783-791.
- Assimakopoulos PA, Ioannides KG, Pakou AA. 1989. The propagation of the Chernobyl ¹³¹I impulse through the air-grass-animal-milk pathway in northwestern Greece. *Sci Total Environ* 85:295-305.
- *Astakhova LN, Anspaugh LR, Beebe GW, et al. 1998. Chernobyl-related thyroid cancer in children in Belarus: A case-control study. *Rad Res* 150:349-356.
- *Astakhova LN, Mityukova TA, Kobzev VF. 1996. Endemic goiter in Belarus following the accident at the Chernobyl nuclear power plant. In: Nagasaki S, Yamashita S, eds. *Nagasaki symposium radiation and human health: Proposal from Nagasaki*. Amsterdam, the Netherlands: Elsevier, 67-95.
- *ASTM. 1995. *Annual book of ASTM Standards*. vol. 11.02. American Society for Testing of Materials. Philadelphia, PA.
- *ASTM. 1998. American Society for Testing and Materials. Standard test methods for iodide and bromide ions in brackish water, seawater, and brines. NTIS ASTM-D 3869-95.
- ASTM. 1999. *Annual book of ASTM standards*, vol. 11.02. American Society for Testing of Materials. Philadelphia, PA: ASTM, 290-300.
- *ATF. 2001a. Denaturants authorized for denatured spirits. U.S. Bureau of Alcohol, Tobacco, and Firearms. Code of Federal Regulations. 27 CFR 21.151. <http://frwebgate.access.gpo.gov/cgi-bin/...&PART=21&SECTION=151&YEAR=2000&TYPE=TEXT>. May 16, 2001.

9. REFERENCES

- *ATF. 2001b. Uses of specially denatured alcohol and specially denatured rum. U.S. Bureau of Alcohol, Tobacco, and Firearms. Code of Federal Regulations. 27 CFR 21.141. <http://frwebgate.access.gpo.gov/cgi-bin/...&PART=21&SECTION=141&YEAR=2000&TYPE=TEXT>. Nat 16m 2001.
- *ATSDR. 1989. Agency for Toxic Substances and Disease Registry. Decision guide for identifying substance-specific data needs related to toxicological profiles; Notice. Federal Register 54(174):37618-37634.
- *ATSDR. 1990. Biomarkers of organ damage or dysfunction for the renal, hepatobiliary, and immune systems. Subcommittee on Biomarkers of Organ Damage and Dysfunction, Agency for Toxic Substances and Disease Registry, Atlanta, GA.
- *ATSDR. 1997. Toxicological Profile for Cyanide (Update). U.S. Department of Health and Human Services. Public Health Service. Agency for Toxic Substances and Disease Registry.
- *ATSDR. 1999. Toxicological profile for ionizing radiation. Agency for Toxic Substances and Disease Registry, Atlanta, GA.
- *ATSDR. 2000. Toxicological profile for polychlorinated biphenyls. Agency for Toxic Substances and Disease Registry, Atlanta, GA.
- Aungst BJ, Vesell ES, Shapiro JR. 1979. Unusual characteristics of the dose-dependent uptake of propylthiouracil by thyroid gland *in vivo*: Effects of thyrotropin, iodide or phenobarbital pretreatment. *Biochem Pharmacol* 28:1479-1484.
- Austin AR, Whitehead DC, Le Du YLP, et al. 1980. The influence of dietary iodine on iodine in the blood serum of cows and calves in the perinatal period. *Res Vet Sci* 28:128-130.
- Ayala C, Navarro E, Rodriguez JR, et al. 1998. Conception after iodine-131 therapy for differentiated thyroid cancer. *Thyroid* 8(11):1009-1011.
- Ayromlooi J. 1972. Congenital goiter due to maternal ingestion of iodides. *Obstet Gynecol* 39(6):818-822.
- Babu S, Shenolikar I. 1992. Thiocyanate ingestion through milk and its effects on serum triiodothyronine (T₃) and thyroxine (T₄) levels in monkeys fed low iodine diet. *Indian J Dairy Sci* 45(6):326-329.
- *Bacher-Stier C, Riccabona G, Totsch M, et al. 1997. Incidence and clinical characteristics of thyroid carcinoma after iodine prophylaxis in an endemic goiter country. *Thyroid* 7(5):733-741.
- *Bachrach LK, Burrow GN, Gare DJ. 1984. Maternal-fetal absorption of povidone-iodine. *J Pediatr* 104(1):158-159.
- Bagchi N, Brown TR. 1986. Adaptation of male and female rats to iodine deficiency. *Horm Metab Res* 18:811-813.
- *Bagchi N, Fawcett DM. 1973. Role of sodium ion in active transport of iodide by cultured thyroid cells. *Biochim Biophys Acta* 318:235-251.
- Bagchi N, Brown TR, Urdanivia E, et al. 1985a. Induction of autoimmune thyroiditis in chickens by dietary iodine. *Science* 230:325-327.
- Bagchi N, Shivers B, Brown TR. 1985b. Studies on the mechanism of acute inhibition of thyroglobulin hydrolysis by iodine. *Acta Endocrinol* 108:511-517.

9. REFERENCES

- *Bair WJ, Snyder MD, Walters RA, et al. 1963. Effect of I¹²⁷ on thyroid uptake of inhaled I¹³¹. *Health Phys* 9:1399-1410.
- Bairakova A, Nikolova M, Kiradzhiev G. 1990. [Side-effects of iodine prophylaxis in pregnancy.] *Rentgenol Radiol* 29(2):46-50. (Russian)
- Baker HJ, Lindsey JR. 1968. Equine goiter due to excess dietary iodide. *J Am Vet Med Assoc* 153(12):1618-1630.
- *Bakheet SMB, Hammami MM, Hemidan A, et al. 1998. Radioiodine secretion in tears. *J Nucl Med* 39(8):1452-1454.
- Bakheet SMB, Hammami MM, Powe J. 1996. False-positive radioiodine uptake in the abdomen and the pelvis: Radioiodine retention in the kidneys and review of the literature. *Clin Nucl Med* 21(12):932-937.
- *Bakiri F, Djemli FK, Mokrane LA, et al. 1998. The relative roles of endemic goiter and socioeconomic developmental status in the prognosis of thyroid carcinoma. *Cancer* 82:1146-1153.
- Bal CS, Padhy AK, Jana S, et al. 1994. Comparison of low and high dose I-131 ablation of remnant in differentiated thyroid cancer patients. In: *Proceedings of the XVI International Cancer Congress: Free papers and posters: New Delhi (India), October 30-November 5, 1994. Bologna, Italy: Monduzzi Editore, 1059-1063.*
- Bal C, Padhy AK, Jana S, et al. 1996. Prospective randomized clinical trial to evaluate the optimal dose of ¹³¹I for remnant ablation in patients with differentiated thyroid carcinoma. *Cancer* 77:2574-2580.
- Ball DW, Baylin SB, de Bustros AC. 1996. Medullary thyroid carcinoma. In: Braverman LE, Utiger RD, eds. *Werner and Ingbar's the thyroid: A fundamental and clinical text. Philadelphia, PA: Lippincott-Raven, 946-960.*
- *Ballad RV, Holman DW, Hennecke EW, et al. 1976. Iodine-129 in thyroids of grazing animals. *Health Phys* 30:345-350.
- *Ballad RV, Tan SH, Johnson JE, et al. 1978. Iodine-129 in man, cow and deer. *Health Phys* 34:691-696.
- Balsam A, Sexton F, Borges M, et al. 1983. Formation of diiodotyrosine from thyroxine. *J Clin Invest* 72:1234-1245.
- Balter M. 1995. Chernobyl's thyroid cancer toll. *Science* 270:1758-1759.
- *Baltisberger BL, Minder CE, Burgi H. 1995. Decrease of incidence of toxic nodular goitre in a region of Switzerland after full correction of mild iodine deficiency. *Eur J Endocrinol* 132:546-549.
- Baltrukiewicz Z, Derecki J, Pogorzelska-Lis M. 1973. Transfer of selected radionuclides from the organism of pregnant and feeding female rat to the offsprings. *Acta Physiol Pol* 24:437-444.
- Banerjee R, Gopinath G, Gopinath PG. 1988. Vascular changes in the brain following internally administered radioisotope ¹³¹I in rats during postnatal period. *Indian J Med Res* 87:484-493.
- Banfield WG, Grimley PM, Hammond WG, et al. 1971. Electron probe analysis for iodine in human thyroid and parathyroid glands, normal and neoplastic. *J Natl Cancer Inst* 46:269-273.
- Bangming R, Jianguo L, Xianyu C, et al. 1996. [Study of thyroglobulin gene activity in thyroid disease.] *Zhonghua Heyixue Zazhi* 16(4):250-252. (Chinese)

9. REFERENCES

- *Barakat M, Carson D, Hetherington AM, et al. 1994. Hypothyroidism secondary to topical iodine treatment in infants with spina bifida. *Acta Paediatr* 83:741-743.
- Baran DT. 1996a. The skeletal system in hypothyroidism. In: Braverman LE, Utiger RD, eds. *Werner and Ingbar's the thyroid: A fundamental and clinical text*. Philadelphia, PA: Lippincott-Raven, 853-857.
- Baran DT. 1996b. The skeletal system in thyrotoxicosis. In: Braverman LE, Utiger RD, eds. *Werner and Ingbar's the thyroid: A fundamental and clinical text*. Philadelphia, PA: Lippincott-Raven, 678-686.
- *Baratta EJ, Esterly DG. 1989. Gamma-ray spectroscopic determination of iodine-131 and cesium-137 in foods: Two collaborative studies. *J Assoc Off Anal Chem* 72(4):667-669.
- *Barker SB. 1948. Determination of protein-bound iodine. *J Biol Chem* 173:715-724.
- *Barkley RA, Thompson TG. 1960. Determination of chemically combined iodine in sea water by amperometric and catalytic methods. *Anal Chem* 32:154-158.
- *Barnes DG, Dourson M. 1988. Reference dose (RfD): Description and use in health risk assessments. *Regul Toxicol Pharmacol* 8:471-486.
- Barnes ND, O'Connell EJ, Cloutier MD. 1975. Iodide-induced (SSKI) hypothyroidism in infancy. *Ann Allergy* 35:305-308.
- *Barrie LA, Hoff RM. 1985. Five years of air chemistry observations in the Canadian Arctic. *Atmos Environ* 19:1995-2010.
- Barrington SF, Kettle AG, O'Doherty MJ, et al. 1996. Radiation dose rates from patients receiving iodine-131 therapy for carcinoma of the thyroid. *Eur J Nucl Med* 23(2):123-130.
- *Barrington SF, O'Doherty MJ, Kettle AG, et al. 1999. Radiation exposure of the families of outpatients treated with radioiodine (iodine-131) for hyperthyroidism. *Eur J Nucl Med* 26(7):686-692.
- Barsano CP. 1996. Other forms of hypothyroidism. In: Braverman LE, Utiger RD, eds. *Werner and Ingbar's the thyroid: A fundamental and clinical text*. Philadelphia, PA: Lippincott-Raven, 768-778.
- Bartalena L, Bogazzi F, Martino E. 1996. Adverse effects of thyroid hormone preparations and antithyroid drugs. *Drug Saf* 15:53-63.
- Bartalena L, Marcocci C, Bogazzi F, et al. 1989. Use of corticosteroids to prevent progression of Graves' ophthalmopathy after radioiodine therapy for hyperthyroidism. *N Engl J Med* 321(20):1349-1352.
- Bartalena L, Marcocci C, Bogazzi F, et al. 1998. Relation between therapy for hyperthyroidism and the course of Graves' ophthalmopathy. *N Engl J Med* 338(2):73-78.
- *Bartolini P, Ribela MTCP, Araujo EA. 1988. Results of a thyroid monitoring survey carried out on workers exposed to ¹²⁵I in Sao Paulo, Brazil. *Health Phys* 55(3):511-515.
- *Bašić M, Kasal B, Simonovic I, et al. 1988. ¹³¹I dose to the human fetal thyroid in the Zagreb district, Yugoslavia, from the Chernobyl accident. *Int J Radiat Biol* 54(2):167-177.
- Bastiani P, Papandreou J, Blanck O, et al. 1995. On the relationship between completion of *N*-acetyllactosamine oligosaccharide units and iodine content of thyroglobulin: A reinvestigation. *Endocrinology* 136(10):4204-4209.
- *Baugnet-Mahieu L, Lemaire M, Leonard ED, et al. 1994. Chromosome aberrations after treatment with radioactive iodine for thyroid cancer. *Radiat Res* 140:429-431.

9. REFERENCES

- *Baumgartner TG. 1976. Potassium iodide and iododerma. *Am J Hosp Pharm* 33:601-603.
- Bautista A, Barker PA, Dunn JT, et al. 1982. The effects of oral iodized oil on intelligence, thyroid status, and somatic growth in school-age children from an area of endemic goiter. *Am J Clin Nutr* 35:127-134.
- Baverstock KF. 1993. Thyroid cancer in children in Belarus after Chernobyl. *World Health Stat Q* 46:204-208.
- Bayliff CD, Sibbald WJ, Mills DG, et al. 1981. Electrolyte abnormalities following povidone-iodine topical therapy. *Drug Intell Clin Pharm* 15(10):801-802.
- Bazyltchik SV, Astakhova LN. 1996. Mental development of children exposed to ionizing radiation in utero and in infancy. In: Nagataki S, Yamashita S, eds. *Nagasaki symposium radiation and human health: Proposal from Nagasaki*. Amsterdam, the Netherlands: Elsevier, 97-102.
- Beach SA, Dolphin GW. 1962. A study of the relationship between x-ray dose delivered to the thyroids of children and the subsequent development of malignant tumours. *Phys Med Biol* 6:583-598.
- *Beals DM, Chastagner P, Turner P. 1992. Analysis of iodine-129 in aqueous samples by inductively coupled plasma-mass spectrometry. Westinghouse Savannah River Company, Aiken, SC. NTIS: DE93002694.
- *Beals DM, Hayes DW. 1995. Technetium-99, iodine-129 and tritium in the waters of the Savannah river site. *Sci Total Environ* 173/174:101-115.
- Beaugelin-Seiller K, Baudin JP, Brottet D. 1994. Use of aquatic mosses for monitoring artificial radionuclides downstream of the nuclear power plant of Bugey (River Rhone, France). *J Environ Radioact* 24:217-223.
- Becciolini A, Porciani S, Lanini A, et al. 1994. Serum amylase and tissue polypeptide antigen as biochemical indicators of salivary gland injury during iodine-131 therapy. *Eur J Nucl Med* 21:1121-1125.
- Bech K. 1988. Importance of cytolytic activity and dietary iodine in the pathogenesis of postpartum thyroiditis. *Allergy* 43:161-166.
- Becker B. 1961. Iodide transport by the rabbit eye. *Am J Physiol* 200(4):804-806.
- Becker BA, Fenves AZ, Breslau NA. 1999. Membranous glomerulonephritis associated with Grave's disease. *Am J Kidney Dis* 33(2):369-373.
- Becker DV. 1979. The role of radioiodine treatment in childhood hyperthyroidism. *J Nucl Med* 20(8):890-894.
- Becker DV. 1983. Physiological basis for the use of potassium iodide as a thyroid blocking agent logistic issues in its distribution. *Bull N Y Acad Med* 59(10):1003-1008.
- Becker DV. 1987. Reactor accidents: Public health strategies and their medical implications. *JAMA* 258:649-654.
- Becker DV, Zanzonico P. 1997. Potassium iodide for thyroid blockade in a reactor accident: Administrative policies that govern its use. *Thyroid* 7(2):193-197.
- Becker DV, Braverman LE, Dunn JT, et al. 1984. The use of iodine as a thyroidal blocking agent in the event of a reactor accident: Report of the Environmental Hazards Committee of the American Thyroid Association. *JAMA* 252(5):659-661.

9. REFERENCES

- Becker PC, Ibanez CA, Aguayo JB, et al. 1986. [Absence of foetal hypothyroidism despite treatment with ^{131}I during gestation.] *Rev Med Chil* 114:343-345. (Spanish)
- Becker W, Borner W, Reiners C, et al. 1988. [Radioiodine therapy for immune hyperthyroidism depending on age. A tenable risk even for younger patients?]. *Dtsch Med Wochenschr* 113(23):954-961. (German)
- Beckham W, Ralson A. 1991. Letters to the editor. *Australas Phys Eng Sci Med* 14(3):173.
- Becks GP, Eggo MC, Burrow GN. 1987. Regulation of differentiated thyroid function by iodide: Preferential inhibitory effect of excess iodide on thyroid hormone secretion in sheep thyroid cell cultures. *Endocrinology* 120(6):2569-2575.
- Bednar J, Nemeč J, Soutorova M, et al. 1980. Composition of circulating iodoproteins following therapeutic application of ^{131}I for thyroid carcinoma. *Radiochem Radioanal Lett* 45(6):377-386.
- Bednarczuk T, Kennerdell JS, Wall JR. 1997. Thyroid-associated ophthalmopathy: Etiology and pathogenesis. In: Falk SA, ed. *Thyroid disease: Endocrinology, surgery, nuclear medicine, and radiotherapy*. Philadelphia, PA: Lippincott-Raven Publishers, 341-357.
- Beekhuis H, Piers DA. 1983. Radiation risk of thyroid scintigraphy in newborns. *Eur J Nucl Med* 8:348-350.
- Beere HM, Bidey SP, Tomlinson S. 1989. Cytotoxicity of high iodide levels for porcine thyroid cells in primary culture is relieved by methimazole or stable cyclic AMP analogues. *J Endocrinol* 121(Suppl):No pagination.
- Beere HM, Cowin AJ, Soden J, et al. 1995. Iodide-dependent regulation of thyroid follicular cell proliferation: A mediating role of autocrine insulin-like growth factor-I. *Growth Regul* 5:203-209.
- Beere HM, Tomlinson S, Bidey SP. 1990. Iodide autoregulation of functional and morphological differentiation events in the FRTL-5 rat thyroid cell strain. *J Endocrinol* 124:19-25.
- Beeson KC, Forbes AL, Horvath DJ, et al. 1978. Plants and foods of plant origin. In: *Geochemistry and the environment*. Vol. III. Distribution of trace elements related to the occurrence of certain cancers, cardiovascular diseases and urolithiasis. Washington, DC: National Academy of Sciences, 59-78.
- Beeson PB. 1994. Effects of iodides on inflammatory processes. *Perspect Biol Med* 37(2):173-181.
- Begishev A. 1975. [Data on the toxicity characteristics of iodine vapors under conditions of increased air temperature (experimental data).] *Gig Tr Prof Zabol* 6:38-41. (Russian)
- *Behne D, Kyriakopoulos A. 1993. Effects of dietary selenium on the tissue concentrations of type I iodothyronine 5'-deiodinase and other selenoproteins. *Am J Clin Nutr Suppl* 57:310S-312S.
- *Beierwaltes WH. 1979. The history of the use of radioactive iodine. *Semin Nucl Med* IX(3):151-155.
- Beierwaltes WH, Crane HR, Wegst A, et al. 1960. Radioactive iodine concentration in the fetal human thyroid gland from fall-out. *JAMA* 173(17):1895-1902.
- *Beierwaltes WH, Hilger MTJ, Wegst A. 1963. Radioiodine concentration in fetal human thyroid from fallout. *Health Phys* 9:1263-1266.
- BEIR V. 1990. Health effects of exposure to low levels of ionizing radiation. *Biological Effects of Ionizing Radiations*. Washington, DC: National Academy Press.

9. REFERENCES

- *Belfiore A, La Rosa GL, Padova G, et al. 1987. The frequency of cold thyroid nodules and thyroid malignancies in patients from an iodine-deficient area. *Cancer* 60:3096-3102.
- Bellisola G, Bratter P, Cinque G, et al. 1998. The TSH-dependent variation of the essential elements iodine, selenium and zinc within human thyroid tissues. *J Trace Elem Med Biol* 12:177-182.
- *Beno M, Hrabovcova A, Piknova D, et al. 1991. Human postmortem thyroid ¹³¹I content and risk estimates in Bratislava, Czechoslovakia following the Chernobyl accident. *Health Phys* 60(2):203-208.
- *Beno M, Mikulecky M, Hrabina J. 1992. Transfer factor of ¹³¹I from the fallout to human thyroid dose equivalent after the Chernobyl accident. *Radiat Environ Biophys* 31:133-139.
- *Benotti J, Benotti N. 1963. Protein-bound iodine, total iodine and butanol-extractable iodine by partial automation. *Clin Chem* 9:408-416.
- *Benotti J, Benotti N, Pino S, et al. 1965. Determination of total iodine in urine, stool, diets and tissues. *Clin Chem* 11:932-936.
- Benson SG. (1969). Kinetics of I¹³¹ uptake and release in the rat thyroid gland. Ph.D. Dissertation, The University of Nebraska. 70 p.
- Bercz JP. 1991. Endocrine toxicity of drinking water disinfectants. I. *In vivo* dehalogenation and clearance of iodinated nutrients. *J Am Coll Toxicol* 10(5):525-532.
- Bercz JP, Jones LL, Harrington RM, et al. 1986. Mechanistic aspects of ingested chlorine dioxide on thyroid function: Impact of oxidants on iodide metabolism. *Environ Health Perspect* 69:249-255.
- Berenbaum MC. 1974. The production of pulmonary oedema in mice by cyclophosphamide and iodide. *Agents Actions* 4(1):7-14.
- Beresford NA, Mayes RW, Barnett CL, et al. 1997. The effectiveness of oral administration of potassium iodide to lactating goats in reducing the transfer of radioiodine to milk. *J Environ Radioact* 35(2):115-128.
- *Berg D, Kollmer WE, Kriegel H, et al. 1987. Radioactive iodine and cesium in Bavarian citizens after the nuclear reactor accident in Chernobyl. *Trace Subst Environ Health* 21:219-225.
- Berg GEB, Michanek AMK, Holmberg ECV, et al. 1996. Iodine-131 treatment of hyperthyroidism: Significance of effective half-life measurements. *J Nucl Med* 37(2):229-232.
- Berg GEB, Nystrom EH, Jacobsson L, et al. 1998. Radioiodine treatment of hyperthyroidism in a pregnant woman. *J Nucl Med* 39:357-361.
- Berg JN, Padgett D. 1985. Iodine concentrations in milk from iodophor test dips. *J Dairy Sci* 68:457-461.
- *Berger GS. 1994. Epidemiology of endometriosis. In: Berger GS, ed. *Endometriosis: Advanced management and surgical techniques*. New York, NY: Springer-Verlag.
- *Bermejo-Barrera P, Moreda-Pineiro A, Aboal-Somoza M, et al. 1994. Indirect determination of iodide, as an Hg_xI_x complex, by electrothermal atomic absorption spectrometry. *J Anal Atom Spectrom* 9:483-487.
- *Bernard JD, McDonald RA, Nesmith JA. 1970. New normal ranges for the radioiodine uptake study. *J Nucl Med* 11:449-451.

9. REFERENCES

Bernhard JD, Freedberg IM, Vogel LN. 1996a. The skin in hypothyroidism. In: Braverman LE, Utiger RD, eds. *Werner and Ingbar's the thyroid: A fundamental and clinical text*. Philadelphia, PA: Lippincott-Raven, 792-795.

Bernhard JD, Freedberg IM, Vogel LN. 1996b. The skin in thyrotoxicosis. In: Braverman LE, Utiger RD, eds. *Werner and Ingbar's the thyroid: A fundamental and clinical text*. Philadelphia, PA: Lippincott-Raven, 595-597.

*Bertelsen JB, Hegedus L. 1994. Cigarette smoking and the thyroid. *Thyroid* 4:327.

Berthezene F, Greer MA. 1974. Studies on the composition of the thyroid psammoma bodies of chronically iodine-deficient rats. *Endocrinology* 95:651-659.

Berthezene F, Mornex R. 1971. Variations chez le rat de la clearance thyroïdienne de l'iode (CIT), du taux d'iodure plasmatique (PII) et de la captation absolue de l'iode stable (AUI) apres l'arret d'un traitement par le methylthiouracil (MTU). *Pathol Biol* 23-24:1075-1079.

Berthier C, Lemarchand-Beraud T. 1976. Thyroid cAMP and iodine, plasma and pituitary TSH during goiter development in rats. *Excerpta Medica* 378:485-489.

Berthier C, Lemarchand-Beraud T. 1978. Importance of thyroid iodine and cyclic AMP and TSH concentrations on goitre formation in rats. *Acta Endocrinol* 89:567-579.

Bertin M, Lallemand J, Hubert D. 1994. [Health consequences of a Chernobyl accident. An assessment eight years later.] *Lyon Pharm* 45(1):9-16. (French)

*Bertine KK, Goldberg ED. 1971. Fossil fuel combustion and the major sedimentary cycle. *Science* 173:233-235.

Best JD, Chan V, Khoo R, et al. 1981. Incidence of hypothyroidism after radioactive iodine therapy for thyrotoxicosis in Hong Kong Chinese. *Clin Radiol* 32:57-61.

Bestano M, Pagliaini R, Maira G, et al. 1993. Mediastinal uptake of ¹³¹I in patients with thyroid cancer: May it be referred to normal thymus? *Eur J Nucl Med* 20:648.

Bethell MF. 1970. Toxic psychosis caused by radioactive iodine [Letter]. *Br J Psychiatry* 117:473-479.

*Better OS, Garty J, Brautbar N, et al. 1969. Diminished functional parathyroid reserver following I¹³¹ treatment for hyperthyroidism. *Isr J Med Sci* 5(3):419-422.

*Beyer KH, Fehr DM, Gelarden RT, et al. 1981. Hydrochlorothiazide-induced ¹³¹I excretion facilitated by salt and water. *J Clin Pharmacol* 21(5-6):201-212.

Beysen ML, Lagorce JF, Cledat D, et al. 1999. Influence of dietary iodine on drug-induced hypothyroidism in the rat. *J Pharm Pharmacol* 51:745-750.

Bhat IS, Kamath PR. 1969. Goat thyroids as indicators for routine environmental monitoring of radioiodine. *Health Phys* 16:65-67.

*Bhat IS, Hedge AG, Chandramouli S, et al. 1973. Evaluation of internal exposure to radionuclides of I, Cs, and Co during maintenance operations on primary steam leak in a nuclear power station. *Health Physics* 25:135-139.

Bhatt H. 1977. Effect of calcium intake on thyroid and renal clearance of iodine in goiter. *J Physiol* 269:64-65.

9. REFERENCES

- Bhatta KM, Evenstad KL. 1994. Use of potassium iodide for the treatment of symptomatic benign hyperplasia. (to Upsher-Smith Laboratories) Application: USA WO 94/25040, 10 Nov 1994. USA Patent WO 94/25040, issued 10 Nov 1994.
- Bianco AC, Nunes MT, Martins EJ, et al. 1981. Possible mechanism of action of cholesterol enriched diet on the thyroid. *Endocrinol Exp* 15:277-285.
- Birnbaum DA. 1978. Febrile response to whirlpool bath treatments [Letter]. *JAMA* 239(12):1133.
- Bishop ME, Garcia RL. 1978. Iododerma from wound irrigation with povidone-iodine. *JAMA* 240(3):249-250.
- Bitton R, Sachmechi I, Benegalro Y, et al. 1993. Leukemia after a small dose of radioiodine for metastatic thyroid cancer. *J Clin Endocrinol Metab* 77(5):1423-1426.
- *Black A, Hounam RF. 1968. Penetration of iodine vapour through the nose and mouth and the clearance and metabolism of the deposited iodine. *Ann Occup Hyg* 11:209-225.
- Black JA. 1963. Neonatal goitre and mental deficiency: The role of iodides taken during pregnancy. *Arch Dis Child* 38:526-529.
- *Black SC, Douglas RL, Barth DS. 1976. Gaseous radioiodine transport in the air-forage-cow-milk system. US Environmental Protection Agency, Las Vegas, NV. Report No. EMLS-LV-539-1, 1-25.
- Blackwell N, Stevenson AC, Wiernik G. 1974. Chromosomal findings in patients treated with small doses of iodine-131. *Mutat Res* 25:397-402.
- Blahos J, Soumar J. 1973. [Increased frequency of hypothyroidism after iodine 131. Longitudinal study.] *Probl Acutels Endocrinol Nutr* 17:95-103. (French)
- Blahos J, Soumar J. 1975. The role of age in the development of hypothyroidism after treatment with radioiodine. *Endokrinologie* 64(2):196-200.
- *Bleuer JP, Averkin YI, Abelin T. 1997. Chernobyl-related thyroid cancer: What evidence for role of short-lived iodines? *Environ Health Perspect Suppl* 105(6):1483-1486.
- Blincoe C, Bohman VR. 1991. Fallout ¹³¹I in western Nevada cattle thyroid glands: 1962-Early 1969. *Bull Environ Contam Toxicol* 47:485-490.
- Blomgren H, Wasserman J, Petrini B, et al. 1991. Blood lymphocyte population following ¹³¹I treatment for hyperthyroid. *Acta Endocrinol* 124:152-158.
- Bloomer WD, Adelstein SJ. 1981. Iodine-125 cytotoxicity: Implications for therapy and estimation of radiation risk. *Int J Nucl Med Biol* 8:171-178.
- Bloomer WD, McLaughlin WH, Adelstein SJ. 1982. Therapeutic implications of iodine-125 cytotoxicity. *Int J Radiat Oncol Biol Phys* 8:1903-1908.
- *Blum M, Liuzzi A. 1967. Thyroid ¹³¹I burdens in medical and paramedical personnel. *JAMA* 200(11):184-186.
- Blumenthal RD, Alisauskas R, Lew W, et al. 1998. Myelosuppressive changes from single or repeated doses of radioantibody therapy: effect of bone marrow transplantation, cytokines, and hematopoietic suppression. *Exp Hematol* 26:859-868.

9. REFERENCES

- Blumenthal RD, Sharkey RM, Quinn LM, et al. 1990. Use of hematopoietic growth factors to control myelosuppression caused by radioimmunotherapy. *Cancer Res Suppl*(50):1003s-1007s.
- *BNA. 2001f. Designation, reportable quantities, and notification. The Bureau of National Affairs, Inc. <http://www.bna.com/>. February 22, 2001.
- *BNA. 2001h. Environment and safety library: States and territories. The Bureau of National Affairs, Inc. <http://www.bna.com/>. February 13, 2001.
- *BNA. 2001b. General license for use of byproduct material for certain in vitro clinical or laboratory testing. The Bureau of National Affairs, Inc. <http://www.bna.com/>. February 22, 2001.
- *BNA. 2001g. Maximum groundwater contaminant levels. The Bureau of National Affairs, Inc. <http://www.bna.com/>. February 22, 2001.
- *BNA. 2001d. Quantities of licensed material requiring labeling. The Bureau of National Affairs, Inc. <http://www.bna.com/>. February 22, 2001.
- *BNA. 2001c. Quantities of radioactive materials requiring consideration of the need for an emergency plan for responding to a release. The Bureau of National Affairs, Inc. <http://www.bna.com/>. February 22, 2001.
- *BNA. 2001e. Release limits for containment requirements. The Bureau of National Affairs, Inc. <http://www.bna.com/>. February 22, 2001.
- *BNA. 2001a. Reports of individual monitoring. The Bureau of National Affairs, Inc. <http://www.bna.com/>. February 22, 2001.
- Bo G, Guishan Y. 1997. [Effects of high-dose iodine on brain development in mice.] *Chin J Prev Med* 31(3):134-136. (Chinese)
- Bobechko WP. 1989. Iodine in the diet. *Can Med Assoc J* 140:1431.
- Bocanera LV, Krawiec L, Silberschmidt D, et al. 1997. Role of cyclic 3'5'guanosine monophosphate and nitric oxide in the regulation of iodide. *J Endocrinol* 155:451-457.
- Bockisch A, Jamitzky T, Derwanz R, et al. 1993. Optimized dose planning of radioiodine therapy of benign thyroidal diseases. *J Nucl Med* 34(10):1632-1638.
- Bodansky HJ. 1986. Thyroid cancer after ¹³¹I treatment. *Lancet* 2(8509):755-756.
- *Bodigheimer K, Nowak F, Schoenborn W. 1979. Pharmacokinetics and thyrotoxicity of the sodium nitroprusside metabolite of thiocyanate. *Dtsch Med Wochenschr* 104:939-943.
- Body JJ, Demeester-Mirkine N, Corvilain J. 1988. Calcitonin deficiency after radioactive iodine treatment. *Ann Intern Med* 109(7):590-591.
- Boeynaems J-M, Van Sande J, Dumont JE. 1995. Which iodolipids are involved in thyroid autoregulation: Iodolactones or iodoaldehydes? *Eur J Endocrinol* 132:733-734.
- Bogazzi F, Bartalena L, Brogioni S, et al. 1999. Comparison of radioiodine with radioiodine plus lithium in the treatment of Graves' hyperthyroidism. *J Clin Endocrinol Metab* 84(2):499-503.
- *Bogdanove EM, Strash AM. 1975. Radioiodine escape is an unexpected source of radioimmunoassay error and chronic low level environmental contamination. *Nature* 257:426-427.

9. REFERENCES

- Bohuslavizki KH, Brenner W, Klutmann S, et al. 1998a. Radioprotection of salivary glands by amifostine in high-dose radioiodine therapy. *J Nucl Med* 39:1237-1242.
- *Bohuslavizki KH, Brenner W, Lassmann S, et al. 1996. Quantitative salivary gland scintigraphy in the diagnosis of parenchymal damage after treatment with radioiodine. *Nucl Med Commun* 17:681-686.
- *Bohuslavizki KH, Klutmann S, Bleckmann C, et al. 1999. Salivary gland protection by amifostine in high-dose radioiodine therapy by differentiated thyroid cancer. *Strahlenther Onkol* 175:57-61.
- *Bohuslavizki KH, Klutmann S, Brenner W, et al. 1998b. Salivary gland protection by amifostine in high-dose radioiodine treatment: Results of a double-blind placebo-controlled study. *J Clin Oncol* 16(11):3542-3549.
- Boice JD, Engholm G, Kleinerman RA, et al. 1988. Radiation dose and second cancer risk in patients treated for cancer of the cervix. *Radiat Res* 116:3-55.
- Bolster AA, Hilditch TE. 1996. The radiation dose to the urinary bladder in radio-iodine therapy. *Phys Med Biol* 41:1993-2008.
- Bonnema SJ, Bertelsen H, Mortensen J, et al. 1999. The feasibility of high dose iodine 131 treatment as an alternative to surgery in patients with a very large goiter: Effect on thyroid function and size and pulmonary function. *J Clin Endocrinol Metab* 84(10):3636-3641.
- Book DA, McNeill DA, Parks NJ, et al. 1980. Comparative effects of iodine-132 and iodine-131 in rat thyroid glands. *Radiat Res* 81:246-253.
- Book SA. 1977a. ¹³¹I uptake and retention in fetal guinea pigs. *Health Phys* 32:149-154.
- Book SA. 1977b. Iodine-129: Limits to radiologic dose. *Health Phys* 32(4):321-324.
- Book SA. 1983. Iodine-129 uptake and effects of lifetime feeding in rats. *Health Phys* 45(1):61-66.
- *Book SA, Goldman M. 1975. Thyroidal radioiodine exposure of the fetus. *Health Phys* 29:874-877.
- Book SA, McNeill DA, Spangler WL. 1980. Age and its influence on effects of iodine-131 in guinea pig thyroid glands. *Radiat Res* 81:254-261.
- Book SA, Wolf HG, Parker HR, et al. 1974. The exchange of radioiodine in pregnant and fetal sheep. *Health Phys* 26:533-539.
- Booz J, Smith T. 1977. Local distribution of energy deposition in and around the follicles of a ¹²⁵I contaminated thyroid. *Curr Top Radiat Res Q* 12:12-32.
- Bordell FL, Sayeg JA, Wald N, et al. 1972. *In vivo* measured effective half-life of ¹²⁵I in human thyroids. *Phys Med Biol* 17(3):365-373.
- Bors J, Martens R, Kuhn W. 1984. [Effect of microorganisms on the adsorption and translocation of radioiodine in soil.] *Atomkernenerg Kerntech* 44(1):87-88. (German)
- Borys RD, Duce RA. 1979. Relationships among lead, iodine, trace metals and ice nuclei in a coastal urban atmosphere. *J Appl Meteorol* 18(11):1490-1494.
- *Boulos MS, Becker VJ, Manuel OK. 1973. Iodine-129 in thyroid glands. *Health Phys* 24:375-378.
- Bourdoux P, Ermans A, Mukalay A, et al. 1995. Recommendations concerning iodine prophylaxis. *Eur J Endocrinol* 133:764.

9. REFERENCES

- *Bourdoux PP, Ermans AM, Mukalay A, et al. 1996. Iodine-induced thyrotoxicosis in Kivu, Zaire. *Lancet* 347:552-553.
- Bourke JR, Murdoch S, Manley SW, et al. 1991. Epidermal growth factor (EGF) inhibits the secretomotor response of the thyroid: effects of EGF on radioiodine turnover and fluid transport in cultured porcine thyroid cells. *J Endocrinol* 128:213-218.
- Bourrinet P, Dencausse A, Cochet P, et al. 1997. Secretion in milk and transplacental transfer of two iodized oils, Lipiodol UF and Oriodol, in rabbits. *Biol Neonate* 71:395-402.
- Bouville A. 1977. [Estimation of the doses of iodine-129 effluents from nuclear installations-local and regional scales.] In: *Iodine-129: Proceedings of an NEA specialist meeting*. Paris, France: Organisation for Economic Co-Operation and Development, 53-68. (French)
- Bouville A, Dreicer M, Beck HL, et al. 1990. Models of radioiodine transport to populations within the continental U.S. *Health Phys* 59(5):659-668.
- Bowlt C, Howe JR. 1992a. Measured human thyroid ¹²⁵I activities deriving from waste discharges in the Thames Valley area, UK. *J Radiol Prot* 12(2):59-65.
- Bowlt C, Howe JR. 1992b. The self-defining critical group and its application to a measured check of the derived limit for ¹²⁵I in drinking water. *Health Phys* 63(6):686-691.
- Bowlt C, Tiplady P. 1989. Radioiodine in human thyroid glands and incidence of thyroid cancer in Cumbria. *Br Med J* 299:301-302.
- Bowman JC. 1975. Iodide mumps. *J Tenn Dent Assoc* 55(4):212-213.
- Bowman KO, Shenton LR, Bernard SR. 1985. Study of age dependent half-life of iodine in man: A reinforcement-depletion urn model. *Bull Math Biol* 47(2):205-213.
- *Boyages SC. 2000a. The neuromuscular system and brain in hypothyroidism. In: Braverman LE, Utiger RD, eds. *Werner and Ingbar's the thyroid: A fundamental and clinical text*. 8th ed. Philadelphia, PA: Lippincott-Raven, 803-810.
- *Boyages SC. 2000b. The neuromuscular system and brain in thyrotoxicosis. In: Braverman LE, Utiger RD, eds. *Werner and Ingbar's the thyroid: A fundamental and clinical text*. 8th ed. Philadelphia, PA: Lippincott-Raven, 631-633.
- *Boyages SC, Bloot AM, Maberly GF, et al. 1989. Thyroid autoimmunity in endemic goitre caused by excessive iodine intake. *Clin Endocrinol* 31:452-465.
- *Boyd E, Ferguson-Smith MA, McDougall IR, et al. 1974. Chromosome breakage in human peripheral lymphocytes after radioactive iodine (¹²⁵I) treatment. *Radiat Res* 57:482-487.
- Brabant G, Bergmann P, Kirsch CM, et al. 1992. Early adaptation of thyrotropin and thyroglobulin secretion to experimentally decreased iodine supply in man. *Metabolism* 41:1093-1096.
- Branemark PI, Albrektsson B, Lindstrom J, et al. 1966. Local tissue effects of wound disinfectants. *Acta Chir Scand Suppl* 357:166-176.
- *Bratter P, Negretti de Bratter VEN. 1996. Influence of high dietary selenium intake on the thyroid hormone level in human serum. *J Trace Elements Med Biol* 10:163-166.
- Braverman LE. 1990. Effects of iodine on thyroid function in man. *Trans Am Clin Climatol Assoc* 102:143-151.

9. REFERENCES

- Braverman LE. 1994a. Deiodination of thyroid hormones: A 30 year perspective. *Exp Clin Endocrinol* 102:355-363.
- Braverman LE. 1994b. Iodine and the thyroid: 33 years of study. *Thyroid* 4(3):351-356.
- *Braverman LE, Roti E. 1996. Effects of iodine on thyroid function. *Acta Med Austriaca* 23:4-9.
- Braverman LE, Utiger RD. 1996a. Introduction to hypothyroidism. In: Braverman LE, Utiger RD, eds. *Werner and Ingbar's the thyroid: A fundamental and clinical text*. Philadelphia, PA: Lippincott-Raven, 736-737.
- Braverman LE, Utiger RD. 1996b. Introduction to thyrotoxicosis. In: Braverman LE, Utiger RD, eds. *Werner and Ingbar's the thyroid: A fundamental and clinical text*. Philadelphia, PA: Lippincott-Raven, 522-524.
- *Braverman LE, Utiger RD, eds. 2000. *Werner and Ingbar's: The thyroid: A fundamental and clinical text*. 8th ed. New York, NY: Lippincott Williams and Wilkins.
- *Braverman LE, Ingbar SH, Sterling K. 1970. Conversion of thyroxine (T₄) to triiodothyronine (T₃) in athyreotic human subjects. *J Clin Invest* 49:855-864.
- *Braverman LE, Ingbar SH, Vagenakis AG, et al. 1971a. Enhanced susceptibility to iodide myxedema in patients with Hashimoto's disease. *J Clin Endocrinol* 32:515-521.
- Braverman LE, Paul T, Reinhardt W, et al. 1987. Effect of iodine intake and methimazole on lymphocytic thyroiditis in the BB/W rat. *Acta Endocrinol* 281:70-76.
- Braverman LE, Vagenakis AG, Wang C-A, et al. 1971b. Studies on the pathogenesis of iodide myxedema. *Trans Assoc Am Physicians* 84:130-138.
- Braverman LE, Woeber KA, Ingbar SH. 1969. Induction of myxedema by iodide in patients euthyroid after radioiodine or surgical treatment of diffuse toxic goiter. *N Engl J Med* 281(15):816-821.
- Bremner VF, Kennedy JS. 1978. Radiation effects of iodine-125 and iodine-131 on the overactive rat thyroid. *Strahlentherapie* 154:413-418.
- *Brent GA, Larsen PR. 2000. Treatment of hypothyroidism. In: Braverman LE, Utiger RD, eds. *Werner and Ingbar's the thyroid: A fundamental and clinical text*. 8th ed. Philadelphia, PA: Lippincott-Raven, 851-858.
- Briancon C, Halpern S, Jeusset J, et al. 1992. Acute effects of various doses of iodide on thyroid iodine autoregulation. *Biol Trace Elem Res* 32:267-273.
- Briancon C, Halpern S, Telenczak P, et al. 1990. Changes in ¹²⁷I mice thyroid follicle studied by analytical ion microscopy: A key of the comprehension of amiodarone-induced thyroid diseases. *Endocrinology* 127(1):1502-1509.
- *Bricker NS, Hlad CJ. 1955. Observations on the mechanism of the renal clearance of I¹³¹. *J Clin Invest* 34:1057-1072.
- Brincker H, Hansen HS, Andersen AP. 1973. Induction of leukemia by ¹³¹I treatment of thyroid carcinoma. *Br J Cancer* 28:232.
- Brown AS, Susser ES, Butler PD, et al. 1996. Neurobiological plausibility of prenatal nutritional deprivation as a risk factor for schizophrenia. *J Nerv Ment Dis* 184(2):71-85.

9. REFERENCES

- Brown J. 1956. Extra-thyroidal iodide metabolism in the rat. *Endocrinology* 58:68-78.
- *Brown RS, Bloomfield S, Bednarek FJ, et al. 1997. Routine skin cleansing with povidone-iodine is not a common cause of transient neonatal hypothyroidism in North America: A prospective controlled study. *Thyroid* 7(3):395-400.
- *Brown TR, Bagchi N. 1992. The role of iodine in the development of autoimmune thyroiditis. *Int Rev Immunol* 9:167-182.
- *Brown-Grant K. 1961. Extrathyroidal iodide concentrating mechanisms. *Physiol Rev* 41:189-213.
- Brown-Grant K. 1967. A quantitative study of the effects of progesterone and related steroids on the uterus: Plasma concentration ratio for radioactive iodide in the rat. *J Endocrinol* 38:145-161.
- Brown-Grant K, Sherwood MR. 1971. Viability of the rat blastocyst following the oral administration of potassium perchlorate or potassium iodide to the mother. *J Reprod Fertil* 27:265-267.
- Brown-Grant K, John PN, Rogers AW. 1972. Analysis of the effects of progesterone on the synthesis of RNA and protein in the uterus of the ovariectomized rat and on the development of an iodide concentrating mechanism. *J Endocrinol* 53:363-374.
- *Bruhn JC, Franke AA, Bushnell RB, et al. 1983. Sources and content of iodine in California milk and dairy products. *J Food Prot* 46(1):41-46.
- *Bryant WP, Zimmerman D. 1995. Iodine-induced hyperthyroidism in a newborn. *Pediatrics* 95(3):434-436.
- Brzezinski J, Lewinski A, Karbownik M, et al. 1997. Effects of insulin-like growth factor I, epidermal growth factor and kalium iodide on thymidine kinase activity in homogenates of rat thyroid lobes incubated *in vitro*. *Biomed Lett* 55:153-167.
- Bubenhof R, Hedinger C. 1977. Schilddrüsenmalignome vor und nach einföhrung der jodsalzprophylaxe. *Schweiz Med Wochenschr* 107:733-741.
- Bucher H, Torresani T, Sobradillo B, et al. 1983. [Does PVP-iodine disinfection of newborn infants cause transient hypothyroidism? Report on 6 cases and prospective study of 19 early operated infants using T4 and TSH determinations of dried blood samples.] *Schweiz Med Wochenschr* 113(18):671-679. (German)
- Buczek A. 1993. Influence of iodine compounds on embryogenesis of *argas (A.) reflexus* (Fabricius, 1794) (Acari, Ixodida, Argasidae). *Acta Parasitol* 38(1):41-43.
- *Budavari S, O'Neil MJ, Smith A, et al., eds. 1998. *The Merck index: An encyclopedia of chemicals, drugs, and biologicals*. Whitehouse Station, NJ: Merck and Co., Inc.
- Budyka AK, Ogorodnikov BI. 1993a. [Calculation of gaseous fallout of Chernobyl accident by calculation of inhaled radiation dose.] *Radiats Biol Radioecol* 33(5):611-619. (Russian)
- Budyka AK, Ogorodnikov BI. 1993b. [Gaseous forms and aerosol particle sizes of iodine-131 products of Chernobyl accident during determination of inhaled dose radiaton.] *Radiats Biol Radioecol* 33(2):611-619. (Russian)
- Bundi RS, Scott JS, Halnan KE. 1977. Chronic myeloid leukemia following radioiodine therapy for carcinoma thyroid. *Br J Radiol* 50:61-64.

9. REFERENCES

- Bunzl K, Schimmack W. 1989. Associations between the fluctuations of the distribution coefficients of Cs, Zn, Sr, Co, Cd, Ce, Ru, Tc and I in the upper two horizons of a podzol forest soil. *Chemosphere* 18(11/12):2109-2120.
- Burakov VS, Isaevich AV, Misakov PY, et al. 1993. Intracavity laser spectroscopic method for determining trace amounts of iodine and barium in water and biological samples. *J Anal Atom Spectrom* 0:307-309.
- Burch HB, Gorman CA, Bahn RS, et al. 1996. Ophthalmopathy. In: Braverman LE, Utiger RD, eds. *Werner and Ingbar's the thyroid: A fundamental and clinical text*. Philadelphia, PA: Lippincott-Raven, 536-553.
- *Burch WM, Posillico JT. 1983. Hypoparathyroidism after I-131 therapy with subsequent return of parathyroid function. *J Clin Endocrinol Metab* 57(2):398-401.
- Burek CL, Talor M, Santana C, et al. 1998. Thyroiditis in NOD-H2^{h4} mice born and reared in conventional housing and ingesting different dose of iodine. *FASEB J* 12(5):A1097.
- Burger AG, Engler D, Buergi U, et al. 1983. Ether link cleavage is the major pathway of iodothyronine metabolism in the phagocytosing human leukocyte and also occurs in vivo in the rat. *J Clin Invest* 71:935-949.
- Burgi H, Andersen MC, Schwander J, et al. 1973. Secretion of thyroxine and non-thyroxine iodine by the normal human thyroid gland. Influence of carbimazole and pharmacological doses of iodide. *Eur J Clin Invest* 3:142-150.
- Burgi H, Baumbartner H, Steiger G. 1982. [Is there an upper limit of tolerance for dietary iodine administration?] *Schweiz Med Wochenschr* 112:2-7. (German)
- *Burgi H, Kohler M, Morselli B. 1998. Thyrotoxicosis incidence in Switzerland and benefit of improved iodine supply. *Lancet* 352:1034.
- Burgi H, Radvila A, Kohler H, et al. 1974. Effects of pharmacological doses of iodide on the hyperplastic rat thyroid gland. Roles of intrathyroid iodide, thyrotropin and thyroglobulin in the Wolff-Chaikoff phenomenon. *Endocrinology* 95:388-396.
- Burke G, Kowalski K. 1971. Comparative effects of thyrotropin and long-acting thyroid stimulator on iodide trapping isolated thyroid cells. *Acta Endocrinol* 68:645-656.
- Burke G, Silverstein GE. 1969. Hypothyroidism after treatment with sodium iodide I 131. *JAMA* 210(6):1051-1058.
- Burki HJ, Koch C, Wolff S. 1977. Molecular suicide studies of ¹²⁵I and ³H disintegration in the DNA of Chinese hamster cells. *Curr Top Radiat Res Q* 12:408-425.
- Burman KD, Smallridge RC, Burge JR, et al. 1987. Iodide administration enhances thyrotropin responsiveness to thyrotrophin-releasing hormone during fasting: Evidence for normal pituitary feedback regulation. *Clin Endocrinol* 26:9-15.
- Burmeister LA, Beatty RL, Wall JR. 1999. Malignant ophthalmopathy presenting one week after radioiodine treatment of hyperthyroidism. *Thyroid* 9(2):189-192.
- Burmeister LA, de Cret RP, Mariash CN. 1991. Local reactions to radioiodine in the treatment of thyroid cancer. *Am J Med* 90:217-222.
- Burnett JW. 1989. Iodides and bromides. *Cutis* 43(2):130.

9. REFERENCES

- Burns PA, Pegg JR. 1979. Thyroid measurements of iodine-125 workers. Australian Radiation Laboratory, Yallambie, Victoria, Australia. NTIS ARLTR008.
- Burrow GN. 1965. Neonatal goiter after maternal propylthiouracil therapy. *J Clin Endocrinol Metab* 25:403-408.
- *Burte PP, Nair AGC, Manohar SB, et al. 1991. Iodide and iodine uptake in plants. *J Radioanal Nucl Chem* 155(6):391-402.
- Bushnell DL, Boles MA, Kaufman GE, et al. 1992. Complications, sequela and dosimetry of iodine-131 therapy for thyroid carcinoma. *J Nucl Med* 33(12):2214-2221.
- *Bustad LK. 1964. *Biology of radioiodine*. Oxford, England: Pergamon Press.
- Buthieu A-M, Autissier N. 1977. [The effect of Mn²⁺ on thyroid iodine metabolism in rats.] *C R Seances Soc Biol Fil* 171(5):1024-1028. (French)
- *Butler EC, Gershey RM. 1984. Application of ion-exchange chromatography with an ion-selective electrode detector to iodine determination in natural waters. *Anal Chim Acta* 164:154-161.
- Buxeraud J, Absil AC, Raby C. 1984. Secondary antithyroid action of drugs in relation to structure. *J Pharm Sci* 73(12):1687-1690.
- Buxeraud J, Lagorce JF, Comby F, et al. 1992. Interaction between tetrahydro-3,5 dimethyl-2H-1,3,5 thiazidine-2-thione (MDTT or DAZOMET) and molecular iodine: Possible role in thyroid toxicity. *Int J Environ Stud* 42:177-186.
- Cabanillas AM, Masini-Repiso AM, Coleoni AH. 1991. Rat thyroid monoamine oxidase (MAO) is regulated by thyrotropin: evidence that the main form of the enzyme (MAO-A) is not directly involved in iodide organification. *J Endocrinol* 131:25-31.
- Cailleux A-F, Schlumberger MJ. 1998. The role of iodine-131 scanning and serum thyroglobulin in follow-up of differentiated thyroid carcinoma after total ablation. *Curr Opin Endocrinol Diabetes* 5:307-313.
- *Cann SA, van Netten JP, van Netten C. 2000. Hypothesis: Iodine, selenium and the development of breast cancer. *Cancer Causes Control* 11:121-127.
- Canning JF, Stacey TE, Ward RHT, et al. 1986. Radioiodide transfer across sheep placenta. *Am J Physiol* 250(19):R112-R119.
- Cantin M. 1967a. Skeletal muscle lesions in iodide-treated rats. *Arch Pathol* 83:500-506.
- Cantin M. 1967b. Study of a generalized erythema induced by iodide. *J Invest Dermatol* 48(6):560-566.
- Cao X-Y, Jiang X-M, Dou Z-H, et al. 1994. Timing of vulnerability of the brain to iodine deficiency in endemic cretinism. *N Engl J Med* 331:1739-1744.
- *Capar SG, Cunningham WC. 2000. Element and radionuclide concentrations in food: FDA total diet study 1991-1996. *J AOAC Int* 83(1):157-177.
- Caplan RH, Kujak R. 1971. Thyroid uptake of radioactive iodine. *JAMA* 215(6):916-918.
- *Caplan RH, Kujak R, Murvich S, et al. 1976. Current status of the radioactive ¹³¹I uptake test. *Minn. Med.* 59:530-535.

9. REFERENCES

- Carey JE, Swanson DP. 1979. Thyroid contamination from airborne I-131. *J Nucl Med* 20:362.
- *Carrasco N. 1993. Iodide transport in the thyroid gland. *Biochim Biophys Acta* 1154:65-82.
- Carroll KK. 1975. Experimental evidence of dietary factors and hormone-dependent cancers. *Cancer Res* 35:3374-3383.
- Carswell F, Kerr MM, Hutchinson JH. 1970. Congenital goitre and hypothyroidism produced by maternal ingestion of iodides. *Lancet* 1(7659):1241-1243.
- *Casara D, Rubello D, Saladini G, et al. 1993. Pregnancy after high therapeutic doses of iodine-131 in differentiated thyroid cancer: Potential risks and recommendations. *Eur J Nucl Med* 20:192-194.
- *Cassileth BR. 1999. Complementary and alternative cancer medicine. *J Clin Oncol* 17(11):44-52.
- Cassorla FG, Finegold DN, Parks JS, et al. 1983. Vasculitis, pulmonary cavitation, and anemia during antithyroid drug therapy. *Am J Dis Child* 137:118-122.
- Castaing H, Fournet JP, Leger FA, et al. 1979. [The thyroid gland of the newborn infant and postnatal iodine overload.] *Arch Fr Pediatr* 36(4):356-368. (French)
- Castronovo FP. 1986. Iodine-131 thyroid burdens of European travelers returning to Boston after the Chernobyl accident. *N Engl J Med* 315:1679-1680.
- Castronovo FP. 1987. Iodine-131 thyroid uptake results in travelers returning from Europe after the Chernobyl accident. *J Nucl Med* 28:535-541.
- *Catena C, Villani P, Nastasi R, et al. 1994. Micronuclei and 3AB-index in patients receiving iodine-131 therapy. *J Nucl Biol Med* 38:586-593.
- Caughey JE. 1970. Effects of iodation of bread. *Lancet* 1(7651):847.
- Cavalieri RR. 1996. Nuclear imaging in the management of thyroid carcinoma. *Thyroid* 6(5):485-492.
- *Cavalieri RR. 1997. Iodine metabolism and thyroid physiology: Current concepts. *Thyroid* 7(2):177-181.
- CDC. 1993. Hanford thyroid disease study: Study protocol. Atlanta, GA: Centers for Disease Control. Prepared under CDC Contract Number 200-89-0716, 1-13, 68.
- CDC. 1994. Radionuclide releases to the atmosphere from Hanford Operations, 1944-1972: Hanford environmental dose reconstruction project. Centers for Disease Control. PNWD-2222 HEDR UC-000. NTIS DE94 013 713.
- *CDC. 1999. Hanford thyroid disease study. Centers for Disease Control, Atlanta, GA. <http://www.fhrc.org/science/phs/htds/>.
- Cebulska-Wasilewska A. 1989. Comparison of ambient air mutagenicity detected with tradescantia stamen hairs after Chernobyl accident and one year later. *Environ Mol Mutagen* 14(Suppl 15):35.
- Celani VJ, Gee W, Kaupp HA, et al. 1989. Unusual symmetric common carotid lesions and oral iodine 131 for hyperthyroidism. *Vascular Surgery* 9(6):833-834.
- *Cember H. 1996. In: *Introduction to Health Physics*. 3rd ed. New York, NY: McGraw-Hill, 66.

9. REFERENCES

- *Centanni M, Robbins J. 1987. Role of sodium in thyroid hormone uptake by rat skeletal muscle. *J Clin Invest* 80:1068-1972.
- Cevallos JL, Hagen GA, Maloof F, et al. 1974. Low-dosage ¹³¹I therapy of thyrotoxicosis (diffuse goiters). *N Engl J Med* 290:141-143.
- *Chabrolle JP, Rossier A. 1978a. Danger of iodine skin absorption in the neonate [Letter]. *J Pediatr* 93(1):158-159.
- *Chabrolle JP, Rossier A. 1978b. Goitre and hypothyroidism in the newborn after cutaneous absorption of iodine. *Arch Dis Child* 53:495-498.
- *Chadha RK, Lawrence JF. 1990. Determination of iodide in dairy products and table salt by ion chromatography with electrochemical detection. *J Chromatogr* 518:268-272.
- *Chambard M, Verrier B, Gabrion J, et al. 1983. Polarization of thyroid cells in culture: Evidence for the basolateral localization of the iodide "pump" and of the thyroid-stimulating hormone receptor-adenyl cyclase complex. *J Cell Biol* 96:1172-1177.
- *Chameides WL, Davis DD. 1980. Iodine, its possible role in tropospheric photochemistry. *Journal of Geophysical Research* 85:7383-7398.
- Chan PC, Lisco E, Lisco H, et al. 1976. Radiotoxicity of intracellular ³H, ¹²²⁵I and ¹³¹I: A comparative study on cell survival and cytogenetic responses. *Radiat Res* 67:633.
- Chan PC, Lisco E, Lisco H, et al. 1977. Cell survival and cytogenetic responses to ¹²⁵I-UdR in cultured mammalian cells. *Curr Top Radiat Res Q* 12:426-435.
- Chan T, Scheier NW, O'Connor PA. 1997. A numerical study of the effects of a discrete fracture and an excavation damage zone on ¹²⁹I transport through the geosphere. *At Energy Can Ltd, [Rep] AECL* 11587:1-53.
- Chang J-K, Chen Y-C, Liu C-H, et al. 1984. A case of chronic myelogenous leukemia following ¹³¹I therapy for metastatic thyroid carcinoma. *J Formosan Med Assoc* 83:730-735.
- Chang T-C, Chang C-C, Chen F-W, et al. 1986. Long-term effect of radioiodine therapy on the thyroid antibodies in the patients of Graves' disease with postirradiation hypothyroidism. *J Formosan Med Assoc* 85:1177-1182.
- Chang Y-O. 1969. Effect of iodinated casein on production of vitamin B₁₂ and folic acid deficiency in rats. *Am J Physiol* 216(1):11-15.
- Chang-Chien Y, Liaw K-Y, Wang D-J, et al. 1977. Thyroid cancer after irradiation. *Int Surg* 62(2):112-114.
- Chanoine JP, Toppet V, Bourdoux P, et al. 1991. Smoking during pregnancy: A significant cause of neonatal thyroid enlargement. *Br J Obstet Gynaecol* 98:65-68.
- Chapman EM, Corner GW, Robinson D, et al. 1948. The collection of radioactive iodine by the human fetal thyroid. *J Clin Endocrinol Metab* 8:717-720.
- Chapman RS, Main RA. 1967. Diffuse thinning of hair in iodide-induced hypothyroidism. *Br J Dermatol* 79(2):103-105.

9. REFERENCES

- Chapman WH. 1968. The changing frequency of thyroid carcinoma and Hashimoto's thyroiditis as related to diagnostic criteria, iodized salt, and radiation. Lawrence Radiation Laboratory, University of California at Livermore, Bio-Medical Division. California. TID-4500, UC-48.
- Chas J, Marciniak M, Baltrukiewicz Z. 1990. Retention of iodine upon intravenous or oral administration of Na¹³¹I and the absorbed doses of radiation derived from iodine radioisotopes incorporated into mature rats and sucklings. *Nucleonika* 35(7-9):195-211.
- *Chazenbalk GD, Nagayama Y, Kaufman KD, et al. 1990. The functional expression of recombinant human thyrotropin receptors in nonthyroidal eukaryotic cells provides evidence that homologous desensitization to thyrotropin stimulation requires a cell-specific factor. *Endocrinology* 127(3):1240-1244.
- Chazenbalk GD, Valsecchi RM, Krawiec L, et al. 1988. Thyroid autoregulation, inhibitory effects of iodinated derivatives of arachidonic acid on iodine metabolism. *Prostaglandins* 36(2):163-172.
- Chegrinets G. 1992. [The iodine level of the environment and the risk of developing thyroid diseases.] *Lik Sprava* 4:16-19. (Russian)
- Chemfinder. 2001. Iodine. Chemfinder.com: Database and internet searching. <http://www.chemfinder.com>.
- Chen J-Y, Huang H-S, Huang M-J, et al. 1990. Outcome following radioactive iodine therapy in Graves' disease. *Chang Keng I Hsueh Tsa Chih* 13(4):258-267.
- Chen S-H, Wu S-M, Kou H-S, et al. 1994. Electron-capture gas chromatographic determination of cyanide, iodide, nitrite, sulfide, and thiocyanate anions by phase-transfer-catalyzed derivatization with pentafluorobenzyl bromide. *J Anal Toxicol* 18:81-85.
- *Chernyshov VP, Vykhoanets EV, Slukvin II, et al. 1998. Effect of iodine isotope on the pituitary-thyroid and immune systems of children living on the territories polluted by radionuclides. *Bull Exp Biol Med* 126(8):835-838.
- *Cherstvoy ED, Nerovnya AM, Pozharskaya VP, et al. 1996. Thyroid carcinomas in children of the Republic of Belarus. In: Nagataki S, Yamashita S, eds. *Nagasaki symposium radiation and human health: Proposal from Nagasaki*. Amsterdam, the Netherlands: Elsevier, 43-48.
- Chester HA, Pisarev MA, Juvenal GJ, et al. 1990. Further studies on iodide uptake autoregulation in calf thyroid slices. *Acta Physiol Pharmacol Latinoam* 40:149-154.
- Chiacchierini RP. 1990. Iodine-131 exposures and neoplasia. *Radiat Res* 124(3):359-360.
- Ching M. 1981. Dose-related effect of growth hormone on thyroidal radioiodine uptake. *Horm Res* 14:234-242.
- Chiovato L, Fiore E, Vitti P, et al. 1998. Outcome of thyroid function in Graves' patients treated with radioiodine: Role of thyroid-stimulating and thyrotropin-blocking antibodies and of radioiodine-induced thyroid damage. *J Clin Endocrinol Metab* 83(1):40-46.
- Chiovato L, Santini F, Vitti P, et al. 1994. Appearance of thyroid stimulating antibody and Graves' disease after radioiodine therapy for toxic nodular goitre. *Clin Endocrinol* 40:803-806.
- Chisholm JC. 1981. Hypothyroidism: A rare cause of the bilateral carpal tunnel syndrome-a case report and a review of the literature. *J Natl Med Assoc* 73(11):1082-1085.

9. REFERENCES

- Chiu AC, Sherman SI. 1997. Clinical manifestations and differential diagnosis of hypothyroidism. In: Falk SA, ed. *Thyroid disease: Endocrinology, surgery, nuclear medicine, and radiotherapy*. Philadelphia, PA: Lippincott-Raven Publishers, 379-391.
- Choe SY, Yen-Chow YC, Woodbury DM. 1982. Effects of thyrotropin, acetazolamide, 4-acetamido-4'-isothiocyanostilbene-2,2'-disulfonic acid, perchlorate, and ouabain on the distribution of iodide ions in cells and luminal fluid of turtle thyroid. *Endocrinology* 110(1):121-125.
- Chopra IJ. 1996. Nature, source, and relative significance of circulating thyroid hormones. In: Braverman LE, Utiger RD, eds. *Werner and Ingbar's the thyroid: A fundamental and clinical text*. Philadelphia, PA: Lippincott-Raven, 111-124.
- *Chow CC, Phillips DIW, Lazarus JH, et al. 1991. Effect of low dose iodide supplementation on thyroid function in potentially susceptible subjects: Are dietary iodide levels in Britain acceptable? *Clin Endocrinol* 34:413-416.
- Chow SY, Kemp JW, Woodbury DM. 1983. Effects of acetazolamide on iodide transport, electrolyte distribution and activities of carbonic anhydrase, Na⁺, K⁺-ATPase and HCO₃⁻-ATPase in mouse, rat and turtle thyroid gland. *J Endocrinol* 97:167-174.
- Christensen VL, Ort JF. 1991. Iodine toxicity in large white turkey breeder hens. *Poult Sci* 70:2402-2410.
- Christov K. 1978. Radiation-induced thyroid tumors in infant rats. *Radiat Res* 73:330-339.
- Christov K, Raichev R. 1972. Thyroid carcinogenesis in hamsters after treatment with 131-iodine and methylthiouracil. *Z Krebsforsch* 77:171-179.
- Christov K, Raichev R. 1973. Proliferative and neoplastic changes in the ovaries of hamsters treated with 131-iodine and methylthiouracil. *Neoplasma* 20(5):511-516.
- *Chu SYF, Ekstrom LP, Firestone RB. 1999. Isotope explorer: WWW table of radioactive isotopes. <http://nucleardata.nuclear.lu.se/nucleardata/toi/listnuc.asp?>
- Clark DE. 1955. Association of irradiation with cancer of the thyroid in children and adolescents. *JAMA* 159(10):1007-1009.
- *Clark MN. 1981. A fatal case of iodine poisoning. *Clin Toxicol* 18(7):807-811.
- Clark WE, Thompson CT. 1977. Immobilization of iodine in concrete. (to The United States of America as represented by the United States Energy Research and Development Administration) Application: United States 4,017,417, 12 Apr 1977. United States Patent 4,017,417, issued 12 Apr 1977.
- Clayson DB. 1975. Nutrition and experimental carcinogenesis: A review. *Cancer Res* 35:3292-3300.
- Clayton CG. 1953. Irregularities of iodine assimilation by the follicles of the rat thyroid. *Br J Radiol* 26:99-101.
- Clemens PC, Neumann RSJ. 1989a. The Wolff-Chaikoff effect: Hypothyroidism due to iodine application [Letter]. *Arch Dermatol* 125(5):705.
- Clemens PC, Neumann S. 1989b. Transient primary hypothyroidism in the neonate. *Clin Pediatr* 28(7):335.
- *Clewell HJ III, Andersen ME. 1985. Risk assessment extrapolations and physiological modeling. *Toxicol Ind Health* 1(4):111-131.

9. REFERENCES

- Coakley FV, Panicek DM. 1997. Iodine allergy: An oyster without a pearl? *Am J Roentgenol* 169(4):951-952.
- Coakley FV, Panicek DM. 1998. Reply [Letter]. *Am J Roentgenol* 171(2):518-519.
- *Coakley JC, Francis I, Gold H, et al. 1989. Transient primary hypothyroidism in the newborn: Experience of the Victorian Neonatal Thyroid Screening Programme. *Aust Paediatr J* 25:25-30.
- Cobb LM, Harrison A, Dudley NE, et al. 1989. Relative concentration of astatine-211 and iodine-125 by human fetal thyroid and carcinoma of the thyroid in nude mice. *Radiother Oncol* 13:203-209.
- Codaccioni J-L, Valery-Milhaud F, Ochi C. 1987. [Carbimazole administered alone can be effective in the treatment of hyperthyroidism induced by iodine.] *Presse Med* 16(6):312. (French)
- Cody V. 1996. Thyroid hormone structure-function relationships. In: Braverman LE, Utiger RD, eds. *Werner and Ingbar's the thyroid: A fundamental and clinical text*. Philadelphia, PA: Lippincott-Raven, 185-189.
- *Cohen BI. 1985. The origin of I in soil and the ¹²⁹I problem. *Health Phys* 49(2):279-285.
- Cohen J, Gierlowski TC, Schneider AB. 1990. A prospective study of hyperparathyroidism in individuals exposed to radiation in childhood. *JAMA* 264(5):581-584.
- Cohen JC, Roxe DM, Said R, et al. 1980. Iodide mumps after repeated exposure to iodinated contrast media. *Lancet* 1:762-763.
- Cohen SB, Weetman AP. 1988. The effect of iodide depletion and supplementation in the Buffalo strain rat. *J Endocrinol Invest* 11:625-627.
- *Cohn BNE. 1932. Absorption of compound solution of iodine from the gastro-intestinal tract. *Arch Intern Med* 49:950-956.
- *Cohn SH, Gusmano EA. 1963. Uptake and transfer of fallout ¹³¹I in pregnant women. *Health Phys* 9:1267-1269.
- Colin IM, Selvais PL, Rebai T, et al. 1994. Expression of the endothelin-1 gene in the rat thyroid gland and changes in its peptide and mRNA levels in goiter formation and iodide-induced involution. *J Endocrinol* 143:65-74.
- Collins SL. 1997. Thyroid cancer: Controversies and etiopathogenesis. In: Falk SA, ed. *Thyroid disease: Endocrinology, surgery, nuclear medicine, and radiotherapy*. Philadelphia, PA: Lippincott-Raven Publishers, 495-564.
- Collins WT, Capen CC. 1980a. Biliary excretion of ¹²⁵I-thyroxine and fine structural alterations in the thyroid glands of Gunn rats fed polychlorinated biphenyls (PCB). *Lab Invest* 43:158-164.
- Collins WT, Capen CC. 1980b. Ultrastructural and functional alterations of the rat thyroid gland produced by polychlorinated biphenyls compared with iodide excess and deficiency, and thyrotropin and thyroxine administration. *Virchows Arch B* 33:213-231.
- *Comar CL, Wentworth RA, Georgi JR. 1963. Thyroidal deposition in man, rat and dog of radioiodine from milk and non-milk sources. *Health Phys* 9:1249-1252.
- *Conard RA. 1984. Late radiation effects in Marshall Islanders exposed to fallout 28 years ago. In: Boice KD, Fraumeni JF, eds. *Radiation carcinogenesis: Epidemiology and biological significance*. New York, NY: Raven Press, 57-71.

9. REFERENCES

- *Conard RA, Dobyns BM, Sutow WW. 1970. Thyroid neoplasia as late effect of exposure to radioactive iodine in fallout. *JAMA* 214(2):316-324.
- Connell JMC, Hilditch TE, McCrudden DC, et al. 1983. Transient hypothyroidism following radioiodine therapy for thyrotoxicosis. *Br J Radiol* 56:309-313.
- Connolly KJ, Pharoah POD, Hetzel BS. 1979. Fetal iodine deficiency and motor performance during childhood. *Lancet* 2:1149-1151.
- *Connolly RJ. 1971a. The changing iodine environment of Tasmania. *Med J Aust* 2:1191-1193.
- *Connolly RJ. 1971b. An increase in thyrotoxicosis in southern Tasmania after an increase in dietary iodine. *Med J Aust* 1(24):1268-1271.
- *Connolly RJ, Shepherd JJ. 1972. The effect of preoperative surgical scrubbing with providone iodine on urinary iodine levels. *Aust N Z J Surg* 42(1):94-95.
- *Connolly RJ, Vidor GI, Stewart JC. 1970. Increase in thyrotoxicosis in endemic goitre area after iodation of bread. *Lancet* 1(7645):500-502.
- Conrad LM, Hemken RW. 1978. Milk iodine as influenced by an iodophor teat dip. *J Dairy Sci* 61:776-780.
- *Contempré B, Duale NL, Dumont JE, et al. 1992. Effect of selenium supplementation on thyroid hormone metabolism in an iodine and selenium deficient population. *Clin Endocrinol* 36:579-583.
- *Contempré B, Dumont JE, Ngo B, et al. 1991. Effect of selenium supplementation in hypothyroid subjects of an iodine and selenium deficient area: The possible danger of indiscriminate supplementation of iodine-deficient subjects with selenium. *J Clin Endocrinol Metab* 73(1):213-215.
- Convey EM, Chapin L, Kesner JS, et al. 1979. Serum thyrotropin and thyroxine after thyrotropin releasing hormone in dairy cows fed varying amounts of iodine. *J Dairy Sci* 60(6):975-980.
- *Cooper DS. 2000. Treatment of thyrotoxicosis. In: Braverman LE, Utiger RD, eds. *Werner and Ingbar's the thyroid: A fundamental and clinical text*. 8th ed. Philadelphia, PA: Lippincott-Raven, 691-715.
- Cooper DS. 1998. Radioiodine for hyperthyroidism: Where do we stand after 50 years? *JAMA* 280(4):375-376.
- Cooper RM. 1988. Potassium iodide for radiation exposure. *Drug Intell Clin Pharm* 22:33-34.
- Coover LR. 1999. Vocal cord paralysis after ¹³¹I therapy for solitary toxic nodule. *J Nucl Med* 40:505.
- Coppa A, Mincione G, Mammarella S, et al. 1995. Epithelial rat thyroid cell clones, escaping from transforming growth factor beta negative growth control, are still inhibited by this factor in the ability to trap iodide. *Cell Growth Differ* 6:281-290.
- Coppola M, Vulpis N, Bertoncetto G. 1984. Enhancement of chromosomal damage in human lymphocytes irradiated with x rays in the presence of iodine. *Radiat Prot Dosim* 9(2):99-104.
- Corah LR, Ives S. 1991. The effect of essential trace minerals on reproduction in beef cattle. *Vet Clin North Am* 7(1):41-57.

9. REFERENCES

- Corda D, Kohn LD. 1986. Role of pertussis toxin sensitive G proteins in the α_1 adrenergic receptor but not in the thyrotropin receptor mediated activation of membrane phospholipases and iodide fluxes in FRTL-5 thyroid cells. *Biochem Biophys Res Commun* 141(3):1000-1006.
- Corda D, Marcocci C, Kohn LD, et al. 1985. Association of the changes in cytosolic Ca^{2+} and iodide efflux induced by thyrotropin and by the stimulation of α_1 -adrenergic receptors in cultured rat thyroid cells. *J Biol Chem* 260(16):9230-9236.
- *Cornelis R, Speecke A, Hoste J. 1975. Neutron activation analysis for bulk and trace elements in urine. *Anal Chim Acta* 78:317-327.
- *Corvilain B, Dumont JE, Vassart G. 2000. Toxic adenoma and toxic multinodular goiter. In: Braverman LE, Utiger RD, eds. *Werner and Ingbar's the thyroid: A fundamental and clinical text*. 8th ed. Philadelphia, PA: Lippincott-Raven, 564-572.
- Corvilain B, Laurent E, Lecomte M, et al. 1994. Role of the cyclic adenosine 3',5'-monophosphate and the phosphatidylinositol- Ca^{2+} cascades in mediating the effects of thyrotropin and iodide on hormone synthesis and secretion in human thyroid slices. *J Clin Endocrinol Metab* 79(1):152-159.
- Corvilain B, Van Sande J, Dumont JE. 1988. Inhibition of iodide by iodide binding to proteins: The "Wolff-Chaikoff" effect is caused by inhibition of H_2O_2 generation. *Biochem Biophys Res Commun* 154(3):1287-1292.
- *Corvilain B, Van Sande J, Dumont JE, et al. 1998. Autonomy in endemic goiter. *Thyroid* 8(1):107-113.
- Cosmetic Ingredient Review Expert Panel. 1995. Final report on the safety assessment of sodium iodate. *J Am Coll Toxicol* 14(3):231-239.
- Coughtrey PJ, Jackson D, Thorne MC. 1983. Iodine. In: *Radionuclide distribution and transport in terrestrial and aquatic ecosystems: A critical review of data*. Rotterdam: A.A. Balkema, 322-372.
- Cowin AJ, Bidey SP. 1995. Porcine thyroid follicular cells in monolayer culture activate the iodide-responsive precursor form of transforming growth factor-beta1. *J Endocrinol* 144:67-73.
- *Cox RA, Bloss WJ, Jones RL, et al. 1999. OIO and the atmospheric cycle of iodine. *Geophys Res Lett* 26(13):1857-1860.
- Cox RJ, Pickford CJ, Thompson M. 1992. Determination of iodine-129 in vegetable samples in inductively coupled plasma mass spectrometry. *J Anal Atom Spectrom* 7:635-640.
- Craswell PWT. 1972. Vocal cord paresis following radioactive iodine therapy. *Br J Clin Pract* 26(12):571-572.
- Creutzig H, Hundeshagen H. 1977. [Thyroid cancer risk from Iodine-131 treatment.] *Med Klin* 72(19):855-857. (German)
- Crile GJ, Esselstyn CBJ, Cook SA. 1979. Cancer of the thyroid appearing after (but probably not caused by) treatment with radioactive iodine. *Cleve Clin Q* 46(4):159-162.
- Crocker DG. 1984. Nuclear reactor accidents-the use of KI as a blocking agent against radioiodine uptake in the thyroid-a review. *Health Phys* 46(6):1265-1279.
- Croughs W, Visser HKA. 1965. Familial iodide-induced goiter. Evidence for an abnormality in the pituitary-thyroid homeostatic control. *J Pediatr* 67:353-362.

9. REFERENCES

- *Cuddihy RG. 1966. Thyroidal iodine-131 uptake, turnover and blocking in adults and adolescents. *Health Phys* 12:1021-1025.
- Culpepper RM, Hirsch JI, Fratkin MJ. 1992. Clearance of ¹³¹I by hemodialysis. *Clin Nephrol* 28(2):110-114.
- Cunnen AJ, Hay ID, Gorman CA, et al. 1982. Radioiodine-induced hypothyroidism in Graves' disease: Factors associated with the increasing incidence. *J Nucl Med* 23:978-983.
- *Cunningham WC, Anderson DL, Baratta EJ. 1994. Radionuclides in domestic and imported foods in the United States, 1987-1992. *J AOAC Int* 77(6):1422-1427.
- *Cunningham WC, Stroube WB, Baratta EJ. 1989. Radionuclides in domestic and imported foods in the United States, 1983-1986. *J Assoc Off Anal Chem* 72(1):15-18.
- *Curd JG, Milgrom H, Stevenson DD, et al. 1979. Potassium iodide sensitivity in four patients with hypocomplementemic vasculitis. *Ann Intern Med* 91:853-857.
- *Curran PG, DeGroot LJ. 1991. The effect of hepatic enzyme-inducing drugs on thyroid hormones and the thyroid gland. *Endocrine Rev* 12(2):135-150.
- Cvejic D, Savin S, Sinadinovic J. 1997. Effects of thyrotropin and insulin-like growth factor I (IGF-I) on ³H-thymidine incorporation and iodine metabolism in cultured porcine thyroid follicles. *Iugosl Physiol Pharmacol Acta* 33:33-43.
- *Dai G, Levy O, Carrasco N. 1996. Cloning and characterization of the thyroid iodide transporter. *Nature* 379:458-460.
- *Dalmark M. 1976. Effects of halides and bicarbonate on chloride transport in human red blood cells. *J Gen Physiol* 67:223-234.
- *Dams R, Robbins JA, Rahn KA, et al. 1970. Nondestructive neutron activation analysis of air particulates. *Anal Chem* 42:861-867.
- Daniels AL, Everson GJ. 1935. The relation of manganese to congenital debility. *J Nutr* 9(2):191-203.
- Das SC, Isichei UP. 1993. The "feto-maternal" thyroid function interrelationships in an iodine-deficient region in Africa-the role of T₃ in possible fetal defence. *Acta Endocrinol* 128:116-119.
- Datz FL. 1986. Cerebral edema following iodine-131 therapy for thyroid carcinoma metastatic to the brain. *J Nucl Med* 27:637-640.
- Daunt N. 1998. Iodine allergy. [Letter]. *Am J Roentgenol* 171(2):518. See also Coakley & Panicek, 1998.
- Davidovich D, Stigliano H, Garcis JRAR, et al. 1970. [Study of thyroid function in 20 inhabitants of a zone with an excess of iodine in the drinking water.] *Rev Argent Endocrinol Metab* 16(3):75-79. (Spanish)
- Davidson DC, Ford JA, Fox EG. 1974. Iodide sialadenitis in childhood. *Arch Dis Child* 49(1):67-68.
- Davies TF. 1996. Graves' disease: The pathogenesis of Graves' disease. In: Braverman LE, Utiger RD, eds. *Werner and Ingbar's the thyroid: A fundamental and clinical text*. Philadelphia, PA: Lippincott-Raven, 525-536.

9. REFERENCES

- Davies TF, Yang C, Platzer M. 1989. The influence of antithyroid drugs and iodine on thyroid cell MHC class II antigen expression. *Clin Endocrinol* 31:125-135.
- Davis RJ. 1980. To the editor. *Ann Intern Med* 92(5):712-713.
- Dawson CA, Skebba SC, Linehan JH, et al. 1985. Influence of pulmonary embolism on absorption of inhaled iodide-125. *J Appl Physiol* 58(4):1061-1068.
- Dawson KP. 1970. Congenital goitrous cretinism due to iodide. *Br Med J* 2(701):112-113.
- De SK, Ganguly CK, Chakraborty TK, et al. 1985. Endocrine control of extrathyroidal peroxidases and iodide metabolism. *Acta Endocrinol* 110:383-387.
- De Braekeleer M, Mayer G, Chaventre A. 1998. Genetic factors in iodine deficiency disorders: A general review. *Coll Antropol* 1:9-15.
- *DeCheke ME. 1989. Chemical analysis of water and wastewater. *Inorganics. Journal WCPF* 61(6):727-755.
- Degroot LJ. 1997. Radioiodine and the immune system. *Thyroid* 7(2):259-264.
- Degroot LJ, Reilly M. 1982. Comparison of 30- and 50-mCi doses of iodine-131 for thyroid ablation. *Ann Intern Med* 96:51-53.
- DeGroot LJ, Reilly M, Pinnameneni K, et al. 1983. Retrospective and prospective study of radiation-induced thyroid disease. *Am J Med* 74:852-862.
- *De Groot R. 1979. The hazards of iodine-125 labeling-a recommended code of practice. *Australas Phys Sci Med* 2(7):386-393.
- *Delange F. 1990. Iodine nutrition and risk of thyroid irradiation from nuclear accidents. In: Rubery E, Smales E, eds. *Iodine prophylaxis following nuclear accidents*. Oxford, UK: Pergamon Press, 45-54.
- Delange F. 1996. Administration of iodized oil during pregnancy: A summary of the published evidence. *Bull W H O* 74(1):101-108.
- Delange F. 1998a. Screening for congenital hypothyroidism used as an indicator of the degree of iodine deficiency and of its control. *Thyroid* 8(12):1185-1192.
- Delange F. 1998b. Search for effective immunomodulating strategies against sepsis. *Lancet* 351:922-923.
- *Delange FM, Ermans A-M. 1996. Iodine deficiency. In: Braverman LE, Utiger RD, eds. *Werner and Ingbar's the thyroid: A fundamental and clinical text*. Philadelphia, PA: Lippincott-Raven, 296-316.
- Delange F, Chanoine JP, Abrassari C, et al. 1988. Topical iodine, breastfeeding, and neonatal hypothyroidism [Letter]. *Arch Dis Child* 63(1):106-107.
- *Delange F, de Benoist B, Alnwick D. 1999. Risks of iodine-induced hyperthyroidism after correction of iodine deficiency by iodized salt. *Thyroid* 9(6):545-556.
- Delange F, Van Minh N, Vanderlinden L, et al. 1980. Influence of goitrogens in pregnant and lactating rats on thyroid function in the pups. In: Ermans AM, Mbulamoko NM, Delange F, et al., eds. *Role of cassava in the etiology of endemic goitre and cretinism*, 167-182.
- *Dellavalle ME, Barbano DM. 1984. Iodine content of milk and other foods. *J Food Prot* 47:678-684.

9. REFERENCES

- DeLong GR. 1996. 'Iodine and brain development' [Letter]. *Dev Med Child Neurol* 38:278-282.
- *De Luca Rebello A, Herms FW, Wagener K. 1990. The cycling of iodine as iodate and iodide in a tropical estuarine system. *Marine Chemistry* 29:77-93.
- Demangeat K-L, Lautier F, Demangeat C, et al. 1982. [Consequences of the chronic cutaneous application of iodinated antiseptics on the thyroid function in the guinea-pig.] *Zentralbl Bakteriol [B]* 176:277-290. (German)
- *Deme D, Doussuere J, de Sandro V et al. 1994. The Ca²⁺/NADPH-dependent H₂O₂ generator in thyroid plasma membrane: Inhibition by diphenyleneiodium.
- Demir M, Kabasakal L, Onsel C. 1996. Evaluation of external radiation exposure rate from radioiodine-treated hyperthyroid patients and radiation safety considerations. *Nucl Med Commun* 17:692-695.
- Denef J-F, Many M-C, van den Hove MF. 1996. Iodine-induced thyroid inhibition and cell necrosis: Two consequences of the same free-radical mediated mechanism? *Mol Cell Endocrinol* 121:101-103.
- Denham MJ, Himsworth RL. 1974. Hyperthyroidism induced by potassium iodide given in the course of ¹²⁵I-fibrinogen test. *Age Ageing* 3:221-225.
- De Prosio N, De Martino LJ, McGuinness ET. 1968. Melatonin's effect on ¹³¹I uptake by the thyroid glands in normal and ovariectomized rats. *Life Sci* 7:183-188.
- Derwahl M, Manole D, Sobke A, et al. 1998. Pathogenesis of toxic thyroid adenomas and nodules: Relevance of activating mutations in the TSH-receptor and Gs-alpha gene, the possible role of iodine deficiency and secondary and TSH-independent molecular mechanisms. *Exp Clin Endocrinol Diabetes* 106(Suppl 4):S6-S9.
- De Sandro V, Catinot R, Kriszt W, et al. 1992. Male rat hepatic UDP-glucuronosyltransferase activity toward thyroxine: Activation and induction properties-relation with thyroxine plasma disappearance rate. *Biochem Pharmacol* 43(7):1563-1569.
- De Vathaire F, Fragu P, Francois P, et al. 1993. Long-term effects on the thyroid of irradiation for skin angiosarcomas in childhood. *Radiat Res* 133:381-386.
- de Vathaire F, Schlumberger M, Delisle MJ, et al. 1997. Leukemia and cancers following iodine-131 administration for thyroid cancer. *Br J Cancer* 75(5):734-739.
- Deves JR, Tonkin JP. 1980. Vocal cord paralysis in benign thyroid disease before operation. *Med J Aust* 2(11):632.
- de Vijlder JJM, Vulsma T. 1996. Hereditary metabolic disorders causing hypothyroidism. In: Braverman LE, Utiger RD, eds. *Werner and Ingbar's the thyroid: A fundamental and clinical text*. Philadelphia, PA: Lippincott-Raven, 749-755.
- DeWitte M, Eberhart RJ, Griel LCJ. 1980. Mastitis caused by teat-dipping error. *Vet Med Small Anim Clin* 75(10):1613-1616.
- *de Zegher F, Vanhole C, Van den Berghe G, et al. 1994. Properties of thyroid-stimulating hormone and cortisol secretion by the human newborn on the day of birth. *J Clin Endocrinol Metab* 79:576-581.
- Diamond ML, Mackay D, Cornett RJ, et al. 1990. A model of the exchange of inorganic chemicals between water and sediments. *Environ Sci Technol* 24:713-722.
- Dienhart KJ. 1974. Suppurative ulcerating iododerma [Letter]. *N Engl J Med* 290(9):521.

9. REFERENCES

- *Dietrich AM, Costa WFD. 1997. Measurement and monitoring of pollutants. Chemical species. *Water Environ Res* 69(4):391-403.
- Di Girolamo M, D'Arcangelo D, Bizzarri C, et al. 1991. Muscarinic regulation of phospholipase A₂ and iodide fluxes in FRTL-5 thyroid cells. *Acta Endocrinol* 125:192-200.
- Di Lauro E. 1966. [Ludwig's pseudoangina due to iodism.] *Ann Laringol Otol Rinol Faringol* 65(2):261-263. (Italian)
- Dixon GW. 1996. Processed product for skin and hair treatment. Application: USA 5,554,361, 10 Sep 1996. USA Patent 5,554,361, issued 10 Sep 1996.
- Dluhy RG. 1996a. The adrenal cortex in hypothyroidism. In: Braverman LE, Utiger RD, eds. *Werner and Ingbar's the thyroid: A fundamental and clinical text*. Philadelphia, PA: Lippincott-Raven, 841-844.
- Dluhy RG. 1996b. The adrenal cortex in thyrotoxicosis. In: Braverman LE, Utiger RD, eds. *Werner and Ingbar's the thyroid: A fundamental and clinical text*. Philadelphia, PA: Lippincott-Raven, 656-660.
- Dmitrev AI, Istomina GN. 1978. [Long term changes in the endurance of rats after combined external gamma irradiation and contamination with radioactive iodine.] *Radiobiologiya* 18(5):777-779. (Russian)
- DNA. 1992. Evaluation of residual radioactivity in human tissues associated with weapons testing at the Nevada test site. Alexandria, VA: Defense Nuclear Agency. DNA-TR-91-166.
- Dobyns BM. 1975. Radiation effects of radioiodine on the thyroid: Effects vary with dosage and sensitivity of the gland to radiation. *R I Med J* 58(3):94-97.
- Dobyns BM, Sheline GE, Workman JB, et al. 1974. Malignant and benign neoplasms of the thyroid in patients treated for hyperthyroidism: A report of the cooperative thyrotoxicosis therapy follow-up study. *J Clin Endocrinol* 38:976-998.
- *Docter R, Krenning EP, Bernard HF, et al. 1987. Active transport of iodothyronines into human cultured fibroblasts. *J Clin Endocrinol Metab* 65(4):624-628.
- *DOE. 1954. Thyroid absorbed dose for people at Rongelap, Utirik, and Sifo on March 1, 1954. U.S. Department of Energy. BNL 51882.
- *DOE. 1978a. Iodine-129: A review of its potential impact on the environment. U.S. Department of Energy. NTIS Y/OWI/Sub-7278/1.
- *DOE. 1978b. Methodology for the determination of environmental exp 129 U and exp 99 TC. U.S. Department of Energy. NTIS DPMS7775.
- DOE. 1980. Measurements of deposition and biological half-life of iodine on vegetation. Washington, DC: U.S. Department of Energy. NTIS DE83000759.
- DOE. 1985. Volatilization of iodine from soils and plants. Washington, DC: U.S. Department of Energy. NTIS DE85018226.
- *DOE. 1986. U.S. Department of Energy. A literature review of the concentration ratios of selected radionuclides in freshwater and marine fish. NTIS DE86 015820. 1021, 82-87, 243-272.
- *DOE. 1990. U.S. Department of Energy. Savannah River site radionuclide atmospheric releases and offsite maximum doses. NTIS DE93 004259.

9. REFERENCES

- DOE. 1992a. Analysis of iodine-129 in aqueous samples by inductively coupled plasma-mass spectrometry. Washington, DC: U.S. Department of Energy. NTIS DE93002694.
- DOE. 1992b. Chemical contaminants on DOE lands and selection of contaminant mixtures for subsurface science research. Washington, DC: U.S. Department of Energy. NTIS DE92-014826.
- DOE. 1992c. External radiation doses in a household from a patient receiving a therapeutic amount of ¹³¹I. New York, NY: U.S. Department of Energy, Environmental Measurements Laboratory. EML-547.
- DOE. 1992d. National low-level waste management program radionuclide report series: Volume 4: Iodine-129. Idaho: U.S. Department of Energy, Office of Environmental Restoration and Waste Management, Idaho Field Office. NTIS DE93 007049.
- *DOE. 1993. U.S. Department of Energy. Air pathway effects of nuclear materials production at the Hanford site, 1983 to 1992. NTIS DE94002708.
- *DOE. 1994. U.S. Department of Energy. Iodine-129 in the Snake River plain aquifer at and near the Idaho National Engineering Laboratory, Idaho, 1990-91. NTIS DE95001913.
- DOE. 1995. U.S. Department of Energy. Technetium-99, iodine-129 and tritium in the waters of the Savannah River site. NTIS DE95004803.
- *DOE. 1996a. Closing the circle on the splitting of the atom: The environmental legacy of nuclear weapons production in the United States and what the department of energy is doing about it. Washington, DC: Office of Environmental Management, U.S. Department of Energy. DOE/EM-0266.
- *DOE. 1996d. High-level waste inventory, characteristics, generation, and facility assessment for treatment, storage, and disposal alternatives considered in the U.S. Department of Energy.
- *DOE. 1996b. Selected radionuclides important to low-level radioactive waste management: National low-level waste management program. U.S. Department of Energy. DOE/LLW-238.
- DOE. 1996c. Radiological effluents released from U.S. continental tests 1961 through 1992. Nevada: U.S. Department of Energy, Nevada Operations Office. NTIS DOE/NV-317.
- *DOE. 2001a. Derived air concentrations (DAC) for workers from external exposure during immersion in a contaminated atmospheric cloud. U.S. Department of Energy. Code of Federal Regulations. 10 CFR 835, Appendix C. <http://ecfrback.access.gpo.gov/otcqi/otfilter.cgi...d&QUERY=159004&RGN=BAPPCT&SUBSET=SUBSET &FROM=1&ITEM=1>. May 16, 2001.
- *DOE. 2001b. Derived air concentrations (DAC) for controlling radiation exposure to workers at DOE facilities. U.S. Department of Energy. Code of Federal Regulations. 10 CFR 835, Appendix A. <http://ecfrback.access.gpo.gov/otcqi/otilter.cgi...d&QUERY=22008&RGN=BAPPCT&SUBSET=SUBSET &FROM=1&ITEM=1>. May 16, 2001.
- *DOE. 2001d. Timeline/Milestones for the Yucca Mountain Project. <http://www.ymp.gov/timeline/index.htm>. May 10, 2001.
- *DOE. 2001c. Values for establishing sealed radioactive source accountability and radioactive material posting and labeling requirements. U.S. Department of Energy. Code of Federal Regulations. 10 CFR 835, Appendix E. <http://ecfrback.access.gpo.gov/otcqi/otfilter.cgi...d&QUERY=9586&RGN=BAPPCT&SUBSET=SUBSET &FROM=1&ITEM=1>. May 16, 2001.
- Doniach I. 1956. Comparison of the carcinogenic effect of x-irradiation with radioactive iodine on the rat's thyroid. Br J Cancer XI:67-76.

9. REFERENCES

- Doniach I. 1963. Effects including carcinogenesis of I^{131} and x-rays on the thyroid of experimental animals: A review. *Health Phys* 9:1357-1362.
- Doniach I. 1974. Carcinogenic effect of 100, 250 and 500 rad x-rays on the rat thyroid gland. *Br J Cancer* 30:487-495.
- Doniach I, Logothetopoulos JH. 1955. Effects of radioactive iodine on the rat thyroid's function, regeneration and response to goitrogens. *Br J Cancer* IX:117-127.
- Doniach I, Shale DJ. 1976. Biological effects of I^{131} and I^{125} isotopes of iodine in the rat. *J Endocrinol* 71:109-114.
- Doniach I, Williams ED. 1986. Biologic effects of radiation on the thyroid. In: Braverman LE, Utiger RD, eds. *Werner and Ingbar's the thyroid: A fundamental and clinical text*. Philadelphia,PA: Lippincott, 432-444.
- Donovan JW, Adelstein AM. 1974. Multiple-cause analysis of deaths of patients treated with radio-iodine. *Br J Prev Soc Med* 28:69.
- Doshi GR, Joshi SN, Pillai KC. 1991. I^{129} in soil and grass samples around a nuclear reprocessing plant. *J Radioanal Nucl Chem* 155(2):115-127.
- *DOT. 2001a. Shippers-general requirements for shipments and packagings. Table of A1 and A2 values for radionuclides. U.S. Department of Transportation. Code of Federal Regulations. 49 CFR 173.435. <http://ecfrback.access.gpo.gov/otcgui/cfr/otfilter.cgi...TI&QUERY=80992&RGN=BSECCT&SUBSET=SUBSET&FROM=1&ITEM=1>. May 16,2001.
- *DOT. 2001b. List of hazardous substances and reportable quantities. U.S. Department of Transportation. Code of Federal Regulations. 49 CFR 172.101, Appendix A. <http://ecfrback.access.gpo.gov/otcgui/cfr...7&RGN=BAPPCT&SUBSET=SUBSET&FROM=1&ITEM=1>. May 16, 2001.
- Dottorini ME. 1996. Genetic risk assessment after iodine-131 exposure: An opportunity and obligation for nuclear medicine. *J Nucl Med* 37(4):612-615.
- Dottorini ME, Lomuscio G, Mazzucchelli L, et al. 1995. Assessment of female fertility and carcinogenesis after iodine-131 therapy for differentiated thyroid carcinoma. *J Nucl Med* 36:21-27.
- Douglas WS, Alexander JOD. 1975. Dermatitis herpetiformis, iodine compounds and thyrotoxicosis [Letter]. *Br J Dermatol* 92(5):596-598.
- Downie SE, Wasnidge C, Floto F, et al. 1977. Lithium-induced inhibition of I^{125} accumulation by thyroids and growing oocytes of Japanese quail. *Poult Sci* 56:1254-1258.
- Draper A, Lewis J, Malhotra N, et al. 1993. The energy and nutrient intakes of different types of vegetarian: A case for supplements. *Br J Nutr* 69:3-19.
- Dreicer M, Bouville A. 1989. Variability of I-131 Thyroid doses from Nevada weapons testing: Discussion of the most sensitive parameters. *Health Phys* 56(Suppl 1):S51.
- Dreicer M, Bouville A, Wachholz BW. 1990. Pasture practices, milk distribution, and consumption in the continental U.S. in the 1950's. *Health Phys* 59(5):627-636.
- *Dremier S, Coppee F, Delange F, et al. 1996. Clinical review 84: Thyroid autonomy: Mechanism and clinical effects. *J Clin Endocrinol Metab* 81(12):4187-4193.

9. REFERENCES

- Drew B, Barber WP, Williams DG. 1975. The effect of excess dietary iodine on pregnancy mares and foals. *Vet Rec* 97:93-95.
- Driscoll J, Hintz HF, Schryver HF. 1978. Goiter in foals caused by excessive iodine. *J Am Vet Med Assoc* 173:858-859.
- *Drobyshevskaya IM, Astakhova LN, Nalivko AS, et al. 1996. Thyroid cancer in children of Belarus following the Chernobyl accident. In: Nagasaki S, Yamashita S, eds. Nagasaki symposium radiation and human health: Proposal from Nagasaki. Amsterdam, the Netherlands: Elsevier, 49-65.
- Duan SB, Wu HW, Luo JA, et al. 1999. Assessment of renal function in the early stages of nephrotoxicity induced by iodinated contrast media. *Nephron* 83:122-125.
- Duan Y, Zhang H, Jiang X, et al. 1995. A simple, innovative method for the determination of iodide by using gas-phase molecular absorption spectrometry after volatile species evolution. *J Environ Sci Health Part A* 30(7):1577-1593.
- Duffy BJ, Fitzgerald PJ. 1950. Cancer of the thyroid in children: A report of 28 cases. *J Clin Endocrinol Metab* 10:1296-1308.
- *Duffield AJ, Thomson CD, Hill KE, et al. 1999. An estimation of selenium requirements for New Zealanders. *Am J Clin Nutr* 70:896-903.
- Dugrillon A. 1996. Iodolactones and iodoaldehydes-mediators of iodine in thyroid autoregulation. *Exp Clin Endocrinol Diabetes* 104(Suppl 4):41-45.
- Dugrillon A, Gartner R. 1992. The role of iodine and thyroid cell growth. *Thyroidology* 4:31-36.
- Dugrillon A, Gartner R. 1995. Gamma-iodolactones decrease epidermal growth factor-induced proliferation and inositol-1,4,5-triphosphate generation in porcine thyroid follicles-a possible mechanism of growth inhibition by iodide. *Eur J Endocrinol* 132:735-743.
- Dugrillon A, Bechtner G, Uedelhoven WM, et al. 1990. Evidence that an iodolactone mediates the inhibitory effect of iodide on thyroid cell proliferation but not on adenosine 3',5'-monophosphate formation. *Endocrinology* 127(1):337-343.
- Dugrillon A, Uedelhoven WM, Pisarev MA, et al. 1994. Identification of gamma-iodolactone in iodide treated human goiter and its inhibitory effect on proliferation of human thyroid follicles. *Horm Metab Res* 26:465-469.
- Dumas D, Guibout M. 1978. Effect of catecholamines on iodide transport in isolated thyroid cells. *FEBS Lett* 88(2):287-291.
- Dumont JE. 1991. Iodine supply in diet in various European regions and risks of iodine prophylaxis. In: Gerber G, ed. Improvement of practical countermeasures: Preventive medication. Commission of the European Communities. EUR 12256:19-34.
- Dumont JE, Corvilain B, Contempre B. 1994. The biochemistry of endemic cretinism: Roles of iodine and selenium deficiency and goitrogens. *Mol Cell Endocrinol* 100:163-166.
- Dunn AD. 1996. Thyroglobulin retrieval and the endocytic pathway. In: Braverman LW, Utiger RD, eds. Werner and Ingbar's the thyroid: A fundamental and clinical text. Philadelphia, PA: Lippincott-Raven, 81-84.
- Dunn JT. 1993. Iodine supplementation and the prevention of cretinism. *Ann N Y Acad Sci* 678:158-168.

9. REFERENCES

- Dunn JT. 1996. Thyroglobulin: Chemistry and biosynthesis. In: Braverman LE, Utiger RD, eds. Werner and Ingbar's the thyroid: A fundamental and clinical text. Philadelphia, PA: Lippincott-Raven, 85-95.
- Dunn JT, Semigran MJ, Delange F. 1998. The prevention and management of iodine-induced hyperthyroidism and its cardiac features. *Thyroid* 8(1):101-106.
- *Dunn MJ, Dunscombe PB. 1981. Levels of airborne ¹²⁵I during protein labeling. *Radiat Prot Dosim* 1(2):143-146.
- *Dunn JT, Dunn AD. 2001. Update on intrathyroid iodine metabolism. *Thyroid* 11(5):407-414.
- *Dunning DE, Schwarz G. 1981. Variability of human thyroid characteristics and estimates of dose from ingested ¹³¹I. *Health Phys* 40:661-675.
- Dunscombe PB, Dunn MJ, Bhattacharyya AK. 1980. Activated carbon badges as detectors of airborne ¹²⁵I. *Health Phys* 39:717-721.
- *Dupuy C, Virion A, de Sandro V et al. 1991. Mechanism of hydrogen peroxide formation catalyzed by NADPH oxidase in thyroid plasma membrane. *J. Biol. Chem.* 266:3739-3743.
- Dussault JH. 1990. Thyroid antibodies in congenital hypothyroidism. In: ed. Transplacental disorders: Perinatal detection, treatment and management (including pediatric AIDS). Alan R. Liss, Inc., 77-83.
- Dybing E, Sanner T. 1999. Species differences in chemical carcinogenesis of the thyroid gland, kidney and urinary bladder. In: Capen CC, Dybing E, Rice JM, et al., eds. Species differences in thyroid, kidney and urinary bladder carcinogenesis. Lyon, France: International Agency for Research on Cancer, 15-32.
- *Dyck RF, Bear RA, Goldstein MB, et al. 1979. Iodine/iodide toxic reaction: Case report with emphasis on the nature of the metabolic acidosis. *Can Med Assoc J* 120:704-706.
- *Dydek GJ, Blue PW. 1988. Human breast milk excretion of iodine-131 following diagnostic and therapeutic administration to a lactating patient with Graves' disease. *J Nucl Med* 29:407-410.
- *Dyer NC, Brill AB. 1972. Maternal-fetal transport of iron and iodine in human subjects. *Adv Exp Med Biol* 27:351-366.
- *Eadie AS, Horton PW, Hilditch TE. 1980. Monitoring of airborne contamination during the handling of technetium-99m and radioiodine. *Phys Med Biol* 25(6):1079-1087.
- *Eckhardt K, Gocke E, King M-T, et al. 1982. Mutagenic activity of chlorate, bromate, and iodate. *Mutat Res* 97:185.
- Edington GM. 1976. Dietary iodine and risk of breast, endometrial, and ovarian cancer. *Lancet* 1(7974):1413-1414.
- Edmonds CJ, Smith T. 1986. The long-term hazards of the treatment of thyroid cancer with radioiodine. *Br J Radiol* 59:45-51.
- *Eeckhout E, Willemsen M, Deconinck A, et al. 1987. Granulomatous vasculitis as a complication of potassium iodide treatment for Sweet's syndrome. *Acta Derm Venereol (Stockh)* 67(4):362-364.
- Egan RW, Gale PH, Beveridge GC, et al. 1978. Radical scavenging as the mechanism for stimulation of prostaglandin cyclooxygenase and depression of inflammation by lipioic acid and sodium iodide. *Prostaglandins* 16(6):861-869.

9. REFERENCES

- Ehrfeld A, Planas-Bohne F, Lucke-Huhle C. 1986. Amplification of oncogenes and integrated SV40 sequences in mammalian cells by the decay of incorporated iodine-125. *Radiat Res* 108:43-51.
- Einhorn N, Wasserman J, Packalen T. 1970. Cellular autoimmune reactions following radioiodine treatment for hyperthyroidism. *Acta Radiol Ther Phys Biol* 9:225-232.
- *Eipe J, Johnson SA, Kiamko RT, et al. 1968. Hypoparathyroidism following ^{131}I therapy for hyperthyroidism. *Arch Intern Med* 121:270-272.
- *Eisenbud M, ed. 1987. Environmental radioactivity: From natural, industrial, and military sources. New York: Academic Press, Inc.
- *Eisenbud M, Mochizuki Y, Laurer G. 1963. ^{131}I dose to human thyroids in New York City from nuclear tests in 1962. *Health Phys* 9:1291-1298.
- Ekholm R. 1981. Iodination of thyroglobulin: An intracellular or extracellular process? *Mol Cell Endocrinol* 24:141-163.
- *Ekman L, Eriksson A, Fredriksson L, et al. 1967. Studies on the relationship between iodine-131 deposited on pasture and its concentration in milk. *Health Phys* 13:701-706.
- Elliott JE, Scheuhammer AM. 1997. Heavy metal and metallothionein concentrations in seabirds from the Pacific coast of Canada. *Mar Pollut Bull* 34(10):794-801.
- *Elmore D, Phillips FM. 1987. Accelerator mass spectrometry for measurement of long-lived radioisotopes. *Science* 236:543-550.
- *Elmore D, Gove HE, Ferraro R, et al. 1980. Determination of ^{129}I using tandem accelerator mass spectrometry. *Nature* 286:138-140.
- *Elnagar B, Eltom M, Karlsson FA, et al. 1995. The effects of different doses of oral iodized oil on goiter size, urinary iodine, and thyroid-related hormones, *J Clin Endocrinol Metab* 80(3):891-897.
- Elstner EF, Adamczyk R, Kroner R, et al. 1985. [Uptake and biochemical activity of potassium iodide in isolated rabbit eyes.] *Ophthalmologica* 191:122-126. (German)
- Eltom A, Elnagar B, Gebre-Medhin M. 1999. Thyroid hormones and iodine status in Sudanese pregnant women with goitre. *Int J Food Sci Nutr* 50:105-109.
- Emerson CH. 1996. Thyroid disease during and after pregnancy. In: Braverman LE, Utiger RD, eds. *Werner and Ingbar's the thyroid: A fundamental and clinical text*. Philadelphia, PA: Lippincott-Raven, 1021-1031.
- EML. 1992. EML Procedures Manual, 27th ed, Vol 1, February 1992. Environmental Measurements Laboratory, U.S. Department of Energy.
- *EML. 1997. EML Procedures Manual, HASL-300, 28th ed, Vol 1, February 1997. Environmental Measurements Laboratory, U.S. Department of Energy.
- Emrich D. 1977. [Effect of etiroxate hydrochloride on iodine metabolism in man.] *Arzneim Forsch* 27(2):422-426. (German)
- Emrich D, Schicha H, Facorro U, et al. 1980. Correlation of iodine excretion to hormone concentrations in different states of thyroid function. *J Mol Med* 4:183-189.

9. REFERENCES

- *Endo T, Kaneshige M, Nakazato M, et al. 1997. Thyroid transcription factor-1 activated the promoter activity of rat thyroid Na⁺/I⁻ symporter gene. *Mol Endocrinol* 11:1747-1755.
- *Eng PHK, Cardona GR, Fang S-L, et al. 1999. Escape from the acute Wolff-Chaikoff effect is associated with a decrease in thyroid sodium/iodide symporter messenger ribonucleic acid and protein. *Endocrinology* 140:3404-3410.
- *Engler D, Burger AG. 1984. The deiodination of the iodothyronines and of their derivatives in man. *Endocrine Rev* 5(2):151-184.
- Engler H, Taurog A, Luthy C, et al. 1983. Reversible and irreversible inhibition of thyroid peroxidase-catalyzed iodination by thioureylenes. *Endocrinology* 112(1):86-95.
- *Envirocare. 2001. Envirocare receives first low-level shipments from LEHR. <http://www.envirocareutah.com>. May 22, 2001.
- EPA. 1974. The behavior of ¹³¹I in an artificial rumen and in the stimulated fluids of the abomasum and intestine. Las Vegas, NV: U.S. Environmental Protection Agency. NERC-LV-539-32.
- EPA. 1975. ¹³¹I levels in cow's milk following ingestion of contaminated alfalfa or sudan grass. Las Vegas, NV: U.S. Environmental Protection Agency, Environmental Monitoring and Support Laboratory, Monitoring Systems Research and Development Division. EMSL-LV-539-1.
- EPA. 1976. Interim radiochemical methodology for drinking water. Cincinnati, OH: U.S. Environmental Protection Agency, Environmental Monitoring and Support Laboratory. EPA 600/4-75-008.
- EPA. 1978. Follow-up of patients receiving diagnostic doses of ¹³¹I during childhood. Research Triangle Park, NC: U.S. Environmental Protection Agency, Office of Research and Development, Health Effects Research Laboratory. EPA-600/1-78-059.
- EPA. 1980. Method 902.0. Prescribed procedures for measurement of radioactivity in drinking water. Cincinnati, OH: U.S. Environmental Protection Agency, Environmental Monitoring and Support Laboratory. EPA-600/4-80-032.
- *EPA. 1983. Method 345.1. Methods for chemical analysis of water and wastes. Cincinnati, OH: U.S. Environmental Protection Agency, Environmental Monitoring and Support Laboratory. EPA-600/4-79-020.
- *EPA. 1986. Iodination of nutrients in the presence of chlorine based disinfectants used in drinking water treatment. Research Triangle Park, NC: U.S. Environmental Protection Agency, Office of Research and Development, Health Effects Research Laboratory. NTIS PB87180683.
- EPA. 1990. Interim methods for development of inhalation reference concentrations. Washington, DC: U.S. Environmental Protection Agency, Office of Health and Environmental Assessment, Office of Research and Development, Environmental Criteria and Assessment Office. EPA 600/8-90/066A.
- EPA. 1994. Estimating radiogenic cancer risks. Washington, DC: U.S. Environmental Protection Agency, Office of Radiation and Indoor Air. EPA 402-R-93-076. NTIS PB96-139860.
- EPA. 1997a. Environmental radiation data report 79: July - September 1994. Montgomery, AL: U.S. Environmental Protection Agency, National Air and Radiation Environmental Laboratory. NTIS EPA-402-R-97-002.
- EPA. 1997b. Environmental radiation data report 80: October - December 1994. Montgomery, AL: U.S. Environmental Protection Agency, National Air and Radiation Environmental Laboratory. NTIS EPA-402-R-97-003.

9. REFERENCES

- EPA. 1997c. Environmental radiation data report 81: January - March 1995. Montgomery, AL: U.S. Environmental Protection Agency, National Air and Radiation Environmental Laboratory. NTIS EPA-402-R-97-004.
- EPA. 1997d. Environmental radiation data report 82: April - June 1995. Montgomery, AL: U.S. Environmental Protection Agency, National Air and Radiation Environmental Laboratory. NTIS EPA-402-R-97-005.
- EPA. 1997e. U.S. Environmental Protection Agency. National primary drinking water regulations: Analytical methods for radionuclides; Final Rule and Proposed Rule. Fed Reg 62(43):10167-10174.
- *EPA. 1997f. Exposure factors handbook. Vol 1. General factors. Washington, DC: U.S. Environmental Protection Agency. EPA/600/P-95/002Fa.
- *EPA. 1997g. Health Effects Assessment Summary Tables. FY-1997 Update. Office of Research and Development, Office of Emergency and Remedial Response. Washington, DC: U.S. Environmental Protection Agency. EPA/540/R-97/036. NTIS PB 97-921199.
- *EPA. 1998. United States Environmental Protection Agency. Health risks from low-level environmental exposure to radionuclides. Office of Radiation and Indoor Air. EPA 402-R-97-014.
- *EPA. 2001a. Annual possession quantities for environmental compliance. U.S. Environmental Protection Agency. Code of Federal Regulations. 40 CFR 61, Appendix E, Table 1. <http://ecfrback.access.gpo.gov/otcgi/cfr...1&RGN=BAPPCT&SUBSET=SUBSET&FROM=1&ITEM=1> May 16, 2001.
- *EPA. 2001b. Iodine production subcategory. U.S. Environmental Protection Agency. Code of Federal Regulations. 40 CFR 415, Subpart AQ. <http://ecfrback.access.gpo.gov/otcgi/cfr...1&RGN=BAPPCT&SUBSET=SUBSET&FROM=1&ITEM=1>. May 16, 2001.
- *ERD 1993. Environmental Radiation Data Report 75, July-September 1993. Environmental Protection Agency (available at website <http://www.epa.gov/narel/erdonline.htm>).
- *ERD 1997. Environmental Radiation Data Report 91, July-September 1997. Environmental Protection Agency (available at website <http://www.epa.gov/narel/erdonline.htm>).
- ERDA. 1978. Iodine-129 in thyroids and tellurium isotopes in meteorites by neutron activation analysis. U.S. Energy Research and Development Administration. NTIS COO24501.
- Ericson LE, Nilsson M. 1996. Effects of insulin-like growth factor I on growth, epithelial barrier and iodide transport in polarized pig thyrocyte monolayers. *Eur J Endocrinol* 135:118-127.
- *Ermans AM, Camus M. 1972. Modifications of thyroid function induced by chronic administration of iodide in the presence of >>autonomous<< thyroid tissue. *Acta Endocrinol* 70:463-475.
- *Eskandari S, Loo DD, Dai G, et al. 1997. Thyroid Na⁺/I⁻ symporter: Mechanism, stoichiometry, and specificity. *J Biol Chem* 272(43):27230-27238.
- *Eskin BA. 1970. Iodine metabolism and breast cancer. *Trans N Y Acad Sci* 32(8):911-947.
- Eskin BA. 1976. Dietary iodine and cancer risk [Letter]. *Lancet* 2(7989):807.
- Eskin BA. 1977. Iodine and mammary cancer. *Adv Exp Med Biol* 91:293-304.

9. REFERENCES

- Eskin BA, Merion JA, Stamieszkin I. 1976. Estrogen-iodine interaction in breast dysplasia. [Abstract]. Proc Am Assoc Cancer Res 17:169.
- Eskin BA, Shuman R, Krouse T, et al. 1975. Rat mammary gland atypia produced by iodine blockade with perchlorate. Cancer Res 35:2332-2339.
- *Esselstyn CB, Schumacher OP, Eversman J, et al. 1982. Hyperparathyroidism after radioactive iodine therapy for Graves disease. Surgery 92:811-813.
- Etling N, Gehin-Fouque F. 1984. Iodinated compounds and thyroxine binding to albumin in human breast milk. Pediatr Res 18(9):901-903.
- *Etling N, Vielh JP. 1979. [Iodine overloads in amniotic fluids.] Nouv Presse Med 8:1647-1648. (French)
- Etling N, Gehin-Fouque F, Vielh JP, et al. 1979. The iodine content of amniotic fluid and placental transfer of iodinated drugs. Obstet Gynecol 53(3):376-380.
- *Etling N, Padovani E, Gehin-Fouque F, et al. 1983. Iodine and thyroid hormone levels in serum and urine of full term newborn infants. Helv Paediatr Acta 38:117-122.
- Evans PMS, Webster J, Evans WD, et al. 1998. Radioiodine treatment in unsuspected pregnancy. Clin Endocrinol 48:281-283.
- *Evans TC, Kretzschmar RM, Hodges RE, et al. 1967. Radioiodine uptake studies of the human fetal thyroid. J Nucl Med 8:157-165.
- Exss R, Graewe B. 1974. Congenital athyroidism in the newborn infant from intra-uterine radioiodine action. Biol Neonate 24:289-291.
- Fagin JA. 1996. Molecular pathogenesis. In: Braverman LE, Utiger RD, eds. Werner and Ingbar's the thyroid: A fundamental and clinical text. Philadelphia, PA: Lippincott-Raven, 909-916.
- Fanelli A, Berlin WK, Grollman EF. 1995. Inhibition of iodide transport in rat thyroid cells using *N*-substituted anthranilic acid derivatives. Thyroid 5(3):223-230.
- Fatourechi V. 1996. Localized myxedema and thyroid acropachy. In: Braverman LE, Utiger RD, eds. Werner and Ingbar's the thyroid: A fundamental and clinical text. Philadelphia, PA: Lippincott-Raven, 553-558.
- *Fawcett DM, Kirkwood S. 1953. The mechanism of the antithyroid action of the iodide ion and of the "aromatic" thyroid inhibitors. Journal of Biological Chemistry 204:787-796.
- FDA. 1973. Scientific literature reviews on generally recognized as safe (GRAS) food ingredients - Iodine and iodine salts. Washington, DC: U.S. Food and Drug Administration. PB 223 849.
- *FDA. 1974. Iodine in foods: Chemical methodology and sources of iodine in the human diet. Washington, DC: U.S. Food and Drug Administration, Bureau of Foods, Division of Nutrition. PB-233-559.
- *FDA. 1978. Potassium iodide as a thyroid-blocking agent in a radiation emergency. U.S. Food and Drug Administration. Federal Register 43:58798-800.
- FDA. 1989a. A follow-up study of persons who had iodine-131 and other diagnostic procedures during childhood and adolescence. Rockville, MD: U.S. Food and Drug Administration, Public Health Service, Center for Devices and Radiological Health. FDA 89-8276.

9. REFERENCES

- *FDA. 1989b. Iodine toxicity. Washington, DC: U.S. Food and Drug Administration, Center for Food Safety and Applied Nutrition. NTIS PB89 183016.
- *FDA. 1998b. Accidental radioactive contamination of human food and animals feeds: Recommendations for state and local agencies. U.S. Department of Health and Human Services. Food and Drug Administration. Center for Devices and Radiological health. Rockville, MD 20850. August 13, 1998.
- *FDA. 2000a. Drug products containing certain active ingredients offered over-the-counter (OTC) for certain uses. U.S. Food and Drug Administration. Code of Federal Regulations. 21 CFR 310.545. <http://frewebgate.access.gpo.gov/cgi-bin/...SECTION=545&YEAR=2000&YEAR=2000&TYPE=TEXT>. May 16, 2001.
- *FDA. 2000b. Drugs; recommended warning and caution statements. U.S. Food and Drug Administration. Code of Federal Regulations. 21 CFR 369.20. <http://frewebgate.access.gpo.gov/cgi-bin/...SECTION=20&YEAR=2000&YEAR=2000&TYPE=TEXT>. May 16, 2001.
- *FDA. 2000c. Food additives permitted for direct addition to food for human consumption. U.S. Food and Drug Administration. Code of Federal Regulations. 21 CFR 172.375. <http://frewebgate.access.gpo.gov/cgi...172&SECTION=375&YEAR=2000&TYPE=TEXT>. March 06, 2001.
- *FDA. 2000d. Indirect food additives: Adjuvants, production aids, and sanitizers. Sanitizing solutions. U.S. Food and Drug Administration. Code of Federal Regulations. 21 CFR 178.1010. <http://frewebgate.access.gpo.gov/cgi-bin/...ART=178&SECTION=1010&YEAR=2000&TYPE=TEXT>. May 16, 2001.
- *FDA. 2000e. Nutritional labeling of dietary supplements. U.S. Food and Drug Administration. Code of Federal Regulations. 21 CFR 101.36. <http://frewebgate.access.gpo.gov/cgi-bin/...&PART=101&SECTION=36&YEAR=2000&TYPE=TEXT>. May 16, 2001.
- *FDA. 2000f. Nutritional quality guidelines for foods. U.S. Food and Drug Administration. Code of Federal Regulations. 21 CFR 104.20. <http://frewebgate.access.gpo.gov/cgi-bin/...&PART=104&SECTION=20&YEAR=2000&TYPE=TEXT>. May 16, 2001.
- *FDA. 2000g. Requirements regarding certain radioactive drugs. U.S. Food and Drug Administration. Code of Federal Regulations. 21 CFR 310.503. <http://ecfrback.access.gpo.gov/otc/cfr...3&RGN=BSECCT&SUBSET=SUBSET&FROM=1&ITEM=1>. May 16, 2001.
- *FDA. 2000h. Sources of radiation used for inspection of food, for inspection of packaged food, and for controlling food processing. U.S. Food and Drug Administration. Code of Federal Regulations. 21 CFR 179.21. <http://ecfrback.access.gpo.gov/otc/cfr...8&RGN=BSECCT&SUBSET=SUBSET&FROM=1&ITEM=1> May 16, 2001.
- *FDA. 2000i. Trace minerals added to animal feed. U.S. Food and Drug Administration. Code of Federal Regulations. 21 CFR 582.80. <http://frewebgate.access.gpo.gov/cgi-bin/...&PART=582&SECTION=80&YEAR=2000&TYPE=TEXT>. May 16, 2001.
- *FDA. 2001a. Nutrients. U.S. Food and Drug Administration. <http://www.verity.fda.gov/opacom/laws/fdrgact.htm>. March 6, 2001.
- *FDA. 2001b. U.S. Food and Drug Administration. Code of Federal Regulations. 21CFR101.9.
- *FEDRIP. 2000. Federal Research in Progress. Dialog Information Services, Inc. Palo Alto, CA.

9. REFERENCES

- Feek CM, Sawers JS, Irvine WJ, et al. 1980. Combination of potassium iodide and propranolol in preparation of patients with Graves' disease for thyroid surgery. *N Engl J Med* 302:883-885.
- Feinendegen LE, Henneberg P, Tisljar-Lentulis G. 1977. DNA strand breakage and repair in human kidney cells after exposure to incorporated iodine-125 and cobalt-60 gamma rays. *Curr Top Radiat Res Q* 12:436-452.
- Feldkamp J, Pascher E, Perniok A, et al. 1999. Fas-mediated apoptosis is inhibited by TSH and iodine in moderate concentrations in primary human thyrocytes *in vitro*. *Horm Metab Res* 31:355-358.
- *Fenner FD, Martin JE. 1997. Behavior of Na¹³¹I and meta(¹³¹I) iodobenzylguanidine (MIBG) in municipal sewerage. *Health Phys* 73:333-339.
- Ferguson MM, Alexander WD, Connell JMC, et al. 1984. Peroxidase activity in relation to iodide. 17beta-oestradiol and thioreylene drug uptake in human polymorphoneutrophils. *Biochem Pharmacol* 33(5):757-762.
- Ferriols Lisart F, Rodilla Calvelo F, Ciges Sanmartin E, et al. 1995. [Use of Lugol to protect thyroid from a radiologic exposure.] *Farm Clin* 12:683-685. (Spanish)
- Field JB, Dekker A, Titus G, et al. 1979. In vitro and in vivo refractoriness to thyrotropin stimulation of iodine organification and thyroid hormone secretion. *J Clin Invest* 64:265-271.
- Fike JR, Gobbel GT, Marton LJ, et al. 1994. Radiation brain injury is reduced by the polyamine inhibitor alpha-difluoromethylornithine. *Radiat Res* 138:99-106.
- *Filetti S, Rapoport B. 1983. Evidence that an organic iodine attenuates the adenosine 3'5' monophosphate response to thyrotropin stimulation in thyroid tissue by an action at or near the sdenylate cyclase catalytic unit. *Endocrinology* 113:1608.
- *Filistovic V, Nedveckaite T. 1998. Reaction pathways involving ¹²⁷I and ¹³¹I in the atmospheric air. *Environ Phys* 20(2):5-12.
- *Finkelstein R, Jacobi M. 1937. Fatal iodine poisoning: A clinico-pathologic and experimental study. *Adv Intern Med* 60:1283-1296.
- Fischer PWF, Giroux A. 1993. Iodine content of Canadian retail milk samples II. After the ethylenediamine dihydroiodide ban. *Food Res Int* 26:277-281.
- Fischer PWF, Campbell JS, Giroux A. 1989. Effect of dietary iodine on autoimmune thyroiditis in the BB Wistar rat. *J Nutr* 119:502-507.
- Fischman RA, Fairclough GF, Cheigh JS. 1978. Iodide and negative anion gap [Letter]. *N Engl J Med* 298(18):1035-1036.
- Fish RE, Swanson EW. 1982. Effects of excessive intakes of iodine upon growth and thyroid function of growing Holstein heifers. *J Dairy Sci* 65:605-610.
- Fisher DA. 1989. Upper limit of iodine in infant formulas. *J Nutr* 119:1865-1868.
- Fisher DA. 1996. Thyroid physiology in the perinatal period and during childhood. In: Braverman LE, Utiger RD, eds. *Werner and Ingbar's the thyroid: A fundamental and clinical text*. Philadelphia, PA: Lippincott-Raven, 974-983.
- *Fisher DA, Oddie TH, Burroughs JC. 1962. Thyroidal radioiodine uptake rate measurement in infants. *Am J Dis Child* 103:738-749.

9. REFERENCES

- *Fisher DA, Oddie TH, Epperson D. 1965. Effect of increased dietary iodide on thyroid accumulation and secretion in euthyroid Arkansas subjects. *J Clin Endocrinol* 25:1580-1590.
- Fisher NS, Fowler SW, Boisson F, et al. 1999. Radionuclide bioconcentration factors and sediment partition coefficients in Arctic seas subject to contamination from dumped nuclear wastes. *Environ Sci Technol* 33:1979-1982.
- Fisher WD, Voorhess ML, Gardner LI. 1965. Congenital hypothyroidism in infant following maternal I¹³¹ therapy: With a review of hazards of environmental radioisotope contamination. *J Pediatr* 62:132-146.
- Fisherman EW, Cohen GN. 1977. A vascular test to detect iodide hypersensitivity (intolerance). *Ann Allergy* 38:163-168.
- *Fjalling M, Dackenberg A, Hedman I, et al. 1983. An evaluation of the risk of developing hyperparathyroidism after ¹³¹I treatment for thyrotoxicosis. *Acta Chir Scand Suppl* 149:681-686.
- Floyer C, Wilkinson JD. 1988. Treatment of venous leg ulcers with cadexomer iodine with particular reference to iodine sensitivity. *Acta Chir Scand Suppl* 544:60-61.
- Folb PI, Graham Dukes MN. 1990. Thyroid and antithyroid drugs. In: *Drug safety in pregnancy*. Cape Town, South Africa: University of Cape Town, 305-314.
- Foley TP. 1991. Maternally transferred thyroid disease in the infant: Recognition and treatment. In: Bercu BB, Shulman DI, eds. *Advances in perinatal thyroidology*. New York, NY: Plenum Press, 209-226.
- *Foley TP. 1992. The relationship between autoimmune thyroid disease and iodine intake: A review. *Endokrynol Pol* 43 (Suppl 1):53-69.
- Foley TPJ. 1996. Congenital hypothyroidism. In: Braverman LE, Utiger RD, eds. *Werner and Ingbar's the thyroid: A fundamental and clinical text*. Philadelphia, PA: Lippincott-Raven, 988-994.
- Foley TP, Charron M. 1997. Radioiodine treatment of juvenile Graves disease. *Exp Clin Endocrinol Diabetes* 105(Suppl 4):61-65.
- *Fomon SJ. 1966. Body composition of the infant: Part I: The male "reference infant". In: Falkner F, ed. *Human development*. Philadelphia, PA: WB Saunders, 239-246.
- *Fomon SJ, Haschke F, Ziegler EE, et al. 1982. Body composition of reference children from birth to age 10 years. *Am J Clin Nutr* 35:1169-1175.
- Fontana B, Curti G, Biggi A, et al. 1980. The incidence of hypothyroidism after radioactive iodine (¹³¹I) therapy for autonomous hyperfunctioning thyroid nodule evaluated by means of life-table method. *J Nucl Med Allied Sci* 24(1-2):85-91.
- *Forbes. GB, Bruining GJ. 1976. Urinary creatinine excretion and lean body mass. *Am J Clin Nutr* 29:1359-1366.
- Foster HD. 1987. Disease family trees: The possible roles of iodine in goitre, cretinism, multiple sclerosis, amyotrophic lateral sclerosis, Alzheimer's and Parkinson's diseases and cancer of the thyroid, nervous system and skin. *Med Hypotheses* 24:249-263.
- Foster HD. 1993. The iodine-selenium connection: Its possible roles in intelligence, cretinism, sudden infant death syndrome, breast cancer and multiple sclerosis. *Med Hypotheses* 40:61-65.
- *Fradkin JE, Wolff J. 1983. Iodide-induced thyrotoxicosis. *Medicine* 62(1):1-20.

9. REFERENCES

- Fragu P, Othman SB, Nataf BM. 1979. Effect of PTU added to a low iodine diet on peroxidase activity and other parameters of thyroid function in rats. *Acta Endocrinol* 91:462-472.
- *Franceschi S. 1998. Iodine intake and thyroid carcinoma-a potential risk factor. *Exp Clin Endocrinol Diabetes* 106(Suppl 3):S38-S44.
- *Franceschi S, Dal Maso L. 1999. Hormonal imbalances and thyroid cancers in humans. In: Capen CC, Dybing E, Rice JM, et al., eds. *Species differences in thyroid, kidney and urinary bladder carcinogenesis*. Lyon, France: International Agency for Research on Cancer, 33-43.
- Franceschi S, Talamini R, Fassina A, et al. 1990. Diet and epithelial cancer of the thyroid gland. *Tumori* 76:331-338.
- Francis AR, Shetty TK, Bhattacharya RK. 1988. Modifying role of dietary factors on the mutagenicity of aflatoxin B₁: In vitro effect of trace elements. *Mutat Res* 199:85-93.
- Francois PJ, Szmigielski M, De Rouck A, et al. 1966. [Electrophysiologic and histologic study of experimental tapeto-retinal degeneration evoked by sodium iodide. I. Electrophysiologic study.] *Ophthalmologica* 152:131-148. (French)
- Franklyn J, Sheppard M. 1992. Radioiodine for hyperthyroidism: Perhaps the best option. *Br Med J* 305:727-728.
- Franklyn JA, Daykin J, Holder R, et al. 1995. Radioiodine therapy compared in patients with toxic nodular or Graves' hyperthyroidism. *Q J Med* 88:175-180.
- Franklyn JA, Maisonneuve P, Sheppard MC, et al. 1998. Mortality after the treatment of hyperthyroidism with radioactive iodine. *N Engl J Med* 338:712-718.
- Franklyn JA, Maisonneuve P, Sheppard M, et al. 1999. Cancer incidence and mortality after radioiodine treatment for hyperthyroidism: A population-based cohort study. *Lancet* 353:2111-2115.
- *Freeman M, Guiliani M, Schwartz E, et al. 1969. Acute thyroiditis, thyroid crisis, and hypocalcemia following radioactive iodine therapy. *N Y State J Med* 69(14):2036-2041.
- Fregly MJ, McCarthy JS. 1973. Effect of diuretics on renal iodide excretion by humans. *Toxicol Appl Pharmacol* 25:289-298.
- Freidman NB, Catz B. 1996. The reactions of euthyroid and hyperthyroid glands to radioactive iodine. *Arch Pathol Lab Med* 120:660-661.
- Franceschi S, Levi F, Negri E, et al. 1991. Diet and thyroid cancer: A pooled analysis of four European case-control studies. *Indian J Cancer* 48:395-398.
- Franceschi S, Talamini R, Fassina A, et al. 1990. diet and epithelial cancer of the thyroid gland. *Tumori* 76:331-338.
- Freitas JE, Swanson DP, Gross MD, et al. 1979. Iodine-131: Optimal therapy for hyperthyroidism in children and adolescents? *J Nucl Med* 20:847-850.
- Fritzsche H, Benzer W, Furlan W, et al. 1993. [Prophylaxis of iodine-induced thyrotoxicosis after coronary angiography.] *Acta Med Austriaca* 20:13-17. (German)
- From E, Thomsen K. 1974. Dermatitis herpetiformis: A case provoked by iodine. *Br J Dermatol* 91(2):221-224.

9. REFERENCES

From GLA, Lawson VG. 1997. Solitary thyroid nodule: Concepts in diagnosis and treatment. In: Falk SA, ed. Thyroid disease: Endocrinology, surgery, nuclear medicine, and radiotherapy. Philadelphia, PA: Lippincott-Raven Publishers, 411-429.

*Fuge R. 1987. Iodine in the environment: Its distribution and relationship to human health. In: Hemphill DD, ed. Trace substances in environmental health. Columbia, Mo: Curators of the University of Missouri, 74-87.

*Fujimori K, Takahashi T, Ohtomo H, et al. 1996. Preliminary medical findings of the Marshall Islands nationwide thyroid study. In: Nagataki S, Yamashita S, eds. Nagasaki symposium radiation and human health: Proposal from Nagasaki. Amsterdam, the Netherlands: Elsevier, 167-173.

*Fujiwara H, Tatsumi K, Miki K, et al. 1997. Congenital hypothyroidism caused by a mutation in the Na⁺/I⁻ symporter. *Nat Genet* 16:124-125.

*Fujiwara H, Tatsumi K-I, Miki K, et al. 1998. Recurrent T354P mutation of the Na⁺/I⁻ symporter in patients with iodide transport defect. *J Clin Endocrinol Metab* 83(8):2940-2943.

Fujiwara S, Ezaki H, Sposto R, et al. 1990. Hyperparathyroidism among atomic bomb survivors in Hiroshima, 1986-88. *DCBN 22-0058403 (Upstate) TR 8-90:1-12*.

Fukuda H, Yasuda N, Greer MA. 1975. Acute effects of thyroxine, triiodothyronine, and iodide on thyrotropin secretion. *Endocrinology* 97:924-931.

Fukui M, Fujikawa Y, Satta N. 1996. Factors affecting interaction of radioiodine and iodate species with soil. *J Environ Radioact* 31(2):199-216.

Fulop M. 1971. Hypoparathyroidism after ¹³¹I therapy. *Ann Intern Med* 75(5):808.

Furr AK, Parkinson TF, Heffron CL, et al. 1978. Elemental content of tissues and excreta of lambs, goats, and kids fed white sweet clover growing on fly ash. *J Agric Food Chem* 26:847-851.

Furrer J, Dillman H-G (1986): Apparatus for detecting iodine isotopes. (to Kernforschungszentrum Karlsruhe G.m.b.H.) Application: Germany 4,626,692, 2 Dec 1986. United States Patent 4,626,692, issued 2 Dec 1986.

*Furudate S, Nishimaki T, Muto T. 1997. ¹²⁵I uptake competing with iodine absorption by the thyroid gland following povidone-iodine skin application. *Exp Anim* 46(3):197-202.

*Gabay JJ, Paperiello CJ, Goodyear S, et al. 1974. A method for determining iodine-129 in milk and water. *Health Phys* 26:89-96.

*Gabler H-E, Heumann KG. 1993. Determination of atmospheric iodine species using a system of specifically prepared filters and IDMS. *Fresenius J Anal Chem* 345:53-59.

Gadzhiev KM. 1990. [A case of anaphylactic shock in response to the topical application of 5 percent alcohol tincture of iodine.] *Azerb Med Zh* 4:56-57. (Azerbaijani)

*Gaffney GW, Gregerman RI, Shock NW. 1962. Relationship to age to the thyroidal accumulation, renal excretion and distribution of radioiodide in euthyroid man. *J Clin Endocrinol Metab* 22:784-794.

Gaitan E, Cooksey RC, Meydrech EF, et al. 1989. Thyroid function in neonates from goitrous and nongoitrous iodine-sufficient areas. *J Clin Endocrinol Metab* 69(2):359-363.

*Galina MP, Avnet NL, Einhorn A. 1962. Iodides during pregnancy: An apparent cause of neonatal death. *N Engl J Med* 267:1124-1127.

9. REFERENCES

- Galla JH, Kotchen TA, Luke RG. 1977. Failure of sodium iodide loading to inhibit renin in the rat. *Proc Soc Exp Biol Med* 154:30-32.
- Gambal D, Quackenbush FW. 1968. Essential fatty acids, plasma protein bound iodine, and the thyroid gland. *Proc Soc Exp Biol Med* 127(4):1137-1138.
- Gambert SR. 1996. Intrinsic and extrinsic variables. In: Braverman LE, Utiger RD, eds. *Werner and Ingbar's the thyroid: A fundamental and clinical text*. Philadelphia, PA: Lippincott-Raven, 254-259.
- Gao F, Fu C, Zhang C, et al. 1992. [Further studies on the carcinogenic effects of radioiodine in rats.] *Zhong Fan Yixue Yu Fanghu Zazhi* 12(4):249-252. (Chinese)
- Garcia Pascual L, Simo R, Mesa J, et al. 1992. [Myelodysplastic syndrome following radioiodine treatment of differentiated carcinoma of the thyroid [Letter]. *Rev Clin Esp* 191(3):169-170. (Spanish)
- *Gardner DF, Centor RM, Utiger RD. 1988. Effects of low dose oral iodide supplementation on thyroid function in normal men. *Clin Endocrinol* 28:283-288.
- Gardner DF, Mars DR, Thomas RG, et al. 1986. Iodine retention and thyroid dysfunction in patients on hemodialysis and continuous ambulatory peritoneal dialysis. *Am J Kidney Dis* VII(6):471-476.
- Gardner DF, Rothman J, Utiger RD. 1979. Serum thyroglobulin in normal subjects and patients with hyperthyroidism due to Graves' disease: Effects of T3, iodide, ¹³¹I and antithyroid drugs. *Clin Endocrinol* 11:585-594.
- *Garijo MAG, Quintana JAD, Gonzalez PB, et al. 1996. Anaphylactic shock following povidone. *Ann Pharmacother* 30:37-40.
- Gartner R, Dugrillon A, Bechtner G. 1996. Evidence that iodolactones are the mediators of growth inhibition by iodine on the thyroid. *Acta Med Austriaca* 23:47-51.
- Gartner R, Greil W, Demharter R, et al. 1985. Involvement of cyclic AMP, iodide and metabolites of arachidonic acid in the regulation of cell proliferation of isolated porcine thyroid follicles. *Mol Cell Endocrinol* 42:145-155.
- *Gautier MA. 1983. *Manual of Analytical methods for radiobioassay*, DOE Report No. LA-9763-M (National Technical Information Services), Springfield, VA.
- *Gavin LA, Livermore BM, Cavalieri RR, et al. 1980. Serum concentration, metabolic clearance, and production rates of 3,5,3'-triiodothyroacetic acid in normal and athyreotic man. *J Clin Endocrinol Metab* 51(3):529-534.
- Gedik O, Ozdemir T, Akalin S. 1991. Discordant hypothyroxinemia and hypertriiodothyroninemia in treated patients with hyperthyroid Graves' disease and toxic multinodular goiter. *Isr J Med Sci* 27:361-364.
- Geisthovel W. 1984. [Hyperthyroidism after administration iodine-containing eyedrops.] *Dtsch Med Wochenschr* 109(34):1304-1305. (German)
- *Gélinas Y, Iyengar GV, Barnes RM. 1998. Total iodine in nutritional and biological reference materials using neutron activation analysis and inductively coupled plasma mass spectrometry. *Fresenius J Anal Chem* 362:483-488.
- Gembicki M. 1996. Physiological basis of iodine prophylaxis in case of a nuclear accident. In: *Radiodosimetry and preventative measures in the event of a nuclear accident*. Austria: International Atomic Energy Agency, 87-100. IAEA-TECDOC-893.

9. REFERENCES

- *Gembicki M, Stozharov AN, Arinchin AN, et al. 1997. Iodine deficiency in Belarusian children as a possible factor stimulating the irradiation of the thyroid gland during the Chernobyl catastrophe. *Environ Health Perspect Suppl* 105(6):1487-1490.
- *Georgitis WJ, McDermott MT, Kidd GS. 1993. An iodine load from water-purification tablets alters thyroid function in humans. *Mil Med* 158:794-797.
- Germani MS, Zoller WH. 1988. Vapor-phase concentrations of arsenic, selenium, bromine, iodine, and mercury in the stack of a coal-fired power plant. *Environ Sci Technol* 22:1079-1085.
- *Germani MS, Gokmen I, Sigleo AC, et al. 1998. Concentrations of elements in the antional bureau of standards' bituminous and subbituminous coal standard reference materials. *Anal Chem* 52:240-245.
- Geselowitz DA, McManaway MM, Hofer KG, et al. 1995. Low-let radiotoxicity from incorporated ^3H or ^{125}I during the cell cycle: Implications for mechanisms of high-let damage. In: Fuciarelli AF, Zimbrick JD, eds. *Radiation damage in DNA: Structure/function relationships at early times*. Columbus,OH: Battelle Press, 223-230.
- *Ghahremani GG, Hoffer PB, Oppenheim BE, et al. 1971. New normal values for thyroid uptake of radioactive iodine. *JAMA* 217(3):337-339.
- Gibberd M, McMillan M, Staffurth JS. 1974. Thyrotropin (T.S.H.) after iodine-131 therapy. *Lancet* 1(7865):1048.
- Gibbs RA, Camakaris J, Hodgson GS, et al. 1987. Molecular characterization of ^{125}I decay and x-ray-induced HPRT mutants in CHO cells. *Int J Radiat Biol* 51(2):193-199.
- *Gilbert ES, Tarone R, Bouville A, et al. 1998. Thyroid cancer rates and ^{131}I doses from Nevada atmospheric nuclear bomb tests. *J Natl Cancer Inst* 90(21):1654-1660.
- Gilbert-Dreyfus Z, Gali P. 1958. Cataracte tetanique apres IRA-therapie. *Sem Hop* 34:1301-1304.
- Gilchrist B. 1997. Should iodine be reconsidered in wound management? *J Wound Care* 6(3):148-150.
- Gillespie FC, Orr JS, Greig WR. 1970. Microscopic dose distribution from ^{125}I in the toxic thyroid gland and its relation to therapy. *Br J Radiol* 43:40-47.
- Gimeno EJ, Walinder G, Feinstein RE, et al. 1986. Effect of high ^{131}I doses to the thyroid gland on tumorigenicity of ^{90}Sr and ^{90}Y in mice. *Acta Radiol Oncol* 25:4-6.
- Ginsberg J, Murray PG. 1991. Stimulation of TSH-mediated iodide organification in porcine thyroid cells following protein kinase C inhibition. In: Gordon A, Gross J, Hennemann G, eds. *Progress in thyroid research*. Rotterdam, the Netherlands: Balkema, 599-602.
- Ginsberg J, Matowe W, Murray PG. 1993. Enhancement of thyrotropin-stimulated iodide organification in porcine thyroid cells after protein kinase-C inhibition. *Endocrinology* 132(4):1815-1819.
- Gittoes NJL, Franklyn JA. 1995. Drug-induced thyroid disorders. *Drug Saf* 13(1):46-55.
- Gittoes NJL, Franklyn JA. 1998. Hyperthyroidism: Current treatment guidelines. *Drugs* 55(4):543-553.
- *Giwerzman A, Carlsen E, Keiding N, et al. 1993. Evidence for increasing incidence of abnormalities of the human testis: A review. *Environ Health Perspect Suppl* 101(2):65-71.
- Glanzmann C, Horst W. 1979. [Treatment of thyrotoxicosis with 125-iodine: Results in 93 patients 3 to 5 years after treatment, and comparison with 131-iodine therapy.] *Strahlentherapie* 155:1-5. (German)

9. REFERENCES

- Glanzmann C, Horst W. 1980. Iodine-125 and iodine-131 in the treatment of hyperthyroidism. *Clin Nucl Med* 5(7):325-333.
- *Glasscock RF. 1954. The secretion of a single tracer dose of labeled iodine in the milk of the lactating cow. *J Dairy Res* 21:318.
- *Glazebrook GA. 1987. Effect of decicurie doses of radioactive iodine 131 on parathyroid function. *Am J Surg* 154:368-373.
- Glennon JA, Gordon ES, Sawin CT. 1972. Hypothyroidism after low-dose ¹³¹I treatment of hyperthyroidism. *Ann Intern Med* 76:721-723.
- Glick PL, Guglielmo BJ, Winter ME, et al. 1990. Iodine toxicity secondary to continuous povidone-iodine mediastinal irrigation in dogs. *J Surg Res* 49:428-434.
- Glinoe D. 1999. What happens to the normal thyroid during pregnancy? *Thyroid* 9(7):631-635.
- *Glinoe D. 2001. Pregnancy and iodine. *Thyroid* 11(5):139-149.
- Globel B, Globel H, Andres C. 1985. The risk of hyperthyroidism following an increase in the supply of iodine. *J Hosp Infect* 6(Supplement):201-204.
- Gluzman BE, Coleoni AH, Targovnik HM, et al. 1977. Effects of amiodarone on thyroid iodine metabolism in vitro. *Acta Endocrinol* 85:781-790.
- Gobbel GT, Marton LJ, Lamborn K, et al. 1991. Modification of radiation-induced brain injury by alpha-difluoromethylornithine. *Radiat Res* 128:306-315.
- *Goh K. 1981. Radioiodine treatment during pregnancy: Chromosomal aberrations and cretinsim associated with maternal iodine-131 treatment. *J Am Med Womens Assoc* 36(8):262-265.
- Goldberg RC, Chaikoff IL. 1951. Development of thyroid neoplasms in the rat following a single injection of radioactive iodine. *Proc Soc Exp Biol Med* 76:563-566.
- Goldberg REA, Miraldi F. 1987. Radionuclide imaging of potassium iodide-induced sialadenitis. *Clin Nucl Med* 12:370-372.
- Golden MHN. 1982. Trace elements in human nutrition. *Hum Nutr Clin Nutr* 36C:185-202.
- Goldman M, Grau TJ. 1974. A comparative study on the influence of dimethyl sulfoxide on iodine metabolism in male Long-Evans rats and male CF₁ mice. *Toxicol Appl Pharmacol* 29:340-347.
- Goldman M, Landry D. 1976. The effect of povidone-iodine on thyroid function in rats. *Toxicol Appl Pharmacol* 35:341-346.
- *Goldman MB, Maloof F, Monson RR, et al. 1988. Radioactive iodine therapy and breast cancer: A follow-up study of hyperthyroid women. *Am J Epidemiol* 127(5):969-980.
- *Goldschmidt VM. 1958. *Geochemistry*. Oxford University Press, London, pp.602-620.
- Goldsmith JR, Grossman CM, Morton WE, et al. 1999. Juvenile hypothyroidism among two populations exposed to radioiodine. *Environ Health Perspect* 107(4):303-308.
- Goldstein R, Hart IR. 1983. Follow-up of solitary autonomous thyroid nodules treated with ¹³¹I. *N Engl J Med* 309(24):1473-1476.

9. REFERENCES

- Golstein J, Dumont JE. 1996. Cytotoxic effects of iodide on thyroid cells: Difference between rat thyroid FRTL-5 cell and primary dog thyrocyte responsiveness. *J Endocrinol Invest* 19:119-126.
- Golstein P, Abramow M, Dumont JE, et al. 1992. The iodide channel of the thyroid: A plasma membrane vesicle study. *Am J Physiol* 263(32):C590-C597.
- Gomez JM, Virgili N, Soler J, et al. 1989. Transient hypothyroidism after iodine-131 treatment of Graves' disease. *Thyroidology* 3:149-152.
- Gomez N, Gomez JM, Orti A, et al. 1995. Transient hypothyroidism after iodine-131 therapy for Grave's disease. *J Nucl Med* 36:1539-1542.
- Gomez N, Gomez JM, Villabona C, et al. 1998. Transient hypothyroidism after iodine-131 therapy for Graves' disease. *Clin Endocrinol* 48:526-527.
- Goncharov AT, Ametov AS. 1977. [The effect of chrome on the thyroid in rats kept on an iodine-deficient diet.] *Probl Endokrinol (Mosk)* 23(6):59-61. (Russian)
- *Gonzalez AJ. 1998. Radioactive residues of the cold war period. A radiological legacy. *IAEA Bulletin* 40(4):2-11.
- Goolden AWG, Stewart JSW. 1986. Long-term results from graded low dose radioactive iodine therapy for thyrotoxicosis. *Clin Endocrinol* 24:217-222.
- Goolden AWG, Kam KC, Fitzpatrick ML, et al. 1986. Oedema of the neck after ablation of the thyroid with radioactive iodine. *Br J Radiol* 59:583-586.
- *Gordon CM, Rowitch DH, Mitchell ML, et al. 1995. Topical iodine and neonatal hypothyroidism. *Arch Pediatr Adolesc Med* 149:1336-1339.
- Gorman CA. 1995. Radioiodine therapy does not aggravate Graves' opthalmopathy. *J Clin Endocrinol Metab* 80:340-342.
- Gorman CA. 1999. Radioiodine and pregnancy. *Thyroid* 9(7):721-726.
- *Gorodinskiy SM, Yes'kova-Soskovets LS, Rokhlin MI, et al. 1979. Penetration of gaseous I131 through human skin. Ohio: Foreign Technology Division, Wright-Patterson Air Force Base. NTIS ADA087882.
- Gorowski T, Gabryelewicz MB, Jastrzebska H. 1992. [Anaplastic thyroid carcinoma developed after treatment of "hot" thyroid nodule with radioiodine.] *Endokrynol Pol* 43(3):308-313. (Russian)
- Gossage AAR, Neal FE, Ross CMD, et al. 1984. Cases of carcinoma of thyroid following iodine-131 therapy for hyperthyroidism. *Oncology* 41:8-12.
- Gotoh T, Ito A, Yamada K, et al. 1996a. [Occurrence of time and dose-dependent rat thyroid tumors induced by radioiodine (131I) and fission neutron (252Cf).] *Nagasaki Igakkai Zasshi* 71:375-379. (Japanese)
- Gotoh T, Watanabe H, Tanizaki M, et al. 1996b. Promotion of thyroid tumors in F344 male rats given a low iodine diet after treatment with n-methyl-n-nitrosourea in their drinking water. *J Toxicol Pathol* 9:191-197.
- *Goyens P, Golstein J, Nsombola B et al. 1987. Selenium deficiency as a possible factor in the pathogenesis of myxoedematous cretinism. *Acta Endocrinol.* 114:497-502.

9. REFERENCES

- Graham GD, Burman KD. 1986. Radioiodine treatment of Graves' disease. *Ann Intern Med* 105:900-905.
- *Gramlich JW, Murphy TJ. 1989. Determination of trace level iodine in biological and botanical reference materials by isotope dilution mass spectrometry. *J Res Nat Inst Stand Technol* 94(4):215-220.
- Granter SR, Cibas ES. 1997. Cytologic findings in thyroid nodules after ¹³¹I treatment of hyperthyroidism. *Am J Clin Pathol* 107:20-25.
- Gray B, Galton VA. 1974. The transplacental passage of thyroxine and foetal thyroid function in the rat. *Acta Endocrinol* 75:725-733.
- Gray HW, McKillop JH, McGurk FM, et al. 1982. Carcinoma of trachea following iodine-125 therapy for thyrotoxicosis. *Lancet* 1:688.
- *Green DM, Edge SB, Penetrante RB, et al. 1995. In situ breast carcinoma after treatment during adolescence for thyroid cancer with radioiodine. *Med Pediatr Oncol* 24:82-86.
- *Green HG, Gareis FJ, Shepard TH, et al. 1971. Cretinism associated with maternal sodium iodide I 131 therapy during pregnancy. *Am J Dis Child* 122:247-249.
- Green WL. 1970. Relationships between the effects of iodide, methimazole and thyrotropin on the intermediary metabolism of bovine thyroid slices. *Endocrinology* 86:708-712.
- *Green WL. 1996. Antithyroid compounds. In: Braverman LE, Utiger RD, eds. *Werner and Ingbar's the thyroid: A fundamental and clinical text*. Philadelphia, PA: Lippincott-Raven, 266-276.
- *Green WL, Ingbar SH. 1961. The peripheral metabolism of tri- and tetraiodothyroacetic acids in man. *J Clin Endocrinol Metab* 21:1548-1565.
- Greer MA. 1996. Thyrotoxicosis of extrathyroid origin. In: Braverman LE, Utiger RD, eds. *Werner and Ingbar's the thyroid: A fundamental and clinical text*. Philadelphia, PA: Lippincott-Raven, 592-594.
- Greig WR, Smith JFB, Gillespie FC, et al. 1969. Iodine-125 treatment for thyrotoxicosis. *Lancet* 1:755-757.
- Greig WR, Smith JFB, Orr JS, et al. 1970. Comparative survivals of rat thyroid cells *in vivo* after ¹³¹I, ¹²⁵I and X irradiations. *Br J Radiol* 43:542-548.
- Gresham DG, Wool MS. 1984. Hypoparathyroidism after radioiodine therapy for Graves' disease: Is its incidence increasing? *Postgrad Med* 75(4):299-305.
- Griem ML, Malkinson FD. 1967. Some studies on the effects of radiation and radiation modifiers on growing hair. *Radiat Res* 30:431-443.
- Gross MD, Shapiro B, Sisson JC. 1999. Radioiodine therapy for thyrotoxicosis. *Rays* 24(2):334-347.
- Grossman CM, Nussbaum RH, Morton WE. 1996. Hypothyroidism and spontaneous abortions among Hanford, Washington, downwinders. *Arch Environ Health* 51(3):175-176.
- Gruffat D, Gonzalez S, Mauchamp J, et al. 1991. Phenol red: An inhibitor of thyroglobulin iodination in cultured porcine thyroid cells. *Mol Cell Endocrinol* 81:195-203.
- Gruffat D, Venot N, Marriq C, et al. 1992. Thyroid hormone synthesis in thyroglobulin secreted by porcine thyroid cells cultured on porous bottom chambers: Effect of iodide. *Endocrinology* 131(6):2921-2927.

9. REFERENCES

- Grumbach MM, Werner SC. 1956. Transfer of thyroid hormone across the human placenta at term. *J Clin Endocrinol Metab* 16:1392-1395.
- Grunditz T, Sundler F. 1996. Autonomic nervous control: Adrenergic, cholinergic, and peptidergic regulation. In: Braverman LE, Utiger RD, eds. *Werner and Ingbar's the thyroid: A fundamental and clinical text*. Philadelphia, PA: Lippincott-Raven, 247-253.
- Grunwald F, Palmedo H, Biersack HJ. 1995. Unilateral iodine-131 uptake in the lactating breast. *J Nucl Med* 36(9):1724-1725.
- Gu Y, Ciu Y, Liu X. 1984. Changes in peripheral T and B lymphocytes of rat after intravenous injection of ¹³¹I. *Chin Med J* 97(10):773-776.
- Gumarnik S. 1988. Skin preparation and spinal headache. *Anaesthesia* 43(12):1057-1058.
- Gupta GS, Chopra VK. 1977. Biological damage in testis by iodine-125 in partially blocked thyroid of rats. *Radiat Environ Biophys* 14:147-152.
- Gupta GS, Chopra VK. 1980. Biological damage in spleen by iodine-125 in potassium perchlorate blocked thyroid of rats. *Strahlentherapie* 156:579-582.
- Gupta SM, Goyal PK, Dev PK. 1981. Weight changes in mice after intrauterine treatment with MPG (2-mercaptopropionylglycine) against I¹³¹ irradiation. *Experientia* 37:898-899.
- Gutiérrez S, Carbonell E, Galofre P, et al. 1995. A cytogenetic follow-up study of thyroid cancer patients treated with ¹³¹I. *Cancer Lett* 91:199-204.
- *Gutiérrez S, Carbonell E, Galofre P, et al. 1998a. The alkaline single-cell gel electrophoresis (SCGE) assay applied to the analysis of radiation-induced DNA damage in thyroid cancer patients treated with ¹³¹I. *Mutat Res* 413:111-119.
- Gutierrez S, Carbonell E, Galofre P, et al. 1998b. Application of the single cell gel electrophoresis (SCGE) assay to the detection of DNA damage induced by ¹³¹I treatment in hyperthyroidism patients. *Mutagenesis* 13(1):95-98.
- Gutierrez S, Carbonell E, Galofre P, et al. 1999. Low sensitivity of the sister chromatid exchange assay to detect the genotoxic effects of radioiodine therapy. *Mutagenesis* 14(2):221-226.
- *Guzelian PS, Henry CJ, Olin SS, eds. 1992. *Similarities and differences between children and adults: Implications for risk assessment*. Washington, DC: International Life Sciences Institute Press.
- Haffenden GP, Blenkinsopp WK, Ring NP, et al. 1980. The potassium iodide patch test in dermatitis herpetiformis in relation to treatment with a gluten-free diet and dapsone. *Br J Dermatol* 102:313-317.
- *Hagmar L, Persson-Moschos M, Akesson B, et al. 1998. Plasma levels of selenium, selenoprotein P and glutathione peroxidase and their correlations to fish intake and serum levels of thyrotropin and thyroid hormones: A study on Latvian fish consumers. *Eur J Clin Nutr* 52:796-800.
- Haggard DL, Stowe HD, Conner GH, et al. 1980. Immunologic effects of experimental iodine toxicosis in young cattle. *Am J Vet Res* 41(4):539-543.
- Halford DK, Markham OD. 1984. Iodine-129 in waterfowl muscle from a radioactive leaching pond complex in southeastern Idaho. *Health Phys* 46(6):1259-1263.
- Hall MT. 1973. Chemical antagonism by iodine of the pharmacological activity of sympathomimetic amines. *J Pharm Pharmacol* 25(11):923-925.

9. REFERENCES

- Hall PE, Holm LE. 1996. Thyroid cancer incidence among Swedish patients exposed to diagnostic doses of iodine-131: A preliminary report. In: Radiodosimetry and preventative measures in the event of a nuclear accident. Austria: International Atomic Energy Agency, 55-63. IAEA-TECDOC-893.
- Hall PFL. 1991. Cancer risks in humans after iodine-131 exposure. *Diss Abstr Int C* 53-03C:458.
- Hall P, Holm L-E. 1995a. Cancer in iodine-131 exposed patients. *J Endocrinol Invest* 18:147-149.
- Hall P, Holm L-E. 1995b. Cancer incidence and mortality after iodine-131 therapy for hyperthyroidism. *Adv Chem Ser* 243:103-112.
- Hall P, Holm L-E. 1997. Late consequences of radioiodine for diagnosis and therapy in Sweden. *Thyroid* 7(2):205-208.
- *Hall P, Berg G, Bjelkengren G, et al. 1992a. Cancer mortality after iodine-131 therapy for hyperthyroidism. *Int J Cancer* 50:886-890.
- Hall P, Boice JDJ, Berg G, et al. 1992b. Leukemia incidence after iodine-131 exposure. *Lancet* 340(8810):1-4.
- Hall P, Holm L-E, Lundell G, et al. 1991. Cancer risks in thyroid cancer patients. *Br J Cancer* 64:159-163.
- Hall P, Holm L-E, Lundell G, et al. 1992c. Tumors after radiotherapy for thyroid cancer. *Acta Oncol* 31(4):403-407.
- Hall P, Lundell G, Holm L-E. 1993. Mortality in patients treated for hyperthyroidism with iodine-131. *Acta Endocrinol* 128:230-234.
- *Hall P, Furst CJ, Mattsson A, et al. 1996a. Thyroid nodularity after diagnostic administration of iodine-131. *Radiat Res* 146:673-682.
- *Hall P, Mattsson A, Boice JDJ. 1996b. Thyroid cancer after diagnostic administration of iodine-131. *Radiat Res* 145:86-92.
- *Hall R, Turner-Warwick M, Doniach D. 1966. Autoantibodies in iodide goitre and asthma. *Clin Exp Immunol* 1:285-296.
- Halimi NS. 1961. Thyroidal iodide transport. *Vitam Horm* 19:133-163.
- Halimi NS, Gifford TH, Glesne RE. 1967. Further observations concerning the effect of actinomycin D on thyroidal iodide transport in rats. *Endocrinology* 81:893-898.
- Halimi NS, King LT, Widner RR, et al. 1958. Renal excretion of radioiodide in rats. *Am J Physiol* 193:379-385.
- Halimi NS, Nissen WM, Scranton JR. 1969. The kinetics of the enhancement of thyroidal iodide accumulation after actinomycin D administration. *Endocrinology* 84:943-945.
- Halnan KE. 1958. The radioiodine uptake of the human thyroid in pregnancy. *Clin Sci* 17:281-290.
- Halnan KE. 1983. Risks from radioiodine treatment of thyrotoxicosis. *Br Med J* 287:1821-1822.
- Halnan KE. 1992. Leukemia after iodine-131 exposure [Letter]. *Lancet* 340:437.

9. REFERENCES

- Halpern S, Alazraki N, Littenberg R, et al. 1973. ^{131}I thyroid uptakes: Capsule versus liquid. *J Nucl Med* 14(7):507-510.
- Hamby DM, Benke RR. 1999. Uncertainty of the iodine-131 ingestion dose conversion factor. *Radiat Prot Dosim* 82(4):245-256.
- *Hamill GC, Jarman JA, Wynne MD. 1961. Fetal effects of radioactive iodine therapy in a pregnant woman with thyroid cancer. *Am J Obstet Gynecol* 81(3):1018-1023.
- *Hamilton TE, van Belle G, LoGerfo JP. 1987. Thyroid neoplasia in Marshall Islanders exposed to nuclear fallout. *JAMA* 258(5):629-636.
- *Han JS. 1992. Effects of various chemical compounds on spontaneous and hydrogen peroxide-induced reversion in strain TA104 of salmonella typhimurium. *Mutat Res* 266(2):77-84.
- Hanauer G, Schroth HJ. 1990. [Estimation of the radioiodine dose necessary for complete ablation of the thyroid gland in male Wistar rats.] *Zentralbl Veterinarmed A* 37:747-751. (German)
- *Handelsman DJ, Turtle JR. 1983. Testicular damage after radioactive iodine (I-131) therapy for thyroid cancer. *Clin Endocrinol* 18:465-472.
- Handelsman DJ, Conway AJ, Donnelly PE, et al. 1980. Azoospermia after iodine-131 treatment of thyroid carcinoma. *Br Med J* 281:1527.
- *Handl J, Pfau A. 1989. Long-term transfer of I-129 into the food chain. *Sci Total Environ* 85:245-252.
- *Handl J, Pfau A, Huth FW. 1990. Measurements of ^{129}I in human and bovine thyroids in Europe-Transfer of ^{129}I into the food chain. *Health Phys* 58(5):609-618.
- Hang J, Rillema JA. 1998. Possible involvement of PI3K in prolactin-stimulated milk product formation and iodide transport in mouse mammary explants. *Proc Soc Exp Biol Med* 219:154-159.
- *Hansch C, Leo A, eds. 1995. Exploring QSAR: Fundamentals and applications in chemistry and biology. Washington, DC: American Chemical Society.
- *Harach HR, Williams ED. 1995. Thyroid cancer and thyroiditis in the goitrous region of Salta, Argentina, before and after iodine prophylaxis. *Clin Endocrinol* 43:701-706.
- *Harach HR, Escalante DA, Onativia A, et al. 1985. Thyroid carcinoma and thyroiditis in an endemic goitre region before and after iodine prophylaxis. *Acta Endocrinol* 108:55-60.
- Harapanhalli RS, Narra VR, Yaghamai V, et al. 1994. Vitamins as radioprotectors *in vivo* II. Protection by vitamin A and soybean oil against radiation damage caused by internal radionuclides. *Radiat Res* 139:115-122.
- Harden RM, Alexander WD, Chisholm CJS, et al. 1968. The salivary iodide trap in nontoxic goiter. *J Clin Endocrinol Metab* 28:117-120.
- Harden RM, Harrison MT, Alexander WD. 1963. Phosphate excretion and parathyroid function after radioiodine therapy and thyroidectomy. *Clin Sci* 25:27-36.
- Harley NH, Harley JH. 1986. Fallout inhalation [Letter]. *Health Phys* 50(3):422.
- Harrington RM, Shertzer HG, Bercz JP. 1985. Effects of ClO_2 on the absorption and distribution of dietary iodide in the rat. *Fundam Appl Toxicol* 5:672-678.

9. REFERENCES

- Harris PF, Sanchez JF, Mode DG. 1970. Iodide mumps [Letter]. *JAMA* 213(13):2271-2272.
- Harris SJ, Gilmore A. 1980. Penetration of protective gloves as a route of intake for tritiated water and ¹²⁵I-labeled sodium iodide solution. *Phys Med Biol* 25(6):1089-1094.
- *Harrison J. 1963. The fate of radioiodine applied to human skin. *Health Phys* 9:993-1000.
- Harrison LC, Buckley JD, Martin FIR. 1977. Use of a computer-based postal questionnaire for the detection of hypothyroidism following radioiodine therapy for thyrotoxicosis. *Aust N Z J Med* 7:27-32.
- Harrop JS, Hopton MR, Lazarus JH. 1981. Concentration of serum thyroid hormone binding proteins after ¹³¹I treatment of hyperthyroidism. *Ann Clin Biochem* 18:211-214.
- Hartman PE, Morgan RW. 1982. Nitrate/nitrite/iodide/ascorbate ingestion and gastric/esophageal cancer mortality. *Environ Mutagen* 4(3):339-340.
- Harvey RD, Metcalfe RA, Morteo C, et al. 1995. Acute pre-tibial myxedema following radioiodine therapy for thyrotoxic Graves' disease. *Clin Endocrinol* 42:657-660.
- Hasan SS, Mazumdar S, Prasad GC, et al. 1984. The effect of radioactive iodine on brain acetylcholine and serotonin in normal and stress subjected rats. *Folia Biol* 32(3):201-208.
- Hashizume K, Akasu F, Takazawa K, et al. 1976. The inhibitory effect of acute administration of excess iodide on the formation of adenosine 3',5'-monophosphate induced by thyrotropin in mouse thyroid lobes. *Endocrinology* 99:1463-1468.
- Hashizume K, Ichikawa K, Komiya I, et al. 1984. Thyrotropin-induced acceleration of calcium efflux from mouse thyroid: Evidence for inhibition by excess iodide. *Endocrinology* 114:1672-1677.
- *Hassan AI, Aref GH, Kassem AS. 1968. Congenital iodide-induced goitre with hypothyroidism. *Arch Dis Child* 43:702-704.
- Hauben M. 1993. Seizures after povidone-iodine mediastinal irrigation [Letter]. *N Engl J Med* 328(5):355.
- Hawe P, Francis HH. 1962. Pregnancy and thyrotoxicosis. *Br Med J* 2:817-822.
- *Hawkes WC, Keim NL. 1995. The effect of selenium (Se) on triiodothyronine (T₃) and weight changes in healthy men in a metabolic research unit. *FASEB J* 9(5):A160.
- Hay ID, Morris JC. 1996. Toxic adenoma and toxic multinodular goiter. In: Braverman LE, Utiger RD, eds. *Werner and Ingbar's the thyroid: A fundamental and clinical text*. Philadelphia, PA: Lippincott-Raven, 566-572.
- Hayek A. 1978. Thyroid storm following radioiodine for thyrotoxicosis. *J Pediatr* 93(6):978-980.
- Hayek A, Brooks M. 1975. Neonatal hyperthyroidism following intrauterine hypothyroidism. *J Pediatr* 87(3):446-448.
- Hayek A, Chapman EM, Crawford JD. 1970. Long-term results of treatment of thyrotoxicosis in children and adolescents with radioactive iodine. *N Engl J Med* 283(18):949-953.
- Hays MT. 1979. Kinetics of the human thyroid trap: Effects of iodide, thyrotropin, and propylthiouracil. *J Nucl Med* 20:944-949.
- Hays MT. 1982. Hypothyroidism following iodine-131 therapy. *J Nucl Med* 23(2):176-179.

9. REFERENCES

- Hays MT. 1984. Compartmental models for human iodine metabolism. *Math Biosci* 72:317-335.
- *Hays MT. 1993. Colonic excretion of iodide in normal human subjects. *Thyroid* 3(1):31-35.
- Hays MT, Wesselosky B. 1973. Simultaneous measurement of thyroidal trapping ($^{99m}\text{TcO}_4^-$ and binding $^{131}\text{I}^-$): Clinical and experimental studies in man. *J Nucl Med* 14(11):785-792.
- Hays MT, Carr LJ, Turrel JM. 1987. Effect of sampling site on early kinetics of blood radioiodide and pertechnetate. *Am J Physiol* 253(16):E691-E700.
- *Hays MT, Hsu L, Kohatsu S. 1992. Transport of the thyroid hormones across the feline gut wall. *Thyroid* 2:45-56.
- *HazDat. 2001. Agency of Toxic Substances and Disease Registry (ATSDR), Atlanta, GA. April 2001.
- Heath CW, Fullerton HW. 1935. The rate of absorption of iodide and glycine from the gastrointestinal tract in normal persons and in disease conditions. *J Clin Invest* 14:475-481.
- *Heaton RW, Rahn KA, Lowenthal DH. 1990. Determination of trace elements, including regional tracers, in Rhode Island precipitation. *Atmos Environ* 24A(1):147-153.
- *Hedrick WR, DiSimone RN, Keen RL. 1986. Radiation dosimetry from breast milk excretion of radioiodine and pertechnetate. *J Nucl Med* 27:1569-1571.
- Hegedus L, Perrild H, Poulsen LR, et al. 1983. The determination of thyroid volume by ultrasound and its relationship to body weight, age, and sex in normal subjects. *J Clin Endocrinol Metab* 56(2):260-263.
- *Heinemann K, Vogt KJ. 1980. Measurements of the deposition of iodine onto vegetation and of the biological half-life of iodine on vegetation. *Health Phys* 39:463-474.
- Held KR, Cruz ME, Moncayo F. 1990. Clinical pattern and the genetics of the fetal iodine deficiency disorder (endemic cretinism): Results of a field study in highland Ecuador. *Am J Med Genet* 35:85-90.
- Helds A, Lehrs E, Bolsheva J, et al. 1980. Function of thyroid and hypothalamic-pituitary-thyroid axis in radioiodine treated thyrotoxic patients. *Endokrinologie* 76(3):345-350.
- Hemken RW. 1980. Estimates of human iodine consumption and implications for human health. Annual meeting of the National Mastitis Council, Vol. 19, 81-86.
- Hempelmann LH, Hall WJ, Phillips M, et al. 1975. Neoplasms in persons treated with x-rays in infancy: Fourth survey in 20 years. *J Natl Cancer Inst* 55(3):519-530.
- Hendrich CE, Jackson WJ, Porterfield SP. 1984. Behavioral testing of progenies of Tx (hypothyroid) and growth hormone-treated Tx rats: An animal model for mental retardation. *Neuroendocrinology* 38:429-437.
- Hengstler JG, Bockisch A, Fuchs J, et al. 1997. Increase in DNA single-strand break rejoining by continuous exposure of human mononuclear blood cells to radioiodine (^{131}I) *in vitro*. *Int J Radiat Biol* 72(5):607-613.
- Henrichs K, Mueller-Brunecker G, Paretzke HG. 1983. [Radiation exposure of the thyroid on incorporation of iodine isotopes: Age dependence and reliability of dose factors.] GSF-Ber S 960:1-56. (German)
- Henzen C, Buess M, Brander L. 1999. [Iodine-induced thyrotoxicosis ("fodbasedow")]: An up-to-date clinical picture.] *Schweiz Med Wochenschr* 129(17):658-664. (German)

9. REFERENCES

- *Hermus AR, Huysmans DA. 2000. The epidemiology of thyroid diseases. In: Braverman LE, Utiger RD, eds. *Werner and Ingbar's the thyroid: A fundamental and clinical text*. 8th ed. Philadelphia, PA: Lippincott-Raven, 474-482.
- Hernberg S, Kurppa K, Ojajarvi J, et al. 1983. Congenital malformations and occupational exposure to disinfectants: A case-referent study. *Scand J Work Environ Health* 9:55.
- Herrera E, Escobar del Rey F, Morreale de Escobar G. 1968. Mechanism of goitrogenesis by very low doses of propylthiouracil and the role of iodine intake. *Acta Endocrinol* 59:529-544.
- Hershman JM. 1996. Trophoblastic tumors. In: Braverman LE, Utiger RD, eds. *Werner and Ingbar's the thyroid: A fundamental and clinical text*. Philadelphia, PA: Lippincott-Raven, 573-576.
- Hershman JM, Lee H-Y, Sugawara M, et al. 1988. Human chorionic gonadotropin stimulates iodide uptake, adenylate cyclase, and deoxyribonucleic acid synthesis in cultured rat thyroid cells. *J Clin Endocrinol Metab* 67:74-79.
- Hetzel BS. 1994. Iodine deficiency and fetal brain damage. *N Engl J Med* 331(26):1770-1771.
- Heufelder AE, Hofbauer LC. 1996. How iodide gets access to thyrocytes: Molecular details on the thyroid iodide transporter. *Eur J Endocrinol* 135:34-36.
- Hiasa Y, Kitahori Y, Kato Y, et al. 1987. Potassium perchlorate, potassium iodide, and propylthiouracil: Promoting effect on the development of thyroid tumors in rats treated with n-bis(2-hydroxypropyl)-nitrosamine. *Jpn J Cancer Res* 78:1335-1440.
- Hildebrandt JD, Halimi NS. 1981. Intrathyroidally generated iodine: The role of transport in its utilization. *Endocrinology* 106(3):842-849.
- Hillman D. 1980. Chronic iodide toxicity in dairy herds. *J Dairy Sci* 63(Suppl 1):67-68.
- Hillman D, Curtis AR. 1980. Chronic iodine toxicity in dairy cattle: Blood chemistry, leukocytes, and milk iodide. *J Dairy Sci* 63:55-63.
- Himsworth RL. 1985. Hyperthyroidism with a low iodine uptake. *Clin Endocrinol Metab* 14(2):397-415.
- Hindie E, Bourahla K, Petiet A, et al. 1997. Microscopic distribution of radioactive iodine, and side-effects of thyroid protection in iodine-deficient new-born rats: Insights into the aftermath of the Chernobyl accident. *J Trace Microprobe Tech* 15(4):701-705.
- Hintze G, Emrich D, Richter K, et al. 1988. Effect of voluntary intake of iodinated salt on prevalence of goitre in children. *Acta Endocrinol* 117:333-338.
- Hnilica P, Langer P. 1983. Incidence of malignity in cystic nontoxic nodular goitre. *Acta Endocrinol Suppl* 252:14-15.
- Hobel M, Asmar F, Kruger FW, et al. 1967. Uber die ausscheidung von ¹³¹J- in das broncho-trachaalsekret von laboratoriums-tieren und deren beeinflussung durch pharmaka (II). *Arch Int Pharmacodyn* 168(1):116-140.
- Hodges RE, Evans TC, Bradbury JT, et al. 1955. The accumulation of radioactive iodine by human fetal thyroids. *J Clin Endocrinol Metab* 15(6):661-667.
- Hodgson-Jones IS. 1970. Clioquinol and iodine metabolism. *Trans St Johns Hosp Dermatol Soc* 56(1):51-53.

9. REFERENCES

- *Hoecker WH, Machta L. 1990. Meteorological modeling of radioiodine transport and deposition within the continental United States. *Health Phys* 59(5):603-617.
- *Hoel DG, Davis DL, Miller AB, et al. 1992. Trends in cancer mortality in 15 industrialized countries, 1969-1986. *J Natl Cancer Inst* 84(5):313-320.
- Hofbauer LC, Rafferteder M, Janssen OE, et al. 1995. Insulin-like growth factor I messenger ribonucleic acid expression in porcine thyroid follicles is regulated by throtropin and iodine. *Eur J Endocrinol* 132:605-610.
- Hofer KC, Keough G, Smith JM. 1977. Biological toxicity of auger emitters: Molecular fragmentation versus electron irradiation. *Curr Top Radiat Res Q* 12:335-354.
- Hofer KG, Van Loon N, Schneiderman MH, et al. 1992. The paradoxical nature of DNA damage and cell death induced by ^{125}I decay. *Radiat Res* 130:121-124.
- Hofer KG, van Loon N, Schneiderman MH, et al. 1993. Targets for radiation-induced cell death: Target replication during the cell cycle evaluated in cells exposed to X-rays or ^{125}I decays. *Int J Radiat Biol* 64(2):205-216.
- Hoffman DA. 1976. Delayed effects of therapeutic levels of iodine-131 mortality experience in patients treated with hyper thyroidism. *Radiat Res* 67(3):556.
- Hoffman DA, McConahey WM. 1983. Breast cancer following iodine-131 therapy for hyperthyroidism. *J Natl Cancer Inst* 70(1):63-67.
- Hoffman DA, McConahey WM, Diamong EL, et al. 1982a. Mortality in women treated for hyperthyroidism. *Am J Epidemiol* 115(2):243-254.
- Hoffman DA, McConahey WM, Fraumeni JFJ, et al. 1982b. Cancer incidence following treatment of hyperthyroidism. *Int J Epidemiol* 11(3):218-224.
- Hoffman FO. 1978. A review of measured values of the milk transfer coefficient (f_m) for iodine. *Health Phys* 35(2):413-416.
- Hoffman FO, Dunning DEJ. 1979. Some uncertainties associated with parameter values and models in U.S. NRC regulatory guide 1. 109: Prediction of the ^{131}I thyroid dose to children via the grass-cow-milk pathway [Abstract]. *Health Phys* 37(6):848-849.
- Hoffman L, De Luise M, Martin FIR. 1981. Fallibility of postal questionnaire follow-up for detection of hypothyroidism after iodine-131 therapy. *Med J Aust* 1:303-304.
- Hohenwald H, Ramm C. 1970. [Iodide sialadenitis and lipids in guinea pigs.] *Acta Histochem Bd* 36(2):414-416. (German)
- Holbreich M. 1982. Asthma and other allergic disorders in pregnancy. *Am Fam Physician* 25(3):187-192.
- *Holland JZ. 1963. Physical origin and dispersion of radioiodine. *Health Physics* 9:1095.
- Hollingsworth DR, Austin E. 1969. Observations following I^{131} for Graves disease during first trimester of pregnancy. *South Med J* 62:1555-1556.
- Hollowell JG, Hannon WH. 1997. Teratogen update: Iodine deficiency, a community teratogen. *Teratology* 55:389-405.

9. REFERENCES

Holm J-E, Lundell G, Wallinder G. 1980. Incidence of malignant thyroid tumors in humans after exposure to diagnostic doses of iodine-131. I. Retrospective cohort study. *J Natl Cancer Inst* 64(5):1055-1059.

Holm L-E. 1980. Thyroid treatment and its possible influence on occurrence of malignant tumors after diagnostic ¹³¹I. *Acta Radiol Oncol* 19:455-459.

Holm LE. 1982a. Carcinogenic and genetic risks of ionizing radiation with special reference to radioiodines. In: *Thyroid disease*. France: Pergamon Press, 159-186.

Holm L-E. 1982b. Changing annual incidence of hypothyroidism after iodine-131 therapy for hyperthyroidism, 1951-1975. *J Nucl Med* 23:108-112.

Holm LE. 1984. Malignant disease following iodine-131 therapy in Sweden. In: Boice JDJ, Fraumeni JFJ, eds. *Radiation carcinogenesis: Epidemiology and biological significance*. New York: Raven Press, 263-271.

Holm L-E. 1985. Thyroid cancer after exposure to radioiodine. *Strahlenschutz ForschPrax* 25:36-56.

Holm L-E. 1991. Cancer risks after diagnostic doses of ¹³¹I with special reference to thyroid cancer. *Cancer Detect Prev* 15(1):27-30.

Holm L-E, Hall PFL. 1993. Swedish iodine-131 study. *Radiat Res* 133(1):134-135.

Holm LE, Dahlqvist I, Israelsson A, et al. 1980a. Malignant thyroid tumors after iodine-131 therapy. *N Engl J Med* 303(4):188-191.

Holm LE, Eklund G, Lundell G. 1980b. Incidence of malignant thyroid tumors in humans after exposure to diagnostic doses of iodine-131. II. Estimation of thyroid gland size, thyroid radiation dose, and predicted versus observed number of malignant thyroid tumors. *J Natl Cancer Inst* 63(6):1221-1224.

*Holm L-E, Hall P, Wiklund K, et al. 1991. Cancer risk after iodine-131 therapy for hyperthyroidism. *J Natl Cancer Inst* 83:1072-1077.

Holm L-E, Lundell G, Israelsson A, et al. 1982. Incidence of hypothyroidism occurring long after iodine-131 therapy for hyperthyroidism. *J Nucl Med* 23:103-107.

Holm LE, Lundell G, Walinder G. 1980c. Incidence of malignant thyroid tumors in humans after exposure to diagnostic doses of iodine-131. I. Retrospective cohort study. *J Natl Cancer Inst* 64(5):1055-1059.

Holm L-E, Wiklund KE, Lundell GE, et al. 1988. Thyroid cancer after diagnostic doses of iodine-131: A retrospective cohort study. *J Natl Cancer Inst* 80:1132-1138.

*Holm L-E, Wiklund DE, Lundell GE, et al. 1989. Cancer risk in population examined with diagnostic doses of ¹³¹I. *J Natl Cancer Inst* 81:302-306.

Hooper PL, Turner JR, Conway MJ, et al. 1980. Thyroid uptake of ¹²³I in a normal population. *Arch Intern Med* 140:757-758.

*Horn B, Kabins SA. 1972. Iodide fever. *Am J Med Sci* 264(6):467-471.

Hoshi M, Takada J, Oka T, et al. 1996. A possible explanation for the DS86 discrepancy between the data and calculation in Hiroshima. In: Nagasaki S, Yamashita S, eds. *Nagasaki symposium radiation and human health: Proposal from Nagasaki*. Amsterdam, the Netherlands: Elsevier, 175-191.

9. REFERENCES

- Hoshi M, Yamamoto M, Kawamura H, et al. 1994. Fallout radioactivity in soil and food samples in the Ukraine: Measurements of iodine, plutonium, cesium, and strontium isotopes. *Health Phys* 67(2):187-191.
- Hoskin PJ, Spathis GS, McCready VR, et al. 1985. Low-dose radiation given six-monthly in Graves' disease. *J R Soc Med* 78:893-898.
- *Hou X, Chai C, Qian Q, et al. 1997a. The study of iodine in Chinese total diets. *Sci Total Environ* 193:161-167.
- *Hou X, Chai X, Qian Q, et al. 1997b. Determination of bromine and iodine in normal tissues from Beijing health adults. *Biol Trace Elem Res* 56:225-230.
- Hou X, Dahlgard H, Rietz B, et al. 1999. Determination of chemical species of iodine in seawater by radiochemical neutron activation analysis combined with ion-exchange pre-separation. *Anal Chem* 71:2745-2750.
- Houssay AB, Gamper GH, Arias NH, et al. 1978. Effects of indomethacin upon ^{131}I uptake by thyroid and submaxillary glands in mice. *J Dent Res* 57(1):83-86.
- *Howard JE, Vaswani A, Heotis P. 1997. Thyroid disease among the Rongelap and Utirik population-an update. *Health Phys* 73(1):190-198.
- Howarth DM, Epstein MT, Thomas PA, et al. 1997. Outpatient management of patients with large multinodular goitres treated with fractionated radioiodine. *Eur J Nucl Med* 24(12):1465-1469.
- *Howe JR, Bowlt C. 1991. A rapid method for estimating iodine-125 in water samples using x-ray fluorescence for yield correction. *J radioanal Nucl Chem* 152:347-357.
- *HSDB. 2000. Hazardous Substances Data Bank. National Library of Medicine, National Toxicology Program, Bethesda, MD. July 2000.
- *Huang W, Kukes, GD. 1999. Hashimoto's thyroiditis: An organ-specific autoimmune disease - pathogenesis and recent developments. *Lab. Invest.* 79(10): 1175-1180.
- *Huang T-S, Lu F-J. 1991. Iodide binding by humic acid. *Environ Toxicol Chem* 10:179-184.
- Hughes WL, Weinblatt AC, Prenskey W. 1977. Chromosome damage in Chinese hamster cells produced by ^{125}I -UdR at the site of its incorporation. *Curr Top Radiat Res Q* 12:453-471.
- Hugo AC, Pisarev MA, Juvenal GJ, et al. 1990. Further studies on iodide uptake autoregulation in calf thyroid slices. 40:149-154.
- Hunermann B. 1976. [Iodine-131 treatment of hyperthyroidism.] *Therapiewoche* 26(2):129-133. (German)
- Hurley JR. 1994. Orbitopathy after treatment of Graves' disease. *J Nucl Med* 35(5):918-920.
- Hurley LS. 1980. Trace elements I: Iron, copper, iodine. In: *Developmental nutrition*. Englewood Cliffs, NJ: Prentice-Hall, 183-197.
- Hurrell RF. 1997. Bioavailability of iodine. *Eur J Clin Nutr* 51(Suppl 1):S9-S12.
- *Hutchings PR, Verma S, Phillips JM, et al. 1999. Both CD4(+) T cells and CD8(+) T cells are required for iodine accelerated thyroiditis in NOD mice. *Cell Immunol* 192(2):113-121.

9. REFERENCES

Huysmans DAKC, Buijs WCAM, van de Ven MTP, et al. 1996. Dosimetry and risk estimates of radioiodine therapy for large, multinodular goiters. *J Nucl Med* 37(12):2072-2079.

*Huysmans DAKC, Hermus ARMM, Edelbroek MAL, et al. 1997a. Autoimmune hyperthyroidism occurring late after radioiodine treatment for volume reduction of large multinodular goiters. *Thyroid* 7(4):535-539.

Huysmans D, Hermus A, Edelbroek M, et al. 1997b. Radioiodine for nontoxic multinodular goiter. *Thyroid* 7(2):235-239.

*IAEA. 1962. Whole-body counting. International Atomic Energy Agency. Vienna: IAEA Publication No. STI/PUB/47.

*IAEA. 1970. Directory of whole-body radioactivity monitors. International Atomic Energy Agency. Vienna: IAEA Publication No. STI/PUB/213.

*IAEA. 1972. Assessment of radioactive contamination in man. International Atomic Energy Agency. Vienna: IAEA Publication No. STI/PUB/290.

*IAEA. 1976. Diagnosis and treatment of incorporated radionuclides. International Atomic Energy Agency. Vienna: IAEA Publication No. STI/PUB/411.

*IAEA. 1988. The radiological accident in Goiania. International Atomic Energy Agency. Vienna: IAEA Publication No. STI/PUB/815.

*IAEA. 1985. Assessment of radioactive contamination in man. International Atomic Energy Agency. Vienna: IAEA Publication No. STI/PUB/674.

IAEA. 1989. Measurement of radionuclides in food and the environment. International Atomic Energy Agency. Vienna: IAEA Publication No. STI/DOC/10/295.

*IAEA. 1991. The international Chernobyl project. Technical Report. Assessment of radiological consequences and evaluation of protective measures. International Atomic Energy Agency. Vienna.

*Iancu T, Boyanower Y, Laurian N. 1974. Congenital goiter due to maternal ingestion of iodide. *Am J Dis Child* 128:528-530.

IARC. 1977. IARC monographs on the evaluation of the carcinogenic risk of chemicals to man: Some fumigants, the herbicides 2,5-D and 2,4,5-T, chlorinated dibenzodioxins and miscellaneous industrial chemicals. Lyon, France: International Agency for Research on Cancer.

Ichikawa R. 1978. A comment on the paper "Thyroidal burdens of ¹²⁹I from various dietary sources" by S.A. Book *et al.* *Health Phys* 34:277-278.

*ICRP. 1979. Limits for intakes of radionuclides by workers. ICRP Publication 30, Part 1. International Commission on Radiological Protection. Pergamon Press, Oxford, 88-90.

*ICRP. 1981. Report of the task group on reference man. The International Commission on Radiological Protection. Pergamon Press. ICRP Publ No. 23.

*ICRP. 1988. Radiation dose to patients from radiopharmaceuticals. International Commission on Radiological Protection. Pergamon Press, Oxford. ICRP publ No. 53, 259-277.

*ICRP. 1989. Age-dependent doses to members of the public from intake of radionuclides: Part 1. International Commission on Radiological Protection. Pergamon Press, Oxford. P.45-51.

9. REFERENCES

- *ICRP. 1994a. Dose coefficients for intakes of radionuclides by workers. International Commission on Radiological Protection. Annals of the ICRP. Vol. 24(4). ICRP publication 68.
- *ICRP. 1994b. Human respiratory tract model for radiological protection. International Commission on Radiological Protection. Pergamon Press, Oxford.
- *ICRP. 1995. Age-dependent doses to members of the public from intake of radionuclides: Part 4. Inhalation dose coefficients. International Commission on Radiological Protection. Pergamon Press, Oxford. P.195-232.
- Idee JM, Beaufile H, Bonnemain B. 1994. Iodinated contrast media-induced nephropathy: Pathophysiology, clinical aspects and prevention. *Fundam Clin Pharmacol* 8:193-206.
- *IEA 2000. Key World Energy Statistics from the IEA, 2000 Web Edition (<http://www.iea.org/statist/index.htm>). International Energy Agency, Paris, France.
- *Iff HW, Wilbrandt W. 1963. [The dependency of iodine accumulation in thyroid slices on the ional composition of the incubation medium; influence of heart glycosides.] *Biochim Biophys Acta* 70:711-752. (German)
- *Iiyin LA, Balonov MI, Buldakov LA, et al. 1990. Radiocontamination patterns and possible health consequences of the accidents at the Chernobyl nuclear power station. *J Radiol Prot* 10(13):3-29.
- Ilundain A, Larralde J, Toval M. 1987. Iodide transport in rat small intestine: Dependence on calcium. *J Physiol* 393:19-27.
- Ingbar DH. 1996a. The respiratory system in hypothyroidism. In: Braverman LE, Utiger RD, eds. *Werner and Ingbar's the thyroid: A fundamental and clinical text*. Philadelphia, PA: Lippincott-Raven, 805-810.
- Ingbar DH. 1996b. The respiratory system in thyrotoxicosis. In: Braverman LE, Utiger RD, eds. *Werner and Ingbar's the thyroid: A fundamental and clinical text*. Philadelphia, PA: Lippincott-Raven, 616-627.
- Inman P. 1974. Iododerma. *Br J Dermatol* 91(6):709-711.
- *International Isotopes. 2001. International Isotopes Inc achieves beam in CP-42 MeV accelerator. <http://www.nuclear-medicine.com>. May 22, 2001.
- *IRIS. 2001. Integrated Risk Information System. U.S. Environmental Protection Agency. <http://www.epa.gov/iris/subst/index.htm>.
- Isaacs GH, Rosenberg IN. 1967. Effect of thyrotropin on thyroid clearance of iodide and pertechnetate: Comparative observations at normal and high plasma iodide concentrations. *Endocrinology* 81:981-992.
- Ishikawa M, Izawa G, Omori T, et al. 1985. Application of proton induced x-ray emission to the qualitative and quantitative analysis of iodine in biological samples. *J Radioanal Nucl Chem* 91(1):163-171.
- Ishizuki Y, Hirooka Y, Tanigawa S, et al. 1996. Confirmation of the safety of iodine-overloaded women during lactation. *Nippon Naibunpi Gakkai Zasshi* 72(3):523-532.
- Isozaki O, Emoto N, Tsushima T, et al. 1992. Opposite regulation of deoxyribonucleic acid synthesis and iodide uptake in rat thyroid cells by basic fibroblast growth factor: Correlation with opposite regulation of *c-fos* and thyrotropin receptor gene expression. *Endocrinology* 131(6):2723-2732.

9. REFERENCES

- Itikawa A, Kawada J, Ito Y. 1967. Iodide goiter in the mouse. *Endocrinol Jpn* 14(4):333-341.
- Ito K. 1999. Semi-micro ion chromatography of iodide in seawater. *J Chromatogr* 830:211-217.
- Ito K, Tsuchiya T, Sugino K, et al. 1996. [An evaluation of the incidence of hyperparathyroidism after ¹³¹I treatment for Basedow disease (Part II).] *Kaku Igaku* 33(7):737-742. (Japanese)
- Ivanov VK, Tsyb AF. 1996. Chernobyl radiation risks: Assessments of morbidity, mortality and disability rates according to the data of the National Radiation and Epidemiological Registry, 1995. In: Nagasaki S, Yamashita S, eds. *Nagasaki symposium radiation and human health: Proposal from Nagasaki*. Amsterdam, the Netherlands: Elsevier, 31-42.
- Izembart M, Chavaudra J, Aubert B, et al. 1992. Retrospective evaluation of the dose received by the ovary after radioactive iodine therapy for thyroid cancer. *Eur J Nucl Med* 19:243-247.
- Jackson GL, Flickinger FW, Graham WP, et al. 1979. Thymus accumulation of radioactive iodine. *Pa Med* 82(11):37-38.
- Jackson HJ, Sutherland RM. 1981. Effect of povidone-iodine on neonatal thyroid function [Letter]. *Lancet* 2(8253):992.
- *Jacobson AP, Plato PA, Toeroek D. 1978. Contamination of the home environment by patients treated with iodine-131: Initial results. *Am J Public Health* 68(3):225-230.
- Jacobson JM, Hankins GV, Murray JM, et al. 1981. Self-limited hyperthyroidism following intravaginal iodine administration. *Am J Obstet Gynecol* 140(4):472-473.
- *Jacobson JM, Hankins GV, Young RL, et al. 1984. Changes in thyroid function and serum iodine levels after prepartum use of a povidone-iodine vaginal lubricant. *J Reprod Med* 29(2):98-100.
- *Jafek BW, Small R, Lillian DL. 1974. Congenital radioactive iodine-induced stridor and hypothyroidism. *Arch Otolaryngol* 99:369-371.
- Jagetia GC, Gupta SM, Kumar S, et al. 1982. Response of peripheral blood to ¹³¹I treatment by Swiss albino mice. *Radiobiol Radiother* 23:187-190.
- Jahreis G, Hesse V, Plenert W, et al. 1985. Influence of phytogetic substances with thyreostatic effects in combination with iodine on the thyroid hormones and somatomedin level in pigs. *Exp Clin Endocrinol* 85(2):183-190.
- Jambut-Absil AC, Buxeraud J, Lagorce JF, et al. 1987. Charge transfer complexes of drugs with iodine investigation by UV/visible spectroscopy. *Int J Pharm* 35:129-137.
- James RA 1964. Calculation of radioactive iodine concentrations in milk and human thyroid as a result of nuclear explosions. Lawrence Radiation Laboratory, University of California at Livermore. Livermore, California. UCRL-7716.
- Jay K, Stieglitz L. 1995. Identification and quantification of volatile organic components in emissions of waste incineration plants. *Chemosphere* 30(7):1249-1260.
- Jefferies AL, Coates G, Webber CE, et al. 1984. Measurement of pulmonary clearance of radioaerosol using a portable sodium iodide probe. *J Appl Physiol* 57(6):1908-1912.
- Jelovsek FR, Mattison DR, Chen JJ. 1989. Prediction of risk for human developmental toxicity: How important are animal studies for hazard identification? *Obstet Gynecol* 74:624-636.

9. REFERENCES

- Jendrasiak GL, Estep TN. 1977. The inhibition of iodide uptake in the thyroid gland by the fluorescent dye, ANS. *Life Sci* 21:149-158.
- Jenkins KJ, Hidiroglou M. 1990. Effects of elevated iodine in milk replacer on calf performance. *J Dairy Sci* 73:804-807.
- Jensen RH, Reynolds JC, Robbins J, et al. 1997. Glycophorin A as a biological dosimeter for radiation dose to the bone marrow from iodine-131. *Radiat Res* 147:747-752.
- *Jialal I, Pillay NL, Asmal AC. 1980. Radio-iodine-induced hypoparathyroidism. *S Afr Med J* 58:939-940.
- *Jirousek L, Pritchard ET. 1971. On the chemical iodination of tyrosine with protein sulfenyl iodide and sulfenyl periodide derivatives: The behavior of thiol protein-iodine systems. *Biochemica Biophysica Acta* 243:230-238.
- Jirousek L, Soodak M. 1974. Studies of positive iodine compounds as models of the thyroidal "active iodine": Reaction of N-iodosuccinimide and of N-iodophthalimide with thiocarbamide goitrogens. *J Pharmacol Exp Ther* 191(2):341-348.
- *Johanson CE. 1980. Permeability and vascularity of the developing brain: Cerebellum vs cerebral cortex. *Brain Res* 190:3-16.
- Johansson H, Nylander G. 1968. Effect of iodine and thyroxine on the thyroid in thiouracil-treated rats. *Acta Soc Med Ups* 74:151-160.
- *John W, Kaifer R, Rahn K, et al. 1973. Trace element concentrations in aerosols from the San Francisco bay area. *Atmos Environ* 7:107-118.
- Johnson CE, Cohen IA. 1988. Theophylline toxicity after iodine 131 treatment for hyperthyroidism. *Clin Pharm* 7:620-622.
- Johnson JK. 1993. Outcome of treating thyrotoxic patients with a standard dose of radioactive iodine. *Scott Med J* 38:142-144.
- Johnson JR. 1978. Summary of bioassay and thyroid monitoring results following an accidental exposure to ¹²⁵I. *Health Phys* 34:106-107.
- Johnson JR. 1982. Fetal thyroid dose from intakes of radioiodine by the mother. *Health Phys* 43(4):573-582.
- Johnson JR. 1992. Fetal thyroid dose from intakes of radioiodine by the mother. *Health Phys* 43(4):573-782.
- Johnson JR, Lamothe ES. 1987. Dose to the basal layer of the skin from ¹²⁵I skin contamination. *Radiat Prot Dosim* 20(4):253-256.
- Johnson TM, Rapini RP. 1988. The Wolff-Chaikoff effect: Hypothyroidism due to potassium iodide [Letter]. *Arch Dermatol* 124:1184-1185.
- Jonadet M, Chopineau J, Bastide P. 1982. [Optotoxic effects of sodium iodate on several enzymatic activities of the retina (glycolysis, Krebs cycle, pentose cycle.] *Ann Pharm Fr* 40(3):281-289. (French)
- Jonckheer MH, Velkeniers B, Vanhaelst L, et al. 1992. Further characterization of iodide-induced hyperthyroidism based on the direct measurement of intrathyroidal iodine stores. *Nucl Med Commun* 13:114-118.

9. REFERENCES

- Jones AR, Edwards K. 1973. Alkylating esters VII. The metabolism of iso-propyl methanesulphonate and iso-propyl iodide in the rat. *Experientia* 29(5):538-539.
- *Jones RE, Aulerich RJ, Ringer RK. 1982. Feeding supplemental iodine to mink: Reproductive and histopathologic effects. *J Toxicol Environ Health* 10:459-471.
- *Jones SD, Spencer CP, Truesdale VW. 1982. Determination of total iodine and iodate-iodine in natural freshwater. *Analyst* 107:1417-1424.
- *Jönsson H, Mattsson S. 1998. Thyroid burdens of ¹²⁵I in hospital laboratory workers during a 20-y period. *Health Phys* 75(5):475-478.
- Jorgensen JV, Brandrup F, Schroll M. 1973. Possible synergism between iodine and lithium carbonate. *JAMA* 223(2):192-193.
- Joseph K, Mahlstedt J, Welcke U. 1980. [Early recognition of autonomous thyroid tissue by a combination of quantitative thyroid pertechnetate scintigraphy with the free T₄ equivalent.] *Nuklearmedizin* 19(2):54-63. (German)
- Joshi P. 1989. A complication of povidone-iodine. *Anaesthesia* 44(8):692.
- Jost DT, Gaggeler HW, Baltensperger U, et al. 1986. Chernobyl fallout in size-fractionated aerosol [Letter]. *Nature* 324(6092):22-23.
- Joyce WT, Cowan RJ. 1995. A potential false-positive posttherapy radioiodine scan secondary to I-131 excretion in perspiration. *Clin Nucl Med* 20:368-369.
- *Jubiz W, Carlile S, Lagerquist LD. 1977. Serum thyrotropin and thyroid hormone levels in humans receiving chronic potassium iodide. *J Clin Endocrinol Metab* 44:379-382.
- Juhasz F, Stenszky V, Bartha I, et al. 1983. A complex clinical and genetic analysis of patients with medullary thyroid carcinoma. *Acta Endocrinol Suppl* 252:16-17.
- Juvenal GJ, Pregliasco LB, Krawiec L, et al. 1997. Long-term effect of norepinephrine on iodide uptake in FRTL-5 cells. *Thyroid* 7(5):795-800.
- *Kada T. 1970. Radio-sensitization with iodine compounds: II. Studies on mutant strains of *escherichia coli* K12 resistant to radiation-induced toxic products from iodoacetic acid, potassium iodide or potassium iodate. *Int J Radiat Biol* 17(5):419-430.
- *Kada T, Noguti T, Namiki M. 1970. Radio-sensitization with iodine compounds: I. Examination of damage in deoxyribonucleic acid with *bacillus subtilis* transformation system by irradiation in the presence of potassium iodide. *Int J Radiat Biol* 17(5):407-418.
- Kader A, Ahmad S, El-Gendy AE, et al. 1994. Spectrophotometric studies on molecular interactions I. Complexation of iodine with polyvinylpyrrolidone polymer and with the monomer n-methyl-2-pyrrolidone. *Bull Fac Pharm (Cairo Univ)* 32(1):17-23.
- Kagan RJ, Miller RW, Wagner WM. 1976. Radioiodine breathing zone monitor efficiency as a function of radioiodine concentration and sampling rate. *Health Phys* 31(6):555-556.
- *Kahaly G, Dienes HP, Beyer J, et al. 1997. Randomized, double blind, placebo-controlled trial of low dose iodide in endemic goiter. *J Clin Endocrinol Metab* 82(12):4049-4053.
- *Kahaly GJ, Dienes HP, Beyer J, et al. 1998. Iodide induced thyroid autoimmunity in patients with endemic goitre: A randomised, double-blind, placebo-controlled trial. *Eur J Endocrinol* 139:290-297.

9. REFERENCES

- Kalk WJ, Durbach D, Kantor S, et al. 1980. Very low doses of radio-iodine for hyperthyroidism: Failure to prevent a high incidence of early hypothyroidism. *S Afr Med J* 57:479-482.
- Kanda T, Ghidoni JJ. 1970. Light and electron microscopic observations on iodide-induced sialoadenitis of hamster submaxillary glands. *Laryngoscope* 80(3):455-466.
- Kang Z, Zhou Q, Liu S. 1995. [The early development of hypothyroidism after ^{131}I treatment for hyperthyroid Graves' disease.] *Zhonghua Heyixue Zazhi* 15(1):26-28. (Chinese)
- Kanno J, Onodera H, Furuta K, et al. 1992. Tumor-promoting effects of both iodine deficiency and iodine excess in the rat thyroid. *Toxicol Pathol* 20(2):226-235.
- Kapitola J, Kuechel O, Schreiberova O, et al. 1968. Decreased thyroid radioiodine uptake after diazoxide in rats. *Experientia* 24(1):50-51.
- Kapitola J, Schullerova M, Schreiberova O. 1970. Blood flow and radioiodine uptake in the thyroid gland of rats after administration and discontinuation of methylthiouracil. *Acta Endocrinol* 65:435-441.
- Kaplan MM, Garnick MB, Gelber R, et al. 1983. Risk factors for thyroid abnormalities after neck irradiation for childhood cancer. *Am J Med* 74:272-280.
- Kaplan MM, Meier DA, Dworkin HJ. 1998. Treatment of hyperthyroidism with radioactive iodine. *Endocrinol Metab Clin North Am* 27(1):205-223.
- Kapuscinski W, Bacin F, Kantelip B, et al. 1979. [Experimental retinopathy induced by sodium iodate: Comparison with human retinitis pigmentosa.] *Bull Soc Ophthalmol Fr* 79(3):231-238. (French)
- Kargacin B, Kostial K. 1985. Reduction of ^{85}Sr , ^{137}Cs , ^{131}I and ^{141}Ce retention in rats by simultaneous oral administration of calcium alginate, ferrihexacyanoferrate(II), KI and Zn-DTPA. *Health Phys* 49:858-864.
- Karlan MS, Pollock WF, Snyder WH. 1964. Carcinoma of the thyroid following treatment of hyperthyroidism with radioactive iodine. *Calif Med* 101(3):196-199.
- Kasatkina EP, Shilin DE, Matkovskaya AN, et al. 1995. [Radiation-induced pathomorphism of endemic goiter in children and adolescents in a focus of iodine deficiency (initial manifestations of remote effects of the Chernobyl accident).] *Probl Endokrinol (Mosk)* 41(3):17-23. (Russian)
- Kassis AI, Fayad F, Kinsey BM, et al. 1987a. Radiotoxicity of ^{125}I in mammalian cells. *Radiat Res* 111:305-318.
- Kassis AI, Sastry KSR, Adelstein SJ. 1987b. Kinetics of uptake, retention, and radiotoxicity of ^{125}I UdR in mammalian cells: Implications of localized energy deposition by auger processes. *Radiat Res* 109:78-89.
- Katagiri K, Shimizue T, Akatsu Y, et al. 1997. Study on the behavior of ^{129}I in the terrestrial environment. *J Radioanal Nucl Chem* 226(1-2):23-27.
- *Katayama Y, Widdicombe JH. 1991. Halide transport in *xenopus* oocytes. *J Physiol* 443:587-599.
- Kato GT (1981): A comparison study between I-123 and I-131 in thyroid uptakes in adults. Master of Science in Medical Physics Thesis, University of California, Los Angeles. 38 p.
- Kaul A, Roedler HD. 1980. Radioiodine: Biokinetics, mean dose and dose distribution. *Radiat Environ Biophys* 18:185-195.
- *Kay C, Abrahams S, McClain P. 1966. The weight of normal thyroid glands in children. *Arch Pathol* 82:349-352.

9. REFERENCES

Kay TWH, Heyma P, Harrison LC, et al. 1987. Graves disease induced by radioactive iodine. *Ann Intern Med* 107(6):857-858.

*Kearns JE, Philipsborn HF. 1962. Values for thyroid uptake of I^{131} and protein-bound iodine in "normal" individuals from birth to twenty years. *Q Bull Northwest Univ Med Sch* 36:47-50.

Keating FR, Albert A. 1949. The metabolism of iodine in man as disclosed with the use of radioiodine. *Recent Prog Horm Res* IV:429-481.

Keith RL, McGuinness SJ, Gandolfi AJ, et al. 1995. Interaction of metals during their uptake and accumulation in rabbit renal cortical slices. *Environ Health Perspect Suppl* 103(1):77-80.

Keldsen N, Mortensen BT, Hansen HS. 1990. Hematological effects from radioiodine treatment of thyroid carcinoma. *Acta Oncol* 29:1035-1039.

Kellen JA. 1973. Induction of rat mammary tumours in altered iodine metabolism. *Oncology* 28:269-273.

Kelly GN. 1977. Global circulation of iodine 129. In: ed. Iodine 129: Proceedings of an NEA specialist meeting. Paris, France: Organisation for Economic Co-Operation and Development, 40-42.

Kemp WN. 1939. Iodine deficiency in relation to the stillbirth problem. *Can Med Assoc J* 41:356-361.

Kendall-Taylor P, Keir MJ, Ross WM. 1984. Ablative radioiodine therapy for hyperthyroidism: Long term follow up study. *Br Med J* 289:361-363.

Kennedy JS, Thomson JA. 1974. The changes in the thyroid gland after irradiation with ^{131}I or partial thyroidectomy for thyrotoxicosis. *J Pathol* 112:65-81.

Kennish MJ. 1998. Trace metal-sediment dynamics in estuaries: Pollution assessment. *Rev Environ Contam Toxicol* 155:69-110.

*Kerber RA, Till JE, Simon SL, et al. 1993. A cohort study of thyroid disease in relation to fallout from nuclear weapons testing. *JAMA* 270:2076-2082.

*Kereiakes JG, Wellman HN, Simmons G, et al. 1972. Radiopharmaceutical dosimetry in pediatrics. *Semin Nucl Med* 2(4):316-327.

*Kerl W, Becker JS, Dietze H-J, et al. 1996. Determination of iodine using a special sample introduction system coupled to a double-focusing sector field inductively coupled plasma mass spectrometer. *J Anal Atom Spectrom* 11:723-726.

*Kessler FK, Laskin DL, Borzelleca JF, et al. 1980. Assessment of somatogenotoxicity of povidone-iodine using two in vitro assays. *J Environ Pathol Toxicol* 4(2-3):327-335.

*Khan F, Einbinder JM, Seriff NS. 1973. Suppurative ulcerating iododerma-a rare manifestation of inorganic iodide hypersensitivity. *N Engl J Med* 289:1018-1020.

*Khan LK, Ruowel LI, Gootnick D, et al. 1998. Thyroid abnormalities related to iodine excess from water purification units. *Lancet* 352:1519.

Khanna CM, Jain SK, Walia RP. 1994. Thyrotoxicosis-treatment by ^{131}I therapy and early prediction of hypothyroidism following this therapy. *J Assoc Physicians India* 42(1):36-38.

*Kidd PS, Trowbridge FL, Goldsby JB, et al. 1974. Sources of dietary iodine. *Journal of the American Dietary Association* 65:420-422.

9. REFERENCES

- *Kim WS, McGlothlin JD, Kupel RE. 1981. Sampling and analysis of iodine in the industrial atmosphere. *Am Ind Hyg Assoc J* 42(3):187-190.
- *Kimura S, Kotani T, McBride OW et al. 1987. Human thyroid peroxidase: Complete cDNA and protein sequence, chromosome mapping and identification of two alternately spliced mRNAs. *Proc Natl Acad Sci USA* 84:5555-5559.
- *Kincaid MC, Green WR, Hoover RE, et al. 1981. Iododerma of the conjunctiva and skin. *Ophthalmology* 88:1216-1220.
- *Kint A, Van Herpe L. 1977. Iododerma. *Dermatologica* 155(3):171-173.
- Kinuya S, Hwang E-H, Ikeda E, et al. 1997. Mallory-Weiss syndrome caused by iodine-131 therapy for metastatic thyroid carcinoma. *J Nucl Med* 38(11):1831.
- *Kirchner G. 1994. Transport of iodine and cesium via the grass-cow-milk pathway after the Chernobyl accident. *Health Phys* 66(6):653-665.
- *Kiviniitty K, Nasman P, Leppaluoto J. 1984. Accumulation of ¹²⁵I in the thyroid glands of laboratory workers. *Health Phys* 46(1):234-236.
- *Klebanoff SJ, Green WL. 1973. Degradation of thyroid hormones by phagocytosing human leukocytes. *J Clin Invest* 52:60-72.
- Kleiman de Pisarev DL, Pisarev MA, Juvenal GJ. 1978. Action of KI and several iodocompounds on [³H]uridine incorporation into thyroid RNA. *Acta Endocrinol* 89:316-322.
- Klein E. 1972. [Thyroid hormones following iodine isotope therapy.] *Dtsch Med Wochenschr* 97:42. (German)
- Klein I, Levey GS. 1983. Iodide excess and thyroid function. *Ann Intern Med* 98(3):406-407.
- Klein I, Levey GS. 1996. The cardiovascular system in thyrotoxicosis. In: Braverman LE, Utiger RD, eds. *Werner and Ingbar's the thyroid: A fundamental and clinical text*. Philadelphia, PA: Lippincott-Raven, 607-615.
- Klein I, Ojamaa K. 1996. The cardiovascular system in hypothyroidism. In: Braverman LE, Utiger RD, eds. *Werner and Ingbar's the thyroid: A fundamental and clinical text*. Philadelphia, PA: Lippincott-Raven, 799-804.
- Klein RZ, Mitchell ML. 1996. Hypothyroidism in infants and children. In: Braverman LE, Utiger RD, eds. *Werner and Ingbar's the thyroid: A fundamental and clinical text*. Philadelphia, PA: Lippincott-Raven, 984-988.
- Klonecke A, Peterson MM, McDougall IR. 1990. Thyrotoxicosis with low thyroidal uptake of radioiodine. *Semin Nucl Med* XX(4):364-366.
- Ko YI, Kim SS, Han SK. 1995. Transdermal permeation-enhancing activities of some inorganic anions. *Arch Pharmacol Res* 18(4):231-236.
- Kobberling J, Hintze G, Becker HD. 1985. Iodine-induced thyrotoxicosis- A case for subtotal thyroidectomy in severely ill patients. *Klin Wochenschr* 63:1-7.
- Kocher DC. 1991. A validation test of a model for long-term retention of ¹²⁹I in surface soils. *Health Phys* 60(4):523-531.

9. REFERENCES

- *Kogai T, Endo T, Saito T, et al. 1997. Regulation by thyroid-stimulating hormone of sodium/iodide symporter gene expression and protein levels in FRTL-5 cells. *Endocrinology* 138(6):2227-2232.
- *Koh T, Ono M, Makino I. 1988. Spectrophotometric determination of iodide at the 10^{-6} mol l^{-1} level by solvent extraction with methylene blue. *Analyst* 113:945-948.
- Kohan SL, Guillen CE, Pardes EM, et al. 1992. Effects of keotconazole on the iodide uptake by FRTL-5 cells. *Acta Endocrinol* 127:449-453.
- *Kohn LA. 1975. A look at iodine-induced hyperthyroidism: Recognition. *Bull N Y Acad Med* 51(8):959-966.
- *Kohn LA. 1976. The midwestern American "epidemic" of iodine-induced hyperthyroidism in the 1920s. *Bull N Y Acad Med* 52(7):770-781.
- Kohrle J. 1994. Thyroid hormone deiodination in target tissues-a regulatory role for the trace element selenium. *Exp Clin Endocrinol* 102:63-89.
- *Kolonel LN, Hankin JH, Wilkens LR, et al. 1990. An epidemiologic study of thyroid cancer in Hawaii. *Cancer Causes Control* 1:223-234.
- *Komori M, Nishio K, Kitada M, et al. 1990. Fetus-specific expression of a form of cytochrome P-450 in human livers. *Biochemistry* 29:4430-4433.
- Konermann G. 1992. Biokinetics of radioiodine (^{125}I) during pre and post-natal development and the interference with the induction of developmental effects in the mouse brain. *Radiat Prot Dosim* 41:157-162.
- *Konno N, Makita H, Yuri K, et al. 1994. Association between dietary iodine intake and prevalence of subclinical hypothyroidism in the coastal regions of Japan. *J Clin Endocrinol Metab* 78(2):393-397.
- *Konno N, Taguchi H, Miura K, et al. 1993a. Serum thyrotropin concentration in apparently healthy adults, in relation to urinary iodide concentration. *Clin Chem* 39(1):174-175.
- *Konno N, Yuri K, Miura K, et al. 1993b. Clinical evaluation of the iodide/creatinine ratio of casual urine samples as an index of daily iodine excretion in a population study. *Endocrine Journal* 40(1):163-169.
- Konoplya EF, Fil'chenkov GN, Popov EG, et al. 1992. [Effect of iodine-131 on sex and thyroid hormone binding to blood plasma proteins in children with functional lesions of the thyroid gland as a result of Chernobyl disaster.] *Radiobiologiya* 32(4):488-492. (Russian)
- Konukoglu D, Hatemi HH, Arikan S, et al. 1998. Radioiodine treatment and oxidative stress in thyroidectomised patients for differentiated thyroid cancers. *Pharmacol Res* 38(4):311-315.
- Koong S-S, Reynolds JC, Movius EG, et al. 1999. Lithium as a potential adjuvant to ^{131}I therapy of metastatic, well differentiated thyroid carcinoma. *J Clin Endocrinol Metab* 84(3):912-916.
- Korolev GK. 1970. [Metabolism of iodine-131 in relation to the path of entry and the toxic action following entry into the respiratory system.] In: *Raspredel kinet obmena biol diestvie radioaktiv izotop ioda*, 36-45. (Russian)
- Korsager S, Kristensen HPO. 1979. Iodine-induced hypothyroidism and its effect on the severity of asthma. *Acta Med Scand* 205:115-117.
- Kostial K, Kargacin B, Rabar I, et al. 1981. Simultaneous reduction of radioactive strontium, caesium and iodine retention by single treatment in rats. *Sci Total Environ* 22:1-10.

9. REFERENCES

- Kostial K, Vnucec M, Tominac C, et al. 1980. A method for a simultaneous decrease of strontium, caesium and iodine retention after oral exposure in rats. *Int J Radiat Biol* 37(3):347-350.
- *Kosugi S, Inoue S, Matsuda A, et al. 1998. Novel, missense and loss-of-function mutations in the sodium/iodide symporter gene causing iodide transport defect in three Japanese patients. *J Clin Endocrinol Metab* 83(9):3373-3376.
- Kotajima A, Miyamoto Y, Tsuruo M, et al. 1995. Effects of activin A on deoxyribonucleic acid synthesis, iodine metabolism, and cyclic adenosine monophosphate accumulation in porcine thyroid cells. *Endocrinology* 136(3):1214-1218.
- *Koutras DA. 1996. Control of efficiency and results, and adverse effects of excess iodine administration on thyroid function. *Ann Endocrinol (Paris)* 57:463-469.
- Koyanagi T, Hirano S, Matsuba M. 1985. The transfer of radioiodine in different chemical forms through food chain. *J Radiat Res* 26(1):83.
- Kraiem Z, Sadeh O, Blithe DL, et al. 1994. Human chorionic gonadotropin stimulates thyroid hormone secretion, iodide uptake, organification, and adenosine 3',5'-monophosphate formation in cultured human thyrocytes. *J Clin Endocrinol Metab* 79(2):595-599.
- Kraiem Z, Sadeh O, Yosef M. 1991. Iodide uptake and organification, tri-iodothyronine secretion, cyclic AMP accumulation and cell proliferation in an optimized system of human thyroid follicles cultured in collagen gel suspended in serum-free medium. *J Endocrinol* 131:499-506.
- Krari N, Berre S, Allain P. 1992. Effects of thyroparathyroidectomy on the distribution of bromine and iodine in rat tissues. *Biol Trace Elem Res* 32:275-279.
- Krawiec L, Ryder E, Campos G. 1981. Excessive ingestions of iodide by the rat during pregnancy and lactation. Effects on ribonucleic acid transcription in the pups brain. *Acta Physiol Latinoam* 31:241-247.
- Kreps EM, Kreps SM, Kreps SI. 1973. Treatment of hyperthyroidism with sodium iodide I 131: Carcinoma of the thyroid after 20 years. *JAMA* 226(7):774-775.
- Krisch RE, Sauri CJ. 1977. DNA breakage, repair, and lethality accompanying ¹²⁵I decay in microorganisms. *Curr Top Radiat Res Q* 12:355-368.
- *Krishnan K, Andersen ME. 1994. Physiologically based pharmacokinetic modeling in toxicology. In: Hayes AW, ed. *Principles and methods of toxicology*. 3rd ed. New York, NY: Raven Press, Ltd., 149-188.
- *Krishnan K, Andersen ME, Clewell HJ III, et al. 1994. Physiologically based pharmacokinetic modeling of chemical mixtures. In: Yang RSH, ed. *Toxicology of chemical mixtures: Case studies, mechanisms, and novel approaches*. San Diego, CA: Academic Press, 399-437.
- Krishnan U, Que Hee SS. 1992. Ear wax: A new biological monitoring medium for metals. *Bull Environ Contam Toxicol* 48:481-486.
- Krouse TB, Eskin BA, Mobini J. 1979. Age-related changes resembling fibrocystic disease in iodine-blocked rat breasts. *Arch Pathol Lab Med* 103:631-634.
- *Krzysiak JA, Chomicki OA, Czerminska M, et al. 1979. Airborne radioiodine contamination caused by ¹³¹I treatment. *Nuklearmedizin* 18(5):246-251.
- Krzysiak JW. 1978. A laboratory for investigating and monitoring the contamination of air with radioactive iodine. *Postepy Fiz Med* 13(1):53-65.

9. REFERENCES

- Krzesniak JW, Porstendorfer J. 1978. Diffusion coefficients of airborne radioactive iodine and methyl iodide. *Health Phys* 35:417-421.
- Krzesniak JW, Chomiccki OA, Krajewski P, et al. 1983. Radiation hazards from inhaled airborne radioiodine in a nuclear medicine unit. In: *Nuclear medicine and biology advances: Proceedings of the third World Congress of Nuclear Medicine and Biology, August 29 to September 2, 1982, Paris, France.* Oxford, England: Pergamon Press, 2985-2988.
- Krzesniak JW, Krajewski P, Emrich D, et al. 1986. Personnel inhalation hazard during "In-Vitro" and "In-Vivo" work with ^{125}I and ^{131}I [Abstract]. *Nuklearmedizin* 25(4):A74.
- Krzesniak JW, Schuernbrand P, Porstenduerfer J, et al. 1984. Levels of airborne contamination while handling ^{125}I and ^{131}I and $^{99\text{m}}\text{Tc}$ unsealed sources in medical diagnostic procedures. In: *Radiat. Risk. Prot., Int. Congr., 6th.,* 833-836.
- Kuleff I, Zotshev S, Stefanov G. 1986. Determination of the ^{129}I content of the primary coolant nuclear power reactors. *J Radioanal Nucl Chem* 97(1):73-79.
- Kumamoto T, Toyooka K, Nishida M, et al. 1990. Effect of 2,4-dihydro-3H-1,2,4-triazole-3-thiones and thiosemicarbazones on iodide uptake by the mouse thyroid: The relationship between their structure and anti-thyroid activity. *Chem Pharm Bull* 38(9):2595-2596.
- Kung AWC, Yau CC, Cheng A. 1994. The incidence of ophthalmopathy after radioiodine therapy for Graves' disease: Prognostic factors and the role of methimazole. *J Clin Endocrinol Metab* 79:542-546.
- Kung AW, Yau C-C, Cheng AC. 1995. The action of methimazole and L-thyroxine in radioiodine therapy: A prospective study on the incidence of hypothyroidism. *Thyroid* 5(1):7-12.
- Kunze J, Kaiser HJ, Petres J. 1983. [Relevance of a iodine-allergy to commercialized povidone-iodine-preparations.] *Z Hautkr* 58(4):255-261. (German)
- *Kurtz SC, Aber RC. 1982. Potassium iodide as a cause of prolonged fever. *Arch Intern Med* 142:1543-1544.
- *Kwok CS, Hilditch TE. 1982. Airborne iodine-125 arising from surface contamination. *Phys Med Biol* 27(1):149-151.
- Labbe E, Peyroux T. 1984. Mechanisms of adverse reactions to iodinated contrast material. *Radiat Med* 2(2):93-100.
- Labmann M, Hanscheid H, Schelper L-F, et al. 1998. [Measurement of incorporation in family members of patients with benign thyroid disease after radioiodine therapy.] *Nuklearmedizin* 37:120-123. (German)
- Lachapelle JM. 1984. Occupational allergic contact dermatitis to povidone-iodine. *Contact Dermatitis* 11(3):189-190.
- Ladenson PW. 1996a. Diagnosis of hypothyroidism. In: Braverman LE, Utiger RD, eds. *Werner and Ingbar's the thyroid: A fundamental and clinical text.* Philadelphia, PA: Lippincott-Raven, 878-882.
- Ladenson PW. 1996b. Diagnosis of thyrotoxicosis. In: Braverman LE, Utiger RD, eds. *Werner and Ingbar's the thyroid: A fundamental and clinical text.* Philadelphia, PA: Lippincott-Raven, 708-712.
- LaFranchi S, Mandel SH. 1996. Graves' disease in the neonatal period and childhood. In: Braverman LE, Utiger RD, eds. *Werner and Ingbar's the thyroid: A fundamental and clinical text.* Philadelphia, PA: Lippincott-Raven, 1000-1008.

9. REFERENCES

- Laing RW, Saunders MI. 1992. A case of lung carcinoma induced by radioactive iodine given for disseminated thyroid carcinoma. *Clin Oncol* 4:394-395.
- *l'Allemand D, Gruters A, Beyers P, et al. 1987. Iodine in contrast agents and skin disinfectants is the major cause for hypothyroidism in premature infants during intensive care. *Horm Res* 28:42-49.
- *l'Allemand D, Gruters A, Heidemann P, et al. 1983. Iodine-induced alterations of thyroid function in newborn infants after prenatal and perinatal exposure to povidone iodine. *J Pediatr* 102(6):935-938.
- Lamberg-Allardt C, Valtonen E, Polojarvi M, et al. 1991. Characterization of 1,25-dihydroxy-vitamin D₃ receptor in FRTL-5 cells. Evidence for an inhibitory effect of 1,25-dihydroxy-vitamin D₃ on thyrotropin-induced iodide uptake. *Mol Cell Endocrinol* 81:25-31.
- *Lambert A, Lowe AG. 1978. Chloride/bicarbonate exchange in human erythrocytes. *J Physiol* 275:51-63.
- Lambert JP. 1981. Report of a minor ¹²⁵I exposure in a research laboratory. *Health Phys* 40:746-748.
- *Landon S, Smith PG, Staniek SP, et al. 1980. Advantages of using thin sodium iodide detectors for thyroid monitoring of personnel working with ¹²⁵I. *Clin Chem* 26(1):18-21.
- Lang JCT, Lees JFH, Alexander WD, et al. 1983a. Effect of variations in acute and chronic iodine intake on the accumulation and metabolism of [³⁵S]methimazole by the rat thyroid gland: Differences from [³⁵S]propylthiouracil. *Biochem Pharmacol* 32(2):241-247.
- Lang JCT, Lees JFH, Alexander WD, et al. 1983b. Effect of variations in acute and chronic iodine uptake on the accumulation and metabolism of [³⁴S]propylthiouracil by the rat thyroid gland. *Biochem Pharmacol* 32(2):233-240.
- *Langer P, Moravec R, Ohradka B, Foldes O. 1988. Iodothyronines in human bile. *Endocrinol Exp* 22:35-39.
- *Larsen PR, Berry MJ. 1994. Type I iodothyronine deiodinase: Unexpected complexities in a simple deiodination reaction. *Thyroid* 4(3):357-362.
- Larsen PR, Wolff J. 1967. Iodide transport: Inhibition by agents reacting at the membrane. *Science* 155:335-336.
- *Larsen PR, Davies TF, Hay ID. 1998. The thyroid gland. In: Wilson JD, Foster DW, Kronenberg HM, et al., eds. *Williams textbook of endocrinology*. Philadelphia, PA: W.B. Saunders Company, 390-515.
- *Lauber K. 1975. Iodine determination in biological material. Kinetic measurement of the catalytic activity of iodide. *Anal Chem* 47:769-771.
- Laurberg P, Bulow Pedersen I, Pedersen KM, et al. 1999. Low incidence of rate of overt hypothyroidism compared with hyperthyroidism in an area with moderately low iodine intake. *Thyroid* 9(1):33-38.
- *Laurberg P, Pedersen KM, Hreidarsson A, et al. 1998. Iodine intake and the pattern of thyroid disorders: A comparative epidemiological study of thyroid abnormalities in the elderly in Iceland and in Jutland, Denmark. *J Clin Endocrinol Metab* 83(3):765-769.
- Laurent E, Mockel J, Takazawa K, et al. 1989. Stimulation of generation of inositol phosphates by carbamoylcholine and its inhibition by phorbol esters and iodide in dog thyroid cells. *Biochem J* 263:795-801.

9. REFERENCES

- Laurenti L, Salutari P, Sica S, et al. 1998. Acute myeloid leukemia after iodine-131 treatment for thyroid disorders. *Ann Hematol* 76:271-272.
- Laurie AJ, Lyon SG, Lasser EC. 1992. Contrast material iodides: Potential effects on radioactive iodine thyroid uptake. *J Nucl Med* 33:237-238.
- *Lauterbach A, Ober G. 1995. Iodine and iodine compounds. In: Kirk-Othmer encyclopedia of chemical technology. 4th ed. Vol. 14. New York, NY: John Wiley and Sons, 709-737.
- Lavelle KF, Doedens DJ, Kleit SA, et al. 1975. Toxicity of sodium iodide in the rabbit: Effects on hydrogen ion homeostasis, hepatic and renal functions. *Toxicol Appl Pharmacol* 33:52-61.
- Laverock MJ, Stephenson M, Macdonald CR. 1995. Toxicity of iodine, iodide, and iodate to *daphnia magna* and rainbow trout (*oncorhynchus mykiss*). *Arch Environ Contam Toxicol* 29:344-350.
- Lavu S, Reddy PP, Reddi OS. 1985a. Chromosomal abnormalities induced by iodine-125 in mouse germ cells. *Int J Radiat Biol* 48(4):603-607.
- Lavu S, Reddy PP, Reddi OS. 1985b. Iodine-125 induced micronuclei and sperm head abnormalities in mice. *Int J Radiat Biol* 47(3):249-253.
- *Law LW. 1938. The effects of chemicals on the lethal mutation rate in *drosophila melanogaster*. *Proc Natl Acad Sci U S A* 24:546-550.
- *Lawes SC. 1992. ¹²³I excretion in breast milk - additional data. *Nucl Med Commun* 13:570-572.
- *Lawrence JC. 1998. The use of iodine as an antiseptic agent. *J Wound Care* 7(8):421-425.
- Lawrence JE, Lamm SH, Braverman LE. 1999. The use of perchlorate for the prevention of thyrotoxicosis in patients given iodine rich contrast agents. *J Endocrinol Invest* 22:405-407.
- Lazarus JH. 1994. Thyroxine excess and pregnancy. *Acta Med Austriaca* 21:53-56.
- Lazarus JH. 1996. Silent thyroiditis and subacute thyroiditis. In: Braverman LE, Utiger RD, eds. Werner and Ingbar's the thyroid: A fundamental and clinical text. Philadelphia, PA: Lippincott-Raven, 577-591.
- Lazarus JH. 1999. Thyroid hormone and intellectual development: A clinician's view. *Thyroid* 9(7):659-660.
- Lazarus JH, Muston HL. 1978. The effect of lithium on the iodide concentrating mechanism in mouse salivary gland. *Acta Pharmacol Toxicol (Copenh)* 43:55-58.
- Lecos C. 1983. Tracking trace minerals. *FDA Consum* 17:16-21.
- Lee JY, Sawada S, Satow Y. 1990. Toxicity of iodine to the rat embryos. *J Radiat Res* 31(1):79.
- Lee JY, Shoji S, Satow Y. 1989. Developmental toxicity of potassium iodide in rats. *Teratology* 40(6):676-677.
- Lee K, Bradley R, Dwyer J, et al. 1999. Too much versus too little: The implications of current iodine intake in the United States. *Nutr Rev* 57(6):177-181.
- Lee TC, Habert JC, Dejter SW, et al. 1985. Vocal cord paralysis following I-131 ablation of a postthyroidectomy remnant. *J Nucl Med* 26:49-50.

9. REFERENCES

- Lee W-NP, Mpanias PD, Wimmer RJ, et al. 1978. Use of I-123 in early radioiodide uptake and its suppression in children and adolescents with hyperthyroidism. *J Nucl Med* 19:985-993.
- Lee W, Chiacchierini RP, Shleien B, et al. 1981. Dose responses in thyroid tumor inductions from iodine-131 and localized thyroid and pituitary irradiations in rats. *Radiat Res* 87(2):452.
- Lee W, Chiacchierini RP, Shleien B, et al. 1982. Thyroid tumors following ¹³¹I or localized X irradiation to the thyroid and pituitary glands in rats. *Radiat Res* 92:307-319.
- Lee W, Shleien B, Telles NC, et al. 1979. An accurate method of ¹³¹I dosimetry in the rat thyroid. *Radiat Res* 79:55-62.
- *Leeder JS, Kearns GL. 1997. Pharmacogenetics in pediatrics: Implications for practice. *Pediatr Clin North Am* 44(1):55-77.
- *Leger AF, Massin JP, Laurent MF, et al. 1984. Iodine-induced thyrotoxicosis: Analysis of eighty-five consecutive cases. *Eur J Clin Invest* 14:449-455.
- *Leger FA, Doumith R, Courpotin C, et al. 1987. Complete iodide trapping defect in two cases with congenital hypothyroidism: Adaptation of thyroid to huge iodide supplementation. *Eur J Clin Invest* 17:249-255.
- Le Guen B, Malarbet JL, Roy M, et al. 1998. Methodology for ¹²⁹I dose calculations, in the case of potential exposure from nuclear waste in France. *Radiat Prot Dosim* 79(1-4):211-214.
- *Lehmann L, Zitzelsberger H, Kellerer AM. 1996. Chromosome translocations in thyroid tissues from Belarussian children exposed to radioiodine from the Chernobyl accident, measured by FISH-painting. *Int J Radiat Biol* 70(5):513-516.
- *LeMar HJ, Georgotis WJ, McDermott MT. 1995. Thyroid adaptation to chronic tetraglycine hydroperiodide water purification tablet use. *J Clin Endocrinol Metab* 80:220-223.
- Lengemann FW. 1966. Reduction of iodine transfer to milk of cows after perchlorate ingestion. *J Dairy Sci* 56:753-756.
- Lengemann FW. 1979. Effects of low and high ambient temperatures on metabolism of radioiodine by the lactating goat. *J Dairy Sci* 62:412-415.
- *Lengemann FW, Comar CL. 1964. Metabolism of ¹³¹I by dairy cows during long term daily administration of the radioscope. *Health Phys* 10:55.
- *Lengemann FW, Wentworth RA. 1979. Extremes of environmental temperature and the transfer of radioiodide into milk. *Health Phys* 36:267-271.
- *Leonard JL, Koehrl J. 1996. Intracellular pathways of iodothyronine metabolism. In: Braverman LE, Utiger RD, eds. *Werner and Ingbar's the thyroid: A fundamental and clinical text*. Philadelphia, PA: Lippincott-Raven, 125-161.
- Lequesne M. 1967. [Alsodystrophy of chemotherapeutic origin. Pseudorheumatism due to isoniazid, ethionamide, phenobarbital and radioactive iodine.] *Sem Hop* 43(42):2581-2595. (French)
- *Lessard ET, Miltenberger RP, Conard RA, et al. 1985. Thyroid absorbed dose for people at Rongelap Uterik and Sifo on March 1, 1954. Brookhaven National Library. BNL 51882.
- Leszynsky HE, Gross-Kiesselstein EG, Abrahamov A. 1971. Hyperthyroidism in a 3-month-old baby. *Pediatrics* 47:1069-1083.

9. REFERENCES

- *Leung H-W. 1993. Physiologically-based pharmacokinetic modelling. In: Ballentine B, Marro T, Turner P, eds. General and applied toxicology. Vol. 1. New York, NY: Stockton Press, 153-164.
- Leung PMK, Nikolic M. 1998. Disposal of therapeutic ^{131}I waste using a multiple holding tank system. Health Phys 75(3):315-321.
- LeValley MJ. 1982. Acute toxicity of iodine to channel catfish (*ctalurus punctatus*). Bull Environ Contam Toxicol 29:7-11.
- Levenson D, Gulec S, Sonenberg M, et al. 1994. Peripheral facial nerve palsy after high-dose radioiodine therapy in patients with papillary thyroid carcinoma. Ann Intern Med 120(7):576-578.
- *Levy O, Dai G, Riedel C, et al. 1997. Characterization of the thyroid Na^+/I^- symporter with an anti-COOH terminus antibody. Proc Natl Acad Sci U S A 94:5568-5573.
- *Levy O, De la Vieja A, Carrasco N. 1998a. The Na^+/I^- symporter (NIS): Recent advances. J Bioenerg Biomembr 30(2):195-206.
- Levy O, De la Vieja A, Ginter CS, et al. 1998b. N-linked glycosylation of the thyroid Na^+/I^- symporter (NIS). J Biol Chem 273(35):22657-22663.
- *Levy O, Ginter CS, De la Vieja A, et al. 1998c. Identification of a structural requirement for thyroid Na^+/I^- symporter (NIS) function from analysis of a mutation that causes human congenital hypothyroidism. FEBS Lett 429:36-40.
- Lewitus Z. 1983. Thyroid carcinoma in Israel. Acta Endocrinol Suppl 252:15.
- Lewitus Z, Lubin E, Rechnic J, et al. 1971. The problem of iodine-125 for treatment of thyrotoxicosis. Hormones 2:115-128.
- *Li M, Boyages SC. 1994. Iodide induced lymphocytic thyroiditis in the BB/W rat: Evidence of direct toxic effects of iodide on thyroid subcellular structure. Autoimmunity 18:31-40.
- Li M, Eastman CJ, Boyages SC. 1993. Iodine induced lymphocytic thyroiditis in the BB/W rat: Early and late immune phenomena. Autoimmunity 14:181-187.
- *Li W, Qu C, Jia G, et al. 1987. Endemic goitre in Central China caused by excessive iodine intake. Lancet, August 1:257-258.
- Li W, Xiong JQ, Cohen BS. 1998. The deposition of unattached radon progeny in a tracheobronchial cast as measured with iodine vapor. Aerosol Sci Technol 28:502-510.
- *Libert F, Lefort A, Gerard C, et al. 1989. Cloning, sequencing and expression of the human thyrotropin (TSH) receptor: Evidence for binding of autoantibodies. Biochem Biophys Res Commun 165(3):1250-1255.
- *Libert F, Ruel J, Ludgate M et al. 1987. Complete nucleotide sequence of the human thyroperoxidase-microsomal antigen cDNA. Nucleic Acids Res 15:6735.
- *Lide DR, ed. 2000. CRC handbook of chemistry and physics. 81st ed. Boca Raton, FL: CRC Press.
- *Liesenkotter KP, Gopel W, Bogner U, et al. 1996. Earliest prevention of endemic goiter by iodine supplementation during pregnancy. Eur J Endocrinol 134:443-448.
- Lightner ES, Fisser DA, Giles H, et al. 1977. Intra-amniotic injection of thyroxine (T4) to a human fetus: Evidence for conversion of T4 to reverse T3. Am J Obstet Gynecol 127:487-490.

9. REFERENCES

- Lightowler HJ, Davies GJ, Trevan MD. 1996. Iodine in the diet: Perspectives for vegans. *J R Soc Health* 116:14-20.
- Likhtarev IA, Gulko GM, Kairo IA, et al. 1994. Thyroid doses resulting from the Ukraine Chernobyl accident-Part I: Dose estimates for the population of Kiev. *Health Phys* 66(2):137-146.
- Likhtarev I, Kairo I, Tronko ND, et al. 1998. Thyroid cancer risk to children calculated. *Nature* 392:31-32.
- *Likhtarev IA, Shandala NK, Gulko GM, et al. 1993. Ukrainian thyroid doses after the Chernobyl accident. *Health Phys* 64(6):594-599.
- *Likhtarev IA, Sobolev BG, Kairo IA, et al. 1995. Thyroid cancer in the Ukraine. *Nature* 375:365.
- Lim C-F, Bernard BF, de Jong M, et al. 1993. A furan fatty acid and indoxyl sulfate are the putative inhibitors of thyroxine hepatocyte transport in uremia. *J Clin Endocrinol Metab* 76(2):318-324.
- *Lin JD, Wang HS, Weng HF, et al. 1998. Outcome of pregnancy after radioactive iodine treatment for well differentiated thyroid carcinomas. *J Endocrinol Invest* 21:662-667.
- Lin TJ, Tanaka Y, Aznar R, et al. 1973. Contraceptive effect of intrauterine application of Lugol's solution. *Am J Obstet Gynecol* 116(2):167-174.
- Lin W-Y, Shen Y-Y, Wang S-J. 1996. Short-term hazards of low-dose radioiodine ablation therapy in postsurgical thyroid cancer patients. *Clin Nucl Med* 21(10):780-782.
- *Lind P, Langsteger W, Molnar M, et al. 1998. Epidemiology of thyroid diseases in iodine sufficiency. *Thyroid* 8(12):1179-1183.
- Linder N, Davidovitch N, Reichman B, et al. 1997a. Topical iodine-containing antiseptics and subclinical hypothyroidism in preterm infants. *J Pediatr* 131:434-439.
- Linder N, Sela B, German B, et al. 1997b. Iodine and hypothyroidism in neonates with congenital heart disease. *Arch Dis Child* 77:F239-F240.
- Lindsay S, Nichols CWJ, Chaikoff IL. 1968. Carcinogenic effect of irradiation: Low doses of radioactive iodine on the thyroid gland of the rat and mouse. *Arch Pathol* 85:487-492.
- Lindsay S, Potter GD, Chaikoff IL. 1963. Radioiodine-induced thyroid carcinomas in female rats. *Arch Pathol* 75:20-24.
- *Lindstrom RM, Lutz GJ, Norman BR. 1991. High-sensitivity determination of iodine isotopic ratios by thermal and fast neutron activation. *J Trace Microprobe Tech* 9(1):21-32.
- Ling CC, Li WX, Anderson LL. 1995. The relative biological effectiveness of I-125 and Pd-103. *Int J Radiat Oncol Biol Phys* 32(2):373-378.
- Links JM. 1996. Radiation physics. In: Braverman LE, Utiger RD, eds. *Werner and Ingbar's the thyroid: A fundamental and clinical text*. Philadelphia, PA: Lippincott-Raven, 330-341.
- Linsley GS. 1977. Criteria for safe working with iodine-125. *Radiography* 43(508):91-93.
- Lione A. 1988. Nonprescription drugs as a source of aluminum, bismuth, and iodine during pregnancy. *Reprod Toxicol* 1:243-252.

9. REFERENCES

- *Lipsztein JL, Bertilli L, Melo DR, et al. 1991. Application of in-vitro bioassay for ^{137}Cs during the emergency phase of the Goiania accident. *Health Physics* 60:43-49.
- Little JR, Murray PR, Traynor PS, et al. 1999. A randomized trial of povidone-iodine compared with iodine tincture for venipuncture site disinfection: Effects on rats of blood culture contamination. *Am J Med* 107:119-125.
- Liu J, Liu Y, Barter RA, et al. 1995. Alteration of thyroid homeostasis by UDP-glucuronosyltransferase inducers in rats: A dose-response study. *J Pharmacol Exp Ther* 273:977-985.
- *Liu K, Edwards FM. 1979. Radiation exposure to medical personnel during iodine-125 seed implantation of the prostate. *Radiology* 132:748-749.
- Liu Z, Fu C, Li C, et al. 1982. ^{131}I and ^{132}I carcinogenic effects in rat thyroid glands. *Chin Med J* 95(9):641-648.
- Liu Z, Fu C, Li Z, et al. 1986. Study on late effects of radioiodine on rats. *Sci Sin [B]* XXIX(10):1039-1053.
- Liu Z, Fu C, Li Z, et al. 1987. Carcinogenic effects of ^{131}I , ^{132}I and ^{125}I on rat thyroids. *Chin Med J* 100(2):92-96.
- *Livadas DP, Koutras DA, Souvatzoglou A, et al. 1977. The toxic effects of small iodine supplements in patients with autonomous thyroid nodules. *Clin Endocrinol* 7:121-127.
- *Livingston, AL. 1978. Forage plant estrogens. *J Toxicol Environ Health* 4:301-324.
- LiVolsi VA. 1996. Pathology. In: Braverman LE, Utiger RD, eds. *Werner and Ingbar's the thyroid: A fundamental and clinical text*. Philadelphia, PA: Lippincott-Raven, 497-520.
- LiVolsi VA. 1997. Pathology of thyroid disease. In: Falk SA, ed. *Thyroid disease: Endocrinology, surgery, nuclear medicine, and radiotherapy*. Philadelphia, PA: Lippincott-Raven Publishers, 65-104.
- Lloyd DC, Purrott RJ, Dolphin GW, et al. 1976. A comparison of physical and cytogenetic estimates of radiation dose in patients treated with iodine-131 for thyroid carcinoma. *Int J Radiat Biol* 30(5):473-485.
- Lloyd RD, Tripp DA, Kerber RA. 1996. Limits of fetal thyroid risk from radioiodine exposure. *Health Phys* 70(4):559-562.
- Lloyd WE. 1982. Toxicology of ethylenediamine dihydriodide [Letter]. *J Am Vet Med Assoc* 180(5):476,478.
- Lo MT, Hill DC. 1971. Effect of dietary rapeseed meal on the serum proteins of rats. *Can J Physiol Pharmacol* 49:1100-1105.
- Loeb JN. 1996a. Metabolic changes in hypothyroidism. In: Braverman LE, Utiger RD, eds. *Werner and Ingbar's the thyroid: A fundamental and clinical text*. Philadelphia, PA: Lippincott-Raven, 858-862.
- Loeb JN. 1996b. Metabolic changes in thyrotoxicosis. In: Braverman LE, Utiger RD, eds. *Werner and Ingbar's the thyroid: A fundamental and clinical text*. Philadelphia, PA: Lippincott-Raven, 687-693.
- Long Y, France J-L, Giraud A. 1990. Inhibition of *N*-glycan processing affects iodide organification in porcine thyroid cells. *Mol Cell Endocrinol* 73:217-224.

9. REFERENCES

- *Longcope C. 2000a. The male and female reproductive systems in hypothyroidism. In: Braverman LE, Utiger RD, eds. *Werner and Ingbar's the thyroid: A fundamental and clinical text*. 8th Philadelphia, PA: Lippincott-Raven, 824-827.
- *Longcope C. 2000b. The male and female reproductive systems in thyrotoxicosis. In: Braverman LE, Utiger RD, eds. *Werner and Ingbar's the thyroid: A fundamental and clinical text*. 8th Philadelphia, PA: Lippincott-Raven, 653-658.
- *Lopez Saez MP, de Barrio M, Zubeldia JM, et al. 1998. Acute IgE-mediated generalized urticaria-angioedema after topical application of povidone-iodine. *Allergol Immunopathol (Madr)* 26(1):23-26.
- LoPresti JS, Singer PA. 1997. Physiology of thyroid hormone synthesis, secretion, and transport. In: Falk SA, ed. *Thyroid disease: Endocrinology, surgery, nuclear medicine, and radiotherapy*. Philadelphia, PA: Lippincott-Raven Publishers, 29-40.
- Loran M, Kleinmann K. 1975. Semiquantitative test of iodine vapor above complexed iodine solutions. *Am J Hosp Pharm* 32:431-432.
- Lowdell CP, Dobbs HJ, Spathis GS, et al. 1985. Low-dose ¹³¹I in treatment of Graves' disease. *J R Soc Med* 78:197-202.
- *Luckett LW, Stotler RE. 1980. Radioiodine volatilization from reformulated sodium iodide I-131 oral solution. *J Nucl Med* 21:477-479.
- Lueprasitsakul W, Abend S, Alex S, et al. 1990. Effect of thalidomide on the incidence of iodine-induced and spontaneous lymphocytic thyroiditis and spontaneous diabetes mellitus in the BB/Wor rat. *Acta Endocrinol* 123:79-83.
- Lundell G, Holm L-E. 1980. Hypothyroidism following ¹³¹I therapy for hyperthyroidism in relation to immunologic parameters. *Acta Radiol Oncol* 19:449-454.
- Lundell G, Jonsson J. 1973. Thyroid antibodies and hypothyroidism in ¹³¹I therapy for hyperthyroidism. *Acta Radiol Ther Phys Biol* 12(5):443-453.
- Lundell G, Holm L-E, Ljunggren J-G, et al. 1981. Incidence of hypothyroidism after ¹³¹I therapy for hyperthyroidism. *Acta Radiol Oncol* 20(4):225-230.
- Lupulescu A, Petrovici A. 1964. The fine structure of thyroid tumours induced by low iodine diet in rats. *Acta Anat* 57:294-305.
- Lupulescu A, Stebner F. 1974. Effect of synthetic salmon calcitonin in iodine metabolism in rabbits. *Proc Soc Exp Biol Med* 146:56-58.
- Luther GW, Swartz CB, Ullman WJ. 1988. Direct determination of iodide in seawater by cathodic stripping square wave voltammetry. *Anal Chem* 60:1721-1724.
- Lutz GJ, Rook HL, Lindstrom RM. 1984. Determination of I-129 at natural levels by thermal neutron activation analysis. *J Trace Microprobe Tech* 2(1):33-51.
- Lybeck H, Leppaluoto J, Virkkunen P, et al. 1973. Suppression of TRH-mediated thyroidal release of ¹³¹I by a synthetic analog. *Neuroendocrinology* 12:366-370.
- Maas LC, Gelzayd EA. 1978. Endoscopic removal of an ulcerated appendiceal stump. *JAMA* 240(3):248-249.

9. REFERENCES

- Maayan ML. 1977. TSH and catecholamines: Independent effects on active transport and iodine organification in isolated thyroid cells. *Acta Endocrinol* 86:763-767.
- Maayan ML, Ingbar SH. 1968. Epinephrine: Effect on uptake of iodine by dispersed cells of calf thyroid gland. *Science* 162:124-125.
- Maayan ML, Miller SL, Ingbar SH. 1971. Effects of serotonin on iodide and intermediary metabolism in isolated thyroid cells. *Endocrinology* 88:620-626.
- Maayan ML, Shapiro R, Ingbar SH. 1973. Epinephrine precursors: Effects on the iodine and intermediary metabolism of isolated calf thyroid cells. *Endocrinology* 92:912-916.
- Maayan ML, Volpert EM, From A. 1981. Norepinephrine and thyrotropin effects on the thyroid *in vitro*: Simultaneous stimulation of iodide organification and antagonism of thyroxine release. *Endocrinology* 109:930-934.
- Macaron C. 1996. An epidemic of hyperthyroidism following salt iodination in Lebanon. *J Med Liban* 44(4):200-202.
- *Machta L. 1963. Meteorological processes in the transport of weapon radionuclides. *Health Physics* 9:43.
- Madaoui S, Rappaport L, Nunez J. 1974. Prostaglandins and *in vitro* TSH-dependent iodide binding by rat thyroid glands. *Biochimie* 56:109-113.
- Maekoshi H, Orito T, Nishizawa K, et al. 1979. [Measurement of ¹³¹I concentration in saliva of a patient and monitoring of exposure and contamination in a ward.] *Radioisotopes* 28(3):180-183. (Chinese)
- *Magnusson RP, Chazenbalk GD, Gestautas J et al. 1987. Molecular cloning of the complementary deoxyribonucleic acid from human thyroid peroxidase. *Mol. Endocrinol.* 1:856.
- Mahillon I, Peers W, Bourdoux P, et al. 1989. Effect of vaginal douching with povidone-iodine during early pregnancy on the iodine supply to mother and fetus. *Biol Neonate* 56:210-217.
- Mahn DC, Vallet JL. 1997. Vitamin and mineral transfer during fetal development and the early postnatal period in pigs. *J Anim Sci* 75:2731-2738.
- Maienchenko AF, Seregin VV, Kuz'mina TS. 1976. [Effect of uranium on the metabolism of radioactive and stable iodine in the thyroid gland.]. *Dokl Akad Nauk SSSR* 20(4):373-376.
- Maier H, Bihl H. 1987. Effect of radioactive iodine therapy on parotid gland function. *Acta Otolaryngol (Stockh)* 103:318-324.
- Maillie HD. 1986. Should the annual limit on intake for ¹²⁵I and ¹³¹I be lowered? [Letter]. *Health Phys* 50(3):425.
- Makhon'ko KP, Kim VM. 1997. Calculation of the dose load to the thyroid gland from consumption of milk after the Chernobyl accident. *At Energ (English)* 83(1):534-537. Translation from *Atomnaya Energiya*, 83(1):57-60.
- Malarbet JL, Aurengo A, Roy M, et al. 1998. [Dose coefficients from incorporated iodine-129. Influence of dietary intake.] *Radioprotection* 33(1):15-33. (French)
- Malcolm RL. 1989. The relative importance of pH, charge, and water solubility on the movement of organic solutes in soils and ground water. *Ecol Stud* 73:288-301.

9. REFERENCES

- Malinauskas AP, Bell JT. 1987. The chemistry of fission-product iodine under nuclear reactor accident conditions. *Nuclear Safety* 28(4):505-514.
- Malone JF. 1993. Consequences of iodine fall out: Dosimetric and radiobiological considerations. In: Delange F et al, ed. *Iodine deficiency in Europe*. New York, NY: Plenum Press, 229-235.
- Malone JF, Cullen MJ. 1976. Two mechanisms for hypothyroidism after ^{131}I therapy. *Lancet* 2(7976):73-75.
- Malone JF, Cullen MJ. 1977. Hypothyroidism after ^{125}I therapy [Letter]. *Ann Intern Med* 86(6):823.
- Maloof F, Dobyns BM, Vickery AL. 1952. The effect of various doses of radioactive iodine on the function and structure of the thyroid of the rat. *Endocrinology* 50(6):612-638.
- Malpani BL, Samuel AM, Jasiwar RK. 1998. Salivary gland scintigraphy after radioiodine therapy. *Nucl Med Commun* 19:183-184.
- *Mandel SJ, Mandel L. 1999. Persistent sialadenitis after radioactive iodine therapy: Report of two cases. *J Oral Maxillofac Surg* 57:738-741.
- Mandell RB, Mandell LZ, Link CJJ. 1999. Radioisotope concentrator gene therapy using the sodium/iodide symporter gene. *Cancer Res* 59:661-668.
- Mandell R, McCann L, Link CJ. 1997. Gene therapy of cancer by retroviral transfer and expression of the rat sodium/iodide symporter (NIS) [Abstract]. *Proc Am Assoc Cancer Res* 38:381.
- *Mandò PA, Poggi G. 1988. *In vivo* measurements of ^{131}I build-up in human thyroids after the Chernobyl reactor accident. *Health Phys* 54(2):207-209.
- Mangkoewidjojo S. 1979. I. Pathologic effects of polybrominated biphenyls in rats fed a diet containing excessive iodine. II. Pathologic changes in calves after oral administration of excessive iodine for six months. Ph.D. Dissertation, Michigan State University. 193 p.
- Mangkoewidjojo S, Sleight SD, Convey EM. 1980. Pathologic features of iodide toxicosis in calves. *Am J Vet Res* 41(7):1057-1061.
- Manley SW, Bourke JR, Huxham GJ. 1987. Ionic mechanisms regulating thyroidal secretion: Effects of ouabain and medium sodium concentration on radioiodine release from cultured porcine thyroid cells. *J Endocrinol* 112:399-405.
- Manley SW, Huxham GJ, Bourke JR. 1986. Role of sodium influx in thyrotrophin action: Effects of the sodium channel agonist veratridine and thyrotropin on radioiodine turnover and membrane potential in cultured porcine thyroid cells. *J Endocrinol* 110:459-466.
- Mano MT, Potter BJ, Belling GB, et al. 1989. The effect of thyroxine, 3,5-dimethyl-3'-isopropyl-L-thyronine and iodized oil on fetal brain development in the iodine-deficient sheep. *Acta Endocrinol* 121:7-15.
- Manso PG, Fulanetto RP, Wolosker AMB, et al. 1998. Prospective and controlled study of ophthalmopathy after radioiodine therapy for Graves' hyperthyroidism. *Thyroid* 8(1):49-52.
- Many MC, Deneff JF. 1992. Iodine and goiter involution. *Thyroidology* 4:23-26.
- Many M-C, Deneff JS, Hamudi S, et al. 1986. Effects of iodide and thyroxine on iodine-deficient mouse thyroid: A morphological and functional study. *J Endocrinol* 110:203-210.

9. REFERENCES

- Many M-C, Deneff J-F, Haumont S, et al. 1985. Morphological and functional changes during thyroid hyperplasia and involution in C3H mice: Effects of iodine and 3,5,3'-triiodothyronine during involution. *Endocrinology* 116:798-806.
- Many M-C, Maniratunga S, Varis I, et al. 1995. Two-step development of Hashimoto-like thyroiditis in genetically autoimmune prone non-obese diabetic mice: effects of iodine-induced cell necrosis. *J Endocrinol* 147:311-320.
- Many M-C, Papadopoulos J, Martin C, et al. 1991. Iodine induced cell damage in mouse hyperplastic thyroid is associated to lipid peroxidation. In: Gordon A, Gross J, Hennemann G, eds. *Progress in thyroid research*. Rotterdam, the Netherlands: Balkema, 635-638.
- *Marcocci C, Chiovato L. 2000. The epidemiology of thyroid diseases. In: Braverman LE, Utiger RD, eds. *Werner and Ingbar's the thyroid: A fundamental and clinical text*. 8th ed. Philadelphia, PA: Lippincott-Raven, 474-482.
- Marcocci C, Cohen JL, Grollman EF. 1984. Effect of actinomycin D on iodide transport in FRTL-5 thyroid cells. *Endocrinology* 115:2123-2132.
- Marcocci C, Luini A, Santisteban P, et al. 1987. Norepinephrine and thyrotropin stimulation of iodide efflux in FRTL-5 thyroid cells involves metabolites of arachidonic acid and is associated with the iodination of thyroglobulin. *Endocrinology* 120:1127-1133.
- Margulies K, Schirger J, Burnett JJ. 1991. Radiocontrast-induced nephropathy: Current status and future prospects. *Int Angiol* 11:20-25.
- Marine D, Feiss HO. 1915. The absorption of potassium iodide by perfused thyroid glands and some of the factors modifying it. *J Pharmacol Exp Ther* 7:557-576.
- Mariotti S, Martino E, Francesconi M, et al. 1986. Serum thyroid autoantibodies as a risk factor for development of hypoparathyroidism after radioactive iodine therapy for single thyroid 'hot' nodule. *Acta Endocrinol* 113:500-507.
- *Markou K, Georgopoulos, Kyriazopoulou V, et al. 2001. Iodine-induced hypothyroidism. *Thyroid* 11(5): 501-510.
- *Maros L, Káldy M, Igaz S. 1989. Simultaneous determination of bromide and iodide as acetone derivatives by gas chromatography and electron capture detection in natural waters and biological fluids. *Anal Chem* 61:733-735.
- *MARSSIM. 1997. Multi-agency radiation survey and site investigation manual. Nuclear Regulatory Commission, Energy Department, Environmental Protection Agency, and Defense Department. 660p. NUREG 1575, EPA 402 R 97 016.
- *Marter WL. 1993. Savannah River site radioiodine atmospheric releases and offsite maximum doses (U). Westinghouse Savannah River Company, Savannah River Laboratory, SRL-ETS-900317 (NTIS/DE93004259), pp. 1-35.
- Martin ES, Godley PJ. 1993. Letter to the editor. *N Engl J Med* 328(5):355-356.
- Martin JE, Fenner FD. 1997. Radioactivity in municipal sewage and sludge. *Public Health Reports* 112:308-316.
- Martin MM, Matus RN. 1966. Neonatal exophthalmos with maternal thyrotoxicosis. *Am J Dis Child* 111:545-547.

9. REFERENCES

*Martin MM, Rento RD. 1962. Iodide goiter with hypothyroidism in 2 newborn infants. *J Pediatr* 61:94-99.

Martin RF, Haseltine WA. 1981. Range of radiochemical damage to DNA with decay of iodine-125. *Science* 213:896-898.

*Martin WE, Turner FB. 1964. Project Sedan. Food-chain relationships of iodine-131 in Nevada following the Sedan test of July 1962. NTIS AD-A076 363/1 (AEC-PNE-236F), 5-58.

Martinez-Galan JR, Pedraza P, Santacana M, et al. 1997. Early iodine deficiency on radial glial cells of the hippocampus of the rat fetus. *J Clin Invest* 99:2701-2709.

Martino E, Bartalena L, Faglia G, et al. 1996. Central hypothyroidism. In: Braverman LE, Utiger RD, eds. *Werner and Ingbar's the thyroid: A fundamental and clinical text*. Philadelphia, PA: Lippincott-Raven, 779-791.

Martino E, Bartalena L, Mariotti S, et al. 1988. Radioactive iodine thyroid uptake in patients with amiodarone-iodine-induced thyroid dysfunction. *Acta Endocrinol* 119:167-173.

Martins MC, Lima N, Knobel M, et al. 1989. Natural course of iodine-induced thyrotoxicosis (jodbasedow) in endemic goiter area: A 5 year follow-up. *J Endocrinol Invest* 12:239-244.

Martmer EE, Corrigan KE, Charbeneau HP, et al. 1956. A study of the uptake of iodine (I-131) by the thyroid of premature infants. *Pediatrics* 17:503-509.

Maruyama H, Yamamoto I. 1992. Suppression of ¹²⁵I-uptake in mouse thyroid by seaweed feeding: Possible preventative effect of dietary seaweed on internal radiation injury of the thyroid by radioactive iodine. *Kitasato Arch Exp Med* 65(4):206-216.

Mashita K, Kawamura S, Kishino B, et al. 1982. Effects of iodide and propylthiouracil on the release of 3,5,3'-triiodothyronine and of cyclic adenosine 3',5'-monophosphate from perfused rat thyroids. *Endocrinology* 110:1023-1029.

Masri MT, Menne M, Rooney BL, et al. 1995. A simplified method for treating Graves' disease with radioactive ¹³¹I. *Wis Med J* 94(1):21-25.

Mathieu I, Caussin J, Smeesters P, et al. 1997. Doses in family members after ¹³¹I treatment. *Lancet* 350(9084):1074-1075.

Matovinovic J, Nishiyama RH, Hill HC, et al. 1969. The role of sex and iodine deficiency in the growth and function of the rat thyroid transplantable tumor. *Cancer Res* 29:1398-1406.

Matsumoto T, Itoh H, Akiba Y. 1969. Effect of (-)-5-vinyl-2-oxazolidinethione on the radioiodine metabolism in growing chicks. *Poult Sci* 48(3):1061-1069.

Matsunaga E, Shiota K. 1980. Search for maternal factors associated with malformed human embryos: A prospective study. *Teratology* 21:323-331.

*Maxon HR, Saenger E. 1996. Biologic effects of radioiodines on the human thyroid gland. In: Braverman LE, Utiger RD, eds. *Werner and Ingbar's the thyroid: A fundamental and clinical text*. Philadelphia, PA: Lippincott-Raven, 342-351.

*Maxon HR, Saenger E. 2000. Biologic effects of radioiodines on the human thyroid gland. In: Braverman LE, Utiger RD, eds. *Werner and Ingbar's the thyroid: A fundamental and clinical text*. Philadelphia, PA: Lippincott-Raven, 345-354.

9. REFERENCES

- Maxon HR, Saenger EL, Thomas SR, et al. 1980. Clinically important radiation-associated thyroid disease: A controlled study. *JAMA* 244(16):1802-1805.
- Maxon HR, Thomas SR, Hertzberg VS, et al. 1983. Relation between effective radiation dose and outcome of radioiodine therapy for thyroid cancer. *N Engl J Med* 309(16):937-941.
- Maxon R, Thomas SR, Maxon H. 1987. Effect of gut retention on the effective body half-time of iodine-131 in thyroid cancer patients. *J Nucl Med Technol* 15:13-15.
- Maxon HR, Thomas SR, Saenger EL, et al. 1977. Ionizing irradiation and the induction of clinically significant disease in the human thyroid gland. *Am J Med* 63:967-978.
- May W, Wu D, Eastman C, et al. 1990. Evaluation of automated urinary iodine methods: Problems of interfering substances identified. *Clin Chem* 36:865-869.
- *Mayr U, Butsch A, Schneider S. 1992. Validation of two in vitro test systems for estrogenic activities with zearalenone, phytoestrogens and cereal extracts. *Toxicology* 74:135-149.
- Mazzaferri E. 1996a. Radioiodine and other treatments and outcomes. In: Braverman LE, Utiger RD, eds. *Werner and Ingbar's the thyroid: A fundamental and clinical text*. Philadelphia, PA: Lippincott-Raven, 937-938.
- Mazzaferri EL. 1996b. Radioiodine and other treatments and outcomes. In: Braverman LE, Utiger RD, eds. *Werner and Ingbar's the thyroid: A fundamental and clinical text*. Philadelphia, PA: Lippincott-Raven, 922-945.
- Mazzaferri Z. 1996. Radioiodine and other treatments and outcomes. In: Braverman LE, Utiger RD, eds. *Werner and Ingbar's the thyroid*. Philadelphia, PA: Lippincott Raven, 937-939.
- McAlexander RA, Stevenson JK, Olch PD, et al. 1962. Accelerated mammary tumor development in C3H mice fed an iodine-deficient diet. *Surg Forum* 13:105-106.
- McBride JA. 1964. Acute leukaemia after treatment for hyperthyroidism with radioactive iodine. *Br Med J* 2:736.
- McCarthy JS, Fregly MJ, Nechay BR. 1967. Effect of diuretics on renal iodide excretion by rats and dogs. *J Pharmacol Exp Ther* 158(2):294-304.
- McCauley EH, Linn JG, Goodrich RD. 1973. Experimentally induced iodide toxicosis in lambs. *Am J Vet Res* 34(1):65-70.
- McClain RM. 1989. The significance of hepatic microsomal enzyme induction and altered thyroid function in rats: Implications for thyroid gland neoplasia. *Toxicol Pathol* 17(2):294-306.
- McClain RM. 1992. Thyroid gland neoplasia: Non-genotoxic mechanisms. *Toxicol Lett* 64/65:397-408.
- McClain RM, Rice JM. 1999. A mechanistic relationship between thyroid follicular cell tumours and hepatocellular neoplasms in rodents. In: Capen CC, Dybing E, Rice JM, et al., eds. *Species differences in thyroid, kidney and urinary bladder carcinogenesis*. Lyon, France: International Agency for Research on Cancer, 61-68.
- *McClellan RO, Rupprecht FC, eds. 1968. Radioiodine metabolism in the beagle dog - the importance of age and mode of ¹³¹I exposure. Fission product inhalation program annual report 1967-1968. Albuquerque, NM: Lovelace Foundation for Medical Education and Research, 122-127.
- McClintock JT. 1974. Thyroid cancer after radioactive iodine therapy [Letter]. *JAMA* 228(3):290.

9. REFERENCES

- McComb DE, Whittum JA. 1973. Chick-embryo deaths traced to tincture of iodine. *J Infect Dis* 127(5):581.
- McCruden DC, Hilditch TE, Connell JMC, et al. 1985. Kinetics of [¹²³I]iodide uptake and discharge by perchlorate in studies of inhibition of iodide binding by antithyroid drugs. *Acta Endocrinol* 110:499-504.
- McCullagh FP, Jelden GL, Rodriguez-Antunez A. 1976. Incidence of hypothyroidism following small doses of ¹³¹I in the treatment of Graves' disease. *Ohio State Med J* 72(9):538-540.
- McDermott MT. 1997. Oncogenes and thyroid cancer. In: Falk SA, ed. *Thyroid disease: Endocrinology, surgery, nuclear medicine, and radiotherapy*. Philadelphia, PA: Lippincott-Raven Publishers, 231-239.
- McDermott MT, Kidd GS, Dodson LE, et al. 1983. Radioiodine-induced thyroid storm. *Am J Med* 75:353-359.
- McDougall IR. 1974. Thyroid cancer after iodine-131 therapy [Letter]. *JAMA* 227(4):438.
- McDougall IR. 1977. In comment: [Letter]. *Ann Intern Med* 86(6):823-824.
- McDougall IR. 1993. Does radioiodine cause the ophthalmopathy of Graves' disease? *Nucl Med Commun* 14:79-81.
- McDougall IR. 1997. 74 MBq radioiodine ¹³¹I does not prevent uptake of therapeutic doses of ¹³¹I (i.e. it does not cause stunning) in differentiated thyroid cancer. *Nucl Med Commun* 18:505-512.
- McDougall IR. 1999. Cancer deaths after ¹³¹I therapy for thyrotoxicosis. *Nucl Med Commun* 20:407-409.
- *McDougall IR, Cavalieri RR. 2000. In vivo radionuclide tests and imaging. In: Braverman LE, Utiger RD, eds. *Werner and Ingbar's the thyroid: A fundamental and clinical text*. Philadelphia, PA: Lippincott-Raven, 355-375.
- McDougall IR, Greig WR. 1976. ¹²⁵I therapy in Graves' disease: Long-term results in 355 patients. *Ann Intern Med* 85:720-723.
- McDougall IR, Greig WR, Gillespie FC. 1971a. Persistence of ¹²⁵I in thyroid. *N Engl J Med* 286(3):161. See also 79280; Van Middlesworth.
- McDougall IR, Kennedy JS, Thomson JA. 1971b. Thyroid carcinoma following iodine-131 therapy. Report of a case and review of the literature. *J Clin Endocrinol* 33:287-292.
- McDougall IR, Nelsen TS, Kempson RL. 1981. Papillary carcinoma of the thyroid seven years after I-131 therapy for Graves' disease. *Clin Nucl Med* 6(8):368-371.
- McFarlane IA, Shalet SM, Beardwell CG, et al. 1979. Transient hypothyroidism after iodine-131 treatment for thyrotoxicosis. *Br Med J* 2:421.
- McGavack TH, Seegers W. 1959. Status of the thyroid gland after age 50. *Metabolism* 8:136-150.
- McGhee D, John S, Williams JB. 1998. Expression of the sodium-dependent iodide symporter in rat organs and identification of a potential isoform generated by alternative mRNA splicing. In: *The Endocrine Society-annual meeting, program and abstracts*. Bethesda, MD: Endocrine Society.
- McGuire RA, Berman M. 1978. Maternal, fetal, and amniotic fluid transport of thyroxine, triiodothyronine, and iodide in sheep: A kinetic model. *Endocrinology* 103(2):567-576.

9. REFERENCES

- McKenzie JM, Zakarija M. 1996. Antibodies in autoimmune thyroid disease. In: Braverman LE, Utiger RD, eds. *Werner and Ingbar's the thyroid: A fundamental and clinical text*. Philadelphia, PA: Lippincott-Raven, 416-432.
- McKillop JH, Doig JA, Kennedy JS, et al. 1978. Laryngeal malignancy following iodine-125 therapy for thyrotoxicosis. *Lancet* 2(8101):1177-1179.
- *McLachlan SM, Rapaport B. 1992. The molecular biology of thyroid peroxidase: Cloning, expression and role as an autoantigen in autoimmune thyroid disease. *Endocr. Rev.* 13:192-206.
- *McLachlan SM, Rapoport B. 1996. Genetic factors in thyroid disease. In: Braverman LE, Utiger RD, eds. *Werner and Ingbar's the thyroid: A fundamental and clinical text*. Philadelphia, PA: Lippincott-Raven, 483-496.
- Meck RA, Chen MS, Kenny PJ. 1985. Criteria for the administration of KI for thyroid blocking of radioiodine. *Health Phys* 48(2):141-157.
- Medeiros-Neto GA. 1971. Respiration and iodine transport by thyroid slices as influenced by ouabain, succinate, alpha-ketoglutarate, sodium and potassium. *Acta Physiol Latinoam* 21:126-136.
- Medeiros-Neto G. 1994. Letter to the Editor. *Clin Endocrinol* 40:435.
- Medeiros-Neto GA, Billerbeck AE, Wajchenberg BL, et al. 1993. Defective organification of iodide causing hereditary goitrous hypothyroidism. *Thyroid* 3(2):143-159.
- Medeiros-Neto GA, Hollander CS, Knobel M, et al. 1978. Effects of iodides on the hypothalamic-pituitary-thyroid axis in neurological endemic cretinism: Evidence for compensated thyroidal failure in adult life. *Clin Endocrinol* 8:213-218.
- *Mehta RD, von Borstel RC. 1982a. Effect of growth phase and different solvents on the genetic activity and cell toxicity of diethylstilbesterol in *saccharomyces cerevisiae*. *Environ Mutagen* 4:417.
- *Mehta RS, von Borstel RC. 1982b. Genetic activity of diethylstilbesterol in *saccharomyces cerevisiae*. Enhancement of mutagenicity by oxidizing agents. *Mutat Res* 92:49-61.
- *Meier CA, Burger AG. 1996. Effects of pharmacologic agents on thyroid hormone homeostasis. In: Braverman LE, Utiger RD, eds. *Werner and Ingbar's the thyroid: A fundamental and clinical text*. Philadelphia, PA: Lippincott-Raven, 276-286.
- *Meinhold H, Beckert A, Wenzel KW. 1981. Circulating diiodotyrosine: Studies of its serum concentration, source, and turnover using radioimmunoassay after immunoextraction. *J Clin Endocrinol Metab* 53(6):1171-1178.
- *Meinhold H, Gramm HJ, Meissner W, et al. 1991. Elevated serum diiodotyrosine (DIT) in severe infections and sepsis: DIT, a possible new marker of leukocyte activity. *J Clin Endocrinol Metab* 72:945-953.
- *Meinhold H, Olbricht T, Schwartz-Porsche D. 1987. Turnover and urinary excretion of circulating diiodotyrosine. *J Clin Endocrinol Metab* 64(4):794-800.
- Mello RS, Callisen H, Winter J, et al. 1983. Radiation dose enhancement in tumors with iodine. *Med Physics* 10(1):75-78.
- *Mendel CM, Weisiger RA, Cavalieri RR. 1988. Uptake of 3,5,3'-triiodothyronine by the perfused rat liver: Return to the free hormone hypothesis. *Endocrinology* 123:1817-1824.

9. REFERENCES

- Mendel CM, Weisiger RA, Jones AL, et al. 1987. Thyroid hormone-binding proteins in plasma facilitate uniform distribution of thyroxine within tissues: A perfused rat liver study. *Endocrinology* 120:1742-1749.
- Mercantini ES. 1970. Iododerma from seafood. *Can Med Assoc J* 102:759-760.
- *Merkle J, Zeller H. 1979. Absence of povidone-iodine induced mutagenicity in mice and hamsters. *J Pharm Sci* 68:100-102.
- Merwin SE, Balonov MI. 1993. *The Chernobyl papers: Vol. I. Doses to the Soviet population and early health effects studies.* Richland, WA: Research Enterprises.
- Mestdagh C, Many M-C, Halpern S, et al. 1990. Correlated autoradiographic and ion-microscopic study of the role of iodine in the formation of "cold" follicles in young and old mice. *Cell Tissue Res* 260:449-457.
- Meyer MA. 1994. Re: Cancer risk after iodine-131 therapy for hyperthyroidism [Letter]. *J Natl Cancer Inst* 86(13):1026-1027.
- Michelangeli VP, Poon C, Topliss DJ, et al. 1995. Specific levels of radioiodine treatment on TSAb and TBAb levels in patients with Graves' disease. *Thyroid* 5(3):171-176.
- Mikkonen R. 1998. Incidence and risk factors for delayed allergy-like reactions to x-ray contrast media adult and pediatric populations. *Pharmacoepidemiol Drug Saf* 7:S11-S15.
- Mikulecky M, Beno M, Komornik I. 1993. Time delay of maximal human thyroid ¹³¹I uptake after the Chernobyl accident. *Naturwissenschaften* 80:125-127.
- *Miller JK, Swanson EW. 1963. Some factors affecting iodine secretion in milk. *J Dairy Sci* 46:927.
- Miller KL, Coen PE, White WJ, et al. 1989. Effectiveness of skin absorption of tincture of I in blocking radioiodine from the human thyroid gland. *Health Phys* 56(6):911-914.
- Miller KL, White WJ, Lang CM, et al. 1985. Skin exposure to I blocks thyroid uptake to ¹³¹I. *Health Phys* 49(5):791-794.
- Miller M. 1998. Risk modeling can be key to determining radiation exposures. *J Natl Cancer Inst* 90(21):1596-1598.
- Miller WJ. 1975. New concepts and developments in metabolism and homeostasis of inorganic elements in dairy cattle. A review. *J Dairy Sci* 58(10):1549-1560.
- Mills I, Sherwin JR. 1985. A comparison of the mechanisms of alpha-adrenergic inhibition of thyrotropin-stimulated adenosine 3',5'-monophosphate in cat, rat, mouse, hamster, beef, and pig tissues with the stimulatory effect of epinephrine on beef thyroid iodination: Evidence for multiple, species-specific adrenergic mechanisms. *Endocrinology* 116:1310-1315.
- *Minelli R, Braverman LE, Guiberti T, et al. 1997. Effects of excess iodine administration on thyroid function in euthyroid patients with a previous episode of thyroid dysfunction induced by interferon-alpha treatment. *Clin Endocrinol* 47:357-361.
- *Minelli R, Braverman LE, Valli MA, et al. 1999. Recombinant interferon alpha (rIFN-alpha) does not potentiate the effect of iodine excess on the development of thyroid abnormalities in patients with HCV chronic active hepatitis. *Clin Endocrinol* 50:95-100.

9. REFERENCES

- Misaki T, Miyamoto S, Alam MS, et al. 1996. Tumoricidal cytokines enhance radioiodine uptake in cultured thyroid cancer cells. *J Nucl Med* 37(4):646-648.
- Mittag TW, Guo W-B, Taniguchi T. 1993. Interaction of vanadate and iodate oxyanions with adenylyl cyclase of ciliary processes. *Biochem Pharmacol* 45(6):1311-1316.
- Mityukova TA, Astakhova LN, Asenchyk LD, et al. 1995. Urinary iodine excretion in Belarus children. *Eur J Endocrinol* 133:216-217.
- Miura S, Hara Y, Iitaka M, et al. 1991. Disturbance of thyroidal iodine metabolism in BB/W rat. *Endocrinol Jpn* 38:647-653.
- *Miyake Y, Tsunogai S. 1963. Evaporation of Iodine from the ocean. *Journal of Geophysical Research* 68:3989.
- Miyake Y, Eguchi W, Adachi M, et al. 1979. Effect of carbon dioxide on the absorption rate and mechanism of iodine vapor. *J Chem Eng Jpn* 12(6):436-442.
- *Miyazaki A, Bansho K. 1987. Differential determination of trace amounts of iodide and iodate in water by solvent extraction-inductively coupled plasma atomic emission spectrometry. *Spectrochim Acta, Part B* 42B:227-233.
- Mizukami Y, Michigishi T, Nonomura A, et al. 1993. Iodine-induced hypothyroidism: A clinical and histological study of 28 patients. *J Clin Endocrinol Metab* 76(2):466-471.
- M'Kacher R, Legal J-D, Schlumberger M, et al. 1997. Sequential biological dosimetry after a single treatment with iodine-131 for differentiated thyroid carcinoma. *J Nucl Med* 38:377-380.
- M'Kacher R, Schlumberger M, Legal J-D, et al. 1998. Biologic dosimetry in thyroid cancer patients after repeated treatments with iodine-131. *J Nucl Med* 39:825-829.
- *Mochizuki Y, Mowafy R, Pasternack B. 1963. Weights of human thyroids in New York City. *Health Phys.* 9:1299-1301.
- *Moiseyev IT, Tikhomirov FA, Perevezentsev VM, Rerikh LA. 1984. Role of soil properties, interspecific plant differences, and other factors affecting the accumulation of radioactive iodine in crops. *Soviet Soil Science* 16:60-66.
- *Momotani N, Hisaoka T, Noh J, et al. 1992. Effects of iodine on thyroid status of fetus *versus* mother in treatment of Graves' disease complicated by pregnancy. *J Clin Endocrinol Metab* 75(3):738-744.
- Monakhov AS. 1988. [Cytogenetic and blastomogenic effects of ⁴⁵Ca and ¹³¹I administered to rats.] *Eksp Onkol* 10(4):27-30. (Russian)
- *Moneret-Vautrin DA, Mata E, Gerard H, et al. 1989. Probable allergy to polyvidon, responsible for a reaction to iodinated contrast medium: A case of asthma after hysterosalpingography. *Allerg Immunol* 21(5): 198-199. (French)
- *Moody KD, Miller KL, White WJ, et al. 1988. The effects of topical povidone I solution on serum iodide levels and thyroid uptake of ¹³¹I in dogs. *Health Phys* 55(1):9-13.
- Mooij P, De Wit HJ, Bloot AM, et al. 1993a. Iodine deficiency induces thyroid autoimmune reactivity in Wistar rats. *Endocrinology* 133(3):1197-1204.

9. REFERENCES

- Mooij P, De Wit HJ, Drexhage HA. 1993b. An excess of dietary iodine accelerates the development of a thyroid-associated lymphoid tissue in autoimmune prone BB rats. *Clin Immunol Immunopathol* 69(2):189-198.
- Mooij P, De Wit HJ, Drexhage HA. 1994. A high iodine intake in Wistar rats results in the development of a thyroid-associated ectopic thymic tissue and is accompanied by a low thyroid autoimmune reactivity. *Immunology* 81:309-316.
- Moore MJ. 1975. Leukemia incidence in adults not increased after ^{131}I . *N Engl J Med* 292(25):1353-1354.
- Morales de Villalobos LM, Campos G, Ryder E. 1986. Effect of chronic ingestion of iodide during pregnancy and lactation on rat pup brain enzymes. *Enzyme* 35:96-101.
- *Moran JE, Oktay S, Santschi PH, et al. 1999. Atmospheric dispersal of ^{129}I from nuclear fuel reprocessing facilities. *Environ Sci Technol* 33:2536-2542.
- Moreno AJ, Hartshome MF, Yedinak MA, et al. 1986. Tinea corporis overlying the thyroid gland after radioiodine (^{131}I) treatment of Graves' disease. *Cutis* 37(4):271-273.
- *Morgan A, Morgan DJ, Black A. 1968. A study on the deposition, translocation and excretion of radioiodine inhaled as iodine vapour. *Health Phys* 15:313-322.
- *Morgan A, Morgan DJ, Evans JC, et al. 1967a. Studies on the retention and metabolism of inhaled methyl iodide-II: Metabolism of methyl iodide. *Health Phys* 13:1067-1074.
- *Morgan A, Morgan DJ, Arkell GM. 1967b. A study of the retention and subsequent metabolism of inhaled methyl iodide. In: Davies CN, ed. *Inhaled Particles and Vapours II*. Pergamon Press, Oxford, 309-321.
- *Morgan DJ, Morgan A. 1967. Studies on the retention and metabolism of inhaled methyl iodide-I: Retention of inhaled methyl iodide. *Health Phys* 13:1055-1065.
- Morgan KG, Entrikin RK, Bryant SH. 1975. Mytonia and block of chloride conductance by iodide in avian muscle. *Am J Physiol* 229(5):1155-1158.
- *Morita S, Umezaki N, Ishibashi M, et al. 1998. Determining the breast-feeding interruption schedule after administration of ^{123}I -iodide. *Ann Nucl Med* 12(5):303-306.
- Morizono T, Sikora MA. 1983. Compound action potential input-output decrement: Effect of topically applied antiseptics. *Arch Otolaryngol* 109:677-681.
- Morreale de Escobar G, Calvo R, Obregon MJ, et al. 1992. Homeostatis of brain T3 in rat fetuses and their mothers: Effects of thyroid status and iodine deficiency. *Acta Med Austriaca* 19(Suppl 1):110-116.
- Morreale de Escobar G, Obregon MJ, Calvo R, et al. 1991. Maternal thyroid hormones during pregnancy: Effects on the fetus in congenital hypothyroidism and in iodine deficiency. In: Bercu BB, Shulman DI, eds. *Advances in perinatal thyroidology*. New York, NY: Plenum Press, 133-156.
- Morreale de Escobar G, Obregon MJ, Calvo R, et al. 1993. Effects of iodine deficiency on thyroid hormone metabolism and the brain in fetal rats: The role of the maternal transfer of thyroxin. *Am J Clin Nutr Suppl*(57):280S-285S.
- Morreale de Escobar G, Obregon MJ, Escobar del Rey F. 1987. Fetal and maternal thyroid hormones. *Horm Res* 26:12-27.

9. REFERENCES

- Morrish DW, Jackson FI, Lalani ZH, et al. 1989. Cystic thyroid mass following I-131 treatment of papillary thyroid carcinoma: An unusual complication. *Clin Nucl Med* 14(12):894-896.
- *Morrison RT, Birkbeck JA, Evans TC, et al. 1963. Radioiodine uptake studies in newborn infants. *J Nucl Med* 4:162-166.
- *Morselli PL, Franco-Morselli R, Bossi L. 1980. Clinical pharmacokinetics in newborns and infants: Age-related differences and therapeutic implications. *Clin Pharmacokin* 5:485-527.
- Mortensen JD, Woolner LB, Bennett WA. 1955. Gross and microscopic findings in clinically normal thyroid glands. *J Clin Endocrinol Metab* 15:1270-1280.
- Moschizuki Y, Mowafy R, Pasternack B. 1963. Weights of human thyroids in New York City. *Health Phys* 9:1299-1301.
- Moses AM, Scheinman SJ. 1996a. The kidneys and electrolyte metabolism in hypothyroidism. In: Braverman LE, Utiger RD, eds. *Werner and Ingbar's the thyroid: A fundamental and clinical text*. Philadelphia, PA: Lippincott-Raven, 812-815.
- Moses AM, Scheinman SJ. 1996b. The kidneys and electrolyte metabolism in thyrotoxicosis. In: Braverman LE, Utiger RD, eds. *Werner and Ingbar's the thyroid: A fundamental and clinical text*. Philadelphia, PA: Lippincott-Raven, 628-631.
- Mosher BW, Winkler P, Jaffrezo J-L. 1993. Seasonal aerosol chemistry at Dye 3, Greenland. *Atmos Environ* 27A(17/18):2761-2772.
- *Mostbeck A, Galvan G, Bauer P, et al. 1998. The incidence of hyperthyroidism in Austria from 1987 to 1995 before and after an increase in salt iodization in 1990. *Eur J Nucl Med* 25(4):367-374.
- Mothersill C, Seymour C, Malone JF, et al. 1986. Survival and transformation frequency of differentiated sheep thyroid cells exposed to iodine-131 and gamma-irradiation. *Int J Radiat Biol* 49(3):524-525.
- Mothersill C, Seymour CB, Moriarty MJ, et al. 1984. Further studies on the transformation of thyroid cultures by gamma-irradiation and by iodine-131. *Int J Radiat Biol* 46(5):648.
- *Mould RF. 2000. *Chernobyl record: The definitive history of the Chernobyl catastrophe*. Philadelphia, PA: Institute of Physics Publishing.
- Mountford PJ, Coakley AJ. 1989. A review of the secretion of radioactivity in human breast milk: Data, quantitative analysis and recommendations. *Nucl Med Commun* 10:15-27.
- *Mountford PJ, O'Doherty MJ. 1999. Exposure of critical groups to nuclear medicine patients. *Appl Radiat Isot* 50:89-111.
- *Mountford PJ, Steele HR. 1995. Fetal dose estimates and the ICRP abdominal dose limit for occupational exposures of pregnant staff to technetium-99m and iodine-131 patients. *Eur J Nucl Med* 22(10):1173-1179.
- Moura EG, Ramos CF, Nascimento CCA, et al. 1987. Thyroid function in fasting rats: Variations in ¹³¹I uptake and transient decrease in peroxidase activity. *Braz J Med Biol Res* 20:407-410.
- *Movius EG, Phyllaier MM, Robbins J. 1989. Phloretin inhibits cellular uptake and nuclear receptor binding of triiodothyronine in human hep G2 hepatocarcinoma cells. *Endocrinology* 124(4):1988-1997.
- *Moxon RE. 1984. Automatic methods for the determination of total inorganic iodine and free iodide in waters. *Analyst* 109:425-430.

9. REFERENCES

- Mu L, Chengyi Q, Qidong Q, et al. 1987. Endemic goitre in central China caused by excessive iodine intake. *Lancet* 2(8553):257-259.
- Mukherjee B. 1983. Inhibition and recovery of the iodine uptake function of rat thyroids after 18 MeV proton irradiation *in vivo*. *Br J Radiol* 56:67-68.
- Murakami S, Nasu M, Fukayama H, et al. 1993. Propranolol has direct antithyroid activity: Inhibition of iodide transport in cultured thyroid follicles. *Cell Biochem Funct* 11:159-165.
- Muraki T, Tsukahara F, Fujii E, et al. 1991. Alpha₁-adrenergic stimulation of iodide organification in mouse thyroid-inhibition by protein kinase C inhibitors. *Arch Int Pharmacodyn* 314:122-132.
- *Muramatsu Y, Yoshida S. 1995. Volatilization of methyl iodide from the soil-plant system. *Atmos Environ* 29(1):21-25.
- Muramatsu Y, Sumiya M, Ohomo Y. 1986. Levels and behavior of ¹²⁷I and ¹²⁹I in the environment in Japan. In: *Spurenelement-Symposium Iodine*, 5th ed, 35-41.
- Muramatsu Y, Uchida S, Sriyotha P, et al. 1990. Some considerations on the sorption and desorption phenomena of iodide and iodate on soil. *Water Air Soil Pollut* 49:125-138.
- *Muramatsu Y, Uchida S, Sumiya M, et al. 1985. Iodine separation procedure for the determination of ¹²⁹I and ¹²⁷I in soil by neutron activation analysis. *J Radioanal Nucl Chem* 94(5):329-338.
- Murphy PC, Burson ZG. 1973. Personnel exposures due to inadequate leak test methods for ¹²⁵I sources. *Health Phys* 24:443-444.
- *Murray JL. 1969. Thyroid uptake of iodine-131 from skin exposure. *Health Phys* 17:730-731.
- *Murray RL. 1994. *Understanding radioactive waste*. 4th ed. Columbus, OH: Battelle Press.
- Mutaku JF, Many M-C, Colin I, et al. 1998. Antigoitrogenic effect of combined supplementation with dl-alpha-tocopherol, ascorbic acid and beta-carotene and of dl-alpha-tocopherol alone in the rat. *J Endocrinol* 156:551-561.
- *Myant NB. 1956. Enterohepatic circulation of thyroxine in humans.
- *Myant NB. 1958. Passage of thyroxine and tri-iodo-thyronine from mother to foetus in pregnant women. *Clin Sci* 17:75-79.
- *Myant NB, Pochin EE. 1950. The metabolism of radiothyroxine in man. *Clin Sci* 9:421-440.
- Myers DK. 1971. DNA repair in *E. coli* B/r after X-irradiation in the presence of iodide or iodoacetamide. *Int J Radiat Biol* 19(3):293-295.
- Myers DK. 1977. Repair of the double-strand breaks produced by ¹²⁵I disintegrations in the DNA of *micrococcus radiodurans*. *Curr Top Radiat Res Q* 12:369-388.
- *Myers DK, Chetty KG. 1973. Effect of radiosensitizing agents on DNA strand breaks and their rapid repair during irradiation. *Radiat Res* 53:307-314.
- Nagata C, Tagashira T, Inomata M, et al. 1971. Effect of iodine on the carcinogenicity of 3,4-benzopyrene. *Jpn J Cancer Res* 62:309-314.

9. REFERENCES

- *Nagata K, Takasu N, Akamine H, et al. 1998. Urinary iodine and thyroid antibodies in Okinawa, Yamagata, Hyogo, and Nagano, Japan: The differences in iodine intake do not affect thyroid antibody positivity. *Endocrine Journal* 45(6):797-803.
- Nagataki S, Nagayama Y. 1997. Molecular biology of the thyroid stimulating hormone receptor. In: Falk SA, ed. *Thyroid disease: Endocrinology, surgery, nuclear medicine, and radiotherapy*. Philadelphia, PA: Lippincott-Raven Publishers, 209-222.
- *Nagataki S, Yokoyama N. 1996. Other factors regulating thyroid function: Autoregulation: Effects of iodide. In: Braverman LE, Utiger RD, eds. *Werner and Ingbar's the thyroid: A fundamental and clinical text*. Philadelphia, PA: Lippincott-Raven, 241-247.
- Nagataki S, Shibata Y, Inoue S, et al. 1994. Thyroid diseases among atomic bomb survivors in Nagasaki. *JAMA* 272:364-370.
- *Nagataki S, Shizume K, Nakao K. 1967. Thyroid function in chronic excess iodide ingestion: Comparison of thyroidal absolute iodine uptake and degradation of thyroxine in euthyroid Japanese subjects. *J Clin Endocrinol* 27:638-647.
- Nagataki S, Uchimura H, Masuyama Y, et al. 1973. Is TSH-stimulated thyroid hormone release inhibited by iodide? *Endocrinology* 93:532-539.
- Nakajima H, Sasaki N, Kubimura N, et al. 1974. [Infantile hypothyroidism caused by ¹³¹I in mother's milk.] *Nippon Rinsho* 32(7):2430-2432. (Japanese)
- Nakajima T, Wang R-S, Elovaara E, et al. 1992. A comparative study on the contribution of cytochrome P450 isozymes to metabolism of benzene, toluene and trichloroethylene in rat liver. *Biochem Pharmacol* 43(2):251-257.
- *Nakamura Y, Kotani T, Ohtaki S. 1990. Transcellular iodide transport and iodination on the apical plasma membrane by monolayer porcine thyroid cells cultured on collagen-coated filters. *J Endocrinol* 126:275-281.
- Nakane Y, Honda S, Mine M, et al. 1996. The mental health of atomic bomb survivors. In: Nagataki S, Yamashita S, eds. *Nagasaki symposium radiation and human health: Proposal from Nagasaki*. Amsterdam, the Netherlands: Elsevier, 239-249.
- Nakayama S. 1970a. [Studies on hematologic changes after administration of therapeutic doses of radioactive iodine: I. Statistical studies on the occurrence of leukemia.] *Nippon Ketsueki Gakkai Zasshi* 33(5):560-577. (Japanese)
- Nakayama S. 1970b. [Studies on the hematological changes after administration of therapeutic doses of radioactive iodine.] *Nippon Ketsueki Gakkai Zasshi* 33(5):578-597. (Japanese)
- *Namba H, Yamashita S, Kimura H, et al. 1993. Evidence of thyroid volume increase in normal subjects receiving excess iodide. *J Clin Endocrinol Metab* 76(3):605-608.
- Nanping W, Guangjun Y, Zijin T. 1998. Kinetic effect of testosterone of estradiol on iodine absorption in castrating rat intestine. *Wei Sheng Yen Chiu* 27(6):396-399.
- Narra VR, Howell RW, Harapanhalli RS, et al. 1992. Radiotoxicity of some iodine-123, iodine-125 and iodine-131-labeled compounds in mouse testes: Implications for radiopharmaceutical design. *J Nucl Med* 33(12):2196-2201.
- Narra VR, Howell RW, Sastry KSR, et al. 1993. Vitamin C as a radioprotector against iodine-131 in vivo. *J Nucl Med* 34:637-640.

9. REFERENCES

Narra VR, Howell RW, Thanki KH, et al. 1991. Radiotoxicity of ^{125}I -iodoexyuridine in pre-implantation mouse embryos. *Int J Radiat Biol* 60(3):525-532.

*NAS. 1974. *Geochemistry and the environment: Volume I: The relation of selected trace elements to health and disease*. Washington, DC: National Academy of Sciences. NTIS PB80-135197.

*NAS/NRC. 1989. Report of the oversight committee. In: *Biologic markers in reproductive toxicology*. Washington, DC: National Academy of Sciences, National Research Council, National Academy Press.

Nasu M, Sugawara M. 1994. Exogenous free iodotyrosine inhibits iodide transport through the sequential intracellular events. *Eur J Endocrinol* 130:601-607.

National Research Council. 1999. *Exposure of the American people to iodine-131 from Nevada nuclear-bomb tests: Review of the National Cancer Institute*. Washington, DC: National Academy Press.

Nauman J, Wolff J. 1993. Iodide prophylaxis in Poland after the Chernobyl reactor accident: Benefits and risks. *Am J Med* 94:524-532.

*NCI. 1997. Estimated exposures and thyroid doses received by the American people from iodine-131 in fallout following Nevada atmospheric nuclear bomb tests. National Cancer Institute. <http://rex.nci.nih.gov/massmedia/Fallout/>.

*NCRP. 1977. *Protection of the thyroid gland in the event of releases of radioiodine*. Washington, DC: National Council on Radiation Protection and Measurements. NCRP Report No. 55, 19-29.

*NCRP. 1983. *Iodine-129: Evaluation of releases from nuclear power generation*. Bethesda, MD: National Council on Radiation Protection and Management. NCRP Report No. 75.

*NCRP. 1985. *General concepts for the dosimetry of internally deposited radionuclides*. National Council on Radiation Protection and Measurements. Bethesda, MD: NCRP Report No.84.

*NCRP. 1987. *Use of bioassay procedures for assessment of internal radionuclide deposition*. National Council on Radiation Protection and Measurements. Bethesda, MD: NCRP Report No. 87.

*NCRP. 1993. *Limitation of exposure to ionizing radiation*. National Council on Radiation Protection and Measurements. Report No. 116. National Council on Remediation Protection and Measurement.

NCRP. 1996. *A guide for uncertainty analysis in dose and risk assessments related to environmental contamination*. Bethesda, MD: National Council on Radiation Protection and Management. NCRP Commentary No. 14.

*NCRP. 1997. *Deposition, retention and dosimetry of inhaled radioactive substances*. National Council on Radiation Protection and Measurements. Report No. 125.

*Negretti de Bratter VE, Bratter P, Tomiak A. 1990. An automated microtechnique for selenium determination in human body fluids by flow injection hydride atomic absorption spectrometry (FI-HAAS). *J Trace Elem Electrolytes Health Dis* 4(1):41-48.

Nelson M, Phillips DIW. 1985. Seasonal variations in dietary iodine intake and thyrotoxicosis. *Hum Nutr Appl Nutr* 39A:213-216.

Nemec J, Neradilova M, Zamrazil V, et al. 1968. [Hematological changes during treatment of thyrotoxicosis and thyroid carcinoma with radioactive iodine 131.] *Cas Lek Cesk* 107(25):742-748. (Czech)

9. REFERENCES

- Nemec J, Soumar J, Zeman V, et al. 1978. Differentiated thyroid cancer following radioiodide ¹³¹I therapy of hyperthyroidism - a case report. *Oncology* 35:277-280.
- Netelenbos JC, Lips P. 1981. Hyperparathyroidism after radioactive iodine therapy. *Arch Intern Med* 141:1555-1556.
- Neu F, Rebai T, Deneff J-F, et al. 1994. Involvement of T cell immunity in the transient thyroid inflammation induced by iodide in goitrous BALB/C and nude mice. *Autoimmunity* 17:209-216.
- Neve P, Starling JR, Golstein J, et al. 1988. Effects of iodine intake on thyroid secondary lysosomes after subtotal thyroidectomy. *Endocrinology* 1988:478-486.
- Newton GL, Clawson AJ. 1974. Iodine toxicity: Physiological effects of elevated dietary iodine on pigs. *J Anim Sci* 39(5):879-884.
- Newton GL, Barrick ER, Harvey RW, et al. 1974. Iodine toxicity. Physiological effects of elevated dietary iodine on calves. *J Anim Sci* 38(2):449-455.
- Nicoloff JT, LoPresti JS. 1996. Nonthyroidal illnesses. In: Braverman LE, Utiger RD, eds. *Werner and Ingbar's the thyroid: A fundamental and clinical text*. Philadelphia, PA: Lippincott-Raven, 286-296.
- *Nikiforov YE, Fagin JA. 1998. Radiation-induced thyroid cancer in children after the Chernobyl accident. *Thyroid Today*: 21(2):1-10.
- Nilsson G. 1973. Self-limiting episodes of Jodbasedow. *Acta Endocrinol* 74:475-482.
- Nilsson M, Ericson LE. 1994. Effects of epidermal growth factor on basolateral iodide uptake and apical iodide permeability in filter-cultured thyroid epithelium. *Endocrinology* 135(4):1428-1436.
- *Nilsson M, Bjorkman U, Ekholm R, et al. 1990. Iodide transport in primary cultured thyroid follicle cells: Evidence of a TSH-regulated channel mediating iodide efflux selectively across the apical domain of the plasma membrane. *Eur J Cell Biol* 52:270-281.
- *NIOSH. 2001. Documentation for immediately dangerous to life or health concentrations. National Institute for Occupational Safety and Health. <http://www.cdc.gov/niosh/idlh/intridl4.html>.
- NIREX. 1987. Radionuclide interactions with marine sediments. Harwell, England: Nuclear Industry Radioactive Waste Executive. NTIS DE90630517.
- Nishimaki T, Furudate S. 1997. Effects of stable KI administration on iodine-125 distribution in various mouse organs. *Radioisotopes* 46(10):720-723.
- *Nishiyama H, Lukes S, Mayfield G, et al. 1980. Internal contamination of laboratory personnel by ¹³¹I. *Radiology* 137:767-771.
- *Nishizawa K, Hamada N, Sadayuki S. 1985. *In vitro* monitoring of salivary ¹²⁵I. *Health Phys* 49(2):290-295.
- *Noble B, Yoshida T, Rose NR, et al. 1976. Thyroid antibodies in spontaneous autoimmune thyroiditis in the Buffalo rat. *J Immunol* 117:1447.
- *Nobukini K, Hayakawa N, Namba R, et al. 1997. The influence of long-term treatment with providedone-iodine on thyroid function. *Dermatology* 195(Suppl 2):69-72.

9. REFERENCES

- *Noguti T, Sadaie H, Kada T. 1971. Radiosensitization with iodine compounds: III. Macromolecular synthesis and repair in *Bacillus subtilis* irradiated in the presence of iodoacetic acid, potassium iodide or potassium iodate. *Int J Radiat Biol* 19(4):305-322.
- Nolte W, Mueller R, Huefner M. 1995. [Treatment of iodine induced hyperthyroidism. Possibilities and limits of the pharmacotherapy.] *Med Klin* 90(5):246-253. (German)
- Nomura T, Katagiri H, Kitahara Y, et al. 1980. Methods of I-129 analysis for environmental monitoring. In: Ed. Radiation protection: A systematic approach to safety. Oxford, England: Pergamon Press, 935-938.
- Norfray JF, Quinn JLIII. 1974. Furosemide mediated elevations of thyroid iodide uptake in the rat. *Proc Soc Exp Biol Med* 145:286-288.
- *Norman JA, Pickford CJ, Sanders TW, Waller M. 1988. Human intake of arsenic and iodine from seaweed-based supplements and health foods available in the UK. *Food Additives and Contaminants* 5:103-109.
- Noteboom JL, Hummel WA, Broerse JJ, et al. 1997a. Protection of the infant thyroid from radioactive contamination by the administration of stable iodide. An experimental evaluation in chimpanzees. *Radiat Res* 147:698-706.
- Noteboom JL, Hummel WA, Broerse JJ, et al. 1997b. Protection of the maternal and fetal thyroid from radioactive contamination by the administration of stable iodide during pregnancy. An experimental evaluation in chimpanzees. *Radiat Res* 147:691-697.
- Noteboom JL, Hummel WA, Jansen JTM, et al. 1997c. Simulation of measurements of uptake of ¹²³I-iodide in the thyroid of fetal chimpanzees. *Radiat Res* 147:686-690.
- *Nourok DS, Gassock RJ, Solomon DH, Maxwell MH. 1964. Hypothyroidism following prolonged sodium nitroprusside therapy. *Am. J. Med. Sci.* 284:129-138.
- *Novaes M, Biancalana MM, Garcia SA, et al. 1994. Elevation of cord blood TSH concentration in newborn infants of mothers exposed to acute povidone iodine during delivery. *J Endocrinol Invest* 17:805-808.
- *NRC. 1979. A dynamic model of the global iodine cycle for the estimation of dose to the world population from releases of iodine-129 to the environment. U.S. Nuclear Regulatory Commission, Division of Safeguards, Fuel Cycle, and Environmental Research. NUREG/CR-0717.
- *NRC. 1981. On the long-term behavior of ¹²⁹I in the terrestrial environment. U.S. Nuclear Regulatory Commission, Division of Safeguards, Fuel Cycle, and Environmental Research. IAEA-SDM-257.
- NRC. 1987. Interpretative analysis of data for solute transport in the unsaturated zone. Washington, DC: U.S. Nuclear Regulatory Commission, Office of Nuclear Material Safety and Safeguards, Division of Waste Management. NUREG/CR-4737.
- *NRC. 1989. National Research Council. Iodine. In: Recommended dietary allowances. 10th edition. Washington, DC: National Academy Press, 213-217.
- *NRC. 1993. Pesticides in the diets of infants and children. National Research Council. Washington, DC: National Academy Press.
- *NRC. 1995. Radiation dose reconstruction for epidemiologic uses. Committee on Assessment of CDC Radiation Studies, National Research Council. National Academy Press, Washington, 103-111.

9. REFERENCES

- *NRC. 1997. Minimum detectable concentrations with typical radiation survey instruments for various contaminants and field conditions. Nuclear Regulatory Commission. Rockville MD: NRC; U.S. Report NUREG-1507.
- *NRC. 1999. Exposure of the American People to iodine-131 from Nevada nuclear-bomb tests. National Research Council. National Academy Press, Washington, DC.
- *NRC. 2001a. Index of radioisotopes: Iodine. U.S. Nuclear Regulatory Commission. <http://www.nrc.gov/>.
- *NRC. 2001b. Byproduct material list. U.S. Nuclear Regulatory Commission. <http://www.nrc.gov/>.
- *NRC. 2001c. Packaging and transportation of radioactive material. Determination of A1 and A2. U.S. Nuclear Regulatory Commission. Code of Federal Regulations. 10 CFR 71, Appendix A. <http://ecfrback.access.gpo.gov/otcqi/cfr/otfilter.cgi...nd&QUERY=89865&RGN=APPCT&SUBSET=SUBSET&FROM=1&ITEM=1>. May 16, 2001.
- *NRC. 2001d. Waste classification. U.S. Nuclear Regulatory Commission. Code of Federal Regulations. 10 CFR 61.55. <http://ecfrback.access.gpo.gov/otcqi/cfr...7&RGN=BSECCT&SUBSET=SUBSET&FROM=1&ITEM=1>. May 16, 2001.
- *NRCC. 1980. National Research Council of Canada. Radioactivity in the Canadian environment. Ottawa, Ontario. NTIS DE82701242.
- Nygaard B, Faber J, Veje A, et al. 1995a. Appearance of Graves'-like disease after radioiodine therapy for toxic as well as non-toxic multinodular goitre. *Clin Endocrinol* 43:129-131.
- Nygaard B, Faber J, Veje A, et al. 1999. Transition of nodular toxic goiter to autoimmune hyperthyroidism triggered by ¹³¹I therapy. *Thyroid* 9(5):477-481.
- Nygaard B, Hegedus L, Gervil M, et al. 1993. Radioiodine treatment of multinodular non-toxic goitre. *Br Med J* 307:828-832.
- Nygaard B, Hegedus L, Gervil M, et al. 1995b. Influence of compensated radioiodine therapy on thyroid volume and incidence of hypothyroidism in Graves' disease. *J Int Med* 238:491-497.
- Nygaard B, Knudsen JH, Hegedus L, et al. 1997. Thyrotropin receptor antibodies and Graves' disease, a side-effect of ¹³¹I treatment in patients with nontoxic goiter. *J Clin Endocrinol Metab* 82(9):2926-2930.
- Ober KP, Hennessy JF. 1981. Jodbasedow and thyrotoxic periodic paralysis. *Arch Intern Med* 141:1225-1227.
- Oberhausen E. 1990. Side effects of iodine-containing chemical. In: Rubery E, Smales E, eds. *Iodine prophylaxis following nuclear accidents*. Oxford, UK: Pergamon Press, 93-100.
- Oberhausen E. 1991. Risk of thyroid carcinoma after iodine-131 treatment. *EUR* 12556:111-144.
- O'Connell MEA, Flower MA, Hinton PJ, et al. 1993. Radiation dose assessment in radioiodine therapy. Dose-response relationships in differentiated thyroid carcinoma using quantitative scanning and PET. *Radiother Oncol* 28:16-26.
- *Oddie TH, Fisher DA. 1967. Mean euthyroid 24-hour radioiodine uptake as a characteristic of different patient populations. *J Clin Endocrinol Metab* 27:11-14.

9. REFERENCES

- Oddie TH, Fisher DA, Criner G. 1966. Lag time for oral radioiodide tracer doses. *J Clin Endocrinol Metab* 26(5):581-582.
- Oddie TH, Fisher DA, Criner G. 1996. Lag time for oral radioiodide tracer doses. *J Clin Endocrinol* 26:581-582.
- Oddie TH, Fisher DA, Long JM. 1964. Factors affecting the estimation of iodine entering the normal thyroid gland using short-term clearance studies. *J Clin Endocrinol* 24:924-933.
- *Oddie TH, Fisher DA, McConahey WM, et al. 1970. Iodine intake in the United States: A reassessment. *J Clin Endocrinol* 30:659-665.
- *Oddie TH, Meschan I, Wortham J. 1955. Thyroid function assay with radioiodine. I. Physical basis of study of early phase of iodine metabolism and iodine uptake. *J Clin Invest* 34:95-105.
- *Oddie TH, Myhill J, Pirnique FG, et al. 1968a. Effect of age and sex on the radioiodine uptake in euthyroid subjects. *J Clin Endocrinol* 28:776-782.
- Oddie TH, Pirnique FG, Fisher DA, et al. 1968b. Geographic variation of radioiodine uptake in euthyroid subjects. *J Clin Endocrinol* 28:761-775.
- *Oddie TJ, Thomas ID, Rundle FF, et al. 1960. Diagnostic limits for thyroidal radioiodine uptake rates. *J Clin Endocrinol Metab* 20:389-400.
- O'Doherty MJ, Coakley AJ. 1998. Drug therapy alternatives in the treatment of thyroid cancer. *Drugs* 55:801-812.
- O'Doherty MJ, Kettle AG, Eustance CNP, et al. 1993. Radiation dose rates from adult patients receiving ¹³¹I therapy for thyrotoxicosis. *Nucl Med Commun* 14:160-168.
- O'Doherty MJ, McElhatton PR, Thomas SHL. 1999. Treating thyrotoxicosis in pregnant or potentially pregnant women: The risk to the fetus is very low. *Br Med J* 318:5-6.
- O'Donnell AL, Spaulding SW. 1997. Hyperthyroidism: Systemic effects and differential diagnosis. In: Falk SA, ed. *Thyroid disease: Endocrinology, surgery, nuclear medicine, and radiotherapy*. Philadelphia, PA: Lippincott-Raven Publishers, 241-252.
- O'Donnell E, Duckart EC, Schulz RK. 1993. Anion retention in soil: Possible application to reduce migration of buried technetium and iodine-development of a field test. In: *Waste management '93: Working towards a cleaner environment: Waste processing, transportation, storage and disposal, technical programs and public education: Technology and programs for radioactive waste management and environmental restoration*. Tuscon, AZ: Arizona Board of Regents, 1541-1551.
- O'Donoghue JA, Wheldon TE. 1996. Targeted radiotherapy using Auger electron emitters. *Phys Med Biol* 41:1973-1992.
- *Ogborn RE, Waggener RE, VanHove E. 1960. Radioactive-iodine concentration in thyroid glands of newborn infants. *Pediatrics* :771-776.
- Ogris E. 1997. [Exposure with J-131 during pregnancy: Significance for mother and child.] *Acta Med Austriaca* 24:150-153. (German)
- O'Hare NJ, Gilligan P, Murphy D, et al. 1997. Estimation of foetal brain dose from I-131 in the foetal thyroid. *Phys Med Biol* 42:1717-1726.

9. REFERENCES

- O'Hare NJ, Murphy D, Malone JF. 1998. Thyroid dosimetry of adult European populations. *Br J Radiol* 71:535-543.
- Ohmomo Y, Nakamura Y, Honma Y, et al. 1978. [Studies on the estimation of radiation dose to thyroid gland through foods contaminated by gaseous radioactive iodine.] Hoshasen Igaku Sogo Kenkyusho, [Tech Rep] NIRS-R 8:29-35. (Japanese)
- *Ohno S. 1971. Determination of iodine and bromine in biological materials by neutron activation analysis. *Analyst* 96:423-426.
- *Ohno M, Zannini M, Levy O, et al. 1999. The paired-domain transcription factor Pax8 binds to the upstream enhancer of the rat sodium/iodide symporter gene and participates in both thyroid-specific and cyclic-AMP-dependent transcription. *Mol Cell Biol* 19(3):2051-2060.
- Ohshima M, Ward JM. 1986. Dietary iodine deficiency as a tumor promoter and carcinogen in male F344/NCr rats. *Cancer Res* 46:877-883.
- Ohtake M, Onaya T, Sato A, et al. 1973. Studies on the mechanism of inhibitory action of excess iodide on thyroid hormone secretion. *Proc Soc Exp Biol Med* 144(2):538-543.
- Ohtaki S, Nakagawa H, Nakamura M, et al. 1996. Thyroid peroxidase: Experimental and clinical integration. *Endocr J (Tokyo)* 43(1):1-14.
- *Okano M. 1989. Irritant contact dermatitis caused by the povidone-iodine. *J Am Acad Dermatol* 20(5):860.
- Okuno Y, Kunimatsu T, Tanahashi K, et al. 1996. Effect of simultaneous treatment of large amounts of vitamin A and thiourea on thyroidal iodine uptake and organification in rats. *J Toxicol Pathol* 9:385-390.
- *Oliner L, Kohlenbrener RM, Fields T, et al. 1957. Thyroid function studies in children: Normal values for thyroidal I¹³¹ uptake and PBI¹³¹ levels up to the age of 18. *J Clin Endocrinol Metab* 17:61-75.
- Olinescu R, Bartoc R, Militaru M, et al. 1992. The changes of peroxides and total antioxidant in the plasma of patients who received ¹³¹I therapeutically. *Rev Roum Med Med Interne* 30(2):113-117.
- Oliver LL, Ballard RV, Manuel OK. 1982a. Iodine-129 in Missouri rain and milk. *J Radioanal Chem* 68(1-2):233-244.
- *Oliver LL, Ballard RV, Manuel OK. 1982b. ¹²⁹I in Missouri thyroids. *Health Phys* 42:425-432.
- Olsen KJ, Ehlers N, Schonheyder F. 1979. Studies on the handling of retinotoxic doses of iodate in rabbits. *Acta Pharmacol Toxicol (Copenh)* 44:241-250.
- Olson WG, Stevens JB, Anderson J, et al. 1984. Iodine toxicosis in six herds of dairy cattle. *J Am Vet Med Assoc* 184(2):179-181.
- Olurin E. 1983. Epidemiology of cancer of the thyroid gland in Ibadan (Nigeria). *Acta Endocrinol Suppl* 252:16.
- Ondov JM, Choquette CE, Zoller WH, et al. 1989. Atmospheric behavior of trace elements on particles emitted from a coal-fired power plant. *Atmos Environ* 23(10):2193-2204.
- *O'Neill B, Magnolato D, Semenza G. 1987. The electrogenic, Na⁺-dependent I⁻ transport system in plasma membrane vesicles from thyroid glands. *Biochim Biophys Acta* 896:263-274.

9. REFERENCES

- *Oppenheimer JH, Schwartz HL. 1985. Stereospecific transport of triiodothyronine from plasma to cytosol and from cytosol to nucleus in rat liver, kidney, brain, and heart. *J Clin Invest* 75:147-154.
- Oppenheimer JH, Schwartz HL, Strait KA. 1996. The molecular basis of thyroid hormone actions. In: Braverman LE, Utiger RD, eds. *Werner and Ingbar's the thyroid: A fundamental and clinical text*. Philadelphia, PA: Lippincott-Raven, 162-184.
- Orazio AF, Dunkleberger JD. 1988. New York's development of low-level radioactive waste disposal capability. In: ed. *Proceedings of the ACPA annual meeting*. Air Pollution and Control Association, 88-23.10.
- Orme MCL, Connolly ME. 1971. Hypoparathyroidism after iodine-131 treatment of thyrotoxicosis. *Ann Intern Med* 75(1):136-137.
- Orr MM, Tamarind DL, Cook J, et al. 1975. Chronic lesions of rabbit bowel due to contact with antiseptic skin preparation. *Gut* 16(5):401.
- Oscarson DW, Hume HB, Sawatsky NG, et al. 1992. Diffusion of iodide in compacted bentonite. *Soil Sci Soc Am J* 56:1400-1406.
- *OSHA. 2001a. Air contaminants. Shipyards. Occupational Safety and Health Administration. U.S. Department of Labor. Code of Federal Regulations. 29 CFR 1915.1000, Table Z. http://www.osha-slc.gov/OshStd_data/1915_1000.html. March 26, 2001.
- *OSHA. 2001b. Limits for air contaminants. Occupational Safety and Health Administration, U.S. Department of Labor. http://www.osha-slc.gov/OshStd_data/1910_1000_TABLE_Z-1.html, February 22, 2001.
- *OSHA. 2001c. Threshold limit values of airborne contaminants for construction. Occupational Safety and Health Administration. U.S. Department of Labor. Code of Federal Regulations. 29 CFR 1926.55, Appendix A. http://www.osha-slc.gov/OshStd_data/1926_0055_APP_A.html. March 26, 2001.
- Osmanagaoglu K, Foulon W. 1998. Concerns about risks of irradiation during pregnancy. *J Nucl Med* 39(12):2194-2195.
- OTA. 1990. Neurotoxicity: Identifying and controlling poisons of the nervous system. Washington, DC: Office of Technology Assessment. OTA-BA-438.
- Othman S, Phillips DIW, Lazarus JH, et al. 1992. Iodine metabolism in postpartum thyroiditis. *Thyroid* 2(2):107-111.
- Ott RA, Hofmann C, Oslapas R, et al. 1987. Radiiodine sensitivity of parafollicular C cells in aged Long-Evans rats. *Surgery* 102(6):1043-1048.
- *Owen GM, Brozek J. 1966. Influence of age, sex and nutrition on body composition during childhood and adolescence. In: Falkner F, ed. *Human development*. Philadelphia, PA: WB Saunders, 222-238.
- Ozakay H, Unak P, Biber Z, et al. 1998. Determination of iodide in drinking water by isotope dilution analysis. *J Radioanal Nucl Chem* 230(1-2):231-233.
- Ozaki O, Ito K, Mimura T, et al. 1994. Thyroid carcinoma after radioactive iodine therapy for Graves' disease. *World J Surg* 18:518-521.
- Ozawa Y, Migita M, Watanabe T, et al. 1994. Development of Graves' ophthalmopathy and uveitis after radioiodine therapy for Graves' disease in a patient with HTLV-I associated myelopathy (HAM). *Intern Med* 33:564-568.

9. REFERENCES

- *Pacini F, Gasperi M, Fugazzola L, et al. 1994. Testicular function in patients with differentiated thyroid carcinoma treated with radioiodine. *J Nucl Med* 35(9):1418-1422.
- *Pacini F, Vorontsova T, Demidchik EP, et al. 1997. Post-Chernobyl thyroid carcinoma in Belarus children and adolescents: Comparison with naturally occurring thyroid carcinoma in Italy and France. *J Clin Endocrinol Metab* 82(11):3563-3569.
- Pacyna JM. 1995. The origin of Arctic air pollutants: Lessons learned and future research. *Sci Total Environ* 160/161:39-53.
- Pahjua DN, Rajan MGR, Borkar AV, et al. 1993. Potassium iodate and its comparison to potassium iodide as a blocker of ¹³¹I uptake by the thyroid in rats. *Health Phys* 65(5):545-549.
- Pahuja DN, Rajan MGR, Chaudhari PR, et al. 1997. On thyroid protection against radioiodine. *Radiat Prot Environ* 20(2):93-95.
- Paindakhel SM, Begum N, Shah H, et al. 1980. Iodine induced thyrotoxicosis-case reports and review of literature. *JPMA JPakMedAssoc* 30(5):122-124.
- Painter RB, Young BR. 1977. Anomalous effects of ¹²⁵I after its incorporation into mammalian cell DNA. *Curr Top Radiat Res Q* 12:472-479.
- *Palmer HE, Branson BM, Cohn SH, et al. 1976. Standard field methods for determining ¹³¹I *in vivo*. *Health Phys* 30:113.
- Palms JM, Veluri VR, Boone FW. 1975. The environmental impact ¹²⁹I released by a nuclear fuel-reprocessing plant. *Nuclear Safety* 16(5):593-602.
- Panariti E. 1995. The secretion of radioactive iodine (¹³¹I) into the milk of small ruminants following their experimental contamination. *DtschTieraerztlWochenshr* 102:198-200.
- Panday CS, Kochupillai N. 1982. Iodine prophylaxis and endemic goitre. *Indian J Pediatr* 49:819-822.
- Papa CM. 1976. Acne and hidden iodides [Letter]. *Arch Dermatol* 112:555-556.
- Papadopoulos D, Thomas P. 1977. [Ratio of the dose factors of the isotopes of iodine.] *Kernforschungszentrum Karlsruhe, [Ber.], KFK 2544, 14 pp. (German)*
- Papadopoulos I, Schnapka C, Kelami A. 1986. Examinations of polyvidone-iodine as an irrigation solution for spermatic duct occlusions. *Andrologia* 18(6):649-658.
- Papas A, Ingalls JR, Campbell LD. 1979. Studies on the effects of rapeseed meal on thyroid status of cattle, glucosinolate and iodine content of milk and other parameters. *J Nutr* 109:1129-1139.
- Park YK, Harland BF, Vanderveen JE, et al. 1981. Estimation of dietary iodine intake of Americans in recent years. *J Am Diet Assoc* 79:17-24.
- *Parmentier M, Libert F, Maenhaut C, et al. 1989. Molecular cloning of the thyrotropin receptor. *Science* 246:1620-1622.
- Parrott MW, Johnston ME, Durbin PW. 1960. The effects of thyroid and parathyroid deficiency on reproduction in the rat. *Endocrinology* 67:467-483.
- *Paschke R, Vogg M, Winter J, et al. 1994. The influence of iodine on the intensity of the intrathyroidal autoimmune process in Graves' disease. *Autoimmunity* 17:319-325.

9. REFERENCES

- *Pastan I. 1957. Absorption and secretion of iodide by the intestine of the rat. *Endocrinol.* 61:93-97.
- Pasternak FP, Socolow EL, Ingbar SH. 1969. Synergistic interaction of phenazone and iodide on thyroid hormone biosynthesis in the rat. *Endocrinology* 84:769-777.
- Patten JR, Whitford GM, Stringer GI, et al. 1978. Oral absorption of radioactive fluoride and iodide in rats. *Arch Oral Biol* 23:215-217.
- *Patton GW, Cooper AT. 1993. Air pathway effects of nuclear materials production at the Hanford site, 1983 to 1992. Battelle Pacific Northwest Laboratories, Richland WA. NTIS:DE94002708.
- *Paul T, Meyers B, Witorsch RJ, et al. 1988. The effect of small increases in dietary iodine on thyroid function in euthyroid subjects. *Metabolism* 37(2):121-124.
- Pavlovic-Hournac M, Delbauffe D. 1977. Discontinuity of thyroid gland response to hormonal stimulation: Effect of TSH and cAMP on iodide organification. *Mol Cell Endocrinol* 8:157-173.
- Peden NR, Hart IR. 1984. The early development of transient and permanent hypothyroidism following radioiodine therapy for hyperthyroid Graves' disease. *Can Med Assoc J* 130:1141-1144.
- *Pedersen KM, Laurberg P, Iverson E, et al. 1993. Amelioration of some pregnancy-associated variations in thyroid function by iodine supplementation. *J Clin Endocrinol Metab* 77(4):1078-1083.
- *Pekary AE, Hershman JM, Berg L. 1998. Tumor necrosis factor, ceramide, transforming growth factor-beta₁, and aging reduce Na⁺/I⁻ symporter messenger ribonucleic acid levels in FRTL-5 cells. *Endocrinology* 139(2):703-712.
- *Pena-Penabad C, De Unamuno P, Garcis-Silva J, et al. 1993. Vegetating iododerma and conjunctival involvement. *EJD Eur J Dermatol* 3:671-673.
- Pendergrast WJ, Milmore BK, Marcus SC. 1961. Thyroid cancer and thyrotoxicosis in the United States: Their relation to endemic goiter. *J Chronic Dis* 13:22-38.
- *Pendleton RC, Mays CW, Lloyd RD. 1963. Differential accumulation of ¹³¹I from local fallout in people and milk. *Health Phys.* 19:1253-1262.
- *Pendleton RC, Lloyd RD, Mays CW, Lloyd RD. 1963. Iodine-131 in Utah during July and August 1962. *Science* 141(3581):640-642.
- *Penfold JL, Pearson CC, Savage JP, et al. 1978. Iodide induced goitre and hypothyroidism in infancy and childhood. *Aust Paediatr J* 14:69-73.
- Pennington JS, Martin FIR. 1967. Hypothyroidism following treatment of thyrotoxicosis with radioiodine. *Med J Aust* 2(14):641-643.
- *Pennington JAT. 1988. Chapter 4. Iodine. In: Smith KT, ed. *Handbook on Trace Minerals in Foods: Their Relationship to Health and Nutrition*. New York: Marcel Dekker.
- *Pennington JAT. 1990a. Iodine concentrations in US milk: Variation due to time, season, and region. *J Dairy Sci* 73:3421-3427.
- *Pennington JAT. 1990b. A review of iodine toxicity reports. *J Am Diet Assoc* 90:1571-1581.
- *Pennington JAT, Young BE, Wilson DB, et al. 1986. Mineral content of foods and total diets: The selected minerals in foods survey, 1982-1984. *J Am Diet Assoc* 86:876-891.

9. REFERENCES

- *Pennington JAT, Wilson, Harland BF, et al. 1984. Selected minerals in foods surveys, 1974 to 1981/82. *J Amer Diet Assoc* 84:771-780.
- Pepe F, Calvo G, Chirico E, et al. 1993. [Obstetric and perinatal implications of thyroid pathology in pregnancy. Review of the literature.] *Minerva Ginecol* 45(11):565-585. (Italian)
- *Pereira A, Braekman JC, Dumont JE, et al. 1990. Identification of a major iodolipid form horse thyroid gland as 2-iodohexadecanol. *J Biol Chem* 271:23006.
- *Perkins 1963. Physical and chemical form of I^{131} in fallout. *Health Physics* 9:1113.
- Perlman JA, Sternthal PM. 1983. Effect of I^{131} on the anemia of hyperthyroidism. *J Chronic Dis* 36(5):405-412.
- *Perrault G, Thieblemont P, Pasquier C, et al. 1967. Cinétique du passage du radioide soluble a travers les epitheliums respiratoires, apres inhalation. *Health Phys* 13:707-718.
- *Perret J, Ludgate M, Libert F, et al. 1990. Stable expression of the human TSH receptor in CHO cells and characterization of differentially expressing clones. *Biochem Biophys Res Commun* 171(3):1044-1050.
- *Pesavento M, Profumo A. 1985. General procedure for the determination of trace amounts of iodine in natural water samples of unknown composition by spectrophotometric titration. *Analyst* 110:181-183.
- Peter HJ, Burgi U, Gerber H. 1996. Pathogenesis of nontoxic diffuse and nodular goiter. In: Braverman LE, Utiger RD, eds. *Werner and Ingbar's the thyroid: A fundamental and clinical text*. Philadelphia, PA: Lippincott-Raven, 890-895.
- Peters J, O'Reilly S, Barragry JM. 1993. Anaplastic carcinoma of the thyroid following radio-iodine therapy. *Isr J Med Sci* 162(1):3-4.
- Petersen RB, Goren H, Cohen M, et al. 1997. Transthyretin amyloidosis: A new mutation associated with dementia. *Ann Neurol* 41:307-313.
- *Petrova A, Gnedko T, Maistrova I, et al. 1997. Morbidity in a large cohort study of children born to mothers exposed to radiation from Chernobyl. *Stem Cells* 15(Suppl 2):141-150.
- *Pettersson B, Adami H-O, Wilander E, et al. 1991. Trends in thyroid cancer incidence in Sweden, 1958-1981, by histopathologic type. *Indian J Cancer* 48:28-33.
- *Pettersson B, Coleman MP, Ron E, et al. 1996. Iodine supplementation in Sweden and regional trends in thyroid cancer incidence by histopathologic type. *Indian J Cancer* 65:13-19.
- Petty CS, DiBenedetto RL. 1957. Goiter of the newborn. *N Engl J Med* 256:1103-1105.
- Phaneuf D, Cote I, Dumas P, et al. 1999. Evaluation of the contamination of marine algae (seaweed) from the St. Lawrence river and likely to be consumed by humans. *Environ Res* 80:S175-S182.
- Pharoah POD. 1996. 'Iodine and brain development' [Letter]. *Dev Med Child Neurol* 38:278-282.
- Pharoah POD, Connolly KJ. 1991. Effects of maternal iodine supplementation during pregnancy. *Arch Dis Child* 66(1):145-147.
- Pharoah POD, Connolly KJ. 1995. Iodine and brain development. *Dev Med Child Neurol* 37(8):744-748.

9. REFERENCES

- Pharoah POD, Butfield IH, Hetzel BS. 1971. Neurological damage to the fetus resulting from severe iodine deficiency during pregnancy. *Lancet* 1:308-310.
- Pharoah POD, Butfield IH, Hetzel BS. 1972. The effect of iodine prophylaxis on the incidence of endemic cretinism. *Adv Exp Med Biol* 30:201-221.
- *Phelps E, Wu P, Bretz J, et al. 2000. Thyroid cell apoptosis. *Autoimmune Thyroid Disease* 29(2):375-388.
- Phillips DIW, Lazarus JH, Hall R. 1988a. Iodine metabolism and the thyroid. *J Endocrinol* 119:361-363.
- Phillips DIW, Nelson M, Barker DJP, et al. 1988b. Iodine in milk and the incidence of thyrotoxicosis in England. *Clin Endocrinol* 28:61-66.
- Pic P, Michel-Bechet M, Bottini J. 1984. TSH stimulation of iodine organification in early foetal rat thyroid *in vitro*. *Biol Cell* 51:105-108.
- Piermattei A, Arcovito G, Azario L. 1990. Assessment of ¹²⁵I clinical dose specification from recent dose rate evaluations. *Med Physics* 17(5):934-936.
- Piers DA, Janssen S, Oosten HR, et al. 1988. Mediastinal hemorrhage after treatment of thyrotoxicosis using radioiodine. *Clin Nucl Med* 13(8):574-576.
- Pietrzyk Z, Michalkiewicz M, Huffman LJ, et al. 1992. Vasoactive intestinal peptide enhances thyroidal iodide uptake during dietary iodine deficiency. *Endocr Res* 18(3):213-228.
- Pietsch J, Meakins JL. 1976. Complications of povidone-iodine absorption in topically treated burn patients. *Lancet* 1(7954):280-282.
- Pilch BZ, Kahn CR, Ketcham AS, et al. 1973. Thyroid cancer after radioactive iodine diagnostic procedures in childhood. *Pediatrics* 51(5):898-902.
- Piletta P, Rieckhoff L, Saurat JH. 1994. Triggering of bullous pemphigoid by iodine [Letter]. *Br J Dermatol* 131(1):145-147.
- Pinchera A, Bartalena L, Marcocci C. 1995. Radioiodine may be bad for Graves' ophthalmopathy, but... *J Clin Endocrinol Metab* 80(2):342-345.
- Pinchera A, Fenzi GF, Mariotti S, et al. 1990. Iodine and autoimmune thyroid disease. In: Rubery E, Smales E, eds. *Iodine prophylaxis following nuclear accidents*. Oxford, UK: Pergamon Press, 39-44.
- Pisarev MA. 1985. Thyroid autoregulation. *J Endocrinol Invest* 8:475-484.
- Pisarev MA, Aiello LO. 1976. Studies on the mechanism of action of potassium iodide on thyroid protein biosynthesis. *Acta Endocrinol* 82:298-305.
- Pisarev MA, Altschuler N. 1973. Action of potassium iodide on thyroid acid protease. *Acta Endocrinol* 74:703-710.
- *Pisarev MA, Gartner R. 2000. Autoregulatory actions of iodine. In: Braverman LE, Utiger RD, eds. *Werner and Ingbar's the thyroid: A fundamental and clinical text*. 8th ed. Philadelphia, PA: Lippincott-Williams and Wilkins, 85-90.
- Pisarev MA, Itoiz ME. 1972. Action of KI on stimulated thyroid protein biosynthesis. *Endocrinology* 90:1409-1412.

9. REFERENCES

Pisarev MA, Aiello LO, Kleiman de Pisarev DL. 1976. Action of KI, thyroxine and cyclic AMP on [³H]uridine incorporation into the RNA of thyroid slices. *Acta Endocrinol* 83:313-320.

Pisarev MA, DeGroot LJ, Hati R. 1971. KI and imidazole inhibition of TSH and c-AMP induced thyroidal iodine secretion. *Endocrinology* 88:1217-1221.

Pitslavas V, Smerdely P, Li M, et al. 1997. Amiodarone induces a different pattern of ultrastructural change in the thyroid to iodine excess alone in both the BB/W rat and the Wistar rat. *Eur J Endocrinol* 137:89-98.

*Pittman CS, Buck ME, Chambers JB. 1972. Urinary metabolites of ¹⁴C-labeled thyroxine in man. *J Clin Invest* 51:1759-1766.

*Pittman CS, Shimizu T, Burger A, et al. 1980. The nondeiodinative pathways of thyroxine metabolism: 3,5,3',5'-tetraiodothyroacetic acid turnover in normal and fasting human subjects. *J Clin Endocrinol Metab* 50(4):712-716.

*Pittman JA, Dailey GE, Beschi RJ. 1969. Changing normal values for thyroidal radioiodine uptake. *N Engl J Med* 280(26):1431-1434.

*Plato P, Jacobson AP, Homann S. 1976. *In vivo* thyroid monitoring for iodine-131 in the environment. *Int J Appl Radiat Isot* 27:539-545.

Ploth DW, Fitz A, Schnetzler D, et al. 1978. Thyroglobulin-anti-thyroglobulin immune complex glomerulonephritis complicating radioiodine therapy. *Clin Immunol Immunopathol* 9:327-334.

Pochin EE. 1952. The iodine uptake of the human thyroid throughout the menstrual cycle and in pregnancy. *Clin Sci* 11:441-445.

*Pohlenz J, Refetoff S. 1999. Mutations in the sodium/iodide symporter (NIS) gene as a cause for iodide transport defects and congenital hypothyroidism. *Biochimie* 81:469-476.

*Pohlenz J, Medeiros-Neto G, Gross JL, et al. 1997. Hypothyroidism in a Brazilian kindred due to iodide trapping defect caused by a homozygous mutation in the sodium/iodide symporter gene. *Biochem Biophys Res Commun* 240:488-491.

Poliak AL. 1988a. [Effect of iodine vapors on the oral mucosa of workers in iodine manufacture.] *Gig Tr Prof Zabol* 7:26-28. (Russian)

Poliak AL. 1988b. [Experimental data on the effect of iodine vapors on the tissues and organs of the oral cavity.] *Gig Tr Prof Zabol* 9:48-49. (Russian)

*Pomroy C. 1979. Surveys of lab technicians for ¹²⁵I thyroid burdens. *Occup Health Safe* 48(4):40-42.

Porri F, Vervloet D. 1994. [Reactions to iodinated contrast media.] *Allerg Immunol (Paris)* 26(10):374-376. (French)

Porterfield SP, Hendrich CE. 1991. The thyroidectomized pregnant rat-an animal model to study fetal effects of maternal hypothyroidism. In: Bercu BB, Shulman DI, eds. *Advances in perinatal thyroidology*. New York, NY: Plenum Press, 107-132.

Porterfield SP, Hendrich CE. 1993. The role of thyroid hormones in prenatal and neonatal neurological development-current perspectives. *Endocrine Rev* 14(1):94-106.

Postellon DC, Aronow R. 1982. Iodine in mother's milk. *JAMA* 247(4):463.

9. REFERENCES

- *Poston TM. 1986. Literature review of the concentration ratios of selected radioisotopes in freshwater and marine fish. Battelle Pacific Northwest Labs Report No. DE86-015820 (NTIS/DE86015820), 1-21, 82-84, 243-272.
- Potter GD, Taurog A, Chaikoff IL. 1956. The I^{131} -irradiated rat thyroid: Its altered response to various stimuli and the changes induced in its iodine metabolism. *Endocrinology* 59(1):12-26.
- Pottern LM, Kaplan MM, Larsen PR, et al. 1990. Thyroid nodularity after childhood irradiation for lymphoid hyperplasia: A comparison of questionnaire and clinical findings. *J Clin Epidemiol* 43(5):449-460.
- Poverennyi AM, Shinkarkina AP, Vinogradova YE, et al. 1996. [Probable consequence of damage by radioactive iodine to thyroid gland in the period of the Chernobyl accident.] *Radiats Biol Radioecol* 36(4):632-640. (Russian)
- Powell E. 1978. Iodine and acetone-containing plastic spray dressings. *Br Med J* 2(6150):1500.
- *Prager EM, Gardner RE. 1979. Iatrogenic hypothyroidism from topical iodine-containing medications. *West J Med* 130(6):553-555.
- Pregliasco L, Bocanera L, Chester H, et al. 1991. Iodide inhibits thyroglobulin synthesis. In: Gordon A, Gross J, Hennemann G, eds. *Progress in thyroid research*. Rotterdam, the Netherlands: Balkema, 491-494.
- Prenger KB, Poeschmann PH, Smits PHJ, et al. 1984. Massive mediastinal hemorrhage following treatment of hyperthyroidism with radioactive iodine. *Thorac Cardiovasc Surg* 32:122-123.
- Prentice RL, Kato H, Yoshimoto K, et al. 1982. Radiation exposure and thyroid cancer incidence among Hiroshima and Nagasaki residents. *Natl Cancer Inst Monogr* 62:207-212.
- Press OW, Shan D, Howell-Clark J, et al. 1996. Comparative metabolism and retention of iodine-125, yttrium-90, and indium-111 radioimmunoconjugates by cancer cells. *Cancer Res* 56:2123-2129.
- Preston RL. 1994. Serum inorganic iodine dynamics in cattle following a single oral dose of several iodine sources. *FASEB J* 8(4-5):A431.
- Preuschhof L, Keller F, Bogner U, et al. 1991. Plasma exchange and hemoperfusion in iodine-induced thyrotoxicosis. *Blood Purif* 9:164-168.
- *Prichard HM, Gesell TF, Davis E. 1981. Iodine-131 levels in sludge and treated municipal waste waters near a large medical complex. *AJPH* 71:47-52.
- Primack A. 1971. Potassium iodide interaction with cyclophosphamide in mice. *Proc Soc Exp Biol Med* 137(2):604-606.
- Prinz RA, Oslapas R, Hofmann C, et al. 1982. Long-term effect of radiation on thyroid function and tumor formation. *J Surg Res* 32:329-337.
- Pyati SP, Ramamurthy RS, Krauss MT, et al. 1977. Absorption of iodine in the neonate following topical use of povidone iodine. *J Pediatr* 91(5):825-828.
- *Que Hee SS, Boyle JR. 1988. Simultaneous multielemental analysis of some environmental and biological samples by inductively coupled plasma atomic emission spectrometry. *Anal Chem* 60:1033-1042.

9. REFERENCES

- *Quimby EH, Werner SC, Schmidt C. 1950. Influence of age, sex, and season upon radioiodine uptake by the human thyroid. *Proc Soc Exp Biol Med* 75:537-543.
- Radlinger G, Heumann KG. 1998. Iodine determination in food samples using inductively coupled plasma isotope dilution mass spectrometry. *Anal Chem* 70:2221-2224.
- Radvila A, Roost R, Burgi H, et al. 1976. Inhibition of thyroglobulin biosynthesis and degradation by excess iodide. Synergism with lithium. *Acta Endocrinol* 81:495-506.
- Rae JE, Malik SA. 1996. The determination of iodine in geochemical samples: The use of pyrohydrolytic decomposition. *Chemosphere* 33(11):2121-2128.
- *Raghavendran KV, Satbhai PD, Abhyankar B, et al. 1978. Long-term retention studies of ^{131}I and ^{137}Cs and ^{60}Co in Indian workers. *Health Phys* 34:185-188.
- *Rajatanavin R, Safran M, Stoller WA, et al. 1984. Five patients with iodine-induced hyperthyroidism. *Am J Med* 77:378-384.
- Rajendran VM, Geibel J, Binder HJ. 1995. Chloride-dependent Na-H exchange. *J Biol Chem* 270(19):11051-11054.
- *Rallison ML. 1996. Thyroid neoplasia from fallout near the Nevada test site. In: Nagasaki S, Yamashita S, eds. *Nagasaki symposium radiation and human health: Proposal from Nagasaki*. Amsterdam, the Netherlands: Elsevier, 147-154.
- *Rallison ML, Dobyns BM, Keating FR, et al. 1974. Thyroid disease in children: A survey of subjects potentially exposed to fallout radiation. *Am J Med* 56:457-463.
- Rallison ML, Dobyns BM, Keating R, et al. 1975. Thyroid nodularity in children. *JAMA* 233(10):1069-1072.
- *Rallison ML, Lotz TM, Bishop M, et al. 1990. Cohort study of thyroid disease near the Nevada test site: A preliminary report. *Health Phys* 59(5):739-746.
- *Ramirez MJ, Surralles J, Galofre P, et al. 1997. Radioactive iodine induces clastogenic and age-dependent aneuploidic effects in lymphocytes of thyroid cancer patients as revealed by interphase FISH. *Mutagenesis* 12(6):449-455.
- Ramirez MJ, Surralles J, Galofre P, et al. 1999. FISH analysis of 1cen-1q12 breakage, chromosome 1 numerical abnormalities and centromeric content of micronuclei in buccal cells from thyroid cancer and hyperthyroidism patients treated with radioactive iodine. *Mutagenesis* 14(1):121-127.
- *Ramsden D, Passant FH, Peabody CO, et al. 1967. Radioiodine uptakes in the thyroid: Studies of the blocking and subsequent recovery of the gland following the administration of stable iodine. *Health Phys* 13:633-646.
- Ranganathan S, Reddy V. 1995. Human requirements of iodine & safe use of iodized salt. *Indian J Med Res* 102:227-232.
- Rani CSS, Field JB. 1988. Comparison of effects of thyrotropin, phorbol esters, norepinephrine, and carbachol on iodide organification in dog thyroid slices, follicles, and cultured cells. *Endocrinology* 122:1915-1922.
- Rao DV, Narra VR, Howell RW, et al. 1989. In-vivo radiotoxicity of DNA-incorporated ^{125}I compared with that of densely ionising alpha-particles. *Lancet* 2:650-653.

9. REFERENCES

- Rao DV, Narra VR, Howell RW, et al. 1990. Biological consequence of nuclear versus cytoplasmic decays of ^{125}I : Cysteamine as a radioprotector against auger cascades *in vivo*. *Radiat Res* 124:188-193.
- Rapoport B, Spaulding SW. 1996. Mechanism of action of thyrotropin and other thyroid growth factors. In: Braverman LE, Utiger RD, eds. *Werner and Ingbar's the thyroid: A fundamental and clinical text*. Philadelphia, PA: Lippincott-Raven, 207-219.
- Rapoport B, Adams RJ, Rose M. 1977. Cultured thyroid cell adenosine 3',5'-cyclic monophosphate response to thyrotropin: Loss and restoration of sensitivity to iodide inhibition. *Endocrinology* 100:755-764.
- Rapoport B, Caplan R, DeGroot LJ. 1973. Low-dose sodium iodide I 131 therapy in Graves disease. *JAMA* 224(12):1610-1613.
- Rapoport B, West MN, Ingbar SH. 1976. On the mechanism of inhibition by iodine of the thyroid adenylate cyclase response to thyrotropic hormone. *Endocrinology* 99:11-22.
- *Rasmussen RA, Khalil MAK, Gunwardenena R et al. 1982. *Journal of Geophysical Research* 87:3086-3090.
- Rasmussen SN, Hjorth L. 1974. Determination of thyroid volume by ultrasonic scanning. *J Clin Ultrasound* 2(2):143-147.
- *Rasooly L, Burek CL, Rose NR. 1996. Iodine-induced autoimmune thyroiditis in NOD-H-2^{h4} mice. *Clin Immunol Immunopathol* 81(3):287-292.
- Raspe E, Dumont JE. 1994. Control of the dog thyrocyte plasma membrane iodide permeability by the Ca^{2+} -phosphatidylinositol and adenosine 3',5'-monophosphate cascades. *Endocrinology* 135(3):986-995.
- *Raspe E, Dumont JE. 1995. Tonic modulation of dog thyrocyte H_2O_2 generation and I^- uptake by thyrotropin through the cyclic adenosine 3',5'-monophosphate cascade. *Endocrinology* 136(3):965-973.
- Rebello AD, Herms FW, Wagener K. 1990. The cycling of iodine as iodate and iodide in a tropical estuarine system. *Mar Chem* 29:77-93.
- Reddi OS. 1971. Long term genetic effects of ^{131}I in mice. *Indian J Med Res* 59:1420-1423.
- Reddy AR, Kaul A. 1978. Microscopic dose distributions due to iodine isotopes in thyroid. *Radiat Environ Biophys* 15:229-239.
- Reddy PP, Reddy SB, Ebenezer DN, et al. 1982. Response of male germ cells of mouse to acute and fractionated doses of ^{131}I induced radiation. *Can J Genet Cytol* 24:817-820.
- Reed HL. 1996. Environmental influences on thyroid hormone regulation. In: Braverman LE, Utiger RD, eds. *Werner and Ingbar's the thyroid: A fundamental and clinical text*. Philadelphia, PA: Lippincott-Raven, 259-265.
- Reed RR. 1997. Thyroid-associated ophthalmopathy: Treatment. In: Falk SA, ed. *Thyroid disease: Endocrinology, surgery, nuclear medicine, and radiotherapy*. Philadelphia, PA: Lippincott-Raven Publishers, 359-377.
- Rees Smith B, McLachlan SM, Furmaniak J. 1988. Autoantibodies to the thyrotropin receptor. *Endocrine Rev* 9(1):106-121.
- Reeve TS, Hales IB, Smith KV, et al. 1973. Carcinoma of the thyroid in a patient treated with radioiodine for hyperthyroidism. *Med J Aust* 1:993-996.

9. REFERENCES

- *Reifenhäuser C, Heumann KG. 1990. Development of a definitive method for iodine speciation in aquatic systems. *Fresenius J Anal Chem* 336:559-563.
- Reiners C. 1991. Radioiodine treatment of Basedow's disease: Interference and influence factors, risk estimation. *Exp Clin Endocrinol* 97:275-285.
- Reiners C, Herrmann H, Schaffer R, et al. 1983. Incidence and prognosis of thyroid cancer with special regard to oncocytic carcinoma of the thyroid. *Acta Endocrinol Suppl* 252:18.
- Reinhard W, Kohl S, Hollmann D, et al. 1998. Efficacy and safety of iodine in the postpartum period in an area of mild iodine deficiency. *Eur J Med Res* 3:203-210.
- *Reinhardt W, Luster M, Rudorff KH, et al. 1998. Effect of small doses of iodine on thyroid function in patients with Hashimoto's thyroiditis residing in an area of mild iodine deficiency. *Eur J Endocrinol* 139:23-38.
- Reinhardt W, Paul TL, Allen EM, et al. 1988. Effect of l-thyroxine administration on the incidence of iodine induced and spontaneous lymphocytic thyroiditis in the BB/WOR rat. *Endocrinology* 122(3):1179-1181.
- Reish DJ, Geesey GG, Wilkes FG, et al. 1982. Marine and estuarine pollution. *J Water Pollut Control Fed* 54:786-812.
- Revis NW, McCauley P, Holdsworth G. 1986. Relationship of dietary iodide and drinking water disinfectants to thyroid function in experimental animals. *Environ Health Perspect* 69:243-248.
- Ribela MTCP, Marone MMS, Bartolini P. 1999. Use of radioiodine urinalysis for effective thyroid blocking in the first few hours post exposure. *Health Phys* 76(1):11-16.
- Riccabona G, Zechmann W, Unterkircher S, et al. 1983. Epidemiology of thyroid cancer in an iodine deficient area during iodized salt prophylaxis. *Acta Endocrinol Suppl* 252:13.
- Richards EM, Marcus RE. 1993. Acute promyelocytic leukaemia following radioiodine therapy. *Clin Lab Haematol* 15:55-58.
- Richards GE, Brewer ED, Conley SB, et al. 1981. Combined hypothyroidism and hypoparathyroidism in an infant after maternal ¹³¹I administration. *J Pediatr* 99(1):141-143.
- Riddle WR, Roselli RJ, Pou NA. 1990. Modeling flux of free and protein-bound radioisotopes into the pulmonary interstitium. *J Appl Physiol* 68(6):2434-2442.
- Rieger G, Winkler R, Buchberger W, et al. 1995. Iodine distribution in a porcine eye model following iontophoresis. *Ophthalmologica* 209:84-87.
- Riggs DS. 1952. Quantitative aspects of iodine metabolism. *Pharmacol Rev* 4:284-370.
- Rillema JA, Marting C. 1998. Cyclic AMP impairs the PRL stimulation of iodide uptake into mouse mammary tissues. *Proc Soc Exp Biol Med* 219:37-40.
- Rillema JA, Yu TX. 1996. Prolactin stimulation of iodide uptake into mouse mammary gland explants. *Am J Physiol* 271(34):E879-E882.
- Rink T, Schroth H-J, Holle L-H, et al. 1999. [Effects of iodine and thyroid hormones in inducing and treating Hashimoto's thyroiditis.] *Nuklearmedizin* 38:144-149. (German)

9. REFERENCES

- Ritter MA. 1981. The radiotoxicity of iodine-125 in ataxia telangiectasia fibroblasts. *Biochim Biophys Acta* 652:151-159.
- Rivera M, Teruel JL, Castano JC, et al. 1993. Iodine-induced sialadenitis: Report of 4 cases and review of the literature. *Nephron* 63:466-467.
- Rivkees SA, Sklar C, Freemark M. 1998. The management of Graves' disease in children, with special emphasis on radioiodine treatment. *J Clin Endocrinol Metab* 83(11):3767-3776.
- Rivlin RS. 1996a. Vitamin metabolism in hypothyroidism. In: Braverman LE, Utiger RD, eds. *Werner and Ingbar's The thyroid: A fundamental and clinical text*. Philadelphia, PA: Lippincott-Raven, 863-865.
- Rivlin RS. 1996b. Vitamin metabolism in thyrotoxicosis. In: Braverman LE, Utiger RD, eds. *Werner and Ingbar's the thyroid: A fundamental and clinical text*. Philadelphia, PA: Lippincott-Raven, 693-695.
- Robbins J. 1983. Indications for using potassium iodide to protect the thyroid from low level internal irradiation. *Bull N Y Acad Med* 59(10):1028-1038.
- *Robbins J. 1996. Thyroid hormone transport proteins and the physiology of hormone binding. In: Braverman LE, Utiger RD, eds. *Werner and Ingbar's the thyroid: A fundamental and clinical text*. Philadelphia, PA: Lippincott-Raven, 96-110.
- *Robens E, Aumann DC. 1988. Iodine-129 in the environment of a nuclear fuel reprocessing plant: I. ^{129}I and ^{127}I contents of soils, food crops and animal products. *J Environ Radioact* 7:159-175.
- Robens E, Hauschild J, Aumann DC. 1988a. Iodine-129 in the environment of a nuclear fuel reprocessing plant: II. Iodine-129 and iodine-127 contents of soils, forage plants and deer thyroids. *J Environ Radioact* 7:265-274.
- Robens E, Hauschild J, Aumann DC. 1988b. Iodine-129 in the environment of a nuclear fuel reprocessing plant: III. Soil-to-plant concentration factors for Iodine-129 and iodine-127 and their transfer factors to milk, eggs and pork. *J Environ Radioact* 7:37-52.
- Robens-Palavinskas E, Hauschild J, Aumann DC. 1989. Iodine-129 in the environment of a nuclear fuel reprocessing plant: VI. Comparison of measurements of ^{129}I concentrations in soil and vegetation with predictions from a radiological assessment model. *J Environ Radioact* 10:67-78.
- *Robertson JS, Gorman CA. 1976. Gonadal radiation dose and its genetic significance in radioiodine therapy of hyperthyroidism. *J Nucl Med* 17:826-835.
- *Robertson JS, Nolan NG, Wahner HW, et al. 1975. Thyroid radioiodine uptakes and scans in euthyroid patients. *Mayo Clin Proc* 50:79-84.
- Robinson GA, Easnidge DC, Floto F, et al. 1976. Ovarian ^{125}I transference in the laying Japanese quail: Apparent stimulation by FSH and lack of stimulation by TSH. *Poult Sci* 55:1665-1671.
- *Robinson PS, Barker P, Campbell A, et al. 1994. Iodine-131 in breast milk following therapy for thyroid carcinoma. *J Nucl Med* 35:1797-1801.
- *Robison LM, Sylvester PW, Birkenfeld P, et al. 1998. Comparison of the effects of iodine and iodide on thyroid function in humans. *J Toxicol Environ Health* 55:93-106.
- *Robkin MA, Shleien B. 1995. Estimated maximum thyroid doses from ^{129}I releases from the Hanford site for the years 1944-1995. *Health Phys* 69(6):917-922.

9. REFERENCES

- Robson AM. 1981. Vocal-cord paralysis after treatment of thyrotoxicosis with radioiodine. *Br J Radiol* 54:632.
- Roddy MT. 1975a. The effect of KI on the DUB/ICR strain mouse. *Diss Abstr Int B* 36(3):1034.
- Roddy MT 1975b. The effect of KI on the DUB/ICR strain mouse. Ph.D. Dissertation, The Catholic University of America. 70 p.
- *Rodeheaver G, Bellamy W, Kody M, et al. 1982. Bactericidal activity and toxicity of iodine-containing solutions in wounds. *Arch Surg* 117:181-186.
- Rodesch F, Rocmans P, Dumont JE. 1967. Stimulation of thyroidal radioiodine uptake by actinomycin D and fluorouracil-an indirect effect. *Biochem Pharmacol* 16:907-908.
- Rodrigues M, Havlik E, Peskar B, et al. 1998. Prostaglandins as biochemical markers of radiation injury to the salivary glands after iodine-131 therapy? *Eur J Nucl Med* 25(3):265-269.
- Rogau YI, Amvros'eu AP, Darokhina RI, et al. 1994. [Retardation of development of rat fetus by incorporation of iodine-131 isotopes during organogenesis.] *Vestsi Akad Navuk BSSR Ser Biyal Navuk* 3:55-58. (Russian)
- Rognoni JB, Lemarchand-Beraud T, Berthier C, et al. 1982. Effect of long-term iodide refeeding on the synthesis and secretion of T₃, T₄ and TSH in severe iodine deficient rats. *Acta Endocrinol* 101:377-385.
- Rognoni JB, Lemarchand-Beraud T, Berthier C. 1984. Respective roles of circulating T₄ and T₃ in control of TSH secretion in severely iodide-deficient rats. *Experientia* 40:215-217.
- Roland DA, McCready ST, Stonerock RH, et al. 1977. Hypercalcemic effect of potassium iodide on serum calcium in domestic fowl. *Poult Sci* 56:1310-1314.
- Romney BM, Nickoloff EL, Esser PD, et al. 1986. Radionuclide administration to nursing mothers: Mathematically derived guidelines. *Radiology* 160:549-554.
- Ron E. 1997. Cancer risk following radioactive iodine-131 exposures in medicine. In: *Proceedings of the annual meeting of the National Council on Radiation Protection Measures: Implications of new data on radiation cancer risk*. Bethesda, MD: National Cancer Institute, 65-77.
- Ron E, Modan B. 1984. Thyroid and other neoplasms following childhood scalp irradiation. In: Boice KD, Fraument JF, eds. *Radiation carcinogenesis: Epidemiology and biological significance*. New York, NY: Raven Press, 139-151.
- *Ron E, Doody MM, Becker DV, et al. 1998. Cancer mortality following treatment for adult hyperthyroidism. *JAMA* 280(4):347-355.
- *Ron E, Lubin JH, Shore RE, et al. 1995. Thyroid cancer after exposure to external radiation: A pooled analysis of seven studies. *Radiat Res* 141:259-277.
- Ron E, Modan B, Preston D, et al. 1989. Thyroid neoplasia following low-dose radiation in childhood. *Radiat Res* 120:516-531.
- *Rook HL, Suddueth JE, Becker DA. 1975. Determination of Iodine-129 at natural levels using neutron activation and isotopic separation. *Anal Chem* 47:1557-1561.
- Roos DE, Smith JG. 1999. Randomized trials on radioactive iodine ablation of thyroid remnants for thyroid carcinoma-a critique. *Int J Radiat Oncol Biol Phys* 44(3):493-495.

9. REFERENCES

- Rosado M, Borrego LC, Paniagua ME. 1983. Incidence of hypothyroidism after radioiodine treatment for Graves disease. *Bol Asoc Med P R* 75(4):167-169.
- Rose MR, Prescott MC, Herman KJ. 1990. Excretion of iodine-123-hippuran, technetium-99m-red blood cells, and technetium-99m-macroaggregated albumin into breast milk. *J Nucl Med* 31(6):978-984.
- *Rose NR, Saboori AM, Rasooly L, et al. 1997. The role of iodine in autoimmune thyroiditis. *Crit Rev Immunol* 17:511-517.
- *Rosen IB, Palmer JA, Rowen J, et al. 1984. Induction of hyperparathyroidism by radioactive iodine. *Am J Surg* 148:441-445.
- Rosen IB, Strawbridge HG, Bain J. 1975. A case of hyperparathyroidism associated with radiation to the head and neck area. *Cancer* 36:1111-1114.
- Rosenberg D, Grand MJH, Silbert D. 1963. Neonatal hyperthyroidism. *N Engl J Med* 268(6):292-296.
- *Rosenberg FR, Einbinder J, Walzer RA, et al. 1972. Vegetating iododerma. *Arch Dermatol* 105:900-905.
- Rosenberg G. 1958. Biologic half-life of I¹³¹ in the thyroid of healthy males. *J Clin Endocrinol Metab* 18:516-521.
- Rosenthal D. 1981. Kinetic analysis of iodine and thyroxine metabolism in "hot" thyroid nodules. *Metabolism* 30(4):384-392.
- Ross DS. 1996a. Subclinical hypothyroidism. In: Braverman LE, Utiger RD, eds. *Werner and Ingbar's the thyroid: A fundamental and clinical text*. Philadelphia, PA: Lippincott-Raven, 1010-1015.
- Ross DS. 1996b. Subclinical thyrotoxicosis. In: Braverman LE, Utiger RD, eds. *Werner and Ingbar's the thyroid: A fundamental and clinical text*. Philadelphia, PA: Lippincott-Raven, 1016-1020.
- Ross DS. 1998. Syndromes of thyrotoxicosis with low radioactive iodine uptake. *Endocrinol Metab Clin North Am* 27(1):169-185.
- Ross DS, Daniels GH, De Stefano P, et al. 1983. Use of adjunctive potassium iodide after radioactive iodine (¹³¹I) treatment of Graves' hyperthyroidism. *J Clin Endocrinol Metab* 57(2):250-253.
- Rothschild HC. 1974. *A criteria digest on radioactivity in the environment*. Ottawa, Canada: National Research Council Canada.
- *Roti E, Uberti E. 2001. Iodine excess and hyperthyroidism. *Thyroid* 11(5): 493-500.
- *Roti E, Vagenakis AG. 2000. Effect of excess iodide: Clinical aspects. In: Braverman LE, Utiger RD, eds. *Werner and Ingbar's the thyroid: A fundamental and clinical text*. 8th ed. Philadelphia, PA: Lippincott-Williams and Wilkins, 316-329.
- Roti E, Gnudi A, Braverman LE. 1983. The placental transport, synthesis and metabolism of hormones and drugs which affect thyroid function. *Endocrine Rev* 4:131-149.
- Roti E, Minelli R, Gardini E, et al. 1990. Iodine-induced hypothyroidism in euthyroid subjects with a previous episode of subacute thyroiditis. *J Clin Endocrinol Metab* 70:1581-1585.
- Roti E, Minelli R, Gardini E, et al. 1992. Iodine-induced subclinical hypothyroidism in euthyroid subjects with a previous episode of amiodarone-induced thyrotoxicosis. *J Clin Endocrinol Metab* 75(5):1273-1277.

9. REFERENCES

- Roudebush CP, Hoye KE, DeGroot LJ. 1977. Compensated low-dose ^{131}I therapy of Graves' disease. *Ann Intern Med* 87:441-443.
- Rozenson R, Gusev B, Hoshi M, et al. 1996. A brief summary of results of radiation studies on residents in the Semipalatinsk area, 1957-1993. In: Nagataki S, Yamashita S, eds. Nagasaki symposium radiation and human health: Proposal from Nagasaki. Amsterdam, the Netherlands: Elsevier, 127-145.
- Rubery ED. 1990. Practical aspects of prophylactic stable iodine usage. In: Rubery E, Smales E, eds. Iodine prophylaxis following nuclear accidents. Oxford, UK: Pergamon Press, 141-150.
- *Rubow S, Klopper J, Wasserman H, et al. 1994. The excretion of radiopharmaceuticals in human breast milk: Additional data and dosimetry. *Eur J Nucl Med* 21:144-153.
- Rueggsegger GJ, Schultz LH. 1980. Iodine in field milk samples [Abstract]. *J Dairy Sci* 63(Suppl 1):115.
- Ruiz De Ona C, Obregon MJ, Escobar Del Rey F, et al. 1988. Developmental changes in rat brain 5'-deiodinase and thyroid hormones during the fetal period: The effects of fetal hypothyroidism and maternal thyroid hormones. *Pediatr Res* 24(5):588-594.
- Russell JL, Hahn PB. 1971. Public health aspects of iodine-129 from the nuclear power industry. *Radiol Health Data Rep* 12(4):189-194.
- *Russell KP, Rose H, Starr P. 1957. The effects of radioactive iodine on maternal and fetal thyroid function during pregnancy. *Surg Gynecol Obstet* 104:560-564.
- *Ruwhof C, Drexhage HA. 2001. Iodine and thyroid autoimmune disease in animal models. *Thyroid* 11(5):427-436
- Rybakowa M, Tylek D, Soltysik-Wilk E, et al. 1991. [Epidemiologic study in children from the Krakow region following the Chernobyl accident.] *Endokrynol Pol* 42(2):253-261. (Polish)
- *Saboori AM, Rose NR, Bresler HS et al. 1998a. Iodination of human thyroglobulin (Tg) alters its immunoreactivity. I. Iodination alters multiple epitopes of human Tg. *Clin. Exp. Immunol.* 113:297-302.
- *Saboori AM, Rose NR, Burek CL. 1998b. Iodination of human thyroglobulin alters its immunoreactivity. II. Fine specificity of a monoclonal antibody that recognizes iodinated thyroglobulin. *Clin. Exp. Immunol.* 113:303-308.
- *Saboori AM, Rose NR, Yuhasz SC, Amzal M, Burek CL. 1999. Peptides of human thyroglobulin reactive with sera of patients with autoimmune thyroid disease. *J. Immunol.* 163:6244-6250.
- *Sachs BA, Siegel E, Horwitt BN, et al. 1972. Bread iodine content and thyroid radioiodine uptake: A tale of two cities. *Br Med J* 1:79-81.
- Saddok C, Gafni M, Gross J. 1978. Effect of iodide on the adenylyl cyclase system of the mouse thyroid in vivo. *Acta Endocrinol* 88:517-527.
- Safa A, Schumacher OP. 1976. Follow-up of children treated with ^{131}I . *N Engl J Med* 294(1):54.
- Safa AM, Skillern PG. 1975. Treatment of hyperthyroidism with a large initial dose of sodium iodide I 131. *Arch Intern Med* 135:673-675.
- Safa AM, Schumacher OP, Rodriguez-Antunez A. 1975. Long-term follow-up results in children and adolescents treated with radioactive iodine (^{131}I) for hyperthyroidism. *N Engl J Med* 292:167-171.

9. REFERENCES

- *Safran M, Paul TL, Roti TL, et al. 1987. Environmental factors affecting autoimmune thyroid disease. *Endocrinol Metab Clin N Am* 16(2): 327-342.
- Saito K, Kaneko H, Sato K, et al. 1991. Hepatic UDP-glucuronyltransferase(s) activity toward thyroid hormones in rats: Induction and effects on serum thyroid hormone levels following treatment with various enzyme inducers. *Toxicol Appl Pharmacol* 111:99-106.
- Saito K, Yamamoto K, Takai T, et al. 1983. Inhibition of iodide accumulation by perchlorate and thiocyanate in a model of the thyroid iodide transport system. *Acta Endocrinol* 104(4):456-461.
- Saji M, Kohn LD. 1990. Effect of hydrocortisone on the ability of thyrotropin to increase deoxyribonucleic acid synthesis and iodide uptake in FRTL-5 rat thyroid cells: Opposite regulation of adenosine 3',5'-monophosphate signal action. *Endocrinology* 127(4):1867-1876.
- Saji M, Kohn LD. 1991. Insulin and insulin-like growth factor-I inhibit thyrotropin-increased iodide transport in serum-depleted FRTL-5 rat thyroid cells: Modulation of adenosine 3',5'-monophosphate signal action. *Endocrinology* 128:1136-1143.
- Saji M, Isozaki O, Tsushima T, et al. 1988. The inhibitory effect of iodide on growth of rat thyroid (FRTL-5) cells. *Acta Endocrinol* 119:145-151.
- *Salbu B, Steinnes E, Pappas AC. 1975. Multielement neutron activation analysis of fresh water using Ge(Li) gamma spectrometry. *Anal Chem* 47:1011-1016.
- *Saller B, Fink H, Mann K. 1998. Kinetics of acute and chronic iodine excess. *Exp Clin Endocrinol Diabetes* 106(Suppl 3):S34-S38.
- Samuel AM, Unnikrishnan TP, Baghel NS, et al. 1995. Effect of radioiodine therapy on pulmonary alveolar-capillary membrane integrity. *J Nucl Med* 36:783-787.
- Samuel S, Pildes RS, Lewison M, et al. 1971. Neonatal hyperthyroidism in an infant born of an euthyroid mother. *Am J Dis Child* 121:440-443.
- Santana C, Burek CL, Talor M, et al. 1997. Evaluation of thyroid glands from NOD-H-2^{h4} mice with iodine-induced thyroiditis [Abstract]. *Mol Biol Cell* 8(Suppl):453A.
- Santisteban P, Obregon MJ, Rodriguez-Pena A, et al. 1982. Are iodine-deficient rats euthyroid? *Endocrinology* 110(5):1780-1789.
- Sapozink MD, Palos B, Goffinet DR, et al. 1983. Combined continuous ultra low dose rate irradiation and radiofrequency hyperthermia in the C3H mouse. *Int J Radiat Oncol Biol Phys* 9:1357-1365.
- Sarkar SD, Beierwaltes WH, Gill SP, et al. 1976. Subsequent fertility and birth histories of children and adolescents treated with ¹³¹I for thyroid cancer. *J Nucl Med* 17:460-464.
- Sasaki H, Matsumoto S, Shuyo H, et al. 1992. Gross ascites as a first manifestation of primary hypothyroidism due to post-treatment of radioiodine therapy for Graves' disease. *Intern Med* 31:256-259.
- Sastry KSR. 1992. Biological effects of the Auger emitter iodine-125: A review. Report No. 1 of AAPM Nuclear Medicine Task Group No. 6. *Med Physics* 19(6):1361-1370.
- Sato A, Ohtake M, Kotani M, et al. 1972. Effects of methimazole and propylthiouracil on blood disappearance and urinary excretion of iodide in the rat. *Proc Soc Exp Biol Med* 141(1):119-122.
- Sato K, Robbins J. 1981. Thyroid hormone metabolism in primary cultured rat hepatocytes. *J Clin Invest* 68:475-493.

9. REFERENCES

- Sato T, Inoue M, Suzuki Y, et al. 1975. [Hypothyroidism caused by ¹³¹I contained in mothers' milk: Its association with polycystic ovary and kidney calculus.] *Horumon To Rinsho* 23(6):535-538. (Japanese)
- *Savoie JC, Massin JP, Thomopoulos P, et al. 1975. Iodine-induced thyrotoxicosis in apparently normal thyroid glands. *J Clin Endocrinol Metab* 41:685-691.
- Sawers JSA, Toft AD, Irvine WJ, et al. 1980. Transient hypothyroidism after iodine-131 treatment of thyrotoxicosis. *J Clin Endocrinol Metab* 50:226-229.
- Sawin CT, Castelli WP, Hershman JM, et al. 1985. The aging thyroid: Thyroid deficiency in the Framingham study. *Arch Intern Med* 145:1386-1388.
- *Saxena Km, Chapman EM, Pryles CV. 1962. Minimal dosage of iodide required to suppress uptake of iodine-131 by normal thyroid. *Science* 138:430-431.
- Scanlon MF, Toft AD. 1996. Regulation of thyrotropin secretion. In: Braverman LE, Utiger RD, eds. *Warner and Ingbar's the thyroid: A fundamental and clinical text*. Philadelphia, PA: Lippincott-Raven, 220-240.
- Schaffer R, Muller HA, Ebel R. 1983. Distribution pattern of malignant thyroid tumors in an endemic goitre area. *Acta Endocrinol Suppl* 252:13-14.
- *Schaug J, Rambaek JP, Steinnes E, et al. 1990. Multivariate analysis of trace element data from moss samples used to monitor atmospheric deposition. *Atmos Environ* 24A(10):2625-2631.
- Scherbaum WA. 1996. Iodine-induced thyroiditis in the non-obese diabetic (NOD) mouse-more questions than answers. *Exp Clin Endocrinol Diabetes* 104(Suppl 3):20-23.
- Scheuttkopf H. 1979. [Radioecological reduction of acute and long-term contamination of the environment by iodine-129]. (German). In: Kernforschungszen. Karlsruhe, [Ber.] KFK, KFK 2770, Samml. Vortr. Jahreskolloquium 1978 Proj Nukl Sicherheit, 206-225.
- Schilling YR, Abellan F, Escribano JRD, et al. 1998. Acute leukemias after treatment with radioiodine for thyroid cancer. *Haematologica* 83(8):767-768.
- Schlenker RA. 1985. Internal emitter limits for iodine, radium and radon daughters. *Proc Annu Meet Natl Counc Radiat Prot Meas* 6:131-181.
- Schlumberger MJ. 1988. Papillary and follicular thyroid carcinoma. *N Engl J Med* 338(5):297-306.
- Schlumberger M, Caillou B. 1996. Miscellaneous tumors of the thyroid. In: Braverman LE, Utiger RD, eds. *Werner and Ingbar's the thyroid: A fundamental and clinical text*. Philadelphia, PA: Lippincott-Raven, 961-965.
- Schlumberger M, De Vathaire F. 1996. [¹³¹Iodine: Medical use. Carcinogenetic and genetic effects.] *Ann Endocrinol (Paris)* 57:166-167. (French)
- Schlumberger M, De Vathaire F, Ceccarelli C, et al. 1996. Exposure to radioactive iodine-131 for scintigraphy or therapy does not preclude pregnancy in thyroid cancer patients. *J Nucl Med* 37(4):606-612.
- Schlumberger M, Parmentier N, Chavaudra J, et al. 1988. [Management in cases of accidental contamination by iodine radioisotopes.] *Presse Med* 17(8):386-388. (French)

9. REFERENCES

- Schlumberger M, Parmentier C, de Vathaire F, et al. 1997. Iodine-131 and external radiation in the treatment of local and metastatic thyroid cancer. In: Falk SA, ed. *Thyroid disease: Endocrinology, surgery, nuclear medicine, and radiotherapy*. Philadelphia, PA: Lippincott-Raven Publishers, 601-617.
- *Schmidt A, Schnabel C, Handle J, et al. 1998. On the analysis of iodine-129 and iodine-127 in environmental materials by accelerator mass spectrometry and ion chromatography. *Sci Total Environ* 223:131-156.
- Schmucki O, Sulmoni A, Pupato F. 1973. [Late bladder complications after radioactive iodine therapy of thyroid tumors.] *Urologe A* 12(3):130-133. (German)
- Schneeweiss FHA, Myers DK, Tisljar-Lentulis G, et al. 1985. Low oxygen enhancement ratios for strand breaks induced by decays of ¹²⁵I in DNA of human T1 cells stored at 0 degrees C. *Radiat Prot Dosim* 13(1-4):237-239.
- Schneider AB, Ron E. 1996. Carcinoma of follicular epithelium. In: Braverman LE, Utiger RD, eds. *Werner and Ingbar's the thyroid: A fundamental and clinical text*. Philadelphia, PA: Lippincott-Raven, 902-909.
- Schneider AB, Gierlowski TC, Shore-Freedman E, et al. 1995. Dose-response relationships for radiation-induced hyperparathyroidism. *J Clin Endocrinol Metab* 80(1):254-257.
- Schneider AB, Recant W, Pinsky SM, et al. 1986. Radiation-induced thyroid carcinoma. *Ann Intern Med* 105:405-412.
- Schneider AB, Ron E, Lubin J, et al. 1993. Dose-response relationships for radiation-induced thyroid cancer and thyroid nodules: Evidence for the prolonged effects of radiation on the thyroid. *J Clin Endocrinol Metab* 77(2):362-369.
- Schneider AB, Shore-Freedman E, Ryo UY, et al. 1985. Radiation-induced tumors of the head and neck following childhood irradiation. *Medicine* 64(1):1-15.
- Schneppe MM. 1972. Determination of total iodine and iodate in sea water and in various evaporites.. *Anal Chim Acta* 58:83-89.
- Schnyder UW, Taugner M, Rossbach J. 1969. [Histology of pathological iodine reactions of the skin.] *Dermatologica* 139(4):266-270. (German)
- Schober O, Gunter H-H, Schwazrock R, et al. 1987. [Hematologic long-term modifications after radioiodine therapy of the carcinoma of the thyroid gland: I. Peripheral blood count modifications.] *Strahlenther Onkol* 163:464-474. (German)
- Schreiber G, Southwell BR, Richardson SJ. 1995. Hormone delivery systems to the brain-transthyretin. *Exp Clin Endocrinol* 103:75-80.
- Schreiber V, Rohacova J. 1971. Increase in thyroid radioiodine uptake following the administration of cyproterone acetate. *Experientia* 27(7):848-849.
- *Schull WJ, Otake M, Yoshimaru H. 1988. Effect on intelligence test score of prenatal exposure to ionizing radiation in Hiroshima and Nagasaki: A comparison of the T65DR and DS86 dosimetry systems. Radiation Effects Research Foundation. RERF TR 3-88. Research project 24-62.
- Schurizek BA, Kraglund K, Andreasen F, et al. 1989. Antroduodenal motility and gastric emptying. Gastroduodenal motility and pH following ingestion of paracetamol. *Aliment Pharmacol Ther* 3:93-101.

9. REFERENCES

- Schwarz G, Hoffman FO. 1979. Imprecision of dose predictions for radionuclides released to the atmosphere: An application of the Monte-Carlo-Simulation-Technique for iodine transported via the pasture-cow-milk pathway. Presented at the 1979 Winter Meeting of the American Nuclear Society, November 11-16, 1979. San Francisco, California. CONF-791103-48.
- Schwarzfischer P, Harlass G, Kreul H-G, et al. 1981. [Iodine induced hyperthyroidism in old age. Part 1: Multimorbidity, autonomous tissue and possibilities for iodine contamination.] *Fortschr Med* 99(44):1834-1838. (German)
- Schwarzfischer P, Harlass G, Kreul H-G, et al. 1982. [Iodine-induced hyperthyroidism in the aged. 2. Pathomechanism, differential diagnosis and therapy problems.] *Fortschr Med* 100(5):153-158. (German).
- Scott GR, Forfar JC, Toft AD. 1984. Graves' disease and atrial fibrillation: The case for even higher doses of therapeutic iodine-131. *Br Med J* 289:399-400.
- Scully JM, Uno JM, McIntyre M, et al. 1990. Radiation-induced prostatic sarcoma: A case report. *J Urol* 144:746-748.
- *Seabold JE, Ben-Haim S, Pettit WA, et al. 1993. Diuretic-enhanced I-131 clearance after ablation therapy for differentiated thyroid cancer. *Radiology* 187:839-842.
- Sedelnikova OA, Panyutin IG, Thierry AR, et al. 1998. Radiotoxicity of iodine-125-labeled oligodeoxyribonucleotides in mammalian cells. *J Nucl Med* 39(8):1412-1418.
- Segers O, Musch W, Schoors DF. 1993. Early complications of radioiodine treatment for hyperthyroidism. *Acta Clin Belg* 48(4):253-258.
- *Segers O, Spapen H, Steenssens L, et al. 1988. Treatment of severe iodine-induced hyperthyroidism with plasmapheresis. *Acta Clin Belg* 43:335-343.
- Segura ET, Roussel JD, Satterlee DG, et al. 1979. Interaction of exogenous corticotropin and environment on protein bound iodine and other plasma biochemical parameters. *J Dairy Sci* 62:278-283.
- *Sekura RD, Sato K, Cahnmann HJ, et al. 1981. Sulfate transfer to thyroid hormones and their analogs by hepatic aryl sulfotransferases. *Endocrinology* 108(2):454-456.
- Self GJ, Rigby PJ, Passarelli MC, et al. 1990. Characteristics and localisation of ¹²⁵I ion binding in mammalian airways. *Eur J Pharmacol* 176:169-176.
- Senczuk W, Slusarek D. 1981. [Effect of detergents on iodophor toxicity. I. Effect of detergents on acute toxicity and iodophor cumulation coefficient.] *Rocz Panstw Zakl Hig* 32(3):197-200. (Czech.)
- Senczuk W, Slusarek D. 1982. [Effect of detergents on iodophor toxicity. III. Effect of detergents on iodine absorption into blood, retention in the organs and urinary excretion.] *Rocz Panstw Zakl Hig* 33(3):207-213. (Czech.)
- Senczuk W, Slusarek D, Sadowski C. 1982. [Effect of detergents on iodophor toxicity. IV. Iodine content of the blood, urine and tissues of animals exposed to the long-term action of iodophor.] *Rocz Panstw Zakl Hig* 33(4):307-309. (Czech.)
- Senekowitsch R, Kriegel H. 1984. Diaplacental transfer and distribution of some radionuclides in fetal organs at different stages of gestation - experimental results. *EUR* 8067:183-197.
- Senior B, Chernoff HL. 1971. Iodide goiter in the newborn. *Pediatrics* 47(3):510-515.

9. REFERENCES

*Setchell BP, Waites GMH. 1975. The blood-testis barrier. In: Creep RO, Astwood EB, Geiger SR, eds. Handbook of physiology: Endocrinology V. Washington, DC: American Physiological Society.

Shafer RB, Nuttall FQ. 1975. Acute changes in thyroid function in patients treated with radioactive iodine. *Lancet* 2(7936):635-637.

Shah DH, Patel MC, Sulkhe PV. 1969. Effect of actinomycin D on the uptake of radioiodine by thyroidal and extrathyroidal tissues-I. *Biochem Pharmacol* 18:1487-1493.

Shah KH, Oslapas R, Calandra DB, et al. 1983. Effects of radiation on parafollicular C cells of the thyroid gland. *Surgery* 94(6):989-994.

Shanshiashvili TA, Gracheva LM. 1981. Genetic effects of decay of radionuclide products of division of nucleofuel in cells of the yeast *Saccharomyces cerevisiae*. Role of transmutation: I. Lethal mutagenic effects and the nature of mutations induced by yttrium-91 decay. *Sov Genet* 17:1370-1376. Translation of *Genetika*, 17(12):2115-2124.

Shao J, Chen Q, Guo C, et al. 1995. [Effect of lithium on iodine uptake in thyroid cells in culture.] *Zhonghua Heyixue Zazhi* 15(4):242-244. (Chinese)

Shapiro B. 1993. Optimization of radioiodine therapy of thyrotoxicosis: What have we learned after 50 years? *J Nucl Med* 34(10):1638-1644.

Sheeler LR, Skillern PG, Schumacher OP, et al. 1984. Radioiodine-induced thyroid storm: A point of controversy. *Am J Med* 76(4):A98.

Sheldon J. 1983. Effects of amiodarone in thyrotoxicosis. *Br Med J* 286:267-268.

*Shelly WB. 1967. Generalized pustular psoriasis induced by potassium iodide. *JAMA* 201(13):133-138.

*Shen DHY, Kloos RT, Mazzaferri EL, Jhiang SM. 2001. Sodium iodide symporter in health and disease. *Thyroid* 11(5):415-425.

Sheppard MI, Hawkins JL. 1995. Iodine and microbial interactions in an organic soil. *J Environ Radioact* 29(2):91-109.

Sheppard MI, Thibault DH. 1988. Migration of technetium, iodine, neptunium, and uranium in the peat of two minerotrophic mires. *J Environ Qual* 17(4):644-653.

Sheppard MI, Thibault DH. 1991. A four-year mobility study of selected trace elements and heavy metals. *J Environ Qual* 20:101-114.

*Sheppard MI, Thibault DH, Mcmurry J, et al. 1995. Factors affecting the soil sorption of iodine. *Water Air Soil Pollut* 83:51-67.

Sheppard S. 1995. When does chemical toxicity of ^{129}I become important? In: Environmental impact of radioactive releases: Proceedings of an international symposium on environmental impact of radioactive releases. Vienna, Austria: International Atomic Energy Agency, 837-883.

Sheppard SC, Evenden WG. 1995. Toxicity of soil iodine to terrestrial biota, with implications for ^{129}I . *J Environ Radioact* 27(2):99-116.

*Sheppard SC, Evenden WG, Amiro BD. 1993. Investigation of the soil-to-plant pathway for I, Br, Cl and F. *J Environ Radioact* 21:9-32.

9. REFERENCES

- *Sheppard SC, Evenden WG, Schwartz WJ. 1995. Ingested soil: Bioavailability of sorbed lead, cadmium, cesium, iodine, and mercury. *J Environ Qual* 24:498-505.
- Sherer TT, Thrall KD, Bull RJ. 1991. Comparison of toxicity induced by iodine and iodide in male and female rats. *J Toxicol Environ Health* 32:89-101.
- *Sheridan PJ, Zoller WH. 1989. Elemental composition of particulate material sampled from the Arctic haze aerosol. *J Atmos Chem* 9:363-381.
- Sherwin JR. 1978. Iodide induced suppression of thyrotropin-stimulated adenosine 3',5'-monophosphate production in cat thyroid slices. *Horm Res* 9:271-278.
- Sherwin JR, Seaford JW. 1986. Effect of valinomycin on thyroid iodide transport and TSH-stimulated cAMP formation. *Am J Physiol* 250(13):E164-E168.
- *Shetty KR, Duthie EH. 1990. Thyrotoxicosis induced by topical iodine application. *Arch Intern Med* 150:2400-2401.
- Shevchenko VA, Ramaya LK, Pomerantseva MD, et al. 1989. Genetic effects of ¹³¹I in reproductive cells of male mice. *Mutat Res* 226:87-91.
- Shibuya M. 1991. Studies on the iodine-binding factors of human parotid saliva. *Shika Gakuho* 91(12):1587-1603.
- *Shilo S, Hirsch HJ. 1986. Iodine-induced hyperthyroidism in a patient with a normal thyroid gland. *Postgrad Med J* 62:661-662.
- Shimizu T, Shishiba Y. 1975. Effect of triiodothyronine or iodide on the thyroidal secretion *in vitro*: Inhibition of TSH- and dibutyryl-cyclic-AMP induced endocytosis. *Endocrinol Jpn* 22(1):55-60.
- Shimon I, Kneller A, Olchovsky D. 1995. Chronic myeloid leukaemia following ¹³¹I treatment for thyroid carcinoma: A report of two cases and review of the literature. *Clin Endocrinol* 43:651-654.
- Shimura H, Endo T, Tsujimoto G, et al. 1990. Characterization of alpha₁-adrenergic receptor subtypes linked to iodide efflux in rat FRTL cells. *J Endocrinol* 124:433-441.
- *Shimura H, Haraguchi K, Miyazaki A, et al. 1997. Iodide uptake and experimental ¹³¹I therapy in transplanted undifferentiated thyroid cancer cells expressing the Na⁺/I⁻ symporter gene. *Endocrinology* 138(10):4493-4496.
- Shinohara K. 1994. [A preliminary study on the effects of start age of uptake on dose assessment for chronic ingestion of radionuclides.] *Hoken Butsuri* 29(2):201-205. (Japanese)
- Shishiba Y, Solomon DH. 1967. Effect of amphotericin B on thyroidal iodide concentration. *Endocrinology* 81:467-474.
- Shleien B, Halperin JA, Bilstad JM, et al. 1983. Recommendations on the use of potassium iodide as a thyroid-blocking agent in radiation accidents: An FDA update. *Bull N Y Acad Med* 59(10):1009-1019.
- Sho FK, Kondo Y. 1988. Inhibition by islet-activating protein, pertussis toxin, of P₂-purinergic receptor-mediated iodide efflux and phosphoinositide turnover in FRTL-5 cells. *Endocrinology* 123(2):1035-1043.
- Sho K, Okajima F, Akiyama H, et al. 1989. Requirement of insulin growth factor I plus hydrocortisone for the regeneration of thyrotropin (TSH)-dependent mechanism of I⁻ efflux and CA²⁺ mobilization in FRTL-5 cells during TSH depletion. *Endocrinology* 124:598-604.

9. REFERENCES

- Shopsin B, Shenkman L, Blum M, et al. 1973. Iodine and lithium-induced hypothyroidism: Documentation of synergism. *Am J Med* 55:695-699.
- Shore RE. 1989. Risk of thyroid cancer after diagnostic doses of radioiodine. *J Natl Cancer Inst* 81(9):713-715.
- *Shore RE. 1992. Issues and epidemiological evidence regarding radiation-induced thyroid cancer. *Radiat Res* 131:98-111.
- Shore RE, Albert RE, Pasternack BS. 1976. Follow-up study of patients treated by x-ray epilation for tinea capitis. *Arch Environ Health* 31:14-24.
- Shore RE, Hildreth N, Dvoretzky P, et al. 1993a. Benign thyroid adenomas among persons x-irradiated in infancy for enlarged thymus glands. *Radiat Res* 134:217-223.
- Shore RE, Hildreth N, Dvoretzky P, et al. 1993b. Thyroid cancer among persons given x-ray treatment in infancy for an enlarged thymus gland. *Am J Epidemiol* 137(10):1068-1080.
- Sichuk G, Money WL, Der BK, et al. 1968. Cancer of the thyroid, goitrogenesis and thyroid function in Syrian (golden) hamsters. *Cancer* 21(5):952-963.
- Siegemund B, Weyers W. 1987. [Teratological studies of low-molecular weight polyvinylpyrrolidone-iodine complex in rabbits.] *Arzneim Forsch* 37(3):340-341. (German)
- Sikov MR. 1969. Effect of age on the iodine-131 metabolism and the radiation sensitivity of the rat thyroid. *Radiat Res* 38:449-459.
- Sikov MR, Meznarich HK, Traub RJ. 1991. Comparison of placental transfer and localization of caesium strontium and iodine in experimental animals and women. *Int J Radiat Biol* 60(3):553-555.
- Silva CAM, Merkt H, Bergamo PNL, et al. 1987. Consequence of excess iodine supply in a thoroughbred stud in southern Brazil. *J Reprod Fertil Suppl* 35:529-533.
- *Silva JE. 2000a. Catecholamines and the sympathoadrenal system in thyrotoxicosis. In: Braverman LE, Utiger RD, eds. *Werner and Ingbar's the thyroid: A fundamental and clinical text*. 8th ed. Philadelphia, PA: Lippincott-Raven, 642-651.
- *Silva JE. 2000b. Catecholamines and the sympathoadrenal system in hypothyroidism. In: Braverman LE, Utiger RD, eds. *Werner and Ingbar's the thyroid: A fundamental and clinical text*. 8th ed. Philadelphia, PA: Lippincott-Raven, 820-823.
- Sim RTS. 1993. Thrombocytopenia associated with exposure to iodine. *Hawaii Med J* 52(10):262.
- Simon SL. 1996. A summary of health, environmental and sociological consequences from atomic testing in the Marshall Islands. In: Nagasaki S, Yamashita S, eds. *Nagasaki symposium radiation and human health: Proposal from Nagasaki*. Amsterdam, the Netherlands: Elsevier, 155-165.
- Simon SL, Graham JC. 1996. Dose assessment activities in the Republic of the Marshall Islands. *Health Phys* 71(4):438-456.
- Simon SL, Graham JC. 1997. Findings of the first comprehensive radiological monitoring program of the Republic of the Marshall Islands. *Health Phys* 73(1):66-85.
- *Simon SL, Lloyd RD, Till JE, et al. 1990. Development of a method to estimate thyroid dose from fallout radioiodine in a cohort study. *Health Phys* 59(5):669-691.

9. REFERENCES

- Simonnet F, Orts JC, Simonnet G. 1989. Destruction of genotoxic wastes mixed with radioactive products. *Health Phys* 57(6):885-890.
- Simonovic I, Kargacin B, Kostial K. 1986. The effect of composite oral treatment for internal contamination with several radionuclides on ^{131}I thyroid uptake in humans. *J Appl Toxicol* 6(2):109-111.
- Simonovic I, Kostial K, Kargacin B. 1984. ^{131}I uptake in human thyroid after antidote treatment for mixed fission products contamination. *Int J Radiat Biol* 46(4):459-462.
- Simpson CL, Hempelmann LH, Fuller LM. 1955. Neoplasia in children treated with x-rays in infancy for thyroid enlargement. *Radiology* 64:840-845.
- Sinclair WK, Abbatt JD, Farran HEA, et al. 1956. A quantitative autoradiographic study of radioiodine distribution and dosage in human thyroid glands. *Br J Radiol* 29:36-41.
- Sindainovic J, Liewendahl K. 1976. Studies on proteolytic activity and function of the thyroid gland in rats administered excess iodide. *Acta Endocrinol* 82:728-736.
- Singh B, Dhawan D, Chand B, et al. 1994. Biokinetics of iodine-131 in rat thyroid following lead and lithium supplementation. *Biol Trace Elem Res* 40:287-293.
- Singh B, Dhawan D, Mangal PC, et al. 1992. The influence of lead toxicity on the biological half-life of iodine-131 Rose Bengal in rat liver. *Med Sci Res* 20(17):623-624.
- Singh VN, Chaikoff IL. 1966. Effects of 1-methyl-2-mercaptoimidazole and perchlorate on the insulin-mediated enhancement of ^{131}I incorporation into iodoamino acids by fetal thyroid glands in organ culture. *Endocrinology* 78:339-342.
- Singhal RK, Narayanan U, Bhat IS. 1998. Investigations on interception and translocation of airborne ^{85}Sr , ^{131}I , ^{137}Cs in beans, spinach and radish plants. *Water Air Soil Pollut* 101:163-176.
- Sit KH, Kanagasuntheram R. 1972. A structural analysis of congenital limb deformities in experimental hyperthyroid tadpoles. *J Embryol Exp Morphol* 28(1):223-234.
- Skare S, Frey HMM. 1980. Iodine induced thyrotoxicosis in apparently normal thyroid glands. *Acta Endocrinol* 94:332-336.
- Sleight SD, Mangkoewidjojo S, Akoso BT, et al. 1978. Polybrominated biphenyl toxicosis in rats fed an iodine-deficient, iodine-adequate, or iodine-excess diet. *Environ Health Perspect* 23:341-346.
- *Small MD, Bezman A, Longarni AE, et al. 1961. Absorption of potassium iodide from gastro-intestinal tract. *Proc Soc Exp Biol Med* 106:450-452.
- Smallridge RC. 1996. Metabolic, physiologic, and clinical indexes of thyroid function. In: Braverman LE, Utiger RD, eds. *Werner and Ingbar's the thyroid: A fundamental and clinical text*. Philadelphia, PA: Lippincott-Raven, 397-405.
- Smallridge RC, Gist ID, Ambroz C. 1991. 8-Diethylamino-octyl-3,4,5-trimethoxybenzoate, a calcium store blocker, increases calcium influx, inhibits alpha-1 adrenergic receptor calcium mobilization, and alters iodide transport in FRTL-5 rat thyroid cells. *Endocrinology* 129(1):542-549.
- Smallridge RC, Gist ID, Kiang JG. 1992. $\text{Na}^+\text{-H}^+$ antiport and monensin effects on cytosolic pH and iodide transport in FRTL-5 rat thyroid cells. *Am J Physiol* 262(25):E834-E839.

9. REFERENCES

- Smallridge RC, Wartofsky L, Burman KD. 1982. The effect of experimental hyperthyroidism and hypothyroidism on 5'-monodeiodination of 3,3',5'-triiodothyronine and 3',5'-diiodothyronine by rat liver and kidney. *Endocrinology* 111:2066-2069.
- *Smanik PA, Liu Q, Furminger TL, et al. 1996. Cloning of the human sodium iodide symporter. *Biochem Biophys Res Commun* 226:339-345.
- *Smanik PA, Ryu K-Y, Theil KS, et al. 1997. Expression, exon-intron organization, and chromosome mapping of the human sodium iodide symporter. *Endocrinology* 138(8):3555-3558.
- Smerdely P, Boyages SC, Wu D, et al. 1989. Topical iodine-containing antiseptics and neonatal hypothyroidism in very-low-birthweight infants. *Lancet* 2(8664):661-664.
- Smidt KP, Johnson E. 1975. Undetected iatrogenic hypothyroidism: A late complication of radio-iodine therapy. *N Z Med J* 81:325-328.
- Smit E, Whiting DA, Feld S. 1994. Iodine-induced hyperthyroidism caused by acne treatment. *J Am Acad Dermatol* 31(1):115-117.
- Smith CS, Howard NJ. 1973. Propranolol in treatment of neonatal thyrotoxicosis. *J Pediatr* 83(6):1046-1048.
- Smith GE. 1917. Fetal athyrosis. A study of the iodine requirement of the pregnant sow. *J Biol Chem* 29:215-225.
- Smith JM, Broadway JA, Strong AB. 1978. United States population dose estimates for iodine-131 in the thyroid after the Chinese atmospheric nuclear weapons tests. *Science* 200:44-46.
- *Smith MB, Xue H, Takahashi H, et al. 1994. Iodine 131 thyroid ablation in female children and adolescents: Long-term risk of infertility and birth defects. *Ann Surg Oncol* 1(2):128-131.
- Smith RN, Wilson GM. 1967. Clinical trial of different doses of ¹³¹I in treatment of thyrotoxicosis. *Br Med J* 1:129-132.
- Smith TJ. 1996a. Connective tissue in hypothyroidism. In: Braverman LE, Utiger RD, eds. *Werner and Ingbar's the thyroid: A fundamental and clinical text*. Philadelphia, PA: Lippincott-Raven, 796-798.
- Smith TJ. 1996b. Connective tissue in thyrotoxicosis. In: Braverman LE, Utiger RD, eds. *Werner and Ingbar's the thyroid: A fundamental and clinical text*. Philadelphia, PA: Lippincott-Raven, 598-606.
- *Snyder PJ. 2000a. The pituitary in hypothyroidism. In: Braverman LE, Utiger RD, eds. *Werner and Ingbar's the thyroid: A fundamental and clinical text*. 8th ed. Philadelphia, PA: Lippincott-Raven, 836-840.
- *Snyder PJ. 2000b. The pituitary in thyrotoxicosis. In: Braverman LE, Utiger RD, eds. *Werner and Ingbar's the thyroid: A fundamental and clinical text*. 8th ed. Philadelphia, PA: Lippincott-Raven, 634-636.
- Snyder RD. 1988. Role of active oxygen species in metal-induced DNA strand breakage in human diploid fibroblasts. *Mutat Res* 193:237-246.
- Snyder S. 1978. Vocal cord paralysis after radioiodine therapy. *J Nucl Med* 19(8):975-976.
- Sobrinho LG, Limbert ES, Santos MA. 1977. Thyroxine toxicosis in patients with iodine induced thyrotoxicosis. *J Clin Endocrinol Metab* 45:25-29.

9. REFERENCES

- Socolow EL, Hashizume A, Neriishi S, et al. 1963. Thyroid carcinoma in man after exposure to ionizing radiation. *N Engl J Med* 268(8):406-410,444.
- *Sodd VJ, Velten RJ, Saenger EL. 1975. Concentrations of the medically useful radionuclides, technetium-99m and iodine-131 at a large metropolitan waste water treatment plant. *Health Phys* 28:355-359.
- *Soldat JK. 1976. Radiation doses from iodine-129 in the environment. *Health Phys* 30:61-70.
- Soliman M, Kaplan E, Abdel-Latif A, et al. 1995. Does thyroidectomy, radioactive iodine therapy, or antithyroid drug treatment alter reactivity of patients' T cells to epitopes of thyrotropin receptor in autoimmune thyroid diseases? *J Clin Endocrinol Metab* 80:2312-2321.
- Sololowska R, Fuks T, Olejnik E. 1976. [Determination of the level of iodine content in milk caused by the penetration of same from iodophoric preparations used during milking.] *Rocz Panstw Zakl Hig* 27(1):33-40. (Czech.).
- Solomon BL, Evaul JE, Burman KD, et al. 1987. Remission rats with antithyroid drug therapy: Continuing influence of iodine intake? *Ann Intern Med* 107:510-512.
- Solov'ev AS, Gurova NV, Shchebnikova NE. 1996. [The effect of incorporation of various doses of ¹³¹I on the immunological reactions.] *Byull Eksp Biol Med* 121(6):664-666. (Russian)
- Sonmez S, Ikbal M, Yildirim M, et al. 1997. Sister chromatid exchange analysis in patients exposed to low dose of iodine-131 for thyroid scintigraphy. *Mutat Res* 393:259-262.
- Sorcini MC, Diodata A, Fazzini C, et al. 1988. Influence of environmental iodine deficiency on neonatal thyroid screening results. *J Endocrinol Invest* 11:309-312.
- *Soria C, Allegue F, Espana A, et al. 1990. Vegetating iododerma with underlying systemic diseases: Report of three cases. *J Am Acad Dermatol* 22:418-422.
- Spate VL, Morris JS, Nichols TA, et al. 1998. Longitudinal study of iodine in toenails following IV administration of an iodine-containing contrast agent. *J Radioanal Nucl Chem* 236(1-2):71-76.
- *Spaulding SW, Burrow WR, Himmelhoch HM et al. 1972. The inhibitory effect of lithium on thyroid hormone release in both euthyroid and thyrotoxic patients. *J Clin Endocrinol Metab* 35:905-911.
- Speck WT, Carr HS, Rosenkranz HS. 1976. DNA damage produced by povidone-iodine in cultured human diploid cells. *J Toxicol Environ Health* 1:977-980.
- Spector R, Lorenzo AV. 1974. The effects of salicylate and probenecid on the cerebrospinal fluid transport of penicillin, aminosalicilylic acid and iodide. *J Pharmacol Exp Ther* 188(1):55-65.
- Speert H, Quimby EH, Werner SC. 1951. Radioiodine uptake by the fetal mouse thyroid and resultant effects in later life. *Surg Gynecol Obstet* 91:230-242.
- Speight JW, Baba WI, Wilson GM. 1968. The effect of propylthiouracil and ¹³¹I on rat thyroid chromosomes. *J Endocrinol* 42:267-275.
- Spencer CA. 1996. Thyroglobulin. In: Braverman LE, Utiger RD, eds. *Werner and Ingbar's the thyroid: A fundamental and clinical text*. Philadelphia, PA: Lippincott-Raven, 406-415.
- Spencer RP, Chapman CN, Rao H. 1983. Thyroid carcinoma after radioiodide therapy for hyperthyroidism: Analysis based on age, latency, and administered dose of I-131. *Clin Nucl Med* 8(5):216-219.

9. REFERENCES

- *Spencer RP, Spitznagle LA, Karimeddini MK, et al. 1986. Breast milk content of ^{131}I in a hypothyroid patient. *Nucl Med Biol* 13(5):585.
- Spezzano P, Giacomelli R. 1990. Radionuclide concentrations in air and their deposition at Saluggia (northwest Italy) following the Chernobyl nuclear accident. *J Environ Radioact* 12:79-91.
- Spiegel W, Reiners C, Borner W. 1985. Sialadenitis following iodine-131 therapy for thyroid carcinoma. *J Nucl Med* 26(7):816-817.
- Spryshkova NA, Egorova LT, Palinkashi DG. 1976. [Study of different states of iodine metabolism in rats by means of whole-body radiometry.] *Probl Endokrinol (Mosk)* 22(2):70-75. (Russian)
- Sridama V, McCormick M, Kaplan EL, et al. 1984. Long-term follow-up study of compensated low-dose ^{131}I therapy for Graves' disease. *N Engl J Med* 311(7):426-432.
- Stabin MG, Watson EE, Marcus CS, et al. 1991. Radiation dosimetry for the adult female and fetus from iodine-131 administration in hyperthyroidism. *J Nucl Med* 32(5):808-813.
- Stadel BV. 1976. Dietary iodine and risk of breast, endometrial, and ovarian cancer. *Lancet* 1(7965):890-891.
- Staffurth JS. 1987. Hypothyroidism following radioiodine treatment of thyrotoxicosis. *J R Coll Phys London* 21(1):55-57.
- Staffurth JS, Holl-Allen RTJ. 1988. Follicular carcinoma of the thyroid following radioactive iodine treatment for Graves' disease. *Postgrad Med J* 64:878-880.
- Stanbury JB. 1990. The physiological basis for blockade of radioiodine retention by iodine. In: Rubery E, Smales E, eds. *Iodine prophylaxis following nuclear accidents*. Oxford, UK: Pergamon Press, 57-64.
- Stanbury JB. 1992. Iodine and human development. *Med Anthropol* 13:413-423.
- *Stanbury JB, Ermans AE, Bourdoux P, et al. 1998. Iodine-induced hyperthyroidism: Occurrence and epidemiology. *Thyroid* 8(1):83-100.
- Stara JF, Hoar RM, Ball HH. 1966. Localization of radioiodine during early organogenesis by means of autoradiography [Abstract]. *Health Phys* 12:1206.
- Starr P. 1974. Thyroid cancer after iodine-131 therapy [Letter]. *JAMA* 227(8):940.
- *Stassi G, DiLiberto, Todaro, et al. 2000. Control of target cell survival in thyroid autoimmunity by T helper cytokines via regulation of apoptotic proteins. *Nat Immunol* 6:483-488.
- *Stather JB, Greenhalgh JR. 1983. The metabolism of iodine in children and adults. National Radiation Protection Board, Chilton, Didcot, Oxfordshire, England. Report No. NRPB-R140.
- Steen M. 1993. Review of the use of povidone-iodine (PVP-I) in the treatment of burns. *Postgrad Med J* 69(Suppl 3):S84-S92.
- Steidle B. 1989. Iodine-induced hyperthyroidism after contrast media: Animal experimental and clinical studies. *Fortschr Geb Rontgenstrahlen Nuklearmed Ergänzungsbd* 128:6-14.
- Steidle B, Grehn S, Seif FJ. 1980. [Hyperthyroidism induced by iodine-containing contrast medium.] *Minerva Med* 71(22):1560-1565. (Italian)

9. REFERENCES

- Steinnes E. 1995. A critical evaluation of the use of naturally growing moss to monitor the deposition of atmospheric metals. *Sci Total Environ* 160/161:243-249.
- Steinnes E, Rambek JP, Hanssen JE. 1992. Large scale multi-element survey of atmospheric deposition using naturally growing moss as biomonitor. *Chemosphere* 25(5):735-752.
- Stenback F, Rowland J. 1978. Carcinogenic activation of benzo(a)pyrene by iodine and ferric chloride in the respiratory tract of Syrian golden hamsters. *Experientia* 34(8):1065-1066.
- Stepanov SA, Tupikinia EB. 1997. [Histofunctional state of the thyroid gland in pregnancy and in progeny under experimental regime of iodine intake.] *Arkh Patol* 59(5):39-44. (Russian)
- *Stephenson M, Motycka M. 1994. Review and assessment of methods for the measurement and speciation of iodine in fresh water. Atomic Energy of Canada Ltd., Whiteshell Laboratories, Pinawa, Manitoba (NTIS PB95-160487).
- *Sternthal E, Lipworth L, Stanley B, et al. 1980. Suppression of thyroid radioiodine uptake by various doses of stable iodide. *N Engl J Med* 303(19):1083-1088.
- *Stetar EA, Boston HL, Larsen IL, et al. 1993. The removal of radioactive cobalt, cesium, and iodine in a conventional municipal wastewater treatment plant. *Water Environ Res* 65(6):630-639.
- Stevens RH, Cheng HF. 1987. Lymphocyte proliferative responses to mitogens in rats having an ancestry of a perinatal iodine-131 insult. *Environ Res* 44:94-102.
- Stevens RH, Cole DA, Liu PT, et al. 1983. Postpartum cell-mediated immunity induced in the rat following perinatal exposure to iodine-131. *Anticancer Res* 3:347-352.
- Stevens RH, Lindholm PA, Cole DA, et al. 1986. Genealogical memory to perinatal iodine-131 exposure in rats: I. Alteration in natural immunity. *Anticancer Res* 6:925-930.
- *Stewart JC. 1975. Epidemiology and pathogenesis of iodine-induced thyrotoxicosis in Northern Tasmania. *N Z Med J* 81:25-26.
- *Stewart JC, Vidor GI. 1976. Thyrotoxicosis induced by iodine contamination of food-a common unrecognised condition? *Br Med J* 1:372-375.
- Stewart RB, May FE, Cullen SI. 1979. Dermatologic adverse drug reactions in hospitalized patients. *Am J Hosp Pharm* 36:609-612.
- *St. Germain DL. 1997. Molecular basis of thyroid disease. In: Falk SA, ed. *Thyroid disease: Endocrinology, surgery, nuclear medicine, and radiotherapy*. Philadelphia, PA: Lippincott-Raven Publishers, 183-208.
- *Stieglitz KJL. 1995. Identification and quantification of volatile organic components in emissions of waste incinerator plants. *Chemosphere* 30:1249-1260.
- *Stockigt JR. 2000. Serum thyrotropin and thyroid hormone measurements and assessment of thyroid hormone transport. In: Braverman LE, Utiger RD, eds. *Werner and Ingbar's the thyroid: A fundamental and clinical text*. 8th ed. Philadelphia, PA: Lippincott-Raven, 376-392.
- Stockton LK, Thomas WC. 1978. Absence of neonatal goiter during maternal use of iodinated water. *Am J Clin Nutr* 31:717.
- Stoffer SS, Hamburger JI. 1976. Inadvertent ¹³¹I therapy for hyperthyroidism in the first trimester of pregnancy. *J Nucl Med* 17(2):146-149.

9. REFERENCES

- Stoffer SS, Hamburger JI. 1978. Avoiding inadvertent fetal radiation resulting from ¹³¹I therapy for hyperthyroidism. In: Spencer RP, ed. *Therapy in nuclear medicine*. New York, NY: Grune & Stratton, 129-138.
- Stolberg HO, McClennan BL. 1991. Ionic versus nonionic contrast use. *Curr Probl Diagn Radiol* 20(2):47-88.
- Stolc V. 1972. Regulation of iodine metabolism in human leukocytes by adenosine 3',5'-monophosphate. *Biochim Biophys Acta* 264:285-288.
- Stolc V. 1975. Effect of pituitary factor on iodine uptake and cyclic adenosine 3',5'-monophosphate formation in human polymorphonuclear leukocytes. *Biochem Med* 12:226-233.
- Stoll R, Maraud R. 1963. [Induction of thyroid tumors in rats treated with propylthiouracil and radioactive iodine.] *Bull Assoc Fr Etude Cancer* 50(3):389-398. (French)
- Stoll R, Maraud R, Laplanche P, et al. 1966. [On gamma adenomas of the thyroid in rats subjected to cancerogenic and non-cancerogenic treatments.] *C R Seances Soc Biol Fil* 160(12):2288-2291. (French)
- Stone OJ. 1971. What are the non-endocrine biologic effects of iodides? *Med Times* 99(12):143-149,155,200.
- *Stone OJ. 1985. Proliferative iododerma: A possible mechanism. *Int J Dermatol* 24(9):565-566.
- Stowe CM. 1981. Iodine, iodides, and iodism. *J Am Vet Med Assoc* 179(4):334-336.
- Stowe HD, Rangel F, Anstead C, et al. 1980. Influence of supplemental dietary vitamin A on the reproductive performance of iodine-toxic rats. *J Nutr* 110:1947-1957.
- Strain GM, Flory W. 1981. Toxicology of ethylenediamine dihydriodide [Letter]. *J Am Vet Med Assoc* 179:751,72.
- *Straub CP, Murthy GK, Campbell JE. 1966. Iodine-131 in foods. *Residue Rev* 13:33-68.
- Strum JM. 1979. Effect of iodide-deficiency on rat mammary gland. *Virchows Arch B* 30:209-220.
- Stubbe P, Schulte F-J, Heidemann P. 1986. Iodine deficiency and brain development. *Bibl Nutr Dieta* 38:206-208.
- Stubner D, Gartner R, Greil W, et al. 1987. Hypertrophy and hyperplasia during goitre growth and involution in rats - separate bioeffects of TSH and iodine. *Acta Endocrinol* 116:537-548.
- Studer H, Kohler H, Burgi H, et al. 1970. Goiters with high radioiodine uptake and other characteristics of iodine deficiency in rats chronically treated with aminoglutethimide. *Endocrinology* 87:905-914.
- Studer H, Kohler H, Burgi H, et al. 1972. Possible importance of thyroidal iodine compartments in the adaptation of thyroid hormone secretion to antithyroid drugs. *Endocrinology* 91:1154-1159.
- Stuges WT, Shaw GE. 1993. Halogens in aerosols in central Alaska. *Atmos Environ* 27A(17/18):2969-2977.
- Sturgis CD. 1999. Radioactive iodine-associated cytomorphologic alterations in thyroid follicular epithelium: Is recognition possible in fine-needle aspiration specimens? *Diagn Cytopathol* 21(3):207-210.

9. REFERENCES

- Suarez RC, Lopez Bejerano GM, Arado JO, et al. 1998. [System for whole-body measurement and estimation of doses by different irradiation routes in a group of infants from areas affected by the Chernobyl accident.] *Rev Cubana Fis* 15(2):130-133. (Spanish)
- Subramanyam S, Murthy DK, Reddi OS. 1975. Cytological investigations on the effects of I^{131} in male mice. *Indian J Med Res* 63(12):1680-1687.
- Sugawara M, Yamaguchi DT, Lee HY, et al. 1990. Hydrogen peroxide inhibits iodide influx and enhances iodide efflux in cultured FRTL-5 rat thyroid cells. *Acta Endocrinol* 122:610-616.
- Sunder S, Vikis AC. 1987. Raman spectra of iodine oxyacids produced by the gas-phase reaction of iodine with ozone in the presence of water vapour. *Can J Spectrosc* 32(2):45-48.
- Sundick RS. 1990. Iodine in autoimmune thyroiditis. *Immunol Ser* 52:213-228.
- *Sundick RS, Herdegen DM, Brown TR, et al. 1987. The incorporation of dietary iodine and thyroglobulin increases its immunogenicity. *Endocrinology* 120:2078-2084.
- Sunitha Y, Udaykumar P, Raghunath M. 1997. Changes in blood-brain barrier nutrient transport in the offspring of iodine-deficient rats and their preventability. *Neurochem Res* 22(7):785-790.
- Surks MI. 1967. Determination of iodide clearance and exit rate constants in incubated thyroid lobes. *Endocrinology* 80:1020-1027.
- Svadlenkova M, Konecny J, Obdrzalek M, et al. 1990. Distribution and transport kinetics of radionuclides ^{99}Mo and ^{131}I in a simulated aquatic ecosystem. *Bull Environ Contam Toxicol* 44:535-541.
- Swedlund HA. 1971. Iodide myxedema with facial swelling simulating angioneurotic edema. *Allergy* 47(6):341-345.
- *Szabolcs I, Podoba J, Feldkamp J, et al. 1997. Comparative screening for thyroid disorders in old age in areas of iodine deficiency, long-term iodine prophylaxis and abundant iodine intake. *Clin Endocrinol* 47:87-92.
- Szabolcs I, Schultheiss H, Astier H, et al. 1991. Effects of triiodothyronine, triiodothyroacetic acid, iopanoic acid and iodide on the thyrotropin-releasing hormone-induced thyrotropin release from superfused rat pituitary fragments. *Acta Endocrinol* 125:427-434.
- Sztanyik LB, Turai I. 1988. Modification of radioiodine incorporation into the fetuses and newborn rats by thyroid blocking agents. *Acta Physiol Hung* 72(3-4):343-354.
- Tabintharan S, Sundram FX, Chew LS. 1997. Radioiodine ($I-131$) therapy and the incidence of hypothyroidism. *Ann Acad Med Singapore* 26:128-131.
- Tadrose TG, Maisey MN, Fui SCNT, et al. 1981. The iodine concentration in benign and malignant thyroid nodules measured by x-ray fluorescence. *Br J Radiol* 54:626-629.
- Taher MA, Loken MK, Bantle JP. 1991. Radioiodine therapy in thyrotoxicosis. *J Indian Med Assoc* 89(4):86-88.
- Tai M, Zhi-heng Y, Ti-zhang L, et al. 1982. High-iodide endemic goiter. *Chin Med J* 95(9):692-696.
- *Tajiri J, Higashi K, Morita M, et al. 1986. Studies of hypothyroidism in patients with high iodine intake. *J Clin Endocrinol Metab* 63:412-417.

9. REFERENCES

- *Takahashi T, Fujimori K, Simon SL, et al. 1999. Thyroid nodules, thyroid function and dietary iodine in the Marshall Islands. *Int J Epidemiol* 28:742-749.
- *Takahashi T, Trott KR, Fujimori K, et al. 1997. An investigation into the prevalence of thyroid disease on Kwajalein Atoll, Marshall Islands. *Health Phys* 73(1):199-213.
- *Takasu N, Handa Y, Shimizu Y, et al. 1984. Electrophysiological and morphological cell polarity and iodine metabolism in cultured porcine and human (normal and Graves') thyroid cells. *J Endocrinol* 101:189-196.
- Takasu N, Ohno S, Takasu M, et al. 1988. Polarized thyroid cells in monolayers cultured on collagen gel: Their cytoskeleton organization, iodine uptake, and resting membrane potentials. *Endocrinology* 122:1021-1026.
- Takasu N, Sato A, Yamada T, et al. 1982. Refractoriness of TSH- and PGE₂-stimulated iodine metabolism in cultured porcine thyroid cells, evidence for refractoriness at the level of cAMP action. *Acta Endocrinol* 99:530-539.
- Takegawa K, Mitsumori K, Onodera H, et al. 1998. Induction of squamous cell carcinomas in the salivary glands of rats by potassium iodide. *Jpn J Cancer Res* 89:105-109.
- Takeuchi K, Suzuki H, Sawada M, et al. 1970. Effect of excessive iodide administration on the proteolytic activity of the thyroid gland. *Endocrinology* 86:1239-1244.
- Takeuchi S, Hosokawa S, Kachi T, et al. 1966. [A case of thyroid crisis followed to ¹³¹I therapy-with special reference to the hepatic lesions.] *Naika* 18(1):163-166. (Japanese)
- Takiyama Y, Tanaka H, Takiyama Y, et al. 1994. The effects of hydrocortisone and RU486 (mifepristone) on iodide uptake in porcine thyroid cells in primary culture. *Endocrinology* 135(5):1972-1979.
- Tallstedt L, Lundell G. 1997. Radioiodine treatment, ablation, and ophthalmopathy: A balanced perspective. *Thyroid* 7(2):241-245.
- Tallstedt L, Lundell G, Topping O, et al. 1992. Occurrence of ophthalmopathy after treatment for Graves' hyperthyroidism. *N Engl J Med* 326:1733-1738.
- Tam M. 1988. Australian Dermato-Pathology Society case presentation: Acute painful nodules on the head and neck. *Australas J Dermatol* 29:179-180.
- Tamdor J. 1971. Consideration of stable iodine in the environment in the evaluation of maximum permissible concentrations for iodine-129. *Radiol Health Data Rep* 12(12):611-614.
- Tamura T, Mitsumori K, Onodera H, et al. 1999. Inhibition of thyroid iodine uptake and organification in rats treated with kojic acid. *Toxicol Sci* 47:170-175.
- Tan TT, Morat P, Ng ML, et al. 1989. Effects of Lugol's solution on the thyroid function in normals and patients with untreated thyrotoxicosis. *Clin Endocrinol* 30:645-649.
- Tanaami S, Katamine S, Hoshino N, et al. 1985. Histopathological study on rats fed iodine-enriched eggs long-term (7 and 9 months). *J Nutr Sci Vitaminol* 31:29-42.
- Tanigawa K, Yamishita S, Nagataki S. 1995. Pancytopenia after repeated radioiodine treatment on metastatic thyroid cancer to bone. *Chin Med J* 108:796-797.

9. REFERENCES

- Taniguchi S-I, Shong M, Giuliani C, et al. 1998. Iodide suppression of major histocompatibility class I gene expression in thyroid cells involves enhancer A and the transcription factor NF-kb. *Mol Endocrinol* 12:19-33.
- Tarasenko LV, Varga SV, Demchenko VN, et al. 1994. [Effect of ¹³¹I incorporation on male rat reproductive system and dose-dependent effects.] *Probl Endokrinol (Mosk)* 40(3):45-47. (Russian)
- Targovnik HM, Gluzman BE, Coleoni AH, et al. 1980. Effects of phenylbutazone on thyroid iodine metabolism in vitro. *Acta Endocrinol* 94:64-70.
- Tarutani O, Kondo T, Horiguchi-Sho K. 1975. The effect of iodide administration on hog thyroid gland and the composition of thyroglobulin and 27-S iodoprotein. *Endocrinol Jpn* 22(5):389-397.
- Taurog A. 1970. Thyroid peroxidase-catalyzed iodination of thyroglobulin; inhibition by excess iodide. *Arch Biochem Biophys* 139:212-220.
- *Taurog A. 1996. Hormone synthesis. In: Braverman LE, Utiger RD, eds. *Werner and Ingbar's the thyroid: A fundamental and clinical text*. Philadelphia, PA: Lippincott-Raven, 47-84.
- *Taurog A. 2000. Hormone synthesis: Thyroid iodine metabolism. In: Braverman LE, Utiger RD, eds. *Werner and Ingbar's the thyroid: A fundamental and clinical text*. 8th ed. Philadelphia, PA: Lippincott-Williams and Wilkins, 61-84.
- *Taurog A, Dorris M, Doerge DR. 1994. Evidence for a radical mechanism in peroxidase-catalyzed coupling: I. Steady state experiments with various peroxidases. *Arch Biochem Biophys* 315:82.
- Taylor DM. 1981. The radiotoxicology of iodine. *J Radioanal Chem* 65(1-2):195-208.
- Terahara A, Nakano T, Ishikawa A, et al. 1996. Dose-volume histogram analysis of high dose rate intracavitary brachytherapy for uterine cervix cancer. *Int J Radiat Oncol Biol Phys* 35(3):549-554.
- Teraoka K, Minakuchi K, Kuzime T, et al. 1991. Lithium and carbamazepine effects on iodide metabolising enzymes from the porcine thyroid. *Lithium* 2:37-42.
- Tezelman S, Grossman RF, Siperstein AE, et al. 1994. Radioiodine-associated thyroid cancers. *World J Surg* 18:522-528.
- Theodoropoulos LE, Braverman LE, Vagenakis AG. 1979. Iodide-induced hypothyroidism: A potential hazard during perinatal life. *Science* 205:502-503.
- *Thieblemont P, Marble G, Perrault G, et al. 1965. Evaluation de la retention respiratoire et de l'elimination du radioiode apres contamination aeriennne du singe. *Int J Radiat Biol* 9(3):219-231.
- Thomas GA, Williams ED. 1999. Thyroid stimulating hormone (TSH)-associated follicular hypertrophy and hyperplasia as a mechanism of thyroid carcinogenesis in mice and rats. In: Capen CC, Dybing E, Rice JM, et al., eds. *Species differences in thyroid, kidney and urinary bladder carcinogenesis*. Lyon, France: International Agency for Research on Cancer, 45-59.
- Thomas PJ. 1997. Predicting Chernobyl childhood thyroid cancers from incoming data. *Nucl Energy (Br Nucl Energy Soc)* 36(3):209-221.
- *Thomas RL, Scott JK, Chiffelle TL. 1970. Metabolism and toxicity of inhaled and injected ¹³¹I in the rat. *Am Ind Hyg Assoc J* 31:213-220.
- Thomas WC, Malagodi MH, Oates TW, et al. 1979. Effects of an iodinated water supply. *Trans Am Clin Climatol Assoc* 90:153-162.

9. REFERENCES

- *Thompson DE, Mabuchi K, Ron E, et al. 1994. Cancer incidence in atomic bomb survivors. Part II: Solid tumors, 1958-1987. *Radiat Res* 137:S17-S67.
- Thomson JA, Riley ID. 1966. Neonatal thyrotoxicosis associated with maternal hypothyroidism. *Lancet* 1(7438):635-636.
- Thomson WH, Harding LK. 1995. Radiation protection issues associated with nuclear medicine out-patients. *Nucl Med Commun* 16:879-892.
- Thorpe SM. 1976. Increased uptake of iodide by hormone-responsive compared to hormone-independent mammary tumors in GR mice. *Int J Cancer* 18:345-350.
- Thorsteinsson B, Kirkegaard C. 1977. Iodine-induced hyperthyroidism and bronchial asthma. *Lancet* 2(8032):294.
- *Thrall KD, Bull RJ. 1990. Differences in the distribution of iodine and iodide in the Sprague-Dawley rat. *Fundam Appl Toxicol* 15:75-81.
- Thrall KD, Sauer RL, Bull RJ. 1992. Evidence of thyroxine formation following iodine administration in Sprague-Dawley rats. *J Toxicol Environ Health* 37:535-548.
- Thurston V, Williams ED. 1982. The effect of radiation on thyroid C cells. *Acta Endocrinol* 99:72-78.
- Tighe WJ. 1952. Temporary hypoparathyroidism following radioactive iodine treatment for thyrotoxicosis. *J Clin Endocrinol Metab* 12:1220-1222.
- Tiku ML, Farias AE, Johnson SC. 1976. Iodide myxoedema simulating filariasis. *Indian J Med Sci* 30(9):291-292.
- Tisell L-E, Carlsson S, Fjalling M, et al. 1985. Hyperparathyroidism subsequent to neck irradiation. *Cancer* 56:1529-1533.
- *Todd CH, Allain T, Gomo ZAR, et al. 1995. Increase in thyrotoxicosis associated with iodine supplements in Zimbabwe. *Lancet* 346:1563-1564.
- Toft AD, Irvine WJ, Hunter WM, et al. 1974a. Anomalous plasma TSH levels in patients developing hypothyroidism in the early months after ¹³¹I therapy for thyrotoxicosis. *J Clin Endocrinol Metab* 39:607-609.
- Toft AD, Seth J, Hunter WM, et al. 1974b. Plasma-thyrotropin and serum-thyroxine in patients becoming hypothyroid in the early months after iodine-131. *Lancet* 1(7860):704-705.
- Tokuda Y, Kasagi K, Iida Y, et al. 1988. Inhibition of thyrotropin-stimulated iodide uptake in FRTL-5 thyroid cells by crude immunoglobulin fractions from patients with goitrous and atrophic autoimmune thyroiditis. *J Clin Endocrinol Metab* 67(2):251-258.
- Tomlinson C, Nowles KW, McDougall IR. 1991. Papillary cancer in a patient treated with radioiodine for Graves' hyperthyroidism: Case report and a review of the risk. *Clin Nucl Med* 16(10):729-731.
- Tomonaga M, Nonaka H, Matsuo T. 1996. Atomic bomb irradiation and human leukemias. In: Nagasaki S, Yamashita S, eds. *Nagasaki symposium radiation and human health: Proposal from Nagasaki*. Amsterdam, the Netherlands: Elsevier, 197-215.
- *Tong Q, Ryu K-Y, Jhiang SM. 1997. Promoter characterization of the rat Na⁺/I⁻ symporter gene. *Biochem Biophys Res Commun* 239:34-41.

9. REFERENCES

- Tony JC, Verghese R, Mathew G. 1994. Radio iodine induced thyroid storm. *J Assoc Physicians India* 42(11):924-925.
- *Topliss DJ, Kolliniatis E, Barlow JW, et al. 1989. Uptake of 3,5,3'-triiodothyronine by cultured rat hepatoma cells is inhibitable by nonbile acid cholephils, diphenylhydantoin, and nonsteroidal antiinflammatory drugs. *Endocrinology* 124:980-986.
- Toran L. 1994. Radionuclide contamination in groundwater: Is there a problem? In: *Environmental science pollution control series*. New York, NY: M. Dekker, 437-453.
- *Tosti A, Vincenzi C, Bardazzi F, et al. 1990. Allergic contact dermatitis due to povidone-iodine. *Contact Dermatitis* 23:197-198.
- Townsend JD. 1961. Hypoparathyroidism following radioactive iodine therapy for intractable angina pectoris. *Ann Intern Med* 55:662-663.
- *Tracy BL, Walker WB, McGregor RG. 1989. Transfer of milk to ¹³¹I and ¹³⁷Cs released during the Chernobyl reactor accident. *Health Phys* 56(2):239-243.
- Tran N, Laplante M, LeBel E, et al. 1970. The effect of sodium iodide on the oxidation in vivo of [1-¹⁴C] L-tyrosine to ¹⁴CO₂ in normal rats: A vibrating-reed electrometer-ionization chamber method. *Arch Int Physiol Biochim* 78:909-917.
- Trapasso F, Martelli ML, Battaglia C, et al. 1996. The v-erbA oncogene selectively inhibits iodide uptake in rat thyroid cells. *Oncogene* 12(9):1879-1888.
- *Tresch DD, Sweet DL, Keelan MHJ, et al. 1974. Acute iodide intoxication with cardiac irritability. *Arch Intern Med* 134:760-762.
- Triggs SM, Williams ED. 1977. Irradiation of the thyroid as a cause of parathyroid adenoma. *Lancet* 1:593-594.
- *Tronko ND, Bogdanova TI, Epstein EV, et al. 1996. Thyroid cancer in children and adolescents in Ukraine (analysis of the situation in 1994). In: Nagasaki S, Yamashita S, eds. *Nagasaki symposium radiation and human health: Proposal from Nagasaki*. Amsterdam, the Netherlands: Elsevier, 3-13.
- *Trowbridge FL, Matovinovic J, McLaren GD, et al. 1975. Iodine and goiter in children. *Pediatrics* 56:82-90.
- *Truesdale VW, Smith PJ. 1975. The automatic determination of iodide or iodate in solution by catalytic spectrophotometry, with particular reference to river water. *Analyst* 100:111-123.
- Tseng F-Y, Rani CSS, Field JB. 1989. Effect of iodide on glucose oxidation and ³²P incorporation into phospholipids stimulated by different agents in dog thyroid slices. *Endocrinology* 124(3):1450-1455.
- Tsuchiya T, Ito K, Murata M. 1996. [An evaluation of the incidence of hyperparathyroidism after ¹³¹I treatment for Basedow disease (Part I).] *Kaku Igaku* 33(7):729-735. (Japanese)
- Tsuchiya Y, Saji M, Isozaki O, et al. 1990. Effect of lithium on deoxyribonucleic acid synthesis and iodide uptake in porcine thyroid cells in culture. *Endocrinology* 126(1):460-465.
- *Tsukada H, Ishida J, Narita O. 1991. Particle-size distributions of atmospheric ¹²⁹I and ¹²⁷I aerosols. *Atmos Environ* 25A(5/6):905-908.
- *Tsunogai S. 1971. Determination of iodine in sea water by an improved Sugawara method. *Anal Chim Acta* 55:355-359.

9. REFERENCES

- Tsushima T, Arai M, Isozaki O, et al. 1994. Interaction of endothelin-1 with porcine thyroid cells in culture: A possible autocrine factor regulating iodine metabolism. *J Endocrinol* 142:463-470.
- Tsushima T, Arai M, Saji M, et al. 1988. Effects of transforming growth factor-beta on deoxyribonucleic acid synthesis and iodine metabolism in porcine thyroid cells in culture. *Endocrinology* 123:1187-1194.
- *Tubiana M. 1982. Metabolism and radiotoxicity of radionuclides: Iodine. In: *Radionuclide: Metabolism and toxicity. Proceedings of the symposium. Paris, France: Masson, 49-81.*
- Tucker MA, Jones PHM, Boice JD, et al. 1991. Therapeutic radiation at a young age is linked to secondary thyroid cancer. *Cancer Res* 51:2885-2888.
- Tunbridge WMG, Evered DC, Hall R, et al. 1977. The spectrum of thyroid disease in a community: The Whickham survey. *Clin Endocrinol* 7:481-493.
- Tunbridge WMG, Harsoulis P, Goolden AWG. 1974. Thyroid function in patients treated with radioactive iodine for thyrotoxicosis. *Br Med J* 3:89-92.
- Turner FB, Martin WE. 1964. Food-chain relationships of iodine-131 in Nevada following the Sedan test of July 1962. Laboratory of Nuclear Medicine and Radiation Biology, University of California, Los Angeles, California. PNE-236f, Project 62.83.
- Tvedten HW, Till GO. 1985. Effect of povidone, povidone-iodine, and iodide on locomotion (in vitro) of neutrophils from people, rats, dogs, and rabbits. *Am J Vet Res* 46(8):1797-1800.
- Tyler DD. 1968. Influence of mitochondrial inhibitors on the respiration and energy-dependent uptake of iodide by thyroid slices. *Biochem J* 107:121-123.
- Tzen K-Y, Oster ZH, Wagner HJ, et al. 1980. Role of iron-binding proteins and enhanced capillary permeability on the accumulation of gallium-67. *J Nucl Med* 21(1):31-35.
- Uchida S, Muramatsu Y, Sumiya M, et al. 1991. Biological half-life of gaseous elemental iodine deposited onto rice grains. *Health Phys* 60(5):675-679.
- Uchimura H, Amir SM, Ingbar SH. 1979. Failure of organic iodine enrichment to influence the binding of bovine thyrotropin to rat thyroid tissue. *Endocrinology* 104:1207-1210.
- Ulmer DD. 1977. Trace elements. *N Engl J Med* 6:318-321.
- Umans RS, Leski SA, Ts'o POP. 1969. Chemical linkage of carcinogenic 3,4-benzpyrene to DNA in aqueous solution induced by peroxide and iodine. *Nature* 221:763-764.
- Underwood EJ. 1971. Iodine. In: *Trace elements in human and animal nutrition. New York, NY: Academic Press, 281-322.*
- Unger J. 1989. Thionamides and iodide in iodine-induced thyrotoxicosis [Letter]. *Acta Clin Belg* 44(1):61.
- Unger J, Boeynaems JM, Van Herle A, et al. 1979. *In vitro* nonbutanol-extractable iodine release in dog thyroid. *Endocrinology* 105(1):225-231.
- Unger J, Surmont DWA, Sarot J, et al. 1989. 24 H-kinetics of iodide uptake in amiodarone induced hypothyroidism. *Thyroidology* 2:101-102.
- *UNSCEAR. 1993. Sources, effect and risks of ionizing radiation. Report to the general assembly, New York: United Nations.

9. REFERENCES

- *UNSCEAR. 2000. Sources, effect and risks of ionizing radiation. Report to the general assembly, New York: United Nations. ANNEX J. Exposures and Effects of the Chernobyl Accident, 451-566.
- Untoro J, Schultink W, Gross R, et al. 1998. Efficacy of different types of iodized oil [Letter]. *Lancet* 351:752-753.
- Upton AC. 1981. Health impact of the Three Mile Island accident. *Ann N Y Acad Sci* 365:63-75.
- Ursu HI, Dumitriu L, Grigorie D, et al. 1993. Effects of radioiodine therapy in hyperthyroidism (thyroid function, thyroid volume, Graves' ophthalmopathy, thyrotoxic heart disease). *Rom J Endocrinol* 31(3-4):155-163.
- Usala SJ. 1997. Thyroid hormone resistance syndromes. In: Falk SA, eds. *Thyroid disease: Endocrinology, surgery, nuclear medicine, and radiotherapy*. Philadelphia, PA: Lippincott-Raven Publishers, 223-230.
- *USC. 2001. Listed precursor for controlled substance. U.S. Code. 21 USC 802. <http://www4.law.cornell.edu/uscode/21/802.text.html>. May 16, 2001.
- *U.S. DHHS. 1985. SEER cancer incidence and mortality in the United States, 1973-1981. Publ No. 85-1837, Bethesda, MD.
- Usenko VS, Lepekhin EA, Kornilovska IN, et al. 1998. Immunohistochemical study of fibronectin and thyroglobulin in the thyroid gland of female rats after exposure to radioactive iodine. *Anat Rec* 252:600-607.
- Usenko V, Lepekhin E, Lyzogubov V, et al. 1999. The influence of low doses ¹³¹I-induced maternal hypothyroidism on the development of rat embryos. *Exp Toxicol Pathol* 51:223-227.
- *USGS. 1984. Element concentrations in soils and other surficial materials of the conterminous United States. Washington, DC: United States Government Printing Office. U.S. Geological Survey Professional Paper 1270.
- *USGS. 1998. Iodine. USGS Minerals Information. <http://minerals.usgs.gov/minerals/pubs/commodity/iodine/index.html>.
- *USGS. 2001. Iodine. U.S. Geological Survey, Mineral Commodities Summaries. January 2001.
- Uy HL, Reasner CA, Samuels MH. 1995. Pattern of recovery of the hypothalamic-pituitary-thyroid axis following radioactive iodine therapy in patients with Graves' disease. *Am J Med* 99:173-179.
- *Uyttersprot N, Pelgrims N, Carrasco N, et al. 1997. Moderate doses of iodide in vivo inhibit cell proliferation and the expression of thyroperoxidase and Na⁺/I⁻ symporter mRNAs in dog thyroid. *Mol Cell Endocrinol* 131:195-203.
- Vadstrup S. 1989. Renal iodide clearance in rabbits. *Acta Endocrinol* 21:246-250.
- *Vadstrup S. 1993. Comparative aspects of iodine conservation in mammals. *Comp Biochem Physiol* 106A(1):15-17.
- Vagenakis A, Abreau C, Braverman L. 1971a. Effect of tracer doses of ¹³¹I on serum protein bound iodine and serum thyroxine concentration. *J Nucl Med* 12:637-638.
- Vagenakis AG, Braverman LE, Foster AE, et al. 1971b. Stimulatory effect of 5-fluorouracil in thyroid/serum iodide concentration ratios in the rat. *Endocrinology* 88:1250-1252.

9. REFERENCES

- Vagenakis AG, Downs P, Braverman LE, et al. 1973. Control of thyroid hormone secretion in normal subjects receiving iodides. *J Clin Invest* 52:528-532.
- *Vagenakis AG, Wang C-A, Burger A, et al. 1972. Iodide-induced thyrotoxicosis in Boston. *N Engl J Med* 287(11):523-527.
- Valenta LJ. 1974. Effect of iodide and thyrotrophin on in vitro ¹⁴C-amino acid incorporation into rat thyroid proteins. *Acta Endocrinol* 76:273-285.
- van Best JA. 1981. Dose calculations for ¹²³I, ¹²⁴I, ¹²⁵I and ¹³¹I in the thyroid gland of the mouse, rat and man and comparison with thyroid function for mice and rats. *Phys Med Biol* 26(6):1035-1053.
- Van Best JA. 1982. Comparison of thyroid function in mice after various injected activities of ¹²³I, ¹²⁵I and ¹³¹I. *Int J Radiat Biol* 42(5):545-557.
- Vandenbroucke MF, Herveg JP, Beckers C, et al. 1967. Iodide uptake studies on isolated thyroid cells. *Arch Int Physiol Biochim* 75(1):185-186.
- van den Hove MF, Beckers C, Devlieger H, et al. 1999. Hormone synthesis and storage in the thyroid of human preterm and term newborns: Effect of thyroxine treatment. *Biochimie* 81:563-570.
- van der Heyden JTM, Docter R, van Toor H, et al. 1986. Effects of caloric deprivation on thyroid hormone tissue uptake and generation of low-T₃ syndrome. *Am J Physiol* 251(14):E156-E163.
- *Vanderpas JB, Contempre B, Duale NL et al. 1990. Iodine and selenium deficiency associated with cretinism in Northern Zaire. *Am. J. Clin. Nutr.* 52:1087-1093.
- *Vanderpump MPJ, Tunbridge WMG. 2000. The epidemiology of thyroid diseases. In: Braverman LE, Utiger RD, eds. *Werner and Ingbar's the thyroid: A fundamental and clinical text*. 8th ed. Philadelphia, PA: Lippincott-Raven, 474-482.
- Vanderpump MPJ, Ahlquist JAO, Franklyn JA, et al. 1996. Consensus statement for good practice and audit measures in the management of hypothyroidism and hyperthyroidism. *Br Med J* 313:539-544.
- Van Der Willigen AH, Habets JMW, Van Joost T, et al. 1988. Contact allergy to Japanese sargassum. *Contact Dermatitis* 18(4):250-252.
- *Van Dilla MA, Fulwyler MJ. 1963. Thyroid metabolism in children and adults using very small (nanocurie) doses of iodine¹²⁵ and iodine¹³¹. *Health Phys* 9:1325-1331.
- *Van Dilla MA, Fulwyler MJ. 1964. Radioiodine metabolisms in children and adults after the ingestion of very small doses. *Science* 144:178-179.
- Van Herle AJ, Van Herle KA. 1997. Thyroglobulin in benign and malignant thyroid disease. In: Falk SA, ed. *Thyroid disease: Endocrinology, surgery, nuclear medicine, and radiotherapy*. Philadelphia, PA: Lippincott-Raven Publishers, 587-599.
- Van Middlesworth I. 1971. Persistence of ¹²⁵I in thyroid. *N Engl J Med* 286(3):161.
- *Van Middlesworth L. 1954. Radioactive iodide uptake of normal newborn infants. *Am J Dis Child* 88:439-442.
- *Van Middlesworth L. 1993. ¹²⁹I and ¹³⁷Cs fission products in thyroids of animals, 1984-1991. *Health Phys* 64(1):52-58.

9. REFERENCES

- Van Nostrand D, Neutze J, Atkins F. 1986. Side effects of "rational dose" iodine-131 therapy for metastatic well-differentiated thyroid carcinoma. *J Nucl Med* 27:1519-1527.
- Van Sande J, Dumont JE. 1973. Effects of thyrotropin, prostaglandin E1 and iodide on cyclic 3',5'-AMP concentration in dog thyroid slices. *Biochim Biophys Acta* 313:320-328.
- Van Sande J, Cochaux P, Mockel J, et al. 1983. Stimulation by forskolin of the thyroid adenylate cyclase, cyclic AMP accumulation and iodine metabolism. *Mol Cell Endocrinol* 29:109-119.
- Van Sande J, Deneubourg F, Beauwens R, et al. 1990. Inhibition of iodide transport in thyroid cells by dysidenin, a marine toxin, and some of its analogs. *Mol Pharmacol* 37:583-589.
- Van Sande J, Erneux C, Dumont JE. 1977. Negative control of TSH action by iodide and acetylcholine: Mechanism of action in intact thyroid cells. *J Cyclic Nucleotide Res* 3:335-345.
- Van Sande J, Grenier G, Willems C, et al. 1975. Inhibition by iodide of the activation of the thyroid cyclic 3',5'-AMP system. *Endocrinology* 96:781-786.
- Van Wyngaarden M, McDougall IR. 1996. What is the role of 1100 MBq (<30 mCi) radioiodine ¹³¹I in the treatment of patients with differentiated thyroid cancer. *Nucl Med Commun* 17:199-207.
- *Vargo GJ. 2000. *The Chernobyl accident: A comprehensive risk assessment*. Columbus, OH: Battelle Press.
- Varma SK, Murray R, Stanbury JB. 1978. Effect of maternal hypothyroidism and triiodothyronine on the fetus and newborn in rats. *Endocrinology* 102(1):24-30.
- Varma VM, Beierwaltes WH, Nofal MM, et al. 1970. Treatment of thyroid cancer: Death rates after surgery and after surgery followed by sodium iodide I 131. *JAMA* 214(8):1437-1442.
- Varrone S, Consiglio E, Covelli I. 1970. The nature of inhibition of mitochondrial malate dehydrogenase by thyroxine, iodine cyanide and molecular iodine. *Eur J Biochem* 13:305-312.
- Vasilenko IY. 1980. Iodine isotopes in radiation hygiene. *J Hyg Epidemiol Microbiol Immunol* 24(2):142-149.
- *Vasilenko IY. 1986. A radiation-hygienic appraisal of biosphere contamination with ¹²⁹I. *J Hyg Epidemiol Microbiol Immunol* 30:243-248.
- Vassilopoulou-Sellin R, Sellin JH. 1996a. The gastrointestinal tract and liver in hypothyroidism. In: Braverman LE, Utiger RD, eds. *Werner and Ingbar's the thyroid: A fundamental and clinical text*. Philadelphia, PA: Lippincott-Raven, 816-820.
- Vassilopoulou-Sellin R, Sellin JH. 1996b. The gastrointestinal tract and liver in thyrotoxicosis. In: Braverman LE, Utiger RD, eds. *Werner and Ingbar's the thyroid: A fundamental and clinical text*. Philadelphia, PA: Lippincott-Raven, 632-636.
- Vatulina GG. 1977. [Metabolic changes in rat muscle tissue under separate and combined exposure to Iodine 131 and Strontium 89.] *Radiobiologiya* 17(5):728-732. (Russian)
- Vejjjajiva S, Poshyachinda M, Yenbutra D. 1979. ¹³¹I treated hypothyroidism and thyroid antibody levels. *J Med Assoc Thai* 62(2):51-53.
- Veldhuis JD. 1978. ¹³¹I-induced hypothyroidism before recurrence of hyperthyroidism. *Lancet* 1(8071):993-994.

9. REFERENCES

- Velkeniers B, Cytryn R, Vanhaelst I, et al. 1988. Treatment of hyperthyroidism with radioiodine: Adjunctive therapy with antithyroid drugs reconsidered. *Lancet* 1:1127-1129.
- Venderpas JB, Rivera-Vanderpas MT, Bourdoux P, et al. 1986. Reversibility of severe hypothyroidism with supplementary iodine in patients with endemic cretinism. *N Engl J Med* 315(13):791-795.
- Venkataraman GM, Yatin M, Ain KB. 1998. Cloning of the human sodium-iodide symporter promoter and characterization in a differentiated human thyroid cell line, KAT-50. *Thyroid* 8(1):63-69.
- *Verma S, Hutchins P, Guo J et al. 2000. Role of MHC class I expression and CD8⁺ T cells in the evolution of iodine-induced thyroiditis in NOHh2^{h4} and NOS mice. *Eur J Immunol* 30:1191-1202.
- *Verma KK, Jain A, Verma A. 1992. Determination of iodide by high-performance liquid chromatography after precolumn derivatization. *Anal Chem* 64:1484-1489.
- Versloot PM, Schroder-van der Elst JP, van der Heide D, et al. 1998. Effects of marginal iodine deficiency on thyroid hormone production, distribution and transport in nonpregnant and near-term pregnant rats. *Eur J Endocrinol* 138:713-718.
- Vestergaard H, Laurberg P. 1989. Radioiodine and aggravation of Graves' ophthalmopathy. *Lancet* 2(8653):47.
- Vetter RJ. 1997. Regulations for radioiodine therapy in the United States: Current status and the process of change. *Thyroid* 7(2):209-211.
- *Vicens-Calvet E, Potau N, Carreras E, et al. 1998. Diagnosis and treatment in utero of goiter with hypothyroidism caused by iodide overload. *J Pediatr* 133:147-148.
- Vickery ALJ, Williams ED. 1971. Comparative biological effects of ¹²⁵I and ¹³¹I on the rat thyroid. *Acta Endocrinol* 66:201-212.
- *Vieira I, Sonnier M, Cresteil T. 1996. Developmental expression of *CYP2E1* in the human liver: Hypermethylation control of gene expression during the neonatal period. *Eur J Biochem* 238:476-483.
- Vieira JGH, Brandao CMA, Kasamatsu TS, et al. 1991. Parathyroid hormone secretory reserve in patients submitted to 131-iodine therapy for hyperthyroidism. *Braz J Med Biol Res* 24:1103-1105.
- Vilijn F, Carrasco N. 1989. Expression of the thyroid sodium/iodide symporter in *xenopus laevis* oocytes. *J Biol Chem* 264(20):11901-11903.
- Villa SM, Alexander NM. 1987. Carbamazepine (Tegretol) inhibits in vivo iodide uptake and hormone synthesis in rat thyroid glands. *Endocr Res* 13(4):385-397.
- *Virion A, Deme D, Pommier J, et al. 1980. Opposite effects of thiocyanate on tyrosine iodination and thyroid hormone synthesis. *Eur. J. Biochem.* 112:1-7.
- *Visser TJ. 1990. Importance of deiodination and conjugation in the hepatic metabolism of thyroid hormone. In: Greer MA, ed. *The thyroid gland*. New York, NY: Raven Press, Ltd, 255-283.
- *Visser TJ. 1994. Role of sulfation in thyroid hormone metabolism. *Chem Biol Interact* 92:293-303.
- *Visser TJ, Kaptein E, van Raaij JAGM, et al. 1993. Multiple UDP-glucuronyltransferases for the glucuronidation of thyroid hormone with preference for 3,3',5'-triiodothyronine (reverse T₃). *FEBS Lett* 315(1):65-68.

9. REFERENCES

- Vobecky M, Babicky A, Lener J, et al. 1997. [Environmental bromine and iodine interaction.] *Hygiena* 42(2):86-91. (Czech)
- *Vogt R, Sander R, Von Glasgow R, et al. 1999. Iodine chemistry and its role in halogen activation and ozone loss in the marine boundary layers: A model study. *J Atmos Chem* 32:375-395.
- Voigt G. 1993. Chemical methods to reduce the radioactive contamination of animals and their products in agricultural ecosystems. *Sci Total Environ* 137:205-225.
- *Voigt G, Henrichs K, Prohl G, et al. 1988. Measurements of transfer coefficients from ^{137}Cs , ^{60}Co , ^{54}Mn , ^{22}Na , ^{131}I and $^{95\text{m}}\text{Tc}$ from feed into milk and beef. *Radiat Environ Biophys* 27:143-152.
- *Voigt G, Muller H, Prohl G, et al. 1989. Experimental determination of transfer coefficients of ^{137}Cs and ^{131}I from fodder into milk of cows and sheep after the Chernobyl accident. *Health Phys* 57(6):967-973.
- Voigt G, Schotola C, Probstmeier G, et al. 1994. Influence of stable iodine on the transfer of ^{131}I into cows' milk. *Radiat Environ Biophys* 33:243-250.
- Volkov AA, Iulbarisov AV, Zaitsev VM, et al. 1982. [Use of sodium iodide labeled with short-lived ^{123}I for the study of the iodine absorption and topography of the thyroid.] *Med Radiol* 27(2):34-36. (Russian).
- Voltti H, Piha RS. 1978. Iodine in the treatment of alloxan diabetes in rats. *Isr J Med Sci* 14(10):1081-1083.
- Voltti H, Piha RS, Alavaikko M, et al. 1973. Antitumour activity of iodine in acidic medium with calcium. *Nature* 246:98-100.
- Von Hofe SE, Dorfman SG, Carretta RF, et al. 1978. The increasing incidence of hypothyroidism within one year after radioiodine therapy for toxic diffuse goiter. *J Nucl Med* 19:180-184.
- *Von Zallinger C, Tempel K. 1998. Transplacental transfer of radionuclides. A review. *Zentralbl Veterinarmed A* 45:581-590.
- Vorhees CV, Butcher RE, Brunner RL. 1984. Developmental toxicity and psychotoxicity of potassium iodide in rats: A case for the inclusion of behaviour in toxicological assessment. *Food Chem Toxicol* 22(12):963-970.
- Vorherr H, Vorherr UF, Mehta P, et al. 1980. Vaginal absorption of povidone-iodine. *JAMA* 244(23):2628-2629.
- Vormittag W, Ring F, Kunze-Muhl E, et al. 1982. Structural chromosomal aberrations before and after administration of 20 uCi iodine-131. *Mutat Res* 105:333-336.
- *Vought RL, Brown FA, Wolff J. 1972. Erythrosine: An adventitious source of iodide. *Journal of Clinical Endocrinology and Metabolism* 34:747-752.
- *Vroye L, Beauwens R, Van Sande J, et al. 1998. The Na^+-I^- cotransporter of the thyroid: Characterization of new inhibitors. *Pflugers Arch(Eur J Physiol)* 435:259-266.
- Vulsma T, Menzel D, Abbad FCB, et al. 1990. Iodine-induced hypothyroidism in infants treated with continuous cyclic peritoneal dialysis [Letter]. *Lancet* 336:812.
- Vulsma T, Rammeloo JA, Gons MH, et al. 1991. The role of serum thyroglobulin concentration and thyroid ultrasound imaging in the detection of iodide transport defects in infants. *Acta Endocrinol* 124:405-410.

9. REFERENCES

- Vykhovanets EV, Chernyshov VP, Slukvin II, et al. 1997. ^{131}I dose-dependent thyroid autoimmune disorders in children living around Chernobyl. *Clin Immunol Immunopathol* 84(3):251-259.
- Wachholz BW. 1990. Overview of the National Cancer Institute's activities related to exposure of the public to fallout from the Nevada test site. *Health Phys* 59(5):511-514.
- Wadeleux PA, Etienne-Decerf J, Winand RJ, et al. 1978. Effects of thyrotropin on iodine metabolism of dog thyroid cells in tissue culture. *Endocrinology* 102(3):889-902.
- Wagar G. 1971. Increase in thyroid uptake of radioiodine induced by actinomycin D. *Acta Endocrinol* 67:605-615.
- *Wagner HN, Nelp WB, Dowling JH. 1961. Use of neutron activation analysis for studying stable iodide uptake by the thyroid. *J Clin Invest* 40:1984-1992.
- Wahl VR, Oekonomopoulos R, Steiner B, et al. 1973. Einflub von diijofphenolsulfonsaure (DJPS) auf den jodstoffwechsel der ratte und auf die bindung von thyroxin an humanserumpraalbumin. *Arzneim Forsch* 23(8):1009-1014.
- Wahlberg P. 1976a. Thyrotoxicosis induced by iodine in food [Letter]. *Br Med J* 2(6043):1070.
- Wahlberg P. 1976b. Thyrotoxicosis induced by iodine in food [Letter]. *Br Med J* 1(6016):1016.
- Waldhausen JHT. 1997. Controversies related to the medical and surgical management of hyperthyroidism in children. *Semin Pediatr Surg* 6(3):121-127.
- Waldstein SS. 1997. Replacement and suppressive treatment with thyroid hormone. In: Falk SA, ed. *Thyroid disease: Endocrinology, surgery, nuclear medicine, and radiotherapy*. Philadelphia, PA: Lipponcott-Raven Publishers, 475-494.
- Walgraeve D, Verhoef G, Stul M, et al. 1991. Chronic myelogenous leukemia after treatment with ^{131}I for thyroid carcinoma: Report of a case and review of the literature. *Cancer Genet Cytogenet* 55:217-224.
- Walicka MA, Adelstein SJ, Kassis AI. 1998. Indirect mechanisms contribute to biological effects produced by decay of DNA-incorporated iodine-125 in mammalian cells *in vitro*: Clonogenic survival. *Radiat Res* 149:142-146.
- Walinder G. 1971. Determination of the ^{131}I dose to the mouse thyroid. *Acta Radiol Ther Phys Biol* 10:558-578.
- Walinder G. 1972. Quantitative effects of ^{131}I on different tissue components in foetal and goitrogen challenged mouse thyroids. *Acta Radiol* 11:1-23.
- Walinder G, Feinstein RE, Gimeno EJ. 1986. Effect of high ^{131}I doses on the bone uptake and retention of ^{90}Sr and ^{90}Y . *Acta Radiol Oncol* 25:255-260.
- Walls RP. 1976. The characteristics and physiologic implications of the interaction of iodide with human erythrocytes. *Diss Abstr Int B* 36(11):5542-B.
- *Walser M, Rahill WJ. 1965. Renal tubular reabsorption of iodide as compared with chloride. *J Clin Invest* 44(8):1371-1381.
- Walsh JP, Dayan CM, Potts MJ. 1999. Radioiodine and thyroid eye disease. *Br Med J* 319:68-69.
- Walthard VB. 1963. [Structural change of the struma maligna with respect to iodine prophylaxis of goiter.] *Schweiz Med Wochenschr* 93(23):809-814. (German)

9. REFERENCES

- Wang JF, Becks GP, Hanada E, et al. 1991. Hormonal regulation of insulin-like growth factor (IGF)-binding proteins secreted by isolated sheep thyroid epithelial cells: Relationship with iodine organification. *J Endocrinol* 130:129-140.
- Wang J-X, Boice JD, Li B-X, et al. 1988. Cancer among medical diagnostic x-ray workers in China. *Journal of the National Cancer Institute* 80:344-350.
- Wang Z, Boice JD, Wei L, et al. 1990. Thyroid nodularity and chromosome aberrations among women in areas of high background radiation in China. *J Natl Cancer Inst* 82:478-485.
- *Waran KD, Munsick RA. 1995. Anaphylaxis from povidone-iodine. *Lancet* 345:1506.
- Warner TFCS. 1979. Iodine-131 and malignancy [Letter]. *Lancet* 1(8106):38.
- Warters RL. 1977. 125-Iodine: A probe in radiobiology [Abstract]. *Diss Abstr Int B* 38(4):1598B.
- Warters RL, Hofer KG. 1977. Radionuclide toxicity in cultured mammalian cells: Elucidation of the primary site for radiation-induced division delay. *Radiat Res* 69:348-358.
- Warters RL, Hofer KG, Harris CR, et al. 1977. Radionuclide toxicity in cultured mammalian cells: Elucidation of the primary site of radiation damage. *Curr Top Radiat Res Q* 12:389-407.
- Wartofsky L. 1995. Summation, commentary, and overview: Concerns over aggravation of Graves' ophthalmopathy by radioactive iodine treatment and the use of retrobulbar radiation therapy. *J Clin Endocrinol Metab* 80(2):347-349.
- Wartofsky L. 1996a. Myxedema coma. In: Braverman LE, Utiger RD, eds. *Werner and Ingbar's the thyroid: A fundamental and clinical text*. Philadelphia, PA: Lippincott-Raven, 871-877.
- Wartofsky L. 1996b. Thyrotoxic storm. In: Braverman LE, Utiger RD, eds. *Werner and Ingbar's the thyroid: A fundamental and clinical text*. Philadelphia, PA: Lippincott-Raven, 701-707.
- Wartofsky L. 1997. Radioiodine therapy for Graves' disease: Case selection and restrictions recommended to patients in North America. *Thyroid* 7(2):213-216.
- Wasserman HJ, Klopper JF. 1993. Analysis of radiation doses received by the public from ¹³¹I treatment of thyrotoxic outpatients. *Nucl Med Commun* 14:756-760.
- Wasserman J, Blomgren H, Petrini B, et al. 1988. Changes of the blood lymphocyte subpopulations and their functions following ¹³¹I treatment for nodular goitre and ³²P treatment for polycythemia vera. *Int J Radiat Biol* 53(1):159-167.
- Wassermann M, Wassermann D, Kedar E, et al. 1972. Effects of dieldrin and gamma BHC on serum proteins and PBI. *Bull Environ Contam Toxicol* 8(3):177-185.
- Watanabe N, Yokoyama K, Kinuya S, et al. 1998. Radiotoxicity after iodine-131 therapy for thyroid cancer using the micronucleus assay. *J Nucl Med* 39(3):436-440.
- Waterfall WK. 1980. Iodide. *Br Med J* 281:988-989.
- Waters W, Kutsim H, Wellner U. 1984. The influence of elevated iodide supply on the autonomously functioning thyroid gland. *Nuklearmedizin* 23:93-99.
- Watson AB, Brownlie BEW, Frampton CM, et al. 1988. Outcome following standardized 185 MBq dose ¹³¹I therapy for Graves' disease. *Clin Endocrinol* 28:487-496.

9. REFERENCES

*Wayne EJ, Koutras DA, Alexander WD. 1964. Clinical aspects of iodine metabolism. Philadelphia, PA: F.A. Davis Company.

Weber G, Vigone MC, Rapa A, et al. 1998. Neonatal transient hypothyroidism: Aetiological study. *Arch Dis Child* 79:F70-F72.

*Weetman AP. 2000. Chronic autoimmune thyroiditis. In: Braverman LE, Utiger RD, eds. *Werner and Ingbar's the thyroid: A fundamental and clinical text*. 8th ed. Philadelphia, PA: Lippincott-Raven, 721-732.

*Wehmann G. 1963. Comparison of ingestion to inhalation dose to man from I¹³¹. *Health Physics* 9:1221.

Weinberg HG, Yamada H. 1997. Sub part-per-billion analysis of bromate, iodate, and chlorite in drinking water using a new post ion chromatography column reaction and UV detection. In: *Water quality technology conference proceedings, November 9-12, 1997, Denver, Co., 4B1/1-4B1/13*.

Weinreich R. 1984. Iodine-124 in nuclear medicine: A critical evaluation. *Radiakt Isot Klin Forsch* 16(2):555-563.

*Weiss SJ, Philp NJ, Ambesi-Impiombato FS, et al. 1984b. Thyrotropin-stimulated iodide transport mediated by adenosine 3',5'-monophosphate and dependent on protein synthesis. *Endocrinology* 114(4):1099-1107.

*Weiss SJ, Philip NJ, Grollman EF. 1984a. Effect of thyrotropin on iodide efflux in FRTL-5 cells mediated by Ca²⁺. *Endocrinology* 114:1108-1113.

Weiss WJ, Philp NJ, Grollman EF. 1984c. Iodide transport in a continuous line of cultured cells from rat thyroid. *Endocrinology* 114:1090-1098.

*Wellner U, Eschner W, Hillger HW, et al. 1998. [The exposure of relatives to patients of a nuclear medicine ward after radio iodine therapy by inhalation of ¹³¹I in their home.] *Nuklearmedizin* 37:113-119. [Erratum published in "*Nuklearmedizin* 37(4):49 (1998)" attached] (German)

Werner SC, Hamilton HB, Leifer E, et al. 1950. An appraisal of the radioiodine tracer technic as a clinical procedure in the diagnosis of thyroid disorders: Uptake measurement directly over the gland and a note on the use of thyrotropin (T.S.H.). *J Clin Endocrinol* 10:1054-1076.

*West JR, Smith HW, Chasis H. 1948. Glomerular filtration rate, effective renal blood flow, and maximal tubular excretory capacity in infancy. *J Pediatr* 32:10-18.

Whaley JM, Little JB. 1990. Efficient mutation induction by ¹²⁵I and ¹³¹I decays in DNA of human cells. *Radiat Res* 123:68-74.

*Whitehead DC. 1979. Iodine in the U.K. environment with particular reference to agriculture. *J Appl Ecol* 16:269-279.

*Whitehead DC. 1984. The distribution and transformations of iodine in the environment. *Environ Int* 10:321-339.

*Whitnack GC. 1975. Single-sweep polarographic techniques useful in micropollution studies of ground and surface waters. *Anal Chem* 47:618-621.

Whybrow PC. 1972. Synergistic action between iodine and lithium [Letter]. *JAMA* 221(5):506.

9. REFERENCES

- Whybrow PC. 1996a. Behavioral and psychiatric aspects of hypothyroidism. In: Braverman LE, Utiger RD, eds. *Werner and Ingbar's the thyroid: A fundamental and clinical text*. Philadelphia, PA: Lippincott-Raven, 866-870.
- Whybrow PC. 1996b. Behavioral and psychiatric aspects of thyrotoxicosis. In: Braverman LE, Utiger RD, eds. *Werner and Ingbar's the thyroid: A fundamental and clinical text*. Philadelphia, PA: Lippincott-Raven, 696-700.
- *Widdowson EM, Dickerson JWT. 1964. Chemical composition of the body. In: Comar CL, Bronner F, eds. *Mineral metabolism: An advanced treatise*. Volume II: The elements Part A. New York: Academic Press.
- Wiener JD, Thijs LG, Meijer S. 1975. Thyroid carcinoma after ^{131}I treatment for hyperthyroidism. *Acta Med Scand* 198:329-330.
- Wiersinga WM. 1998. Preventing Graves' ophthalmopathy. *N Engl J Med* 338(2):121-122.
- Wiesenfeld D, Webster G, Cameron F, et al. 1983. Salivary gland dysfunction following radioactive iodine therapy. *Oral Surg Oral Med Oral Pathol* 55(2):138-141.
- Wilkin JK, Strobel D. 1985. Iododerma occurring during thyroid protection treatment. *Cutis* 36(4):335-337.
- *Willard DH, Bair WJ. 1961. Behaviour of I^{131} following its inhalation as a vapour and as a particle. *Acta Radiol* 55:486-496.
- Williams ED. 1990. TSH and thyroid cancer. *Horm Metab Res suppl* 23:72-75.
- Williams ED, Doniach I, Bjarnason O, et al. 1977. Thyroid cancer in an iodide rich area. *Cancer* 39:215-222.
- *Williams JA. 1969. Electrical polarization of thyroid follicles in the perfused rabbit thyroid gland. *Am J Physiol* 217(4):1094-1100.
- Williams JA, Malayan SA. 1975. Effects of TSH on iodide transport by mouse thyroid lobes *in vitro*. *Endocrinology* 97:162-168.
- Williams JA, Berens SC, Wolff J. 1971. Thyroid secretion *in vitro*: Inhibition of TSH and dibutyryl cyclic-AMP stimulated and ^{131}I release by Li^+ . *Endocrinology* 88:1385-1388.
- Williams RL, Lipari F, Potter RA. 1990. Formaldehyde, methanol and hydrocarbon emissions from methanol-fueled cars. *J Air Waste Manage Assoc* 40:747-756.
- Wilmott S, Nair S, Ponting AC. 1991. An uncertainty analysis of the ingestion dose following a discrete deposition from atmosphere. *EUR EUR* 13013/2:891-907.
- Wilson LM, Barrington SF, Morrison ID, et al. 1998. Therapeutic implications of thymic uptake of radioiodine in thyroid carcinoma. *Eur J Nucl Med* 25:622-628.
- Wilson MG. 1962. The effect of maternal medications upon the fetus and the newborn infant. *Am J Obstet Gynecol* 83(6):818-825.
- Wilson O, Stone JM, Monty DE. 1983. Long-term study of thyroid function in healthy beagle dogs, using ^{125}I . *Am J Vet Res* 44(7):1392-1398.

9. REFERENCES

- Wingert DJ, Friesen SR, Iliopoulos JI, et al. 1986. Post-thyroidectomy hypocalcemia. *Am J Surg* 152:606-610.
- Winslow CP, Meyers AD. 1998. Hypocalcemia as a complication of radioiodine therapy. *Am J Otolaryngol* 19(6):401-403.
- Winternitz SR, Winternitz WW. 1976. Fatal hypothyroidism following treatment of Graves' disease: A preventable complication. *J Ky Med Assoc* 74(9):459-460.
- Winters JC, Fuselier HAJ. 1992. Invasive bladder cancer following ¹²⁵I iodine implants. *J Urol* 148:1898-1900.
- Wiseman JC, Hales IB, Joasoo A. 1982. Two cases of lymphoma of the parotid gland following ablative radioiodine therapy for thyroid carcinoma. *Clin Endocrinol* 17:85-89.
- Wiszniewska B, Marchlewicz M, Piasecka M, et al. 1998. Phospholipid content and lamellar structures in the epididymal epithelial cells of rats treated chronically with lead acetate [Pb(II)]. *Folia Biol* 46:215-224.
- Wolf M, Leventon G. 1990. Acute iodide-induced enlargement of the salivary glands. *J Oral Maxillofac Surg* 48:71-72.
- *Wolff J. 1964. Transport of iodide and other anions in the thyroid gland. *Physiol Rev* 44:45-90.
- Wolff J. 1980. Physiological aspects of iodide excess in relation to radiation protection. *J Mol Med* 4:151-165.
- *Wolff J. 1983. Congenital goiter with defective iodide transport. *Endocrine Rev* 4(3):240-254.
- Wolff J. 1989. Excess iodide inhibits the thyroid by multiple mechanisms. *Adv Exp Med Biol* 261:211-244.
- Wolff J. 1996. Iodide prophylaxis for reactor accidents. In: Nagataki S, Yamashita S, eds. *Nagasaki symposium radiation and human health*. Amsterdam, the Netherlands: Elsevier Science, 227-237.
- *Wolff J, Chaikoff IL. 1948. Plasma inorganic iodide as a homeostatic regulator of thyroid function. *J. Biol. Chem.* 174:555-564.
- *Wolff J, Chaikoff IL, Goldberg RC, et al. 1949. The temporary nature of the inhibitory action of excess iodide on organic iodine synthesis in the normal thyroid. *Endocrinol.* 45:504-513.
- Wollman SH. 1995. Thyroid radioiodide transport: Models, rate-limiting steps, and relation to formation of iodoprotein. *Eur J Cell Biol* 66:217-225.
- Wollman SH, Reed FE. 1959. Transport of radioiodide between thyroid gland and blood in mice and rats. *Am J Physiol* 196(1):113-120.
- Wondisford FE, Magner JA, Weintraub BD. 1996. Thyrotropin: Chemistry and biosynthesis of thyrotropin. In: Braverman LE, Utiger RD, eds. *Werner and Ingbar's the thyroid: A fundamental and clinical text*. Philadelphia, PA: Lippincott-Raven, 190-207.
- *Wong FL, Ron E, Gierlowski T, et al. 1996. Benign thyroid tumors: General risk factors and their effects on radiation risk estimation. *Am. J. Epidemiol.* 144:728-733.
- *Wong GTF, Cheng X-H. 1998. Dissolved organic iodine in marine waters: Determination, occurrence and analytical implications. *Mar Chem* 59:271-281.

9. REFERENCES

- Wongphatarakul V, Friedlander SK, Pinto JP. 1998. A comparative study of PM_{2.5} ambient aerosol chemical databases. *Environ Sci Technol* 32:3926-3934.
- *Wood DH, Elefson EE, Horstman VG, et al. 1963. Thyroid uptake of radioiodine following various routes of administration. *Health Phys* 9:1217-1220.
- *Woodbury DM, Woodbury JW. 1963. Correlation of micro-electrode potential recordings with histology of rat and guinea-pig thyroid glands. *J Physiol* 169:553-567.
- Woolf PD. 1997. Thyroiditis. In: Falk SA, ed. *Thyroid disease: Endocrinology, surgery, nuclear medicine, and radiotherapy*. Philadelphia, PA: Lippincott-Raven Publishers, 393-410.
- Worley RJ, Crosby WM. 1974. Hyperthyroidism during pregnancy. *Am J Obstet Gynecol* 119(2):150-155.
- Worthington-Roberts B. 1997. The role of maternal nutrition in the prevention of birth defects. *J Am Diet Assoc* 97(Suppl 2):S184-S185.
- Wright EM. 1974. Active transport of iodide and other anions across the choroid plexus. *J Physiol* 240:535-566.
- Wuttke K, Streffer C, Muller WU, et al. 1996. Micronuclei in lymphocytes of children from the vicinity of Chernobyl before and after ¹³¹I therapy for thyroid cancer. *Int J Radiat Biol* 69(2):259-268.
- Wyburn JR. 1972. Human breast milk excretion of radionuclides following administration of radiopharmaceuticals. *J Nucl Med* 14(2):115-117.
- Xiangbao L, Yangzhong X. 1992. Relationship between ¹³¹I ground surface contamination activity and gamma spectra above ground. *Health Phys* 62(4):328-331.
- Yadav HS, Chaudhuri BN, Mukherjee SK. 1970. Effect of ethyl alcohol on thyroidal iodide trapping and renal clearance of ¹³¹I label in rats. *Indian J Med Res* 58:1421-1427.
- Yalow RS. 1983. Risks in mass distribution of potassium iodide. *Bull N Y Acad Med* 59(10):1020-1027.
- Yalow R. 1990. Editorial: The contributions of ¹³¹I to the understanding of radiation carcinogenesis. *Endocrinology* 126(4):1787-1789.
- Yamamoto K, Onaya T, Yamada T, et al. 1972. Inhibitory effect of excess iodide on thyroid hormone release as measured by intracellular colloid droplets. *Endocrinology* 90:986-991.
- Yamane T, Yan Y, Yang L, et al. 1992. Tissue developmental anomalies of Corti's organ of the inner ear in experimental cretin rats [Abstract]. *Teratology* 46(6):44B.
- Yamashita H, Noguchi S, Murakami N, et al. 1994. Effect of thyroid-stimulating hormone on cultured thyrocytes obtained from patients with Graves' disease and inhibitive effect by sodium iodide: A functional study. *Pathol Int* 44:827-831.
- Yamashita K, Aiyoshi Y, Oka K, et al. 1975. Effects of calcium ionophore (A-23187) on glucose oxidation and iodide transport in dog thyroid slices. *Endocrinol Jpn* 22(5):415-418.
- Yamashita S, Ito M, Namba H, et al. 1996. Screening for childhood thyroid diseases around Chernobyl. In: Nagasaki S, Yamashita S, eds. *Nagasaki symposium radiation and human health: Proposal from Nagasaki*. Amsterdam, the Netherlands: Elsevier, 103-116.

9. REFERENCES

- Yan T, Wang D, Zhang H, et al. 1994. Effect of iodine deficiency on the development of cerebral cells in rats. *Teratology* 50(6):49B.
- Yan Y, Liu J, Yamane T, et al. 1993. Developmental anomalies of cerebellar cortex in experimental cretin rats [Abstract]. *Teratology* 48(5):531.
- Yang CM, Olsen KR, Schwade JG, et al. 1993. Dose rate effect of ^{125}I irradiation on normal rabbit eyes and experimental choroidal melanoma. *Exp Eye Res* 57:577-585.
- Yasui LS. 1992. Cytotoxicity of ^{125}I decay in the DNA double strand break repair deficient mutant cell line, xrs-5. *Int J Radiat Biol* 62(5):613-618.
- Yasui LS, Hofer KG. 1986. Role of mitochondrial DNA in cell death induced by ^{125}I decay. *Int J Radiat Biol* 49(4):601-610.
- Yeh SDJ, La Quaglia MP. 1997. ^{131}I therapy for pediatric thyroid cancer. *Semin Pediatr Surg* 6(3):128-133.
- Yi T. 1995. A case of blindness caused by acute iodine poisoning. *Chin Med J* 108(7):555-556.
- Yokoyama N, Tominaga T, Eishima K, et al. 1991. Effect of iodide on human thyroid peroxidase in thyroid cells. In: Gordon A, Gross J, Hennemann G, eds. *Progress in thyroid research*. Rotterdam, the Netherlands: Balkema, 483-485.
- Yoosufani Z, Slavin JD, Hellman RM, et al. 1987. Preleukemia following large dose radioiodide therapy for metastatic thyroid carcinoma. *J Nucl Med* 28:1348-1350.
- *Yoshida A, Sasaki N, Mori A, et al. 1997. Different electrophysiological character of I^- , ClO_4^- , and SCN^- in the transport by NA^+/I^- symporter. *Biochem Biophys Res Commun* 231:731-734.
- Yoshida K, Aizawa Y, Kaise N, et al. 1998. Role of thyroid-stimulating blocking antibody in patients who developed hypothyroidism with one year after ^{131}I treatment for Graves' disease. *Clin Endocrinol* 48:17-22.
- Yoshimura S, Shishiba Y, Shimizu T. 1973. Evidence for stimulation of thyroidal secretion by iodoaminoacids or iodide. *Endocrinol Jpn* 20(2):217-219.
- Yoshinari M, Tokuyama T, Okamura K, et al. 1988. Iodide-induced thyrotoxicosis in a thyroidectomized patient with metastatic thyroid carcinoma. *Cancer* 61:1674-1678.
- *Young WF. 1990. Human liver tyrosylsulfotransferase. *Gastroenterology* 99:1072-1078.
- *Yuita K. 1994a. Overview and dynamics of iodine and bromine in the environment: 1. Dynamics and iodine and bromine in soil-plant system. *JARQ* 28:90-99.
- Yuita K. 1994b. Overview and dynamics of iodine and bromine in the environment: 2. Iodine and bromine toxicity and environmental hazards. *JARQ* 28:100-111.
- Yukimura Y, Ikejiri K, Kojima A, et al. 1976. Effects of excess iodide and other anions on thyroid hormone secretion in normal or hypophysectomized rats treated with graded doses of thyroid hormone. *Endocrinology* 99:541-548.
- Zagrodzki P, Nicol F, McCoy MA, et al. 1998. Iodine deficiency in cattle: Compensatory changes in thyroidal selenoenzymes. *Res Vet Sci* 64(3):209-211.

9. REFERENCES

- Zanzonico PB. 1997. Radiation dose to patients and relatives incident to ^{131}I therapy. *Thyroid* 7(2):199-204.
- Zanzonico PB, Becker DV, Bigler RE, et al. 1987. Fetal radiation dosimetry for maternally administered ^{131}I -iodide: Effect of maternal thyroid function. *J Nucl Med* 28(4):581.
- Zec N, Donovan JW. 1993. Reply to letter. *N Engl J Med* 328(5):356.
- Zeighami EA, Morris MD. 1986. Thyroid cancer risk in the population around the Nevada test site. *Health Phys* 50(1):19-32.
- *Zemlyn S, Wilson WW, Hellweg PA. 1981. A caution on iodine water purification. *West J Med* 135:166-167.
- Zhang M-L, Sugawa H, Mori T. 1995. Inhibition of thyrocyte iodide uptake by $\text{H}^+\text{K}^+\text{ATPase}$ inhibitor, timoprazole. *Endocr J (Tokyo)* 42(4):489-496.
- Zhao W, Zhu H, Yu Z, et al. 1998. Long-term effects of various iodine and fluorine doses on the thyroid and fluorosis in mice. *Endocr Regul* 32:63-70.
- Zhorno LI, Il'in BN, Mikhaidarova PP. 1982. [Morphofunctional changes in the thyroid after separate and combined exposure to iodine radioisotope.] *Radiobiologiya* 22(4):553-556. (Russian)
- Zhu X, Lu T, Song X, et al. 1984. Endemic goiter due to iodine rich salt and its pickled vegetables. *Chin Med J* 97(7):545-548.
- *Ziegler EE, Edwards BB, Jensen RL, et al. 1978. Absorption and retention of lead by infants. *Pediatr Res* 12:29-34.
- Zsebok Z, Baumgartner E. 1978. [Chromosomal changes following irradiation with small doses (author's translation).] *Fortschr Geb Rontgenstrahlen Nuklearmed Ergänzungsbd* 129(6):781-784. (German)
- Zuckier LS, Li Y, Chang CJ. 1998. Evaluation in a mouse model of a thyroid-blocking protocol for ^{131}I antibody therapy (short communication). *Cancer Biother Radiopharm* 13(6):457-460.
- Zuker CS, Cowman AF, Rubin GM. 1985. Isolation and structure of a rhodopsin gene from d. melanogaster. *Cell* 40:851-858.
- Zvonova IA. 1989. Dietary intake of stable I and some aspects of radioiodine dosimetry. *Health Phys* 57(3):471-475.
- Zvonova IA. 1996. The principles of radioiodine dosimetry following a nuclear accident. In: *Radiodosimetry and preventative measures in the event of a nuclear accident*. Austria: International Atomic Energy Agency, 15-33. IAEA-TECDOC-893.

10. GLOSSARY

Absorbed Dose, Chemical—The amount of a substance that is either absorbed into the body or placed in contact with the skin. For oral or inhalation routes, this is normally the product of the intake quantity and the uptake fraction divided by the body weight and, if appropriate, the time, expressed as mg/kg for a single intake or mg/kg/day for multiple intakes. For dermal exposure, this is the amount of material applied to the skin, and is normally divided by the body mass and expressed as mg/kg.

Absorbed Dose, Radiation—The mean energy imparted to the irradiated medium, per unit mass, by ionizing radiation. Units: rad (rad), gray (Gy).

Absorbed Fraction—A term used in internal dosimetry. It is that fraction of the photon energy (emitted within a specified volume of material) which is absorbed by the volume. The absorbed fraction depends on the source distribution, the photon energy, and the size, shape and composition of the volume.

Absorption—The process by which a chemical penetrates the exchange boundaries of an organism after contact, or the process by which radiation imparts some or all of its energy to any material through which it passes.

Absorption Coefficient—Fractional absorption of the energy of an unscattered beam of x- or gamma-radiation per unit thickness (linear absorption coefficient), per unit mass (mass absorption coefficient), or per atom (atomic absorption coefficient) of absorber, due to transfer of energy to the absorber. The total absorption coefficient is the sum of individual energy absorption processes (see Compton Effect, Photoelectric Effect, and Pair Production).

Absorption Coefficient, Linear—A factor expressing the fraction of a beam of x- or gamma radiation absorbed in a unit thickness of material. In the expression $I = I_0 e^{-\mu x}$, I_0 is the initial intensity, I the intensity of the beam after passage through a thickness of the material x , and μ is the linear absorption coefficient.

Absorption Coefficient, Mass—The linear absorption coefficient per cm divided by the density of the absorber in grams per cubic centimeter. It is frequently expressed as μ/ρ , where μ is the linear absorption coefficient and ρ the absorber density.

Absorption Ratio, Differential—Ratio of concentration of a nuclide in a given organ or tissue to the concentration that would be obtained if the same administered quantity of this nuclide were uniformly distributed throughout the body.

Activation—The process of making a material radioactive by bombardment with neutrons or protons.

Activity—The number of radioactive nuclear transformations occurring in a material per unit time (see Curie, Becquerel). The term for activity per unit mass is specific activity.

Activity Median Aerodynamic Diameter (AMAD)—The diameter of a unit-density sphere with the same terminal settling velocity in air as that of the aerosol particle whose activity is the median for the entire size distribution of the aerosol.

Acute Exposure, Chemical—Exposure to a chemical for a duration of 14 days or less, as specified in the Toxicological Profiles.

Acute Exposure, Radiation—The absorption of a relatively large amount of radiation (or intake of a radioactive material) over a short period of time.

Acute Radiation Syndrome—The symptoms which taken together characterize a person suffering from the effects of intense radiation. The effects occur within hours or days.

10. GLOSSARY

Ad libitum—Available in excess and freely accessible.

Adsorption Coefficient (K_{oc})—The ratio of the amount of a chemical adsorbed per unit surface area or per unit weight of organic carbon of a specific particle size in the soil or sediment to the concentration of the chemical in solution at equilibrium.

Adsorption Ratio (K_d)—See Distribution Coefficient

Alpha Particle—A positively charged particle ejected spontaneously from the nuclei of some radioactive elements. It is identical to a helium nucleus, i.e., 2 neutrons and two protons, with a mass number of 4 and an electrostatic charge of +2.

Alpha Track—The track of ionized atoms (pattern of ionization) left in a medium by an alpha particle that has traveled through the medium.

Annihilation (Positron-Electron)—An interaction between a positive and a negative electron in which they both disappear; their rest mass, being converted into electromagnetic radiation (called annihilation radiation) with two 0.51 MeV gamma photons emitted at an angle of 180° to each other.

Atom—The smallest particle of an element that cannot be divided or broken up by chemical means. It consists of a central core called the *nucleus*, which contains *protons* and *neutrons* and an outer shell of *electrons*.

Atomic Mass (u)—The mass of a neutral atom of a nuclide, usually expressed in terms of "atomic mass units." The "atomic mass unit" is one-twelfth the mass of one neutral atom of carbon-12; equivalent to 1.6604×10^{-24} g.

Atomic Number—The number of protons in the nucleus of an atom. The "effective atomic number" is calculated from the composition and atomic numbers of a compound or mixture. An element of this atomic number would interact with photons in the same way as the compound or mixture. (Symbol: Z).

Atomic Mass Number—See Mass Number.

Atomic Weight—The weighted mean of the masses of the neutral isotopes of an element expressed in atomic mass units.

Attenuation—A process by which a beam from a source of radiation is reduced in intensity by absorption and scattering when passing through some material.

Attenuation Coefficient—The fractional reduction in the intensity of a beam of radiation as it passes through an absorbing medium. It may be expressed as reduction per unit distance, per unit mass thickness, or per atom, and is called the linear, mass, or atomic attenuation coefficient, respectively.

Auger Effect—The emission of an electron from the extranuclear portion of an excited atom when the atom undergoes a transition to a less excited state.

Background Radiation—The amount of radiation to which a member of the general population is exposed from natural sources, such as terrestrial radiation from naturally occurring radionuclides in the soil, cosmic radiation originating from outer space, and naturally occurring radionuclides deposited in the human body.

Becquerel (Bq)—International System of Units unit of activity and equals that quantity of radioactive material in which one transformation (disintegration) occurs per second (see Units).

Beta Particle—An electron that is emitted from the nucleus of an atom during one type of radioactive transformation. A beta particle has a mass and charge equal in magnitude to that of the electron. The

10. GLOSSARY

charge may be either +1 or -1. Beta particles with +1 charges are called positrons (symbolized β^+), and beta particles with -1 charges are called negatrons (symbolized β^-).

Biological Half-time—The time required for a biological system, such as that of a human, to eliminate by natural process half of the amount of a substance (such as a chemical substance, either stable or radioactive) that has entered it.

Bioconcentration Factor (BCF)—The quotient of the concentration of a chemical in aquatic organisms at a specific time or during a discrete time period of exposure divided by the concentration in the surrounding water at the same time or during the same period.

Biologic Effectiveness of Radiation—See Relative Biological Effectiveness.

Biomarkers—Broadly defined as indicators signaling events in biologic systems or samples. They have been classified as markers of exposure, markers of effect, and markers of susceptibility.

Body Burden, Chemical—The total amount of a chemical found in an animal or human body.

Body Burden, Radioactivity—The amount of radioactive material found in an animal or human body.

Bone Seeker—Any compound or ion which migrates in the body and preferentially deposits into bone.

Branching—The occurrence of two or more modes by which a radionuclide can undergo radioactive decay. For example, ^{214}Bi can undergo alpha or beta minus decay, ^{64}Cu can undergo beta minus, beta plus, or electron capture decay. An individual atom of a nuclide exhibiting branching disintegrates by one mode only. The fraction disintegrating by a particular mode is the "branching fraction" for that mode. The "branching ratio" is the ratio of two specified branching fractions (also called multiple disintegration).

Bremsstrahlung—X rays that are produced when a charged particle accelerates (speeds up, slows down, or changes direction) in the strong field of a nucleus.

Buildup Factor—The ratio of the radiation intensity, including both primary and scattered radiation, to the intensity of the primary (unscattered) radiation.

Cancer Effect Level (CEL)—The lowest dose of chemical or radiation in a study, or group of studies, that produces significant increases in the incidence of cancer (or tumors) between the exposed population and its appropriate control.

Capture, Electron—A mode of radioactive decay involving the capture of an orbital electron by its nucleus. Capture from a particular electron shell, e.g., K or L shells, is designated as "K-electron capture" or "L-electron capture."

Capture, K-Electron—Electron capture from the K shell by the nucleus of the atom. Also loosely used to designate any orbital electron capture process.

Carcinogen—A chemical or radiation that is capable of inducing cancer.

Carcinoma—Malignant neoplasm composed of epithelial cells, regardless of their derivation.

Case-Control Study—A type of epidemiological study which examines the relationship between a particular outcome (disease or condition) and a variety of potential causative agents (such as toxic chemicals). In a case-controlled study, a group of people with a specified and well-defined outcome is identified and compared to a similar group of people without outcome.

Case Report—Describes a single individual with a particular disease or exposure. These may suggest some potential topics for scientific research but are not actual research studies.

10. GLOSSARY

Cataract—A clouding of the crystalline lens of the eye which obstructs the passage of light.

Ceiling Value—A concentration of a substance that should not be exceeded, even temporarily.

Charged Particle—A nuclear particle, atom, or molecule carrying a positive or negative charge.

Chronic Exposure—Exposure to a chemical for 365 days or more, as specified in the Toxicological Profiles.

Cohort Study—A type of epidemiological study of a specific group or groups of people who have had a common insult (e.g., exposure to an agent suspected of causing disease or a common disease) and are followed forward from exposure to outcome. At least one exposed group is compared to one unexposed group.

Collective dose—The sum of the individual doses received in a given period of time by a specified population from exposure to a specified source of radiation. Collective dose is expressed in units such as man-rem and person-sievert.

Compton Effect—An attenuation process observed for x- or gamma radiation in which an incident photon interacts with an orbital electron of an atom to produce a recoil electron and a scattered photon whose energy is less than the incident photon.

Containment—The confinement of a chemical or radioactive substance in such a way that it is prevented from being dispersed from its container or into the environment, or is released only at a specified rate.

Contamination—Deposition of a stable or radioactive substance in any place where it is not desired.

Cosmic Rays—High-energy particulate and electromagnetic radiations which originate outside the earth's atmosphere.

Count (Radiation Measurements)—The external indication of a radiation-measuring device designed to enumerate ionizing events. It refers to a single detected event. The term "count rate" refers to the total number registered in a given period of time. The term is sometimes erroneously used to designate a disintegration, ionizing event, or voltage pulse.

Counter, Gas-flow Proportional (GPC)— β -particles are detected by ionization of the counter gas which results in an electrical impulse at an anode wire. If a sufficient amount of radiostrontium is present and the ionization efficiency is calibrated, the quantity of radiostrontium can be determined.

Counter, Geiger-Mueller (GM counter)—Highly sensitive, gas-filled radiation-measuring device to detect (count) individual photons or particulate radiation.

Counter, Scintillation—The combination of phosphor, photomultiplier tube, and associated circuits for counting light emissions produced in the phosphors by ionizing radiation. Scintillation counters generally are more sensitive than GM counters for gamma radiation.

Counting, Cerenkov—Relatively energetic β -particles pass through a transparent medium of high refractive index and a highly-directional, bluish-white light ("Cerenkov" light) is emitted. This light is detected using liquid scintillation counting equipment.

Cross-sectional Study—A type of epidemiological study of a group or groups which examines the relationship between exposure and outcome to a chemical or to chemicals at one point in time.

Curie (Ci)—A unit of radioactivity. One curie equals that quantity of radioactive material in which there are 3.7×10^{10} nuclear transformations per second. The activity of 1 gram of radium is approximately 1 Ci.

10. GLOSSARY

Attocurie (aCi)—One-thousandth of a femtocurie (3.7×10^{-8} disintegrations per second).

Femtocurie (fCi)—One-billionth of a microcurie (3.7×10^{-5} disintegrations per second).

Megacurie (MCi)—One million curies (3.7×10^{16} disintegrations per sec).

Microcurie (μ Ci)—One-millionth of a curie (3.7×10^4 disintegrations per sec).

Millicurie (mCi)—One-thousandth of a curie (3.7×10^7 disintegrations per sec).

Nanocurie (nCi)—One-billionth of a curie (3.7×10^1 disintegrations per sec).

Picocurie (pCi)—One-millionth of a microcurie (3.7×10^{-2} disintegrations per second).

Daughter Products—See Progeny and Decay Product

Decay, Radioactive—Transformation of the nucleus of an unstable nuclide by spontaneous emission of charged particles and/or photons (see Disintegration).

Decay Chain or Decay Series—A sequence of radioactive decays (transformations) beginning with one nucleus. The initial nucleus, the parent, decays into a daughter or progeny nucleus that differs from the first by whatever particles were emitted during the decay. If further decays take place, the subsequent nuclei are also usually called daughters or progeny. Sometimes, to distinguish the sequence, the daughter of the first daughter is called the granddaughter, etc.

Decay Constant (λ)—The fraction of the number of atoms of a radioactive nuclide which decay in unit time (see Disintegration Constant).

Decay Product, Daughter Product, Progeny—A new nuclide formed as a result of radioactive decay. A nuclide resulting from the radioactive transformation of a radionuclide, formed either directly or as the result of successive transformations in a radioactive series. A decay product (daughter product or progeny) may be either radioactive or stable.

Delta Ray—Electron removed from an atom during the process of ionization (also called secondary electron). Delta rays cause a track of ionizations along their path.

Depleted uranium (DU)—Uranium having a percentage of ^{235}U smaller than the 0.7% found in natural uranium. It is obtained as a by-product from ^{235}U enrichment.

Developmental Toxicity—The occurrence of adverse effects on the developing organism that may result from exposure to a chemical or radiation prior to conception (either parent), during prenatal development, or postnatally to the time of sexual maturation. Adverse developmental effects may be detected at any point in the life span of the organism.

Disintegration Constant—Synonymous with decay constant. The fraction of the number of atoms of a radioactive material that decays per unit time (see Decay Constant.)

Disintegration, Nuclear—A spontaneous nuclear transformation (radioactivity) characterized by the emission of energy and/or mass from the nucleus. When large numbers of nuclei are involved, the process is characterized by a definite half-life (see Transformation, Nuclear).

Distribution Coefficient (K_d)—Describes the distribution of a chemical between the solid and aqueous phase at thermodynamic equilibrium, is given as follows:

$$K_d = \frac{[C]_s}{[C]_w} \quad , \quad \text{Units} = (\text{L solution})/(\text{kg solid}),$$

where $[C]_s$ is the concentration of the chemical associated with the solid phase in units of (mg)/(kg solid), and $[C]_w$ is the concentration of the chemical in the aqueous phase in units of (mg)/(L solution). As the magnitude of K_d decreases, the potential mobility of the chemical to groundwater systems increases and vice versa .

10. GLOSSARY

Dose—A general term denoting the quantity of a substance, radiation, or energy absorbed. For special purposes it must be appropriately qualified. If unqualified, it refers to radiation absorbed dose.

Absorbed Dose—The energy imparted to matter by ionizing radiation per unit mass of irradiated material at the place of interest. The unit of absorbed dose is the rad. One rad equals 100 ergs per gram. In SI units, the absorbed dose is the gray which is 1 J/kg (see Rad).

Cumulative Dose (Radiation)—The total dose resulting from repeated or continuous exposures to radiation.

Dose Assessment—An estimate of the radiation dose to an individual or a population group usually by means of predictive modeling techniques, sometimes supplemented by the results of measurement.

Dose Equivalent (DE)—A quantity used in radiation safety practice to account for the relative biological effectiveness of the several types of radiation. It expresses all radiations on a common scale for calculating the effective absorbed dose. It is defined as the product of the absorbed dose in rad and certain modifying factors. (The unit of dose equivalent is the rem. In SI units, the dose equivalent is the sievert, which equals 100 rem.)

Dose, Radiation—The amount of energy imparted to matter by ionizing radiation per unit mass of the matter, usually expressed as the unit rad, or in SI units, the gray. 100 rad = 1 gray (Gy) (see Absorbed Dose).

Maximum Permissible Dose Equivalent (MPD)—The greatest dose equivalent that a person or specified part thereof shall be allowed to receive in a given period of time.

Median Lethal Dose (MLD)—Dose of radiation required to kill, within a specified period (usually 30 days), 50% of the individuals in a large group of animals or organisms. Also called the LD₅₀, or LD_{50/30} if for 30 days.

Threshold Dose—The minimum absorbed dose that will produce a detectable degree of any given effect.

Tissue Dose—Absorbed dose received by tissue in the region of interest, expressed in rad (see Dose, Gray, and Rad).

Dose, Fractionation—A method of administering therapeutic radiation in which relatively small doses are given daily or at longer intervals.

Dose, Protraction—A method of administering therapeutic radiation by delivering it continuously over a relatively long period at a low dose rate.

Dose Rate—Absorbed dose delivered per unit time.

Dose-Response Relationship—The quantitative relationship between the amount of exposure to a toxicant and the incidence of the adverse effects.

Dosimetry—Quantification of radiation doses to cells, tissues, organs, individuals or populations resulting from specified exposures.

Early Effects (of radiation exposure)—Effects that appear within 60 days of an acute exposure.

Electron—A stable elementary particle having an electric charge equal to $\pm 1.60210 \times 10^{-19}$ C (Coulombs) and a rest mass equal to 9.1091×10^{-31} kg. A positron is a positively charged "electron" (see Positron).

10. GLOSSARY

Electron Volt—A unit of energy equivalent to the energy gained by an electron in passing through a potential difference of one volt. Larger multiple units of the electron volt are frequently used: keV for thousand or kilo electron volts; MeV for million or mega electron volts (eV). $1 \text{ eV} = 1.6 \times 10^{-12} \text{ erg}$.

Embryotoxicity and Fetotoxicity—Any toxic effect on the conceptus as a result of prenatal exposure to a chemical; the distinguishing feature between the two terms is the stage of development during which the insult occurred. The terms, as used here, include malformations and variations, altered growth, and *in utero* death.

Energy—Capacity for doing work. "Potential energy" is the energy inherent in a mass because of its spatial relation to other masses. "Kinetic energy" is the energy possessed by a mass because of its motion (SI unit: joules):

Binding Energy (Electron)—The amount of energy that must be expended to remove an electron from an atom.

Binding Energy (Nuclear)—The energy represented by the difference in mass between the sum of the component parts and the actual mass of the nucleus. It represents the amount of energy that must be expended to break a nucleus into its component neutrons and protons.

Excitation Energy—The energy required to change a system from its ground state to an excited state. Each different excited state has a different excitation energy.

Ionizing Energy—The energy required to knock an electron out of an atom. The average energy lost by electrons or beta particles in producing an ion pair in air or in soft tissue is about 34 eV.

Radiant Energy—The energy of electromagnetic radiation, such as radio waves, visible light, x and gamma rays.

Enriched Material—Material in which the relative amount of one or more isotopes of a constituent has been increased.

Enriched Uranium—Uranium in which the abundance of the ^{235}U isotope is increased above normal.

Enrichment, Isotopic—An isotopic separation process by which the relative abundances of the isotopes of a given element are altered, thus producing a form of the element that has been enriched in one or more isotopes and depleted in others. In uranium enrichment, the percentage of uranium-235 in natural uranium can be increased from 0.7% to >90% in a gaseous diffusion process based on the different thermal velocities of the constituents of natural uranium (^{234}U , ^{235}U , ^{238}U) in the molecular form UF_6 .

EPA Health Advisory—An estimate of acceptable drinking water levels for a chemical substance based on health effects information. A health advisory is not a legally enforceable federal standard, but serves as technical guidance to assist federal, state, and local officials.

Epidemiology—Refers to the investigation of factors that determine the frequency and distribution of disease or other health-related conditions within a defined human population during a specified period.

Equilibrium, Radioactive—In a radioactive series, the state which prevails when the ratios between the activities of two or more successive members of the series remains constant.

Secular Equilibrium—If a parent element has a very much longer half-life than the daughters (so there is not appreciable change in its amount in the time interval required for later products to attain equilibrium) then, after equilibrium is reached, equal numbers of atoms of all members of the series disintegrate in unit time. This condition is never exactly attained, but is essentially established in such a case as ^{226}Ra and its transformation series to stable ^{206}Pb . The half-life of ^{226}Ra is about 1,600 years; of ^{222}Rn , approximately 3.82 days, and of each of the subsequent members, a few minutes.

10. GLOSSARY

After about a month, essentially the equilibrium amount of radon is present; then (and for a long time) all members of the series disintegrate the same number of atoms per unit time. At this time, the activity of the daughter is equal to the activity of the parent.

Transient Equilibrium—If the half-life of the parent is short enough so the quantity present decreases appreciably during the period under consideration, but is still longer than that of successive members of the series, a stage of equilibrium will be reached after which all members of the series decrease in activity exponentially with the period of the parent. At this time, the ratio of the parent activity to the daughter activity is constant.

Equilibrium, Electron—The condition in a radiation field where the energy of the electrons entering a volume equals the energy of the electrons leaving that volume.

Equilibrium Fraction (F)—In radon-radon daughter equilibrium, the parents and daughters have equal radioactivity, that is, as many decay into a specific nuclide as decay out. However, if fresh radon is continually entering a volume of air or if daughters are lost by processes other than radioactive decay, e.g., plate out or migration out of the volume, a disequilibrium develops. The equilibrium fraction is a measure of the degree of equilibrium/disequilibrium. The equilibrium fraction is used to estimate working levels based on measurement of radon only. For radon, 1 working-level concentration is defined as 100 pCi of radon in equilibrium with its 4 successive progeny in 1 liter of air. Thus, 100 pCi/L radon at 50% equilibrium is 0.5 WL.

Excitation—The addition of energy to a system, thereby transferring it from its ground state to an excited state. Excitation of a nucleus, an atom, or a molecule can result from absorption of photons or from inelastic collisions with other particles. The excited state of an atom is an unstable or metastable state and will return to ground state by radiation of the excess energy.

Exposure (Chemical)—Contact of an organism with a chemical or physical agent. Exposure is quantified as the amount of the agent available at the exchange boundaries of the organism (e.g., skin, lungs, gut) and available for absorption.

Exposure (Radiation)—Being exposed to ionizing radiation or to a radioactive material. A measure of the ionization produced in air by x or gamma radiation; the sum of the electric charges on all ions of one sign produced in air when all electrons liberated by photons in a volume of air are completely stopped in air (dQ), divided by the mass of the air in the volume (dm). The unit of exposure in air is the roentgen, or coulomb per kilogram (SI units). One roentgen is equal to 2.58×10^{-4} coulomb per kilogram (C/kg).

Fission, Nuclear—A nuclear transformation characterized by the splitting of a nucleus into at least two other nuclei and several neutrons, and is accompanied by the release of a relatively large amount of energy.

Gamma Ray, Penetrating—Short wavelength electromagnetic radiation of nuclear origin.

Genetic Effect of Radiation—Inheritable change, chiefly mutations, produced by the absorption of ionizing radiation by germ cells. Genetic effects have not been observed in any human population exposed at any dose level.

Genotoxicity—A specific adverse effect on the genome of living cells that, upon the duplication of affected cells, can be expressed as a mutagenic, clastogenic or carcinogenic event because of specific alteration of the molecular structure of the genome.

Gray (Gy)—SI unit of absorbed dose, 1 J/kg. One gray equals 100 rad (see Units).

Half-life, Radioactive—Time required for a radioactive substance to lose 50% of its activity by decay. Each radio-nuclide has a unique physical half-life. Known also as physical half-time and symbolized as $T_{1/2}$ or T_{rad} .

10. GLOSSARY

Half-life, Effective—See Half-Time, Effective.

Half-time, Biological—Time required for an organ, tissue, or the whole body to eliminate one-half of any absorbed substance by regular processes of elimination. This is the same for both stable and radioactive isotopes of a particular element, and is sometimes referred to as half-time, symbolized as t_{biol} or T_{b} .

Half-time, Effective—Time required for a radioactive element in an organ, tissue, or the whole body to be diminished 50% as a result of the combined action of radioactive decay and biological elimination, symbolized as T_{e} or T_{eff} .

$$\text{Effective Half-time} = \frac{\text{Biological half-time} \times \text{Radioactive half-life}}{\text{Biological half-time} + \text{Radioactive half-life}}$$

Immediately Dangerous to Life or Health (IDLH)—The maximum environmental concentration of a contaminant from which one could escape within 30 minutes without any escape-impairing symptoms or irreversible health effects.

Immunologic Toxicity—The occurrence of adverse effects on the immune system that may result from exposure to environmental agents such as chemicals.

Immunological Effects—Functional changes in the immune response.

In Vitro—Isolated from the living organism and artificially maintained, as in a test tube. Literally, “in glass.”

In Vivo—Occurring within the living organism. Literally, “in life.”

Intensity—Amount of energy per unit time passing through a unit area perpendicular to the line of propagation at the point in question.

Intermediate Exposure—Exposure to a chemical for a duration of 15–364 days, as specified in the Toxicological Profiles.

Internal Conversion—Process in which a gamma ray knocks an electron out of the same atom from which the gamma ray was emitted. The ratio of the number of internal conversion electrons to the number of gamma quanta emitted in the de-excitation of the nucleus is called the “conversion ratio.”

Ion—Atomic particle, atom or chemical radical bearing a net electrical charge, either negative or positive.

Ion Pair—Two particles of opposite charge, usually referring to the electron and positive atomic or molecular residue resulting after the interaction of ionizing radiation with the orbital electrons of atoms.

Ionization—The process by which a neutral atom or molecule acquires a positive or negative charge.

Primary Ionization—(1) In collision theory: the ionization produced by the primary particles as contrasted to the “total ionization” which includes the “secondary ionization” produced by delta rays. (2) In counter tubes: the total ionization produced by incident radiation without gas amplification.

Specific Ionization—Number of ion pairs per unit length of path of ionizing radiation in a medium; e.g., per centimeter of air or per micrometer of tissue.

Total Ionization—The total electric charge of one sign on the ions produced by radiation in the process of losing its kinetic energy. For a given gas, the total ionization is closely proportional to

10. GLOSSARY

the initial ionization and is nearly independent of the nature of the ionizing radiation. It is frequently used as a measure of absorption of radiation energy.

Ionization Density—Number of ion pairs per unit volume.

Ionization Path (Track)—The trail of ion pairs produced by an ionizing particle in its passage through matter.

Ionizing Radiation—Any radiation capable of knocking electrons out of atoms and producing ions. Examples: alpha, beta, gamma and x rays, and neutrons.

Isobars—Nuclides having the same mass number but different atomic numbers.

Isomers—Nuclides having the same number of neutrons and protons but capable of existing, for a measurable time, in different quantum states with different energies and radioactive properties. Commonly the isomer of higher energy decays to one with lower energy by the process of isomeric transition.

Isotopes—Nuclides having the same number of protons in their nuclei, and hence the same atomic number, but differing in the number of neutrons, and therefore in the mass number. Identical chemical properties exist in isotopes of a particular element. The term should not be used as a synonym for nuclide because isotopes refer specifically to different nuclei of the same element.

Stable Isotope—A nonradioactive isotope of an element.

Kerma (k)—A measure of the kinetic energy transferred from gamma rays or neutrons to a unit mass of absorbing medium in the initial collision between the radiation and the absorber atoms. The SI unit is J/kg. The special name of this unit is the rad (traditional system of units) or Gray (SI).

Joule—The S.I. unit for work and energy. It is equal to the work done by raising a mass of one newton through a distance of one meter ($J = Nm$), which corresponds to about 0.7 ft-pound.

Labeled Compound—A compound containing one or more radioactive atoms intentionally added to its structure. By observations of radioactivity or isotopic composition, this compound or its fragments may be followed through physical, chemical, or biological processes.

Late Effects (of radiation exposure)—Effects which appear 60 days or more following an acute exposure.

LD_{50/30}—The dose of a chemical or radiation expected to cause 50% mortality in those exposed within 30 days. For radiation, this is about 350 rad (3.5 gray) received by humans over a short period of time.

Lethal Concentration_(LO) (LC_{LO})—The lowest concentration of a chemical in air that has been reported to have caused death in humans or animals.

Lethal Concentration₍₅₀₎ (LC₅₀)—A calculated concentration of a chemical in air to which exposure for a specific length of time is expected to cause death in 50% of a defined experimental animal population within a specified time, usually 30 days.

Lethal Dose_(LO) (LD_{LO})—The lowest dose of a chemical introduced by a route other than inhalation that is expected to have caused death in humans or animals within a specified time, usually 30 days.

Lethal Dose₍₅₀₎ (LD₅₀)—The dose of a chemical which has been calculated to cause death in 50% of a defined experimental animal population.

Lethal Time₍₅₀₎ (LT₅₀)—A calculated period of time within which a specific concentration of a chemical is expected to cause death in 50% of a defined experimental animal population.

10. GLOSSARY

Linear Energy Transfer (LET)—A measure of the energy that a charged particle transfers to a material per unit path length.

Low-LET—Energy transfer characteristic of light charged particles such as electrons produced by x and gamma rays where the distance between ionizing events is large on the scale of a cellular nucleus.

High-LET—Energy transfer characteristic of heavy charged particles such as protons and alpha particles where the distance between ionizing events is small on the scale of a cellular nucleus.

Average LET—The energy of a charged particle divided by the length of the path over which it deposits all its energy in a material.

Lowest-Observed-Adverse-Effect Level (LOAEL)—The lowest dose of chemical in a study, or group of studies, that produces statistically or biologically significant increases in frequency or severity of adverse effects between the exposed population and its appropriate control.

Lung Clearance Class (fast, F; medium, M; slow, S)—A classification scheme for inhaled material according to its rate of clearance from the pulmonary region of the lungs to the blood and the gastrointestinal tract.

Lymphoreticular Effects—Represent morphological effects involving lymphatic tissues such as the lymph nodes, spleen, and thymus.

Malformations—Permanent structural changes that may adversely affect survival, development, or function.

Mass Numbers (A)—The number of nucleons (protons and neutrons) in the nucleus of an atom.

Minimal Risk Level—An estimate of daily human exposure to a substance that is likely to be without an appreciable risk of adverse noncancerous effects over a specified duration of exposure.

Morbidity—State of being diseased; morbidity rate is the incidence or prevalence of disease in a specific population.

Mutagen—A substance that causes changes (mutations) in the genetic material in a cell. Mutations can lead to birth defects, miscarriages, or cancer.

Necropsy—The gross examination of the organs and tissues of a dead body to determine the cause of death or pathological conditions.

Neurotoxicity—The occurrence of adverse effects on the nervous system following exposure to a substance.

Neutrino (ν)—A neutral particle of infinitesimally small rest mass emitted during beta plus or beta minus decay. This particle accounts for conservation of energy in beta plus and beta minus decays. It plays no role in damage from radiation.

No-Observed-Adverse-Effect Level (NOAEL)—The dose of a substance at which there were no statistically or biologically significant increases in frequency or severity of adverse effects seen between the exposed population and its appropriate control. Effects may be produced at this dose, but they are not considered to be adverse.

Nuclear reactor—A power plant that heats water by using nuclear reactions instead of burning coal, oil, or natural gas. All of these sources of energy simply heat water and use the steam which is produced to turn turbines that make electricity or propel a ship.

10. GLOSSARY

Nucleon—Common name for a constituent particle of the nucleus. Applied to a proton or neutron.

Nuclide—A species of atom characterized by the constitution of its nucleus. The nuclear constitution is specified by the number of protons (Z), number of neutrons (N), and energy content; or, alternatively, by the atomic number (Z), mass number A' (N+Z), and atomic mass. To be regarded as a distinct nuclide, the atom must be capable of existing for a measurable time. Thus, nuclear isomers are separate nuclides, whereas promptly decaying excited nuclear states and unstable intermediates in nuclear reactions are not so considered.

Octanol-Water Partition Coefficient (K_{ow})—The equilibrium ratio of the concentrations of a chemical in n-octanol and water, in dilute solution.

Odds Ratio (OR)—A means of measuring the association between an exposure (such as toxic substances and a disease or condition) which represents the best estimate of relative risk (risk as a ratio of the incidence among subjects exposed to a particular risk factor divided by the incidence among subjects who were not exposed to the risk factor). An odds ratio of greater than 1 is considered to indicate greater risk of disease in the exposed group compared to the unexposed.

Pair Production—An absorption process for x- and gamma radiation in which the incident photon is absorbed in the vicinity of the nucleus of the absorbing atom, with subsequent production of an electron and positron pair (see annihilation). This reaction can only occur for incident photon energies exceeding 1.02 MeV.

Parent—A radionuclide which, upon disintegration, yields a new nuclide, either directly or as a later member of a radioactive series.

Permissible Exposure Limit (PEL)—A maximum allowable atmospheric level of a substance in workplace air averaged over an 8-hour shift.

Pharmacokinetics—The science of quantitatively predicting the fate (disposition) of an exogenous substance in an organism. Utilizing computational techniques, it provides the means of studying the absorption, distribution, metabolism and excretion of chemicals by the body.

Pharmacokinetic Model—A set of equations that can be used to describe the time course of a parent chemical or metabolite in an animal system. There are two types of pharmacokinetic models: data-based and physiologically-based. A data-based model divides the animal system into a series of compartments which, in general, do not represent real, identifiable anatomic regions of the body whereas the physiologically-based model compartments represent real anatomic regions of the body.

Physiologically Based Pharmacodynamic (PBPD) Model—A type of physiologically-based dose-response model which quantitatively describes the relationship between target tissue dose and toxic end points. These models advance the importance of physiologically based models in that they clearly describe the biological effect (response) produced by the system following exposure to an exogenous substance.

Physiologically Based Pharmacokinetic (PBPK) Model—A model comprising a series of compartments representing organs or tissue groups with realistic weights and blood flows. These models require a variety of physiological information: tissue volumes, blood flow rates to tissues, cardiac output, alveolar ventilation rates and, possibly membrane permeabilities. The models also utilize biochemical information such as air/blood partition coefficients, and metabolic parameters. PBPK models are also called biologically based tissue dosimetry models.

Photon—A quantum of electromagnetic energy (E) whose value is the product of its frequency (ν) in hertz and Planck's constant (h). The equation is: $E = h\nu$.

10. GLOSSARY

Photoelectric Effect—An attenuation process observed for x and gamma radiation in which an incident photon interacts with a tightly bound inner orbital electron of an atom delivering all of its energy to knock the electron out of the atom. The incident photon disappears in the process.

Positron—A positively charged electron.

Potential, Ionization—The energy expressed as electron volts (eV) necessary to separate one electron from an atom, resulting in the formation of an ion pair.

Power, Stopping—A measure of the ability of a material to absorb energy from an ionizing particle passing through it; the greater the stopping power, the greater the energy absorbing ability (see Linear Energy Transfer).

Progeny—The decay product or products resulting after a radioactive decay or a series of radioactive decays. The progeny can also be radioactive, and the chain continues until a stable nuclide is formed.

Proton—Elementary nuclear particle with a positive electric charge equal numerically to the charge of the electron and a rest mass of 1.007 mass units.

Quality—A term describing the distribution of the energy deposited by a particle along its track; radiations that produce different densities of ionization per unit intensity are said to have different "qualities."

Quality Factor (Q)—The linear-energy-transfer-dependent factor by which absorbed doses are multiplied to obtain (for radiation protection purposes) a quantity that expresses - on a common scale for all ionizing radiation - the approximate biological effectiveness of the absorbed dose.

Rad—The unit of absorbed dose equal to 100 ergs per gram, or 0.01 joule per kilogram (0.01 Gy) in any medium (see Absorbed Dose).

Radiation—The emission and propagation of energy through space or through a material medium in the form of waves (e.g., the emission and propagation of electromagnetic waves, or of sound and elastic waves). The term radiation or radiant energy, when unqualified, usually refers to electromagnetic radiation. Such radiation commonly is classified according to frequency, as microwaves, infrared, visible (light), ultraviolet, and x and gamma rays (see Photon.) and, by extension, corpuscular emission, such as alpha and beta radiation, neutrons, or rays of mixed or unknown type, as cosmic radiation.

Radiation, Annihilation—Photons produced when an electron and a positron unite and cease to exist. The annihilation of a positron-electron pair results in the production of two photons, each of 0.51 MeV energy.

Radiation, Background—See Background Radiation.

Radiation, Characteristic (Discrete)—Radiation originating from an excited atom after removal of an electron from an atom. The wavelength of the emitted radiation is specific, depending only on the element and particular energy levels involved.

Radiation, External—Radiation from a source outside the body.

Radiation, Internal—Radiation from a source within the body (as a result of deposition of radionuclides in body tissues).

Radiation, Ionizing—Any electromagnetic or particulate radiation capable of producing ions, directly or indirectly, in its passage through matter (see Radiation).

Radiation, Monoenergetic—Radiation of a given type in which all particles or photons originate with and have the same energy.

10. GLOSSARY

Radiation, Scattered—Radiation which during its passage through a substance, has been deviated in direction. It may also have been modified by a decrease in energy.

Radiation, Secondary—A particle or ray that is produced when the primary radiation interacts with a material, and which has sufficient energy to produce its own ionization, such as bremsstrahlung or electrons knocked from atomic orbitals with enough energy to then produce ionization (see Delta Rays).

Radioactive Material—Material containing radioactive atoms.

Radioactivity—Spontaneous nuclear transformations that result in the formation of new elements. These transformations are accomplished by emission of alpha or beta particles from the nucleus or by the capture of an orbital electron. Each of these reactions may or may not be accompanied by a gamma photon.

Radioactivity, Artificial—Man-made radioactivity produced by particle bombardment or nuclear fission, as opposed to naturally occurring radioactivity.

Radioactivity, Induced—Radioactivity produced in a substance after bombardment with neutrons or other particles. The resulting activity is "natural radioactivity" if formed by nuclear reactions occurring in nature and "artificial radioactivity" if the reactions are caused by man.

Radioactivity, Natural—The property of radioactivity exhibited by more than 50 naturally occurring radionuclides.

Radioisotope—An unstable or radioactive isotope of an element that decays or disintegrates spontaneously, emitting radiation. Approximately 5,000 natural and artificial radioisotopes have been identified.

Radionuclide—Any radioactive isotope of any element.

Radiosensitivity—Relative susceptibility of cells, tissues, organs, organisms, or any living substance to the injurious action of radiation. Radiosensitivity and its antonym, radioresistance, are currently used in a comparative sense, rather than in an absolute one.

Reference Dose (RfD)—An estimate (with uncertainty spanning perhaps an order of magnitude) of the daily exposure of the human population to a potential hazard that is likely to be without risk of deleterious effects during a lifetime. The RfD is operationally derived from the NOAEL (from animal and human studies) by a consistent application of uncertainty factors that reflect various types of data used to estimate RfDs and an additional modifying factor, which is based on a professional judgment of the entire database on the chemical. The RfDs are not applicable to non-threshold effects such as cancer.

Relative Biological Effectiveness (RBE)—The RBE is a factor used to compare the biological effectiveness of absorbed radiation doses (i.e., rad) due to different types of ionizing radiation. More specifically, it is the experimentally determined ratio of an absorbed dose of a radiation in question to the absorbed dose of a reference radiation (typically ⁶⁰Co gamma rays or 200 keV x rays) required to produce an identical biological effect in a particular experimental organism or tissue (see Quality Factor).

Rem—A unit of dose equivalent that is used in the regulatory, administrative, and engineering design aspects of radiation safety practice. The dose equivalent in rem is numerically equal to the absorbed dose in rad multiplied by the quality factor (1 rem is equal to 0.01 sievert).

Rep—Roentgen equivalent, physical: A former unit of ionizing radiation equivalent to the dosage of 93 ergs absorbed per gram of tissue (93 erg/gm=0.93 rad).

Reportable Quantity (RQ)—The quantity of a hazardous substance that is considered reportable under CERCLA. Reportable quantities are (1) 1 pound or greater or (2) for selected substances, an amount

10. GLOSSARY

established by regulation either under CERCLA or under Sect. 311 of the Clean Water Act. Quantities are measured over a 24-hour period.

Reproductive Toxicity—The occurrence of adverse effects on the reproductive system that may result from exposure to a chemical. The toxicity may be directed to the reproductive organs and/or the related endocrine system. The manifestation of such toxicity may be noted as alterations in sexual behavior, fertility, pregnancy outcomes, or modifications in other functions that are dependent on the integrity of this system.

Roentgen (R)—A unit of exposure (in air) to ionizing radiation. It is the amount of x or gamma rays required to produce ions carrying 1 electrostatic unit of electrical charge in 1 cubic centimeter of dry air under standard conditions. Named after William Roentgen, a German scientist who discovered x rays in 1895.

Retrospective Study—A type of cohort study based on a group of persons known to have been exposed at some time in the past. Data are collected from routinely recorded events, up to the time the study is undertaken. Retrospective studies are limited to causal factors that can be ascertained from existing records and/or examining survivors of the cohort.

Self-Absorption—Absorption of radiation (emitted by radioactive atoms) by the material in which the atoms are located; in particular, the absorption of radiation within a sample being assayed.

Short-Term Exposure Limit (STEL)—The maximum concentration to which workers can be exposed for up to 15 min continually. No more than four excursions are allowed per day, and there must be at least 60 min between exposure periods. The daily TLV-TWA may not be exceeded.

SI Units—The International System of Units as defined by the General Conference of Weights and Measures in 1960. These units are generally based on the meter/kilogram/second units, with special quantities for radiation including the becquerel, gray, and sievert.

Sickness, Acute Radiation (Syndrome)—The complex symptoms and signs characterizing the condition resulting from excessive exposure of the whole body (or large part) to ionizing radiation. The earliest of these symptoms are nausea, fatigue, vomiting, and diarrhea, and may be followed by loss of hair (epilation), hemorrhage, inflammation of the mouth and throat, and general loss of energy. In severe cases, where the radiation dose is relatively high (over several hundred rad or several gray), death may occur within two to four weeks. Those who survive six weeks after exposure of a single high dose of radiation may generally be expected to recover.

Sievert (Sv)—The SI unit of any of the quantities expressed as dose equivalent. The dose equivalent in sieverts is equal to the absorbed dose, in gray, multiplied by the quality factor (1 sievert equals 100 rem).

Specific-activity—Radioactivity per unit mass of material containing a radionuclide, expressed, for example, as Ci/gram or Bq/gram.

Specific Energy—The actual energy per unit mass deposited per unit volume in a small target, such as the cell or cell nucleus, as the result of one or more energy-depositing events. This is a stochastic quantity as opposed to the average value over a large number of instance (i.e., the absorbed dose).

Standard Mortality Ratio (SMR)—A ratio of the observed number of deaths and the expected number of deaths in a specific standard population.

Stopping Power—The average rate of energy loss of a charged particle per unit thickness of a material or per unit mass of material traversed.

10. GLOSSARY

Surface-seeking Radionuclide—A bone-seeking internal emitter that is deposited and remains on the bone surface for a long period of time, although it may eventually diffuse into the bone mineral. This contrasts with a volume seeker, which deposits more uniformly throughout the bone volume.

Target Organ Toxicity—This term covers a broad range of adverse effects on target organs or physiological systems (e.g., renal, cardiovascular) extending from those arising through a single limited exposure to those assumed over a lifetime of exposure to a chemical.

Target Theory (Hit Theory)—A theory explaining some biological effects of radiation on the basis that ionization, occurring in a discrete volume (the target) within the cell, directly causes a lesion which subsequently results in a physiological response to the damage at that location. One, two, or more "hits" (ionizing events within the target) may be necessary to elicit the response.

Teratogen—A chemical that causes birth defects.

Threshold Limit Value (TLV)—The maximum concentration of a substance to which most workers can be exposed without adverse effect. TLV is a term used exclusively by the ACGIH. Other terms used to express the same concept are the MAC (Maximum Allowable Concentration) and PEL (Permissible Exposure Limits).

Time-Weighted Average (TWA)—An allowable exposure concentration averaged over a normal 8-hour workday or 40-hour workweek.

Toxic Dose (TD₅₀)—A calculated dose of a chemical, introduced by a route other than inhalation, which is expected to cause a specific toxic effect in 50% of a defined experimental animal population.

Toxicokinetic—The study of the absorption, distribution and elimination of toxic compounds in the living organism.

Toxicosis—A diseased condition resulting from poisoning.

Transformation, Nuclear—The process by which a nuclide is transformed into a different nuclide by absorbing or emitting particulate or electromagnetic radiation.

Transition, Isomeric—The process by which a nuclide decays to an isomeric nuclide (i.e., one of the same mass number and atomic number) of lower quantum energy. Isomeric transitions (often abbreviated I.T.) proceed by gamma ray and/or internal conversion electron emission.

Tritium—The hydrogen isotope with one proton and two neutrons in the nucleus (Symbol: ³H). It is radioactive and has a physical half-life of 12.3 years.

Unattached Fraction—That fraction of the radon daughters, usually ²¹⁸Po and ²¹⁴Po, which has not yet attached to a dust particle or to water vapor. As a free atom, it has a high probability of being exhaled and not retained within the lung. It is the attached fraction which is primarily retained.

Uncertainty Factor (UF)—A factor used in operationally deriving the RfD from experimental data. UFs are intended to account for (1) the variation in sensitivity among the members of the human population, (2) the uncertainty in extrapolating animal data to the case of human, (3) the uncertainty in extrapolating from data obtained in a study that is of less than lifetime exposure, and (4) the uncertainty in using LOAEL data rather than NOAEL data. Usually each of these factors is set equal to 10.

10. GLOSSARY

Units, Radiological—

Units	Equivalents
Becquerel* (Bq)	1 disintegration per second = 2.7×10^{-11} Ci
Curie (Ci)	3.7×10^{10} disintegrations per second = 3.7×10^{10} Bq
Gray* (Gy)	1 J/kg = 100 rad
Rad (rad)	100 erg/g = 0.01 Gy
Rem (rem)	0.01 sievert
Sievert* (Sv)	100 rem

*International Units, designated (SI)

Working Level (WL)—Any combination of short-lived radon daughters in 1 liter of air that will result in the ultimate emission of 1.3×10^5 MeV of potential alpha energy.

Working Level Month (WLM)—A unit of exposure to radon daughters corresponding to the product of the radon daughter concentration in Working Level (WL) and the exposure time in nominal months (1 nominal month = 170 hours). Inhalation of air with a concentration of 1 WL of radon daughters for 170 working hours results in an exposure of 1 WLM.

X rays—Penetrating electromagnetic radiations whose wave lengths are very much shorter than those of visible light. They are usually produced by bombarding a metallic target with fast electrons in a high vacuum. X rays (called characteristic x rays) are also produced when an orbital electron falls from a high energy level to a low energy level.

Zero-Threshold Linear Hypothesis—The assumption that a dose-response curve derived from data in the high dose and high dose-rate ranges may be extrapolated through the low dose and low dose range to zero, implying that, theoretically, any amount of radiation will cause some damage.

APPENDIX A

ATSDR MINIMAL RISK LEVEL AND WORKSHEETS

The Comprehensive Environmental Response, Compensation, and Liability Act (CERCLA) [42 U.S.C. 9601 et seq.], as amended by the Superfund Amendments and Reauthorization Act (SARA) [Pub. L. 99-499], requires that the Agency for Toxic Substances and Disease Registry (ATSDR) develop jointly with the U.S. Environmental Protection Agency (EPA), in order of priority, a list of hazardous substances most commonly found at facilities on the CERCLA National Priorities List (NPL); prepare toxicological profiles for each substance included on the priority list of hazardous substances; and assure the initiation of a research program to fill identified data needs associated with the substances.

The toxicological profiles include an examination, summary, and interpretation of available toxicological information and epidemiologic evaluations of a hazardous substance. During the development of toxicological profiles, Minimal Risk Levels (MRLs) are derived when reliable and sufficient data exist to identify the target organ(s) of effect or the most sensitive health effect(s) for a specific duration for a given route of exposure. An MRL is an estimate of the daily human exposure to a hazardous substance that is likely to be without appreciable risk of adverse noncancer health effects over a specified duration of exposure. MRLs are based on noncancer health effects only and are not based on a consideration of cancer effects. These substance-specific estimates, which are intended to serve as screening levels, are used by ATSDR health assessors to identify contaminants and potential health effects that may be of concern at hazardous waste sites. It is important to note that MRLs are not intended to define clean-up or action levels.

MRLs are derived for hazardous substances using the no-observed-adverse-effect level/uncertainty factor approach. They are below levels that might cause adverse health effects in the people most sensitive to such chemical-induced effects. MRLs are derived for acute (1–14 days), intermediate (15–364 days), and chronic (365 days and longer) durations and for the oral and inhalation routes of exposure. Currently, MRLs for the dermal route of exposure are not derived because ATSDR has not yet identified a method suitable for this route of exposure. MRLs are generally based on the most sensitive chemical-induced end point considered to be of relevance to humans. Serious health effects (such as irreparable damage to the liver or kidneys, or birth defects) are not used as a basis for establishing MRLs. Exposure to a level above the MRL does not mean that adverse health effects will occur.

MRLs are intended only to serve as a screening tool to help public health professionals decide where to look more closely. They may also be viewed as a mechanism to identify those hazardous waste sites that are not expected to cause adverse health effects. Most MRLs contain a degree of uncertainty because of the lack of precise toxicological information on the people who might be most sensitive (e.g., infants,

APPENDIX A

elderly, nutritionally or immunologically compromised) to the effects of hazardous substances. ATSDR uses a conservative (i.e., protective) approach to address this uncertainty consistent with the public health principle of prevention. Although human data are preferred, MRLs often must be based on animal studies because relevant human studies are lacking. In the absence of evidence to the contrary, ATSDR assumes that humans are more sensitive to the effects of hazardous substance than animals and that certain persons may be particularly sensitive. Thus, the resulting MRL may be as much as a hundredfold below levels that have been shown to be nontoxic in laboratory animals.

Proposed MRLs undergo a rigorous review process: Health Effects/MRL Workgroup reviews within the Division of Toxicology, expert panel peer reviews, and agencywide MRL Workgroup reviews, with participation from other federal agencies and comments from the public. They are subject to change as new information becomes available concomitant with updating the toxicological profiles. Thus, MRLs in the most recent toxicological profiles supersede previously published levels. For additional information regarding MRLs, please contact the Division of Toxicology, Agency for Toxic Substances and Disease Registry, 1600 Clifton Road, Mailstop E-29, Atlanta, Georgia 30333.

APPENDIX A

MINIMAL RISK LEVEL WORKSHEET

Chemical Name: Iodine (sodium iodide, potassium iodide)
CAS Number: 7553-56-2 (7681-82-5, 7681-11-0)
Date: July 20, 2001
Profile Status: Draft 3 Pre Public
Route: Inhalation Oral
Duration: Acute Intermediate Chronic
Graph Key: 6
Species: Human

Minimal Risk Level: 0.01 mg/kg/day ppm

The administered doses of iodide (as sodium iodide) were 250, 500, or 1,500 µg I/day for 14 days (Paul et al. 1988); or 500, 1,500, or 4,500 µg I/day (Gardner et al. 1988). The pre-existing dietary iodide intakes were estimated from the reported 24-hour urinary iodide excretion rate, which was 200 µg/day (Paul et al. 1988) or 300 µg I/day (Gardner et al. 1988). The total intake of iodide was estimated as the sum of the administered iodide and the estimated dietary intake: 450, 700, or 1,700 µg/day (Paul et al. 1988); or 300, 800, 1,800, or 4,800 µg/day (Gardner et al. 1988). The estimated dosages on a per kg body weight (70 kg) were: 0.0064, 0.010, or 0.024 mg/kg/day (Paul et al. 1988); or 0.011, 0.026, or 0.069 mg/kg/day (Gardner et al. 1988).

In protecting public health ATSDR recommends using the conservative lower end of this calculated NOAEL range, 0.01 mg/kg/day, to derive an acute-duration MRL of 0.01 mg/kg/day.

Reference: Gardner DF, Centor RM, Utiger RD. 1988. Effects of low dose oral iodide supplementation on thyroid function in normal men. Clin Endocrinol 28:283-288; Paul T, Meyers B, Witorsch RJ, et al. 1988. The effect of small increases in dietary iodine on thyroid function in euthyroid subjects. Metabolism 37(2):121-124.

Experimental design: Healthy euthyroid adults (9 males, 9 females) who had no history of thyroid disease or detectable antithyroid antibodies received daily oral doses of 250, 500, or 1,500 µg I/day as sodium iodide for 14 days (Paul et al. 1988). Based on 24-hour urinary excretion of iodide prior to the iodide supplement, the background iodine intake was estimated to be approximately 200 µg/day; thus, the total iodide intake was approximately 450, 700, or 1,700 µg I/day (approximately 0.0064, 0.01, or 0.024 mg/kg/day, assuming a 70-kg body weight).

Ten healthy, euthyroid, adult males received daily oral doses of 500, 1,500, or 4,500 µg I/day (as sodium iodide) for 14 days (Gardner et al. 1988). Based on 24-hour urinary excretion of iodide prior to the iodide supplement of 250–320 µg/day, the total estimated intakes were 800, 1,800, or 4,800 µg/day or approximately 0.011, 0.026, or 0.069 mg/kg/day.

Effects noted in study and corresponding doses: In the Paul et al. (1988) study, subjects who received 1,700 µg/day (0.024 mg/kg/day) had significantly depressed (5–10%) serum concentrations of TT₄, FT₄, and TT₃ compared to pretreatment levels, and serum TSH concentrations were significantly elevated (47%) compared to pretreatment values. Hormone levels were within the normal range during treatment. In this same study, nine females received daily doses of 250 or 500 µg I/day for 14 days (total intake was approximately 450 or 700 µg/day [0.0064 or 0.010 mg/kg/day]) and there were no significant changes in serum hormone concentrations.

In the Gardner et al. (1988) study, there were no effects on serum thyroid hormone or TSH concentrations at the 800 µg/day intake (0.011 mg/kg/day); however, intakes of 1,800 or 4,800 µg I/day (0.026 or 0.064 mg/kg/day) produced small (10%), but significant, transient decreases in serum TT₄ and FT₄ concentrations and an increase (48%) in serum TSH concentration, relative to the pretreatment values.

Dose and end point used for MRL derivation: 0.01 mg/kg/day; reversible subclinical hypothyroidism.

APPENDIX A

NOAEL LOAEL

Uncertainty Factors used in MRL derivation:

- 10 for use of a LOAEL
- 10 for extrapolation from animals to humans
- 10 for human variability

Although the acute NOAEL is derived from acute studies of healthy adults, supporting studies indicate that the NOAEL would be applicable to children and elderly adults (Boyages et al. 1989; Chow et al. 1991). On this basis, an uncertainty factor is not needed to adjust the NOAEL to account for human variability in sensitivity. In the Chow et al. (1991) study, 30 healthy elderly adult females, without evidence of thyroid peroxidase antibodies (TPA), received daily doses of 500 µg I/day (as potassium iodide) for 14 or 28 days. Serum concentrations of FT₄ were significantly decreased and serum TSH concentrations were significantly elevated in the women who received the iodide supplements, relative to a placebo control group. On average, the magnitude of the changes did not produce clinically significant depression in thyroid hormone levels; however, five subjects had serum TSH concentrations that exceeded 5 mU/L. The subjects had a lower dietary iodine intake than those in the Gardner et al. (1988) study; approximately 72–100 µg/day, based on urinary iodide measurements. Therefore, the total iodide intake was approximately 600 µg/day (0.0086 mg/kg/day).

In the Boyages et al. (1989) study, thyroid status was compared in groups of children, ages 7–15 years, who resided in two areas of China where drinking water iodide concentrations were either 462 µg/L (n=120) or 54 µg/L (n=51) (Boyages et al. 1989; Li et al. 1987). Although the subjects were all euthyroid with normal values for serum thyroid hormones and TSH concentrations, TSH concentrations were significantly higher in the high iodine group. The high iodide group had a 65% prevalence of goiter and a 15% prevalence of Grade 2 goiter compared to 15% for goiter and 0% for Grade 2 goiter in the low iodine group. Urinary iodine was 1,236 µg I/g creatinine in the high iodine group and 428 µg I/g creatinine in the low iodine group. Assuming a body weight of 40 kg and lean body mass of 85% of body weight, the above urinary iodine/creatinine ratios are approximately equivalent to iodine excretion rates, or steady-state ingestion rates of 1,150 µg/day (0.029 mg/kg/day) and 400 µg/day (0.01 mg/kg/day) in the high and low iodide groups, respectively.

The MRL is higher than the National Research Council Recommended Dietary Allowance of 150 µg/day (0.0021 mg/kg/day for a 70-kg adult), with additional allowances of 25 µg/day (0.0025 mg/kg/day) and 50 µg/day (0.0029 mg/kg/day) during pregnancy and lactation, respectively (NRC 1989).

Was a conversion factor used from ppm in food or water to a mg/body weight dose? No; however, urinary iodide levels were converted to estimates of iodine intakes. Steady-state baseline dietary intakes of iodide were assumed to be equivalent to the reported 24-hour urinary iodine excretion rates. This assumption is consistent with information available on the toxicokinetics of iodide that indicates nearly complete absorption of ingested iodide and that urinary excretion accounts for >97% of the absorbed dose (see Sections 3.4.1.2 and 3.4.4.2). The assumption is also supported by studies in which 24-hour urinary iodide was measured before and after supplementation (Kahaly et al. 1998; Konno et al. 1993b). For example, 31 patients received oral supplements of 382 µg I/day for 6 months. Prior to the supplementation, the mean 24-hour urinary iodide excretion rate was 36 µg/day (range, 13–69), whereas, after 6 months of iodide supplementation, the mean 24-hour urinary iodide excretion rate was 415 µg/day (Kahaly et al. 1998). The difference between these two values, 379 µg/day, is nearly identical to the supplemental dose of 382 µg/day.

If an inhalation study in animals, list conversion factors used in determining human equivalent dose: NA

Was a conversion used from intermittent to continuous exposure? No.

Other additional studies or pertinent information that lend support to this MRL: Two other acute studies reported NOAELs and LOAELs of 0.3 and 1.0 mg/kg/day, respectively (Robison et al. 1998, 1999), which

APPENDIX A

are substantially higher than those from the Paul et al. (1988) and Gardner et al. (1988) studies. These suggest that doses much higher than the MRL can be tolerated in some people without producing thyroid gland suppression.

Agency Contact (Chemical Manager): John Risher, Ph.D.

APPENDIX A

MINIMAL RISK LEVEL WORKSHEET

Chemical Name: Iodine (sodium iodide, potassium iodide)
CAS Number: 7553-56-2 (7681-82-5, 7681-11-0)
Date: July 20, 2001
Profile Status: Draft 3 Pre Public
Route: Inhalation Oral
Duration: Acute Intermediate Chronic
Graph Key: 29
Species: Human

Minimal Risk Level: 0.01 mg/kg/day ppm

Iodine intakes estimated from urinary iodine levels (see below) were 400 and 1,150 µg/day. These correspond to 0.010 or 0.029 mg/kg/day for a 40-kg child of age 11 years.

Reference: Boyages SC, Bloot AM, Maberly GF, et al. 1989. Thyroid autoimmunity in endemic goitre caused by excessive iodine intake. Clin Endocrinol 31:452-465; Li W, Qu C, Jia G, et al. 1987. Endemic goitre in Central China caused by excessive iodine intake. Lancet, August 1:257-258.

Experimental design: Thyroid status was compared in groups of children, ages 7–15 years, who resided in two areas of China where drinking water iodide concentrations were either 462 µg/L (n=120) or 54 µg/L (N=51) (Boyages et al. 1989; Li et al. 1987). Urinary iodine was 1,236 µg I/g creatinine in the high iodine group and 428 µg I/g creatinine in the low iodine group. Assuming a body weight of 40 kg and lean body mass of 85% of body weight, the above urinary iodine/creatinine ratios are approximately equivalent to iodine excretion rates, or steady state ingestion rates of 1,150 (29 µg/kg/day) and 400 µg/day (10 µg/kg/day) in the high and low iodide groups, respectively.

Effects noted in study and corresponding doses: Although the subjects were all euthyroid with normal values for serum thyroid hormones and TSH concentrations, TSH concentrations were significantly higher (33%) in the high iodine group. The high iodide group had a 65% prevalence of goiter and a 15% prevalence of Grade 2 goiter compared to 15% for goiter and 0% for Grade 2 goiter in the low iodine group.

Dose and end point used for MRL derivation: 0.01 mg/kg/day; subclinical hypothyroidism with thyroid gland enlargement.

NOAEL LOAEL

Uncertainty Factors used in MRL derivation:

- 10 for use of a LOAEL
- 10 for extrapolation from animals to humans
- 10 for human variability

An uncertainty factor is not needed to adjust the NOAEL to account for human variability in sensitivity because the NOAEL is based on a sensitive end point in children, a sensitive subpopulation. Supporting studies indicate that the NOAEL would be applicable to elderly adults who may represent another sensitive subpopulation (Chow et al. 1991; Szabolcs et al. 1997). In the Chow et al. (1991) study, 30 healthy elderly adult females, without evidence of thyroid peroxidase antibodies (TPA), received daily doses of 500 µg I/day (as potassium iodide) for 14 or 28 days. Serum concentrations of FT₄ were significantly decreased and serum TSH concentrations were significantly elevated in the women who received the iodide supplements, relative to a placebo control group. On average, the magnitude of the changes did not produce clinically significant depression in thyroid hormone levels; however, five subjects had serum TSH concentrations that exceeded 5 mU/L. The pre-existing dietary iodine intake was approximately

APPENDIX A

72–100 µg/day, based on urinary iodide measurements. Therefore, the total iodide intake was approximately 600 µg/day (0.0086 mg/kg/day).

Szabolcs et al. (1997) studied a group of elderly nursing home residents in the Carpathian Basin and revealed a prevalence of hypothyroidism that increased with increasing iodine intake. Subjects were from one of three regions where, based on reported urinary iodine levels of 72, 100, or 513 µg I/g creatinine, the iodine intakes were approximately 117, 163, or 834 µg/day (0.0017, 0.0023, or 0.012 mg/kg/day for low, n=119; moderate, n=135; or high intake, n=92, respectively). The prevalence of elevated serum TSH concentrations together with serum FT₄ concentrations below the normal range, was 0.95, 1.5, and 7.6% in the low, moderate, and high iodine groups, respectively. If a prevalence of abnormal thyroid hormone levels of less than 5% is considered a NOAEL, this study supports a NOAEL in elderly adults that is slightly below 0.012 mg/kg/day. Linear interpolation of the dose-prevalence data reported above yields an estimate of a 5% prevalence at an iodine intake of approximately 0.008 mg/kg/day.

The MRL is higher than the National Research Council Recommended Dietary Allowance of 150 µg/day (0.0021 mg/kg/day for a 70-kg adult), with additional allowances of 25 µg/day (0.0025 mg/kg/day) and 50 µg/day (0.0029 mg/kg/day) during pregnancy and lactation, respectively (NRC 1989).

Was a conversion factor used from ppm in food or water to a mg/body weight dose? No; however, urinary iodide levels were converted to estimates of iodine intakes. Urinary iodide:creatinine ratios were converted to estimated iodide intake as follows assuming a constant relationship between urinary creatinine excretion rate and lean body mass. The rate of creatinine excretion (e.g., U_{Cr}, g creatinine/day) was calculated from the relationship between lean body mass (LBM) and U_{Cr}:

$$LBM = 0.0272 \cdot \dot{U}_{Cr} + 8.58$$

where the constants 0.0272 and 8.58 are the weighted arithmetic mean of estimates of these variables from eight studies reported in Forbes and Bruining (1976). Lean body mass was calculated as follows (ICRP 1981):

APPENDIX A

$$LBM = BW \cdot 0.85, \text{ females}$$

$$LBM = BW \cdot 0.88, \text{ males}$$

where BW is the reported body weight for children of age 11 years (40 kg) (EPA 1997). Iodide intake was calculated as:

$$\text{Intake}_I = U_{I/Cr} \cdot \dot{U}_{Cr}$$

where $U_{I/Cr}$ is the urinary iodide:creatinine ratio ($\mu\text{g I/g creatinine}$). This approach yields relationships between 24-hour urinary iodide excretion rates and the urinary iodide:creatinine ratios that are in reasonable agreement with observation (Konno et al. 1993b). The approach is consistent with information available on the toxicokinetics of iodide that indicates nearly complete absorption of ingested iodide and that urinary excretion accounts for >97% of the absorbed dose (see Sections 3.4.1.2 and 3.4.4.2).

If an inhalation study in animals, list conversion factors used in determining human equivalent dose: NA

Was a conversion used from intermittent to continuous exposure? No.

Other additional studies or pertinent information that lend support to this MRL: One other study of elderly adults supports the MRL as being protective of this population. Thyroid status was compared in 423 residents (ages 66–70 years) of Jutland, Denmark who had iodine intakes of 40–60 $\mu\text{g/day}$ (0.7 $\mu\text{g/kg/day}$) and 100 residents of Iceland who had intakes of 300–350 $\mu\text{g/day}$ (5 $\mu\text{g/kg/day}$) (Laurberg et al. 1998). Subjects from the high iodine intake region had a significantly higher prevalence (18%) of serum TSH levels above the high end of the normal range (>4 mU/L) compared to subjects from the low iodine region (3.8%). The prevalence of serum TSH concentrations above 10 mU/L was 4.0% in the high iodine region and 0.9% in the low iodine region. Females in both regions had a significantly higher prevalence of elevated TSH concentrations than males. Serum concentrations of T_4 were not depressed, even in subjects with TSH concentrations that exceeded 10 mU/L. Thus, although the subjects appeared to be euthyroid, the higher iodine intakes were associated with a subclinical suppression of the thyroid gland as indicated by a high prevalence of elevated serum TSH concentrations.

Agency Contact (Chemical Manager): John Risher, Ph.D.

APPENDIX B

USER'S GUIDE

Chapter 1

Public Health Statement

This chapter of the profile is a health effects summary written in non-technical language. Its intended audience is the general public especially people living in the vicinity of a hazardous waste site or chemical release. If the Public Health Statement were removed from the rest of the document, it would still communicate to the lay public essential information about the chemical.

The major headings in the Public Health Statement are useful to find specific topics of concern. The topics are written in a question and answer format. The answer to each question includes a sentence that will direct the reader to chapters in the profile that will provide more information on the given topic.

Chapter 2

Relevance to Public Health

This chapter provides an overview of the nature, manufacture, uses, general population exposures, and health effects of the substance under review. This overview is followed by a discussion of the most critical health effects. The discussion of health effects is based on evaluations of existing toxicologic, epidemiologic, and toxicokinetic information. This summary is designed to present interpretive, weight-of-evidence discussions for human health end points by addressing the following questions.

1. What effects are known to occur in humans?
2. What effects observed in animals are likely to be of concern to humans?
3. What exposure conditions are likely to be of concern to humans, especially around hazardous waste sites?

The chapter covers end points in the same order they appear within the Discussion of Health Effects by Route of Exposure section, by route (inhalation, oral, dermal) and within route by effect. Human data are presented first, then animal data. Both are organized by duration (acute, intermediate, chronic). *In vitro* data and data from parenteral routes (intramuscular, intravenous, subcutaneous, etc.) are also considered in this chapter. If data are located in the scientific literature, a table of genotoxicity information is included.

The carcinogenic potential of the profiled substance is qualitatively evaluated, when appropriate, using existing toxicokinetic, genotoxic, and carcinogenic data. ATSDR does not currently assess cancer potency or perform cancer risk assessments. Minimal risk levels (MRLs) for noncancer end points (if derived) and the end points from which they were derived are indicated and discussed.

Limitations to existing scientific literature that prevent a satisfactory evaluation of the relevance to public health are identified in the Chapter 3 Data Needs section.

Interpretation of Minimal Risk Levels

Where sufficient toxicologic information is available, we have derived minimal risk levels (MRLs) for inhalation and oral routes of entry at each duration of exposure (acute, intermediate, and chronic). These MRLs are not meant to support regulatory action; but to acquaint health professionals with exposure levels at which adverse health effects are not expected to occur in humans. They should help physicians and public health officials determine the safety of a community living near a chemical emission, given the

APPENDIX B

concentration of a contaminant in air or the estimated daily dose in water. MRLs are based largely on toxicological studies in animals and on reports of human occupational exposure.

MRL users should be familiar with the toxicologic information on which the number is based. Chapter 2, "Relevance to Public Health," contains basic information known about the substance. Other sections such as Chapter 3 Section 3.9, "Interactions with Other Substances," and Section 3.10, "Populations that are Unusually Susceptible" provide important supplemental information.

MRL users should also understand the MRL derivation methodology. MRLs are derived using a modified version of the risk assessment methodology the Environmental Protection Agency (EPA) provides (Barnes and Dourson 1988) to determine reference doses for lifetime exposure (RfDs).

To derive an MRL, ATSDR generally selects the most sensitive end point which, in its best judgement, represents the most sensitive human health effect for a given exposure route and duration. ATSDR cannot make this judgement or derive an MRL unless information (quantitative or qualitative) is available for all potential systemic, neurological, and developmental effects. If this information and reliable quantitative data on the chosen end point are available, ATSDR derives an MRL using the most sensitive species (when information from multiple species is available) with the highest NOAEL that does not exceed any adverse effect levels. When a NOAEL is not available, a lowest-observed-adverse-effect level (LOAEL) can be used to derive an MRL, and an uncertainty factor (UF) of 10 must be employed. Additional uncertainty factors of 10 must be used both for human variability to protect sensitive subpopulations (people who are most susceptible to the health effects caused by the substance) and for interspecies variability (extrapolation from animals to humans). In deriving an MRL, these individual uncertainty factors are multiplied together. The product is then divided into the inhalation concentration or oral dosage selected from the study. Uncertainty factors used in developing a substance-specific MRL are provided in the footnotes of the LSE Tables.

Chapter 3

Health Effects

Tables and Figures for Levels of Significant Exposure (LSE)

Tables (3-1, 3-2, and 3-3) and figures (3-1 and 3-2) are used to summarize health effects and illustrate graphically levels of exposure associated with those effects. These levels cover health effects observed at increasing dose concentrations and durations, differences in response by species, minimal risk levels (MRLs) to humans for noncancer end points, and EPA's estimated range associated with an upper-bound individual lifetime cancer risk of 1 in 10,000 to 1 in 10,000,000. Use the LSE tables and figures for a quick review of the health effects and to locate data for a specific exposure scenario. The LSE tables and figures should always be used in conjunction with the text. All entries in these tables and figures represent studies that provide reliable, quantitative estimates of No-Observed-Adverse-Effect Levels (NOAELs), Lowest-Observed-Adverse-Effect Levels (LOAELs), or Cancer Effect Levels (CELs).

The legends presented below demonstrate the application of these tables and figures. Representative examples of LSE Table 3-1 and Figure 3-1 are shown. The numbers in the left column of the legends correspond to the numbers in the example table and figure.

LEGEND

See LSE Table 3-1

- (1) Route of Exposure One of the first considerations when reviewing the toxicity of a substance using these tables and figures should be the relevant and appropriate route of exposure. When sufficient data exists, three LSE tables and two LSE figures are presented in the document. The three LSE tables present data on the three principal routes of exposure, i.e., inhalation, oral, and dermal (LSE Table 3-1, 3-2, and 3-3, respectively). LSE figures are limited to the inhalation (LSE Figure 3-1) and oral (LSE Figure 3-2) routes. Not all substances will have data on each route of exposure and

APPENDIX B

will not therefore have all five of the tables and figures. In the case of radionuclide profiles, there are separate LSE tables, by route of exposure, for toxicity of stable isotopes and radioactive isotopes; for radioactive isotopes, there may be an LSE table for a fourth route, external exposure.

- (2) Exposure Period Three exposure periods - acute (less than 15 days), intermediate (15–364 days), and chronic (365 days or more) are presented within each relevant route of exposure. In this example, an inhalation study of intermediate exposure duration is reported. For quick reference to health effects occurring from a known length of exposure, locate the applicable exposure period within the LSE table and figure.
- (3) Health Effect The major categories of health effects included in LSE tables and figures are death, systemic, immunological, neurological, developmental, reproductive, and cancer. NOAELs and LOAELs can be reported in the tables and figures for all effects but cancer. Systemic effects are further defined in the "System" column of the LSE table (see key number 18).
- (4) Key to Figure Each key number in the LSE table links study information to one or more data points using the same key number in the corresponding LSE figure. In this example, the study represented by key number 18 has been used to derive a NOAEL and a Less Serious LOAEL (also see the 2 "18r" data points in Figure 3-1).
- (5) Species The test species, whether animal or human, are identified in this column. Chapter 2, "Relevance to Public Health," covers the relevance of animal data to human toxicity and Section 3.4, "Toxicokinetics," contains any available information on comparative toxicokinetics. Although NOAELs and LOAELs are species specific, the levels are extrapolated to equivalent human doses to derive an MRL.
- (6) Exposure Frequency/Duration The duration of the study and the weekly and daily exposure regimen are provided in this column. This permits comparison of NOAELs and LOAELs from different studies. In this case (key number 18), rats were exposed to 1,1,2,2-tetrachloroethane via inhalation for 6 hours per day, 5 days per week, for 3 weeks. For a more complete review of the dosing regimen refer to the appropriate sections of the text or the original reference paper, i.e., Nitschke et al. 1981.
- (7) System This column further defines the systemic effects. These systems include: respiratory, cardiovascular, gastrointestinal, hematological, musculoskeletal, hepatic, renal, and dermal/ocular. "Other" refers to any systemic effect (e.g., a decrease in body weight) not covered in these systems. In the example of key number 18, 1 systemic effect (respiratory) was investigated.
- (8) NOAEL A No-Observed-Adverse-Effect Level (NOAEL) is the highest exposure level at which no harmful effects were seen in the organ system studied. Key number 18 reports a NOAEL of 3 ppm for the respiratory system which was used to derive an intermediate exposure, inhalation MRL of 0.005 ppm (see footnote "b").
- (9) LOAEL A Lowest-Observed-Adverse-Effect Level (LOAEL) is the lowest dose used in the study that caused a harmful health effect. LOAELs have been classified into "Less Serious" and "Serious" effects. These distinctions help readers identify the levels of exposure at which adverse health effects first appear and the gradation of effects with increasing dose. A brief description of the specific end point used to quantify the adverse effect accompanies the LOAEL. The respiratory effect reported in key number 18 (hyperplasia) is a Less serious LOAEL of 10 ppm. MRLs are not derived from Serious LOAELs.
- (10) Reference The complete reference citation is given in Chapter 9 of the profile.
- (11) CEL A Cancer Effect Level (CEL) is the lowest exposure level associated with the onset of carcinogenesis in experimental or epidemiologic studies. CELs are always considered serious

APPENDIX B

effects. The LSE tables and figures do not contain NOAELs for cancer, but the text may report doses not causing measurable cancer increases.

- (12) Footnotes Explanations of abbreviations or reference notes for data in the LSE tables are found in the footnotes. Footnote "b" indicates the NOAEL of 3 ppm in key number 18 was used to derive an MRL of 0.005 ppm.

LEGEND**See Figure 3-1**

LSE figures graphically illustrate the data presented in the corresponding LSE tables. Figures help the reader quickly compare health effects according to exposure concentrations for particular exposure periods.

- (13) Exposure Period The same exposure periods appear as in the LSE table. In this example, health effects observed within the intermediate and chronic exposure periods are illustrated.
- (14) Health Effect These are the categories of health effects for which reliable quantitative data exists. The same health effects appear in the LSE table.
- (15) Levels of Exposure concentrations or doses for each health effect in the LSE tables are graphically displayed in the LSE figures. Exposure concentration or dose is measured on the log scale "y" axis. Inhalation exposure is reported in mg/m³ or ppm and oral exposure is reported in mg/kg/day.
- (16) NOAEL In this example, 18r NOAEL is the critical end point for which an intermediate inhalation exposure MRL is based. As you can see from the LSE figure key, the open-circle symbol indicates to a NOAEL for the test species-rat. The key number 18 corresponds to the entry in the LSE table. The dashed descending arrow indicates the extrapolation from the exposure level of 3 ppm (see entry 18 in the Table) to the MRL of 0.005 ppm (see footnote "b" in the LSE table).
- (17) CEL Key number 38r is 1 of 3 studies for which Cancer Effect Levels were derived. The diamond symbol refers to a Cancer Effect Level for the test species-mouse. The number 38 corresponds to the entry in the LSE table.
- (18) Estimated Upper-Bound Human Cancer Risk Levels This is the range associated with the upper-bound for lifetime cancer risk of 1 in 10,000 to 1 in 10,000,000. These risk levels are derived from the EPA's Human Health Assessment Group's upper-bound estimates of the slope of the cancer dose response curve at low dose levels (q_1^*).
- (19) Key to LSE Figure The Key explains the abbreviations and symbols used in the figure.

SAMPLE

Table 3-1. Levels of Significant Exposure to [Chemical x] – Inhalation

Key to figure ^a	Species	Exposure frequency/ duration	System	NOAEL (ppm)	LOAEL (effect)		Reference
					Less serious (ppm)	Serious (ppm)	
INTERMEDIATE EXPOSURE							
5	6	7	8	9			10
3	9	9	9	9	9		
4	18	Rat 13 wk 5 d/wk 6 hr/d	Resp	3 ^b	10 (hyperplasia)		Nitschke et al. 1981
CHRONIC EXPOSURE							
					11		
38	Rat	18 mo 5 d/wk 7 hr/d			9	20 (CEL, multiple organs)	Wong et al. 1982
39	Rat	89–104 wk 5 d/wk 6 hr/d				10 (CEL, lung tumors, nasal tumors)	NTP 1982
40	Mouse	79–103 wk 5 d/wk 6 hr/d				10 (CEL, lung tumors, hemangiosarcomas)	NTP 1982

^a The number corresponds to entries in Figure 3-1.

^b Used to derive an intermediate inhalation Minimal Risk Level (MRL) of 5×10^{-3} ppm; dose adjusted for intermittent exposure and divided by an uncertainty factor of 100 (10 for extrapolation from animal to humans, 10 for human variability).

SAMPLE

Figure 3-1. Levels of Significant Exposure to [Chemical X] - Inhalation

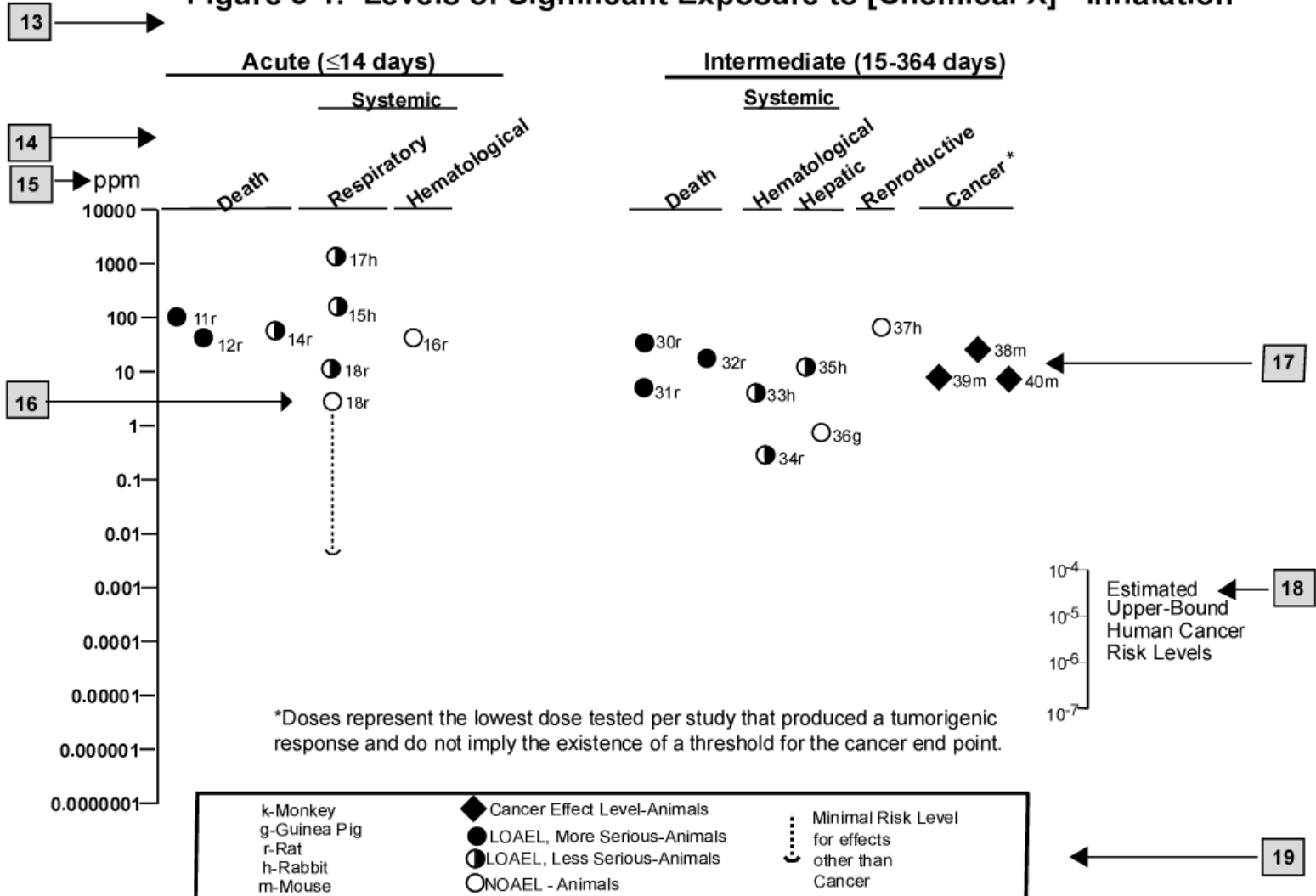

DRAFT FOR PUBLIC COMMENT

APPENDIX B

IODINE

B-6

APPENDIX C

ACRONYMS, ABBREVIATIONS, AND SYMBOLS

ACGIH	American Conference of Governmental Industrial Hygienists
ADI	Acceptable Daily Intake
ADME	Absorption, Distribution, Metabolism, and Excretion
AFID	alkali flame ionization detector
AFOSH	Air Force Office of Safety and Health
AML	acute myeloid leukemia
AOAC	Association of Official Analytical Chemists
atm	atmosphere
ATSDR	Agency for Toxic Substances and Disease Registry
AWQC	Ambient Water Quality Criteria
BAT	Best Available Technology
BCF	bioconcentration factor
BEI	Biological Exposure Index
BSC	Board of Scientific Counselors
C	Centigrade
CAA	Clean Air Act
CAG	Cancer Assessment Group of the U.S. Environmental Protection Agency
CAS	Chemical Abstract Services
CDC	Centers for Disease Control and Prevention
CEL	Cancer Effect Level
CELDS	Computer-Environmental Legislative Data System
CERCLA	Comprehensive Environmental Response, Compensation, and Liability Act
CFR	Code of Federal Regulations
Ci	curie
CL	ceiling limit value
CLP	Contract Laboratory Program
cm	centimeter
CML	chronic myeloid leukemia
CNS	central nervous system
CPSC	Consumer Products Safety Commission
CWA	Clean Water Act
d	day
Derm	dermal
DHEW	Department of Health, Education, and Welfare
DHHS	Department of Health and Human Services
DNA	deoxyribonucleic acid
DOD	Department of Defense
DOE	Department of Energy
DOL	Department of Labor
DOT	Department of Transportation
DOT/UN/ NA/IMCO	Department of Transportation/United Nations/ North America/International Maritime Dangerous Goods Code
DWEL	Drinking Water Exposure Level
ECD	electron capture detection
ECG/EKG	electrocardiogram
EEG	electroencephalogram
EEGL	Emergency Exposure Guidance Level
EPA	Environmental Protection Agency
F	Fahrenheit
F ₁	first-filial generation
FAO	Food and Agricultural Organization of the United Nations

APPENDIX C

FDA	Food and Drug Administration
FEMA	Federal Emergency Management Agency
FIFRA	Federal Insecticide, Fungicide, and Rodenticide Act
FPD	flame photometric detection
fpm	feet per minute
ft	foot
FR	<i>Federal Register</i>
g	gram
GC	gas chromatography
Gd	gestational day
gen	generation
GLC	gas liquid chromatography
GPC	gel permeation chromatography
HPLC	high-performance liquid chromatography
hr	hour
HRGC	high resolution gas chromatography
HSDB	Hazardous Substance Data Bank
IDLH	Immediately Dangerous to Life and Health
IARC	International Agency for Research on Cancer
ILO	International Labor Organization
in	inch
IRIS	Integrated Risk Information System
K _d	adsorption ratio
kg	kilogram
kkg	metric ton
K _{oc}	organic carbon partition coefficient
K _{ow}	octanol-water partition coefficient
L	liter
LC	liquid chromatography
LC _{Lo}	lethal concentration, low
LC ₅₀	lethal concentration, 50% kill
LD _{Lo}	lethal dose, low
LD ₅₀	lethal dose, 50% kill
LT ₅₀	lethal time, 50% kill
LOAEL	lowest-observed-adverse-effect level
LSE	Levels of Significant Exposure
m	meter
MA	<i>trans,trans</i> -muconic acid
MAL	Maximum Allowable Level
mCi	millicurie
MCL	Maximum Contaminant Level
MCLG	Maximum Contaminant Level Goal
mg	milligram
min	minute
mL	milliliter
mm	millimeter
mm Hg	millimeters of mercury
mmol	millimole
mo	month
mppcf	millions of particles per cubic foot
MRL	Minimal Risk Level
MS	mass spectrometry
NAAQS	National Ambient Air Quality Standard
NAS	National Academy of Science
NATICH	National Air Toxics Information Clearinghouse
NATO	North Atlantic Treaty Organization

APPENDIX C

NCE	normochromatic erythrocytes
NCI	National Cancer Institute
NIEHS	National Institute of Environmental Health Sciences
NIOSH	National Institute for Occupational Safety and Health
NIOSHTIC	NIOSH's Computerized Information Retrieval System
NFPA	National Fire Protection Association
ng	nanogram
NLM	National Library of Medicine
nm	nanometer
NHANES	National Health and Nutrition Examination Survey
nmol	nanomole
NOAEL	no-observed-adverse-effect level
NOES	National Occupational Exposure Survey
NOHS	National Occupational Hazard Survey
NPD	nitrogen phosphorus detection
NPDES	National Pollutant Discharge Elimination System
NPL	National Priorities List
NR	not reported
NRC	National Research Council
NS	not specified
NSPS	New Source Performance Standards
NTIS	National Technical Information Service
NTP	National Toxicology Program
ODW	Office of Drinking Water, EPA
OERR	Office of Emergency and Remedial Response, EPA
OHM/TADS	Oil and Hazardous Materials/Technical Assistance Data System
OPP	Office of Pesticide Programs, EPA
OPPTS	Office of Prevention, Pesticides and Toxic Substances, EPA
OPPT	Office of Pollution Prevention and Toxics, EPA
OSHA	Occupational Safety and Health Administration
OSW	Office of Solid Waste, EPA
OTS	Office of Toxic Substances
OW	Office of Water
OWRS	Office of Water Regulations and Standards, EPA
PAH	Polycyclic Aromatic Hydrocarbon
PBPD	Physiologically Based Pharmacodynamic
PBPK	Physiologically Based Pharmacokinetic
PCE	polychromatic erythrocytes
PEL	permissible exposure limit
PID	photo ionization detector
pg	picogram
pmol	picomole
PHS	Public Health Service
PMR	proportionate mortality ratio
ppb	parts per billion
ppm	parts per million
ppt	parts per trillion
PSNS	Pretreatment Standards for New Sources
REL	recommended exposure level/limit
RfC	Reference Concentration
RfD	Reference Dose
RNA	ribonucleic acid
RTECS	Registry of Toxic Effects of Chemical Substances
RQ	Reportable Quantity
SARA	Superfund Amendments and Reauthorization Act
SCE	sister chromatid exchange

APPENDIX C

sec	second
SIC	Standard Industrial Classification
SIM	selected ion monitoring
SMCL	Secondary Maximum Contaminant Level
SMR	standard mortality ratio
SNARL	Suggested No Adverse Response Level
SPEGL	Short-Term Public Emergency Guidance Level
STEL	short term exposure limit
STORET	Storage and Retrieval
TD ₅₀	toxic dose, 50% specific toxic effect
TLV	threshold limit value
TOC	Total Organic Compound
TPQ	Threshold Planning Quantity
TRI	Toxics Release Inventory
TSCA	Toxic Substances Control Act
TRI	Toxics Release Inventory
TWA	time-weighted average
U.S.	United States
UF	uncertainty factor
VOC	Volatile Organic Compound
yr	year
WHO	World Health Organization
wk	week
>	greater than
≥	greater than or equal to
=	equal to
<	less than
≤	less than or equal to
%	percent
α	alpha
β	beta
γ	gamma
δ	delta
μm	micrometer
μg	microgram
q ₁ *	cancer slope factor
-	negative
+	positive
(+)	weakly positive result
(-)	weakly negative result

APPENDIX D

OVERVIEW OF BASIC RADIATION PHYSICS, CHEMISTRY, AND BIOLOGY

Understanding the basic concepts in radiation physics, chemistry, and biology is important to the evaluation and interpretation of radiation-induced adverse health effects and to the derivation of radiation protection principles. This appendix presents a brief overview of the areas of radiation physics, chemistry, and biology and is based to a large extent on the reviews of Mettler and Moseley (1985), Hobbs and McClellan (1986), Eichholz (1982), Hendee (1973), Cember (1996), and Early et al. (1979).

D.1 RADIONUCLIDES AND RADIOACTIVITY

The substances we call elements are composed of atoms. Atoms in turn are made up of neutrons, protons and electrons: neutrons and protons in the nucleus and electrons in a cloud of orbits around the nucleus. Nuclide is the general term referring to any nucleus along with its orbital electrons. The nuclide is characterized by the composition of its nucleus and hence by the number of protons and neutrons in the nucleus. All atoms of an element have the same number of protons (this is given by the atomic number) but may have different numbers of neutrons (this is reflected by the atomic mass numbers or atomic weight of the element). Atoms with different atomic mass but the same atomic numbers are referred to as isotopes of an element.

The numerical combination of protons and neutrons in most nuclides is such that the nucleus is quantum mechanically stable and the atom is said to be stable, i.e., not radioactive; however, if there are too few or too many neutrons, the nucleus is unstable and the atom is said to be radioactive. Unstable nuclides undergo radioactive transformation, a process in which a neutron or proton converts into the other and a beta particle is emitted, or else an alpha particle is emitted. Each type of decay is typically accompanied by the emission of gamma rays. These unstable atoms are called radionuclides; their emissions are called ionizing radiation; and the whole property is called radioactivity. Transformation or decay results in the formation of new nuclides some of which may themselves be radionuclides, while others are stable nuclides. This series of transformations is called the decay chain of the radionuclide. The first radionuclide in the chain is called the parent; the subsequent products of the transformation are called progeny, daughters, or decay products.

In general there are two classifications of radioactivity and radionuclides: natural and artificial (man-made). Naturally-occurring radioactive material (NORM) exists in nature and no additional energy is necessary to place them in an unstable state. Natural radioactivity is the property of some naturally occurring, usually heavy elements, that are heavier than lead. Radionuclides, such as radium and uranium, primarily emit alpha particles. Some lighter elements such as carbon-14 and tritium (hydrogen-3) primarily emit beta particles as they transform to a more stable atom. Natural radioactive atoms heavier than lead cannot attain a stable nucleus heavier than lead. Everyone is exposed to background radiation from naturally-occurring radionuclides throughout life. This background radiation is the major source of radiation exposure to man and arises from several sources. The natural background exposures are frequently used as a standard of comparison for exposures to various artificial sources of ionizing radiation.

Artificial radioactive atoms are produced either as a by-product of fission of uranium or plutonium atoms in a nuclear reactor or by bombarding stable atoms with particles, such as neutrons or protons, directed at the stable atoms with high velocity. These artificially produced radioactive elements usually decay by emission of particles, such as positive or negative beta particles and one or more high energy photons (gamma rays). Unstable (radioactive) atoms of any element can be produced.

Both naturally occurring and artificial radioisotopes find application in medicine, industrial products, and consumer products. Some specific radioisotopes, called fall-out, are still found in the environment as a result of nuclear weapons use or testing.

D.2 RADIOACTIVE DECAY

D.2.1 Principles of Radioactive Decay

The stability of an atom is the result of the balance of the forces of the various components of the nucleus. An atom that is unstable (radionuclide) will release energy (decay) in various ways and transform to stable atoms or to other radioactive species called daughters, often with the release of ionizing radiation. If there are either too many or too few neutrons for a given number of protons, the resulting nucleus may undergo transformation. For some elements, a chain of daughter decay products may be produced until stable atoms are formed. Radionuclides can be characterized by the type and energy of the radiation emitted, the rate of decay, and the mode of decay. The mode of decay indicates how a parent compound undergoes transformation. Radiations considered here are primarily of nuclear origin, i.e., they arise from nuclear excitation, usually caused by the capture of charged or uncharged nucleons by a nucleus, or by the radioactive decay or transformation of an unstable nuclide. The type of radiation may be categorized as charged or uncharged particles, protons, and fission products) or electromagnetic radiation (gamma rays and x rays). Table D-1 summarizes the basic characteristics of the more common types of radiation encountered.

D.2.2 Half-Life and Activity

For any given radionuclide, the rate of decay is a first-order process that is constant, regardless of the radioactive atoms present and is characteristic for each radionuclide. The process of decay is a series of random events; temperature, pressure, or chemical combinations do not effect the rate of decay. While it may not be possible to predict exactly which atom is going to undergo transformation at any given time, it is possible to predict, on average, the fraction of the radioactive atoms that will transform during any interval of time.

The *activity* is a measure of the quantity of radioactive material. For these radioactive materials it is customary to describe the activity as the number of disintegrations (transformations) per unit time. The unit of activity is the curie (Ci), which was originally related to the activity of one gram of radium, but is now defined as that quantity of radioactive material in which there are:

$$1 \text{ curie (Ci)} = 3.7 \times 10^{10} \text{ disintegrations (transformations)/second (dps) or } 2.22 \times 10^{12} \text{ disintegrations (transformations)/minute (dpm).}$$

The SI unit of activity is the becquerel (Bq); 1 Bq = that quantity of radioactive material in which there is 1 transformation/second. Since activity is proportional to the number of atoms of the radioactive material, the quantity of any radioactive material is usually expressed in curies, regardless of its purity or concentration. The transformation of radioactive nuclei is a random process, and the number of transformations is directly proportional to the number of radioactive atoms present. For any pure radioactive substance, the rate of decay is usually described by its radiological half-life, T_R , i.e., the time it takes for a specified source material to decay to half its initial activity. The specific activity is an indirect measure of the rate of decay, and is defined as the activity per unit mass or per unit volume. The higher the specific activity of a radioisotope, the faster it is decaying.

The activity of a radionuclide at time t may be calculated by:

$$A = A_0 e^{-0.693t/T_{rad}}$$

where A is the activity in dps or curies or becquerels, A_0 is the activity at time zero, t is the time at which measured, and T_{rad} is the radiological half-life of the radionuclide (T_{rad} and t must be in the same units of time). The time when the activity of a sample of radioactivity becomes one-half its original value is the radioactive half-life and is expressed in any suitable unit of time.

APPENDIX D

Table D-1. Characteristics of Nuclear Radiations

Radiation	Rest mass ^a	Charge	Typical energy range	Path length ^b		Comments
				Air	Solid	
Alpha (α)	4.00 amu	+2	4–10 MeV	5–10 cm	25–80 μ m	Identical to ionized He nucleus
Negatron (β^-)	5.48x10 ⁻⁴ amu; 0.51 MeV	-1	0–4 Mev	0–10 m	0–1 cm	Identical to electron
Positron (β^+)	5.48x10 ⁻⁴ amu; 0.51 Mev	+1	0-4 Mev	0–10 m	0–1 cm	Identical to electron except for sign of charge
Neutron	1.0086 amu; 939.55 MeV	0	0–15 MeV	b	b	Free half-life: 16 min
X ray (e.m. photon)	–	0	5 keV–100 keV	b	b	Photon from transition of an electron between atomic orbits
Gamma (ρ) (e.m. photon)	–	0	10 keV–3 MeV	b	b	Photon from nuclear transformation

^a The rest mass (in amu) has an energy equivalent in MeV that is obtained using the equation $E=mc^2$, where 1 amu = 932 MeV.

^b Path lengths are not applicable to x- and gamma rays since their intensities decrease exponentially; path lengths in solid tissue are variable, depending on particle energy, electron density of material, and other factors.

amu = atomic mass unit; e.m. = electromagnetic; MeV = MegaElectron Volts

The specific activity is a measure of activity, and is fined as the activity per unit mass or per unit volume. This activity is usually expressed in curies per gram and may be calculated by

$$\text{curies/gram} = 1.3 \times 10^8 / (T_{\text{rad}}) (\text{atomic weight}) \quad \text{or}$$

$$[3.577 \times 10^5 \times \text{mass(g)}] / [T_{\text{rad}} \times \text{atomic weight}]$$

where T_{rad} is the radiological half-life in days.

In the case of radioactive materials contained in living organisms, an additional consideration is made for the reduction in observed activity due to regular processes of elimination of the respective chemical or biochemical substance from the organism. This introduces a rate constant called the biological half-life (T_{biol}) which is the time required for biological processes to eliminate one-half of the activity. This time is virtually the same for both stable and radioactive isotopes of any given element.

Under such conditions the time required for a radioactive element to be halved as a result of the combined action of radioactive decay and biological elimination is the effective clearance half-time:

$$T_{\text{eff}} = (T_{\text{biol}} \times T_{\text{rad}}) / (T_{\text{biol}} + T_{\text{rad}}).$$

Table D-2 presents representative effective half-lives of particular interest.

APPENDIX D

Table D-2. Half-Lives of Some Radionuclides in Adult Body Organs

Radionuclide	Critical organ	Half-life ^a		
		Physical	Biological	Effective
Uranium-238	Kidney	4,460,000,000 y	4 d	4 d
Hydrogen-3 ^b (Tritium)	Whole body	12.3 y	10 d	10 d
Iodine-131	Thyroid	8 d	80 d	7.3 d
Strontium-90	Bone	28 y	50 y	18 y
Plutonium-239	Bone surface	24,400 y	50 y	50 y
	Lung	24,400 y	500 d	500 d
Cobalt-60	Whole body	5.3 y	99.5 d	95 d
Iron-55	Spleen	2.7 y	600 d	388 d
Iron-59	Spleen	45.1 d	600 d	42 d
Manganese-54	Liver	303 d	25 d	23 d
Cesium-137	Whole body	30 y	70 d	70 d

^ad = days, y = years

^bMixed in body water as tritiated water

D.2.3 Interaction of Radiation with Matter

Both ionizing and nonionizing radiation will interact with materials; that is, radiation will lose kinetic energy to any solid, liquid or gas through which it passes by a variety of mechanisms. The transfer of energy to a medium by either electromagnetic or particulate radiation may be sufficient to cause formation of ions. This process is called ionization. Compared to other types of radiation that may be absorbed, such as ultraviolet radiation, ionizing radiation deposits a relatively large amount of energy into a small volume.

The method by which incident radiation interacts with the medium to cause ionization may be direct or indirect. Electromagnetic radiations (x rays and gamma photons) are indirectly ionizing; that is, they give up their energy in various interactions with cellular molecules, and the energy is then utilized to produce a fast-moving charged particle such as an electron. It is the electron that then may react with a target molecule. This particle is called a "primary ionizing particle. Charged particles, in contrast, strike the tissue or medium and directly react with target molecules, such as oxygen or water. These particulate radiations are directly ionizing radiations. Examples of directly ionizing particles include alpha and beta particles. Indirectly ionizing radiations are always more penetrating than directly ionizing particulate radiations.

Mass, charge, and velocity of a particle all affect the rate at which ionization occurs. The higher the charge of the particle and the lower the velocity, the greater the propensity to cause ionization. Heavy, highly charged particles, such as alpha particles, lose energy rapidly with distance and, therefore, do not penetrate deeply. The result of these interaction processes is a gradual slowing down of any incident particle until it is brought to rest or "stopped" at the end of its range.

D.2.4 Characteristics of Emitted Radiation

APPENDIX D

D.2.4.1 Alpha Emission. In alpha emission, an alpha particle consisting of two protons and two neutrons is emitted with a resulting decrease in the atomic mass number by four and reduction of the atomic number of two, thereby changing the parent to a different element. The alpha particle is identical to a helium nucleus consisting of two neutrons and two protons. It results from the radioactive decay of some heavy elements such as uranium, plutonium, radium, thorium, and radon. All alpha particles emitted by a given radioisotope have the same energy. Most of the alpha particles that are likely to be found have energies in the range of about 4 to 8 MeV, depending on the isotope from which they came.

The alpha particle has an electrical charge of +2. Because of this double positive charge and their size, alpha particles have great ionizing power and, thus, lose their kinetic energy quickly. This results in very little penetrating power. In fact, an alpha particle cannot penetrate a sheet of paper. The range of an alpha particle (the distance the charged particle travels from the point of origin to its resting point) is about 4 cm in air, which decreases considerably to a few micrometers in tissue. These properties cause alpha emitters to be hazardous only if there is internal contamination (i.e., if the radionuclide is inside the body).

D.2.4.2 Beta Emission. A beta particle (β) is a high-velocity electron ejected from a disintegrating nucleus. The particle may be either a negatively charged electron, termed a negatron (β^-) or a positively charged electron, termed a positron (β^+). Although the precise definition of "beta emission" refers to both β^- and β^+ , common usage of the term generally applies only to the negative particle, as distinguished from the positron emission, which refers to the β^+ particle.

D.2.4.2.1 Beta Negative Emission. Beta particle (β^-) emission is another process by which a radionuclide, with a neutron excess achieves stability. Beta particle emission decreases the number of neutrons by one and increases the number of protons by one, while the atomic mass number remains unchanged.¹ This transformation results in the formation of a different element. The energy spectrum of beta particle emission ranges from a certain maximum down to zero with the mean energy of the spectrum being about one-third of the maximum. The range in tissue is much less. Beta negative emitting radionuclides can cause injury to the skin and superficial body tissues, but mostly present an internal contamination hazard.

D.2.4.2.2 Positron Emission. In cases in which there are too many protons in the nucleus, positron emission may occur. In this case a proton may be thought of as being converted into a neutron, and a positron (β^+) is emitted.¹ This increases the number of neutrons by one, decreases the number of protons by one, and again leaves the atomic mass number unchanged. The gamma radiation resulting from the annihilation (see glossary) of the positron makes all positron emitting isotopes more of an external radiation hazard than pure β emitters of equal energy.

D.2.4.2.3 Gamma Emission. Radioactive decay by alpha, beta, or positron emission, or electron capture often leaves some of the energy resulting from these changes in the nucleus. As a result, the nucleus is raised to an excited level. None of these excited nuclei can remain in this high-energy state. Nuclei release this energy returning to ground state or to the lowest possible stable energy level. The energy released is in the form of gamma radiation (high energy photons) and has an energy equal to the change in the energy state of the nucleus. Gamma and x rays behave similarly but differ in their origin; gamma emissions originate in the nucleus while x rays originate in the orbital electron structure or from rapidly changing the velocity of an electron (e.g., as occurs when shielding high energy beta particles or stopping the electron beam in an x ray tube).

D.3 ESTIMATION OF ENERGY DEPOSITION IN HUMAN TISSUES

Two forms of potential radiation exposures can result: internal and external. The term exposure denotes physical interaction of the radiation emitted from the radioactive material with cells and tissues of the human body. An exposure can be "acute" or "chronic" depending on how long an individual or organ is exposed to the radiation. Internal exposures occur when radionuclides, which have entered the body (e.g.,

¹Neutrinos also accompany negative beta particles and positron emissions.

APPENDIX D

through the inhalation, ingestion, or dermal pathways), undergo radioactive decay resulting in the deposition of energy to internal organs. External exposures occur when radiation enters the body directly from sources located outside the body, such as radiation emitters from radionuclides on ground surfaces, dissolved in water, or dispersed in the air. In general, external exposures are from material emitting gamma radiation, which readily penetrate the skin and internal organs. Beta and alpha radiation from external sources are far less penetrating and deposit their energy primarily on the skin's outer layer. Consequently, their contribution to the absorbed dose of the total body dose, compared to that deposited by gamma rays, may be negligible.

Characterizing the radiation dose to persons as a result of exposure to radiation is a complex issue. It is difficult to: (1) measure internally the amount of energy actually transferred to an organic material and to correlate any observed effects with this energy deposition; and (2) account for and predict secondary processes, such as collision effects or biologically triggered effects, that are an indirect consequence of the primary interaction event.

D.3.1 Dose/Exposure Units

D.3.1.1 Roentgen. The roentgen (R) is a unit of x or gamma-ray exposure and is measured by the amount of ionization caused in air by gamma or x radiation. One roentgen produces 2.58×10^{-4} coulomb per kilogram of air. In the case of gamma radiation, over the commonly encountered range of photon energy, the energy deposition in tissue for a dose of 1 R is about 0.0096 joules (J) /kg of tissue.

D.3.1.2 Absorbed Dose and Absorbed Dose Rate. The absorbed dose is defined as the energy imparted by the incident radiation to a unit mass of the tissue or organ. The unit of absorbed dose is the rad; 1 rad = 100 erg/gram = 0.01 J/kg in any medium. An exposure of 1 R results in a dose to soft tissue of approximately 0.01 J/kg. The SI unit is the gray which is equivalent to 100 rad or 1 J/kg. Internal and external exposures from radiation sources are not usually instantaneous but are distributed over extended periods of time. The resulting rate of change of the absorbed dose to a small volume of mass is referred to as the absorbed dose rate in units of rad/unit time.

D.3.1.3 Working Levels and Working Level Months. Working level (WL) is a measure of the atmospheric concentration of radon and its short-lived progeny. One WL is defined as any combination of short-lived radon daughters (through polonium-214), per liter of air, that will result in the emission of 1.3×10^5 MeV of alpha energy. An activity concentration of 100 pCi radon-222/L of air, in equilibrium with its daughters, corresponds approximately to a potential alpha-energy concentration of 1 WL. The WL unit can also be used for thoron daughters. In this case, 1.3×10^5 MeV of alpha energy (1 WL) is released by the thoron daughters in equilibrium with 7.5 pCi thoron/L. The potential alpha energy exposure of miners is commonly expressed in the unit Working Level Month (WLM). One WLM corresponds to exposure to a concentration of 1 WL for the reference period of 170 hours, or more generally

$$\text{WLM} = \text{concentration (WL)} \times \text{exposure time (months)} \quad (\text{one "month"} = 170 \text{ working hours}).$$

D.3.2 Dosimetry Models

Dosimetry models are used to estimate the dose from internally deposited radioactive substances. The models for internal dosimetry consider the amount of radionuclides entering the body, the factors affecting their movement or transport through the body, distribution and retention of radionuclides in the body, and the energy deposited in organs and tissues from the radiation that is emitted during spontaneous decay processes. The dose pattern for radioactive materials in the body may be strongly influenced by the route of entry of the material. For industrial workers, inhalation of radioactive particles with pulmonary deposition and puncture wounds with subcutaneous deposition have been the most frequent. The general population has been exposed via ingestion and inhalation of low levels of naturally occurring radionuclides as well as radionuclides from nuclear weapons testing.

The models for external dosimetry consider only the photon doses to organs of individuals who are immersed in air or are exposed to a contaminated object.

APPENDIX D

D.3.2.1 Ingestion. Ingestion of radioactive materials is most likely to occur from contaminated foodstuffs or water or eventual ingestion of inhaled compounds initially deposited in the lung. Ingestion of radioactive material may result in toxic effects as a result of either absorption of the radionuclide or irradiation of the gastrointestinal tract during passage through the tract, or a combination of both. The fraction of a radioactive material absorbed from the gastrointestinal tract is variable, depending on the specific element, the physical and chemical form of the material ingested, and the diet, as well as some other metabolic and physiological factors. The absorption of some elements is influenced by age, usually with higher absorption in the very young.

D.3.2.2 Inhalation. The inhalation route of exposure has long been recognized as being a major portal of entry for both nonradioactive and radioactive materials. The deposition of particles within the lung is largely dependent upon the size of the particles being inhaled. After the particle is deposited, the retention will depend upon the physical and chemical properties of the dust and the physiological status of the lung. The retention of the particle in the lung depends on the location of deposition, in addition to the physical and chemical properties of the particles. The converse of pulmonary retention is pulmonary clearance. There are three distinct mechanisms of clearance which operate simultaneously. Ciliary clearance acts only in the upper respiratory tract. The second and third mechanisms act mainly in the deep respiratory tract. These are phagocytosis and absorption. Phagocytosis is the engulfing of foreign bodies by alveolar macrophages and their subsequent removal either up the ciliary "escalator" or by entrance into the lymphatic system. Some inhaled soluble particles are absorbed into the blood and translocated to other organs and tissues.

D.3.3 Internal Emitters

An internal emitter is a radionuclide that is inside the body. The absorbed dose from internally deposited radioisotopes depends on the energy absorbed per unit tissue by the irradiated tissue. For a radioisotope distributed uniformly throughout an infinitely large medium, the concentration of absorbed energy must be equal to the concentration of energy emitted by the isotope. An infinitely large medium may be approximated by a tissue mass whose dimensions exceed the range of the particle. All alpha and most beta radiation will be absorbed in the organ (or tissue) of reference. Gamma-emitting isotope emissions are penetrating radiation, and a substantial fraction of gamma energy may be absorbed in tissue. The dose to an organ or tissue is a function of the effective retention half-time, the energy released in the tissue, the amount of radioactivity initially introduced, and the mass of the organ or tissue.

D.4 BIOLOGICAL EFFECTS OF RADIATION

When biological material is exposed to ionizing radiation, a chain of cellular events occurs as the ionizing particle passes through the biological material. A number of theories have been proposed to describe the interaction of radiation with biologically important molecules in cells and to explain the resulting damage to biological systems from those interactions. Many factors may modify the response of a living organism to a given dose of radiation. Factors related to the exposure include the dose rate, the energy of the radiation, and the temporal pattern of the exposure. Biological considerations include factors such as species, age, sex, and the portion of the body exposed. Several excellent reviews of the biological effects of radiation have been published, and the reader is referred to these for a more in-depth discussion (Brodsky 1996; Hobbs and McClellan 1986; ICRP 1984; Mettler and Moseley 1985; Rubin and Casarett 1968).

D.4.1 Radiation Effects at the Cellular Level

According to Mettler and Moseley (1985), at acute doses up to 10 rad (100 mGy), single strand breaks in DNA may be produced. These single strand breaks may be repaired rapidly. With doses in the range of 50–500 rad (0.5–5 Gy), irreparable double-stranded DNA breaks are likely, resulting in cellular reproductive death after one or more divisions of the irradiated parent cell. At large doses of radiation, usually greater than 500 rad (5 Gy), direct cell death before division (interphase death) may occur from the direct interaction of free-radicals with essentially cellular macromolecules. Morphological changes at the cellular level, the severity of which are dose-dependent, may also be observed.

APPENDIX D

The sensitivity of various cell types varies. According to the Bergonie-Tribondeau law, the sensitivity of cell lines is directly proportional to their mitotic rate and inversely proportional to the degree of differentiation (Mettler and Moseley 1985). Rubin and Casarett (1968) devised a classification system that categorized cells according to type, function, and mitotic activity. The categories range from the most sensitive type, "vegetative intermitotic cells," found in the stem cells of the bone marrow and the gastrointestinal tract, to the least sensitive cell type, "fixed postmitotic cells," found in striated muscles or long-lived neural tissues.

Cellular changes may result in cell death, which if extensive, may produce irreversible damage to an organ or tissue or may result in the death of the individual. If the cell recovers, altered metabolism and function may still occur, which may be repaired or may result in the manifestation of clinical symptoms. These changes may also be expressed at a later time as tumors or cellular mutations, which may result in abnormal tissue.

D.4.2 Radiation Effects at the Organ Level

In most organs and tissues the injury and the underlying mechanism for that injury are complex and may involve a combination of events. The extent and severity of this tissue injury are dependent upon the radiosensitivity of the various cell types in that organ system. Rubin and Casarett (1968) describe and schematically display the events following radiation in several organ system types. These include: a rapid renewal system, such as the gastrointestinal mucosa; a slow renewal system, such as the pulmonary epithelium; and a nonrenewal system, such as neural or muscle tissue. In the rapid renewal system, organ injury results from the direct destruction of highly radiosensitive cells, such as the stem cells in the bone marrow. Injury may also result from constriction of the microcirculation and from edema and inflammation of the basement membrane, designated as the histohematic barrier (HHB), which may progress to fibrosis. In slow renewal and nonrenewal systems, the radiation may have little effect on the parenchymal cells, but ultimate parenchymal atrophy and death over several months result from HHB fibrosis and occlusion of the microcirculation.

D.4.3 Low Level Radiation Effects

Cancer is the major latent harmful effect produced by ionizing radiation and the one that most people exposed to radiation are concerned about. The ability of alpha, beta, and gamma radiation to produce cancer in virtually every tissue and organ in laboratory animals has been well-demonstrated. The development of cancer is not an immediate effect. Radiation-induced leukemia has the shortest latent period at 2 years, while other radiation induced cancers have latent periods >20 years. The mechanism by which cancer is induced in living cells is complex and is a topic of intense study. Exposure to ionizing radiation can produce cancer at any site within the body; however, some sites appear to be more common than others, such as the breast, lung, stomach, and thyroid.

DNA is a major target molecule during exposure to ionizing radiation. Other macromolecules, such as lipids and proteins, are also at risk of damage when exposed to ionizing radiation. The genotoxicity of ionizing radiation is an area of intense study, as damage to the DNA is ultimately responsible for many of the adverse toxicological effects ascribed to ionizing radiation, including cancer. Damage to genetic material is basic to developmental or teratogenic effects, as well. However, for effects other than cancer, there is little evidence of human effects at low levels of exposure.

D.5 UNITS IN RADIATION PROTECTION AND REGULATION

D.5.1 Dose Equivalent and Dose Equivalent Rate

Dose equivalent or rem is a special radiation protection quantity that is used, for administrative and radiation safety purposes only, to express the absorbed dose in a manner which considers the difference in biological effectiveness of various kinds of ionizing radiation. The ICRU has defined the dose equivalent, H, as the product of the absorbed dose, D, and the quality factor, Q, at the point of interest in biological

APPENDIX D

tissue. This relationship is expressed as $H = D \times Q$. The dose equivalent concept is applicable only to doses that are not great enough to produce biomedical effects.

The quality factor is a dimensionless quantity that depends in part on the stopping power for charged particles, and it accounts for the differences in biological effectiveness found among the types of radiation. Originally relative biological effectiveness (RBE) was used rather than Q to define the quantity, rem, which was of use in risk assessment. The generally accepted values for quality factors for various radiation types are provided in Table D-3. The dose equivalent rate is the time rate of change of the dose equivalent to organs and tissues and is expressed as rem/unit time or sievert/unit time.

Table D-3. Quality Factors (Q) and Absorbed Dose Equivalencies

Type of radiation	Quality factor (Q)	Absorbed dose equal to a unit dose equivalent*
X, gamma, or beta radiation	1	1
Alpha particles, multiple-charged particles, fission fragments and heavy particles of unknown charge	20	0.05
Neutrons of unknown energy	10	0.1
High-energy protons	10	0.1

*Absorbed dose in rad equal to 1 rem or the absorbed dose in gray equal to 1 sievert.

Source: USNRC. 1999. Standards for the protection against radiation, table 1004(b).1. 10 CFR 20.1004. U.S. Nuclear Regulatory Commission, Washington, D.C.

D.5.2 Relative Biological Effectiveness

RBE is used to denote the experimentally determined ratio of the absorbed dose from one radiation type to the absorbed dose of a reference radiation required to produce an identical biologic effect under the same conditions. Gamma rays from cobalt-60 and 200–250 keV x-rays have been used as reference standards. The term RBE has been widely used in experimental radiobiology, and the term quality factor used in calculations of dose equivalents for radiation safety purposes (ICRP 1977; NCRP 1971; UNSCEAR 1982). RBE applies only to a specific biological end point, in a specific exposure, under specific conditions to a specific species. There are no generally accepted values of RBE.

D.5.3 Effective Dose Equivalent and Effective Dose Equivalent Rate

The absorbed dose is usually defined as the mean absorbed dose within an organ or tissue. This represents a simplification of the actual problem. Normally when an individual ingests or inhales a radionuclide or is exposed to external radiation that enters the body (gamma), the dose is not uniform throughout the whole body. The simplifying assumption is that the detriment will be the same whether the body is uniformly or non-uniformly irradiated. In an attempt to compare detriment from absorbed dose of a limited portion of the body with the detriment from total body dose, the ICRP (1977) has derived a concept of effective dose equivalent. The effective dose equivalent, H_E , is

$$H_E = (\text{the sum of}) W_t H_t$$

where H_t is the dose equivalent in the tissue, W_t is the weighting factor, which represents the estimated proportion of the stochastic risk resulting from tissue, T , to the stochastic risk when the whole body is uniformly irradiated for occupational exposures under certain conditions (ICRP 1977). Weighting factors for selected tissues are listed in Table D-4.

APPENDIX D

The ICRU (1980), ICRP (1984), and NCRP (1985) now recommend that the rad, roentgen, curie, and rem be replaced by the SI units: gray (Gy), Coulomb per kilogram (C/kg), Becquerel (Bq), and sievert (Sv), respectively. The relationship between the customary units and the international system of units (SI) for radiological quantities is shown in Table D-5.

Table D-4. Weighting Factors for Calculating Effective Dose Equivalent for Selected Tissues

Tissue	Weighting factor		
	ICRP60	NCRP115/ ICRP60	NRC
Bladder	0.040	0.05	–
Bone marrow	0.143	0.12	0.12
Bone surface	0.009	0.01	0.03
Breast	0.050	0.05	0.15
Colon	0.141	0.12	–
Liver	0.022	0.05	–
Lung	0.111	0.12	0.12
Esophagus	0.034	0.05	–
Ovary	0.020	0.05	–
Skin	0.006	0.01	–
Stomach	0.139	0.12	–
Thyroid	0.021	0.05	0.03
Gonads	0.183	0.20	0.25
subtotal	0.969	1	0.70
<i>Remainder</i>	0.031	0.05	0.30

ICRP60 = International Commission on Radiological Protection, 1990 Recommendations of the ICRP;
 NCRP115 = National Council on Radiation Protection and Measurements. 1993. Risk Estimates for Radiation Protection, Report 115. Bethesda, Maryland; NRC = Nuclear Regulatory Commission.
 NRC = Nuclear Regulatory Commission, Title 10, Code of Federal Regulations, Part 20

APPENDIX D

Table D-5. Comparison of Common and SI Units for Radiation Quantities

Quantity	Customary units	Definition	SI units	Definition
Activity (A)	curie (Ci)	3.7×10^{10} transformations s^{-1}	becquerel (Bq)	s^{-1}
Absorbed dose (D)	rad (rad)	10^{-2} Jkg $^{-1}$	gray (Gy) Jkg $^{-1}$	
Absorbed dose rate (Ḑ)	rad per second (rad s $^{-1}$)	10^{-2} Jkg $^{-1}$ s $^{-1}$	gray per second (Gy s $^{-1}$)	Jkg $^{-1}$ s $^{-1}$
Dose equivalent (H)	rem (rem)	10^{-2} Jkg $^{-1}$	sievert (Sv)	Jkg $^{-1}$
Dose equivalent rate (Ḥ)	rem per second (rem s $^{-1}$)	10^{-2} Jkg $^{-1}$ s $^{-1}$	sievert per second (Sv s $^{-1}$)	Jkg $^{-1}$ s $^{-1}$
Linear energy transfer (LET)	kiloelectron volts per micrometer (keV μm^{-1})	1.602×10^{-10} Jm $^{-1}$	kiloelectron volts per micrometer (keV μm^{-1})	1.602×10^{-10} Jm $^{-1}$

Jkg $^{-1}$ = Joules per kilogram; Jkg $^{-1}$ s $^{-1}$ = Joules per kilogram per second; Jm $^{-1}$ = Joules per meter; s $^{-1}$ = per second

APPENDIX D

REFERENCES FOR APPENDIX D

ATSDR. 1990a. Toxicological profile for thorium. U.S. Department of Health and Human Services. Public Health Service. Agency for Toxic Substances and Disease Registry. Atlanta, GA.

ATSDR. 1990b. Toxicological profile for radium. U.S. Department of Health and Human Services. Public Health Service. Agency for Toxic Substances and Disease Registry. Atlanta, GA.

ATSDR. 1990c. Toxicological profile for radon. U.S. Department of Health and Human Services. Public Health Service. Agency for Toxic Substances and Disease Registry. Atlanta, GA.

ATSDR. 1999. Toxicological profile for uranium. U.S. Department of Health and Human Services. Public Health Service. Agency for Toxic Substances and Disease Registry. Atlanta, GA.

BEIR III. 1980. The effects on populations of exposure to low levels of ionizing radiation. Committee on the Biological Effects of Ionizing Radiations, National Research Council. Washington, DC: National Academy Press.

BEIR IV. 1988. Health risks of radon and other internally deposited alpha emitters. Committee on the Biological Effects of Ionizing Radiations, National Research Council. Washington, DC: National Academy Press.

BEIR V. 1988. Health effects of exposure to low levels of ionizing radiation. Committee on the Biological Effects of Ionizing Radiations, National Research Council. Washington, DC: National Academy Press.

Brodsky A. 1996. Review of radiation risks and uranium toxicity with application to decisions associated with decommissioning clean-up criteria. Hebron, Connecticut: RSA Publications.

Cember H. 1996. Introduction to health physics. New York, NY: McGraw Hill.

Early P, Razzak M, Sodee D. 1979. Nuclear medicine technology. 2nd ed. St. Louis: C.V. Mosby Company.

Eichholz G. 1982. Environmental aspects of nuclear power. Ann Arbor, MI: Ann Arbor Science.

Hendee W. 1973. Radioactive isotopes in biological research. New York, NY: John Wiley and Sons.

Hobbs C, McClellan R. 1986. Radiation and radioactive materials. In: Doull J, et al., eds. Casarett and Doull's Toxicology. 3rd ed. New York, NY: Macmillan Publishing Co., Inc., 497-530.

ICRP. 1977. International Commission on Radiological Protection. Recommendations of the International Commission on Radiological Protection. ICRP Publication 26. Vol 1. No. 3. Oxford: Pergamon Press.

ICRP. 1979. International Commission on Radiological Protection. Limits for intakes of radionuclides by workers. ICRP Publication 20. Vol. 3. No. 1-4. Oxford: Pergamon Press.

ICRP. 1979. Limits for Intakes of Radionuclides by Workers. Publication 30. International Commission on Radiological Protection. Pergamon Press.

ICRP. 1984. International Commission on Radiological Protection. A compilation of the major concepts and quantities in use by ICRP. ICRP Publication 42. Oxford: Pergamon Press.

ICRP. 1990. International Commission on Radiological Protection 1990 Recommendations of the ICRP

APPENDIX D

- ICRU. 1980. International Commission on Radiation Units and Measurements. ICRU Report No. 33. Washington, DC.
- James A. 1987. A reconsideration of cells at risk and other key factors in radon daughter dosimetry. In: Hopke P, ed. Radon and its decay products: Occurrence, properties and health effects. ACS Symposium Series 331. Washington, DC: American Chemical Society, 400-418.
- James A, Roy M. 1987. Dosimetric lung models. In: Gerber G, et al., ed. Age-related factors in radionuclide metabolism and dosimetry. Boston: Martinus Nijhoff Publishers, 95-108.
- Kondo S. 1993. Health effects of low-level radiation. Kinki University Press, Osaka, Japan (available from Medical Physics Publishing, Madison, Wisconsin).
- Kato H, Schull W. 1982. Studies of the mortality of A-bomb survivors. Report 7 Part 8, Cancer mortality among atomic bomb survivors, 1950-78. Radiat Res 90;395-432.
- Mettler F, Moseley R. 1985. Medical effects of ionizing radiation. New York: Grune and Stratton.
- NCRP. 1971. Basic radiation protection criteria. National Council on Radiation Protection and Measurements. Report No. 39. Washington, DC.
- NCRP. 1985. A handbook of radioactivity measurements procedures. 2nd ed. National Council on Radiation Protection and Measurements. Report No. 58. Bethesda, MD:
- NCRP. 1993. Risk estimates for radiation protection. National Council on Radiation Protection and Measurements. Report 115. Bethesda, Maryland
- Otake M, Schull W. 1984. Mental retardation in children exposed in utero to the atomic bombs: A reassessment. Technical Report RERF TR 1-83, Radiation Effects Research Foundation, Japan.
- Rubin P, Casarett G. 1968. Clinical radiation pathology. Philadelphia: W.B. Sanders Company, 33.
- UNSCEAR. 1977. United Nations Scientific Committee on the Effects of Atomic Radiation. Sources and effects of ionizing radiation. New York: United Nations.
- UNSCEAR. 1982. United Nations Scientific Committee on the Effects of Atomic Radiation. Ionizing radiation: Sources and biological effects. New York: United Nations.
- UNSCEAR. 1986. United Nations Scientific Committee on the Effects of Atomic Radiation. Genetic and somatic effects of ionizing radiation. New York: United Nations.
- UNSCEAR. 1988. United Nations Scientific Committee on the Effects of Atomic Radiation. Sources, effects and risks of ionization radiation. New York: United Nations.
- UNSCEAR. 1993. United Nations Scientific Committee on the Effects of Atomic Radiation. Sources and effects of ionizing radiation. New York: United Nations.
- USNRC. 1999. Standards for the protection against radiation, table 1004(b).1. 10 CFR 20.1004. U.S. Nuclear Regulatory Commission, Washington, D.C.

APPENDIX E
INDEX