

# **Emissions from a diesel engine using Fe-based fuel additives and a sintered metal filtration system**

Aleksandar D. Bugarski\*, Lead Research Engineer, *National Institute for Occupational Safety and Health, Office of Mine Safety and Health Research, 626 Cochrans Mill Rd., Pittsburgh, Pennsylvania 15236, U.S.A.*  
*abugarski@cdc.gov.*

Jon A. Hummer, Engineering Technician, *National Institute for Occupational Safety and Health, Office of Mine Safety and Health Research, 626 Cochrans Mill Rd., Pittsburgh, Pennsylvania 15236, U.S.A., jhummer@cdc.gov*

Jozef S. Stachulak, Manager Strategic Diesel Research, *MIRARCO Mining Innovation, 935 Ramsey Lake Road, Sudbury, Ontario P3E 2C6, Canada, jstachulak@mirarco.org*

Arthur Miller, Research Engineer, *National Institute for Occupational Safety and Health, Office of Mine Safety and Health Research, Spokane, Washington 99207, U.S.A., amiller@cdc.gov*

Larry D. Patts, Physical Scientist, *National Institute for Occupational Safety and Health, Office of Mine Safety and Health Research, 626 Cochrans Mill Rd., Pittsburgh, Pennsylvania 15236, U.S.A., lpatts@cdc.gov*

Emanuele G. Cauda, Senior Research Fellow, *National Institute for Occupational Safety and Health, Office of Mine Safety and Health Research, 626 Cochrans Mill Rd., Pittsburgh, Pennsylvania 15236, U.S.A., ecauda@cdc.gov*

## SUPPLEMENTAL INFORMATION

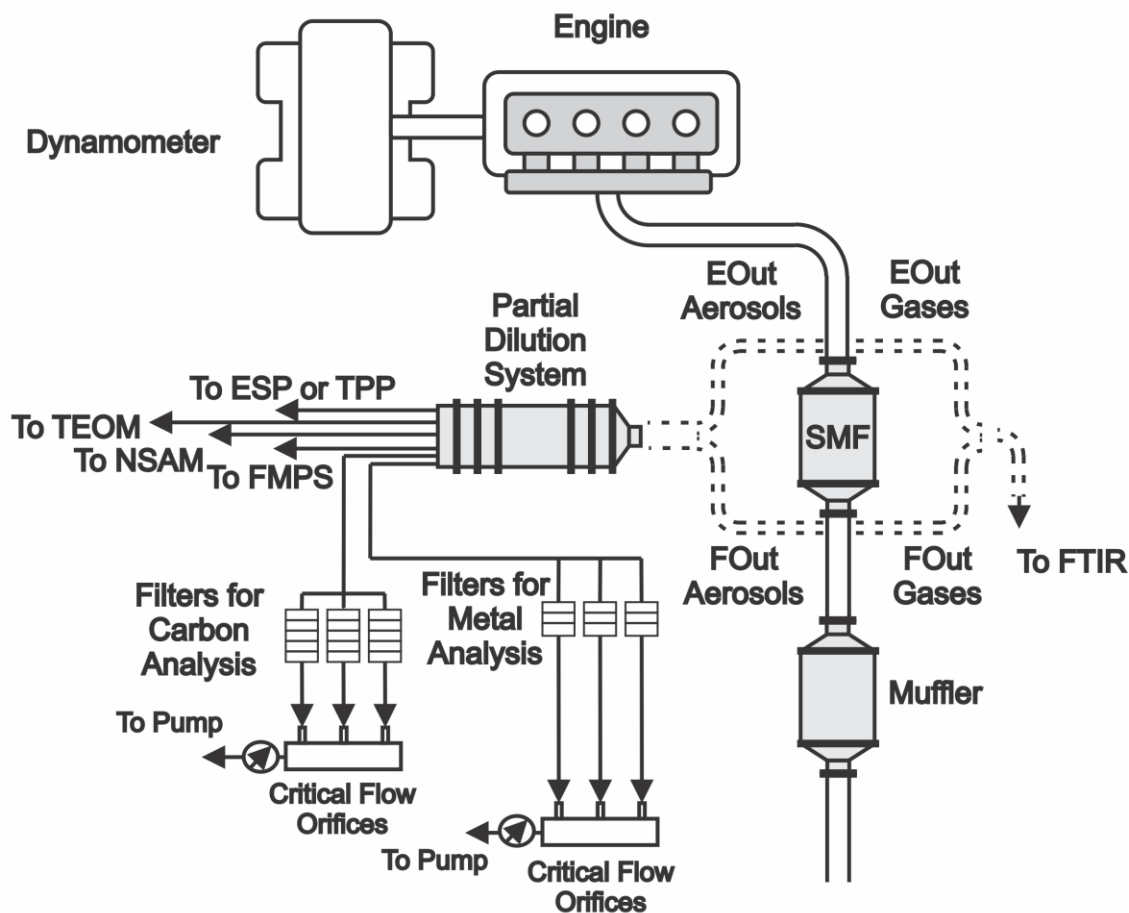

Figure S1. Laboratory layout (not to scale).

Table S1. Engine specifications

Isuzu C240		Unit
Type	in-line 4	-
Cycles	4	-
Cooling	water	-
Valves	overhead	-
Injection	indirect	-
Air intake system	naturally aspirated	-
Engine management	mechanical	
Displacement	2369 (145)	cm <sup>3</sup> (in <sup>3</sup> )
Intermittent rating	41.8 (56) @ 3000 rpm	kW (bhp)
Continuous rating	36.5 (49) @ 3000 rpm	kW (bhp)
Peak torque	146.4 (108) @ 2000 rpm	Nm (lb ft)
Moment of inertia	1499 (35.59)	kg m <sup>3</sup> (lb ft <sup>2</sup> )
Engine speed at idle	700±50	rpm
Maximum engine speed at no load	3260±50	rpm

**Table S2. Dynamometer specifications**

SAJ SE150		Unit
Type	eddy current, bidirectional, dry gap	-
Load measurement	strain gauge load cell	-
Speed measurement	Shaft-mounted sixty-tooth wheel and magnetic pulse pick	-
Maximum power	150 (201)	kW (bhp)
Maximum torque	500.4 (369)	Nm (lb ft)
Maximum speed	8000	rpm
Maximum water flow	5.9046 (1560)	m <sup>3</sup> /hour(US gallons/hour)

**Table S3. Steady-state engine operating conditions**

Mode	Description	Engine Speed	Torque	Power
		rpm	Nm	kW
R50	Rated speed 50 percent load	2950	55.6	17.2
R100	Rated speed 100 percent load	2950	111.2	34.3
I50	Intermediate speed 50 percent load	2100	69.1	14.9
I100	Intermediate speed 100 percent load	2100	136.9	30.6

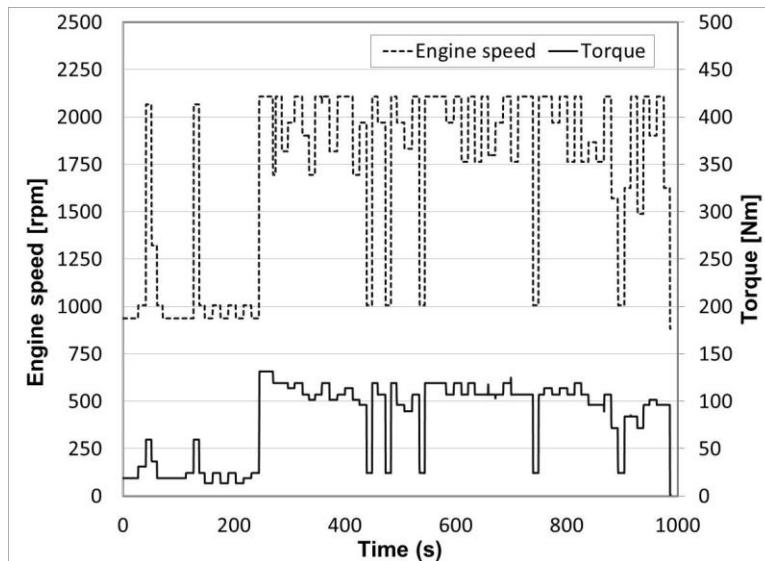

**Figure S2. Transient cycle (TR)**

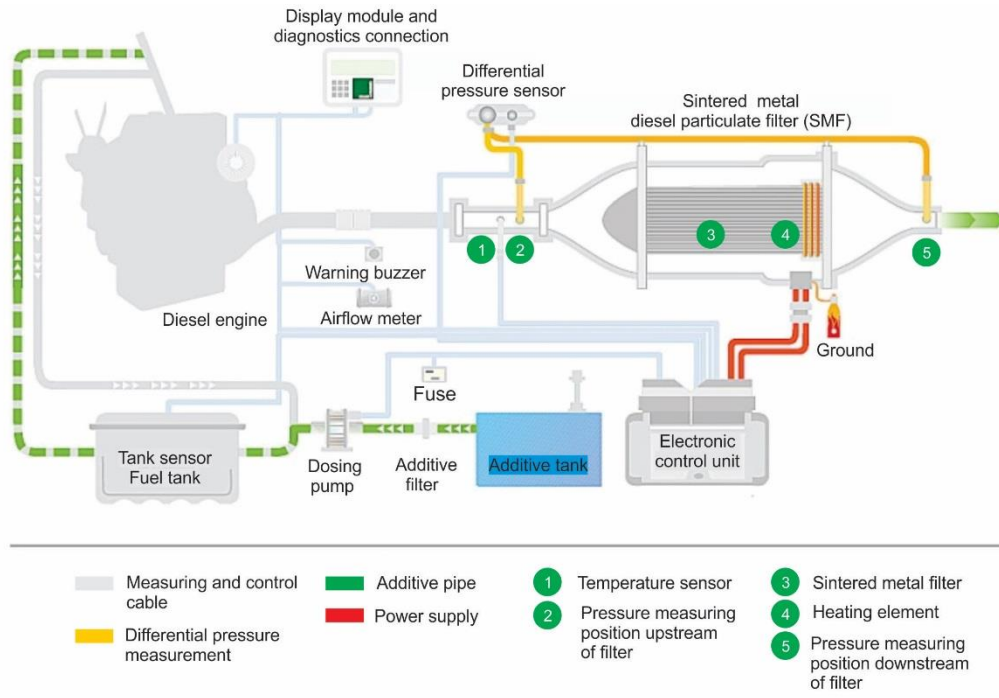

Figure S3. Mann+Hummel SMF AR system layout

Table S4. ULSD fuel properties (analyzed by Cashman Equipment Co., Sparks, NV)

Fuel Property	Test Method	Value
Heat of Combustion [BTU/gal]	ASTM D240	14368.2
API Gravity @ 15.6 °C [°API]	ASTM D1298	35.5
Cetane Number	ASTM D613	42.3
Sulfur by UV [ppm]	ASTM D5453	5.46
Flash Point, Closed Cup [°C]	ASTM D93	59.5

Table S5. FMPS data: statistical parameters including count median diameter (CMD), standard deviation of mean ( $\sigma$ ), and total number concentrations (TNC) for number size distributions measured in the EOut and FOut diluted exhaust (DR=30) with FMPS for ULSD, ULSD+DT8i, and ULSD+DT9 tests

Fuel	Measurement Location	Mode	Nucleation Mode			Accumulation Mode			TNC	
			CMD	$\Sigma$	TNC	CMD	$\sigma$	TNC	Fit	Measured
			nm	-	$\#/cm^3$	nm	-	$\#/cm^3$	$\#/cm^3$	$\#/cm^3$
ULSD	EOut	R50				54.7	1.503	9.05E+05	9.05E+05	9.60E+05
		R100				57.1	1.535	3.92E+05	3.92E+05	3.95E+05
		I50				60.7	1.546	8.10E+05	8.10E+05	8.22E+05
		I100				66.9	1.516	8.37E+05	8.37E+05	8.65E+05
	FOut	R50				81.8	1.441	1.74E+03	1.74E+03	1.74E+03
		R100	14.2	1.311	4.18E+02	82.5	1.437	1.12E+03	1.54E+03	1.44E+03
		I50				81.7	1.398	1.45E+03	1.45E+03	1.44E+03
		I100	36.3	1.793	3.69E+02	87.8	1.305	1.21E+03	1.58E+03	1.43E+03
ULSD + DT8i	EOut	R50				51.7	1.520	8.17E+05	8.17E+05	8.65E+05
		R100				52.0	1.611	4.52E+05	4.52E+05	4.78E+05
		I50				55.3	1.609	6.89E+05	6.89E+05	7.30E+05
		I100				66.2	1.552	8.88E+05	8.88E+05	9.02E+05
	FOut	R50	5.8	1.171	5.63E+02	89.5	1.451	2.18E+03	2.75E+03	2.46E+03
		R100	13.4	2.225	1.16E+03	84.6	1.466	2.48E+03	3.64E+03	3.62E+03
		I50	15.7	1.359	3.39E+02	86.0	1.401	2.58E+03	2.91E+03	2.89E+03
		I100				90.9	1.398	3.16E+03	3.16E+03	3.23E+03
ULSD + DT9	EOut	R50				56.7	1.504	9.02E+05	9.02E+05	9.23E+05
		R100				59.2	1.549	6.25E+05	6.25E+05	6.36E+05
		I50	12.8	1.338	6.79E+04	58.1	1.565	6.31E+05	6.99E+05	7.01E+05
		I100				65.3	1.527	7.58E+05	7.58E+05	7.78E+05
	FOut	R50				92.2	1.374	2.34E+03	2.34E+03	2.34E+03
		R100				93.2	1.374	2.67E+03	2.67E+03	3.11E+03
		I50				86.5	1.430	3.68E+03	3.68E+03	3.79E+03
		I100	14.3	1.825	9.93E+02	84.7	1.440	3.37E+03	4.36E+03	4.36E+03