

Information Circular 9110

Development of an Automated Breathing and Metabolic Simulator

By Nicholas Kyriazi



UNITED STATES DEPARTMENT OF THE INTERIOR
Donald Paul Hodel, Secretary

BUREAU OF MINES
Robert C. Horton, Director

Library of Congress Cataloging in Publication Data :

Kyriazi, Nicholas

Development of an automated breathing and metabolic simulator.

(Information circular ; 9110)

Bibliography.

Supt. of Docs. no.: I 28.27: 9110.

1. Respiration--Simulation methods. 2. Metabolism--Simulation methods. 3. Respirators--Testing. I. Title. II. Series: Information circular (United States. Bureau of Mines) ; 9110.

TN295.U4

[QP177]

622 s [681'.761]

86-600287

CONTENTS

	<u>Page</u>
Abstract.....	1
Introduction.....	2
Past developments.....	3
IBM ABMS.....	3
Reimers MBMS.....	5
Bellows flexibility.....	8
N ₂ fidelity.....	8
System response time.....	8
The hypoxia scenario.....	8
Reimers ABMS.....	9
DEEC Inc. ABMS.....	11
Conclusions.....	15
Appendix.--Average inhaled gas values.....	16

ILLUSTRATIONS

1. IBM ABMS photo.....	3
2. IBM breathing and metabolic systems schematic.....	4
3. IBM breathing-simulation system schematic.....	4
4. IBM temperature and humidity system schematic.....	5
5. IBM electric furnace.....	5
6. Reimers MBMS photo.....	6
7. Reimers MBMS schematic.....	7
8. Reimers ABMS photo.....	9
9. Reimers ABMS breathing-simulation system schematic.....	10
10. Reimers ABMS temperature and humidity system schematic.....	11
11. Reimers ABMS metabolic-simulation system schematic.....	12
12. DEEC Inc. ABMS photo.....	13
13. DEEC Inc. ABMS schematic.....	14
14. Comparison of CO ₂ breath waveforms.....	15
A-1. CO ₂ and O ₂ breath waveforms.....	16
A-2. Single inhalation air column.....	16
A-3. Minimum CO ₂ value vs average inhaled CO ₂ value.....	17

UNIT OF MEASURE ABBREVIATIONS USED IN THIS REPORT

h	hour	min	minute
L	liter	ms	millisecond
L/min	liter per minute	yr	year
lb	pound		

DEVELOPMENT OF AN AUTOMATED BREATHING AND METABOLIC SIMULATOR

By Nicholas Kyriazi¹

ABSTRACT

The Bureau of Mines has been developing breathing and metabolic simulator technology since 1970. Breathing simulation has been widely achieved throughout the world and used in the testing of open-circuit breathing apparatus, but satisfactory metabolism simulation has not been achieved. This situation required that the testing of closed-circuit breathing apparatus, which are the only type used in mines, be done using human test subjects. The goal was a machine that could accurately simulate both the breathing and the metabolic functions of a human being for testing of closed-circuit breathing apparatus. The advantages of using such a machine instead of a human being for testing respiratory protective devices lie in its ability to quantify metabolic input, its repeatability, and the lack of a need to deal with the vagaries of human subjects. This report will describe the breathing and metabolic simulators that have been developed and used by the Bureau over the past 15 yr.

¹Biomedical engineer, Pittsburgh Research Center, Bureau of Mines, Pittsburgh, PA.

INTRODUCTION

Closed-circuit rescue breathing apparatus have been used for over 75 yr in mine rescue and recovery missions after fires or explosions have made the mine atmosphere irrespirable. Since 1981, closed-circuit escape breathing apparatus have been legislatively mandated for every person going into an underground coal mine in the United States. At present, testing of newly developed and existing apparatus both by manufacturers and by the certifying agency, the National Institute for Occupational Safety and Health (NIOSH), is largely dependent upon human subject testing. Since metabolic demand varies with weight and condition of the human subject, and since even the same subject performing the same physical activity can have different metabolic demand levels depending upon posture and type of food recently eaten, it seems logical to question the fairness of quantitative evaluations of breathing apparatus based upon human-subject testing. This is the reasoning behind the research and development efforts by the Bureau of Mines in its quest for a simple, reliable, and repeatable breathing and metabolic simulator for the quantitative testing of breathing apparatus.

The first concept utilized for metabolism simulation was that of burning propane; this process simulated not only O_2 consumption but also CO_2 production. While achieving a measure of success, this concept proved to be very complicated and maintenance intensive. Also, there is always a degree of danger present when burning a combustible gas.

The second concept was that of cyclical removal and replacement of inhaled gases. On a breath-by-breath basis, gas is removed from the system to simulate O_2 consumption. Since simple removal of inhaled gas is not selective of O_2 , some N_2 is also removed that must be replaced on the reverse cycle. CO_2 is also added during the reverse cycle. A manual

simulator of this type was used for 2 yr at the Bureau's Pittsburgh Research Center. The major problem with this concept lay in its extreme mechanical complexity. The automated version of this simulator also suffered from the same problem. In addition, the large internal volume of this second-generation simulator had the effect of slowing the system response to rapid changes in inhaled gas concentration.

The presently used (third-generation) simulator utilizes the removal-replacement concept to simulate metabolism but does so on a continual basis rather than a cyclical one. In addition, all of the breathing and metabolic functions are controlled by a computer. The mechanical portion of the machine is simple; the complexity of the system lies in its computer software, which is not subject to maintenance problems. This concept was developed through a contract to the Noll Laboratory for Human Performance Research at the Pennsylvania State University and built by DEEC Inc., a company formed by employees of the university who were involved with the contract.

The third-generation automated breathing and metabolic simulator (ABMS) has the capability to vary over a wide range the following metabolic parameters: ventilation rate, O_2 consumption rate, CO_2 production rate, respiratory frequency, tidal volume, breathing waveform, and breathing gas temperature. Also, any number of work rates may be combined in any order to simulate various activities. The simulator monitors numerous parameters including average inhaled levels of O_2 and CO_2 , breathing resistance, and inhaled gas temperatures. The test results are stored on either a floppy or a hard disk and may be plotted in any manner desired.

The use of the Bureau-developed ABMS enables quantitative testing of closed-circuit breathing apparatus that are used

in the mining industry for both escape and rescue. As mentioned, such apparatus are tested and certified by NIOSH using human subjects of various weights. This makes apparatus design difficult as manufacturers do not know the weight of the subject their apparatus will be tested on. Present in human-subject testing are many unknown variables such as flow rate, exact CO₂ production, and exact O₂ consumption, all of which vary with the weight of the test subject. Therefore, it is necessary to overdesign the

apparatus to accommodate even the worst-case (heaviest test subject) situation. The Bureau will soon formally propose to NIOSH that a simulator such as the third-generation ABMS be used in certification testing of breathing apparatus in order to correct the perceived deficiencies in the present methods.

In the following sections, more detailed descriptions are provided of the succession of Bureau-developed breathing and metabolic simulators.

PAST DEVELOPMENTS

IBM ABMS

This simulator was developed by the Bureau through a research and development

contract with IBM completed in 1973. It was extensively modified by the Bureau over the following years. (See figure 1.) While it served its purpose during

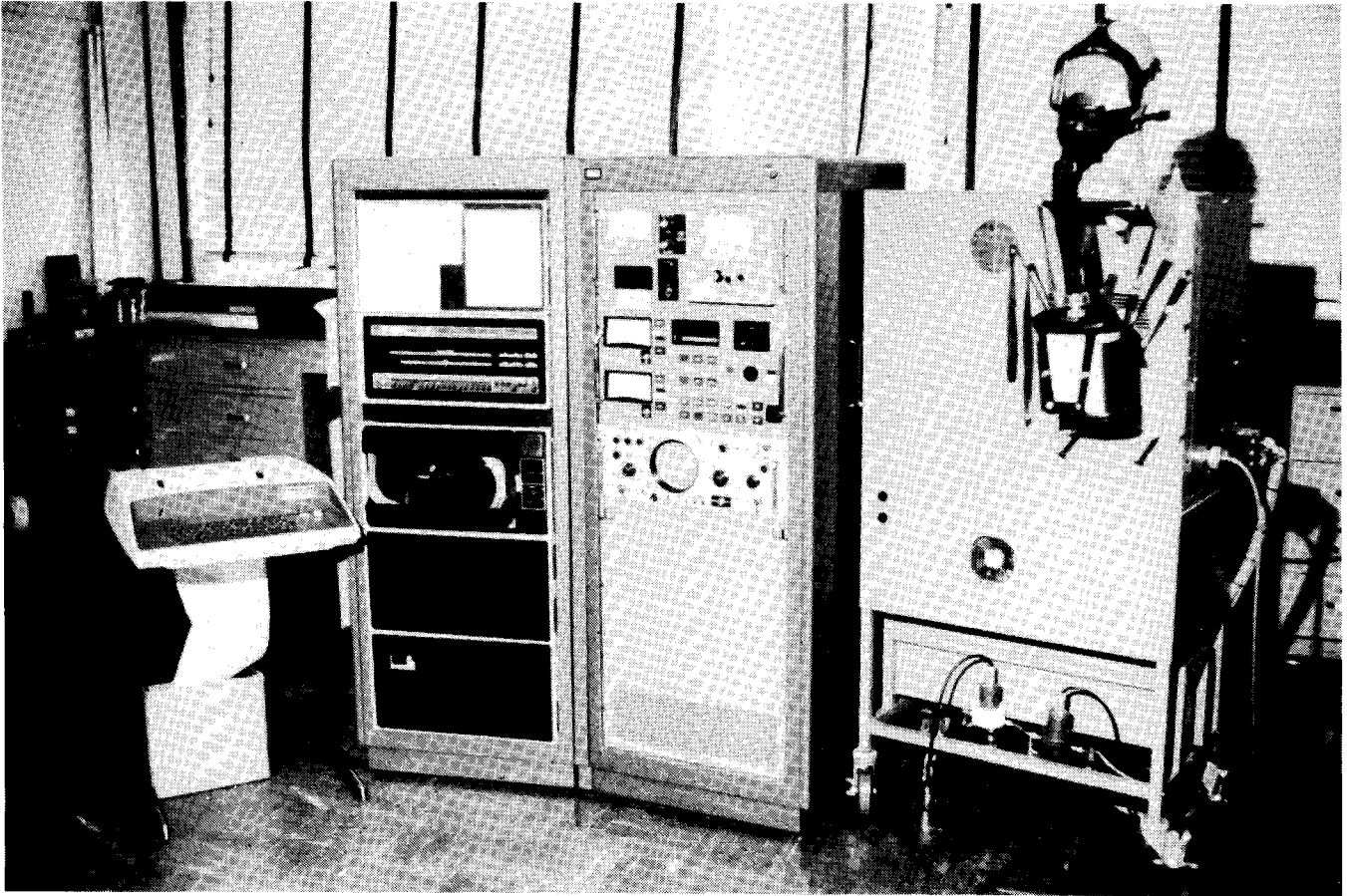

FIGURE 1.—IBM ABMS photo.

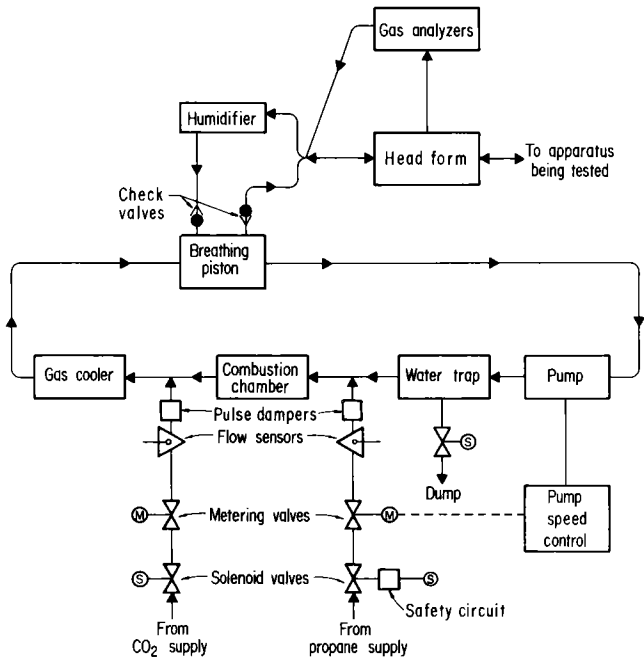

FIGURE 2.—IBM breathing and metabolic systems schematic.

those years, it was also very complicated and required continual maintenance.

The metabolism simulation by this machine was effected by the burning of propane that consumed O_2 and produced CO_2 . (See figure 2.) The breathing simulation was controlled by a variable-speed motor that was connected to a cylindrical, metal piston through linkage of a crankshaft, lever, and fulcrum. (See figure 3.) The original lung was a flexible bellows that was replaced by the nonflexible, sliding-seal piston. The tidal volume could be changed by moving the fulcrum. The functional residual capacity (FRC) was also adjustable. (See figures 4 and 5.)

One of the assets of this machine was its anatomically appropriate arrangement and functioning of components such as the simulated trachea with bidirectional flow that provided dead space. Also humanlike was the continuous simulated metabolism process. In addition, this simulator was

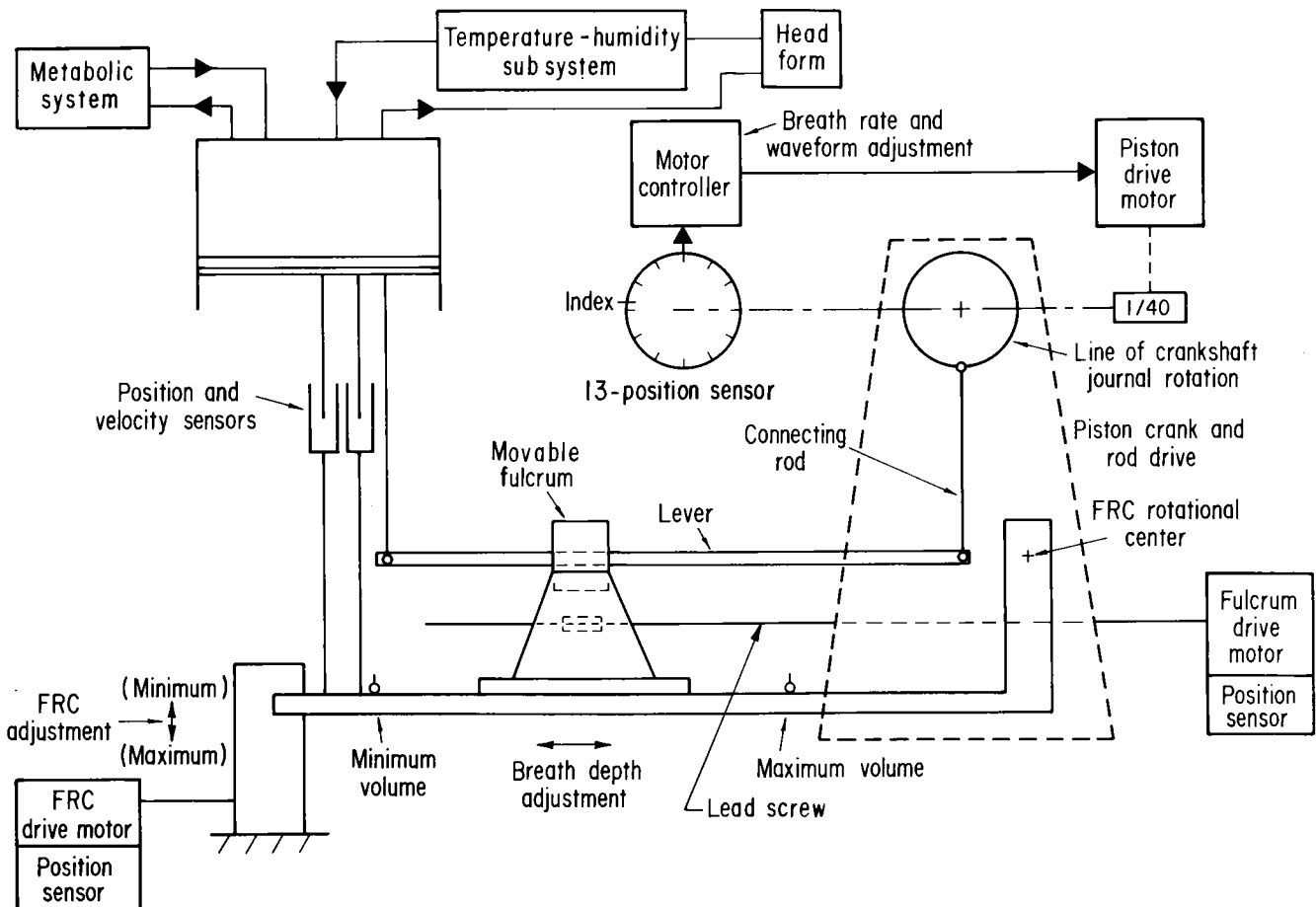

FIGURE 3.—IBM breathing-simulation system schematic.

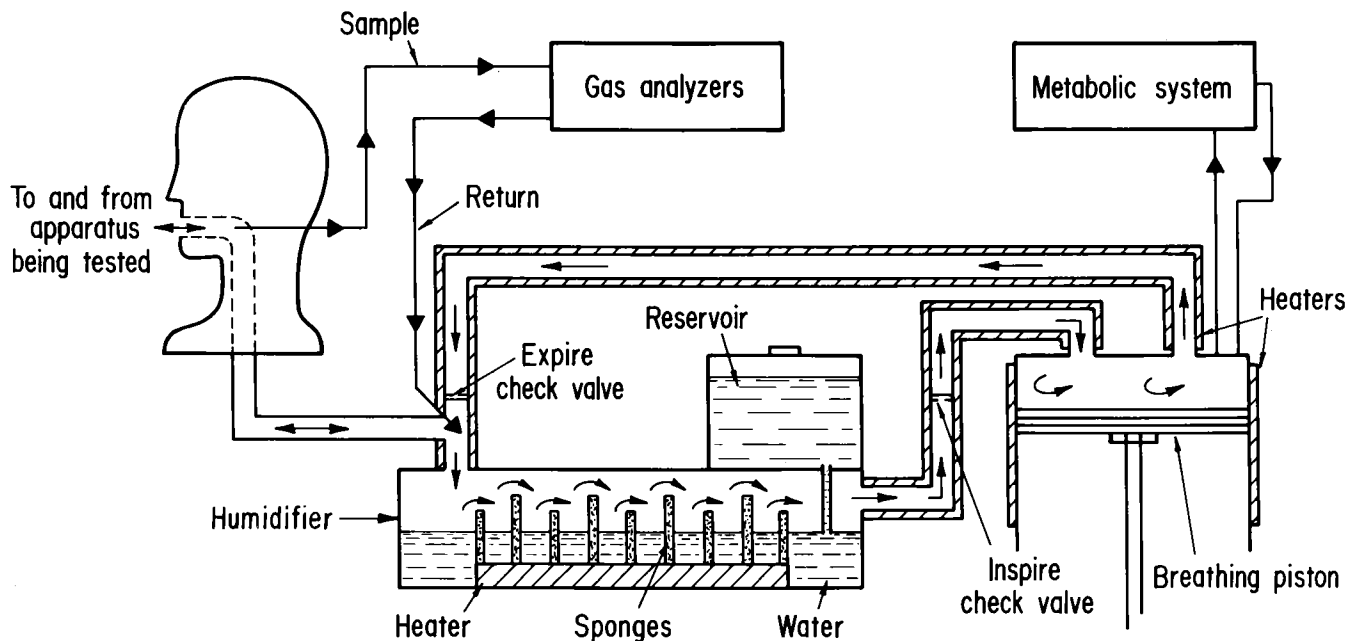

FIGURE 4.—IBM temperature and humidity system schematic.

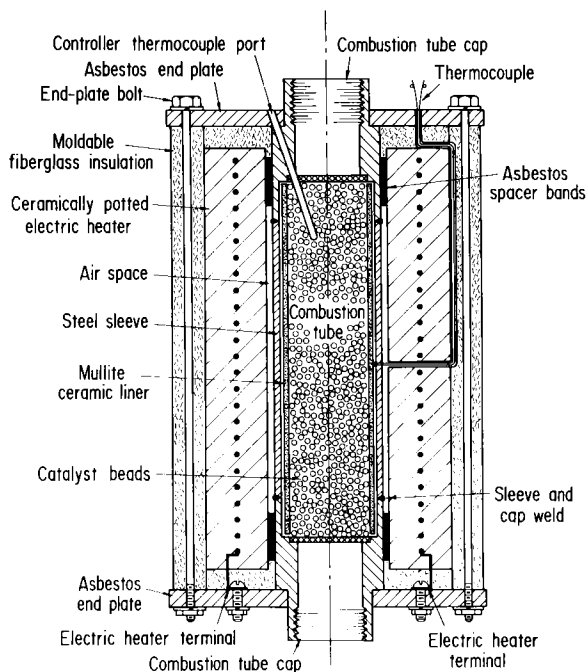

FIGURE 5.—IBM electric furnace.

more of a true closed-loop system (like a human being) than simulators that simply remove and replace gases to effect metabolism, but this was accomplished not without penalty. Control of the furnace ignition of the propane was not easy. Also, the system was very complicated with many modifications such that only

the person who used and modified it understood exactly how it worked. When that person left the Bureau, the IBM simulator was retired. Only peak values of inhaled gases could be measured with this system as opposed to average inhaled values.

For more information regarding the functioning of this simulator, refer to Bureau RI 8496.²

REIMERS MBMS

This machine was bought from Reimers Consultants of Falls Church, VA, in the spring of 1981 as a supply contract (S0308126). It was used in Bureau research and testing for 2 yr, then it was transferred to the NIOSH facility in Morgantown, WV, for its research projects. (See figure 6.)

The Reimers manual breathing and metabolic simulator (MBMS) effected metabolism simulation through cyclical removal of breathing circuit gas and replacement with CO₂ and N₂. The N₂ replacement was made necessary by the unavoidable removal

²Sparks, A. W., R. L. Stein, and J. W. Stengel. A Breathing Metabolic Simulator for Testing Respiratory Protective Equipment. BuMines RI 8496, 1980, 18 pp.

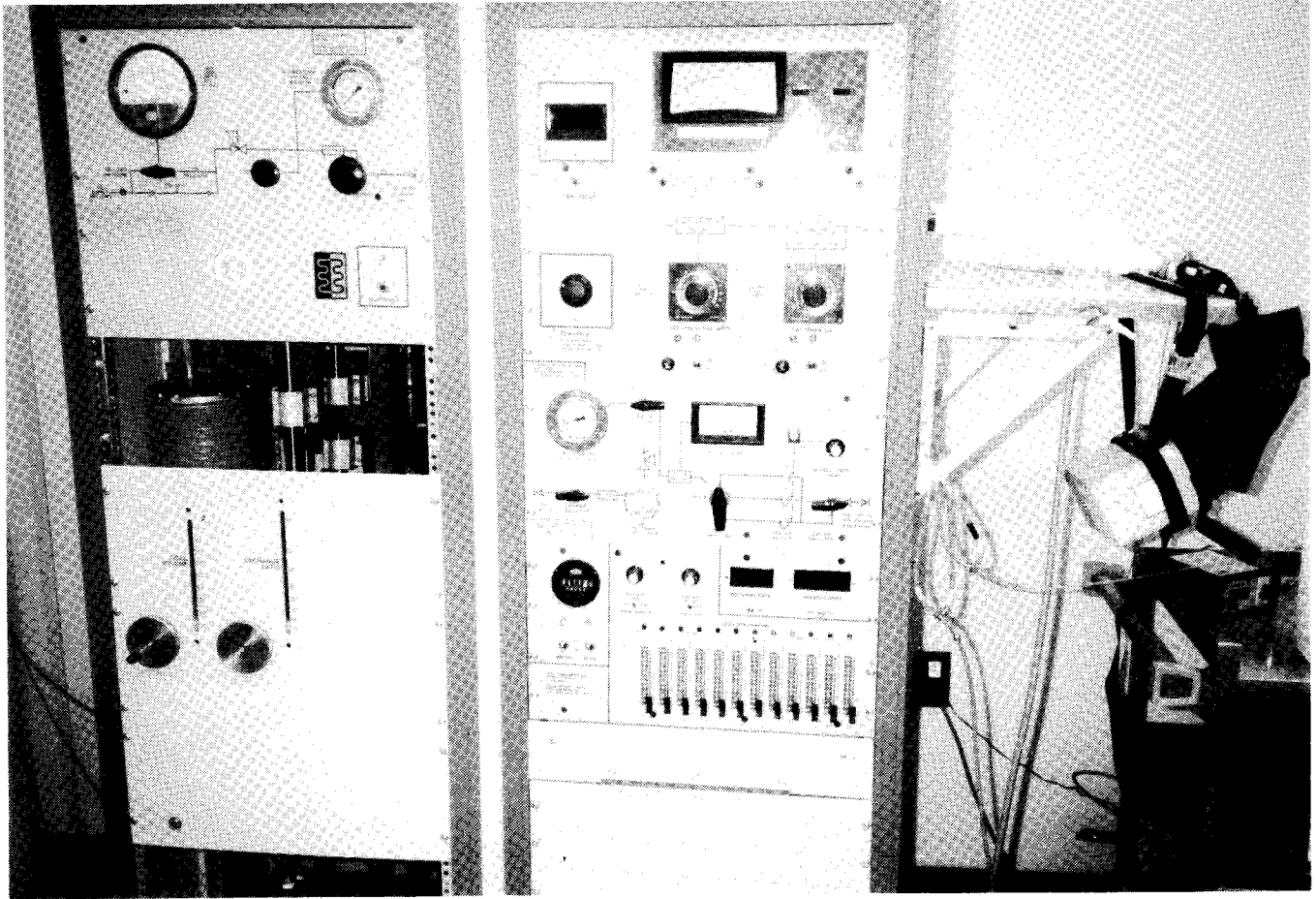

FIGURE 6.—Reimers MBMS photo.

of some N_2 in the O_2 removal process. A schematic of the Reimers MBMS is shown in figure 7. The flow loop is unidirectional and contains approximately 7 L of breathing circuit gas. Air is inhaled from the inhalation port and then mixed in the inhalation mixing box from which inhalation gas is sampled. The major portion of the gas is then inhaled into the main bellows. Upon exhalation, the gas is forced out of the main bellows into the humidifying chamber where moisture is added to the gas. From this chamber, the gas goes into an after-heater and an exhalation mixing box from which exhalation gas is sampled. The motor-driven main bellows is controlled by a series of slide potentiometers that enable the breath waveform to be shaped.

Part of the inhaled air is drawn into a smaller bellows, called the removal bellows, to simulate O_2 consumption. The quantity removed depends upon the concentration of O_2 in the inhaled gas. A quantity of gas equal to that removed is replaced by the supply bellows consisting of both CO_2 and the makeup N_2 . An additional bellows, called the balance bellows, is utilized to ensure that the operations of the removal and supply bellows do not add to the desired tidal volume. The balance bellows thus serves as a volume compensator.

The metabolism simulation, then, is controlled by the supply and removal bellows. The quantity of gas exchanged through the operations of the supply and removal bellows is dependent upon the

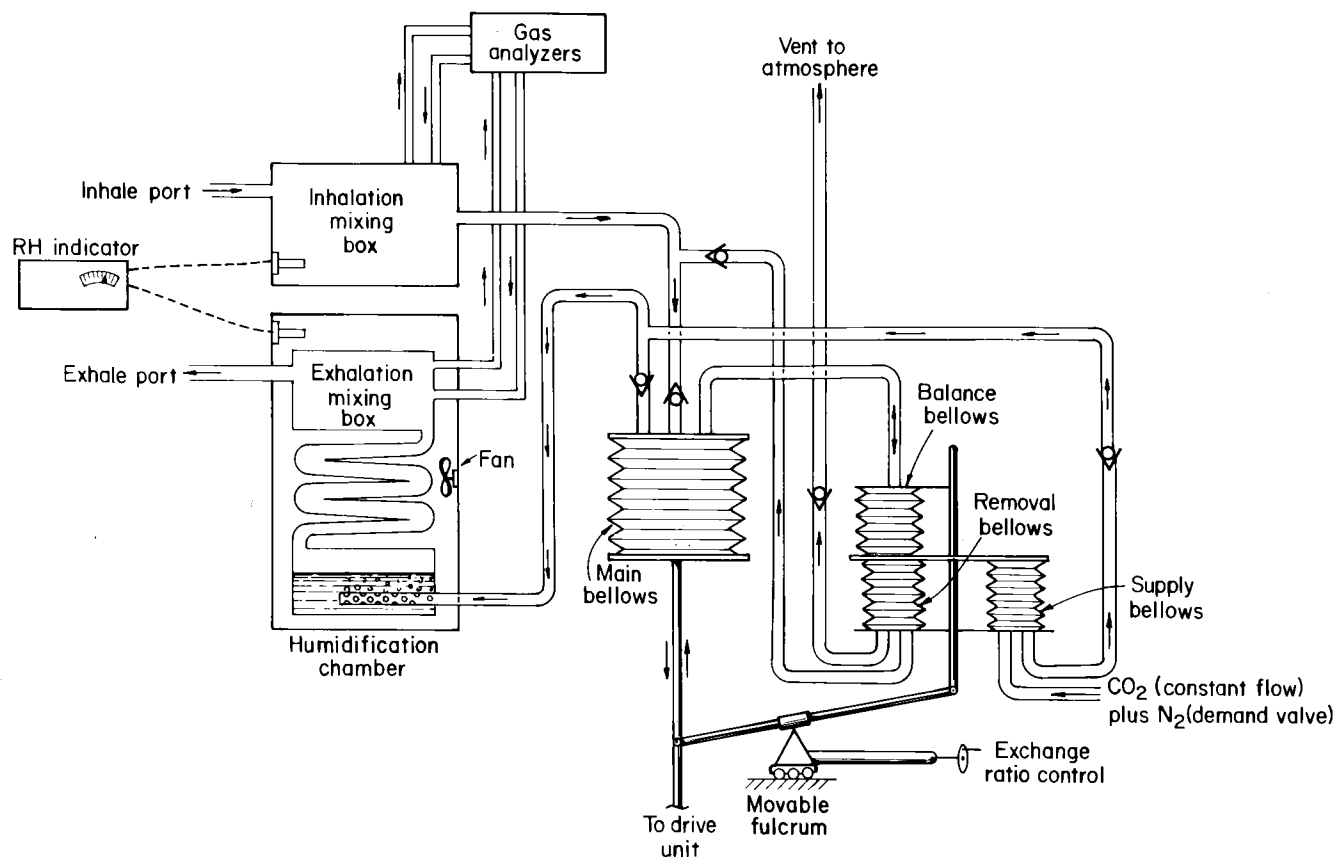

FIGURE 7.—Reimers MBMS schematic.

concentration of O_2 in the breathing circuit. If an O_2 removal rate of 2 L/min is desired and the O_2 concentration is 100%, one simply removes 2 L/min from the circuit. If, however, the O_2 concentration is only 50%, 4 L/min of circuit gas must be removed in order to remove the 2 L of O_2 .

In a much simpler process, the CO_2 flows into the supply bellows at a constant rate and is independent of the gas exchange processes. The N_2 flows into the supply bellows elicited from a demand valve as needed to complete the exchange. Thus, at an O_2 concentration of 50% (as above), and a CO_2 flow rate of 2 L/min, 2 L/min of N_2 must be supplied from the demand valve to equal the 4 L/min of gas being withdrawn via the removal bellows.

The quantity of gas exchanged in the metabolism process is controlled manually

by a knob referred to as the exchange-ratio controller. The ratio used is the removal bellows volume divided by the main bellows volume. Thus, the higher the O_2 concentration, the lower the exchange ratio. Since this is a manually controlled operation, a human monitor must carefully observe the O_2 concentration (measured by the analyzer) of the inhaled gases in the inhalation mixing box and then adjust the exchange ratio accordingly.

The advantages of this simulator over the IBM machine were that it did not use combustion of flammable gases to simulate metabolism, and that it enabled us to measure average inhaled gas concentrations. This was accomplished mechanically through its design by using a unidirectional flow loop that drew all of the inhaled gas from a breathing

apparatus into the inhalation mixing box where the gas concentrations were measured. With the IBM simulator, and in human subject testing labs, even though continual monitoring of gases may be performed, only minimal and maximal concentrations are utilized. The contribution of apparatus dead space to inhaled gas concentrations is not calculated if only peaks of gas concentrations are noted; measuring minimal values of CO_2 , for example, tells only how well the CO_2 scrubber is working and not how much CO_2 is actually being inhaled. Average inhaled values of gases tell us what concentration of gases a person would actually inhale.

One of the major drawbacks of this system was its mechanical complexity. Also, since control of the exchange ratio was manual, the user was forced to always be present during a test because O_2 concentration was continually changing. The manual exchange ratio also made it practically impossible to simulate more than one metabolic state. Further problems with the MBMS are next described in detail.

Bellows Flexibility

Because of the flexible nature of the bellows, even though it was reinforced with wire, the volume fidelity of the system was not always good. If a breathing apparatus being tested had significantly higher exhalation resistance than inhalation resistance, for example, the simulator might not be able to force the appropriate volume of gas back into the apparatus while continuing to extract the appropriate volume. This would have the effect, in the case of closed-circuit breathing apparatus, of drawing the breathing bag flat and demanding more O_2 than desired.

N_2 Fidelity

It is an assumption by design of the MBMS that N_2 in the correct quantity will

be drawn into the circuit to balance the O_2 removal and CO_2 addition processes. This, however, was not necessarily the case. Again because of the flexibility of the bellows, if the inhalation resistance of the apparatus were high and the exhalation resistance low, for example, more N_2 would be forced into the breathing circuit. Also, upon every exhalation, pressure would increase in the supply bellows causing the CO_2 flow to slow; this would reduce the quantity of CO_2 being added to the system. Since the supply bellows demanded that a certain quantity of gas be added to the system, more N_2 would then be added to make up the required volume. Both of these factors had the effect of causing O_2 concentrations to decrease because the O_2 was being diluted by the N_2 .

System Response Time

Because of the large internal flow-loop volume (approximately 7 L) and the unidirectional flow pattern, the system response time to a change in inhaled gas concentration was longer than that of a human being. This had the effect of compromising its simulation. This problem would also be carried over to the automated version of this design.

The Hypoxia Scenario

Also because of the large internal flow-loop volume, a problem surfaced with the compressed O_2 apparatus when O_2 consumption rate was greater than the constant O_2 flow of the apparatus. Upon first attachment of the apparatus, even if the simulator were inhaling 100% O_2 , it would exhale ambient air back into the apparatus since the simulator flow loop was full of ambient air. This would have the effect of diluting the O_2 concentration and filling the apparatus with mostly N_2 . Since the O_2 removal rate was higher than the O_2 supply rate, the O_2 concentration would fall at a constant rate until too low for life support. The

apparatus demand valve would not be triggered since the large quantity of N_2 kept the breathing bag inflated.

REIMERS ABMS

This machine was a result of a 3-yr development contract with the Bureau. This simulator was to automate the design of the Reimers MBMS, which was then in use. The Reimers ABMS was delivered to the Bureau in February 1984. (See figure 8.) This simulator was also to remedy the problems the Bureau had identified with the Reimers MBMS. The bellows were replaced by flexible rolling-seal pistons that were stretched to a taut condition by pulling a vacuum on their nonsystem side. It was felt that this design change would solve the N_2 fidelity

problems, but it added another system to an already complicated device. See figures 9 through 11 for schematics of this ABMS. This simulator is described in more detail by Reimers.³

A supervisory computer was used to control the functions of breathing simulation and to automate the exchange-ratio control in order to remove the correct amount of gas to simulate O_2 consumption. Temperature, humidity, and CO_2 flow were input and then controlled by computer.

The advantages of this machine over its manual version were its automated exchange-ratio control that freed the

³Reimers, S. D. The Development of a New Automated Breathing Metabolic Simulator. *J. Int. Soc. Respir. Protect.*, v. 2, No. 1, 1984, p. 170.



FIGURE 8.—Reimers ABMS photo.

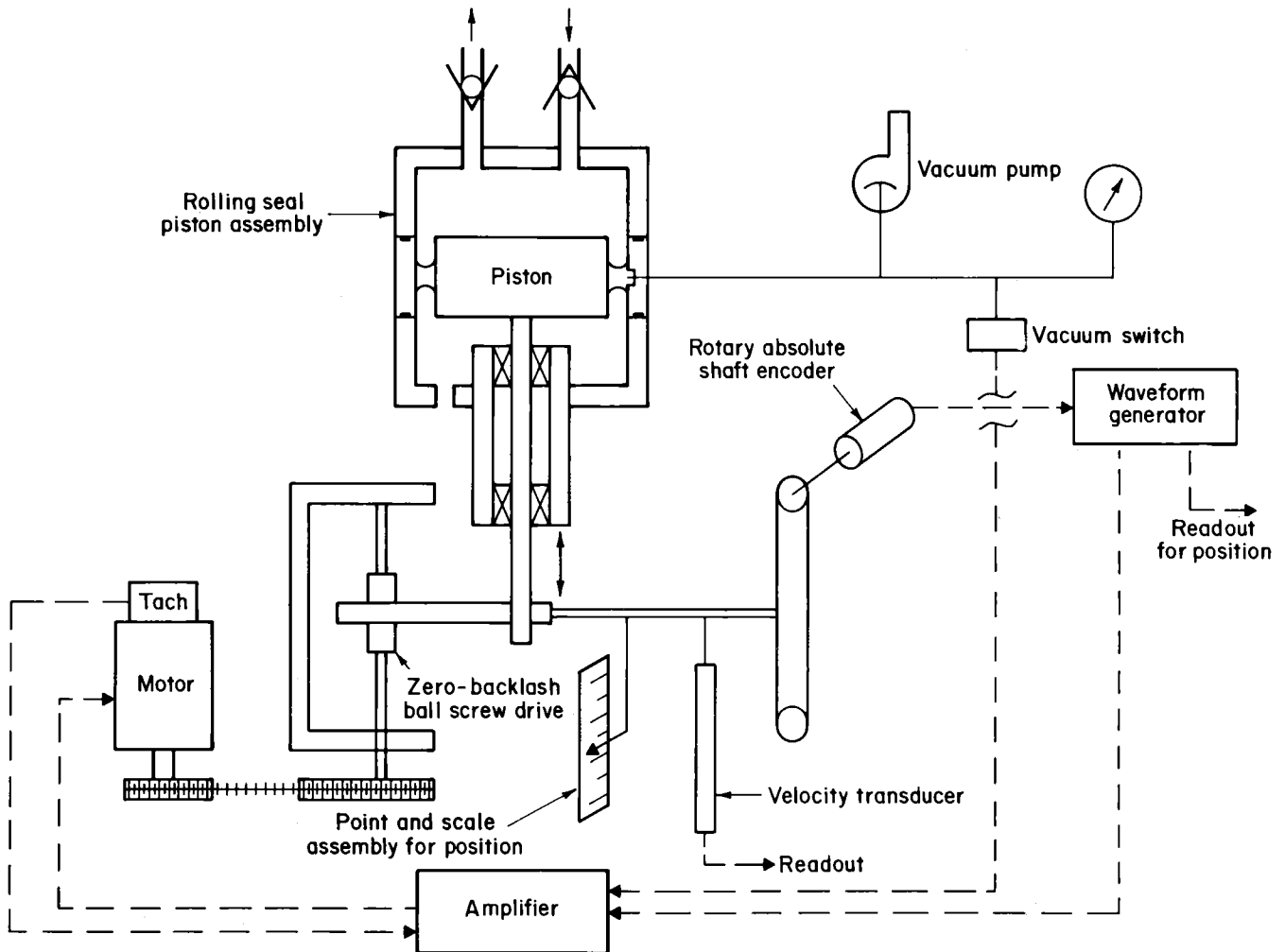

FIGURE 9.—Reimers ABMS breathing-simulation system schematic.

user from being present at all times during a test, and its capability to simulate more than one metabolic state per test.

The major problem with the Reimers ABMS was that it never worked for any length of time. At some point during a test, for some inexplicable reason, the piston would attempt to move beyond range limits and would trigger the limit switch, thus shutting down the system. The mechanical system and the computer system were designed by different persons, with the

result that effective control of the mechanical system was not achieved by the computer system.

The cause of the problem could not be isolated by either Reimers Consultants or by the person who created the computer program through contract to Reimers. The Bureau then decided to remove the computer-control system and run the mechanical system from the in-house computer. Also, the servo-motor was replaced with a stepper motor. The Bureau is currently attempting to bring the

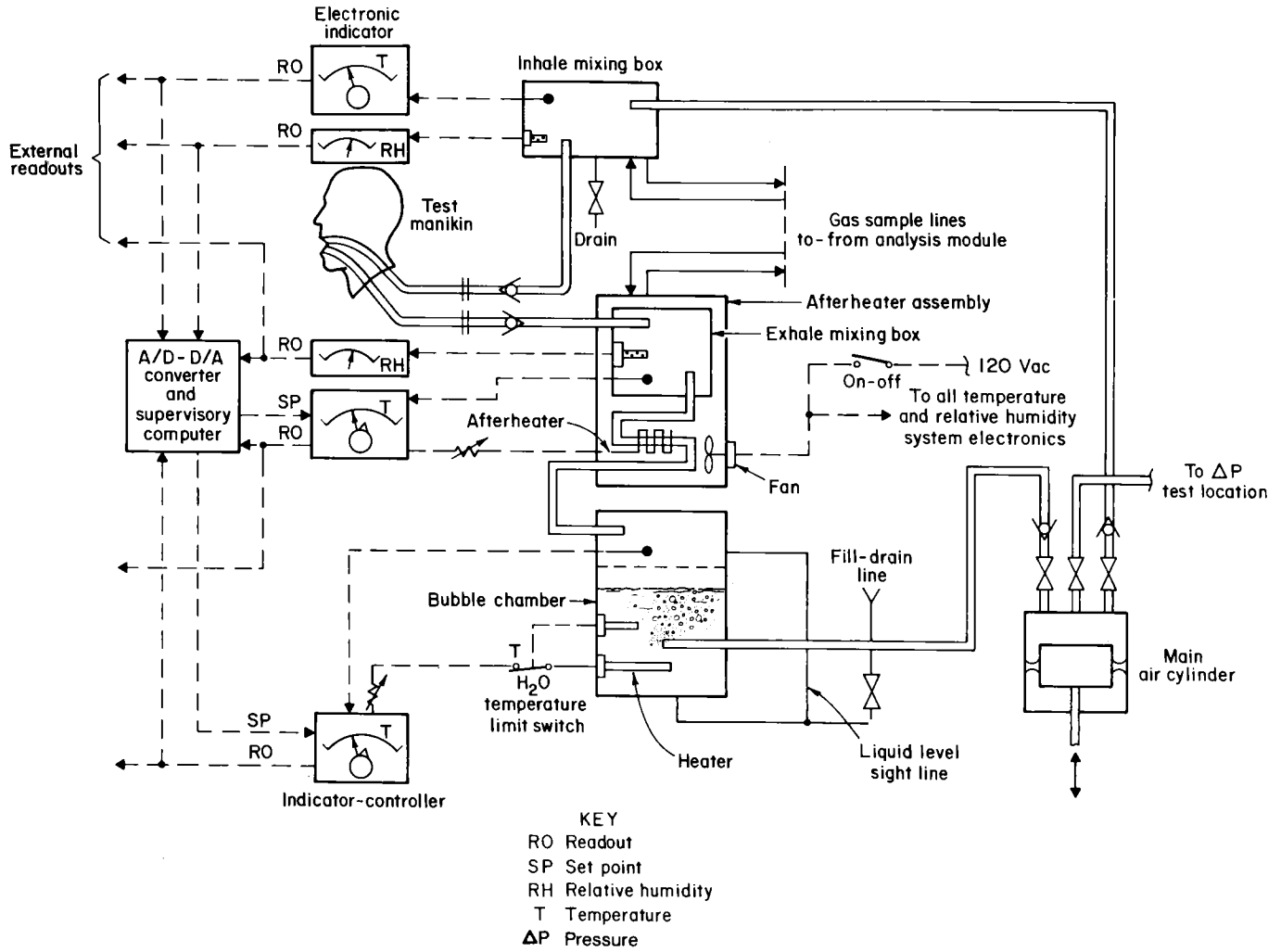

FIGURE 10.—Reimers ABMS temperature and humidity system schematic.

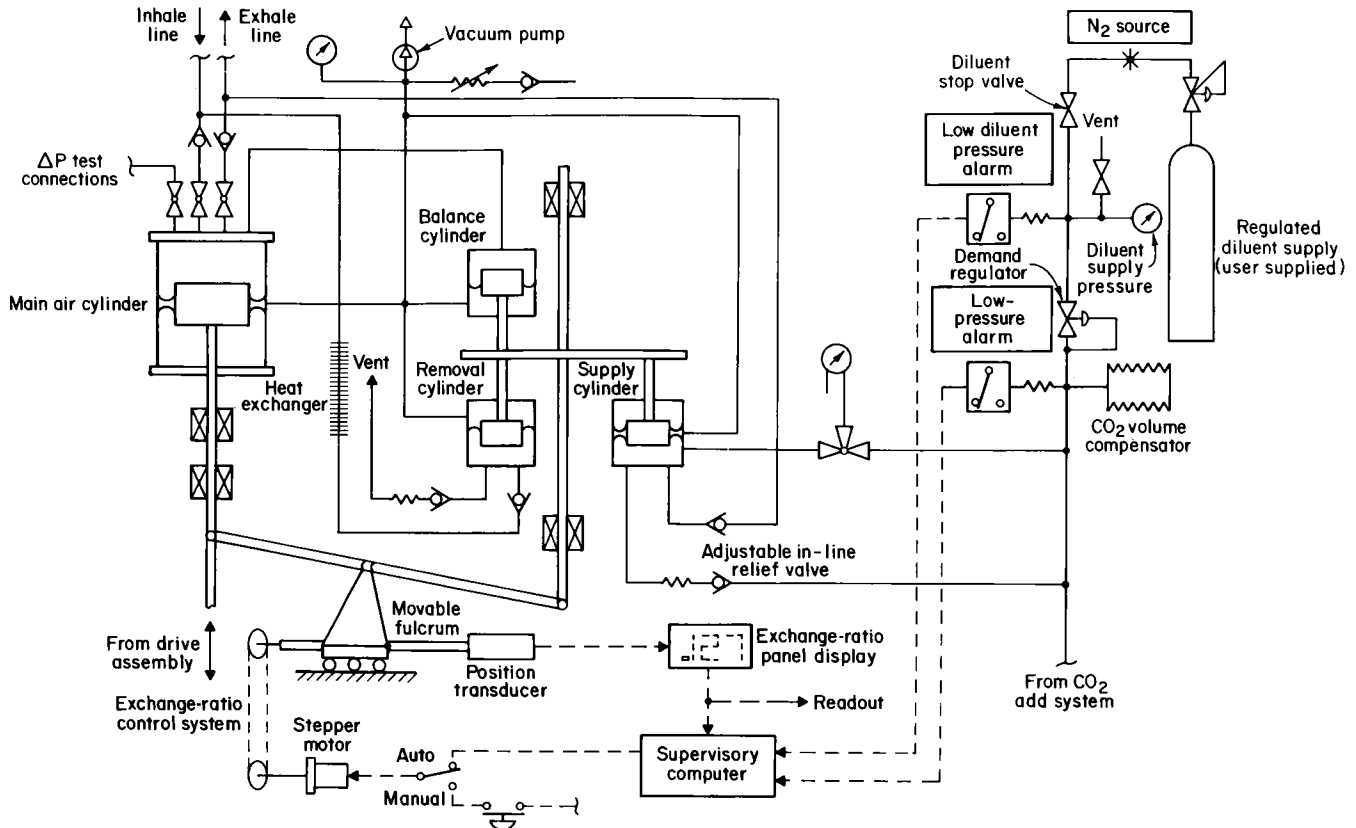

FIGURE 11.—Reimers ABMS metabolic-simulation system schematic.

Reimers ABMS to a working condition so that it may be evaluated.

DEEC INC. ABMS

This simulator was delivered to the Bureau in March 1985; it was modeled after its conceptual twin, still in use at the Noll Laboratory of Pennsylvania State University in State College, PA. The DEEC Inc. simulator is a commercially available item. The simulator at the Noll Laboratory was developed as a laboratory tool, part of a Bureau contract with Penn State.⁴ (See figure 12.)

⁴Kamon, E., S. Deno, and M. Vercruyssen. *Physiological Responses of Miners to Emergency*. PA State Univ. (contract J010092). Volume I--Self-Contained Breathing Apparatus Stressors. BuMines OFR 29(1)-85, 1984, 32 pp.; NTIS PB 85-186831. Volume II--Appendices (contract J010092). BuMines OFR 29(2)-85, 1984, 181 pp.; NTIS PB 85-186849.

The inventors have described this simulator in detail.⁵

This ABMS is presently in use at the Bureau and is being continually evaluated. We have found that, due to its physical simplicity, there is inherently less that can go wrong with it. Its complexity is in the computer software. The breathing simulation is achieved through use of a piston attached to a stepper motor that is controlled by the computer. (See figure 13.) Any shape of waveform is capable of being reproduced. At present, one can choose from sine waveforms, Silverman waveforms, or waveforms developed by Pennsylvania State University personnel through a Bureau contract, which, in the opinion of the creator of the ABMS, are more like those from human subjects.

Water is circulated to a mixing chamber on top of the piston from a heated water

⁵Volume II, page 120 of work cited in footnote 4.

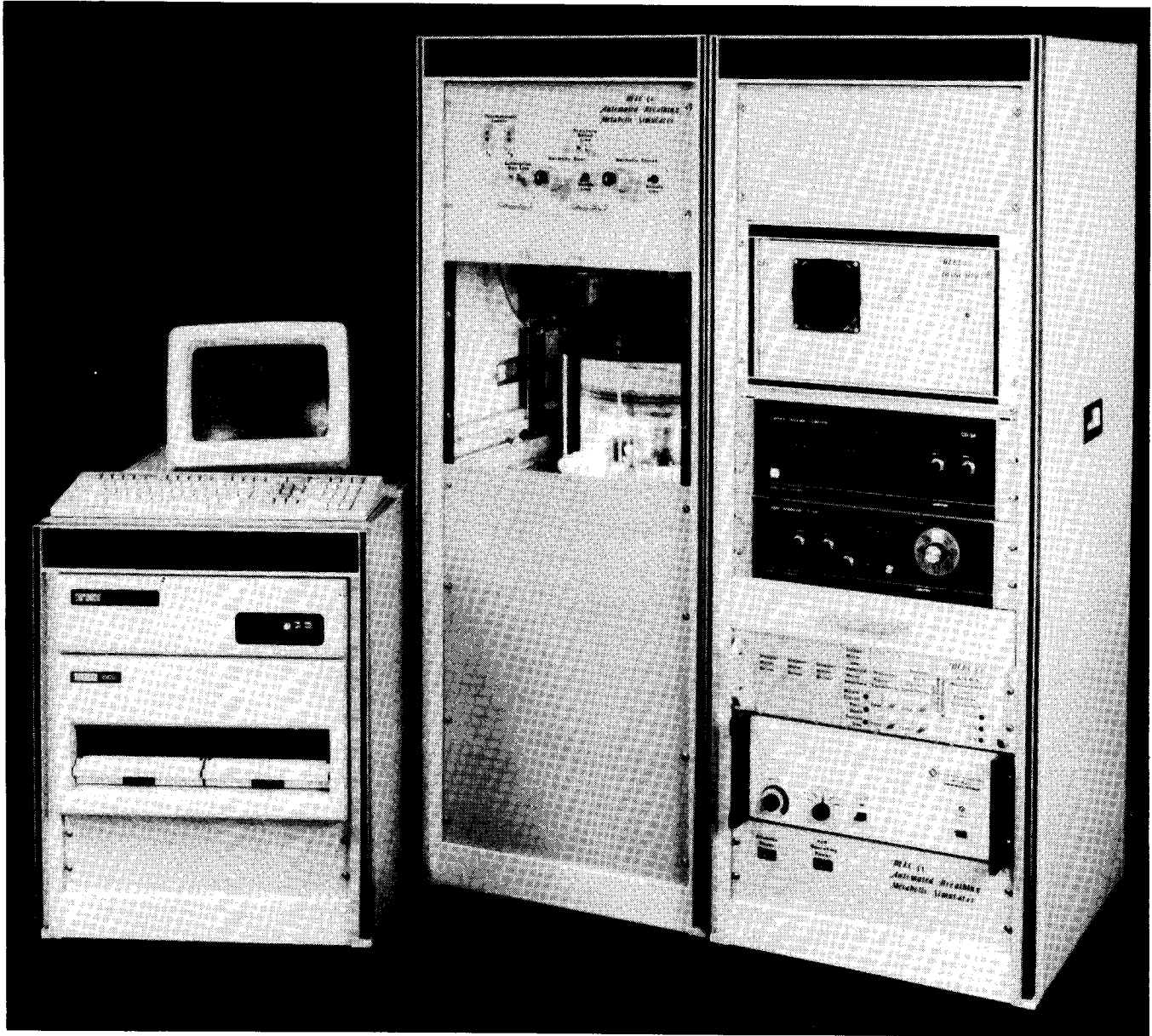

FIGURE 12.—DEEC Inc. ABMS photo.

reservoir. The heated water rains down on the piston, humidifying and heating the air. The water then drains out from the bottom of the piston and returns to the reservoir. Metabolism is simulated by continual withdrawal and replacement of gases through needle valves controlled by stepper motors, which are in turn controlled by the computer. System gas is withdrawn from a point in the trachea above the lung and through a needle valve by a vacuum pump in order to simulate O_2

consumption. If the system gas is 100% O_2 , and an O_2 consumption rate of 1 L/min is desired, the stepper motor will open the needle valve to permit 1 L/min to be withdrawn. If the O_2 concentration in the system is only 50%, 2 L/min of system gas must be withdrawn by the vacuum pump. The computer measures the system gas concentrations through gas analyzers and adjusts the needle valve with the stepper motor accordingly.

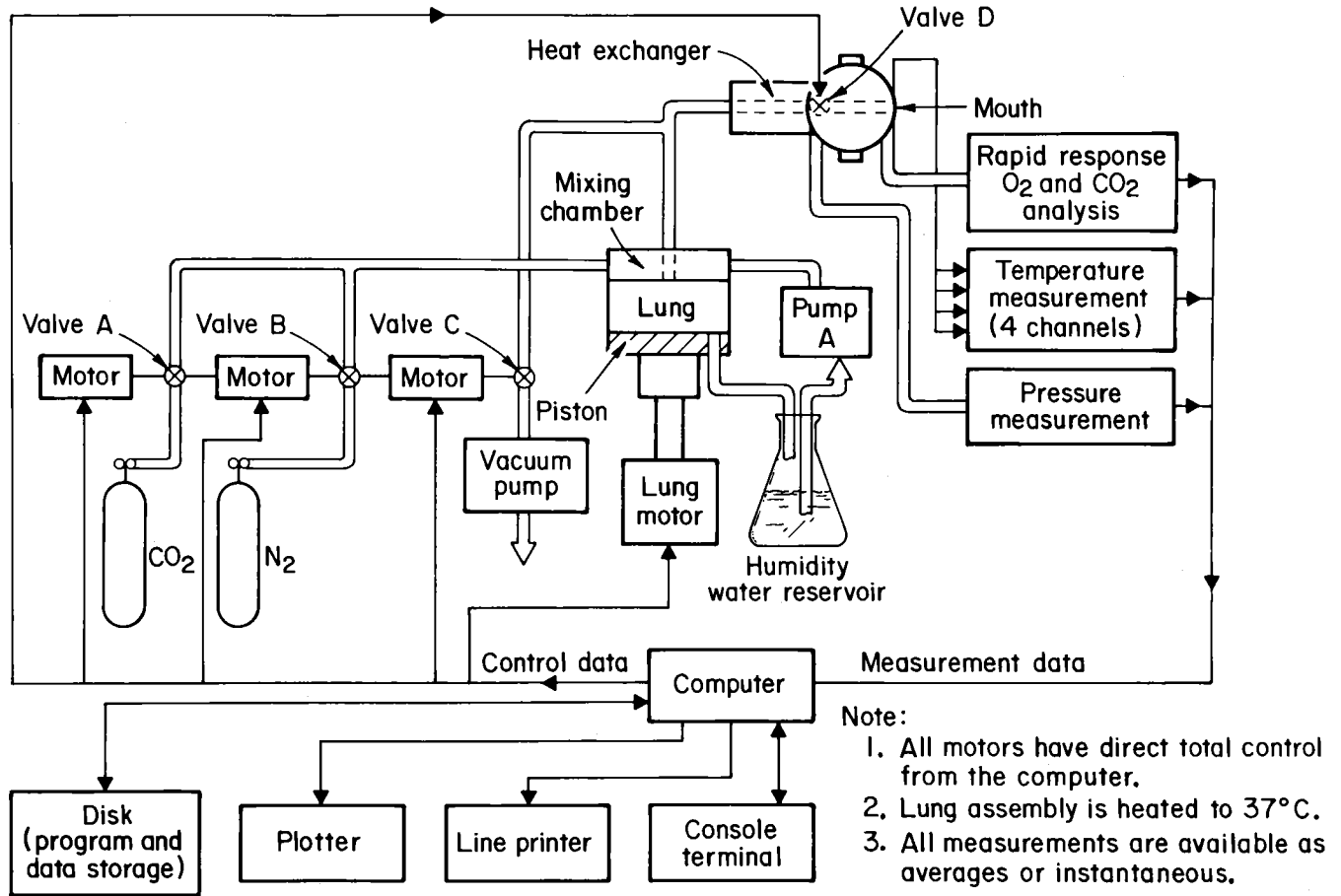

FIGURE 13.—DEEC Inc. ABMS schematic.

Since the system gas rarely reaches 100% O₂, some N₂ is removed in the process of O₂ removal. This N₂ must be replaced and is metered in through another needle valve that is also controlled by the computer. In addition, CO₂ is added to the system to simulate CO₂ production by the body through the third needle valve. The computer controls all these processes.

A unique feature of this ABMS is its ability to electronically measure average inhaled gas concentrations. Whereas the two Reimers machines measured average inhaled gas concentrations by physically collecting the inhaled gas into an inhalation mixing box that could hold

several breaths, this ABMS measures average inhaled gas levels by integrating the area under the inhalation curve of the gas tracing, weighted by instantaneous flow rate, taking into account gas transport and analyzer response time. See the appendix for a more thorough explanation of this concept.

Other features of the ABMS are

1. A humanlike bidirectional breathing flow path.
2. Variable rates of O₂ consumption (0-7 L/min), CO₂ production (0-7 L/min), respiratory frequency (6-100 breaths/min), and ventilation (0-130 L/min).
3. Metabolic rate changes of 4 per minute.

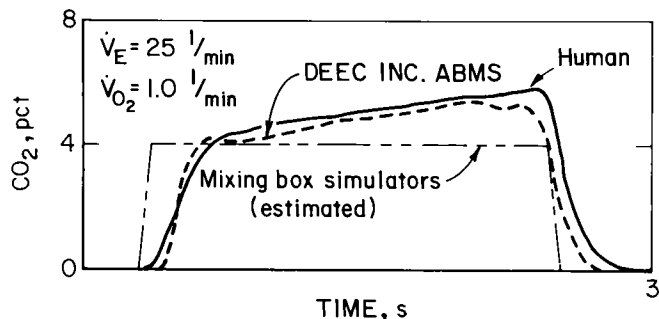

FIGURE 14.—Comparison of CO₂ breath waveforms.

4. Continuous monitoring of average inhaled O₂ and CO₂, breathing resistances, and gas temperatures.

5. Computer programs for self-calibration.

6. Fast-response gas dryer and analyzers for breath-by-breath, average inhaled gas concentrations.

7. Disk storage of complete tests.

8. Close match between CO₂ exhalation waveform of a human subject and that of the DEEC Inc. ABMS (fig. 14).

The metabolism and breathing simulation of this simulator overall have proved accurate to within 5% of desired values.

Two possible weak points in the DEEC Co. design are the indirect control of metabolic flow rates and the sensitivity of the electronic calculation of average inhaled gas concentration. The metabolic flow needle valves are calibrated for flow during a 1-h self-calibration procedure that is dependent upon steady inlet gas pressures for CO₂ and O₂ and repeatable vacuum pump performance. If

the inlet gas pressures change or the vacuum pump changes its characteristics, the metabolic flow rates will be in error.

The calculation of average inhaled gas concentrations depends upon correct measurement of gas transport and response times that are used to delay the integration of the area under the figurative gas concentration curves. If the gas transport or response times, which are measured in ms, change due to turbulence in the sample lines, the measured values will be incorrect. Turbulence could be caused by discontinuity in the sample line if, for example, two lines joined by a butt connection become slightly separated and the inner diameter of the sample line suddenly expands. Carelessness would permit these two weak points to become problems.

After further evaluation and familiarization with this ABMS, the Bureau intends to develop recommended revisions to 30 CFR 11, which details requirements for approval of breathing apparatus by NIOSH and the Mine Safety and Health Administration (MSHA). Quantitative evaluation of breathing apparatus based upon ABMS tests, rather than human subject tests, will be recommended. The performance of a breathing apparatus should be evaluated with a known, controlled input. It will be recommended that human-subject testing be used only for ergonomic evaluation. New stressor levels will be based upon recent physiological research.

CONCLUSIONS

After more than a decade of Bureau of Mines research in the simulation of breathing and metabolism, a system has been developed that meets the Bureau's goals. It can be used as a laboratory tool in both research and testing in the evaluation of breathing apparatus, especially closed-circuit types that cannot effectively be evaluated by simple

breathing machines. This automated breathing and metabolic simulator can be called upon to produce any waveform or metabolic demand that can be produced by a human subject, and do it in a repeatable manner that is precisely controlled. This tool will be used to better and more fairly evaluate breathing apparatus in research and testing.

APPENDIX.--AVERAGE INHALED GAS VALUES

Some elaboration on the concept of average inhaled gas concentrations is warranted. When monitoring the gas concentrations sampled at a position close to the mouth of a user of a closed-circuit breathing apparatus, one would observe cyclical changes: high CO_2 and low O_2 upon exhalation, and low CO_2 and high O_2 upon inhalation. A chart recording of such cycling is shown in figure A-1. What is not widely recognized is that the low reading of the CO_2 , for example, is not the concentration of CO_2 that is actually being inhaled. This is merely the lowest level of CO_2 escaping the CO_2 -absorbent canister.

The column of air being inhaled from the breathing apparatus, as shown in figure A-2, will contain some exhaled gas that resides in the dead space of the apparatus. The exhaled gas is high in CO_2 and low in O_2 ; thus, even though

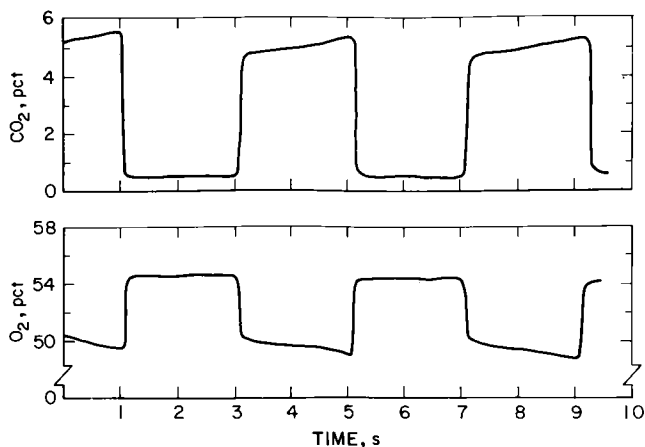
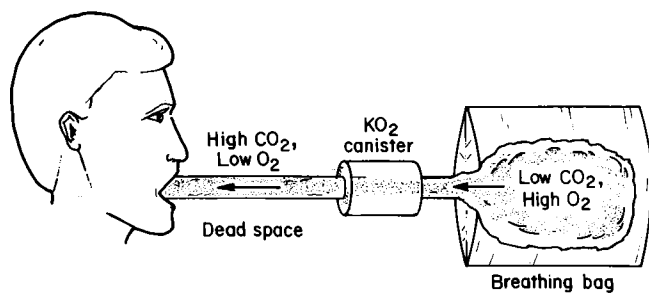

FIGURE A-1.— CO_2 and O_2 breath waveforms.



Single inhalation air column

FIGURE A-2.—Single inhalation air column.

inhalation has begun, the monitored gas concentrations will not change until this slug of exhaled air passes through the subject's mouth. This must be considered in order to determine what the subject is actually inhaling.

A chart recording of the CO_2 breath waveform, such as in figure A-1, does not indicate precisely where inhalation has begun. The drop in CO_2 , for example, indicates the point in time at which the air inspired from inside the CO_2 scrubber and breathing bag has reached the gas sampling point, been transported to the gas analyzer, and registered on the chart recorder. At some point before this time on the chart recording, the inhalation cycle began. If we knew exactly where on the CO_2 recording inhalation began, we would have a better idea how much CO_2 from the dead space of the breathing hose was inhaled. Measurement of the instantaneous flow rate would tell us where inhalation began, but the response times of the gas analyzers must also be known for correlation between the CO_2 curve and the flow rate curve.

Figure A-3 shows inhalation and exhalation cycles depicted in three ways: lung volume, instantaneous flow rate as measured at the mouth, and instantaneous CO_2 concentrations as measured at the mouth reflecting delays of gas transport time to the analyzer and analyzer response time. In this case, we know exactly when inhalation started. If we subtract the contributions of the gas transport time and the analyzer response time (300 ms) on the CO_2 curve, it would seem that all we need do is integrate the area under the curve from that point when inhalation begins until inhalation ends and exhalation begins. Exhalation can be assumed to begin 300 ms (gas transport and analyzer response time) after the point in time indicated by the lung volume cycle. The further delay in CO_2 rise, after the gas transport and analyzer response times have been accounted for, is due to the low CO_2 found in the tracheal dead space. Another factor must be considered, however, before actual average inhaled gas concentrations can be determined, and

that is the fact that the breathing flow rate is changing all the while the gas is being sampled. If, for example, a high CO_2 concentration is registered over a 100 ms time period while the flow rate is high, it indicates a greater quantity of CO_2 being inhaled than the same concentration over the same time interval while the flow rate is low. Therefore, each instantaneous CO_2 reading must be weighted by multiplying it by its corresponding instantaneous flow rate; each of these products are then added together in order to determine how much gas is actually being inhaled.

With a breathing and metabolic simulator such as the DEEC Inc. ABMS, it is easily determined when inhalation begins. The computer knows when it gives directions to the stepper motor to start

inhaling. The computer also knows what the instantaneous flow rate is because of the defined relationship between stepper-motor speed and the fixed-diameter piston; this determines flow rate. During a calibration procedure performed before each test, the DEEC Inc. ABMS measures the gas transport and analyzer response times. Then, knowing what these time delays are, it multiplies the instantaneous flow rates by the correlated instantaneous gas concentrations and adds them up over the inhalation cycle in order to determine the quantity of CO_2 or O_2 inhaled. This is divided by the calculated tidal volume to get a truly accurate average inhaled gas concentration measurement. On the DEEC Inc. ABMS, these values are determined every two breaths.

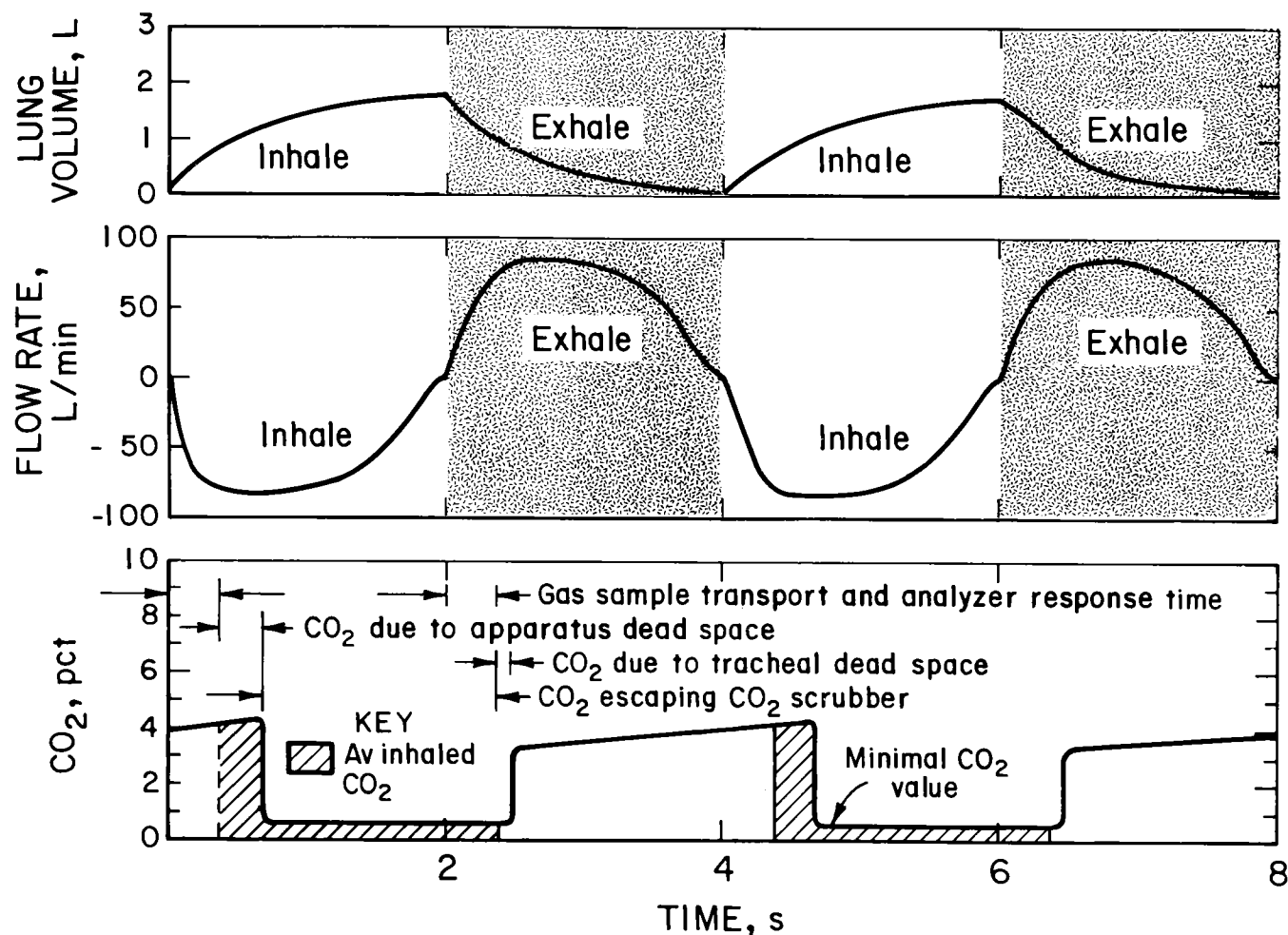

FIGURE A-3.—Minimum CO_2 value vs average inhaled CO_2 value.