

Information Circular 8645

Coal Mining Techniques in the Federal Republic of Germany—1971

**By Ernest A. Curth, Roof Support,
Pittsburgh Mining and Safety Research Center, Pittsburgh, Pa.**



UNITED STATES DEPARTMENT OF THE INTERIOR
Rogers C. B. Morton, Secretary

BUREAU OF MINES
Thomas V. Falkie, Director

As the Nation's principal conservation agency, the Department of the Interior has responsibility for most of our nationally owned public lands and natural resources. This includes fostering the wisest use of our land and water resources, protecting our fish and wildlife, preserving the environmental and cultural values of our national parks and historical places, and providing for the enjoyment of life through outdoor recreation. The Department assesses our energy and mineral resources and works to assure that their development is in the best interests of all our people. The Department also has a major responsibility for American Indian reservation communities and for people who live in Island Territories under U.S. administration.

This publication has been cataloged as follows:

Curth, Ernest A

Coal mining techniques in the Federal Republic of Germany--1971. [Washington] U.S. Bureau of Mines [1974]

54 p. illus., tables. (U.S. Bureau of Mines. Information circular 8645)

Includes bibliography.

1. Coal mines and mining--Germany. 2. Mining engineering.
I. U.S. Bureau of Mines. II. Title. III. Title: Roof support evaluation techniques. (Series)

TN23.U71 no. 8645 622.06173

U.S. Dept. of the Int. Library

CONTENTS

	<u>Page</u>
Abstract.....	1
Introduction.....	1
Acknowledgment.....	7
Mine trips and visits to plants and research centers.....	8
Coal basins visited.....	9
Mine operation.....	9
Powered roof support.....	14
Methane drainage.....	22
Dust control.....	25
Road reinforcement by roadside packs.....	27
Roof support and rock mechanics research.....	29
The longwall surveillance method.....	29
The gate road surveillance method.....	37
Laboratory testing of powered roof supports.....	41
Programs related to powered roof supports.....	43
Ground control research with mine models.....	46
Conclusions.....	48
References.....	50
Appendix.....	53

ILLUSTRATIONS

1. Map of the Federal Republic of Germany.....	4
2. Map of the Ruhr district.....	5
3. Maps of Aachen and Saar basins.....	6
4. Mine surface structures.....	7
5. Main gate road cross sections.....	11
6. Roof support at shearer face.....	13
7. Piston gage.....	17
8. Powered shield.....	20
9. Shield operation.....	21
10. Face ventilation diagram.....	23
11. Drainage holes placed from gate roads.....	24
12. Water infusion methods.....	26
13. Diagram of the far-infusion method.....	26
14. Anhydrite roadside packs.....	28
15. Face survey map.....	31
16. Roof support survey blank.....	31
17. Prop loads in terms of setting and yield load.....	32
18. Face survey diagram.....	32
19. Columnar section of strata above and below a coalbed with rock strength.....	33
20. Cavity area in front and above the support.....	35
21. General road data.....	38
22. Road survey sketch.....	38
23. Road deformation ratings.....	39
24. Printout of a tailgate road survey.....	40
25. Convergence plot.....	40

ILLUSTRATIONS--Continued

	<u>Page</u>
26. Test frame for powered supports.....	41
27. Functional outline of test frame.....	42
28. Synopsis of support testing.....	43
29. Step types.....	44
30. Pressure loss with various supply systems.....	46
31. Floor heave underground and in a model test.....	47

TABLES

1. Monthly operations statistics data.....	3
2. Key data and criteria for roof investigations.....	36
A-1. Operational data from 23 longwall faces in the Federal Republic of Germany and 1 longwall face in France.....	53

COAL MINING TECHNIQUES IN THE FEDERAL REPUBLIC OF GERMANY-1971

by

Ernest A. Curth¹

ABSTRACT

A 3-month study in 1971 of the Essen Roof Support and Rock Mechanics Research Center's program of roof and support evaluation included 25 mine trips. German miners must adopt mining methods and environmental control measures involving methane drainage and water infusion to improve productivity under severe natural conditions. Pressing problems in ground control must be solved such as cavities in front and above the supports at longwall faces and excessive convergence in gate roads. The Center developed automatic data processing methods to quantify the results of roof and support surveys and to establish criteria. Another approach to ground control is the study of mine models. The Center's laboratory has the facilities to test elements of powered roof support and whole assembled units. Face automation and roof control by powered shields are novel developments that are under close scrutiny in the field as well as in the laboratory. Though the Essen Center's roof and support evaluation techniques are tailored to the needs of the coal mining industry of the Federal Republic of Germany under conditions vastly different from those in the United States, some application may be found here, for instance, monitoring faces and roadways and preventive maintenance of hydraulic systems.

INTRODUCTION

The study included 25 mine trips and roof support evaluation techniques developed by the Essen Research Center for Roof Support and Rock Mechanics. Twenty-four longwall faces were visited in coalbeds ranging from 31 to 100 inches in thickness and pitching from 2° to 45°. The appendix lists operational data and other essential information from 23 faces with powered support. Twenty-one faces were operated by the caving method and pneumatic stowage was practiced at two faces. Hookplows or similar designs were used in 13 faces. The "Gleithobel," a novel plow design, served one face. Eight faces were equipped with ranging double drum shearers, and one face in France was equipped with a bidirectional fixed drum shearer. The roof was supported by self-advancing double frame units at 16 faces, two of which were mined with pneumatic stowage by a novel automatic side outlet system and were using

¹Mining engineer.

supports with extra long rear canopies to protect the stowage outlets in the back field. Triple frames were used at three faces with a pitch up to 45°. One rare combination consisted of chocks with a plow face. Self-advancing double chocks supported two longwalls and powered shields were installed at one face. Another face was served by double 5-leg chocks where the fifth or front jacks are combined with extensible forepoling bars and roof plates to bring support capacity close to the face where it is needed most. Prop yield ranged from 44 to 110 tons.

The coal mines visited were located in three basins, the Ruhr district, the Aachen basin, and the Saar-Lorraine field (figs. 1, 2, and 3).

German miners must meet adversities such as tectonically disturbed and pitching strata and interaction between coalbeds at close intervals. Panels are limited in length because of faults or the difficulties of keeping the roads open. The great depths where face operations take place and which average 2,700 ft cause severe environmental problems. Climatic discomfort saps the miners' physical ability to produce and often imposes a statutory working time of 6 hours. New shafts that would relieve ventilation and transportation problems are expensive to sink on account of depth and water-bearing strata atop the Carboniferous. Reject percentage is high and extensive cleaning facilities are required to prepare a marketable product.

A glance at the mine operations sheets reveals figures that catch the eye of the U.S. visitors (table 1). Absence figures of 30 percent and more are common because workers enjoy benefits such as 4-week paid vacations and wage continuity in case of illness. The large number of employees on the payroll indicates that productivity per man-shift of 3.2 to 7.3 tons of clean coal is low compared with U.S. figures, but it is still the highest in Europe. Spacious well-kept bath houses accommodate the numerous employees, many of them from foreign lands, and are a part of mine surface structures that often are impressive monuments of architecture (fig. 4).

The Bureau of Mines initiated the study of German ground control technology in an effort to go along with the recent trend towards longwall mining in the United States and to develop more competence in longwall roof control. Though the Essen Research Center's roof and support evaluation program is designed to satisfy the needs of an industry under vastly different conditions, some application of the program to U.S. conditions may be possible in such areas as monitoring faces and roadways and preventive maintenance of hydraulic systems.

TABLE 1. - Monthly operations statistics data

Mine	Production (clean coal), short tons per day	Reject, percent	Employment		Absence, percent	Sections		Productivity, short tons per man-shift
			Underground	Surface		All	Powered roof supports	
1	10,500	32.5	2,855	370	27.2	8	3	4.5
2	11,000	40	3,776	260	32	9	2	4
3	9,500	28.5	2,469	211	29	6	4	5
4	11,500	32.2	2,470	361	26.2	4	3	5.5
5	9,400	36	1,872	222	26.4	5	3	6.1
6	7,550	47	1,963	202	29.4	4	3	4.9
7	6,850	44	1,734	146	31	5	5	5.3
8	6,500	36	1,824	141	26.5	6	2	4.5
9	9,500	39.2	2,629	227	30.5	10	3	4.8
10	8,500	35.9	1,563	221	34	5	2	7.2
11	6,100	28.3	1,927	203	27	9	1	3.9
12	7,150	45	1,927	203	27.3	7	7	3.2
13	6,400	43	2,679	350	25	5	4	3.3
14	10,400	46.4	2,190	383	24.4	7	3	4.6
15	5,900	38.1	2,688	283	1.22	4	1	5.5
16	8,500	40.5	1,210	156	34.4	5	2	7.3
17	5,600	29.5	1,560	221	30.5	8	2	4.1
			1,800	170				

The figure is low because this mine instituted a 3-week miners' vacation.

Source: Zahlen zur Betriebsstatistik vom Mai 1971 (Operations statistics data of May 1971), Gesamtverband des Deutschen Steinkohlenbergbaus (National Association of the German Coal Mining Industry). Essen, 1971.

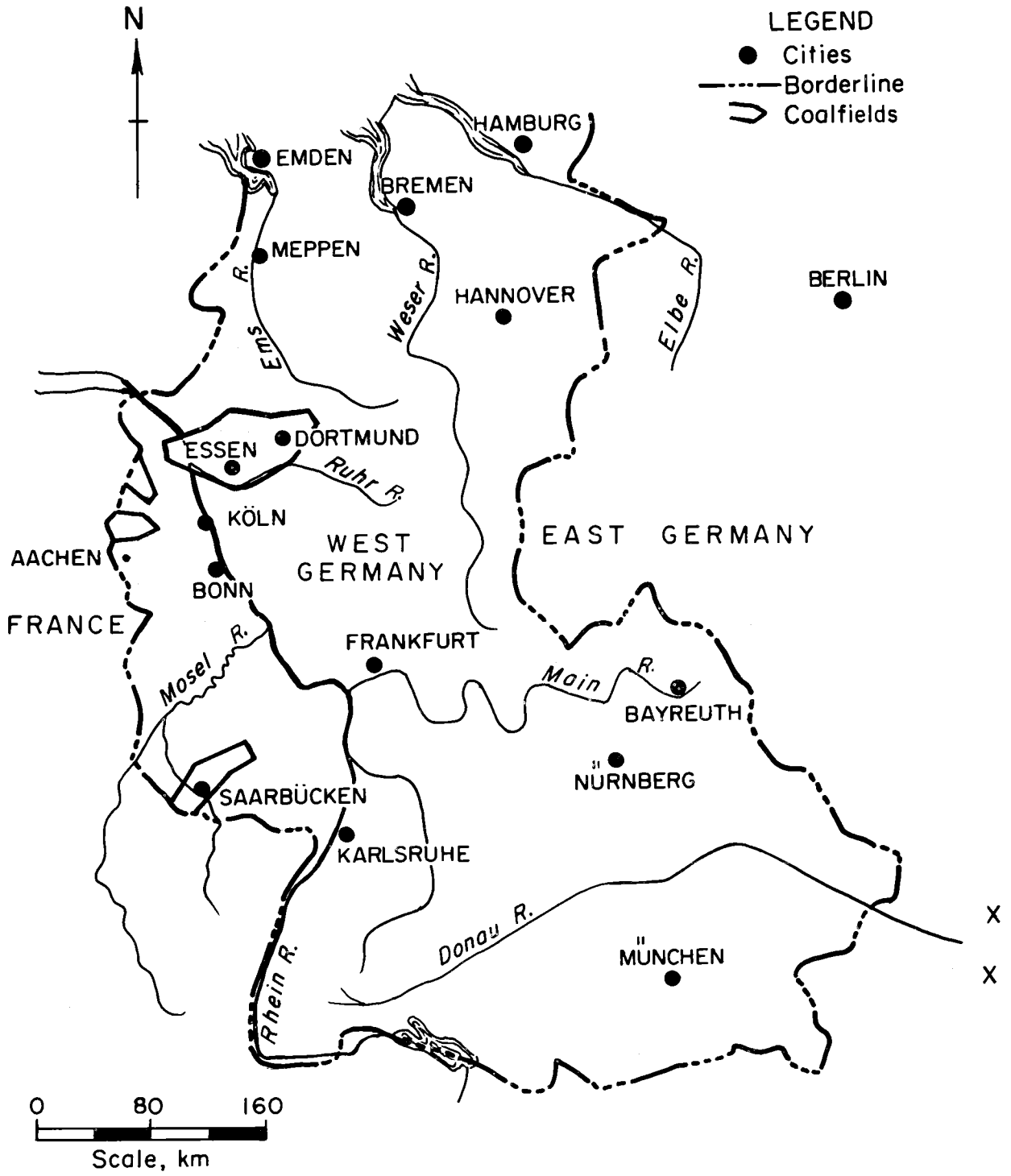

FIGURE 1. - Map of the Federal Republic of Germany.

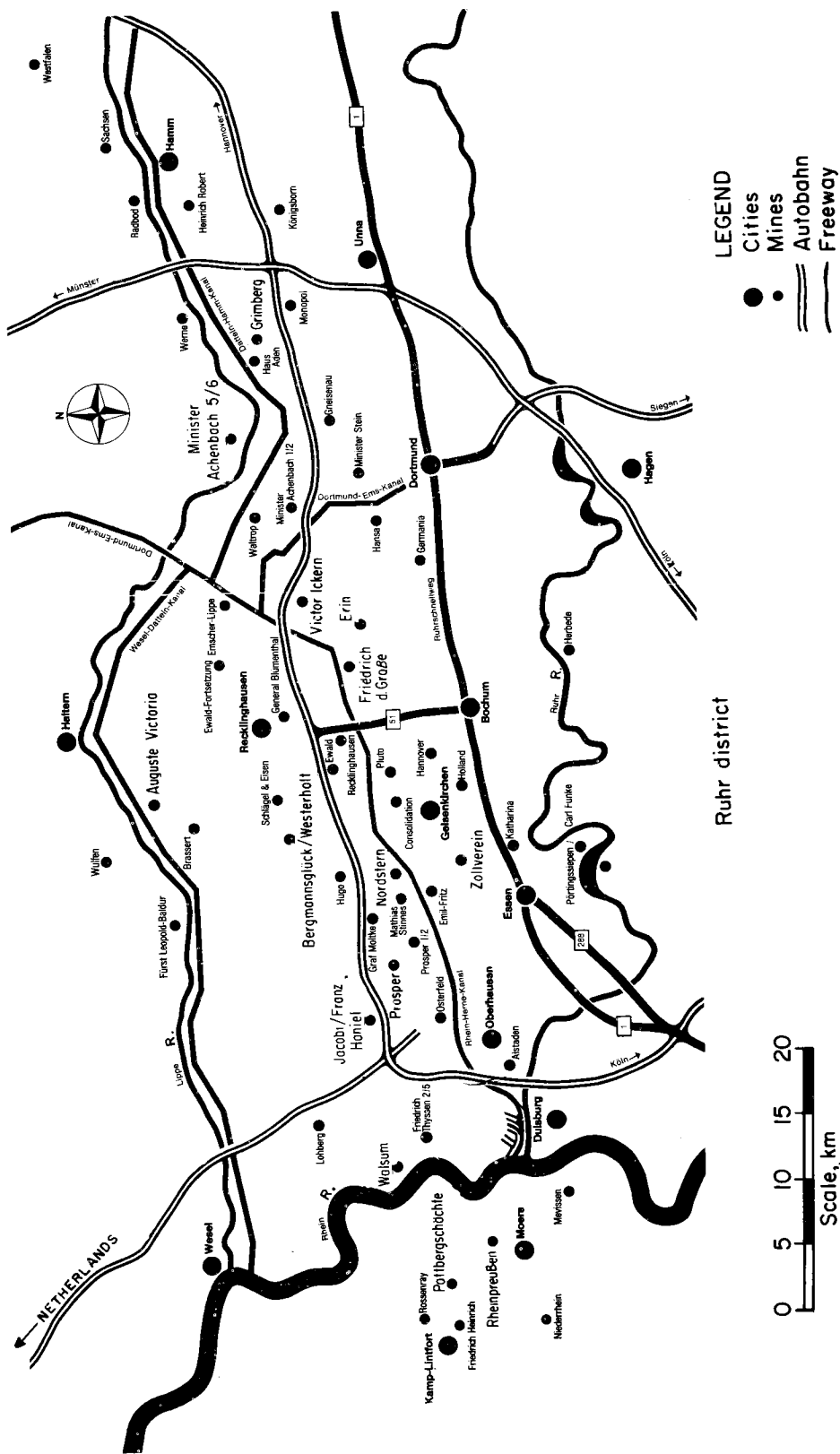

FIGURE 2. - Map of the Ruhr district.

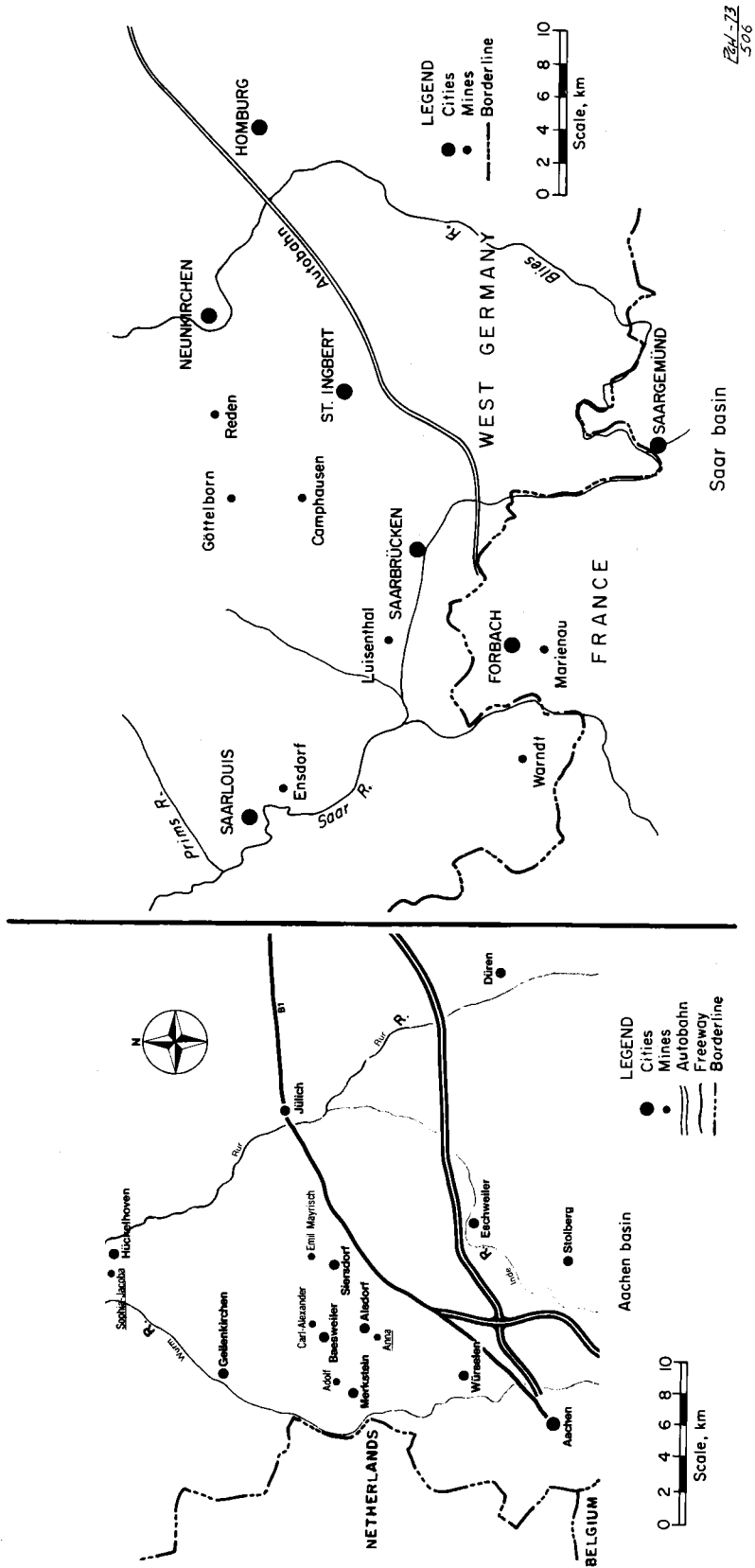

FIGURE 3. - Maps of Aachen and Saar basins.



FIGURE 4. - Mine surface structures.

ACKNOWLEDGMENT

The Bureau of Mines is indebted to the officials of BERGBAUFORSCHUNG GmbH at Essen, Germany, for making available the facilities of the Research Center for Roof Support and Rock Mechanics and for arranging contacts with the industry. In particular, the assistance and cooperation given by Dr. Oskar Jacobi, Director of the Research Center; his staff members, Dr. G. Everling, Dr. H. Irresberger, Dr. W. Götze, Bergassessor B. Rätz, engineers H. Herwig, W. Kammer, and J. Krahe, and many others of the research staff are gratefully acknowledged.

The author acknowledges the permission granted him by Glückauf to use figures 10, 12, 17, 21, 23, 25, 27, 28, 30, and 31; by Bergau-Forschung GmbH to use figures 15, 16, 18, 19, 20, 24, and 29; by Hemscheidt to use figure 7;

by Klöckner Ferromatik GmbH to use figures 8 and 9; by Gesamtverband des Deutschen Steinkohlenbergbaus to use figures 1, 2, 3, 4, and 26; Bergbau to use figure 11.

MINE TRIPS AND VISITS TO PLANTS AND RESEARCH CENTERS

Twenty-four longwall faces were studied in 22 mines of the German Ruhr, Aachen, Saar, and the French Lorraine districts (figs. 1, 2, and 3):

Mine	City
RUHR DISTRICT	
Auguste Victoria.....	Marl.
Westerholt-Bergmannsglück.....	Westerholt.
Zollverein.....	Essen-Stoppenberg.
Walsum.....	Walsum.
Pattberg.....	Kamp Lintfort.
Rheinpreussen.....	Rheinkamp.
Nordstern (2 longwalls).....	Gelsenkirchen.
Friedrich der Grosse.....	Herne.
Victor-Ickern.....	Castrop-Rauxel.
Prosper 3 (1 longwall, 2 gate road studies).....	Bottrop.
Erin.....	Castrop-Rauxel.
Jacobi/Franz Haniel.....	Bottrop.
Grimberg 3/4.....	Bergkamen.
Prosper 4.....	Bottrop.
Minister Achenbach.....	Brambauer.
Polsum shaft of Westerholt-Bergmannsglück (roof study)...	Polsum.
AACHEN DISTRICT	
Sophia Jacoba.....	Hückelhoven.
Anna.....	Alsdorf.
SAAR DISTRICT	
Reden.....	Reden.
Ensdorf.....	Ensdorf.
Göttelborn (2 longwalls).....	Göttelborn.
LORRAINE, FRANCE	
Marienu.....	Marienu.

Plants of six mine equipment manufacturers were seen:

<u>Plant name</u>	<u>City</u>
G. E. Westfalia.....	Altluenen.
Klöckner-Ferromatik (including Beien)....	Castrop-Rauxel.
Hemscheidt.....	Wuppertal.
Rheinstahl.....	Wanheim.
Becorit-Gullick.....	Recklingshausen.
Gebr. Eickhoff.....	Bochum.

Research facilities at the following centers were visited:

<u>Facility name</u>	<u>City</u>
Mining Research Co. of the Steinhohlenbergbauverein:	
Roof Support and Rock Mechanics.....	} Essen-Kray.
Dust and Silicosis.....	
Ventilation and Gas Drainage.....	
Mining Technology.....	
Mine Rescue Center.....	Essen-Kray.
Experimental Mine Tremonia.....	Dortmund.

COAL BASINS VISITED

Most of the Ruhr district mines are operated by giant Ruhrkohle AG, some by Eschweiler Bergwerksverein and one, Auguste Victoria, by BASF (Badische Anilin and Soda Fabrik). The annual production of the district approximated 100 million tons of utility, byproduct, and anthracite type coal in 1971 (22).² The most valuable coal of byproduct quality occurs within the "Fat" coal group that is also the richest coal-bearing strata with 63 ft of coal or 3 percent of a total of 2,100 ft. Coal of this group liberates much gas and is friable and dusty.

The consolidation of coal properties through the Ruhr district by the formation of Ruhrkohle AG in 1968 allowed selection of the more promising coalbeds. Areas with tectonic disturbances and steeply pitching strata were withdrawn from production and this trend is continuing. Now the share of production from coalbeds with less than 18° of pitch amounts to 75 percent of the total.

All mines of the Aachen basin except the Sophia Jacoba Mine are operated by the Eschweiler Bergwerksverein. The annual production of the district amounted to 7.5 million tons in 1971. Most of the mined coal is of byproduct quality or anthracite.

The Saar basin continues to the south into Lorraine on French soil. Except for one privately owned operation, the mines are operated by the government under the name of Saarbergwerke AG and produce approximately 12 million tons of coal of both byproduct and steam coal quality.

MINE OPERATION

Most German coal mines were developed vertically in rock by blind shafts or rock slopes, laterals, and cross-measure tunnels. But recently about 20 percent of the total production comes from mines that are developed within the coalbeds by bottom roads from which the gate roads are advanced (16). This type of mine development follows the example of the U.S. and British

²Underlined numbers in parentheses refer to items in the list of references preceding the appendix.

industries and saves the high cost of excavating in rock but is limited to flat-lying coalbeds with little tectonic disturbance.

More than 40 percent of the coal from 400 odd mechanized faces was produced in advancing longwall faces with single tail and main gate roads in 1969 (1). The system allows more positive gas control by drainage. The ribs of the gate roads next to the longwalls are mostly secured by double rows of cribbing and more recently by concretelike "blitzdammer" or anhydrite packs. Retreat mining which yields less than 30 percent of the coal produced from mechanized faces involves costly entry driving, but offers advantages such as reconnaissance of the coalbed prior to mining, cooling, and degassing of the strata about the road, and separation of entry advance work from the face production with alleviation of the inherent dust problem. The Z-system is a compromise approach that is quite often adopted. It is a method with one gate road developed prior to mining and the other driven with the advancing longwall face.

Surface subsidence considerations impose mining by stowage that involves the logistics of transporting the stowage material, mostly washer refuse, to the use locations and installing and operating expensive facilities (appendix, faces Nos. 7 and 20). The share of production from faces mined with pneumatic stowage declined to 13 percent of the total in 1969 (1).

The majority of gate roads are advanced by blasting with millisecond delay detonators and 50 to 60 holes per round drilled to a depth of 10 ft. The muck is loaded by slushers or side dump loaders into conveyors. Most gate roads are kept ahead of the advancing longwall faces by 50 to 150 ft. Only a few continuous miners and entry driving machines are used in Germany to drive roadways for retreat mining.

Most roadways are supported by yielding arches. Roadways with trapezoidal cross section are supported by steel sets and reinforced by center posts. Ring or elliptic shape supports are used where floor heave destroys any other type of support. Installation of supports on shorter centers is more effective in controlling ground stress than heavier steel shapes. Load-bearing capacity of roof support in roadways should not be less than 1.5 tons/ft² of the roof area (4). Support by roof bolting has not found much application and, owing to the hardness of the strata, more stopers than rotary bolting machines are used (19). Bolts are installed in a radial pattern on 30- to 40-inch centers crosswise and lengthwise. They usually are 7/8 inch in diameter, 6 to 7 ft long, resin-anchored over the full length and combined with steel straps or channels and posts. In France, roof bolts are used more frequently than in Germany. The French mine inspection authorities require simple sag measuring stations to be installed with the roof bolts at 50-ft intervals. The measuring arrangement consists of a wood plug with a wire attached to it. The plug is pushed into a borehole to a depth of about 7 ft and the wire is stretched by a weight. Sag of the strata below the plug can then be measured.

By necessity roads must be driven with large cross-sectional areas of 100 to 200 ft² to conduct the ventilation current and to accommodate auxiliary

vent tubes for the road head ventilation, a monorail, pumps, control stations, conveyors, and water or rock dust barriers (fig. 5). The roads must be kept open by taking bottom and retimbering if excessive convergence by roof sag and bottom heave takes place. Many roads are used twice and then require a great deal of maintenance.

In many mines, mine cars of 1- to 5-ton capacity are still hoisted to the surface in multidecked cages. But the trend is toward skip hoisting. The most modern installation is the skip hoist at Haus Aden Mine with a payload of 30 tons per skip. Also the tendency is to replace main line track haulage by main line belt conveyors and underground storage bunkers near the skip shafts. Traction for track haulage is provided by diesel and battery units and some compressed air locomotives. Haulage by trolley locomotives is subject to severe statutory restrictions and limited to rock tunnels remote from any coalbeds. One fully automated track haulage system is in operation.

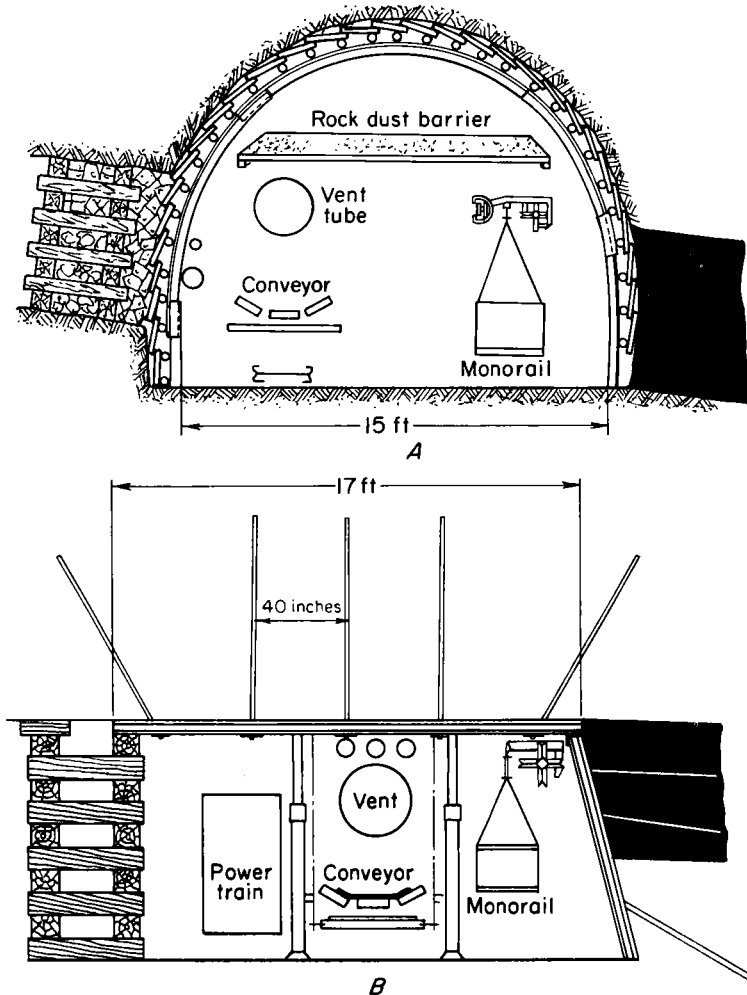

Stage loaders and belt conveyors carry the coal from the faces over belt slopes to mine car-loading stations, some of which are automatic, or to blind shafts where the product is lowered to the haulage level through spiral chutes and then dumped into mine cars. Floor heaves and grades prohibit the use of tracked or rubber-tired vehicles for supply and man transportation in most mines. Instead supplies are hauled to the faces by monorails with rope haul. Diesel locomotive-pulled monorails are used in some mines (appendix, face No. 4). Another type of supply transportation is rope-hauled vehicles on special easy-to-install track (appendix, face No. 6).

Men are transported by locomotive-pulled, covered man trip cars that shuttle between shafts and work areas on a time schedule. Shifts are staggered and workmen are coming and going all day. Riding belts is

FIGURE 5. - Main gate road cross sections: A, Support by arches; and B, roof-bolted road near face end.

permitted at many mines where provisions are made for such items as illuminated man trip platforms with railings; reduced belt speed; emergency stop cables along the belt line in easy reach of the rider; warning signs; adequate clearance; and baskets to catch a person and stop the belt, should he pass the platform without getting off. Traveltime to and from the faces takes as much as 2 hours per round trip in many mines because of the time involved in moving so many men through shafts and blind shafts.

Most mines have traffic display panels where lights indicate the movement of traffic so that the dispatcher can direct the entire mine traffic from his control booth at the shaft bottom.

More than 70 percent of all mines in Germany have mine control centers at the surface where such data as equipment running time, empty and loaded cars at loading points, air velocity, CH_4 and CO concentrations at critical locations are collected and transmitted for readout (2, 21). The average center has 200 channels for data transmission. Proper function of each electric circuit, the pump stations, and loading and discharge of the storage bunkers can be monitored also. Some centers are equipped for remote control of pump stations, belt conveyor lines, and coal storage bunkers.

Approximately 80 percent of the mechanically mined coal in Germany is produced by plows and the balance by shearers. Plows are preferred because the equipment is simple, the product is coarser, and operation is not as dusty as with shearers. High-speed or "overtake speed" plowing at plow speeds of 300 to 400 ft/min with conveyor speeds of 100 to 300 ft/min is the plowing technique most frequently used in German mines (30). This technique was developed to put an even load on the conveyor and improve the production potential of the system. Two and three speed plows and conveyor drives are available to permit a number of combinations for the best result.

Most plows are of the hook plow type with the plow chain guided at the gob side of the conveyor. A novel development for improved horizon control is the "Gleithobel," a plow with ramp plate guidance and with the plow chain concealed under the ramp plates along the face side of the conveyor. Horizon control is provided by hydraulic lifts that are mounted to the gob side of the conveyor and can tilt the panline to lift or drop the plow. In-situ plowability of a coalbed can be assessed either by a penetrometer or by measuring the impact of a rebound instrument, the "Schmidt" hammer.

Shearers are used in firm coal that does not lend itself to be plowed and in coalbeds thicker than 6 ft. The shearer operation also offers better horizon control where the floor rock is soft. The shearers at modern German faces are ranging double-spiral drum types that cut 24- to 28-inch webs and are operated with 1,000 volts. An operator-carried radio command set is widely used for remote control of the machine. The one-web-back method accomplishes support of the exposed roof as quickly as possible. The powered support is advanced immediately after the shearer has passed. The conveyor is then snaked over, and to make room for it, the shearer track must be cleaned quickly (fig. 6).

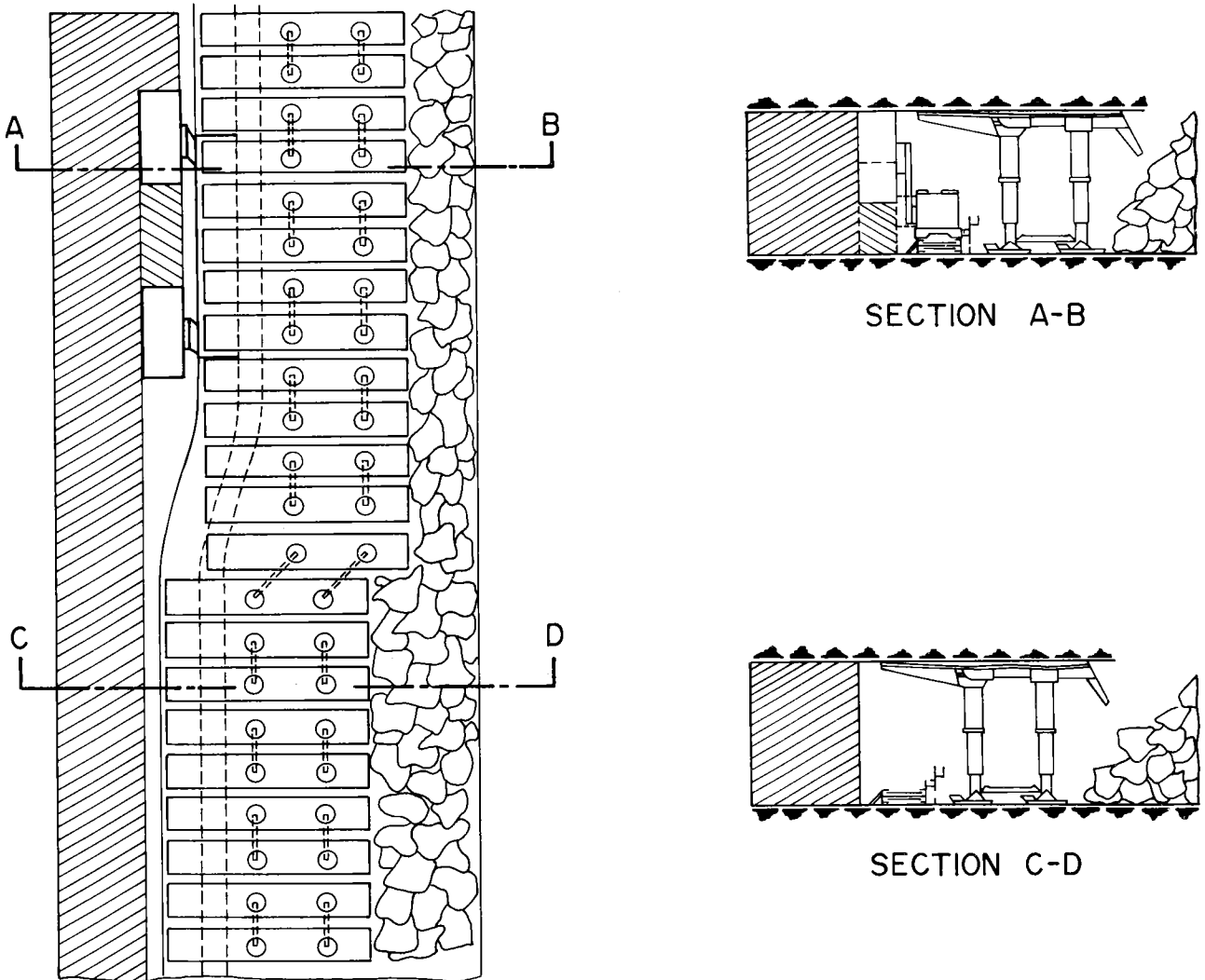

FIGURE 6. - Roof support at shearer face.

The following face cleaning systems are in use:

1. Small shuttle plows traveling along the face and being pulled by chains (appendix, face Nos. 6, 10, 17, 22).
2. Regular hook plows that cut out the bottom part of the coalbed and turn the coal up onto the conveyor (appendix, face Nos. 18-19).
3. Cowls with shaped ramp plates of the Walsum system that guide the coal from the face onto the conveyor without using any moving parts (appendix, face No. 4).

Single, double, and triple chain-armored face conveyors are in use. The conveyors are anchored by stations that must be of very strong design where faces are pitching steeply (appendix, face Nos. 12, 21). In-face anchorage has been developed in an effort to supplement the usual anchor stations at

the face ends. It consists of a number of hydraulic rams, about five, that are distributed along the face, chained to the conveyor at one end and fastened to support unit bases at the other end (appendix, face Nos. 1, 16, 21).

Machine stables are eliminated in many modern high-production faces. The conveyor and plow drives with the powered anchor stations must then be placed into the gate roads. Where faces are equipped with ranging double-drum shearers, either of two techniques, the one-half face or the end-loop method, are applied to cut out the face end corners and to sump into the new cut.

Tubing for the auxiliary road head ventilation, 28 to 32 inches in diameter, and a monorail to take supplies to the road head add to the congestion at the face ends. Ground stresses build up at these critical locations. Abutment forces along the face combine with those along the road and impose a heavy load on a road support that is already weakened by removal of legs or arch segments while the longwall face passes through. Single hydraulic jacks substitute for the removed rib support and rows of jacks with Vanwersch bars reinforce the roof of the area about the face ends. Vanwersch-VW-bars are steel bars with serrated flanges to engage the prop head and thus keep the props from sliding away. They come in 32- to 49-inch lengths and can be joined together to form a continuous beam.

POWERED ROOF SUPPORT

Only about 40 percent of the 1970 production originated from faces supported by powered units (9). Obstacles to mechanization are poor control of a roof that tends to cave in front and above the supports and unreliability of the support under such loads. Even now roof control of 20 percent of the faces with powered supports is inadequate insofar as cavities occupy more than 30 percent of the roof area. A longwall with such severe roof problems is no more efficient than a face supported by single props. This indicates the magnitude of the risk German mine operators take when they introduce powered supports and why quite often they are hesitant to make a decision. To minimize the risk, only coalbeds with known good and uniform conditions are usually selected for mechanization. A daily face advance of not less than 10 to 15 ft should pay for the costly investment.

Most powered supports in Germany are of the double frame 4-prop self-advancing type that are not affected by relative movement or "breathing" of the conveyor while the plow passes by. Some triple frames are used in coalbeds higher than 7 ft and pitching more than 20° because of better stability. Chocks, and recently shields, are commonly used with shearers. A few plow faces with roof support by chocks are the exception.

The statutory minimum support capacity A for caving longwall is calculated by the following formula in coalbeds under 18° of pitch (20):

$$A = 1.6 \times 2 \times 2.5 M \text{ Mp/m}^2,$$

$$A = 8 M \text{ Mp/m}^2,$$

where Mp/m^2 = Megapond per squaremeter (1 Megapond = the force exerted by 1 metric ton),

M = thickness of coalbed in meters,

2.5 = specific gravity of rock in Mp/m^3 (Megapond per cubic meter),

1.6 is a safety factor,

and the factor 2 allows for caving of the roof strata to a height of twice the thickness of the coalbed.

This formula reads in the British system:

$$A = 0.24 M \text{ ton/sq ft,}$$

where M = thickness of coalbed in feet.

For instance, if a coalbed is 6 ft high, the statutory support capacity must be not less than

$$A = 0.24 \times 6 = 1.44 \text{ tons/sq ft.}$$

The support capacity in tons/sq ft of a powered unit is calculated by,

$$A = \frac{n \times S}{(L + e) c} \text{ tons/sq ft,}$$

where n = number of props in a unit,

S = setting load, tons per prop,

L = length of canopy, ft,

e = roof exposed between canopy tips and face, ft,

and c = unit centers, ft.

The setting load S is a function of the hydraulic system pressure that ranges between 2,000 and 4,000 psi. S varies from 50 percent to 85 percent of the rated load to yield of a prop and is assumed to be 65 percent in most calculations.

For instance, if a prop is rated to yield at 77 tons, and

$$S = 0.65 \times 77 = 50 \text{ tons,}$$

$$n = 4,$$

$$L = 11.5 \text{ ft,}$$

$$e = 2 \text{ ft,}$$

$$c = 4 \text{ ft,}$$

the support capacity of a unit is,

$$A = \frac{4 \times 50}{(11.5 + 2) \times 4} = 3.7 \text{ tons/sq ft.}$$

A support capacity of 2 to 3 tons/sq ft is considered to be adequate in Germany, and Jacobi and others think that a higher capacity is not needed and may be harmful in breaking weak shale (9).

The following is a synopsis of support capabilities:

Props

Single and double telescoping

Fully encapsulated or open construction

Retraction by weight, spring or hydraulically

Rated to yield at 44 to 110 tons

Load indicator attached to the control valve block (fig. 7)

Hydraulic lift 20 to 40 inches and more for coalbeds thicker than 7 ft

Extension above the range of hydraulic lift by mechanical or hydraulic means: 10 to 24 inches

Centers: direction of face advance approximately 4 to 5 ft, normal to advance 2.5 to 3 ft

Stabilization normal to the strata, allowing for a deviation of 10°: by spring arrangements, by hydraulically powered centering scissors, by a support structure lined with rubber rings.

Floor structures

Foot plates for each prop or bases for two props of a frame

Spring-connected structures to provide capability of overcoming uneven ground with up to 10-inch-high steps

Rigid bases for chocks

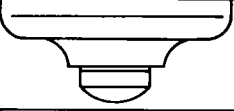
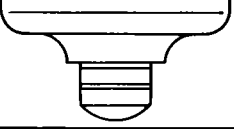
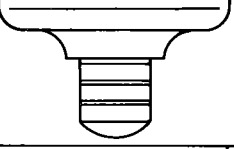
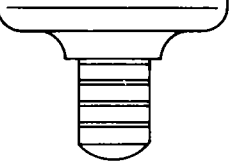
Indication of marking pin	Nominal prop load		
	40 Mp	60 Mp	100 Mp
	0	0	0
	10	15	22,5
	20	30	45
	30	45	67,5
	40	60	90

1 Mp = 1.1 short tons

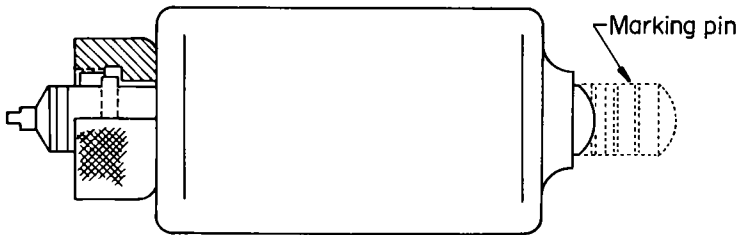

FIGURE 7. - Piston gage.

Canopies

Width 15 to 20 inches; some chock canopies are 42 inches wide; the capability to overcome roof steps and cavities requires tilting of 20° to 28° in the direction of the face and of 15° to 20° sideways relative to prop; the capability is provided by spring attachments and universal joints at the prop heads

Front cantilever: 5 to 7.5 ft in length (prop center to canopy tip)

Rear cantilever: 20 to 28 inches often with rock deflector and flushing shield; up to 6.5 ft long for longwall faces with pneumatic stowage

Structures: rigid--strong support, but unfavorable roof contact (11); single jointed--good roof contact, but forward roof control may be lost if the joint forms a peak under a large cavity; articulation limited by a squeeze joint that blocks peak formation, but allows bending in the opposite direction to have more roof contact

Immediate Forward Support (IFS) designs that provide forward roof contact and high tip load: upswept spring steel canopies; articulation by a joint inby the front legs of a chock and a ram to swing and hold the front cantilever against the roof.

Shifting rams for double and triple frames

Advance steps 16 to 40 inches

Single floor rams

Double floor rams one above the other

One floor and one top ram to provide stability of the unit in coalbeds higher than 6 ft

Normally the canopy of the advancing frame is dropped; but special design of the control valves provides for advancing while the canopies keep contact with the roof or even under slight pressure

Method of shifting triple frames

The center frame advances a full step; the side frames follow

Conveyor shifting ram

Stroke 24 to 40 inches

Available with a stroke adjustment by increments of one-quarter of an inch

Alinement of frames

Rods between units and conveyors

Ropes between foot plates and conveyor

Alinement of chocks

Provided by the shifting rams

Steering cylinders

Between props, also combined with top shifting rams

Between canopies of adjacent support units in high coal

Controls

Always from adjacent units

Valve blocks are designed on the modular principle and equipped with the yield pressure cartridge and a simple load indicator

Available also single lever control with "deadman" feature

Travel track

The safest travelway is the field between the front and rear props. However, the only path open for travel through some types of support is the front track between the front props and the conveyor. Crawling pans that permit travel along the face are then provided in low coal.

Powered shields

Two operations with Hungarian shields and legs and hydraulics by a German manufacturer were conducted in 7- and 8.5-ft coalbeds with very weak roof that had posed severe difficulties to mining with single props and pneumatic stowage (appendix, face 10, and figure 8).

The canopy is joined to the breaker shield by a strong hinge pin. Two props support the breaker shield at midheight and the breaker shield is hinged to the 40-inch-high gob shield that is bolted to the stiff floor plate. A conveyor carrier rests above the floor plate and a double acting shifting ram is mounted between the gob shield and the conveyor carrier (fig. 9).

In the base position the canopy supports the roof directly at the face, and the conveyor carrier is pushed against the face. Then the shearer removes the upper bench of the coal. The shearer begins its run from the center of the coal face and cuts towards one end at high speed. The shields are pulled up to the face, one by one, as soon as the machine has passed. At the face ends the machine reverses its motion and cuts now the bottom bench out. Behind the shearer the rams push the conveyor carrier toward the face. A shuttle plow cleans up the loose coal from the face and lifts it 16 inches from the floor over the upper edge of the conveyor carrier into the conveyor. The conveyor carrier should dip at an angle of 4.5° to the shield floor plate in order to counter its tendency of climbing on top of the slack coal while being rammed to the face.

A great advantage of shields compared with conventional powered roof support is their stability (10). It is a 3-jointed system that is kinematically determinate and can easily advance with the canopy contacting the roof or even under slight pressure. All other powered supports are 4-jointed kinematically indeterminate systems and need holding springs or other devices to lend stability to the structure. But the minimum open cross-sectional area of 50 sq ft in 8 ft working height severely limits ventilation, and high air velocities will cause entrainment of respirable dust. Maximum open area is only 72 sq ft.

Automatic operation

This type of operation is in the experimental stage at Monopol mine and at the Essen Research Center's laboratory. It is an air-over-hydraulic operation. Sensors with pneumatic cylinders are attached under the front cantilevers. They keep contact with the face and initiate the advance of the frame when needed. Keeping the jacks normal to the strata is another function performed by the system. A pendulum controls the pneumatic part and, whenever the jack deviates from the vertical position, the pendulum initiates corrective action that is impressed on the hydraulic circuits feeding laterally acting rams to return the prop to the original position. Advantages of an automatic system are limitations of men exposure and roof support with minimum delay by fractional steps of advance (12).

Mandatory tests

These tests are performed at a testing center maintained by the State North Rhine Westfallen in Dortmund to satisfy regulations for the approval of

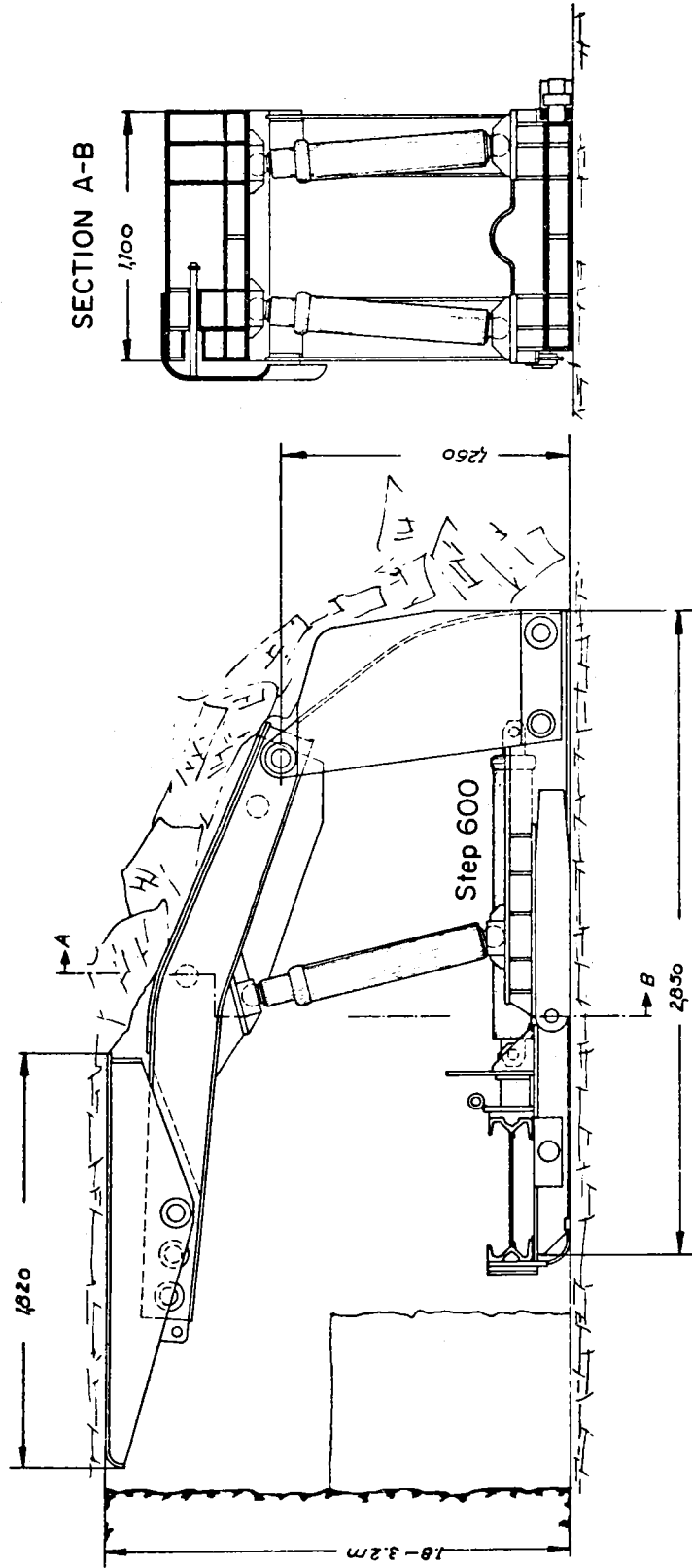

Dimensions in millimeters

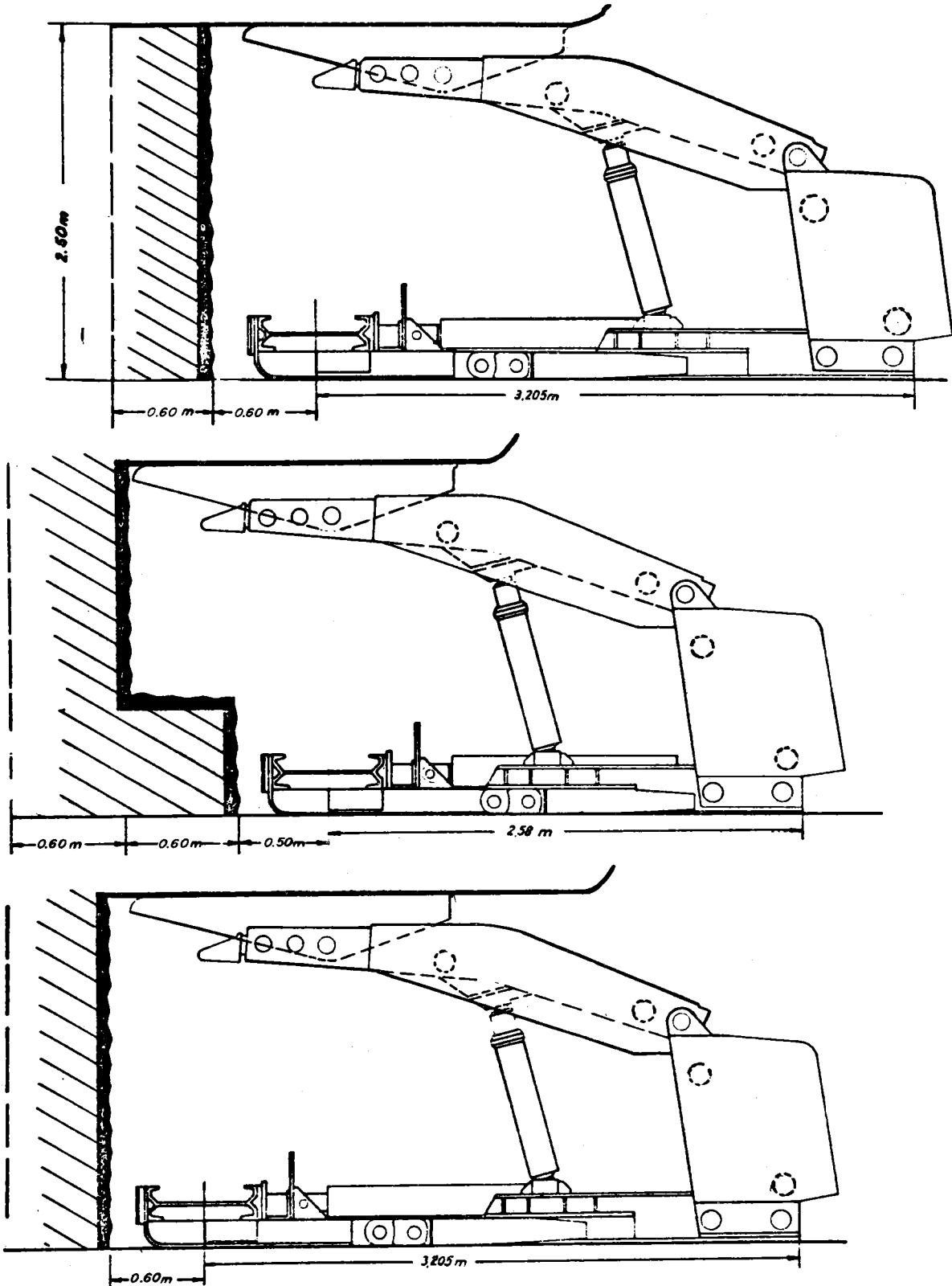

FIGURE 9. - Shield operation.

steel or light metal elements of longwall face and entry supports. In such tests, for instance, props that are extended to their ultimate length are loaded centrally and excentrically. Also lateral forces are exerted and the prop is subjected to a chock load in simulation of a mountain bump. The quality of the steel used in the different parts also is verified.

METHANE DRAINAGE

Methane emission severely limits production. German engineers calculate the maximum allowable production F_v in tons of clean coal per day by the following formula (23):

$$F_v = \frac{6048 \cdot m \cdot b \cdot w \cdot c_{m \max}}{n \cdot u \cdot q_{CH_4}} \text{ t/d (1 t = 1.1 (short) tons),}$$

where m = coalbed thickness in m (1 m = 3.28 ft),

b = width of open longwall field in m,

w = air velocity in m/sec (1 m/sec = 200 ft/min),

$c_{m \max}$ = the maximum statutory methane concentration in percent,

n = number of working days per week,

u = a fluctuation factor,

and q_{CH_4} = gas emission in m^3/t (1 m^3/t = 32 cu ft/(short) ton) of clean coal.

The width b of the open longwall field is determined by roof conditions and the type of support. The width averages 13.5 ft for powered supports. The air velocity averages 400 ft/min, but may attain 800 ft/min and more in some operations. However, 400 ft/min is the threshold velocity above which aerodynamic dust entrainment takes place. The maximum statutory gas concentration, $c_{m \max}$, has been 1 percent in Germany since 1900 and work in a concentration of 1.5 percent may be permitted by special approval. Work in a concentration of 2 percent is permitted in France where gas control plans with field instrumentation and transmission of data to a control center are in effect.

The fluctuation factor u is the ratio maximum concentration to minimum concentration in a week and ranges from 2 for 1 production shift per day to 1 for 3 production shifts per day.

The gas emission q_{CH_4} affects production more than any other parameter. Ventilation records of German mines show that gas emission varies with the pitch of the strata, the coal rank, and the coal basin. Flat and moderately pitching coalbeds from 0° to 35° liberate more gas than the steeply pitching beds. Coalbeds of the "fat" and "gas" group of medium rank emit more gas than low-rank and anthracite coal and Aachen and Saar coalbeds liberate more gas

than Ruhr coal of the highest emission. Approximately 320 cu ft/ton of clean coal production is the emission average from flat and moderately pitching "fat" and "gas" coalbeds of the Ruhr, Aachen, and Saar basins.

For instance, the daily attainable output of clean coal from an operation in a 5-ft-thick coalbed, with an open field of 13.5 ft, an air velocity of 400 ft/min, a gas emission of 320 cu ft/ton, a fluctuation factor of 1.5 and with a mandatory maximum gas concentration of 1 percent on a 5-day week operating basis would be limited to

$$\frac{6048 \cdot 1.5 \cdot 4 \cdot 2 \cdot 1 \cdot 1.1}{5 \cdot 1.5 \cdot 10} = 1,060 \text{ (short) tons,}$$

and to 1,590 tons if work in a gas concentration of 1.5 percent would be approved.

Drainage is mostly practiced in advancing and Z-mining systems but seldom in retreating longwalls. Figure 10 shows ventilation diagrams for advancing, retreating, and Z-type longwalls (6). The drainage holes for advancing longwalls are drilled from the gate roads behind the longwall face. For Z-systems, the drainage holes are also drilled behind the face from the gate road that is advanced with the face. Retreating longwall systems do not favor gas drainage. Holes that were drilled from gate roads ahead of the face may be cut off by the effect of mining when the face passes through. Drainage is feasible only if a portion of the gate road can be kept open behind the face and if holes can be drilled from there. Drainage holes are drilled in a pattern shown in figure 11 at an angle of approximately 50° into the roof and sometimes into the floor strata on 33- to 100-ft centers depending on the rate of face advance and the speed of drilling (31). Rotary rigs drill holes of 120 mm (4-3/4 inches) in diameter with roller bits. Percussion drills that fit into the hole are used in the Saar basin. The holes are 130 to 200 ft long and it takes approximately two shifts to complete a 170-ft hole. The drill cuttings are usually flushed out with water, but if the holes are drilled dry, special

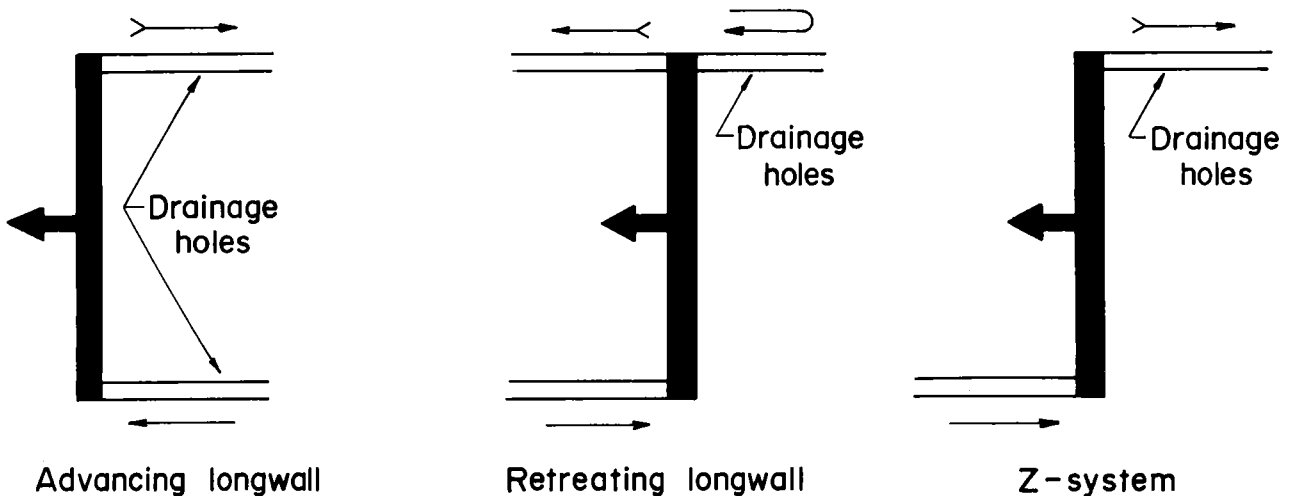

FIGURE 10. - Face ventilation diagram.

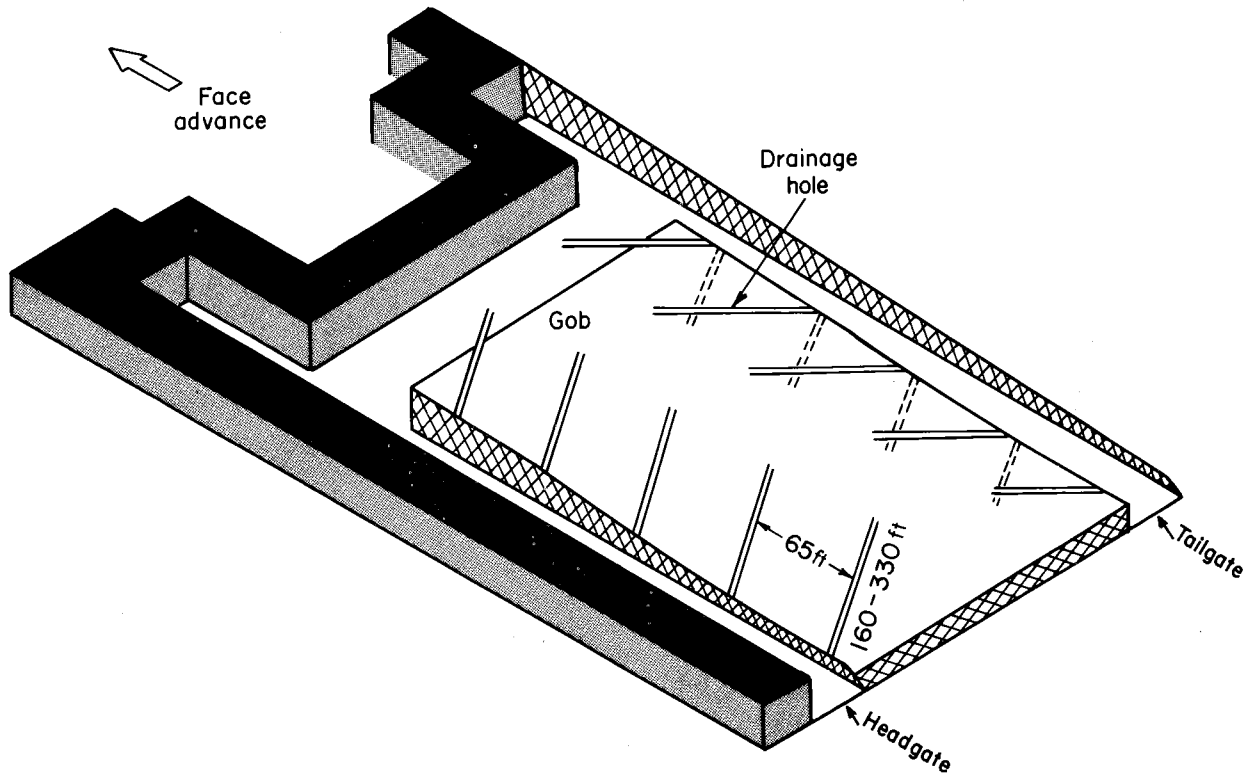

FIGURE 11. - Drainage holes placed from gate roads.

precautions must be taken on account of the ignition hazard. Recently such an ignition set off a fire that destroyed powered roof supports for an entire longwall face.

The holes are cased for 35 ft and the casings are fitted with rubber packers to provide a gastight seal. Water traps are installed at the foot of each borehole or at the lowest point of the system. They were developed by the Experimental Gallery DERNE to operate by compressed air or simply by gravity. Instrumentation to measure quantity of flow and CH_4 concentration is provided and the measurements are posted on a blackboard at the mouth of each drainage borehole. A flowmeter is used to determine flow quantity. Interferometers measure the gas concentration. They are calibrated to indicate up to 100 percent of CH_4 . Self-recording instruments are also used.

The gas-air mixture is conducted in large diameter pipelines to minimize friction. Pipelines in gate roads are at least 12 inches in diameter and main lines, some of which are 24 inches in diameter, carry the mixture to the surface where blowers generate a negative pressure of up to 140 inches water gage (WG). Some mines use shop built venturi tubes with a negative pressure of 70 inches WG. The lines are protected by flame barriers that consist of vessels with 4-mm (5/32-inch) glass spheres deposited in a 16-inch-thick layer. Flame barriers are also installed between the blower and the distribution net or the flare that burns off the gas. Each flame barrier must be equipped with fire quenching devices that can be initiated automatically. Two sets of

instruments, flow and concentration meters, are mandatory to provide redundancy for the surveillance of the mine gasline net. Calorimeters and thermostats are also installed. The temperature of the gas introduced to the blowers shall not exceed 176° F. Gas from the gob is drained through 6-inch pipes that are inserted into the bulkheads that seal these areas.

In 1970, 580 million m³ (20 billion cu ft) of CH₄ was drained from German coal mines and 55 percent of that amount was utilized as fuel. The balance was burnt off by flares.

DUST CONTROL

Dust is allayed by water, but the constraint, that fine coal under 3/8-inch size and containing more than 6 percent of water cannot be cleaned in the usual dry preparation systems of the Ruhr district, imposes a limit on the quantity of water added to the coal by infusion or sprays (1).

Water infused prior to mining most effectively pervades the coal and also improves its plowability. Water infusion is mandatory in Germany (17). Exemptions are approved if infusion is known to initiate such hazardous conditions as coal rolling out from the face, strata movement, and floor softening. Figure 12 is a diagram that shows the methods of water infusion. The diagram is self-explanatory. The deep and far infusion methods are new developments. The far infusion method involves daily drilling of one or two holes to the depth of the weekly face advance and then water is infused to saturation. Accordingly, the holes are placed in a staggered pattern and on centers selected to complete the infusion of a face within a week (fig. 13).

The long-front infusion from gate roads eliminates interference of infusion connected work with the face production. The method is applicable to retreating and Z-type longwalls. Infusion pressures are kept lower than with face infusion in order not to disturb the roof. The rate of infusion ranges from 0.5 to 2 gal/min. Infusion is continued also on weekends until water oozes from the face, usually when the hole is within 20 to 50 ft. Self-recording flowmeters monitor the water consumption. The daily rate of water induction is calculated as follows:

1 percent of moisture in the coal corresponds to 0.075 gal/cu ft of coal in situ,

daily advance (ft) × face length (ft) × coalbed thickness (ft)
 × 0.075 = daily quantity of water (gal) infused to provide
 1 percent of moisture,

$\frac{\text{daily water quantity (gal)}}{\text{pump output (gal/min)}} = \text{infusion time (min)},$

for instance,

$15 \times 700 \times 5 \times 0.075 = 3,900 \text{ gal.}$

If pump output is 15 gal/min, the infusion time is $3,900/15 = 260 \text{ min.}$

From the face	Near infusion		$l = b + 20 \text{ inches}$ (b daily advance) $a = (1.5 \text{ to } 2) \times l$
	Deep infusion		$l = 40 \text{ ft}$ $a = (1.5 \text{ to } 2) \times l$
	Far infusion		$l = 5 \times b$ $a = (1.5 \text{ to } 2) \times l$ boreholes are staggered and placed daily
From the gate roads	Long-front infusion		$l = 50 \text{ to } 265 \text{ ft}$ $a = 50 \text{ to } 200 \text{ ft}$
From mine openings outside the coalbed	Pre-far infusion		$l = \text{distance to coalbed}$

FIGURE 12. - Water infusion methods.

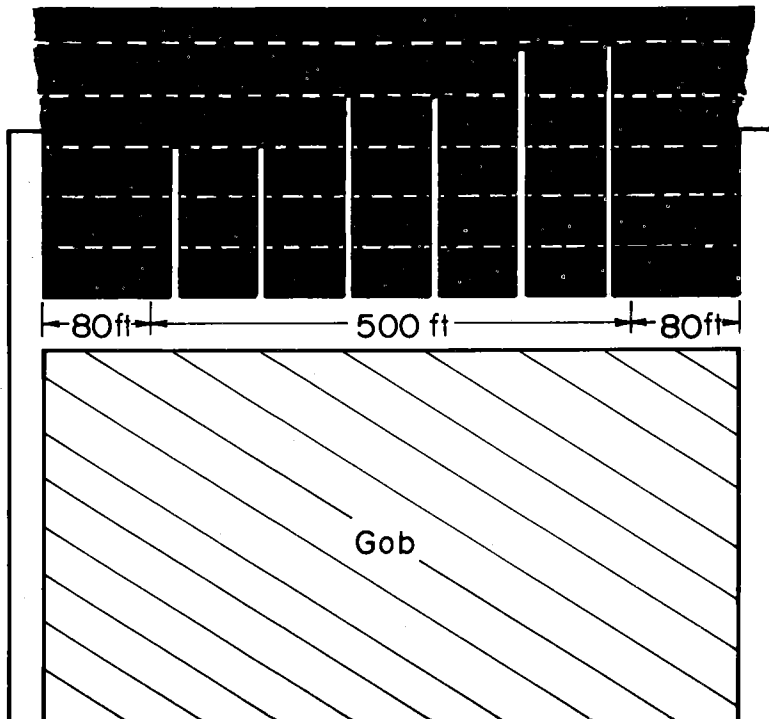

FIGURE 13. - Diagram of the far-infusion method.

Holes for near infusion are drilled with hand-held pneumatic coal drills. Light carriage drills have been developed for deep and far infusion. Pneumatic carriage-mounted drills of 5 to 6 hp, 2,600 lb of thrust, and 190 rpm serve to drill the holes from the gate roads for long-front infusion.

Augers are 1-3/4 inches in diameter and come in 5-ft joints. The drill bits are 2 and 1-25/32 inches. The drill cuttings are removed pneumatically.

Automatic hydraulic packers serve as probes for the infusion from the face. High pressure water flowing through an orifice inflates the probe and holds it securely in the hole. A 13-ft long safety hose is coupled between the infusion head and the control valve to keep the workman at a safe distance should he turn the valve and the probe should suddenly fly out of the hole (2).

Infusion pressures are 3,000 to 5,000 psi. Pneumatically driven pumps of the differential piston type with quantity regulation and 1- to 1.5-gal accumulators average an output of 10-15 gal/min. Electric pumps, often the same pumps that supply the hydraulic system of powered supports and the shifting rams, have come into use recently. Wetting agents are apportioned to the water at the pump in

many mines to overcome the water surface tension and thus reduce the water quantity. Salts such as calcium chloride are added to prevent quick evaporation of the moisture.

Where adverse conditions prohibit water infusion, sprays are placed along the face conveyor line to wet the plow track. The sprays can be operated manually, but automatic initiation by the passing plow is preferable because it properly apportions the quantity of water that is ejected under a pressure of 200 psi and may cause coal preparation problems if the flow is unrestricted.

Reducing the number of cutter bits, greater bit penetration, slower rotation, and greater traveling speed of the machine are favorable factors in dust control with drum shearers. Radially or tangentially acting sprays are arranged on the drum body of a shearer. Concern for the coal preparation limits the spray water quantity to 30 gal/min.

In caving longwalls, the rock falls pose a severe dust problem. The Center investigates sprays that are initiated by the shifting mechanism of the supports.

Another means of dust control is homotropical ventilation, that is, air and coal flowing in the same direction. It keeps the intake air cooler and the dust concentration lower compared with the conventional antitropical ventilation where high relative velocities between air and conveyors may initiate aerodynamic dust entrainment (27). Hoods, sprays, and the automatic load activated "Conflow" system are used at critical points such as coal breakers, transfer stations, and loading points. Dry cyclones up to 3,500 cfm find only a few applications. Calcium chloride pastes and powders are not effective in allaying respirable dust. The Research Center developed a wet dust collector with a capacity of 18,000 cfm. One prototype is in operation in the tailgate of a longwall face and is suspended from a monorail for easy moves.

ROAD REINFORCEMENT BY ROADSIDE PACKS

Road packs made from hydraulic material have been introduced recently in an effort to prevent ventilation air leakage and to substitute mechanized road reinforcement for manually set cribbing now commonly used along the longwall edges. The mechanically placed road reinforcement can keep pace with the ever faster moving high-production faces. The following hydraulic materials are suitable for building road packs:

1. Natural anhydrite.
2. Synthetic anhydrite.
3. Blitzdammer (a quick-setting cement-lime mixture).

Natural anhydrite is preferred because it can be transported pneumatically and is mixed with water and an activator just before being placed. The anhydrite blowing machine is a modification of a pneumatic stowage machine. It is capable of sending a continuous stream of dry anhydrite through a 4-inch

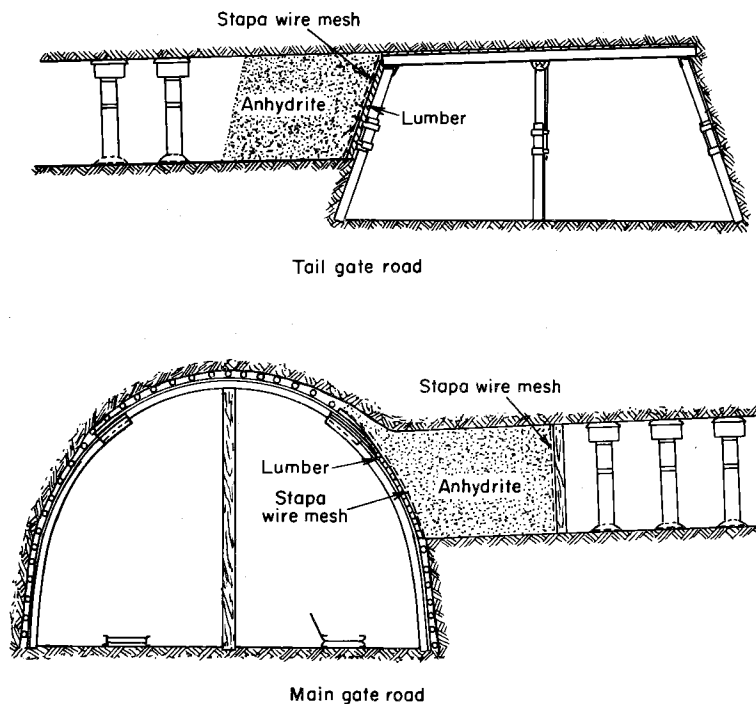

FIGURE 14. - Anhydrite roadside packs.

lagging of the roof support and are nailed to breaker posts at the gob side. Natural anhydrite attains a compressive strength of 2,000 to 3,000 psi after a few days. Modification of the blow nozzle and improvement of the blowing process by swinging the nozzle to cover the space helped to equalize and increase the strength of the pack.

The synthetic anhydrite is much finer than the natural anhydrite and, therefore, is supplied in bags to an underground pump and mixing station where the slurry is prepared and the activator is added. The water ratio is 0.40 to 0.45. One pump station can handle 4 to 5 tons of anhydrite per hour over a distance of only 800 ft. The forms must be substantially built to hold the slurry.

Blitzdammer is also a quick-setting material. But an activator is not needed. The slurry is prepared with a water ratio of 0.36 to 0.45 and can be pumped over a distance of 1,500 ft at a rate of 4 to 5 tons per hour. Compared with wood cribbing, anhydrite or Blitzdammer packs are early bearing (7). Experience with road packs indicated that the adjacent rock strata must not be weaker than the anhydrite. The rock strength should exceed 4,000 psi so that the reinforced road remains stable; otherwise the ground will deteriorate under pressure. In soft ground, the Saar mines prefer to place Saaralite, a local product, that attains a strength of only 700 to 1,000 psi.

pipeline over a maximum distance of 3,300 ft at a rate of 6 tons per hour (fig. 14). Mixtures with 9 percent of makeup water and 1 percent of activator achieve the best results. Water and activator are mixed in a tank. The solution is pumped under pressure of 200 psi through a 1-inch line to the use location where it is added to the stream of dry anhydrite through a ring nozzle.

When anhydrite is blown, it reposes at an angle of 20° to 30° to the vertical and requires only a light framework of wire mesh and Stapa wire, a wire mesh with paper backing, to retain the mixture in place. Stapa mats are laid upon the

ROOF SUPPORT AND ROCK MECHANICS RESEARCH

The largest organization for research and development in the German coal mining industry is Bergbau Forschung GmbH (Mining Research Company) of the Steinkohlenbergbauverein, the German Coal Mine Operators Association at Essen-Kray. The research work is by tradition operation oriented. The chief goal is to double the present output of 4.5 tons/man-shift. The spectrum of research comprises coal mine environment and safety, mining technology, and utilization.

The Research Center for Roof Support and Rock Mechanics is part of the coal mine safety research program. The title describes the activity. Ground control at longwall faces and gate roads is the main program and statistical treatment of collected key data is the approach. The Center stores industry-wide information in a face and roadway data bank and disseminates it to the mines. Another approach is the study of mine models on two test stands, one for longwall face models and the other for gate road models.

The strata are explored by core drilling, and physical properties of rock samples are investigated by the petrographic laboratories of mining research.

Under sponsorship of the European Community, the Center in cooperation with the Aachen Technical University is developing a three-dimensional mathematical model of ground stress distribution around mine excavations. The project has not yet reached maturity (5).

The program of testing powered supports fulfills a vital need of the industry. Entire support units can be investigated in a large test frame. The Center employs approximately 90 persons and is headed by Dr. Oskar Jacobi.

Other groups within the Steinkohlenbergbauverein's mining research organization apply more deterministic methods to ground control research rather than the Roof Support and Rock Mechanics Research Center's statistical approach. The design of a strain bolt that indicates ground stresses at certain predetermined distances from the mouth of the borehole is an effort in this direction. Obviously ground stresses could be measured at critical mine locations that are instrumented by strain bolts and the information could be transmitted to surface control centers where it can be monitored to warn of imminent roof failures (25-26).

Another approach are precision measurements in gate roads. The long-range program includes determination of geological and mine technological parameters such as in-situ stress. The objective of the study is to quantify the parameters so that cross section and support conditions can be predicted and the gate road support can be optimized.

THE LONGWALL SURVEILLANCE METHOD

Roof support problems are severe at many German longwall faces and can be grouped as follows:

1. Cavities in front of the support.
2. Roof steps and cleavages.
3. Cavities above the supports.
4. Rock rolling in between the supports.

Faults and water influx weaken the roof. Other causes that may adversely affect ground stability are abutment pressure from adjacent mining, the punching effect of riblines from residual pillars in overlying or underlying coalbeds, the thinning out of shale under massive sandstone or a large rock parting in a coalbed. Alinement of the face with the direction of the main cleats is also known to have a detrimental effect on roof strength. Cavities at the face as the result of failing roof strata slow the advance of the roof support. The voids above the canopies must be cribbed; but the reduced support strength causes further roof deterioration in a vicious cycle.

Short spans from canopy tip to face, little delay in supporting the roof, adequate support capacity, and effective gob deflectors or flushing shields often succeed in improving roof control. Straightening sloping coal faces in thick coalbeds by gluing wood bolts into the coal is also helpful in reducing the critical span from canopy tip to face. The "walking effect" of advancing units, when canopies are dropped and set again, induces cavities above the support and can even shift the caving line from the gob field onto the canopies so that the debris will bury the rear legs. Wire mesh, stretched over the canopies, may prevent the failure of such a roof.

The Essen Center's longwall face surveillance method provides quantified evaluations of roof support problems and offers an assist in their solution. The method is designed so that the most important key data can be collected with little effort. The study man is a supervisor or a miner trained in operations study whose normal task is to establish performance rates of piece work in German mines. He marks the data on a blank and needs about 3 hours for roof and support surveillance at a longwall face. He can handle five faces if each face is surveyed once a week. The frequency of surveys depends on the condition of the support and the roof. German miners consider a longwall face as average when 25 percent of the roof area observed at sample survey strips (fig. 15) is taken up by cavities of a mean height of 1 ft.

Subject of the survey is as follows:

1. The condition of the support (pressure in the legs, position of legs, defects, difficulties in advancing the units, distance to the coal face).
2. The roof conditions (roof and floor strata, cavities, roof steps, location of the caving line).

The surveys are conducted by taking samples systematically. From the entire face only 20 to 25 strips, 3.3 ft in width are observed (8; fig. 15).

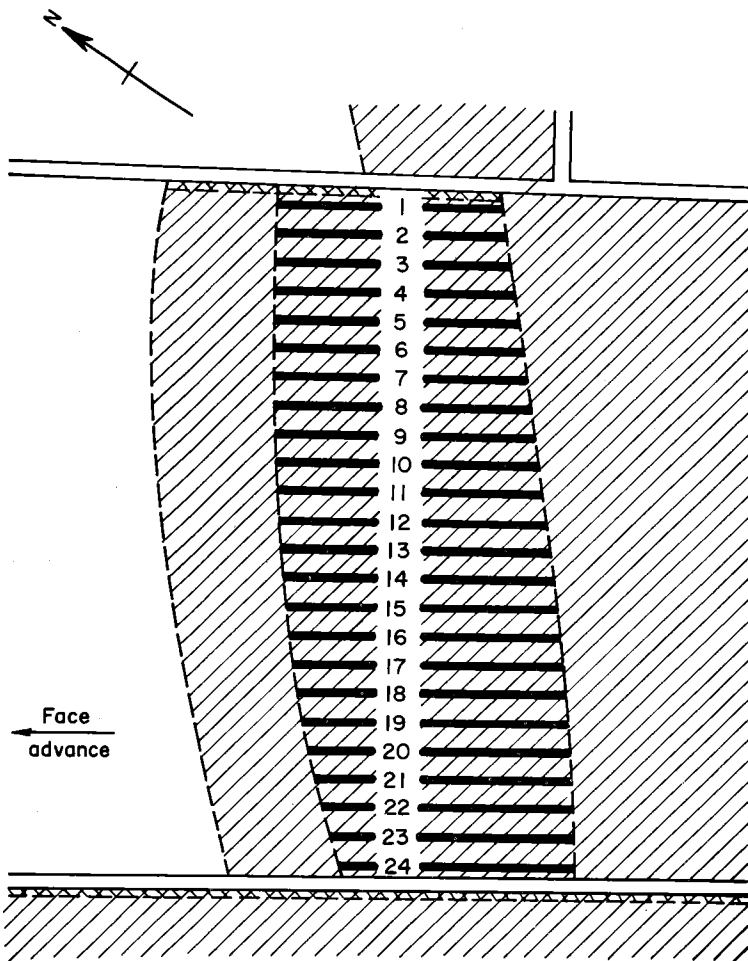

FIGURE 15. - Face survey map.

Unit No.	Date					Mine								Coalbed				Section						
	Leg pressure					Difficult advance								Defects										
	Piston gage reading	Legs too short	Legs defect	Hoses defect	Valve block defect	Hood on the canopies	Difficult advance	Legs gone solid	Mechanical defect	Low pressure	Uneven floor	Unit not aligned	Legs retract slow	Debris foul front track	Debris foul unit	Canopies	Leaf springs	Alignment guides	Bases	Steering rams	Floor shift rams	Top shift rams	Legs not normal to strata	Flushing shields
1	8																							
2	10															X								
3	7	X																						
4	//						X					X	X											
5	-		X																					
6	-																							
7	-						X							X									X	
8	-																X							
9	-		X				X			X														
10	-																							

FIGURE 16. - Roof support survey blank.

A. The Support Survey

The support is best surveyed at the sample stations in conjunction with the roof survey. Should, however, the condition of the supports be questionable, every support unit at the face must then be included in a survey that will take a full man-shift at least. A line in the blank is assigned to each unit (fig. 16). The unit number is listed in the first column. The blank is a "check list" that questions the unit about each possible deficiency and is divided in three groups:

1. Interior prop pressures by piston-gage readings and the reason for low pressure such as defective hoses.
2. Information why advances were slowed or halted, such as a unit covered with rock.
3. Defects such as damage to canopies.

After the data are processed, the three groups appear again on the printout that presents information on the deficiencies and the frequencies of occurrence and so determines the weak points of a roof support.

An increase in the frequency of defects in terms of time points to technological shortcomings as well as to poor maintenance.

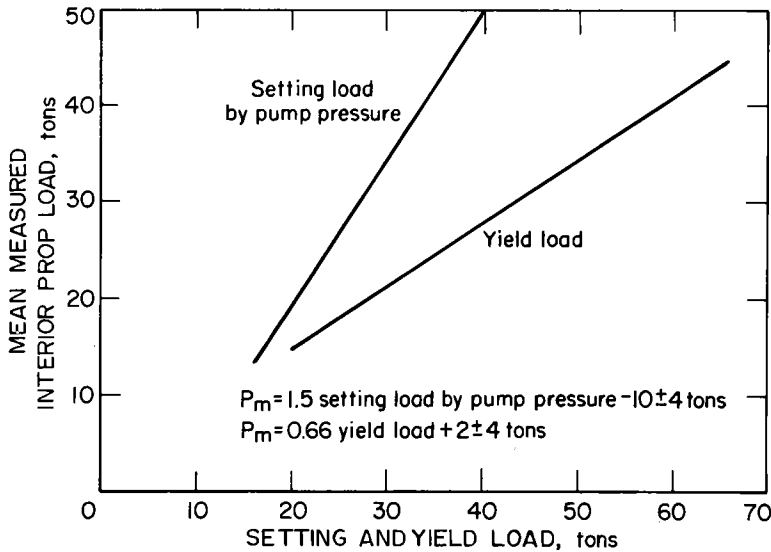

FIGURE 17. - Prop loads in terms of setting and yield load.

If defects accumulate suddenly, any or a combination of the following conditions may be at fault: Poor roof control, tectonic disturbances, contamination of hydraulic fluid, and inadequate strength of components (appendix, face 15).

Random measurements of interior prop pressures (hydraulic) are taken when indications point to insufficient support strength or to deficiencies of the hydraulic system. The pressures are measured with self-recording gages that chart the pressure over a 24-hour period.

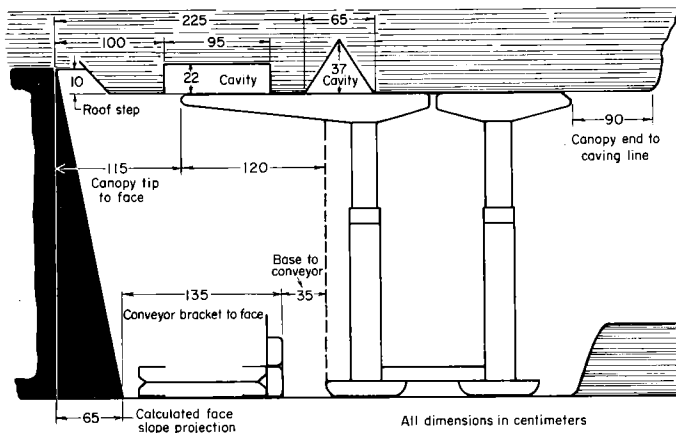

FIGURE 18. - Face survey diagram.

Results from the evaluation of interior prop-pressure measurements (fig. 17) revealed that an increment of 10 tons in the setting load corresponded to a raise of 15 tons in the prop load. The plot for the yield load was much flatter. An increment of 10 tons in yield load raised the prop load by only 7 tons. Hence, the setting load affected the prop load twice as much as the rated load to yield of props did. If it is necessary to strengthen the

support capacity at a face, it will be easier and more effective to boost the setting load than to introduce props with higher yield rating.

B. The Roof Survey

The diagram indicates where the measurements are taken (fig. 18). The critical span from canopy tip to face is measured at the more advanced canopy of a double frame. Other measurements are base plate front to conveyor, indicative for the delay in supporting the roof; conveyor bracket to coal face, indicative for the effectiveness of the shifting rams; the position of the caving line; number and height of roof steps and cavities; number and type of

cleavages that outline steps and cavities and whether they run normal to the strata or are sloping to or away from the face.

The immediate roof and floor are described by type of rock, compressive strength and numbers, and location of distinct bedding and slip planes. This is done only once for each face unless the strata change. Then a new strata description is needed (fig. 19).

The data collected by the study men are evaluated by automatic data processing (ADP). The roof evaluation comprises data from 10 survey days equal to 200 to 250 observations. The ADP printout tabulates the data for comparison with key data and criteria listed in table 2. This table is the result of

120 of such face investigations and contains means with standard deviations as well as criteria to rate the observed data as "good" or "bad." Remedial measures are suggested in the last column of the sheet. These are the critical items listed on the table:

1. Mean area of cavities in percent of the roof area observed at the survey strips (fig. 15).

If the area exceeds 30 percent of the observed roof area, the possible causes should be investigated. If conditions in a longwall vary sharply, for instance, more cavities occur in one portion of the face than in the other, then residual pillars and riblines over, under, and next to the longwall face may be the cause.

2. Mean width of cavities.

Wide cavities reveal inadequate support (see No. 6). Even small cavities should not be neglected, because they tend to increase in height and width.

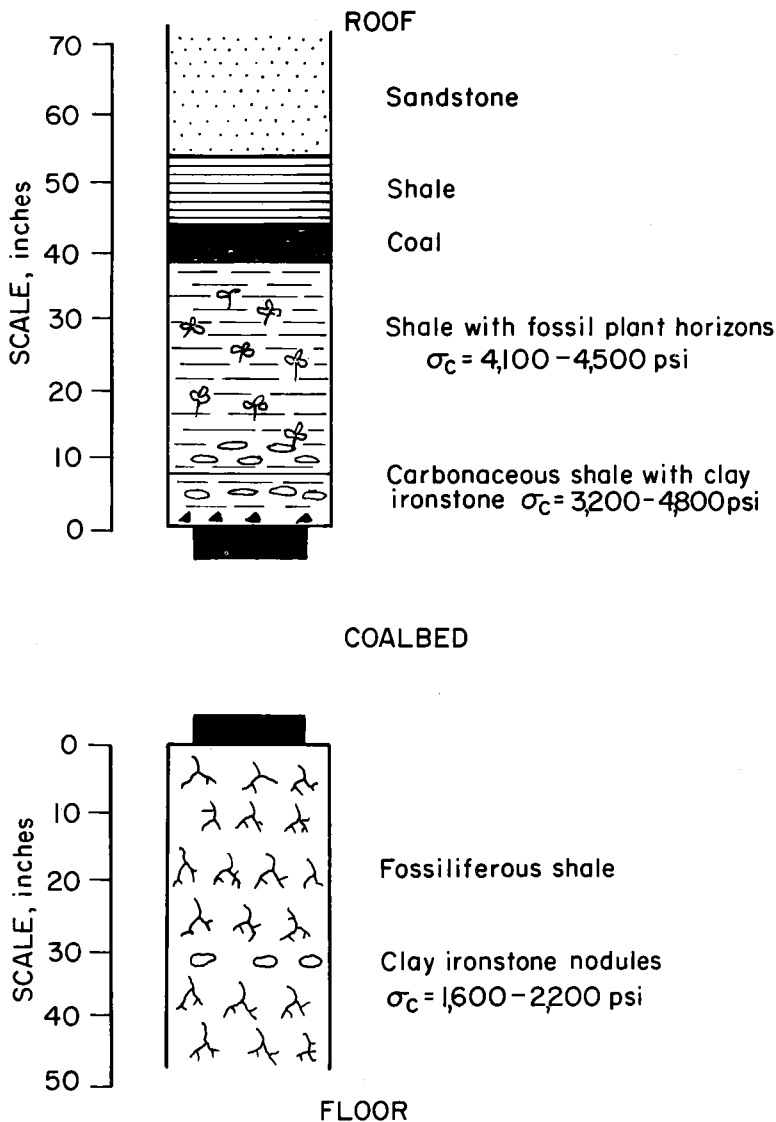

FIGURE 19. - Columnar section of strata above and below a coalbed with rock strength.

3. Mean height of cavities.

If the cavities average less than 6 inches in height, the "harmful" influence of the cavities area (see No. 1) can be assumed to count only as one-half, for instance, 15 percent instead of an observed 30 percent. That means the range of effective use of powered supports is extended. Should the mean height exceed 16 inches, the support capacity should be examined and boosted, if necessary.

4. Sensitivity to caving E in percent.

The Center formulated this term to designate the area of cavities between canopy tips and face in percent of the observed roof area, if the span from canopy tip to face is 40 inches. It is a criterion that expresses the effect of parameters such as rock strength, stratification, cleavages, and jointing system in relation to the face layout and serves to compare various longwalls and coalbeds. The effectiveness of powered support is questionable, if the sensitivity to caving exceeds 30 percent.

5. Mean area of cavities in front of the support in percent of the observed roof area.

If this area exceeds 30 percent of the observed area, the span from canopy tip to face and the delay in supporting the roof after exposure must be shortened.

6. Frequency of distances from cavity to face within 8 inches of the face in percent of all the cavities in front of the support.

The roof can be held easily, if less than 50 percent of the cavities in front of the support appear within 8 inches from the face. The roof tends to fail if this frequency exceeds 80 percent combined with a mean area of cavities in front of the support of more than 30 percent. Sometimes the roof may then be stabilized by cement injection or installation of resin anchored roof bolts.

7. Maximum area of cavities F_{max} above the support in percent of the observed roof area.

The roof above the supports often deteriorates while the canopies are dropped and then reset. German miners call this the "walking effect." If the maximum area F_{max} is greater than the sensitivity to caving E , either planks or wire mesh, the mats firmly tied together, may catch the rock and prevent a roof fall. Figure 20 shows a plot referring to a coalbed, where $F_{max} = 32$ percent is slightly greater than $E = 30.6$ percent.

8 and 9. Number of roof steps on a 330-ft-long strip (= 25 survey stations each averaging 13 ft of roof span) and mean height of steps.

These data may indicate whether the support capacity is adequate or not.

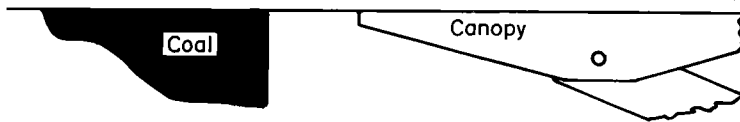
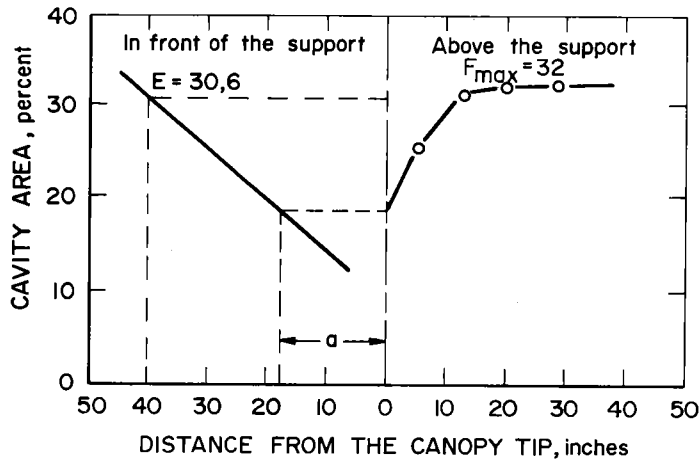

FIGURE 20. - Cavity area in front and above the support.

10. Mean length of roof cantilever beyond the canopy gob end.

If this rock cantilever is less than 40 inches in length, effective flushing shields are a necessity.

11. Length of face that sloped more than 16 inches (40 centimeters) in percent of the total face length (fig. 18).

The slope projection increases the critical span canopy tip-face. The coal face may be stabilized by installing resin anchored wood bolts straight ahead at midseam height. Cutting with backward tilted drums will also correct or even prevent the sloping at shearer faces.

12. Mean span canopy tip to face.

This critical span affects the roof more than any other parameter.

13. Mean distance front of foot plate to conveyor.

This span is a measure of the delay in supporting the exposed roof. It should not be much wider than one-half of the support advance step because the probability of finding units close to the conveyor equals that of finding units that have not made their move yet. Timely advance of the support unit minimizes the critical span from canopy tip to face.

14. Mean distance conveyor bracket to face.

Effectiveness of conveyor shifting rams is questioned.

TABLE 2. - Key data and criteria for roof investigations

No.	Criteria	Mean and standard deviation	Good	Bad	Recommended action
1	Mean area of cavities....percent..	18±16	<15	>30	Determine causes.
2	Mean width of cavities....inches..	51±22	NAP	>72	Hold rock if No. 6 is "Good."
3	Mean height of cavities.....do....	12± 5	<6 1/2 E and F	>16	Support capacity too low?
4	Sensitivity to caving.....percent..	E = 24±15	<15	>30	Powered supports questionable.
5	Mean area of cavities in ...do.... front of the supports.	F = 14±14	<10	>30	Reduce span canopy tip to face.
6	Frequency of distances ...do.... cavity to face within 8 inches of face.	NAP	<50	>80	Insert wood resin bolts into draw rock or stabilize roof if F = 30 percent.
7	Maximum area of cavities ...do.... above the supports.	23±18	F<E	F>E	Wire mesh.
8	Number of roof steps on a 330-ft-long strip.	4± 4	<10	>10	Raise support capacity.
9	Mean height of roof steps..inches..	4± 2	<4	>6	Do.
10	Mean length of roof over- ..do.... hang beyond canopy gob end.	45±24	>40	<40	Flushing shields or gob deflectors.
11	Length of face that percent.. slopes more than 16 inches.	25 percent in 6.5 ft coal, 35 percent in 8.5 ft coal	<10	NAP	Use wood resin bolts if F > 30 percent.
12	Mean span canopy tips-- inches.. face.	24± 8	<24	NAP	See No. 5.
13	Mean span front of foot ..do.... plate--conveyor.	21± 8	1/2 step	NAP	If greater, reduce delay in supporting the roof.
14	Mean span conveyor ..do.... bracket--face.	48± 8	Conveyor width and plow track	NAP	If greater, check conveyor push rams

NAP Not applicable.

Source: (5), p. 19.

The success of the recommended measure is often indicated by an improvement of several criteria. For instance, an improvement of the protection against flushing not only speeds the advance of the supports unimpeded by debris, but also reduces the tendency of the roof to cave, because the roof strata find support by the bed of the caved rock lying on the canopies and are kept wedged in their natural position. It is the combination of several criteria that affects roof control in each coalbed. Accordingly, the evaluation must give answer to the following questions:

1. Is a shortening of the span from canopy tip to face promising?

Productivity may be improved, if this critical span can be kept to a minimum.

2. Which measures are effective in shortening the span from canopy tip to face?

This can be achieved by keeping distances from foot plate front to conveyor and from conveyor bracket to face as well as face sloping to a minimum.

3. Are poor roof conditions a consequence of insufficient support capacity?

The roof step count offers some clue to the adequacy of support capacity.

4. Will dropping the canopies during the support advance cause deterioration of the roof?

Advancing the support with canopies that keep contact with the roof or even exert a slight pressure against it is a practice advocated by the Essen Research Center which also suggest the use of forepoling cantilever bars. The research determined that the height of 87 percent of measured roof cavities was less than 16 inches. The weight of a rock stratum of such a thickness can be supported by a force of 0.1 ton/sq ft. Therefore, if such a force can be brought to bear against the roof at the face directly after exposure, the roof may be kept intact most of the time.

5. Could mine projection account for poor roof control?

The projection of panels should take account of tectonic disturbances, the jointing system, and riblines from adjacent mined panels and from residual pillars in overlying or underlying coalbeds.

THE GATE ROAD SURVEILLANCE METHOD

The loss of cross sectional area by roof sag, floor heave and rib move, and the deformation of roof support indicate the severity of the support problems in numerous gate roads. Many mines must make extensive and costly efforts in keeping the roads open. The Essen Research Center's gate road surveillance method is designed to quantify the evaluation of these problems. But while the statistical survey at longwall faces has proved its value for

9 years and was adopted internationally, the gate road surveillance is a relatively recent development. Therefore, the Center has not yet collected enough information to establish criteria (5).

The survey is conducted by systematic sampling. Cross sections at fixed intervals at say 70 feet are designated to be surveyed once or several times during the life of the road (14, 29). A blank with general data is filled for

All dimensions in centimeters

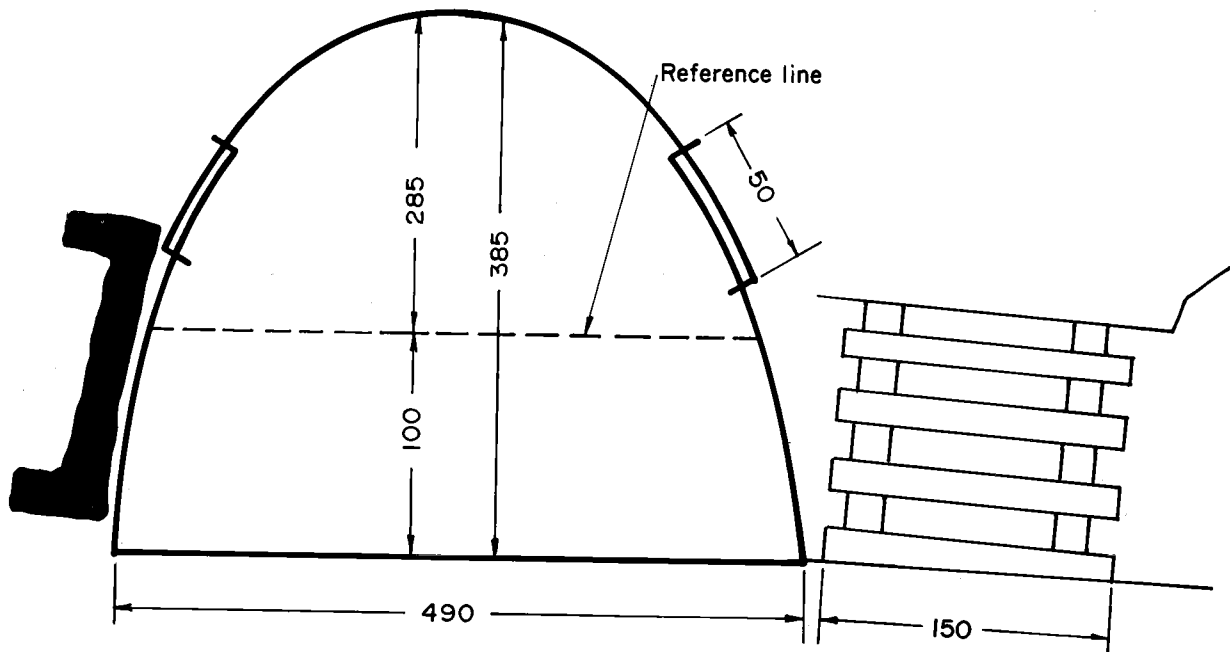

FIGURE 21. - General road data.

All dimensions in centimeters

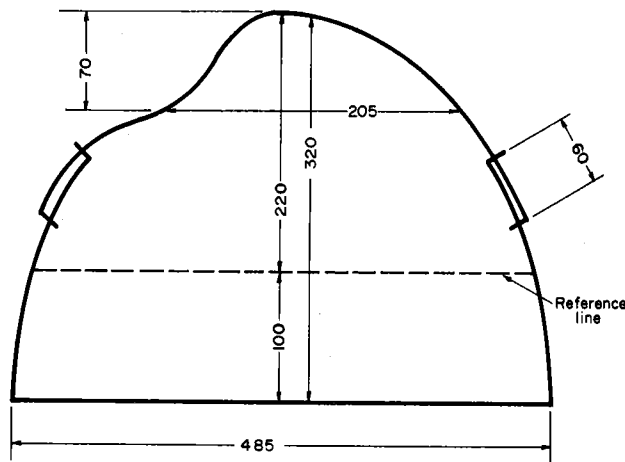
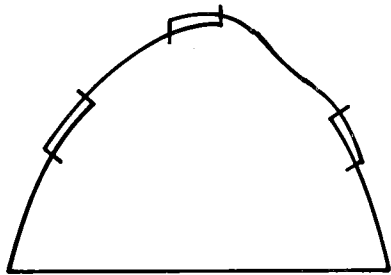
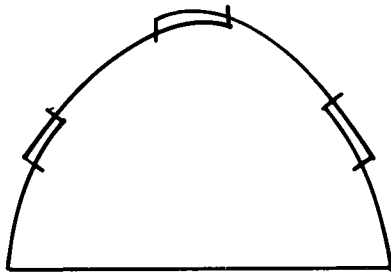
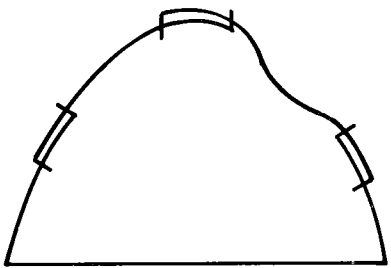

FIGURE 22. - Road survey sketch.



2



3

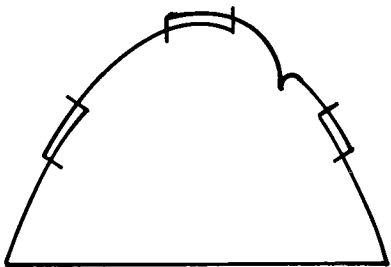

4

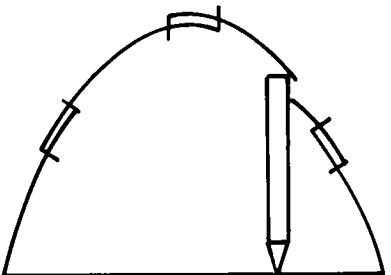

5

each road once (fig. 21). An approximate horizontal reference line is established to determine how much roof sag and floor heave contribute to the convergence. Each rib is marked at a certain distance down from the top ends of the rib posts or segments and these marks are connected by an elastic string. Distances to roof and floor are measured from this line. The immediate roof and floor strata are described by type, strength, and bedding or slip planes (fig. 19).

A blank is filled in for each survey and station (fig. 22). The inside dimensions, the location of a deformation, the overlap of support segments, modifications, and whether bottom is taken and how deep, are indicated. The condition of the support is rated from 1 to 5. The diagram explains the ratings and shows progressive stages of deformation (fig. 23).

The collected data are evaluated by ADP. Figure 24 is a plot from a printout that shows roof sag, floor heave, and depth of bottom taken. The data are means of measurements ahead and behind the longwall face. The location of the survey stations in terms of distances from the origin of the road are listed in the second column. The position of the face between stations is indicated. The data are identified by the following symbols:

° = Floor heave,

A = Roof sag,

S = Depth of bottom taken,

and are printed out between the 0- and 100-percent lines. Each symbol presents 2 percent of the original height. The plot shows how adverse conditions are closing a tailgate road that was driven adjacent to a mined-out panel.

FIGURE 23. - Road deformation ratings.

I NO. STATION	I LOCATION STATION METERS	I ROAD HEIGHT					I FLOOR WIDTH, PERCENT	I RATED SUPPORT DEFORMATION		
		I FLOOR HEAVE & BOTTOM DEPTH TAKEN								
		I PERCENT OF ORIGINAL HEIGHT								
		20	40	60	80	100				
I 1	I 20	I SSSSS					I AI	I 94.95	I 1.00	
I 2	I 40	I SSSSSSS					I AAAAAI	I 87.58	I 1.00	
I 3	I 60	I SSSSSSSSSSSSS					I AAAAAI	I 76.42	I 1.00	
I 4	I 80	I					I AAAI	I 73.89	I 1.00	
I 5	I 100	I SSSSSSSSSSSSS					I AA I	I 66.53	I 1.00	
I 6	I 120	I SSSSSSSSSSSSS					I AAAI	I 66.74	I 1.33	
I 7	I 140	I SSSSSSSSSSSSS					I AAAI	I 77.47	I 2.00	
*****I*****		I LONGWALL FACE						I -	I -	I -
I 8	I 160	I SSSSSSSSSSSSS					I AAAAAAI	I 75.37	I 1.00	
I 9	I 180	I SSSSSSSSSSSSS					I AAAAAAI	I 71.16	I 1.00	
I 10	I 200	I SSSSSSSSSSSSS					I AAAAAAI	I 64.42	I 1.33	
I 11	I 220	I SSSSSSSSSSSSS					I AAAAAAI	I 67.79	I 2.00	
I 12	I 240	I SSSSSSSSSSSSS					I AAAAAAI	I 67.16	I 1.67	
I 13	I 260	I SSSSSSSSSSSSS					I AAAAAI	I 65.26	I 1.67	
I 14	I 280	I SSSSSSSSSSSSS					I AA I	I 63.16	I 1.67	
I 15	I 300	I SSSSSSSSSSSSS					I	I 64.84	I 1.33	
I 16	I 320	I SSSSSSSSSSSSS					I AI	I 64.21	I 2.00	
I 17	I 340	I SSSSSSSSSSSSS					I AAAAAI	I 76.84	I 1.00	
I 18	I 360	I SSSSSSSSSSSSS					I	I 58.95	I 1.67	

FIGURE 24. - Printout of a tailgate road survey.

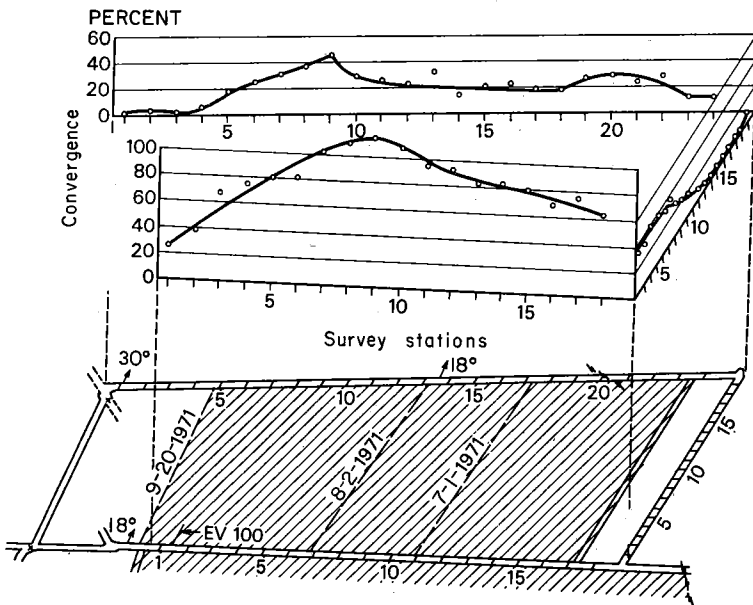

FIGURE 25. - Convergence plot.

Loss of floor width in percent of the original dimension and rated deformation of the supports at the survey stations are also listed.

The results of a complete survey are charted in figure 25 which shows how gate roads are affected by adjacent mining. After the first face passed through, convergences of 20 to 40 percent were measured in one gate road (29). The convergence was 115 percent in the other road after mining on both sides. In the same coalbed, a bottom road that was separated from the gob by a 100-ft-wide pillar

showed only 5 percent convergence next to the virgin coal. But the convergence reached 35 percent adjacent to the mined-out panel.

LABORATORY TESTING OF POWERED ROOF SUPPORTS

The objective of testing supports at the Essen Research Center is to find the flaws in design so that the manufacturers may know where to direct efforts for improvement. Newly developed support elements such as props and valves are tested in special rigs. The whole assembly is subjected to a battery of tests in the test frame. Only if all the requirements are met, the units are installed in mines for underground tests. The Essen facilities also serve to investigate units of elements of support that failed in service in order to find the causes of breakdowns (figs. 26 and 27).

The test frame where whole support units are tested consists of six pairs of platens that are arranged side by side. They are 26 ft long and have a

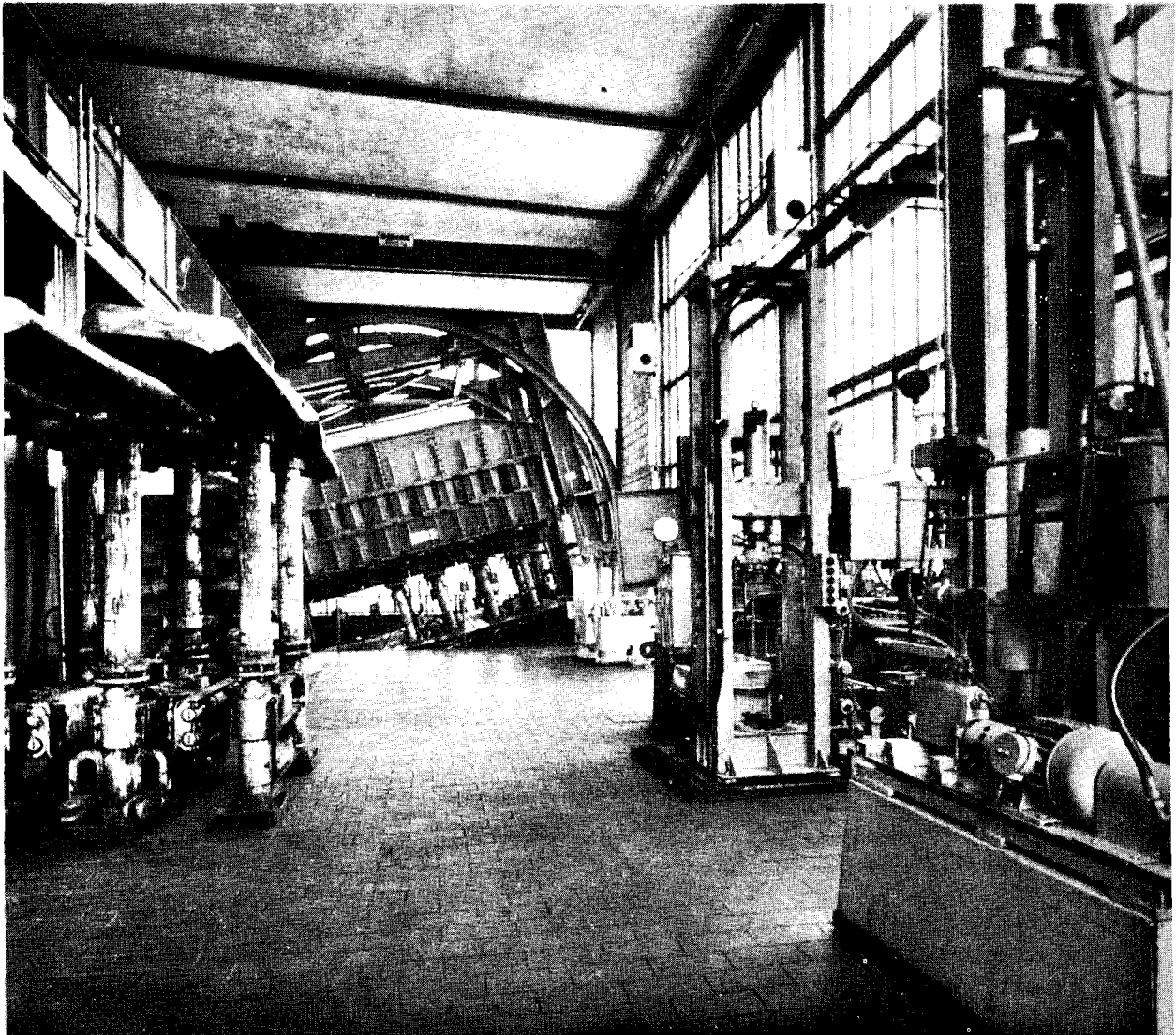

FIGURE 26. - Test frame for powered supports.

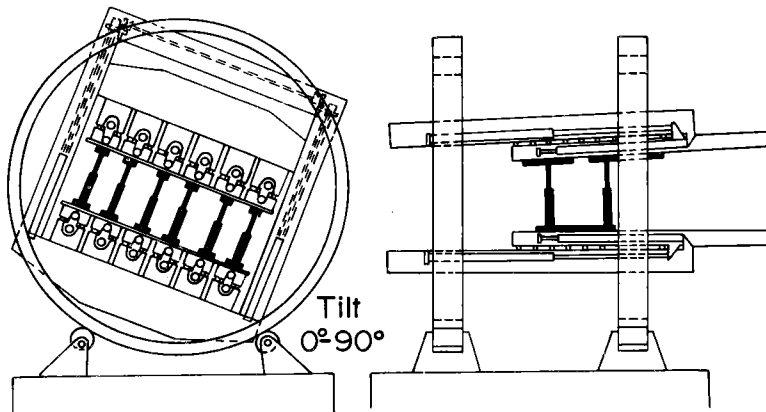

FIGURE 27. - Functional outline of test frame.

total width of 18 ft. Each platen is 3 ft wide. The top platens are inclined by 10 percent. The floor platens are even with the floor of the building. Movement of the platens in opposite direction subjects support units to convergence and horizontal thrust. Uneven ground is simulated by welding steel boxes to top and floor platens. Tilting of the frame simulates the pitch of coalbeds (24).

Tests of the whole assembled unit involve the following:

1. Base connections.
2. Canopy connections.
3. Ram shifting force.
4. Strength of structure to sustain strata parallel thrust.
5. Behavior in steeply pitching strata.
6. Advancing the support while maintaining pressure against the roof.
7. Advance on a layer of slack coal.

Figure 28 shows a synopsis of support testing.

Props, prop bases, and canopies are tested first. Strain gages are attached at critical locations to measure the surface tensions and to warn of critical loads. Prop bases and canopies undergo bending tests under increasing prop loads until the rated prop load is reached. The interior friction of the props is also determined.

Stability tests of floor and top connections include climbing upward and downward floor and roof steps in the x- and y-direction (fig. 29). The ram shifting forces that are transmitted to the prop bases and the canopy tips are measured by loadcells.

Breakdown tests are performed to investigate equipment reliability through many thousand operation cycles. For this test relative platen movement can be programed for automatic load cycling.







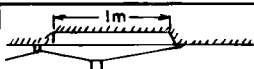
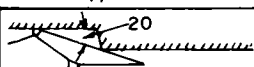
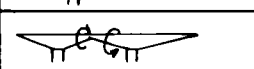

Uneven roof			Overcoming of 40'' wide cavities strength of canopy loaded at the rated prop load
			Deflection of the canopy in all directions by not more than 18° without being blocked by the prop and transmitting a bending moment to it
			Strength of canopy joint to resist moments and forces
			Overcoming 10'' high steps and then loading the prop with the rated load
Uneven floor			Overcoming 4'' high rectangular floor steps
	Pitching coalbeds		Deviation of props from the position normal to strata not exceeding 4.5°
			Angular deviation from the straight line of advance by 2°
			Shifting parallel to the direction of advance not more than 1'' per 50''
High coal			Substantial shielding against flushing, advancing supports unimpeded by the caved rock
Strata parallel movements: roof against floor			Accepting a roof thrust up to 1'' per 10'' of coalbed thickness and 10'' of advance
Sensitive roof			Advancing supports and maintaining 0.1-ton /sq ft pressure against the roof
			Automatisation of support operation
	High coal		Not more than 8'' distance between canopy tips and face
	Support field fouled		Support must advance even if partly covered by rock
General requirements			Adequate valve and hose installation
			Interchangeable fast-wearing elements to be easily taken apart for transportation

FIGURE 28. - Synopsis of support testing.

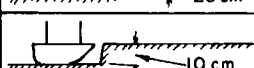
PROGRAMS RELATED TO POWERED ROOF SUPPORTS

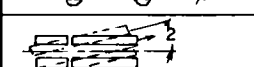
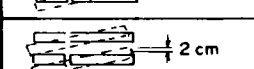
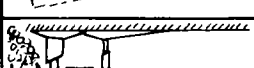
The Essen Center developed programs for preventive maintenance, operations studies, and investigation of hydraulic supply.

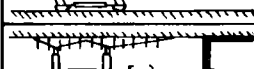
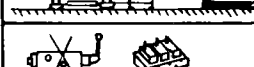
Preventive maintenance of powered supports

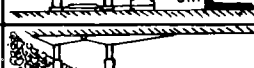
Immediate repair of supports and functional tests to preserve a safe support capacity are of utmost importance. The goals are as follows:

1. To secure full information on each repair.

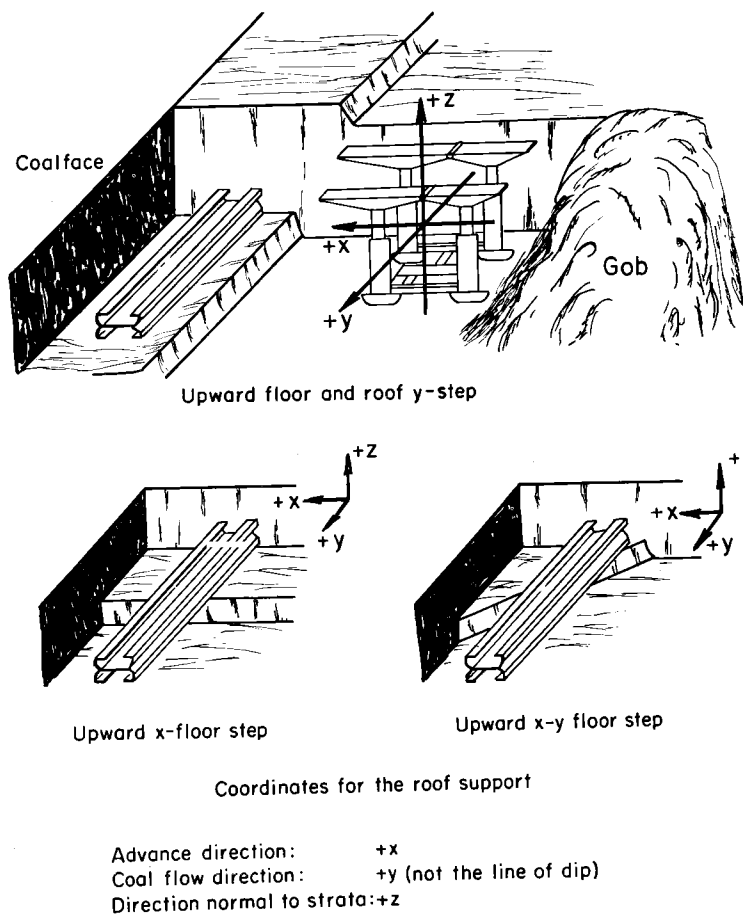

FIGURE 29. - Step types.

5. Periodic functional tests.
6. Cost accounting.

The heart of the maintenance organization is the control center where all reports are collected and all directions are issued (18).

Operations studies

Time studies may extend over 6 to 10 shifts to obtain a large sample of data such as the following:

1. Delays in supporting the roof.
2. The number of support advances in terms of time elapsed.
3. The effect of adverse conditions.

2. To direct maintenance men to the highest efficiency in the performance of their duties.

3. To check support capacity by periodic function tests.

4. To determine the weak points of the system.

5. To obtain an accurate breakdown of all costs.

The following is an outline recommended by the Essen Research Center to meet the indicated objectives:

1. Inventory control by index cards.
2. Daily visual inspection and functional tests by the face crew.
3. Direction of repairmen effort and parts use.
4. Weekly inspection by supervisor.

Blanks were designed to collect and arrange time study data that are then processed by computer. The stochastic distribution of face activities is obtained from such studies. The Center developed a simulation model to determine the optimum face crew size and a minimum delay in supporting the roof. Occasional local difficulties are also taken into account.

Hydraulic supply

The support of a face with 2,200 tons per day of production needs 4,000 to 6,500 gal of pressurized fluid. This amounts to 3.5 to 6 gal/min during an 18-hour working day. Sometimes the supply of fluid is inadequate at the face due to supply lines of too small a diameter and unsuitable arrangements (15). Undersized systems cause such high pressure losses that regular function of the support units becomes questionable. Therefore, the Center initiated studies with a view of designing systems of ample capacity. Instrumentation of supply nets and statistical analysis of the collected data made it possible to evaluate and then to improve existing systems. The planning of supply nets requires data such as pressure loss in lines, magnitude of operating pressure, quantities and rate of flow and time overlap of simultaneous shifting operations. On the basis of these data the supply net can then be correctly dimensioned by applying simulation techniques.

The following parameters must be determined to select the pump capacity:

1. Quantity needed to advance one unit, in gal.
2. Rate of flow per unit and step, in gal per min.
3. Time overlap when several supports are advanced simultaneously.

While a unit is advanced, the consumption of fluid varies from 6 to 9 gal/min and averages 7.5 gal/min. The variation depends on how much the canopies must be dropped, the resistance the units meet while advancing and whether voids above the canopies must be blocked. The wood is then compressed while the props are set. An operations study determined the frequency of simultaneous advances. It never happened that all jacksetters advanced supports simultaneously. Four out of six jacksetters advanced supports simultaneously at only 1.5 percent of the available time. The simulation showed that no more than three jacksetters must be considered. They consumed 26.5 gal/min during 3 percent of the available working time and the pump must be capable to supply fluid at this rate of 26.5 gal/min.

In the Ruhr district, 40 percent of the pump stations are stationary to supply one or more faces through 1- to 2-inch pipelines. The other 60 percent are portable stations that follow the faces at distances of 70 to 250 ft. They are installed on sleds or are hung on monorails. The usual operating pressure is 4,300 psi and pressure loss should not exceed 700 psi in a network. The largest size of hydraulic hose used at a longwall face is 3/4-inch-diameter size. The practice applied in 73 percent of all faces with powered supports in the Ruhr district is to have a straight hose line along the face with parallel branch lines tapped in to feed the supports. Distances between taps should not exceed 65 ft.

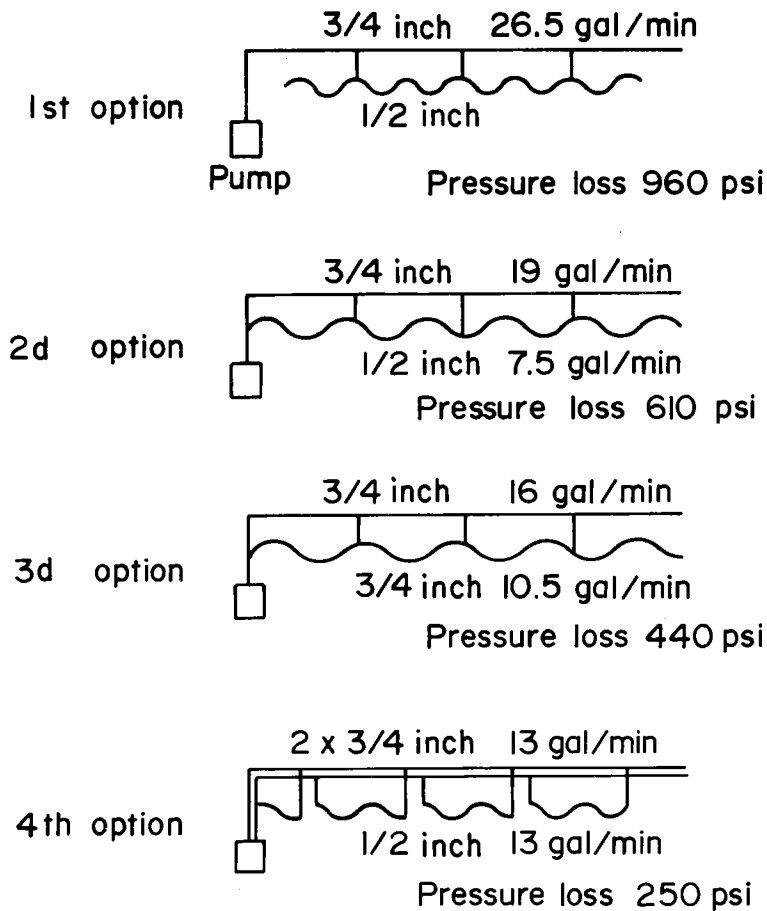

FIGURE 30. - Pressure loss with various supply systems.

each end. The pressure loss was only 250 psi.

Figure 30 shows the results of the Center's studies. The diagram indicates four options to supply a longwall face and the respective pressure losses. It refers to a face that was to produce 2,200 tons of clean coal in three shifts. The face was 730 ft long and the coalbed was 68 inches thick. The supports were installed on 60-inch centers and advanced in 25-inch-wide steps. If the shearer exposed 4,100 sq ft of roof area in three cuts per shift, six men were able to keep up the face support. The pressure loss shall not exceed 700 psi when 26.5 gal/min are supplied. It exceeded this value at the first option with a straight 3/4-inch hose line and 1/2-inch tap lines. The other three options offered acceptable pressure losses, and, of course, the fourth option was the best with two parallel straight 3/4-inch hose lines and 1/2-inch branch lines tapped in at

GROUND CONTROL RESEARCH WITH MINE MODELS

The Research Center for Roof Support and Rock Mechanics proved that rock deformation and failure under the effect of mining can be simulated in mine models of the type designed by the Center (fig. 31). The model scale is 1:10 for size and strength and all other dimensions are derived accordingly. For instance, the scale for the area would be 1:100, for the volume, weight, or mass 1:1000, and for the moment of inertia, 1:10,000.

A filler of quartz powder is mixed with Portland cement, quick-setting alumina cement and water in proportions to prepare materials that have the scaled-down strength of sediments from the Carboniferous such as sandstone, sandy shale, shale, and firm, medium-hard, and soft coal. Separation planes are also formed. Slickensided slip planes, where often strata movements take place, are represented in the model by paraffin-coated surfaces with a friction coefficient of 0.3 according to measurements on rock samples from

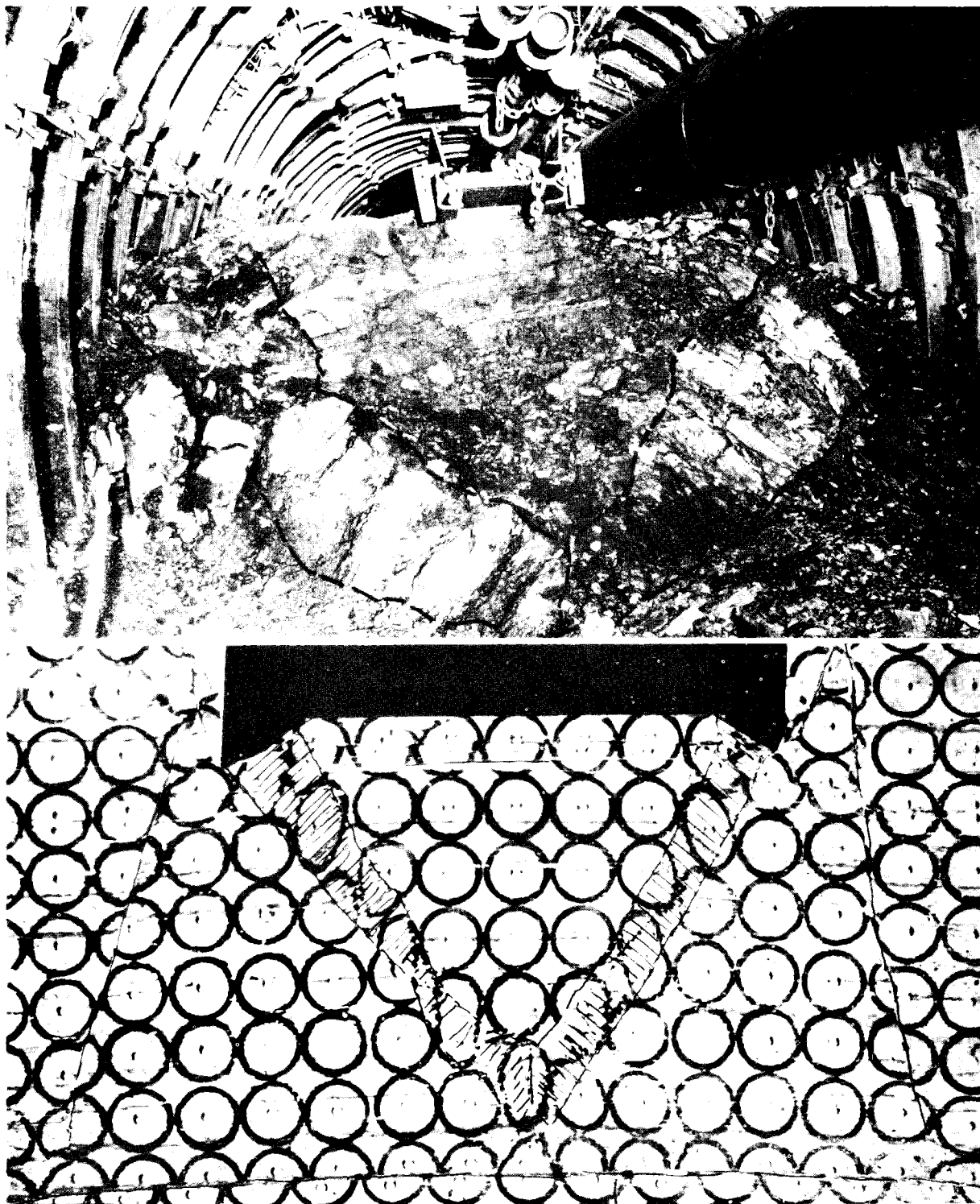

FIGURE 31. - Floor heave underground and in a model test.

underground. Ordinary bedding planes have a friction coefficient of 0.9 in nature and in the model.

Scaled-down roof supports are made from aluminum and balsa wood. Hydraulic prop models receive a nitrogen filling that is pressurized according to the required setting load. Models of fully and partly resin-anchored rock bolts are also provided.

Two test stands for triaxial loading by 66-ton hydraulic rams are available. One can hold an 80- by 80- by 16-inch model in prone position for investigation of gate roads. The other stand accommodates a 400- by 80- by 16-inch model in upright position, representing a longwall face.

Pressure and piston travel of loading rams are electrically controlled. Strain gages are attached to critical locations at the model and the measurements are transmitted to a data acquisition system. Front plates must be removed at each completed phase of a test so that the model can be photographed.

The underground pressure is assumed to be hydrostatic at a cover of 2,000 to 4,000 ft and the model is loaded accordingly. Additional loads due to mining act normal to the strata. They may amount to four times the cover load and are also imposed on the model by the rams.

A number of investigations with mine models were completed in recent years such as the effect of support capacity on roof cavities and steps, and the effectiveness of roof bolts in heavily stressed roadways. The results were of great practical importance. An increase of the support capacity from 2 to 6 tons/sq ft favorably affects the roof of a longwall face (13). Roof bolts should be resin-anchored at full length and installed on not more than 40-inch centers in a fanlike pattern. Their length should be equal to one-half of the road width where bolts are used exclusively and equal to one-third of the road width where bolts are combined with steel sets (4).

CONCLUSIONS

The Essen Research Center's roof and support evaluation program is tailored to the needs of an industry that mines only by longwall methods and still uses single props at the majority of faces. Accordingly, expanded mechanization of roof support at the face and stable roadways define the basic need of the coal industry in its struggle for improving productivity.

The situation in the United States is totally different. Longwall mining is in the growth stage. Powered supports are used exclusively and they are of much higher load capacity than those in Europe. American miners insisted on high support capacities from the very beginning to control a roof under the varying cover of mountain ranges. Obviously their insistence has been rewarded and even caused European miners to revise their standards by introducing jacks with a yield load of 110 tons at a growing rate.

Recent foreign visitors to American longwall operations confirm that most faces are adequately supported, but that roof control at face ends is far from satisfactory at some mines and that many entries deteriorate under the effect of mining. Apparently roof bolting and reinforcement by cribbing is not effective in keeping the floor from heaving and the roof from caving. Large chain pillars provide protection, but involve coal losses and possible rib line effects in underlying coalbeds when these are mined at some future time.

It is in those entries where a modified version of the German Research Center's roof surveillance techniques may find application in monitoring efforts to keep the roads open. Measures that proved successful in maintaining roadways in European mines are support by resin bolts anchored at full length with side bolts angled above the ribs and rows of single hydraulic props that by virtue of early bearing capability control convergence better than late bearing cribbing. Yielding arches are very costly to install and should be used only as a last resort. Roadside packs from anhydrite or other hydraulic material proved very effective in reinforcing gate roads in Germany. Their use in supporting weak ground should be investigated.

Methods to improve the preventive maintenance of the hydraulic system could also be applied in the United States. Though operating pressures in American mines are much lower than in Europe, leaks appear to be frequent. Ultimately operating pressure may drop below the threshold of effectiveness.

It is suggested that the Bureau seek cooperative agreements with interested coal operators to train their personnel in collecting roof surveillance data and that key data from the surveys be stored and made available to the industry.

REFERENCES⁴

1. Becker, H. Die Staubbekämpfung im Abbau, insbesondere in Rückbaustreben (Dust Control in the Face, Particularly in Retreating Longwall Operations). Glückauf, v. 107, No. 24, Nov. 25, 1971, pp. 911-918.
2. Brinkmann, E., and P. Matthias. Die Grubenwarte als Hilfsmittel der Betriebsüberwachung (The Control Center as a Tool for Operations Surveillance). Glückauf, v. 108, No. 1, Jan. 6, 1972, pp. 13-19.
3. Buschmann, N. Die Wirksamkeit von Gebirgsankern in druckhaften Strecken (Effectiveness of Rock Bolts in Heavily Stressed Roadways). Pres. at Bochum in a series of scientific, technical lectures. Mar. 16, 1970 20 pp.
4. _____. Der erforderliche Ausbauwiderstand in breiten Rechteckstrecken in einem Gebirge mit einheitlicher mittlerer Festigkeit und ohne Gleitlösen (The Required Support Capacity in Wide Rectangular Roadways in Strata of Uniform Medium Strength and Without Slip Planes). Glückauf, Forschungsheft No. 6, v. 31, Essen, December 1970, 5 pp.
5. Everling, G., and O. Jacobi. Angewandte Gebirgsmechanik. Forschungsvorhaben 1970-71, Abschlussbericht, Bergbau-Forschung GmbH, Forschungsstelle für Grubenausbau und Gebirgsmechanik (Applied Rock Mechanics, Research Project 1970-71, final report, Mining Research Company, Research Center for Roof Support and Rock Mechanics). Bergbau-Forschung GmbH, Essen 1972, 73 pp.
6. Glückauf. Technische Umschau: Wettertechnische Massnahmen für Hochleistungsstreben mit starker Ausgasung (Technical Review: Measures To Improve the Ventilation of High Production Faces With Strong Gas Liberation). Glückauf, v. 106, No. 10, May 14, 1970, pp. 469-472.
7. Henrich, F. Bergtechnische Erfahrungen mit Ausbaustreckenbegleitdämmen aus Anhydrit und Blitzdämmer (Mine Technical Experience With Roadside Packs From Anhydrite and Blitzdammer). Glückauf, v. 107, No. 2, Jan. 23, 1971, pp. 51-63.
8. Herwig, H. Die Grundlagen der Strebüberwachung (Principles of Longwall Surveillance). Pres. at 3d session of Task Force for Roof Support and Rock Mechanics, Essen, Germany, June 29, 1971; Bergbau-Forschung GmbH, 14 pp.

⁴Titles enclosed in parentheses are translations from the language in which the item was published. All foreign references are available for examination at Bureau of Mines Roof Support, Pittsburgh Mining and Safety Research Center, Pittsburgh, Pa.

9. Herwig, H., and O. Jacobi. Die Wirkung des Schreitausbaus auf das Hangende in Bruchbaustreben (The Effect of the Powered Support on the Roof at Caving Longwall Faces). Glückauf, v. 107, No. 22, Oct. 28, 1971, pp. 841-849.
10. Hess, H. Der Schildausbau, ein Beitrag zur weiteren Rationalisierung in Streb (Powered Shields, a Contribution to Further Mechanization at the Longwall Face). Glückauf, v. 108, No. 2, Jan. 20, 1972, pp. 60-65.
11. Irresberger, H. Bauform und Hydraulik des Schreitausbaus für den Deutschen Steinkohlenbergbau (Design and Hydraulics of the Powered Support in the German Coal Mining Industry). Glückauf, v. 106, No. 12, June 11, 1970, pp. 577-584.
12. _____. Der Stand des folgegesteuerten und des automatischen Strebausbaus (State of the Art of the Sequence Controlled and Automatic Powered Support). Glückauf, v. 105, No. 5, Mar. 6, 1969, pp. 206-208.
13. Jutb, W. Der Einfluss des Ausbauerstandes auf Hangendestufen und Ausbrüche in einem Modell (The Effect of the Support Capacity on Roof Steps and Cavities in a Model Test). Glückauf, Forschungsheft, No. 3, v. 32, Essen, June 1971, 5 pp.
14. Kammer, W. Verbesserung des Ausbauerfolges durch Streckenüberwachung (Improvement of Roof Support by Gate Road Surveillance). Pres. at 3d session of Task Force for Roof Support and Rock Mechanics, Essen, Germany, June 29, 1971, Bergbau-Forschung GmbH, 14 pp.
15. Krahe, Jürgen. Die hydraulische Versorgung von Streben mit Schreitausbau (The Hydraulic Supply of Longwall Faces With Powered Supports). Glückauf, v. 107, No. 9, Apr. 29, 1971, pp. 332-338.
16. Kukuk, H. R., and F. Claes. Besserer Zuschnitt durch Ausrichtung im Flöz (Better Mine Layout by Development in the Coalbed). Glückauf, v. 105, No. 21, Oct. 16, 1969, pp. 1041-1047.
17. Landesoberbergamt Nordrhein-Westfalen. Richtlinien für die Anwendung des Kohletränkverfahrens vom 19. März 1971 (State Mine District Office NRW. Guidelines for the Application of Water Infusion of March 19, 1971). Bellmann, Dortmund, Germany, No. 142, 1971, 3 pp.
18. Mayer, J. Betriebsüberwachung des schreitenden hydraulischen Strebausbaus auf dem Kohlenbergwerk Peissenberg (Preventive Maintenance of Powered Supports at Peissenberg Coal Mine). Westfalia Reporte, Altlünen, Germany, November 1968, 11 pp.
19. Nocke, H., and F. Schuermann. Der Vortrieb von Abbaustrecken mit Ankertürstockausbau (Driving Gate Roads With Combined Roof Bolting and Timbering Support). Glückauf, v. 107, No. 17, Aug. 19, 1971, pp. 642-651.

20. Oberbergamt Dortmund. Richtlinien des Oberbergamtes Dortmund für die betriebsspanmässige Zulassung von Strebbruchbau vom 26. Mai 1966 (Guidelines of the Mine District Office in Dortmund for the Approval of Caving Longwall Operations of May 26, 1966). Bellmann, Dortmund, Germany, No. 225, 1966, 35 pp.
21. Olaf, J. Stand der Grubenwartentechnik im Jahre 1971 (Status of Control Center Technology in 1971). Glückauf, v. 107, No. 25, p. 960.
22. Ortsack, W. Der Steinkohlenbergbau der Bundesrepublik Deutschland im ersten Halbjahr 1972 (Coal Mining in the Federal Republic of Germany in the 1st Half of 1972). Glückauf, v. 108, No. 20, Sept. 28, 1972, pp. 952-954.
23. Paul, K. Begrenzung der Betriebsfördermenge durch Methanausgasung (Limitation of Face Production by Methane Liberation). Glückauf, v. 105, No. 23, Nov. 13, 1969, pp. 1154-1169.
24. Rätz, B. W. Der technische Stand des schreitenden Strebausbaus im Deutschen Steinkohlenbergbau (Powered Roof Supports in German Coal Mines, a State of the Art Report). Glückauf, v. 103, No. 13, June 22, 1967, pp. 620-628.
25. Schuermann, F., A. Jankowski, and R. Novotny. Die Weiterentwicklung des Klebeankers (Further Development of the Resin Bolt). Glückauf, v. 106, No. 24, Nov. 26, 1970, pp. 1145-1151.
26. _____. Messung des Gebirgsverhaltens und der Wirksamkeit der Anker in Anker-Türstock-Strecken (Measuring Ground Stresses and the Effectiveness of Roof Bolts in Roadways Supported by Combination Roof Bolting and Timbering). Symp. at the Internat. Society of Rock Mechanics Convention at Nancy, France, October 1971, 19 pp.
27. Siddall, N. Keeping Dust Down While Mining 1,000 Tons per Shift per Face. Min. Congress J., December 1970, pp. 45-51.
28. Von Eicken, K., and H. Becker. Weiterentwicklung der Hochdrucktränkung und der dabei benutzten Geräte und Armaturen (Development of High Pressure Infusion and Equipment and Fittings Utilized). Bergfreiheit, special reprint, No. 4, 1962, 16 pp.
29. Weber, H., U. Grotowski, W. Götze, J. Krahe, H. J. Geffroy, W. Kammer, D. Schröer, G. Everling, H. Buschmann, and W. Breer. Fortschritt im Ausbau von Abbaustrecken (Progress in Gate Road Roof Support). Meeting of the Task Force for Roof Support and Rock Mechanics at Essen on May 2, 1972. Glückauf, v. 108, No. 22, Oct. 26, 1972, pp. 1005-1029.
30. Wild, H. W. New Plowing Techniques Increase Production Potential in West German Coal Mines. Min. Congress J., December 1969, pp. 59-65.
31. Winter, K. Gasabsaugung (Methane Drainage). Bergbau, special reprint, No. 9, 1958, 16 pp.

APPENDIX

TABLE A-1. - Operational data from 23 longwall faces in the Federal Republic of Germany and 1 longwall face in France

Face No.	Coalbed	Rank	Thickness, inches	Dip, degrees	Face length, ft	Depth, ft	Shift, hrs	Crew per mining equipment	Armored face conveyor	Roof support; yield per leg, cobs	Ventilation	Methane drainage	Water infusion	System	Driving	Gate roads	Reinforcement	Remarks
1	Zollverein 5	Medium-volatile	42	20° NW	900	2,450-2,750	1,100 (3 mining, 1 repair)	120 Westfalia G16thobel, 340 fpm.	Westfalia double chain, in-face anchorage.	Hemsheldt double frames, 66.	Descending with flow of coal.	NA	NA	Advancing.	Blasting Saizgitter side dump loader.	Three segment yielding arches.	Cribbing.	Cavities and cleavages occurred under rib lines of water barrier pillars left standing against the Cretaceous cover in 3 overlying coalbeds. Also the shale roof was thinning out under firm sandstone.
2	Gustav	Low-volatile "fat" coal	60	NA	670	2,800	1,850 (2 mining)	NA Westfalia hookplow, 180 fpm.	Westfalia double chain.	Westfalia double frames, 66.	do	Yes	do	do	Blasting Emco side dump loader.	Yielding arches.	do	Source of CH ₄ was overlying Katharina coalbed tapped by 200-foot-long drainage holes; 60 to 100 percent CH ₄ ; 14-inch gas mains; 100-inch WG suction pumps.
3	Hugo	do	58	9° SE	830	2,400	NA	NA Westfalia hookplow, 340 fpm; leaving 4 inches of roof coal.	do	Hemsheldt double frames, 44/66.	Ascending.	Yes	do	do	Blasting side dump loader.	do	do	Cavities; roof coal dropped between the supports and had to be removed before the supports could be advanced.
4	E/F	High-volatile	92	6° N	840	3,130	4,700	200 Eickhoff shearer EDW 170 L; 60 gal/min; 32- by 64-inch drum.	Halbach and Braun single chain, shift rams, 260 fpm.	Hemsheldt double frames; floor and top shift rams, 110.	do	Yes	Retreat	NA	Three segment yielding arches.	Anhydrite road pack; hydraulic props under VM bars.	Crumbling draw rock above canopies was held by Stapa wire, a paper-backed wire mesh.	
5	Albert 1/2	Low-volatile "fat" coal	62	5° SE	714	1,700	2,400	100 Westfalia hookplow, 160/320 fpm; Beien chain guide.	Westfalia double chain.	Hemsheldt double frames, 44/66.	do	NA	Z-system	Tailgate blasting 88U Joy loader.	17 by 8 ft rectangular steel legs; center post; cribbing.	Cribbing; hydraulic props under VM bars.	Posco and Alpine partial face tunnel drivers were in use.	
6	N	High-volatile steam coal	106	6° NW	730	1,300	3,500	NA Eickhoff shearer, ER4 shuttle plow.	Westfalia	Hemsheldt double frames; floor and top shift rams, 100.	do	Yes	Advancing.	Blasting slusher.	17 ft and 14 trapezoidal; yielding legs; center post.	do	Weak rock above canopies was held by 3/16-inch wire mesh. The mats were tied together by strong connectors.	
7	Zollverein 2, Zollverein 3	Medium-volatile	72-105	NA	600	2,900	1,550 (3 mining)	NA Westfalia pupil hookplow; hydraulic height adjustment; Beien chain guide.	Westfalia triple chain.	Hemsheldt double frames; floor and top shift rams; design for pneumatic stowage; canopies extended over gob, 66.	do	Yes	Advancing; pneumatic stowage Brieden machine.	Blasting slusher; Emco side dump loader.	Yielding arches.	Cribbing.	Washer refuse was dropped in skips and carried on belts to stowing machine Brieden and sent from there to the face through 9-inch pipes with telescopic joints. The ejectors were remotely controlled. A floor digging machine was used to lower the main gate floor that had heaved.	
8	Röttgersbank	Low-volatile "fat" coal	107	18° S	630	2,950	1,900	NA Beien megaplow, 100/280 fpm.	Beien slanted, 60/120 fpm	Westfalia double frames; double shift rams, 77.	do	NA	Retreat	NA	Four segment yielding arches.	Hydraulic props under VM bars.	Wire mesh was stretched over the canopies to hold the weak shale. But the mats were poorly tied and much rock dropped out. Stables were driven by blasting, the coal was loaded by slushers and the roof was supported by hydraulic props under VM bars.	
9	Bibener	Low-volatile "fat" coal	44	32° N 9° S	370-400-770	2,400	1,200 (2 mining)	120 Westfalia hookplow.	Halbach and Braun single chain.	Ferromatik double frames; with flow of coal.	Descending with flow of coal.	NA	Face, 13 ft deep.	Z-system	Blasting slusher.	Yielding arches.	Cribbing.	Four inches of drawrock dropped out, but clung to the roof at spots. Some supports became near solid. Roof deteriorated along a stretch of 100 ft due to inadequate support by misaligned units. The alignment chain to which the guide ropes were hooked was not properly tensioned. The tail gate road was retimbered and the floor was brushed.
10	Dickebank	do	100 (mined under a roof of rash)	5°	670	2,900	3,000	NA Eickhoff shearer, EDW 170 L, ER4 shuttle plow.	do	OBV shields; Ferromatik legs and hydraulics, 77.	do	NA	Advancing.	Blasting Saizgitter side dump loader.	Four segment yielding arches.	do	The shields controlled a weak roof that had posed severe difficulties to mining with single props and pneumatic stowage. But ventilation and dust control are limited by the available minimum cross section of 50 ft ² .	
11	Drei und zwanzig (twenty-three)	Low-volatile byproduct	51	NA	730	2,000	1,150	120 Westfalia S plow; Saar chain guide	Westfalia triple chain.	Ferromatik chocks, 66.	Ascending.	Yes	Face, 15 ft deep; wetting agent.	Z-system	Tailgate blasting Saizgitter side dump loader.	Trapezoidal; yielding arches; three segment arches.	Anhydrite road pack; 2,500 psi in compressive strength.	Plow and chock combination is rare. The face advance was 10 ft per day. Rockbolts, 8 ft long and 5/8-inch diameter, resin-anchored and installed slightly slanting above the coal stabilized the weak drawrock in spots. Methane liberation, 1,250 cu ft per ton of clean coal, is very high. The mine returns still carry a CH ₄ concentration of 0.9 percent. Gas mains, 14 and 16 inches in diam, conduct the drainage to surface pumps operating under 100 inches of depression.
12	Röttgersbank 2	Low-volatile "fat" coal	90	45° NW	700	1,900-2,300	1,400 (2 mining)	NA Beien megaplow, 100/320 fpm.	Beien slanting; 270 fpm, Glückauf anchorage station.	Westfalia triple frames; double shift rams and four steering rams, 77.	do	Yes	No; hazard on steep pitch.	Retreat	NA	Yielding arches.	Cribbing; hydraulic props under VM bars.	Pieces of old flat shaft tail ropes were attached to the flushing shields to keep the rock out. A special unit was designed to anchor the conveyor on the steep pitch. When the roof supports were installed, they were lowered and swung in place by two hoists. Stables were driven by blasting, and the roof was supported by hydraulic props.
13	Merl	Anthracite; domestic use; 1.45 specific gravity.	31	5° E	750	950-1,100	1,400 (3 mining)	76 Westfalia G-plow.	Westfalia	Westfalia double frames, 60/35.	Descending with flow of coal.	No	do	do	NA	Trapezoidal steel support.	NA	Gate road advances of 650 ft/month were not unusual to keep pace with the faces retreating at a rate of 20 ft per day. The roadway net measured 56 miles. Full face tunnel drivers were used.
14	N or Graueck	Byproduct	85	11° W	580	1,900	NA	NA Westfalia G-plow; Beien chain guide, 100/300 fpm.	Westfalia double chain, 180 fpm.	Westfalia double frames, 77.	Ascending.	Yes; floor holes at 45°.	do	NA	Arches; trapezoidal steel sets.	NA	Development in coal.	

See footnotes at end of table.

TABLE A-1. - Operational data from 23 longwall faces in the Federal Republic of Germany and 1 longwall face in France--Continued

Face No.	Coalbed	Rank	Thickness, inches	Dip, degrees	Face length, ft	Depth, ft	Shift, tons per day	Crew per Mining equipment day	Armored face conveyor	Roof support; yield per leg, tons	Ventilation	Methane drainage	Water infusion	System	Driving	Support	Reinforcement	Remarks
15	C.....	High-volatile steam coal	67	5° N	730	2,800	NA	NA Westfalia hookplow.	Westfalia..	Hemscheidt double frames; floor shift rams, 66.	...do.....	NA	NA	NA	NAP	-	NA	Large sandstone blocks dropped on the supports and inflicted extensive damage. Props were knocked out of alignment. Canopies were broken off. Welding seams were opened and leaf springs were broken. The coal height fluctuated and obviously the props had not been extended in time to match the height.
16	Erda.....do.....	70	13° NW	760	1,800	2,400	100 Westfalia hookplow, 320 fpm.	Halbach and Braun single chain; 140 fpm; in-face anchorage by 5 rams.	Hemscheidt double frames; top and floor shift rams, 110.	...do.....	Not needed.	60-ft face holes.	Z-system..	Main gate; blasting Eimco side dump loader.	Yielding arches; rectangular steel sets.	Cribbing from railroad ties.	Developed in coal. The face advanced at a rate of 17 ft per day. Guide rods kept the supports aligned in the undulating coalbed. The infused water hit a kaolin parting that swelled and loosened the coal so that the plowability was improved. Stables were driven by blasting and supported by hydraulic props with bars.
17	Schwalbach.....	High-volatile steam coal.	102	9° NW	705	1,000	2,450 (4 mining)	105 Eickhoff shearer, EDM 170 L.	Halbach and Braun single chain.	Hemscheidt double frames; floor and top shift rams, 100	Ascending..	No.....	No.....	Retreat...	NAP	Yielding.....	Hydraulic props under VW bars.	Weak roof posed a problem at the start of the face. Waterglass injection was tried, but abandoned. Eventually the roof was stabilized by filling a roof cavity 15 by 25 by 115 ft with an anhydrite plug.
18	Elizabeth.....do.....	91	14° N	600	1,700	1,650	40 Eickhoff shearer, EDM 170 L; Westfalia hookplow to clean floor.do.....	Hemscheidt double frames; floor and top shift rams, 77.	...do.....	Yes.....	Face 15 ft; gate road; 200 ft.do.....	NAP	Rectangular 10 by 17 ft; wire mesh lagging.do.....	Roof bolts, 63- by 3/4-inch diameter were anchored full length with Celcrite resin into the roof of roadways and installed with shells in the coal ribs. Roads were driven by blasting and slusher work at a rate of 200 ft per day for the entire mine to prepare faces for retreat mining. The shearer cuts out to the main gate face end. The tail stable was driven by blasting. The coal was loaded with small slushers on the AFC.
19do.....do.....	91	14° N	575	1,700	900	68do.....	Rheinstuhl double chocks; shift rams between chocks, 66.	...do.....	Yes.....do.....do.....	NAPdo.....do.....	Many roof cavities occurred at the face. The hydraulic system was leaking at many spots.
20	H.....	-	75	NA	1,000	NA	2,200	NA Anderson-Boyes bidirectional shearer; fixed drum.	French-made double chains attached to the extended rear points of the flight	Hemscheidt double frames; floor and top shift rams; extended rear canopy, 44.	...do.....	NA	NA	Retreat...	NAP	Yielding arches.do.....	Pneumatic stowage was used to control water influx and gas accumulation. The washer refuse was carried to the stowing machines by a belt system whose speed could be adjusted according to the demand. The belt was turned 180° at both terminals to prevent fouling of the idlers by the sticky material. The face arrangement was the same as described under No. 7. The ejectors were controlled remotely by hydraulic means. Hydraulic leaks were frequent and the stowage did not keep pace with the face advance. This affected roof control adversely. Wire mesh was stretched over the canopies to hold the fragile shale. A power-center got squeezed between deformed arch segments in a belt road that had crossed a fault and suffered convergence and water influx.
21	Wilhelm.....	Low-volatile "fat" coal	79	34° N	400	2,500	NA	NA Westfalia hookplow pulpit type.	Westfalia double chain; Klerner anchor station; in-face anchorage.	Hemscheidt triple frame, 77.	...do.....	Yes.....	Face, 15 ft.	Z-system..	Blasting Saizgitter side dump loader; 180 sq ft.do.....do.....	Gas liberation was a problem at this mine that was the scene of an explosion in 1946 with a toll of 400. But the Ida coalbed, the greatest source of gas, was nearly worked out. Gas liberation may decline after mining of Ida is completed.
22	Chriemhilt.....	High-volatile blended with "fat" coal for coking.	92	3°	840	1,850	2,750 (3 mining)	87 Eickhoff shearer, EDW 200 L; ER4 shuttle plow.	Halbach and Braun single chain.	Rheinstuhl double chocks, floor and top shift rams; steering rams, 77.	...do.....	No.....	No.....	Retreat...	NAP	Trapezoidal; steel bars; wood legs; side roof bolts.do.....	Chocks were shifted under slight pressure against the roof. Whenever a middle man exceeded 1 ft in thickness, the roof deteriorated. Wood bolts, 1-3/4 inches thick and 8 ft long, were installed in the face at midheight in an effort to straighten the sloped coal face. The mine was developed in coal. The roadways were driven with Joy 6CM continuous miner and shuttle cars. American-style multiple entries and room and pillar mining has been tried but abandoned because of adverse roof conditions. Panels reached 3,500 ft in length, but had to be shortened where the coalbed split. The minable upper bank was too low for the available equipment.
23	Zollverein 7....	Medium-volatile.	95 (mined above a floor of rash)	6°	430	2,200	1,300	NA Eickhoff shearer, EDW 170 L.do.....	Gullick double five-leg chocks; each of four, 77; forward leg, 110.	...do.....	NA	NA	Advancing.	Blasting side dump loader.	Yielding arches.do.....	Only the upper bank of the coalbed was minable. The chocks advanced on a coal floor. Large floor plates kept the floor bearing pressure to less than 210 psi. The fifth or front jack with a extensible forepoling bar brought high support capacity close to the face. The tail gate road was driven flush with the longwall face; the main gate road was kept ahead.

NA Not available.
NAP Not applicable.
WC Watergate.
VW Vanwersch
AFC Armored face conveyor.