

A mining research contract report
APRIL 1987

Open File Report
35-87
1987-35

U.S. DEPARTMENT OF LABOR MSHA



00031350

SYSTEMS APPROACH TO MINE FIRE SAFETY

U.S. Bureau of Mines
Minneapolis, Minn.

JUN 15 1987

LIBRARY

Contract J0100053

U.S. Department of Commerce
National Bureau of Standards

BUREAU OF MINES
UNITED STATES DEPARTMENT OF THE INTERIOR



OFR
87-35

The views and conclusions contained in this document are those of the authors and should not be interpreted as necessarily representing the official policies or recommendations of the Interior Department's Bureau of Mines or of the U.S. Government.

REPORT DOCUMENTATION PAGE		1. REPORT NO.	2.	3. Recipient's Accession No.
4. Title and Subtitle SYSTEMS APPROACH TO MINE FIRE SAFETY			5. Report Date April 1987	6.
7. Author(s) Jeffrey A. Shibe			8. Performing Organization Rept. No. NBSIR-86/3425	
9. Performing Organization Name and Address National Bureau of Standards Department of Commerce Gaithersburg, MD 20899			10. Project/Task/Work Unit No.	
			11. Contract(C) or Grant(G) No. (C) J0100053 (G)	
12. Sponsoring Organization Name and Address U.S. Department of the Interior Bureau of Mines Pittsburgh, PA 15236			13. Type of Report & Period Covered Final Report June 1980 - April 1987	
14.				
15. Supplementary Notes				
16. Abstract (Limit: 200 words) A prototype Fire Safety Evaluation System has been developed and is ready to be evaluated by a Peer Consulting Panel and for performing field tests. The system can be used to determine combinations of widely accepted fire safety equipment and underground coal mine features that provide a level of safety equivalent to those required by the Code of Federal Regulations-Title 30 for underground coal mines. In this evaluation, equivalent safety performance is gauged in terms of overall level of safety provided rather than by a component by component comparison.				
17. Document Analysis a. Descriptors coal mines; fire hazards; fire safety; Fire Safety Evaluation System; life safety				
b. Identifiers/Open-Ended Terms				
c. COSATI Field/Group				
18. Availability Statement Release Unlimited		19. Security Class (This Report) Unclassified		21. No. of Pages 146
		20. Security Class (This Page) Unclassified		22. Price

FOREWORD

This report was prepared by the U.S. Department of Commerce, National Bureau of Standards, Gaithersburg, Maryland under USBM Contract number J0100053. The contract was initiated under the Health and Safety Technology Program. It was administered under the technical direction of the Pittsburgh Research Center with Jeffrey H. Welsh as the Technical Project Officer. Oliver H. Snyder III was the Contracting Officer for the Bureau of Mines. This report is a summary of the work recently completed as a part of this contract during the period June 1980 to April 1987. This report was submitted by the authors in April 1987.

TABLE OF CONTENTS

	<u>Page</u>
ABSTRACT.....	1
1. INTRODUCTION.....	1
2. BACKGROUND.....	2
2.1 Underground Coal Mines.....	2
2.2 Fire Safety Evaluation System.....	3
3. THE DEVELOPMENT OF AN EVALUATION SYSTEM	3
4. DEVELOPMENT OF THE FSES.....	6
4.1 Fire Safety Parameter Identification.....	6
4.2 Fire Safety Parameter Quantification.....	8
4.3 Redundant Safety Subsystem.....	8
4.4 Calibration.....	10
4.5 Professional Judgement.....	10
4.6 Computer Program.....	11
5. FUTURE RESEARCH.....	12
6. SUMMARY.....	14
7. REFERENCES.....	15
APPENDIX A - FSES FOR UNDERGROUND COAL MINES.....	30
APPENDIX B - DELPHI PROCESS.....	44
APPENDIX C - PEER CONSULTING GROUP.....	53
APPENDIX D - A QUALITATIVE ANALYSIS OF THE INHERENT FIRE SAFETY/FIRE RISK SYSTEM IN A COAL MINE.....	56
APPENDIX E - STATUS REPORT ON TRIAL COMPUTERIZATION AND ANALYSIS OF FIRE INCIDENT DATA.....	136

SYSTEMS APPROACH TO MINE FIRE SAFETY

Jeffrey A. Shibe

Center for Fire Research
National Bureau of Standards

Abstract

A prototype Fire Safety Evaluation System has been developed and is ready to be evaluated by a Peer Consulting Panel and for performing field tests. The system can be used to determine combinations of widely accepted fire safety equipment and underground coal mines features that provide a level of safety equivalent to those required by the Code of Federal Regulations-Title 30 for underground coal mines. In this evaluation, equivalent safety performance is gauged in terms of overall level of safety provided rather than by a component by component comparison.

Key words: coal mines; fire hazards; fire safety; Fire Safety Evaluation System; life safety.

1. INTRODUCTION

At the request of the Bureau of Mines, the Center for Fire Research at the National Bureau of Standards developed a prototype Fire Safety Evaluation System (FSES) for Underground Coal Mines. The Fire Safety Evaluation System is designed to assure the same level of fire safety as is obtained by meeting relevant portions of the Code of Federal Regulations--Title 30 for underground coal mines.

For the prototype FSES to achieve operational status, two additional steps are required. One, the system has to be evaluated by a Peer Consulting Panel. And two, after the system is accepted by the panel, the system must be field tested.

Use of the FSES offers more flexibility than strict conformance with the specifications in CFR-Title 30. It identifies combinations of widely accepted fire safety features and systems which, collectively, provide a level of safety equivalent to or greater than that achieved by meeting relevant specifications in Code of Federal Regulation-Title 30 for underground coal mines.

The prototype Fire Safety Evaluation System for Underground Coal Mines is presented as an Appendix A of this report.

2. BACKGROUND

2.1 Underground Coal Mines

The federal government set mandatory safety requirements for coal mining operations in the early 1970's. The standards, are set in Title 30 of the Code of Federal Regulations (CFR-30). The Federal Mine Safety and Health Amendments Act became law in 1977. There are two major changes in the 1977 Act.

One, Section 101 (c) modifies the procedure to grant a petition for modification of a safety standard. The petition requires that the mine

operator must show that an alternate method of achieving the intent of the standard exists that will at all times guarantee at least the same measure of protection afforded by the standard.

The second change in the 1977 law transferred the Mining Enforcement and Safety administration from Interior Department to the Labor Department and renamed it the Mine Safety and Health Administration (MSHA). Under the new law, MSHA alone has the responsibility for granting a petition for modification.

2.2 Fire Safety Evaluation System

The Center for Fire Research of the National Bureau of Standards (NBS) previously developed a series of Fire Safety Evaluation Systems for different occupancies. The FSES's were designed as an equivalent to specific occupancy chapters of the Life Safety Code or other codes. NBS has developed a Fire Safety Evaluation System for Health Care Facilities, Multifamily Housing, Board and Care, National Park Service Overnight Accommodations, Detention and Correctional Occupancies, and now Underground Coal Mines.

3. THE DEVELOPMENT OF AN EVALUATION SYSTEM

The objective of a Fire Safety Evaluation System is the development of a grading system for evaluation of the level of fire safety in an installation. In terms of coal mines the objective is to produce a numerical rating system

that balances those factors that reduce risk against those factors that increase risk.

The approach also includes additional considerations to assure an appropriate degree of safety redundancy, so that the failure of a single protection device or method will not result in failure of the entire safety system.

The end result must produce a level of safety that equals or exceeds that produced by explicit compliance with the regulations of CFR-30. Steps in the overall process are:

- (1) Identify problems and goals
- (2) Identify all the factors (i.e. mine characteristics and fire safety features) which significantly contribute to life safety with respect to fire
- (3) Establish variables (the various levels of performance possible in the parameters)
- (4) Set values for the variables (the relative impact on safety of each variable of each parameter)
- (5) Determine the dependence (where the value of variable depends upon the presence or absence of another)

- (6) Create redundant safety subsystems within the system to assure that failure of any one fire safety feature or method will not create an unacceptable decrease in fire safety
- (7) Calibrate to requirements in CFR-30
- (8) Professional judgment review and critique
- (9) Field testing of the system
- (10) Recycle

The tasks involved in system development were heavily dependent on professional judgment. The professional judgment of the project staff was supplemented and supported in a formal manner. Two consulting panels were formed to provide this support; the Delphi Panel and the Peer Consulting Panel. In addition, outside consultants were used to provide specialized experience in the general safety requirements in the CFR-30 and specific analysis of electrical systems.

Delphi Panel. A group of 34 experts from the Bureau of Mines, universities, Factory Mutual and Center for Fire Research, served as the Delphi Panel. They provided guidance in the selection of preliminary numerical values representing the relative importance of various fire safety features which are used in the operation of underground coal mines. Details regarding the

function and composition of this panel are contained in Appendix B of this report.

Peer Consulting Panel. NBS staff worked with a task group selected by the Mine Safety and Health Administration to provide advice to the staff and in-depth review of their work (See section 4.5).

4. DEVELOPMENT OF THE FSES

4.1 Fire Safety Parameter Identification

Phase 1 of FSES for a coal mine developed a qualitative description of the inherent fire safety/fire risk system in a coal mine. The approach consisted of the development of an event logic tree to analyze forces and countermeasures involved, and the development of a supporting state transition model to assist in identifying the states of fire development and human response potentially occurring in a mine fire. Output of Phase 1 provided the basic background for selecting fire safety parameters (see Appendix D - "A Qualitative Analysis of the Inherent Fire Safety/Fire Risk System in a Coal Mine").

The fire safety parameters are measures of the underground mine characteristics and fire protection features that bear upon the safety of the people who may be in the mine at the time of a fire. The safety parameters, selected by the project staff, were determined by examining the CFR-30 requirements, and by evaluating the impact of various elements of the Code.

The selected safety parameters were modified first by the Delphi Panel and later by the Peer Consulting Panel. The preliminary safety parameters are shown in Figure 1.

For each safety parameter, two or more levels or categories were defined. Each category corresponded to a condition specifically identified as a level of performance in the CFR-30 and/or likely to be encountered in underground coal mines. Each category differed from all the other categories in a significant way. For example, one parameter was defined as "Special Hazards" and the four categories are: Remote From Work Areas and Escapeways - Protected; Remote From Work Areas and Escapeways - Not Protected; Exposed to Work Areas and Escapeways - Protected; Exposed to Work Areas and Escapeways - Not Protected.

Figure 2 shows the preliminary "matrix" form of the breakdown of the safety parameters for the underground coal mines. The safety parameters are designed to constitute a complete assembly of all the basic mine factors determining the level of safety in an underground coal mine for which equivalency could be expressed.

In addition to the safety parameters and their subcategories illustrated in Figure 2, there is an additional series of items required by the CFR-30 for which no equivalency could be expressed. These items, illustrated in Figure 3, related primarily to services and electrical equipment and are covered in the Mine Fire Safety Requirement Worksheet section of Fire Safety Evaluation System (Appendix A of this report).

4.2 Fire Safety Parameter Evaluation

The goal of the NBS research effort was to develop a system for evaluating the fire safety of an underground coal mine by obtaining weighted sums of the point values of the individual safety parameters. Therefore, each subcategory of each parameter had to be assigned a point value. In order to provide the best available consensus judgment and experience in determining the preliminary values, the Delphi panel was established.

Each member of the panel was provided with copies of an initial matrix as shown in Figure 2. Each person then evaluated the relative importance (i.e. assigned a point value) with respect to fire safety of each item in the entire matrix of parameter categories without consultation with other members of the panel. The members of the Delphi Panel were advised that the goal of the project was to develop a system that would provide an alternative evaluation of the fire safety in coal mines. See Appendix B for more detailed discussions of this operation and its methodological base.

4.3 Redundant Safety System Creation

A basic principle of fire protection is that there must be redundancy of protection so that a failure of a single protection device or method will not result in failure of the entire safety system. In addition, the development of a redundant approach, as used in this safety evaluation system, avoids the pitfall of traditional approaches sometimes used in grading systems where all of the elements are considered mutually exclusive of each other and a single

total score determines acceptability. It is possible under such a system to fail to detect the absence of a critical element. The evaluation system establishes redundancy on the basis of in-depth coverage of the principal fire safety methodologies.

Not all safety parameters apply in the same manner or degree in all portions of a coal mine, nor do they apply equally to the various fire safety methodologies. This system divides a mine into four basic sections: total mine, working place, intakes, and return.

The redundant methodology used in the system to achieve the fire safety objectives is divided into five sub-objectives:

- A. Prevent Explosions
- B. Prevent other Ignition
- C. Manage Smoke
- D. Manage Fire
- E. Provide Escape and Rescue

Sub-objectives A and B cover those portions of fire safety performance detailed in the "Preventions of Fire Initiation" branch of the event logic tree. (See Appendix D). Sub-objectives C and D similarly cover the "Threat Control" branch and sub-objective E covers the "Protect Exposed" branch.

Members of the Delphi panel judged the importance of each safety parameter to the separate fire safety methodologies of Prevent Explosions, Prevent Other

Ignition, Manage Smoke, Manage Fire, and Provide Escape and Rescue for each of the four mine sections. The Delphi results were processed and analyzed by the project staff at NBS and reviewed in subsequent conference meetings of the Delphi panel. By this process, the parameters that have a significant impact on each of the redundant methodologies were identified. Figure 4 shows the breakdown in terms of which parameters apply to which methodologies.

4.4 Calibration

Once the basic framework for the system was established, it was necessary to determine the level at which code equivalency is achieved. This was accomplished by "scoring" the Code of Federal Regulation - Title 30 requirements for underground coal mines using the evaluation system (Figures 5 and 6 illustrate this process for Working Place). Since requirements for other sections of mines vary from each other, the evaluation score varied accordingly. The results of this "scoring", illustrated in Figures 6-12, were incorporated into the evaluation system as the equivalency requirement values for achieving safety equivalent to the CFR-30.

4.5 Professional Judgement and Review

In order to provide an independent in-depth review of the work, the Peer Consulting Panel was formed. The panel first met after the staff had developed a form for rating and after values for the parameter categories were assigned based on the advice of the Delphi panel. The modus operandi for the Peer

Consultant Panel was to present candidate solutions that could be produced by the FSES and ask the panel members to appraise the relative safety of that solution to the safety provided by explicit compliance with the detailed requirements of CFR-30.

The Peer Consulting Panel consisted of individuals from the Mine Safety and Health Administration (MSHA) headquarters. NBS presented a general description of a fire safety evaluation program and a detailed description of a draft FSES for coal mines. The Peer Consulting Panel asked questions about general capabilities of the FSES as applied to coal mines as well as how it can be used to enforce specific coal mine safety regulations.

Peer Consulting Panel members informed NBS staff that MSHA is presently involved in several high priority projects and can not support this assignment. They could not predict when they will have the time in the future to support an analysis of the FSES. MSHA also stated that they are now in the process of changing the mandatory safety requirements. MSHA does not know the date when the changes will be incorporated in the official regulations. (See Appendix C for the names of the Peer Consulting Panel.)

4.6 Computer Program

A computer program was designed to evaluate the proposed FSES system and analyze potential proposed changes. This program generates all alternative combinations of coal mine safety features that the system will indicate as acceptable.

Since the evaluation system is theoretically capable of evaluating each of over 900 million combinations of the 14 safety parameters, it is important that the only combinations passing the system are those that provide a satisfactory level of protection. By using the computer output, the evaluator can review all acceptable solutions for upgrading a given coal mine, and can be assured that the combination of solutions to be reviewed is the complete set and not an unintentionally biased subset. The printouts of the combinations of safety features can be analyzed by an experienced individual to establish acceptability of solutions. The computer analysis was used as part of an interactive process of changing and checking in an effort to refine the system.

Examples from the computer selected acceptable coal mines configurations were presented to the Peer Consulting Panel to evaluate if the system gives acceptable evaluations. Each example was chosen such that some of its safety parameters had major safety deficiencies (such as a high methane level, single exit, no separation, etc.) compensated by safety parameters with high safety levels (such as increased levels of detection, coal dust control, emergency procedures, etc.).

5. FUTURE RESEARCH

Fire is one of the most serious hazards in underground coal mining. An underground fire can fill a mine with deadly carbon monoxide in minutes. This high contamination rate, coupled with long periods of time needed to evacuate

people from an underground mine, creates, in even a moderate sized fire, a significant potential for death and injury.

The Federal Bureau of Mines Report "IC-8830 gives a statistical analysis of surface and underground coal mines in the United States from 1955 to 1975. The study found that the majority of all mine fires were electrical in origin. Electrically ignited fires were the primary causes of underground fire injuries and the only cause of fire fatalities.

The primary power source in underground coal mines is electrical. The electrical power is distributed in both D.C. and A.C. The Delphi panel could not decide on the risk levels caused by electrical power. Nor could they decide which type of current would carry a higher risk level in the operation of an underground coal mine. Therefore, the code requirements for electrical power were not included in the set of parameters analyzed by the FSES.

The following electrical power code requirements are not included in the FSES parameters:

CFR-30-Task 75-Subtask F - Electric Equipment - General

CFR-30-Task 75-Subtask G - Trailing Cables

CFR-30-Task 75-Subtask H - Grounding

CFR-30-Task 75-Subtask I - Underground High-Voltage-Distribution

CFR-30-Task 75-Subtask J - Underground Low-and-Medium-Voltage

Alternating Current Circuits

CFR-30-Task 75-Subtask K - Trolley Wires and Trolley Feeder Wires

A research program to identify factors generated by the usage of different forms of electrical power, would provide further guidance on improving the level of fire safety in coal mines.

6. SUMMARY

A method has been developed and described for generating equivalency to a specified set of underground coal mine safety requirements. This method is based on the articulation of levels of coal mine safety and on the redundancy of safeguards. This method can provide the necessary flexibility enabling a coal mine operator to achieve minimum cost solutions for a specified level of safety.

The described method "Fire Safety Evaluation System for Underground Coal Mines" is a specific example of an equivalency to the code requirements specified in the Code of Federal Regulations-Title 30, July, 1981.

For the "Fire Safety Evaluation System for Underground Coal Mines" to be fully operational two additional steps are necessary: An evaluation by a peer consulting panel and field testing.

Electrical power risk factors, identified for a proposed research program, could also be incorporated in the Fire Safety Evaluation System for Underground Coal Mines. Such an updated FSES would have a capability to evaluate the overall level of fire safety in a coal mine.

7. REFERENCES

- [1] Anon, Allen Corporation of America, "An Annotated Bibliography of Coal Mine Fire Reports", February 15, 1979.
- [2] Christians, W.R., "Low Level Monitoring System for CO Concentrations in Belt Entries", Mining Congress Journal, January 1982.
- [3] "Coal Mine Fire and Explosion Prevention", Bureau of Mines Information Circular 8768, 1982.
- [4] Edwards, J.C. and Greuer, R.E., "Real-Time Calculation of Product-of-Combustion Spread in a Multilevel Mine", Bureau of Mines I.C. 8901, 1982.
- [5] Griffin, R.E., "In-Mine Evaluation of Underground Fire and Smoke Detectors", Bureau of Mines I.C. 8808, 1979.
- [6] Johnson, G.A. and Forshey, D.R., "In-Mine Fire Tests of Mine Shaft Fire and Smoke Protection Systems", Bureau of Mines I.C. 8783, 1978.
- [7] Johnston, A.G., McQuaid, J. and Games, G.A., "Systematic Safety Assessment in the Mining Industry", The Mining Engineer, March 1980.
- [8] Keenan, C.M., "Historical Documentation of Major Coal-Mine Disasters in the United States Not Classified as Explosions of Gas or Dust, 1846-1962", Bureau of Mines Bulletin 616.
- [9] Kingery, D.S., "Introduction of Mine Ventilating Principles and Practices", Bureau of Mines Bulletin 589.
- [10] Litton, C.P., Hertzberg, M. and Furno, A.C., "The Growth, Structure and Detectability of Fires in Mines and Tunnels", Pittsburgh Research Center, U.S. Bureau of Mines, May 1980.
- [11] Litton, C.D., "Guidelines for Fitting Product-of-Combustion Sensors in Underground Mines", Bureau of Mines I.C. 8919, 1983.
- [12] McDonald, L.B. and Pomroy, W.H., "A Statistical Analysis of Coal Mine Fire Incidents in the United States from 1950 to 1977", Bureau of Mines I.C. 8830.
- [13] "Metal Mine Fire Protection Research", Bureau of Mines I.C. 8752.
- [14] "Mine Waste Disposal Technology", Bureau of Mines I.C. 8857.
- [15] Nelson, H.E. and Shibe, A.J., "A System for Fire Safety Evaluation of Health Care Facilities", National Bureau of Standards, NBSIR 78-1551-1, May 1980.

- [16] Nelson, H.E. and Shibe, A.J., "A System for Fire Safety Evaluation of Multifamily Housing", National Bureau of Standards, NBSIR 82-2562, September 1982.
- [17] Nelson, H.E., Levin, B.M., Shibe, A.J., Groner, N.E., Paulsen, R.L., Alvord, D.M. and Thorne, S.D., "A System for Fire Safety Evaluation for Board and Care Homes", National Bureau of Standards, NBSIR 83-2659, March 1983.
- [18] Nelson, H.E., Shibe, A.J., Levin, B.M. and Thorne, S.D., "Fire Safety Evaluation System for National Park Service Overnight Accommodations", National Bureau of Standards, NBSIR 84-2896, 1984.
- [19] Nelson, H.E. and Shibe, A.J., "The Development of a Fire Evaluation System for Detention and Correctional Occupancies", National Bureau of Standards, NBSIR 84-2976, December 1984.
- [20] Nelson, H.E., "A System Analysis of the Emergency Environment in Buildings", Fire Technology, V. 8, No. 1 (February 1972), 53-66.
- [21] Nelson, H.E., "Directions to Improve Application of System Approach to Fire Protection Requirements for Buildings", Interim Report, July 1977.
- [22] Newman, J.S. and Tewarson, A., "Flame Propagation in Ducts", Factory Mutual Research, Norwood, MA.
- [23] Newman, J.S. and Khan, M.M., "Standard Test Criteria for Evaluation of Underground Fire Detection Systems", Factory Mutual Research, Norwood, MA.
- [24] Newman, J.S., "Performance Evaluation of Mine Fire Detectors", Factory Mutual Research, Norwood, MA.
- [25] Ninteman, P.J., "Spontaneous Oxidation and Combustion of Sulfide Ores in Underground Mines", Bureau of Mines I.C. 8775.
- [26] Richmond, J.K., Price, G.C., Sapko, M.J. and Kawenski, E.M., "Historical Summary of Coal Mine Explosions in the United States, 1959-81", Bureau of Mines I.C. 8909.
- [27] "Underground Metal and Nonmetal Mine Fire Protection", Bureau of Mines I.C. 8865.
- [28] Warner, B.L., "Suppression of Fires on Underground Coal Mine Conveyor Belts", Walter Kidde and Company, Inc., Belleville, NJ.

Figure 1. PRELIMINARY SAFETY PARAMETERS

SAFETY PARAMETER
1. IGNITION SUSCEPTIBILITY OF COAL (VOLATILITY)
2. SELF-HEATING TENDENCY OF COAL
3. GASSINESS (METHANE)
4. GEOLOGICAL STABILITY
5. COMBUSTIBILITY OF EXPOSED SURFACES (ROOF, RIBS, ETC.)
6. COAL DUST CONTROL
7. PRODUCTION METHOD(S)
8. HAULAGE SYSTEM PART A - BELT HAULAGE
PART B - OTHER HAULAGE
9. ELECTRICAL POWER AND EQUIPMENT
10. VENTILATION

SAFETY PARAMETER	
11. AIR COURSE	
12. METHANE CONTROL LEVEL	
13. STOPPING/SEPARATIONS	
14. ESCAPEWAYS	
15. COMMUNICATIONS (BASED ON EMERGENCY FUNCTIONS)	CLARITY
	SPEED
	RECEIPT
16. MONITORING/ DETECTION	
17. FIRE MANAGEMENT FACILITIES	
18. SELF RESCUE EQUIPMENT	
19. EMERGENCY PLANS AND PROCEDURES	
20. SMOKE CONTROL	
21. MINE ACCESS	
22. SPECIAL HAZARDS	

Figure 2(A). SAMPLE DELPHI FORM

FIRE SAFETY PARAMETERS – COAL MINES

SAFETY PARAMETER	PARAMETER VALUES								
1. IGNITION SUSCEPTIBILITY OF COAL (VOLATILITY)	>50%	40-50%	35-40%	30-35%	20-30%	12-20%	<12%		
2. SELF-HEATING TENDENCY OF COAL	SOFTER THAN LIGNITE		LIGNITE	SUB-BITUMINOUS		BITUMINOUS	ANTHRACITE		
3. GASSINESS (METHANE)	SPECIAL PROBLEM (DRAINAGE, ETC. REQUIRED)			SIGNIFICANT (METHANE DETERMINES VENTILATION RATE)			MODERATE (OTHER FACTORS DETERMINE VENTILATION RATE)		LOW OR NONE (INSUFFICIENT METHANE TO PRODUCE EXPLOSIVE MIXTURE)
4. GEOLOGICAL STABILITY	OUTBURSTS				ROOF FALLS				
	FREQUENT		NONE OR UNLIKELY		FREQUENT		OCCASIONAL		NONE OR RARE
5. COMBUSTIBILITY OF EXPOSED SURFACES (ROOF, RIBS, ETC.)	EASILY (LEVEL C)			DIFFICULT (LEVEL B)			HARD (LEVEL A)		
6. COAL DUST CONTROL	NONE OR DEFECTIVE	ROCK DUST WITH ROCK COAL DUST RATIO				WET COAL			
		< 65%	65-70%	70-80%	> 80%				
7. PRODUCTION METHOD(S)	SHOOTING SOLID	CONVENTIONAL			CONTINUOUS MINER			LONGWALL	
		W/ EXPLOSIVES		W/O EXPLOSIVES	DRUM	AUGER	BORER		
8. HAULAGE SYSTEM PART A - BELT HAULAGE	BELT								
	NOT FIRE RETARDANT				FIRE RETARDANT				
	W/O SWITCHES		W/ SWITCHES		W/O SWITCHES		W/ SWITCHES		
	W/O EXTING.	W/ EXTING.	W/O EXTING.	W/ EXTING.	W/O EXTING.	W/ EXTING.	W/O EXTING.	W/ EXTING.	
PART B - OTHER HAULAGE	TRACK			TIRED					
	TROLLEY	DIESEL	BATTERY	DIESEL	TRAILING CABLE		BATTERY		
					DC	AC			
9. ELECTRICAL POWER AND EQUIPMENT	NOT PERMISSIBLE, ETC.				PERMISSIBLE, ETC.				
	W/O GROUND FAULT DETECTION		W/ GROUND FAULT DETECTION		W/O GROUND FAULT DETECTION		W/ GROUND FAULT DETECTION		
	DC	AC	DC	AC	DC	AC	DC	AC	
10. VENTILATION	<100 fpm	100-300 fpm	300-600 fpm	600-900 fpm	900-1200 fpm	1200-1500 fpm	>1500 fpm		

Figure 2(B). SAMPLE DELPHI FORM

SAFETY PARAMETER	PARAMETER VALUES														
11. AIR COURSE	ESCAPEWAY ON RETURN						ESCAPEWAY ON INTAKE								
	INTAKE THROUGH						ADDITIONAL INTAKE			RETURN THROUGH					
	HAULAGEWAYS			SEPARATE ROUTE			THROUGH HAULAGEWAY			HAULAGEWAYS			SEPARATE ROUTE		
12. METHANE CONTROL LEVEL	>3%	2-3%	1-2%	3/4-1%	1/2-3/4%	<1/2%									
13. STOPPING/SEPARATIONS	BRATTICE	WOOD	NONCOMBUSTIBLE WITH FIRE RESISTANCE OF												
			< 20 MIN	20 MIN-1 HR	>1 HR	>1 HR & SEALED									
14. ESCAPEWAYS	SINGLE ROUTE						MULTI-ROUTE								
	ON RETURN			ON INTAKE			ALL ON RETURN			MIXED		ALL ON INTAKE			
15. COMMUNICATIONS (BASED ON EMERGENCY FUNCTIONS)	CLARITY	NONE	SYMBOLIC (BELLS, ETC.)				DEFINITIVE BUT ONE WAY				DEFINITIVE TWO WAY				
	SPEED		DISCRETIONARY		AUTOMATIC		DISCRETIONARY		AUTOMATIC		DISCRETIONARY		AUTOMATIC		
	RECEIPT		DELAY	IMMED.	DELAY	IMMED.	DELAY	IMMED.	DELAY	IMMED.	DELAY	IMMED.	DELAY	IMMED.	
16. MONITORING/ DETECTION	NONE	QUAL. PERS.	MONITORING/DETECTION SYSTEMS HAVING RESPONSE RATIO OF												
			2 OR LESS	1 OR LESS	1/2 OR LESS	1/2 OR LESS AND IS									
							SINGLE THRESHOLD		MULTI THRESHOLD		ANALOG				
17. FIRE MANAGEMENT FACILITIES	NONE	BULK ROCK DUST & FIRE EXT'S		WATER SUPPLY OR EQUIVALENT TO: NUMBER/CAPACITY/PRESSURE OF NOSE STREAMS											
				1/25/25	1/50/50	2/50/50	4/50/50	1/250/50	2/250/50						
18. SELF RESCUE EQUIPMENT	NONE	CO CONVERSION			OXYGEN CONTAINING										
		AT SPECIAL LOCATIONS		W/ EACH MINER	<30 MIN SUPPLY		30-60 MIN SUPPLY		>60 MIN SUPPLY						
					AT SPECIAL LOCATIONS	W/ EACH MINER	AT SPECIAL LOCATIONS	W/ EACH MINER	AT SPECIAL LOCATIONS	W/ EACH MINER					
19. EMERGENCY PLANS AND PROCEDURES	NONE	LAX	STANDARD	ABOVE NORMAL											
20. SMOKE CONTROL	NONE	SMOKE DOORS			OTHER (SPECIFY)										
21. MINE ACCESS	SHAFT	SLOPE	DRIFT												
22. SPECIAL HAZARDS	REMOTE FROM WORK AREAS & ESCAPEWAYS				EXPOSES WORK AREAS OR ESCAPE ROUTES										
	PROTECTED		NOT PROTECTED		PROTECTED		NOT PROTECTED								

**Figure 3. PORTION OF CFR 30/75 NOT INCLUDED
IN THE WORKSHEET**

SUBSET C - ROOF SUPPORT

SUBSET F - ELECTRICAL EQUIPMENT - GENERAL

SUBSET G - TRAILING CABLES

SUBSET H - GROUNDING

SUBSET I - UNDERGROUND HIGH-VOLTAGE DISTRIBUTION

**SUBSET J - UNDERGROUND LOW- AND MEDIUM-VOLTAGE
ALTERNATING CURRENT CIRCUITS**

SUBSET K - TROLLEY WIRES AND TROLLEY FEEDER WIRES

SUBSET N - BLASTING AND EXPLOSIVES

COMPUTE INDIVIDUAL SAFETY EVALUATIONS - USE TABLE 2.

1. Transfer each of the 14 circled safety parameter values on Table 1 to every unshaded block in the line with the corresponding safety parameter in Table 2.
2. Add the eight columns, keeping in mind that any negative numbers deduct.
3. Transfer the resulting values from Table 2 to the blanks marked P in Table 3.

Table 2 - Individual Safety Evaluations

Safety Parameter	Working Place		Intake		Return		Total mine	
	Prevent Explosions	Prev. Other Ignitions	Prevent Explosions	Prev. Other Ignitions	Prevent Explosions	Prev. Other Ignitions	Manage Smoke/Fire	Escape & Rescue
1. Coal Dust Control								
2. Production Method(s)								
3. Haulage System/Belt								
4. Other Haulage								
5. Air Velocity							-1(H)	
6. Methane Control Level								
7. Methane Detection (Mont.)								
8. Stopping/Separations								
9. Escapeways								
10. Communications								
11. Monitoring/Fire Detection								
12. Fire Management Facilities								
13. Emergency Plans and Procedures								
14. Special Hazards								
TOTAL	W =	W =	I =	I =	R =	R =	M =	M =

NOTE H - Multiply the air velocity in the haulage by (-1).

Figure 4. INDIVIDUAL SAFETY EVALUATIONS

Figure 5.

SAFETY PARAMETERS VALUES – WORKING PLACE

TABLE 1

FIRE SAFETY PARAMETERS – COAL MINES

SAFETY PARAMETERS	PARAMETER VALUES												
1. COAL DUST CONTROL	NONE	ROCK DUST TO COAL DUST RATIO											
		< 40	40-65	65-80	>80%								
	-10	-5	0	1	3								
2. PRODUCTION METHODS	SHOOTING SOLID	CONVENTIONAL OR CONTINUOUS MINER		LONGWALL									
	0(-7)A	0		2									
3. BELT HAULAGE	NONE	BELT											
		NOT FIRE RETARDANT			FIRE RETARDANT								
				W/O SWITCHES			W SWITCHES						
	2	-6			-3			W/O EXTING		W. EXTING			
		0		2									
4. OTHER HAULAGE	NONE	NOT PERMISSIBLE (B)		PERMISSIBLE									
		TROLLEY	OTHER	OTHER		BATTERY							
	0(-1)B	-1	0	0	1								
5. AIR VELOCITY (FPM)	< 60	60-100	100-250	>250									
	-10	-2	0	2									
6. METHANE CONTROL LEVEL(%)	> 2.5	>2-≤2.5	>1.5-≤2	>1-≤1.5	3/4-≤1	1/2-≤3/4	≤1/2						
	-10	-5	-3	0	3	7	10						
7. METHANE DETECTION/ MONITORING	NONE	CFR 30		FIXED-POINT METHANE DETECTORS									
		QUAL. / MACHINE MOUNTED	SINGLE THRESHOLD		MULTI-THRESHOLD		ANALOG		ANALOG WITH TRENDING				
			LOCAL ALARM	REMOTE ALARM	LOCAL ALARM	REMOTE ALARM	LOCAL ALARM	REMOTE ALARM	LOCAL ALARM	REMOTE ALARM			
	-10	0		0	1	1	2	1	2	1	2		
8. STOPPING/SEPARATIONS	NONE OR INCOMPLETE	SUBSTANDARD COMBUSTIBLE	SUBSTANDARD NONCOMBUSTIBLE		STANDARD								
	-10	-3	2		4								
9. ESCAPEWAYS	SINGLE ROUTE	MULTI-ROUTE											
		INTAKE/RETURN		INTAKE/HAULAGE			INTAKE/INTAKE						
	-8	0		1			2						
10. COMMUNICATIONS (BASED ON EMERGENCY FUNCTIONS)	NONE	SYMBOLIC (BELLS, ETC.)		DEFINITIVE BUT ONE-WAY		DEFINITIVE TWO-WAY							
						DELAY		IMMED.					
	-10	0		2		4		6					
11. FIRE DETECTION MONITORING	NONE	CFR 30		160°F HEAT DETECTORS AT 10' SPACING		FIXED-POINT PRODUCT OF - COMBUSTION DETECTORS							
		QUAL. / HEAT DETECTORS AT 125' SPACING	SINGLE THRESHOLD		MULTI-THRESHOLD		ANALOG		ANALOG WITH TRENDING				
			LOCAL ALARM	REMOTE ALARM	LOCAL ALARM	REMOTE ALARM	LOCAL ALARM	REMOTE ALARM	LOCAL ALARM	REMOTE ALARM			
	-10	0		1		1	2	1	2	2	3	3	4
12. FIRE MANAGEMENT FACILITIES	NONE	BULK ROCK DUST & FIRE EXTING		WATER SUPPLY OR EQUIVALENT TO NUMBER/ CAPACITY/PRESSURE OF HOSE STREAMS									
				1/25/25	1/50/50	2/50/50	1/250/50						
	-10	3		3	4	5	6						
13. EMERGENCY PLANS AND PROCEDURES	NONE	LAX	STANDARD	ABOVE NORMAL									
		-10	3	5	7								
14. SPECIAL HAZARDS	EXPOSES WORK AREAS OR ESCAPE ROUTES			REMOTE FROM WORK AREAS & ESCAPEWAYS									
	NOT PROTECTED		PROTECTED	NOT PROTECTED		PROTECTED							
		-6		2	-4		2						

NOTE A - Use (-7) when shooting solids, if methane control level in the work place allows more than 1% or coal dust control is less than 65% in the intake or less than 80% in the return.

NOTE B - Use of NOT PERMISSIBLE HAULAGE is limited to mine areas where not permissible equipment is allowed by CFR 30.

Figure 6.

INDIVIDUAL SAFETY EVALUATION – WORKING PLACE

Safety Parameter	Working Place	
	Prevent Ign./Exp.	Prevent Fire Ign.
1. Coal Dust Control		
2. Production Method(s)	0	
3. Haulage System/Belt		2
4. Other Haulage		0
5. Air Velocity	-2	
6. Methane Control Level	3	
7. Methane Detection (Mont.)	0	
8. Stopping/Separations		
9. Escapeways		
10. Communications		
11. Monitoring/Fire Detection		0
12. Fire Management Facilities		
13. Emergency Plans and Procedures		
14. Special Hazards		

Figure 7.
SAFETY PARAMETERS VALUES - INTAKE
TABLE 1

FIRE SAFETY PARAMETERS - COAL MINES

SAFETY PARAMETERS	PARAMETER VALUES												
1. COAL DUST CONTROL	NONE	ROCK DUST TO COAL DUST RATIO											
		< 40	40-65	65-80	>80%								
	-10	-5	0	1	3								
2. PRODUCTION METHODS	SHOOTING SOLID	CONVENTIONAL OR CONTINUOUS MINER			LONGWALL								
	0(-7)A	0			2								
3. BELT HAULAGE	NONE	BELT											
		NOT FIRE RETARDANT			FIRE RETARDANT								
				W/O SWITCHES			W SWITCHES						
	2	-6			-3			W/O EXTING	W. EXTING				
		0		2									
4. OTHER HAULAGE	NONE	NOT PERMISSIBLE (B)			PERMISSIBLE								
		TROLLY	OTHER	OTHER	BATTERY								
	0(-1)B	-1	0	0	1								
5. AIR VELOCITY (FPM)	< 60	60-100	100-250	>250									
	-10	-2	0	2									
6. METHANE CONTROL LEVEL(%)	> 2.5	>2-≤2.5	> 1.5-≤ 2	> 1-≤ 1.5	3/4-≤ 1	1/2-≤ 3/4	≤1/2						
	-10	-5	-3	0	3	7	10						
7. METHANE DETECTION/ MONITORING	NONE	CFR 30			FIXED-POINT METHANE DETECTORS								
		QUAL. / MACHINE PERS. / MOUNTED			SINGLE THRESHOLD		MULTI-THRESHOLD		ANALOG		ANALOG WITH TRENDING		
				LOCAL ALARM	REMOTE ALARM	LOCAL ALARM	REMOTE ALARM	LOCAL ALARM	REMOTE ALARM	LOCAL ALARM	REMOTE ALARM		
	-10	0			0	1	1	2	1	2	1	2	
8. STOPPING/SEPARATIONS	NONE OR INCOMPLETE	SUBSTANDARD COMBUSTIBLE		SUBSTANDARD NONCOMBUSTIBLE		STANDARD							
	-10	-3		2		4							
9. ESCAPEWAYS	SINGLE ROUTE	MULTI-ROUTE											
		INTAKE/RETURN		INTAKE/HAULAGE		INTAKE/INTAKE							
	-8	0		1		2							
10. COMMUNICATIONS (BASED ON EMERGENCY FUNCTIONS)	NONE	SYMBOLIC (BELLS, ETC.)		DEFINITIVE BUT ONE-WAY		DEFINITIVE TWO-WAY							
						DELAY	IMMED.						
	-10	0		2		4				6			
11. FIRE DETECTION MONITORING	NONE	CFR 30		180°F HEAT DETECTORS AT 10' SPACING		FIXED-POINT PRODUCT OF - COMBUSTION DETECTORS							
		QUAL. / HEAT PERS. / DETECTORS AT 125' SPACING				SINGLE THRESHOLD		MULTI-THRESHOLD		ANALOG		ANALOG WITH TRENDING	
					LOCAL ALARM	REMOTE ALARM	LOCAL ALARM	REMOTE ALARM	LOCAL ALARM	REMOTE ALARM	LOCAL ALARM	REMOTE ALARM	
	-10	0		1		1	2	1	2	2	3	3	4
12. FIRE MANAGEMENT FACILITIES	NONE	BULK ROCK DUST & FIRE EXITING		WATER SUPPLY OR EQUIVALENT TO NUMBER/CAPACITY/PRESSURE OF HOSE STREAMS									
				1/25/25	1/50/50	2/50/50	1/250/50						
	-10	3		3	4	5	6						
13. EMERGENCY PLANS AND PROCEDURES	NONE	LAX	STANDARD	ABOVE NORMAL									
		-10	3	5	7								
14. SPECIAL HAZARDS	EXPOSES WORK AREAS OR ESCAPE ROUTES			REMOTE FROM WORK AREAS & ESCAPEWAYS									
	NOT PROTECTED			PROTECTED			NOT PROTECTED			PROTECTED			
	-6			2			-4			2			

NOTE A - Use (-7) when shooting solids, if methane control level in the work place allows more than 1% or coal dust control is less than 65% in the intake or less than 80% in the return.

NOTE B - Use of NOT PERMISSIBLE HAULAGE is limited to mine areas where not permissible equipment is allowed by CFR 30.

Figure 8.

INDIVIDUAL SAFETY EVALUATION – INTAKE

Safety Parameter	Intake	
	Prevent Ign./Exp.	Prevent Fire Ign.
1. Coal Dust Control	1	
2. Production Method(s)		
3. Haulage System/Belt		2
4. Other Haulage	-1	-1
5. Air Velocity		
6. Methane Control Level	3	
7. Methane Detection (Mont.)	0	
8. Stopping/Separations		
9. Escapeways		
10. Communications		
11. Monitoring/Fire Detection		0
12. Fire Management Facilities		
13. Emergency Plans and Procedures		
14. Special Hazards		2

Figure 9.
SAFETY PARAMETERS VALUES - RETURN
TABLE 1

FIRE SAFETY PARAMETERS - COAL MINES

SAFETY PARAMETERS	PARAMETER VALUES										
1. COAL DUST CONTROL	NONE	ROCK DUST TO COAL DUST RATIO									
		< 40	40-65	65-80	>80%						
	-10	-5	0	1	3						
2. PRODUCTION METHODS	SHOOTING SOLID	CONVENTIONAL OR CONTINUOUS MINER			LONGWALL						
	0(-7)A	0			2						
3. BELT HAULAGE	NONE	BELT									
		NOT FIRE RETARDANT				FIRE RETARDANT					
					W/O SWITCHES		W SWITCHES				
	2	-6			-3		W/O EXTING	W. EXTING	0	2	
4. OTHER HAULAGE	NONE	NOT PERMISSIBLE (B)			PERMISSIBLE						
		TROLLEY	OTHER	OTHER	BATTERY						
	0(-1)B	-1	0	0	1						
5. AIR VELOCITY (FPM)	< 60	60-100	100-250	>250							
	-10	-2	0	2							
6. METHANE CONTROL LEVEL(%)	>2.5	>2-≤2.5	>1.5-≤2	>1-≤1.5	3/4-≤1	1/2-≤3/4	≤1/2				
	-10	-5	-3	0	3	7	10				
7. METHANE DETECTION/ MONITORING	NONE	CFR 30			FIXED-POINT METHANE DETECTORS						
		QUAL. / MACHIN PERS. / MOUNTED	SINGLE THRESHOLD		MULTI-THRESHOLD		ANALOG		ANALOG WITH TRENDING		
		LOCAL ALARM	REMOTE ALARM	LOCAL ALARM	REMOTE ALARM	LOCAL ALARM	REMOTE ALARM	LOCAL ALARM	REMOTE ALARM		
	-10	0	0	1	1	2	1	2	1	2	
8. STOPPING/SEPARATIONS	NONE OR INCOMPLETE	SUBSTANDARD COMBUSTIBLE		SUBSTANDARD NONCOMBUSTIBLE		STANDARD					
	-10	-3		2		4					
9. ESCAPEWAYS	SINGLE ROUTE	MULTI-ROUTE									
		INTAKE/RETURN		INTAKE/HAULAGE		INTAKE/INTAKE					
	-8	0		1		2					
10. COMMUNICATIONS (BASED ON EMERGENCY FUNCTIONS)	NONE	SYMBOLIC (BELLS, ETC.)		DEFINITIVE BUT ONE-WAY		DEFINITIVE TWO-WAY					
						DELAY	IMMED.				
	-10	0		2		4		6			
11. FIRE DETECTION MONITORING	NONE	CFR 30		160°F HEAT DETECTORS AT 10' SPACING		FIXED-POINT PRODUCT OF - COMBUSTION DETECTORS					
		QUAL. / PERS. / DETECTORS AT 125' SPACING	SINGLE THRESHOLD		MULTI-THRESHOLD		ANALOG		ANALOG WITH TRENDING		
		LOCAL ALARM	REMOTE ALARM	LOCAL ALARM	REMOTE ALARM	LOCAL ALARM	REMOTE ALARM	LOCAL ALARM	REMOTE ALARM		
	-10	0	1	1	2	1	2	2	3	3	4
12. FIRE MANAGEMENT FACILITIES	NONE	BULK ROCK DUST & FIRE EXTING		WATER SUPPLY OR EQUIVALENT TO NUMBER/CAPACITY/PRESSURE OF HOSE STREAMS							
				1/25/25	1/50/50	2/50/50	1/250/50				
	-10	3		3	4	5	6				
13. EMERGENCY PLANS AND PROCEDURES	NONE	LAX	STANDARD	ABOVE NORMAL							
		-10	3	5	7						
14. SPECIAL HAZARDS	EXPOSES WORK AREAS OR ESCAPE ROUTES			REMOTE FROM WORK AREAS & ESCAPEWAYS							
	NOT PROTECTED		PROTECTED	NOT PROTECTED		PROTECTED					
	-6		2	-4		2					

NOTE A - Use (-7) when shooting solids, if methane control level in the work place allows more than 1% or coal dust control is less than 65% in the intake or less than 80% in the return.

NOTE B - Use of NOT PERMISSIBLE HAULAGE is limited to mine areas where not permissible equipment is allowed by CFR 30.

Figure 10.

INDIVIDUAL SAFETY EVALUATION – RETURN

Safety Parameter	Return	
	Prevent Ign./Exp.	Prevent Fire Ign.
1. Coal Dust Control	3	
2. Production Method(s)		
3. Haulage System/Belt		2
4. Other Haulage	0	0
5. Air Velocity	0	
6. Methane Control Level	-3	
7. Methane Detection (Mont.)	0	
8. Stopping/Separations		
9. Escapeways		
10. Communications		
11. Monitoring/Fire Detection		0
12. Fire Management Facilities		
13. Emergency Plans and Procedures		
14. Special Hazards		2

Figure 11.

SAFETY PARAMETERS VALUES - TOTAL MINE

TABLE 1

FIRE SAFETY PARAMETERS - COAL MINES

SAFETY PARAMETERS	PARAMETER VALUES											
1. COAL DUST CONTROL	NONE	ROCK DUST TO COAL DUST RATIO										
		< 40	40-65	65-80	>80%							
	-10	-5	0	1	3							
2. PRODUCTION METHODS	SHOOTING SOLID	CONVENTIONAL OR CONTINUOUS MINER			LONGWALL							
	0(-7)A	0			2							
3. BELT HAULAGE	NONE	BELT										
		NOT FIRE RETARDANT				FIRE RETARDANT						
					W/O SWITCHES		W SWITCHES					
	2	-6			-3		W/O EXTING	W. EXTING				
				0		2						
4. OTHER HAULAGE	NONE	NOT PERMISSIBLE (B)		PERMISSIBLE								
		TROLLY	OTHER	OTHER	BATTERY							
	0(-1)B	-1	0	0	1							
5. AIR VELOCITY (FPM)	< 60	60-100	100-250	>250								
	-10	-2	0	2								
6. METHANE CONTROL LEVEL(%)	> 2.5	>2-≤2.5	>1.5-≤2	>1-≤1.5	3/4-≤1	1/2-≤3/4	≤1/2					
	-10	-5	-3	0	3	7	10					
7. METHANE DETECTION/ MONITORING	NONE	CFR 30		FIXED-POINT METHANE DETECTORS								
		QUAL. / MACHINE PERS. / MOUNTED	SINGLE THRESHOLD		MULTI-THRESHOLD		ANALOG		ANALOG WITH TRENDING			
			LOCAL ALARM	REMOTE ALARM	LOCAL ALARM	REMOTE ALARM	LOCAL ALARM	REMOTE ALARM	LOCAL ALARM	REMOTE ALARM		
	-10	0	0	1	1	2	1	2	1	2		
8. STOPPING/SEPARATIONS	NONE OR INCOMPLETE	SUBSTANDARD COMBUSTIBLE		SUBSTANDARD NONCOMBUSTIBLE		STANDARD						
	-10	-3		2		4						
9. ESCAPEWAYS	SINGLE ROUTE	MULTI-ROUTE										
		INTAKE/RETURN		INTAKE/HAULAGE		INTAKE/INTAKE						
	-8	0		1		2						
10. COMMUNICATIONS (BASED ON EMERGENCY FUNCTIONS)	NONE	SYMBOLIC (BELLS, ETC.)		DEFINITIVE BUT ONE-WAY		DEFINITIVE TWO-WAY						
						DELAY		IMMED.				
	-10	0		2		4		6				
11. FIRE DETECTION MONITORING	NONE	CFR 30		160°F HEAT DETECTORS AT 10' SPACING		FIXED-POINT PRODUCT OF - COMBUSTION DETECTORS						
		QUAL. / PERS. / DETECTORS AT 125' SPACING	SINGLE THRESHOLD		MULTI-THRESHOLD		ANALOG		ANALOG WITH TRENDING			
			LOCAL ALARM	REMOTE ALARM	LOCAL ALARM	REMOTE ALARM	LOCAL ALARM	REMOTE ALARM	LOCAL ALARM	REMOTE ALARM		
	-10	0		1		1	2	1	2	2	3	3
12. FIRE MANAGEMENT FACILITIES	NONE	BULK ROCK DUST & FIRE EXITING		WATER SUPPLY OR EQUIVALENT TO NUMBER/ CAPACITY/PRESSURE OF HOSE STREAMS								
				1/25/25	1/50/50	2/50/50	1/250/50					
	-10	3		3	4	5	6					
13. EMERGENCY PLANS AND PROCEDURES	NONE	LAX	STANDARD	ABOVE NORMAL								
		-10	3	5	7							
14. SPECIAL HAZARDS	EXPOSES WORK AREAS OR ESCAPE ROUTES			REMOTE FROM WORK AREAS & ESCAPEWAYS								
	NOT PROTECTED		PROTECTED	NOT PROTECTED		PROTECTED						
	-6		2	-4		2						

NOTE A - Use (-7) when shooting solids, if methane control level in the work place allows more than 1% or coal dust control is less than 65% in the intake or less than 80% in the return.

NOTE B - Use of NOT PERMISSIBLE HAULAGE is limited to mine areas where not permissible equipment is allowed by CFR 30.

Figure 12.

INDIVIDUAL SAFETY EVALUATION – TOTAL MINE

Safety Parameter	Total Mine	
	Manage Smoke/Fire	Escape & Rescue
1. Coal Dust Control		
2. Production Method(s)		
3. Haulage System/Belt		
4. Other Haulage		
5. Air Velocity	0	0
6. Methane Control Level		
7. Methane Detection (Mont.)		
8. Stopping/Separations	4	4
9. Escapeways		0
10. Communications	4	4
11. Monitoring/Fire Detection	0	0
12. Fire Management Facilities	4	
13. Emergency Plans and Procedures	5	5
14. Special Hazards		

APPENDIX A

FIRE SAFETY EVALUATION SYSTEM FOR COAL MINES

Introduction

This system divides any coal mine in four parts: total mine, working place, intake, and return. These are defined as follows:

- a. Working Place. Areas of a coal mine inby (toward the working face) of the last open crosscut (a passage at right angles to the main entry to connect it with a parallel entry).
- b. Intake. All portions of the mine receiving air prior to the passage of that air through a working place. Haulage ways are, for the purposes of this system, considered part of the intake section.
- c. Return. All portions of the mine receiving air that has been drawn through a working place.
- d. Total mine. All portions of the mine open to personnel.

The system involves a four step procedure.

- Step 1. Each section is individually appraised using a separate copy of Table 1 per section.
- Step 2. The values assigned in step 1 are transferred to Table 2. Each section is scored separately and a score is developed for the mine as an entity.
- Step 3. The scores developed in step 2 are compared to the scores that would be achieved by a mine in exact compliance with the CFR 30 requirements for the same safety parameters. The CFR 30 equivalent scores are titled "Mandatory Requirements" and shown in Table 3. The comparison is made in Table 4.
- Step 4. An equivalency conclusion is made based on the comparison of the scores developed in step 3 and a separate appraisal of a

list of elements covered in CFR 30 but not included in this system.

Safety Parameter Table (General Discussion)

The safety parameters are a measure of those factors that bear upon or contribute to the safety of those persons who may be in the mine at the time of an explosion or fire.

Each of safety parameters is to be analyzed, and the safety value for each parameter that best describes the condition of the mine is to be identified. Only one value for each of the parameters is to be chosen. If two or more appear to apply, the one with the lowest point value shall be used.

1. Coal Dust Control

Rock dusting is as defined in CFR 30.

- A. NONE. There is no rock dust distributed in the mine section.
- B. ROCK DUST TO COAL DUST RATIO. Where rock dusting is done the value assigned is based on the minimum ratio found.

2. Production Methods

Production methods are limited to the machinery and/or systems for coal removal from the seam. A mine which uses different production methods will analyze each "working place" separately.

3. Belt Haulage

This parameter covers only belt haulage. Other haulage systems are analyzed by Parameter 4 "Other Haulage". The evaluation of the belt haulage system is based on the fire retardancy of the belting material, the presences or absence of sequencing and slippage switches, and the presence or absence of fire extinguishing systems at the belt conveyer drives.

The definitions of fire retardant belting, and the technical descriptions of sequencing switches, slippage switches, and extinguishing systems are as stated in CFR 30.

Some of the headings involve abbreviations as follows:

"W/O SWITCHES" means "without switches"

"W/SWITCHES" means "with switches"

"W/O EXTING" means "without extinguishing systems"

"W/EXTING" means "with extinguishing system"

NONE. There is no belt haulage system in this section of the mine.

4. Other Haulage

This covers all types of mine haulage systems except for belt haulage which is defined in Parameter 3, Belt Haulage. "Permissible" is defined by CFR 30.

NONE. There is no haulage system in this section or no haulage system passes through this section.

5. Air Velocity

The speed of the air movement through the entries or past the working place. In entries, it should be considered in terms of the maximum velocity that extends for any appreciable distance. At the working place, it should be considered as the minimum velocity across the face.

6. Methane Control Level

The operating level of methane concentration allowed in the portion of the mine being evaluated. Evaluation of the method(s) used by the mine to measure the level of methane is covered in Parameter 7, "Methane Detection/Monitoring".

7. Methane Detection/Monitoring

Means by which the miners and mine management ensure that methane concentrations are controlled at required levels. The elements of this parameter are divided between manual means and the use of monitoring devices.

- A. None. Methane test procedures do not meet the minimum requirements of CFR 30.
- B. QUALIFIED PERSON(S) AND MACHINE MOUNTED MONITORS. The minimum requirement of CFR 30 for methane monitoring of the mine spaces and mounting of monitors on production machines are met.
- C. FIXED-POINT METHANE DETECTORS, SINGLE THRESHOLD, LOCAL ALARM. CH₄ detectors set at a single threshold, which will alert the miners only in the section that they are located.
- D. FIXED-POINT METHANE DETECTORS, SINGLE THRESHOLD, REMOTE ALARM. The same requirements as in C except the alarm will also alert a remote mine section above ground.
- E. FIXED-POINT METHANE DETECTORS, MULTI-THRESHOLD, LOCAL ALARM. The same requirements as in C except the sensors which give an alarm signal will give one or more warning signals at threshold level(s) below the alarm signal.
- F. FIXED-POINT METHANE DETECTORS, MULTI-THRESHOLD, REMOTE ALARM. The same requirements as in D except the sensors which given an alarm signal will give one or more warning signals at threshold level(s) below the alarm signal.
- G. ANALOG. An installation of sensors which transmit analog data to a continuously manned location.

H. ANALOG WITH TRENDING. The same requirements as for G plus a surface mounted computer which has the capabilities to recognize trends affecting future changes in CH₄ levels.

8. Stopping/Separations

The dividing walls, partitions, or draping that separates one air course or portion of the mine from another.

A. NONE OR INCOMPLETE. There is no stopping or that the stopping is less than required for "B".

B. SUBSTANDARD COMBUSTIBLE. Stopping consists of wood or other combustible material which is not fire retardant treated. The stopping should be smoke resisting.

C. SUBSTANDARD NONCOMBUSTIBLE. Stopping is smoke resisting and has a fire resistance rating of at least 20 minutes.

D. STANDARD. Stopping constructed of substantial, incombustible material, such as concrete, concrete blocks, cinder blocks or some other incombustible materials. The stopping is smoke resistant and has a fire resistance of at least 1 hour.

9. Escapeways

Continuous route(s) from the section being appraised to the surface meeting CFR 30 requirements for such routes.

A. SINGLE ROUTE. A section has only one separate and distinct travelable escapeway.

B. MULTI-ROUTE. A section has at least two separate and distinct travelable escapeways.

10. Communications

Emergency communication provide warning and other necessary emergency information to persons in the mine.

- A. NONE. There is no communication equipment or communication system available in the mine.
- B. SYMBOLIC. There is an emergency warning system that is limited to either a single or a very limited number of signals that alert the people in the mine that a dangerous condition has occurred but gives little additional knowledge.
- C. DEFINITIVE BUT ONE-WAY. This type of system has more elaborate signals or a voice transmission where additional detail can be given (from a general communications control center to individual mine sections) concerning the type, location, and severity of the hazardous condition.
- D. DEFINITIVE TWO-WAY DELAY. A type of system in which detailed information can be given to the miners and the individual miner (or supervisor) within the mine can communicate to the control center to give or receive information. The Control Center operator separately receives input alarms or other data and manually sends out the initial alarm to the mines.
- E. DEFINITIVE TWO-WAY, IMMEDIATE. The same requirements as in D except that any input alarm from an automatic detection device or a manually operated alarm sending station in the mine will initiate a warning alarm to the miners regardless of the actions of the control center operator.

11. Fire Detection/Monitoring

Means by which the miners and mine management become aware that a fire has occurred or that conditions very likely to initiate a fire are present. The elements of this parameter are divided between manual means and the use of monitoring or detection devices.

- A. NONE. There is no formal patrol meeting the minimum requirements for such patrols of CFR 30. Fire discovery is therefore dependent upon casual observation of the miners. The location of the heat detectors in the belt haulage are not met.
- B. QUALIFIED PERSON(S) AND HEAT DETECTORS AT 125 FEET SPACING. There is no special monitoring equipment. However, a qualified person checks all the prescribed areas and at the frequencies established by CFR 30. The location of the heat detectors in belt haulage are met.
- C. 160 DEGREES HEAT DETECTORS AT 10' SPACING. Heat detectors with a maximum threshold setting of 160 degrees F are spaced at a maximum of 10 feet apart.
- D. FIXED-POINT PRODUCT OF COMBUSTION DETECTORS. SINGLE THRESHOLD, LOCAL ALARM. Combustion detectors (smoke, CO, CO₂) set at single threshold, which alert the miner in the section the detectors are located.
- E. FIXED-POINT PRODUCT OF COMBUSTION DETECTORS. SINGLE THRESHOLD, REMOTE ALARM. The same requirements as D except the alarm will also alert a remote mine section.
- F. FIXED-POINT PRODUCT OF COMBUSTION DETECTORS, MULTITHRESHOLD, LOCAL ALARM. The same requirements as D except the sensor which gives an alarm signal will give one or more warning signals at threshold level(s) below the alarm signal.
- G. FIXED-POINT PRODUCT OF COMBUSTION DETECTORS, MULTITHRESHOLD, REMOTE ALARM. The same requirement as E except the sensor will give one or more warning signals at threshold level(s) below the alarm signal.
- H. ANALOG. An installation of sensors which measure the level of product present and transmit analog data to a continuously manned location.

I. ANALOG WITH TRENDING. The same requirements as for H plus a surface mounted computer which has the compatibility to recognize trends affecting future changes in product of combustion.

12. Fire Management Facilities

A. NONE. Covers any situation where either there are no fire fighting devices or those present fall below the minimum levels for any other element in this parameter.

B. ROCK DUST AND FIRE EXTINGUISHERS. The storage and staging of bags and reserve quantities of rock dust, emergency ceiling materials and portable fire extinguisher distribution, type and condition meet the minimum requirements of CFR 30.

C. WATER SUPPLY OR EQUIVALENT. This requirement includes requirements for B and the requirement for water supply. This parameter however does not include extinguishing equipment on belt haulage that is covered in parameter 3 or the special protection of hazardous areas covered in parameter 14.

The water supply element described in this parameter is based on the number of hose streams, the capacity in gallons per minute of water flow from such streams, and the pressure at which water can be delivered to the fire fighting nozzle. The basis of this standard assumes a combination fog and straight stream nozzle. It also assumes sufficient manpower to handle and advance the hose stream(s).

13. EMERGENCY PLANS AND PROCEDURES

This parameter considers the total capability of both the emergency plans and procedures and the brigade or other force that must execute procedures. The evaluation is based on an overall evaluation of quality.

- A. NONE. This category applies where there is either no emergency plan or those that do exist are distinctly below the minimum prescribed by CFR 30.
- B. LAX. This level applies to those locations that indifferently meet the explicit requirements of CFR 30 but where the quality is "paper compliance" or otherwise of dubious expectation at time of emergency.
- C. STANDARD. Situations complying with CFR 30 in both direct compliance and a reasonable degree of proficiency and readiness to undertake emergency fire actions.
- D. ABOVE NORMAL. Mine where the arrangements and expectations of performance are distinctly above normal.

14. Special Hazards

Special hazards are all of the operations and spaces within the mine that present a fire potential as an exposure to the intake, working section, or return. Hazardous areas normally include storage locations, fuel depots, shops, etc. The criteria are based on whether or not the hazardous areas are remote from work areas and escapeways or whether they are close enough to constitute a direct exposure to the work areas or escape routes. The parameter divides between protected and unprotected hazardous areas. A special hazard is protected if it is contained in a space that is enclosed in fire resistive construction meeting the minimum requirements for such in CFR 30 or approximately one hour fire resistance if not otherwise specified or if the hazard is protected by an automatic extinguishing system of a size and form prescribed in CFR 30 or appropriate to the design of the hazard if no prescription is provided.

Fire Safety Evaluation Worksheet for Coal Mines

Mine Identification _____

Evaluator _____ Date _____

EQUIVALENCY CONCEPT

THIS WORKSHEET GRADES THE RELATIVE LEVEL OF FIRE SAFETY PROVIDED BY SELECTED FIRE SAFETY ELEMENTS THAT CAN OCCUR IN UNDERGROUND COAL MINES. RELATIVE FIRE SAFETY IS DETERMINED BY COMPARING THE SCORES PRODUCED BY A GIVEN SET OF FIRE SAFETY FEATURES AGAINST THE SCORE THAT WOULD BE PRODUCED BY A MINE IN EXACT COMPLIANCE WITH THE FIRE SAFETY RELATED REQUIREMENTS CONTAINED IN THE FOLLOWING PORTIONS OF CFR 30, CHAPTER 1, PART 75 (MANDATORY SAFETY STANDARDS, UNDERGROUND COAL MINES.):

SUBSET D - VENTILATION

SUBSET E - COMBUSTIBLE MATERIAL AND ROCK DUSTING

SUBSET L - FIRE PROTECTION

SUBSET O - HOISTING AND MANTRIPS

SUBSET Q - COMMUNICATIONS

SUBSET R - MISCELLANEOUS (ESCAPEWAYS AND SELF RESCUE)

THERE ARE FIRE SAFETY REQUIREMENTS IN PART 75 NOT COVERED BY THIS WORKSHEET. THEY MUST BE CONSIDERED SEPARATELY TO ASSURE THAT THE MINE HAS THE LEVEL OF FIRE SAFETY PROVIDED BY COMPLIANCE WITH THE SAFETY PROVISIONS OF PART 75. THE FOLLOWING ARE PORTIONS OF PART 75 NOT INCLUDED IN THE WORKSHEET:

SUBSET C - ROOF SUPPORT

SUBSET F - ELECTRICAL EQUIPMENT - GENERAL

SUBSET G - TRAILING CABLES

SUBSET H - GROUNDING

SUBSET I - UNDERGROUND HIGH-VOLTAGE DISTRIBUTION

SUBSET J - UNDERGROUND LOW- AND MEDIUM-VOLTAGE
ALTERNATING CURRENT CIRCUITS

SUBSET K - TROLLEY WIRES AND TROLLEY FEEDER WIRES

SUBSET N - BLASTING AND EXPLOSIVES

First complete Table 1 on page 2. Continue with Table 2 on page 3 and Tables 3 and 4 on page 4. Then return to this page to obtain the Equivalency Conclusions:

Turn to next page

PART E. EQUIVALENCY CONCLUSIONS

Complete Tables 1-4 before doing this part.

1. () All of the checks in Table 4 are in the "yes" column. The level of fire safety is at least equivalent to that prescribed for coal mines.
2. () One or more of the checks in the "no" column. The level of fire safety is not shown by this system to be the equivalent to that prescribed by the CFR 30 for coal mines.

DETERMINE SAFETY PARAMETER VALUES - USE TABLE 1

Select and circle the safety value for each safety parameter in Table 1 that best describes the conditions in the facility. Choose only one value for each of the 14 parameters. If two or more values appear to apply, choose the one with the lowest point value.

Table 1.

FIRE SAFETY PARAMETERS - COAL MINES

SAFETY PARAMETERS	PARAMETER VALUES										
1. COAL DUST CONTROL	NONE	ROCK DUST TO COAL DUST RATIO									
		< 40		40-65		65-80		>80%			
	-10	-5	0	1	3						
2. PRODUCTION METHODS	SHOOTING SOLID	CONVENTIONAL OR CONTINUOUS MINER			LONGWALL						
	0(-7)A	0			2						
3. BELT HAULAGE	NONE	BELT									
		NOT FIRE RETARDANT				FIRE RETARDANT					
					W/O SWITCHES		W SWITCHES				
	2	-6			-3		W/O EXTING	W. EXTING	0	2	
4. OTHER HAULAGE	NONE	NOT PERMISSIBLE (B)			PERMISSIBLE						
		TROLLEY		OTHER	OTHER		BATTERY				
	0(-1)B	-1	0	0	1						
5. AIR VELOCITY (FPM)	< 60	60-100	100-250	>250							
	-10	-2	0	2							
6. METHANE CONTROL LEVEL (%)	> 2.5	>2-≤2.5	>1.5-≤2	> 1-≤1.5	3/4-≤1	1/2-≤3/4	≤1/2				
	-10	-5	-3	0	3	7	10				
7. METHANE DETECTION/MONITORING	NONE	CFR 30		FIXED-POINT METHANE DETECTORS							
		QUAL. PERS. / MACHINE MOUNTED	SINGLE THRESHOLD		MULTI-THRESHOLD		ANALOG		ANALOG WITH TRENDING		
			LOCAL ALARM	REMOTE ALARM	LOCAL ALARM	REMOTE ALARM	LOCAL ALARM	REMOTE ALARM	LOCAL ALARM	REMOTE ALARM	
	-10	0	0	1	1	2	1	2	1	2	
8. STOPPING/SEPARATIONS	NONE OR INCOMPLETE	SUBSTANDARD COMBUSTIBLE	SUBSTANDARD NONCOMBUSTIBLE		STANDARD						
	-10	-3	2		4						
9. ESCAPEWAYS	SINGLE ROUTE	MULTI-ROUTE									
		INTAKE/RETURN		INTAKE/HAULAGE		INTAKE/INTAKE					
-8	0		1		2						
10. COMMUNICATIONS (BASED ON EMERGENCY FUNCTIONS)	NONE	SYMBOLIC (BELLS, ETC.)		DEFINITIVE BUT ONE-WAY		DEFINITIVE TWO-WAY					
						DELAY		IMMED.			
	-10	0		2		4		6			
11. FIRE DETECTION MONITORING	NONE	CFR 30		160°F HEAT DETECTORS AT 10' SPACING		FIXED-POINT PRODUCT OF - COMBUSTION DETECTORS					
		QUAL. PERS. / HEAT DETECTORS AT 125' SPACING	SINGLE THRESHOLD		MULTI-THRESHOLD		ANALOG		ANALOG WITH TRENDING		
			LOCAL ALARM	REMOTE ALARM	LOCAL ALARM	REMOTE ALARM	LOCAL ALARM	REMOTE ALARM	LOCAL ALARM	REMOTE ALARM	
	-10	0	1	1	2	1	2	2	3	3	4
12. FIRE MANAGEMENT FACILITIES	NONE	BULK ROCK DUST & FIRE EXITING		WATER SUPPLY OR EQUIVALENT TO NUMBER/CAPACITY/PRESSURE OF HOSE STREAMS							
				1/25/25		1/50/50		2/50/50		1/250/50	
	-10	3		3		4		5		6	
13. EMERGENCY PLANS AND PROCEDURES	NONE	LAX	STANDARD	ABOVE NORMAL							
		-10	3	5	7						
14. SPECIAL HAZARDS	EXPOSES WORK AREAS OR ESCAPE ROUTES				REMOTE FROM WORK AREAS & ESCAPEWAYS						
	NOT PROTECTED		PROTECTED		NOT PROTECTED		PROTECTED				
	-6		2		-4		2				

NOTE A - Use (-7) when shooting solids, if methane control level in the work place allows more than 1% or coal dust control is less than 65% in the intake or less than 80% in the return.

NOTE B - Use of NOT PERMISSIBLE HAULAGE is limited to mine areas where not permissible equipment is allowed by CFR 30.

COMPUTE INDIVIDUAL SAFETY EVALUATIONS – USE TABLE 2.

1. Transfer each of the 14 circled safety parameter values on Table 1 to every unshaded block in the line with the corresponding safety parameter in Table 2.
2. Add the eight columns, keeping in mind that any negative numbers deduct.
3. Transfer the resulting values from Table 2 to the blanks marked P in Table 4.

Table 2 – Individual Safety Evaluations

Safety Parameter	Working Place		Intake		Return		Total mine	
	Prevent Explosions	Prev. Other Ignitions	Prevent Explosions	Prev. Other Ignitions	Prevent Explosions	Prev. Other Ignitions	Manage Smoke/Fire	Escape & Rescue
1. Coal Dust Control								
2. Production Method(s)								
3. Haulage System/Belt								
4. Other Haulage								
5. Air Velocity							-1(H)	
6. Methane Control Level								
7. Methane Detection (Mont.)								
8. Stopping/Separations								
9. Escapeways								
10. Communications								
11. Monitoring/Fire Detection								
12. Fire Management Facilities								
13. Emergency Plans and Procedures								
14. Special Hazards								
TOTAL	W =	W =	I =	I =	R =	R =	M =	M =

NOTE H – Multiply the air velocity in the haulage by (-1).

Step 3. Determine Mandatory Requirements – Use Table 3

1. Circle the appropriate values in each of the four columns
2. Transfer the circled values from Table 3 to the blanks marked R in Table 4

TABLE 3. MANDATORY SAFETY REQUIREMENTS

Mine Section	Prevent Explosions	Prevent Other Ignitions	Manage Smoke/Fire	Provide Escape and Rescue
Working Place (W)	1	2	X	X
Intake (I)	3	3	X	X
Return (R)	0	4	X	X
Total Mine (M)	X	X	17	13

Step 4. Evaluation Fire Safety Equivalency

1. Perform the indicated subtractions in Table 4.
Enter the differences in the appropriate answer box.
2. For each row check "Yes" if the answer block is ten or greater. Check "No" if the value in the answer block is a negative number

TABLE 4. EQUIVALENCY EVALUATION

				P	R	Yes	No	
Provided "Prevent Explosions"	Minus	Required "Prevent Explosions"	≥ 0	W <input type="checkbox"/> - <input type="checkbox"/> = <input type="checkbox"/>	R <input type="checkbox"/> - <input type="checkbox"/> = <input type="checkbox"/>	I <input type="checkbox"/> - <input type="checkbox"/> = <input type="checkbox"/>		
Provided "Prevent Other Explosions"	Minus	Required "Prevent Other Explosions"	≥ 0	W <input type="checkbox"/> - <input type="checkbox"/> = <input type="checkbox"/>	R <input type="checkbox"/> - <input type="checkbox"/> = <input type="checkbox"/>	I <input type="checkbox"/> - <input type="checkbox"/> = <input type="checkbox"/>		
Provided "Manage Smoke/Fire"	Minus	Required "Manage Smoke/Fire"	≥ 0	M <input type="checkbox"/> - <input type="checkbox"/> = <input type="checkbox"/>				
Provided "Escape and Rescue"	Minus	Required "Escape and Rescue"	≥ 0	M <input type="checkbox"/> - <input type="checkbox"/> = <input type="checkbox"/>				

APPENDIX B
NBS DELPHI PANEL

Delphi Method*

The Delphi technique was developed in the 1950's for the purpose of estimating the probable effects of atomic bombing attacks on the United States. Since then it has been applied to technological forecasting as well as in areas where judgmental information is required. The Delphi technique is basically concerned with the utilization of the combined knowledge of experts to arrive at a consensus opinion where factual information is incomplete.

The NBS exercise followed a process called Policy Delphi. The basic premise of Policy Delphi is that it acts as a precursor to a committee activity. The Policy Delphi is not a substitute for research studies, analyses, or staff work. It is, however, an organized method for correlating views and information pertaining to a specific problem area and for allowing the respondents representing such views and information the opportunity to react to and assess differing viewpoints. Because the respondents are anonymous, fear of potential repercussions or embarrassment is removed and no single individual need commit himself publicly to a particular view until after the alternatives have been put on the table.

Turoff in "The Policy Delphi"*** analyzed committee and Delphi processes. The study points out that a Delphi followed by a committee session provides good results in formulating policies.

The study identified two major areas of problems with large size committees (i.e., communication and psychological). The communication difficulties are attributed to the diverse membership. The major lack of understanding tends to be between the following groups: individuals who are not familiar with many of the new decision aids coming out of operation research and system analyses but who have an intuitive feel for the complexities of the organization, and individuals who have been trained in many of modern management techniques and

*This section was previously printed in Appendix A of "A System for Fire Safety Evaluation for Multifamily Housing, H.E. Nelson and A.J. Shibe, NBSIR 83-2562, September 1982.

***Murray Turoff, "The Design of a Policy Delphi", Technological Forecasting and Social Changes 2, No. 2 (1970).

who are sometimes a little too confident that these approaches can be applied to every problem. The problems associated with the operation of committees that tend to reflect psychological characteristics are:

- The domineering personality or outspoken individual takes over the committee process.
- The unwillingness of individuals to take a position on an issue before all facts are in or before it is known which way the majority is headed.
- The difficulty of publicly contradicting individuals in higher positions.
- The unwillingness to abandon a position once it is publicly taken.
- The fear of bringing up uncertain ideas that may turn out to be idiotic and result in a loss of face.

The above problems may also apply to small size committees, except when the members of the small committee are given sufficient time to consider and explore the issue, and have assurance that the privacy of their respective remarks will be respected outside the committee. Under those conditions a small committee may not have the difficulties which have been identified for the large size committee.

Usually Delphi, whether it is to be conventional or computerized, undergoes four distinct phases. The first phase is characterized by exploration of the subject under discussion, wherein each individual contributes additional information he feels is pertinent to the issue. The second phase involves the process of reaching an understanding of how the group views the issue. If there is significant disagreement among members, the disagreement is explored in the third phase to bring out the underlying reasons for differences and possibly to evaluate them. The last phase, a final evaluation, occurs when all previously gathered information has been initially analyzed and the evaluations have been fed back for consideration.

There are two methods of gaining consensus: conventional and computerized. In the conventional form, a monitor team designs a questionnaire which is sent to a respondent group. After the questionnaire is returned, the monitor team summarizes the results, and based upon the results, develops a revised questionnaire for the respondent group to answer. The respondent group is usually given at least one opportunity to revise its original answers after examining the group response.

The computerized method replaces the monitor group to a large degree with a computer which has been programmed to carry out the compilation of the respondent group results. This process has the advantage of eliminating delays in summarizing each round of Delphi, thereby turning the process into a real-time communication system. However, it does require that the information received from the respondents is in a form that can be fed into a computer and that an algorithm can be provided to analyze the data. The NBS Delphi Group used the conventional four-phase approach in its evaluation process.

Approach Used in Developing Fire Safety Parameters and Their Values

The Delphi Group

Individuals from four different sectors were chosen to participate in the Delphi exercise. The four sections were: (1) Bureau of Mines, (2) Universities, teaching mine related subjects, (3) Factory Mutual, a research organization involved in mine research, and (4) Center for Fire Research. Delphi questionnaires had been distributed to forty-six individuals. Thirty-six completed questionnaires were returned to NBS staff.

Preparing the Questionnaires Forms

Since not all of the factors in the evaluation form apply in the same manner or degree to all portions of a coal mine, nor do they necessarily apply equally to various fire safety methodologies, the mine was divided into three sections: (a) working place, (b) intake, and (c) return.

Similarly, the achievement of fire safety objectives have been divided into five subobjectives: (a) Prevent Explosions (including subexplosion level of methane ignitions), (b) Prevent other Ignitions, (c) Manage smoke Hazards, (d) Manage Fire, and (e) Provide Escape and Rescue.

In view of the three different types of mine sections and the five subobjectives there is a potential of fifteen different fire safety forms. The fire safety form (Table 1) described twenty-two different fire safety parameters with about 140 individual entries. NBS staff decided that it would be a too heavy load for a delphi member to fill out all fifteen fire safety forms. Therefore, each member was asked to complete six versions of the forms. The selections were predetermined by NBS staff to assure all fifteen fire safety areas are sufficiently covered.

Each participant had six different questions to answer with a matrix provided to complete the answer. The questions were phased to include both the mine section and the fire safety objective (e.g., "What is relative impact of each of safety parameters elements on providing escape and rescue from a working section?" or "What is the relative impact of each safety parameter element on prevention of explosions in a mine return section?").

General instructions for completing the questionnaire were:

For each table 1 completed, the Delphi participant is requested to independently search the "matrix" in table 1 and:

- a. Determine the one level of performance in the matrix that is the single most powerful element in achieving the objective (e.g., satisfy the question at the top of the table). To this assign a value of 10 in the "matrix".
- b. Identify those parameters or those parameter levels that neither add nor detract from the objective. These factors are all assigned a value of 0.

- c. Steps one and two above thereby establish a range from 0 to 10. Use this range to set a numerical value (integer) for all other items in the "matrix" that contribute to meeting the objective.
- d. Assign a relative negative value to all items in the "matrix" that are detrimental to meeting the objective. The negative range is not constrained between 0 and -10.
- e. In any case where conditionalities are involved (i.e., the value assigned depends upon the presence or absence of some other factor), the Delphi member is requested to note such conditionality and if possible give values for the worth of the element being measured with and without the presence of the contingent factor.
- f. Add any additional or strike out any excessive safety parameters you feel are unnecessary for a complete evaluation.
- g. Increase the number of parameter subdivisions if the number shown on the form is insufficient. Indicate any that you feel are unnecessary for a complete evaluation.
- h. Complete all entries in the matrix, however, if there are entries where you feel technically incapable of making a judgment, the entry should be marked (x).
- i. Add notes on each form to explain changes or ambiguities.

Analysis of the Questionnaires

1. Forms

The completed forms were checked for completeness and internally consistent logic. Where there were missing data that could not be resolved from form content, the Delphi member involved was contacted to complete the information. Where problems could be corrected by obvious actions, such as correcting the

omission of a negative sign or failure to transfer data from one form to another, the NBS staff completed the obvious omissions.

Many notes were received. All of these have been transferred to a special ledger to be analyzed with the development of the data.

2. Data Analysis

A statistical computer program was used to analyze the data, which included the means, modes, frequency distributions and frequency histograms. Various similarities between the types of the mine sections or fire safety objectives were also analyzed.

Some of the data was widely scattered. For example, the values under "Ignition Susceptibility of Coal for the Prevention of Other (no explosion) Ignitions" for coal having a volatile level of more than 50 percent, two participants graded this factor as a minus 10, one as minus 8, one as minus 9, one as a minus 5, two as minus 3, one as 2, and three felt that the factor has no impact on ignition. Some of the other data was not widely scattered but had multiple modes.

An analysis was made of means, but this was not conclusive for those parameters where a few extreme values dominated a large number of small values.

A detailed analysis of the comments were made to establish effects on the parameters data. Delphi members were contacted by NBS staff to provide these participants with an opportunity to expand upon their initial remarks.

Delphi members were also contacted to discuss the reasons for providing extreme values (either very negative or very positive) in returned forms. Mostly the differences were generated by misinterpretations of the safety parameter functions. The values were then adjusted by the individuals and the process of preparing a consensus safety parameter table began.

3. Safety Parameter Selection for the Redundancy Systems

It is generally recognized that not all safety parameters are of equal importance in proving safety for a particular redundant fire safety system. To identify those parameters which provide significant safety levels for each of the proposed redundancy system, the following method was used. For each of the fifteen redundancy systems a set of three tables was sequentially generated. The first table had all the values of each parameter as assigned by the individual Delphi member. The second table was similar to the first, except numerical values were clustered in six ranks. The rank separations were High (10-8); Medium (7-4); Low (3-0); Negative Low (-1 to -3); Negative Medium (-4 to -7) and Negative High (-8 or less). The third table ranks the safety parameters according to whether they provide high safety values or small safety values. Parameters with high safety values were included in the particular redundancy equation. The low value parameters were excluded from the equations because their ability to affect the total safety of a particular redundancy system was marginal.

4. Delphi Group Status

The Delphi group went through two separate analyses. The group also met several times to consider adjustments or changes to the system suggested by the outside consultants or identified through NBS research. At each meeting the group analyzed the problem and suggested possible improvements to the system.

5. Delphi Members

a. Bureau of Mines

- | | |
|-----------------------|--------------------|
| 1. Bockosh, G.R. | 12. Kissell, F. |
| 2. Cawley, J.C. | 13. Kuchta, J.M. |
| 3. Chilton, J.E. | 14. Lazava, C.P. |
| 4. Schnakenberg, G.H. | 15. Leighten, F.W. |
| 5. Dobroski, H. | 16. Litton, C.D. |
| 6. Fisher, T.J. | 17. McCall, F.F. |
| 7. Fries, E. | 18. Moebes, N.N. |
| 8. Furno, A.L. | 19. Papp, J.F. |
| 9. Jencheck, M.R. | 20. Perry, J.H. |
| 10. Johnson, G. | 21. Sampson, S.J. |
| 11. Kacmar, R.M. | 22. Sacks, H.K. |

b. Center for Fire Research

- | | |
|-------------------|-----------------|
| 1. Braum, E. | 5. Gomberg, A. |
| 2. Bukowski, R.W. | 6. Mallard, G. |
| 3. Cooper, L.Y. | 7. Winger, J. |
| 4. Gann, R. | 8. Walton, W.G. |

c. Academic

Dr. J. Kohler	Penn State University
Dr. D.A. Summers	University of Missouri
Dr. R.H. King	Colorado School of Mines
Prof. R. Greuer	Michigan Technical University
Dr. Y.J. Wang	West Virginia University
Dr. W. Voltz	West Virginia University

d. Other

Dr. J.S. Newman	Factory Mutual Research Corporation
-----------------	-------------------------------------

APPENDIX C
PEER CONSULTING GROUP

Pittsburgh, Pennsylvania

January 17, 1984

Banfield, James C.	MSHA
Kravitz, Jeffrey	MSHA
Miller, Edwin J.	MSHA
O'Rourke, Carl	MSHA
Thomson, Tim	MSHA
Urosek, John E.	MSHA
Welsh, Jeff	Bureau of Mines
Cohen, Ann	Bureau of Mines
Nagy, John	Consultant

Washington, DC
September 5, 1984

Fesak, George M.	MHSA
Elam, Robert	MHSA
Fuller, Gene	MHSA
Oaks, James	MHSA
Welsh, Jeff	Bureau of Mines
Nagy, John	Consultant
Kohler, Jeffrey L., Dr.	Consultant

APPENDIX D

A QUALITATIVE ANALYSIS OF THE INHERENT
FIRE SAFETY/FIRE RISK SYSTEM IN A COAL MINE

Harold E. Nelson

CHAPTER 1 - GENERAL

This is a report of Phase I of the NBS project, Systems Approach to Mine Fire Safety, being conducted under sponsorship of the U.S. Bureau of Mines. The purpose of Phase I was to develop a qualitative description of the inherent fire safety/fire risk system in a coal mine. The approach consisted of the development of an event logic tree to analyze forces and countermeasures involved, and the development of a supporting state transition model to assist in identifying the states of fire development and human response potentially occurring in a mine fire.

An event logic tree and a state transition model have been developed. The development is considered interim as it is expected that additional information will cause improvements and changes during the subsequent phases of the project.

The bulk of the report, Chapters 2 through 12, constructs an event logic tree designed to divide the fire safety methodological factors that determine coal mine fire safety into related constituent parts. Chapter 13 presents a state transition model, designed to consider potential levels of fire development in coal mines.

CHAPTER 2 - EVENT LOGIC TREE APPROACH

The Event Logic Tree approach used in this study follows the general concepts of a reliability tree or a reliability network applied in a qualitative form. The general rules that would apply in a quantitative analysis have been followed. However, the state-of-the-art of data and the potential of acquiring new data is such that it is impractical to expect a truly quantitative tree covering the full breadth undertaken in this exercise. In each case, however, where quantitative data can be developed or used in part, the tree is designed to accept it to whatever degree it may be applicable to an internal tree decision or calculation.

The tree itself is a diagrammatic means of showing the complete event logic system that progressively subdivides the problem (analysis of the existent fire safety/fire risk system in mines) into smaller and smaller elements to the level at which a rational judgement can be made. The tree arrangement assists in pointing out events that must occur simultaneously versus those that can independently control the results. Thereby showing which elements can contribute most effectively to the success of the fire safety system, The tree also inherently expresses choices or tradeoffs that can be involved in this performance. The identification of events and the arrangement of gates in the tree show conditionality and situations where events are mutually exclusive. In designing the tree, the following general protocol was followed:

1. All events were kept consistent in term. In this tree, all events are expressed in terms of success in achieving the fire safety performance of the top event (Event 1.0, Fire Safety Performance).
2. The universe is maintained throughout the tree so that any lateral cut through the tree will describe the identical universe to either the top event or the entirety of the bottom events. This universe is the universe of success (or contribution) to fire safety performance. In addition, the universe of the top event is identical to the collection of all bottom events.

3. At each step, a gate factors the universe of the event above the gate into the events below the gate.
4. Conditionalities are determined and identified in the gates in the tree and in the accompanying definitions.
5. The conditionalities are expressed in unit terms, i.e., if the unit statement is used, a conditional event includes all of its conditionalities such that it can mathematically function as an independent, collective entity.
6. This system is sufficiently dimensionally consistent so that the dimensions feeding into a gate from sub-events are the same and consistent with the event being fed.
7. Each gate can be stated in a mathematical sentence covering all of the involved events including conditionalities.
8. Each event added to the tree adds understanding and potential for the intended use of the tree.

The tree progressively factors the initial or "top" event. In this tree, the top event is entitled, Fire Safety Performance, and is the measured or demanded level of prevention or limitation of harm to persons, property or functional capability. At each step of the factoring, the events necessary to achieve the higher event are deduced and analyzed to determine if success in the higher event is dependent upon simultaneous success in all of the factored events or, conversely, success in any single event. This query determines the type of gate involved.

Traditionally, event logic trees use only two types of gates "AND" and "OR". In this tree, however, the category of types of gates has been further subdivided to show inherent differences "OR" gates. Special symbols have been developed and used to separate the "OR" gates into three separate categories as follows:

- a. Mutually exclusive "OR" gates (either/or, but not both).
- b. Not mutually exclusive "OR" gates (either/or, or both).
- c. Multi-variant relationships (i.e., probability density function), where one event is conditional on both the occurrence and magnitude of the other event.

In addition, this tree includes an approach referred to as a Function Gate. The function gate does not actually subdivide the event in probabilistic type elements, but rather is used to lead to a special branch listing physical or behavioral elements that determine the level of performance of an event. Function gates are always at the termination of a branch of the main tree. Wherever possible, the branches relate fire phenomena or the response of people and material to fire impositions to the events in the tree.

Chapters 3 through 12, and Figures 1 through 14 lay out and analyze the Event Logic Tree.

In Chapters 3 through 12, the tree is analyzed in terms of the definition of events and the functioning of the gates. For each chapter there is a corresponding figure showing the portion of the tree being analyzed. In some chapters there are also corresponding figures showing functional branches related to the chapters. In each case, the analysis is made by following the tree from its top and at each gate moving to the left hand side of the gate. When an end event is reached in this manner, the sequence proceeds to cover all connected events, following the lines of connections, while moving from the left hand side of the page to the right hand side.

CHAPTER 3 - GENERAL EVENT LOGIC TREE (Figure 1)

For ease of handling, the coal mine Event Logic Tree has been divided into a General Event Logic Tree and a series of branches. This chapter covers the general tree. Each terminal event in the general tree is the top event of one of the separately reported branches.

Each event is identified by an arbitrary numbering system that matches the numbering system in the Event Logic Tree, followed by the title of the event. The title matches the wording in the tree. For each event, the principal element is defined and the gate leading from that event to subsequent events described.

1.0 Fire Safety Performance

Fire safety performance is the measured or demanded level of prevention or limitation of selected form(s) of harm to persons, property, or functional capability. The tree can handle all potential forms of harm (either singly or as a synergistic collection). The user of the tree or the authority overseeing its application must, however, declare the specific types of harm under consideration. The event logic tree is so designed that this event is reached only if all routes to it are brought to a common measurement of degree of success in avoidance of harm. In those instances where it is desired to use the tree at a lesser level of sophistication (e.g., probability of avoidance of harm if fire occurs), some portions of the tree rather than its total entity should be used.

Gate 1.0 - The degree of success in meeting fire safety performance objectives is the sum of degree of success in preventing fire initiation plus the degree of success in controlling the impact of those fires that are initiated. This gate is a mutually exclusive "OR" gate. In any specific instant, success may be achieved by preventing fire or controlling it, but not by both.

2.1 Prevention of a Fire Initiation

Fire initiation is the start of the destructive endangering process of burning. The actual onset of fire initiation may be defined differently by different users of the tree. It is considered legitimate to define fire initiation by any of the critical events listed in Chapter 13 as a transition from State 0 to another state. It is essential, however, that the user of the tree declare his working definition of the onset of fire initiation and that this definition be held constant throughout that use of the tree.

Gate 2.1 - The degree of success in prevention of fire initiation is the sum of the degree to which all potential fuel is managed to keep it in an unignitable condition and the degree to which ignition sources are kept from any fuel that is in an ignitable condition.

3.1 Manage Fuel Ignitability

To be ignitable, a material must be combustible (i.e., a fuel) and be in a condition where the presence of ignition energy in contact with the fuel or volatilized effluent from the fuel bed will result in fire initiation.

Gate 3.1 - The degree of success in managing fuel ignitability is the sum of the degree that fuel is made unavailable to potential ignition energy sources plus the degree to which that available is prevented from reaching a susceptible condition.

4.1 Control Fuel Availability

A material is considered an available fuel if it is combustible and its location and character are such that it may exist in, or be brought to an ignitable condition by either normal or emergency environments.

Control fuel availability is the top event of a separate branch. This branch is covered in Chapter 4.

4.2 Control Fuel Susceptibility

To be susceptible a fuel must be available. An available fuel is susceptible to ignition if the inherent or situation induced conditions bring the fuel to a state where the presence of an ignition source can cause the onset of fire. Since ignition susceptibility applies only to those fuels that are available, all considerations of degree of success in this event are conditional on the degree of failure of Event 4.1, Control Fuel Availability.

Control fuel susceptibility is the top event in the branch of the tree covered in Chapter 5.

3.2 Limit Igniters

An igniter is any energy source sufficient to raise the temperature of an ignitable fuel (see Event 3.1) to the transition from a non-burning state to fire initiation (in accordance with the definition of fire initiation used in the particular application of the tree).

Limit Igniters is a conditional event. Success in this event contributes to the overall success of the tree only to the extent that such igniters relate to fuels that are in an ignitable condition (i.e., degree of failure of Event 3.1, Manage Fuel Ignitability).

Limit Igniters is the top event of the branch of the tree covered in Chapter 6.

12.1 Control Impact

Control impact is the top event in one of the two major subdivisions on the tree. (Prevention of Fire Initiation is the other major subdivision.)

All aspects of the tree relating to any state of burning, except State 0, Non-Burning (see Chapter 13), are covered under this event.

Impact is the extent and degree of harm that results if fire is initiated. Harm is measured in the same terms as the harm element of Event 1.0, Fire

Safety Performance. Control impact is a conditional event dependent on the failure of Event 2.1, Prevention of Fire Initiation.

Gate 12.1 - The degree of success in controlling the impact of any fire that occurs is the sum of the degree that the fire threat is controlled plus the degree that the exposed (persons, property, or functional capability) are protected against the residual (uncontrolled amount of) threat.

13.1 Threat Control

Threat is the potentially harmful effects of fire as measured at any given place or moment in the fire. Threat is the combined harmful potential of all forms of change that are induced by fire, its effects, or the impact of fire control measures. Included are the combustion zone itself, smoke and heated or toxic gases, reduction in oxygen, structural collapses and extinguishment byproducts.

Gate 13.1 - The degree of success in threat control is the degree of concurrent control of the threat produced by the fire energy, the threat imposed by the mass products produced by the fire by itself or in combination with extinguishing efforts, and the threat from other fire induced conditions such as, oxygen depletion or roof collapse.

14.1 Control Threat Produced by Fire Energy

The fire energy threat is the fire (combustion reaction) itself and all forms of threat produced by that combustion and fire caused responses to it.

The degree of success in controlling the threat produced by fire energy is the sum of the degree of success in limiting the inherent potentials (size and level of energy) plus the degree of success of intervention efforts to stop or limit the development of that potential.

15.1 Limit Inherent Potential

The inherent potential of a fire is defined as the extent of spread of the combustion process and the resultant energy release, given the lack of successful intervention efforts to halt, limit, or terminate such potential.

Limit Inherent Potential is the top event of the branch covered in Chapter 7.

15.2 Control by Intervention

Intervention is the application of any fixed or "time-of-fire" feature or act that causes a termination, slowing, or other reduction in the potential fire energy threat. Intervention impacts on the outcome only to the degree that it reduces a threat that is not limited or controlled by the Limit Inherent Potential Branch.

Intervention is the top event in the branch of the tree covered in Chapter 8.

14.2 Control Mass Products Threat

Mass products are defined as the various chemical species and particulate products generated by the combustion process or by efforts to extinguish or control that process. Mass products also include any air or other gases entrained into the flow of fire generated products. Mass products include, but are not limited to, those fire products usually referred to as smoke and toxic gases.

Control Mass Products Threat is the top event in the branch of the tree covered in Chapter 9.

14.3 Control Other Fire Induced Threats

Other Fire Induced Threats is an open-ended term covering both the identified and potential, yet unidentified threats not covered under the definitions of Fire Energy or Mass Products. This includes but is not limited to the threats

resulting from fire induced depletion of oxygen, roof or structural collapse, and pressure fronts produced by a fire induced explosion.

Control of Other Fire Induced Threats is the top event in the branch of the tree covered in Chapter 10.

23.1 Protect "Exposed"

Exposed is defined as the persons, property, or capabilities under consideration. Any specific definition is appropriate but it must be identical to that which is the objective of Event 1.0, Fire Safety Performance,

Gate 23.1 - The degree of success in protecting the "exposed" is the sum of the degree of success in limiting the quantity of "exposed" plus the degree to which the number of exposed persons or amount of property, or capacity present is safeguarded from the degree of threat not controlled by the events covered under Event 13.1, Threat Control.

24.1 Limit or Exclude "Exposed"

The definition of "Exposed" is as stated in Event 23.1, Protect "Exposed".

Limit or Exclude "Exposed" is the top event in the branch of the tree covered in Chapter 11.

24.2 Safeguard "Exposed" from Given Threat

The definition of "Exposed" is as stated in Event 23.1, Protect "Exposed". The degree of "exposed" consists of that which is not excluded or limited by Event 24.1, Limit or Exclude "Exposed". The threat of concern is the residual resulting from the degree of failure of Event 13.1, Threat Control.

Safeguard "Exposed" from Given Threat is the top event in the branch of the tree covered in Chapter 12.

CHAPTER 4. - CONTROL FUEL AVAILABILITY BRANCH (Figure 2)

4.1 Control Fuel Availability

A material is an available fuel if it is combustible and its location and character are such that it may exist in or be brought to an ignitable condition by either normal or emergency environments.

Gate 4.1 - The degree of success in controlling fuel availability is the degree to which fuels can be kept from the mine, plus the degree that fuel in the mine is removed, or is kept in a state or condition that makes it more difficult for environmental conditions to bring it to an ignition susceptible state.

5.1 Control Entry

Entry of fuel applies to any combustible material brought into the mine for construction, maintenance, comfort, production, or other reasons. The degree of success is the degree that such fuel is limited either by prohibition or control of the combustibility of the materials actually used.

This is an End Event in the event logic tree as drawn. The user of the tree may desire, at his own discretion, to extend this or any other End Event further into its constituent element if his needs so dictate.

5.2 Remove

Removal of fuel covers any action that takes the fuel (gas, liquid, or solid) from the mine.

Gate 5.2 - The degree of success of removal of fuel is the degree that fuel is taken from the mine by any means that transports it out of the environment.

6.1 Exhaust

Removal of fuel by exhaust is the removal of gases or airborne fuels from the excavate portions of the mine by exhaust fan or other pressure induced differentials.

6.2 De-gas

De-gasing is the removal of methane or other entrapped gases from the indigenous unmined coal mass prior to mining or excavation operations.

6.3 Clean

Removal by cleaning is the transport of solid or liquid materials that are no longer performing operational or other functions out of the mine. This includes both materials brought into the mines and the clean-up of any spillage of product coal that occurs from the mine production, haulage or storage of coal.

6.4 Other

Other is recognition that there can be removal arrangements other than those defined under Exhaust, De-gas, and Clean.

Events 6.1, 6.2, 6.3, and 6.4 are End Events in the Event Logic Tree as drawn.

5.3 Control of Availability of Fuel Present

The fuel present is all of that indigenous and non-indigenous fuel that is present in the mine at any instance. It includes both the mined and unmined coal; entrapped or liberated methane or other material; and all construction, operational, or other fuels that have been brought into the mine. Availability is the sum of the physical factors (e.g., particle size, location, encasements) that determine the degree of exposure of the fuel to the energy environment.

Gate 5.3 - The degree of success in Control of Availability of Fuel Present is the sum of the degree of success in preventing or limiting increases in factors that make fuel more available plus the degree to which fuels can be made less available to influence by energy environments.

6.5 Limit Increases in Availability of the Fuel

Increases in availability are those actions or processes that cause a fuel to become more available to influence by energy environments. The energy environments include all conditions (normal and abnormal) that bring radiated, convected, or conducted energy to a fuel. The source of the energy may be from any heat producing condition. Typical examples of design or controllable activities that influence any increase in the level of availability include:

- A. The rate and mode of production at the working face(s).
- B. The type and rate of product haulage including haulage system design elements that influence the amount of spillage or dust produced.
- C. The condition of hydraulic systems in terms of the potential of spray or other release of combustible fluids from the contained system.

This is an End Event in the Event Logic Tree as drawn.

6.6 Reduction of the Availability of a Fuel (i.e., Control Fuel Exposure)

The reduction of the availability of a fuel is any act or arrangement that causes that fuel to be less exposed to influence by those energy environments that can result in ignition. Most typically this involves either the containment or covering of a fuel to barricade it from the fire inducing environmental conditions. Typical examples include:

- A. Use of safety cans or other suitable containers for flammable liquids.
- B. Sprayed concrete or other coating of the ribs or coal roof in portions of a mine.

This is an End Event in the Event Logic Tree as drawn.

CHAPTER 5 - CONTROL FUEL SUSCEPTIBILITY BRANCH (Figure 3)

4.2 Control Fuel Susceptibility

To be susceptible a fuel must be available. An available fuel is susceptible to ignition if the inherent or situation induced conditions cause a fuel to be in a state where the presence or an ignition source can cause the onset of fire. Since ignition susceptibility applies only to those fuels that are available, all considerations of degree of success in this event are conditional on the degree of failure of Event 4.1, Control Fuel Availability.

Gate 4.2 - The degree of success in controlling fuel susceptibility is the sum of the degree of success in maintaining environmental conditions outside the combustible limits of the fuel plus the degree of success in controlling the response to incident energy of those fuels in environments potentially within the combustible limits of the fuel involved.

5.4 Maintain Environment Outside Combustible Limits of Fuel

A fuel is outside of the combustion limits of that fuel if the ratio of fuel to oxidizer (air or oxygen) is such that combustion will not take place. For gases, aerosols, or dusts this applies to the mixture of any of these in the air. To solid materials such as piles of coal or gob this applies to the interface between the solid material and the surrounding environment.

Gate 5.4 - The degree of success in maintaining environments outside the combustion limits of the fuel is the sum of degree of success in maintaining environments that are fuel rich plus the degree of success in maintaining environments that are fuel lean.

6.7 Develop Fuel Rich Environment

A fuel rich environment is one in which either the concentration of fuel or the shortage of air or other oxidizers is such that combustion cannot take place.

Typical applications of this approach include:

- A. The exclusion or removal of oxygen by the use of an inert gas or other inert material (rock dust, etc.) to encase or surround a condition (such as welding) where high temperatures and fuels might necessarily be in intimate proximity to each other.
- B. The reduction of oxygen through absorption into the environment as occurs when gob or other abandoned areas are sealed.
- C. The prevention of the mechanical dispersion of a combustible material from vibration and from high pressure (spray) leaks from hydraulic systems and as the secondary result of a methane ignition.

This is an End Event in the Event Logic Tree as drawn.

6.8 Develop Fuel Lean Environment

A fuel lean environment is one in which the amount of fuel is insufficient to undergo the combustion process. The typical example of a fuel lean environment exists in the properly designed mine exhaust stream that maintains methane below its explosive limits.

This is an End Event in the Event Logic Tree as drawn.

5.5 Control Temperature Dependent Susceptibility

Temperature dependent susceptibility factors are those that control the level of temperature at which a fuel (not maintained outside of combustible limits by Event 5.4) volatilizes sufficiently to produce a combustible mixture susceptible to ignition.

Gate 5.5 - The degree of success in controlling the temperature dependent factors is a multi-variant relationship between the level of control of the critical volatilization temperature of the fuel and the degree of control of the temperature rise in the fuel.

6.9 Manage Critical Temperature of Fuel

The critical temperature of a fuel is that surface temperature at which the rate of volatilization of combustible matter is such that the entry of an ignition energy can initiate fire as defined in Event 2.1, Prevention of Fire Initiation. This is normally accomplished by techniques such as:

- A. Use of noncombustible material (infinitely high critical temperatures).
- B. Selection of materials that inherently have higher critical temperatures.
- C. Treatment of material to increase the critical temperature of a material.

This is an End Event in the Event Logic Tree as drawn.

6.10 Maintain Surface Temperature Below Critical Level

Given the degree of control of critical temperature, the susceptibility of a fuel is determined by the degree to which such fuel can be maintained below that critical temperature. For each fuel there is potentially a different critical surface temperature. Some fuels have critical temperatures below ambient temperatures. For flammable liquids the critical temperature is traditionally described in terms of flash point.

Gate 6.10 - The degree of success in maintaining surface temperatures below the critical level is the degree to which there is concurrent success in cooling any materials that have critical temperatures at or below ambient temperature to a level lower than their critical temperature, and the degree of success in preventing critical temperature rises in those materials that have critical temperatures higher than ambient temperature.

7.1 Reduce Surface Temperature of Fuel Below Critical Temperature

Reduction of surface temperature below the critical temperature includes any action or arrangement that either reduces the surface temperature directly as by surface cooling or which reduces the overall ambient environment below that

which is critical (e.g., ventilation cooling of a space to prevent self-heating)

This is an End Event in the Event Logic Tree as drawn.

7.2 Prevent Temperature Rise of Fuel

For those fuels where the critical temperature is above ambient, **susceptibility** to ignition can be controlled by preventing rise in the **surface temperature** of such material.

Gate 7.2 - The degree of success in preventing the **surface temperature** rise is the sum of degree of success in preventing the impact of incident energy upon the fuel, plus the degree of control of response of that fuel to incident energy.

8.1 Interpose Energy Transfer Barrier Between Energy Source and Fuel

Barriers may be total or partially effective in preventing the **transfer** of heat energy, depending on their position and energy response. Such barriers, may be on the heat source, on the target, or at some intervening point **between**.

This is an End Event in the Event Logic Tree as drawn.

8.2 Control Response to Incident Energy

The characteristic response to incident energy can be controlled or predicted in terms of the characteristics of the incident energy source and the responding characteristics of the fuel.

Gate 8.2 - The degree of success in controlling the response to incident energy is a multi-variant relationship between the incident energy and the resistance to incident energy impact of the individual item.

9.1 Incident Energy

Incident energy is that energy which reaches the fuel surface from all energy producing sources.

This is an End Event in the Event Logic Tree as drawn, however, Functional Branch A outlines the basic physical elements that determine the level of incident energy.

Functional Branch A - Incident Energy (Figure 11)

The incident energy impact on a target fuel is the sum of the energy radiated to that target plus the energy conducted to that target plus the energy convected to that target.

A-1 Radiation - Radiation is the transfer of heat from one body to another by means of wave motion through space. The amount of energy radiated at the target is a function of the absolute temperature of the radiator (A-4), the emissivity (i.e., radiant efficiency) (A-5), and the configuration or viewing factor relationship between the fire source and the target (A-6). The amount of radiation varies with the fourth power of the absolute temperature and directly with emissivity and configuration factor. The emissivity or radiation efficiency of many solid materials varies with the temperature of that material. Configuration factor is a spherical geometry relationship that depends upon the size of the radiation source (length and width), the distance between the radiation source and the target, and the angle between the face of the radiator and the line site to the target.

A-2 Conducted Energy - Conduction is the transfer of heat from one part of a body to another part of the same body or from one body to another in physical contact with it.

A. Conduction through a body (A-7) is a function of the temperature differential between the exposed and the unexposed faces of the heat conducting body (A-8), the

thickness of the conducting body (A-9), the thermal inertia (KpC) of the conducting body (A-10) and the thermal conductivity (K) of the conducting body (A-11).

B. Conduction between physically contacting bodies (A-12) is a function of the temperature differential between the bodies (A-13) and the effective heat transfer coefficient involved (A-14).

A-3 Convected Energy - Convection is the transfer of heat from one point to another within a fluid (gas or liquid) by movement of heated portions of the fluid or by the mixing of one portion of the fluid with another. The convected energy is a function of the temperature differential and mass of the heated portion of the fluid (A-15), the relative position of the source of the heated gas and the target (A-16), and the cooling of the gases in transit (A-17). The cooling of the gases in transit are in turn a function of any energy lost from the gases through radiation (A-18) through conduction to other portions of the fluid mass through dilution and mixing (A-19) and the conduction of energy due to contact between the fluid and any other body (surface) (A-20).

9.2 Resistance to Energy Impact

The resistance to energy impact is the characteristic response of a material to the impact of incident energy on it. This response is in terms of the speed at which surface conditions progress toward equilibrium with the incident energy. The slower the surface temperature rise the more resistance to energy impact.

This is an End Event in the Event Logic Tree, however, Functional Branch B outlines the basic physical elements that control the response of a material to incident energy.

Functional Branch B - Resistance to Energy Impact (Figure 11)

The resistance to energy impact is a combined function of the thickness of the material (B-1), the reflectivity of its surface (B-2), and its thermal inertia

(B-3). Thermal inertia is a measurement of the capability of the target material to receive heat energy and absorb or distribute it within. Thermal inertia is a function of the thermal conductivity (B-4), the density (B-5), and the specific heat (B-6) of the material. Some of these factors vary through the course of exposure with temperature change. The target surfaces of low thermal inertia materials quickly come to equilibrium with incident energy (heat up quickly). Conversely, the target surfaces of high thermal inertia materials tend to resist coming to equilibrium by dissipating the energy through the mass of the material. As materials become thicker, relative importance of thickness decreases. For very thin materials (cloth, thin plywood, coal dust, etc.) thickness is a critical element. For thicker materials such as heavy timbers or the undisturbed coal mass, the thickness is infinite as far as thermal energy transfer is concerned.

CHAPTER 6 - LIMIT IGNITERS BRANCH (Figure 4)

3.2 Limit Igniters

An igniter is any energy source sufficient to raise the temperature of an ignitable fuel (see Event 3.1) to the transition from a non-burning state to fire initiation in accordance with the definition of fire initiation used in the particular application of the tree.

Gate 3.2 - The degree of success in limiting igniters is the degree to which there is concurrent control of both pilot ignition sources and self (auto) ignition potentials. The contribution of the degree of success in limiting igniter to the overall Event Logic Tree success is conditional on the degree of failure of Event 3.1 (i.e., limiting the availability of ignition susceptible fuels). By definition, the simultaneous failure of both Event 3.1 and 3.2 (i.e., the joining of a susceptible, ignitable fuel and an igniter) is failure of Event 2.1, Prevention of Fire Initiation.

4.3 Control "Pilot" Ignition Potential

Ignition pilots are energy sources external to the potential fuel that can start the combustion reaction necessary for fire initiation as specified by Event 2.1, Prevention of Fire Initiation, when exposed to a fuel in an ignitable condition as defined by Event 3.1.

Gate 4.3 - The degree of success controlling pilot ignition potential is the sum of the degree to which pilot ignition sources are excluded from areas of fuel ignitability plus the degree to which those sources that are not excluded are otherwise controlled to prevent the imposition of ignition level energy on the ignitable fuels.

5.6 Prohibit, Limit, Exclude

The objective of this event is to prevent the intersection of a pilot ignition source with an ignitable fuel. The extensive degree of ignitable fuel and the frequency and variety of pilot ignition sources inherent in coal mines tends to

limit the extent of success of this event. However, the degree that pilot ignition sources such as open flames, arcing equipment, and hot bodies can be kept out of the mine, add to the success of this event. Success is also achieved in cases where the location of pilot ignition source, such as welding equipment, is controlled to separate it from ignitable fuels.

This is an End Event in the Event Logic Tree as drawn.

5.7 Other Protection

Other protection includes any devices or arrangements that preclude a potential pilot ignition source from causing ignition including: reduction of the level of energy of a device below that necessary to cause ignition of the susceptible fuel; inherently safe electrical equipment; equipment so designed that if a combustible mixture reaches the point where the energy level is sufficient for ignition potential, propagation will take place (e.g., explosion proof equipment and the flame arrestors in methane detection lamps); or other pilot igniter protection arrangements.

This is an End Event in the Event Logic Tree as drawn.

4.4 Control Self (auto) Ignition Potential

Auto ignition is defined as ignition that occurs in the absence of pilot igniters. In this case ignition results from raising the temperature of the fuel itself to the point where its own surface temperature exceeds the energy level necessary to ignite it or the material volatilized from it.

Gate 4.4 - The degree of success in controlling auto ignition as a contribution to the overall degree of success in limiting igniters is that degree to which auto ignition is prevented when there are no pilot igniters (i.e., when Event 4.3 is also successful). Within this constraint, the degree of success is the degree of success in concurrently preventing both internally induced (self) heating and externally induced heating.

5.8 Internally Induced Heating Control

Internally induced heating is defined as that heating in which the temperature of the heated material is higher than the surrounding ambient atmosphere. Such heating is normally a function of the inherent self heating characteristics of the material (e.g., coal and its entrained volatile products); the total mass, the amount of radiant surface to dissipate heat (in terms of a surface to mass ratio), the temperature of the mass, and the temperature of the surrounding environment.

This is an End Event in the Event Logic Tree as drawn.

5.9 Externally Induced Heating Control

Externally induced heating is defined as heating of a mass from an external environment or a heat source in the external environment at a higher temperature than target fuel. The factors controlling this event are identical to those controlling the development of Event 5.5, except that the critical temperature of concern is critical ignition temperature rather than critical volatilization temperature.

This is an End Event in the Event Logic Tree as drawn.

CHAPTER 7 - LIMIT INHERENT POTENTIAL BRANCH (Figure 5)

This branch of the tree relates to the inherent or unencumbered energy production potential of an ignited fuel. It does not treat those actions or arrangements such as suppression or confinement that can mitigate this potential, nor does it treat the resulting threat that can occur from smoke gases and other mass products produced, or separate threats such as oxygen depletion or mine collapse. Each of these are covered in separate chapters.

15.1 Limit Inherent Potential

The inherent potential of a fire is defined as the extent of spread of the combustion process and the resultant energy release if there are no successful installed or emergency instituted devices or efforts to halt, limit, or terminate it.

Gate 15.1 - The degree of success in limiting the energy potential is the degree of success in concurrent control of the extent of the burning area, the energy characteristics of the burning area, and the duration of burning.

16.1 Control Extent of Burning Area

The extent of burning area is defined as the surface area of all materials undergoing destructive oxidation at any time plus all portions of the flame body that are undergoing energy generating combustion reactions.

Gate 16.1 - The degree of success in controlling the extent of the burning area is the degree to which there is concurrent control of both the extent of flame spread across combustible surfaces and the control of the involvement of additional fuels through other means.

17.1 Control Surface Flame Spread

Surface flame spread is defined as the progressive involvement across the surface of a continuous or nearly continuous combustible face from a fire source emitting from or in intimate contact with the surface.

Gate 17.1 - The degree of success in controlling the surface flame spread is the sum of the degree of success that the response of the materials involved can be controlled to obstruct or retard flame spread plus the degree to which the external environmental factors can be controlled to prevent energy reinforcement of flame spread.

18.1 Control Material

Control of a material relates to both the inherent flame spread characteristics of the material and the response of that material to incident energy from its own flame or from other sources.

Gate 18.1 - The degree of success in controlling surface flame spread through control of materials is the sum of the degree that the chemical burning characteristics of the material are controlled and the degree to which the thermal response of a material is controlled.

19.1 Control Chemical Response

Chemical response is the subjectivity to pyrolysis of the constituent molecules volatilized from the base material or reacted in place in the material matrix. Methods of controlling this process include the use of materials that are either non-combustible or inherently have low combustibility (e.g., use of masonry block or transite material to construct shop partitions or the clearing of the overhead to bare rock to eliminate the combustibility of the ceiling). Alternatively chemical control of the response of an inherently combustible material can be enhanced by fire retardant treatment (e.g., fire retardant treated wood or fire retardant treated brattice).

This is an End Event in the Event Logic Tree as drawn.

19.2 Control Temperature Rise of Unignited Portions of Surface

The unignited portions of the surface must be raised to a temperature sufficient to evolve an ignitable concentration of volatilized combustion

products from the uninvolved surface in front of the flame front. The energy to do this may come from the advancing fire on the adjacent surfaces or from any other source.

Gate 19.2 - The degree of success in controlling the temperature rise of unignited portions of a surface is the sum of the degree of success in interposing barriers to energy transfer between the energy source and the unignited portion of the surface plus the degree of success in controlling the response of the surface to the incident energy that strikes it.

20.1 Obstruct Energy Transfer to Surface

The energy transfer to the surface of a combustible material is limited to that energy that actually reaches and is transferred to that material.

Gate 20.1 - The degree of success in obstructing energy transfer is a multi-variant functional relationship between the energy exposure and the effectiveness of the obstruction to the transfer of such exposure to the unignited surfaces.

21.1 Energy Exposure

Energy exposure includes all forms of energy that are present in a form and level that has a potential of impacting on a target material.

This is an End Event in the Event Logic Tree as drawn, however, Functional Branch A, as described in Chapter 5, covers the factors that control the level of energy exposure and the potential incident energy where no obstructions are present.

21.2 Effectiveness of Obstructions to Energy Exposure

Obstructions to energy exposure include any type of barrier or energy absorbing media between the energy producing source and the target surface; insulation or barriers applied to the target; and cooling systems (e.g., water sprays) that

remove energy reaching the target before it can be transferred to the target surface.

This is the End Event in the Event Logic Tree as drawn.

20.2 Control Response to Incident Energy

The response of the material to incident energy (relative to surface flame spread) is the potential of the surface zone of that material to rise in temperature given the degree of energy impact of the surface (i.e., degree of failure of Event 20.1).

Gate 20.2 - The control of response to incident energy is a multi-linear function of the relationship between the incident energy actually impacting on the target surface and the resistance of that surface to such energy impact.

21.3 Incident Energy

The incident energy striking the surface zone is all of the energy not obstructed in accordance with Gate 20.1.

This is an End Event in the Event Logic Tree as drawn.

21.4 Resistance to Energy Impact

The resistance to energy impact is the capability of the target surface to receive incident energy and distribute it within or through the target material in such a manner as to retard the tendency of that material to rise in surface temperature towards equilibrium with the incident energy.

This is an End Event in the Event Logic Tree as drawn, however, the functional elements controlling the resistance to energy impact are those described in Functional Branch B previously discussed under Chapter 5.

18.2 Control Level of Energy Exposure to Unignited Portions of Surface

Event 18.1 governs the response of a surface to an exposing energy environment relative to fire initiation. This event is designed to govern the response of a surface to an exposing energy environment that occurs after fire initiation. In all other aspects, the two events are identical.

Gate 18.2 - The degree of success in controlling the energy exposure is the degree that there is concurrent control of the total energy developed by the exposure produced by the involved portions of the surface along with control of any other exposure produced from other aspects of the general environment.

19.3 Control Exposure from Involved Portions

The transfer of energy from the involved (burning) portions is primarily from the flame and radiative in nature. In some cases, conductive energy may be a factor. This is most likely in the slow propagation characteristic of smoldering fires.

This is an End Event in the Event Logic Tree as drawn.

19.4 Control Exposure from General Environment

In addition to the energy directly from the flame, the rate of propagation of fire across a combustible surface is also strongly influenced by any supportive incident radiation coming from any other source. This is important when energy levels in the environment reach levels that impose incident energy on portions of the surface at levels higher than the energy transfer from its own burning flame (Event 19.3). The factors controlling this event are the same as those involved in Event 16.2, Control Fire Intensity.

This is an End Event in the Event Logic Tree as drawn.

17.2 Control Other Means of Extension of Burning Area

In addition to the degree of fire extension resulting from the degree of failure to control surface flame spread, other forms of fire extension can occur involving materials that are either separated from the continuous burning surface, or if part of such surface, are sufficiently removed from the involved area that they are not part of the flame spread phenomena.

Gate 17.2 - The degree of success in preventing other means of extending the burning area is the degree of success in concurrently preventing fire induced ignition of other fuels along with controlling environment induced involvement (flashover and other ventilation control conditions).

18.3 Prevent Fire Induced Ignition of Other Fuels

Fire induced ignition of materials is classified as successive ignitions following the same functional controls as the prevention of fire initiation. For this reason, the guidance in the tree refers the user to Event 2.1. The conditions covered in 2.1 are then repeated at the higher level of energy in the exposing fuel.

This is an End Event in the Event Logic Tree as drawn.

18.4 Control Exposure from General Environment

The energy exposure resulting from the increase in environmental energy conditions can induce flashover or other means of propagation without the direct transfer of energy from the flame or flame plumes of the burning material. The factors controlling this event are the same as those involved in Event 16.2, Control Fire Intensity.

This is an End Event in the Event Logic Tree as drawn.

16.2 Control Fire Intensity

The fire intensity is defined as the position and level of the fire induced energy emitting bodies (solid, liquid, or gas) in the environment. Normally this is defined in terms of temperature distribution and appropriate efficiency factors such as emissivity, specific heat, or other factors relative to heat transfer.

This is an End Event in the Event Logic Tree as drawn, however, Functional Branch C outlines the elements that are the parametric variables controlling the energy characteristics of a given environment.

Functional Branch C - Fire Intensity (Figure 12)

The overall energy characteristics of an environment are the combined function of the rate of energy production, both at any instant, and the history of that production through the course of the fire (C-1); the energy losses, both at any instant, and the history of energy losses through the course of the fire (C-2); and the physical arrangement of the environment (C-3).

The energy production rate is in turn a function of the incident energy (C-4), the response of materials to incident energy (C-5) (as outlined in Functional Branch B), the volatilization rate of the materials as a function of the surface temperature (C-6), and the energy produced per unit mass volatilized (C-7).

The energy produced per unit mass volatilized is a function of the inherent chemical makeup and properties of the materials involved (C-8), and the availability of the air necessary for the combustion process (C-9).

The air for combustion is controlled by the mass available (a function of the physical environment) (C-10), the entrainment of the air into the fire plume (C-11), and the oxygen content of the air (C-12).

Energy losses include those that are vented (i.e., convected from the fire scene) (C-13), those that are radiated from the fire plume (C-14), and those that are transferred to the environment by conduction (C-15).

The influencing physical arrangement of the environment includes all factors of geometry such as height, volume, plan dimensions, and slope. In addition, important environmental considerations relate to the ventilation means by which the fire can obtain the necessary air, and any means available to vent combustion products.

16.3 Control Fire Severity

Fire severity is defined as the total high temperature energy imposed by the fire through its duration or up to point of interest. It is frequently measured in terms of a cumulative time versus temperature curve or occasionally as rate of energy transfer versus time.

Gate 16.3 - The degree of success in controlling severity is the sum of the degree of success in controlling fire intensity and the degree of success in limiting the duration of such intensity through limitation of the total available fuel mass for combustion.

17.3 Control Fire Intensity

Event 17.3 is identical to Event 16.2.

This is an End Event in the Event Logic Tree as drawn.

17.4 Limit Available Fuel Mass

The available fuel mass is defined as all materials that are both capable of releasing energy under fire exposure and subjected to oxidation reaction, given the degree of failure to control fire intensity. This is normally measurement of the mass of such material.

This is an End Event in the Event Logic Tree as drawn.

CHAPTER 8 - CONTROL BY INTERVENTION BRANCH (Figure 6)

15.2 Control by Intervention

Intervention is the application of any fixed or time-of-fire feature or act that causes a termination, slowing, or other reduction in the otherwise potential fire energy threat. Intervention impacts on the outcome only to the degree that it reduces a threat that is not limited or controlled by the features under the Limit Inherent Potential Branch (Chapter 7).

Gate 15.2 - The degree of success of control by intervention is the sum of the degree of success of control by suppression or other forms of termination plus the degree of success of control by confinement.

16.4 Control by Suppression of Burning

Suppression is any action that stops or reduces the extent, intensity, or severity of fire below the inherent potential residual from the degree of failure of Event 15.1.

Gate 16.4 - The degree of success in control by suppression is the sum of the degrees of success of the collective impact of control by removal of fuel availability, cooling or quenching, oxygen deprivation, or other means.

17.5 Control by Removal of Fuel Availability

The removal of fuel availability is any action that extracts fuel from any area where it can become involved as a result of the conditions outlined under Event 15.1. Typical actions include the physical removal of an exposed fuel from the threat of an advancing fire (removal of coal in a pile or bunker) or the covering of a threatened fuel with a barrier to make it inaccessible.

This is an End Event in the Event Logic Tree as drawn.

17.7 Control by Cooling

Cooling is any action that removes heat from the fire bed or the produced hot gases or heated surface. It also includes forms of cooling that increase the difficulty of ignition of unignited materials (primarily by wetting). For the most part, the cooling media is water that may be manually or automatically applied in a traditional form of water or as high expansion foam. A common set of functional criteria apply to all such systems. These criteria are outlined in Functional Branch D.

This is an End Event in the Event Logic Tree as drawn, however, Functional Branch D provides interrelationships of the parameters that control the degree of success of a suppression system.

Functional Branch D - Suppression System (Figure 13)

The capability of a suppression system (manual or automatic) is a function of its availability relative to the area of suppression needs (D-1), its ability to recognize and respond to the need (D-2), and its suppression capability when applied (D-3).

Availability is defined as the proximity of the sensing and activation devices to the fire of a fixed system and the proximity and availability of a safe access path for persons and equipment in cases of manually operated systems.

Response is a combined function of the sensitivity of the responding mechanism (D-4) and its initiation reliability (D-13). Initiation reliability (D-13) in the case of automatic equipment is reliability, in terms of sensing the fire's signature and of activating all elements necessary to deliver the suppression agent.

Sensitivity (D-4) is the response ability of the initiating device (or persons) to the fire situation created by the level of fire characteristics resulting from the degree of failure of Event 15.1.

Sensitivity is a multi-variant function of the signature production and transmission (D-5) and the detector response to it (D-9). In such case, the signature production of interest is that to which the detector can respond.

Signature production and transmission (D-5) is in turn a function of the actual energy signature production of the fire (D-6), the relative position of this production to the detector location and the level of energy in the detectable signature media (D-7), and the space geometry involved (D-8).

Detector response (D-9) is a function of the resistance of the detector to signature admission or accumulation in the actual detection zone (D-10), the signature level required to activate the detector (D-11), and any internal system time constants or delays (D-12). In the case of fixed systems, these internal time constraints are normally mechanical or electronic. In the case of human detectors, they may be administrative.

Suppression (D-3) is the concurrent capability of the suppression system once it has responded (D-14), and the trans-fire reliability in terms of the ability of the system to stay in proper operating order under the ensuing fire exposure for a sufficient period of time to fulfill its function (D-17). Suppression capability is a mass density function relationship between the extent of burning area and intensity of the fire (degree of failure of Event 16.1 and 16.2) (D-15) relative to the agent's capability as applied against the given levels and extent of burning (D-16).

17.6 Control by Oxygen Deprivation

Oxygen deprivation is any activity which prevents oxygen from reaching the fire.

Gate 17.6 - The degree of success in control of fire through oxygen deprivation is the sum of the degree of control obtained by replacing oxygen with inert gas or by exclusion of oxygen by other means.

18.5 Replace Oxygen with Inert Gas

Inert gases include both inert gases especially designed or generated for the purpose of fire control such as carbon dioxide or nitrogen and the inert products of combustion produced by a fire itself.

This is an End Event in the Event Logic Tree as designed, however, the parameters described in Functional Branch D also apply to inert gas systems.

18.6 Exclude Oxygen by Other Means

Other means include any non-gas approach. Such are likely to involve covering the burning material with a solid material such as rock dust or blocking oxygen entry by sealing or other means to prevent the fire from drawing fresh air.

This is an End Event in the Event Logic Tree, however, the performance of systems for exclusion of oxygen are also subject to the parametric element described in Functional Branch D.

17.8 Control by Other Means

All other means of suppressing fire are covered under this category. The principal envisioned mechanisms are those approaches that interfere with the chemical train of the combustion process such as fire extinguishment using halogenated agents.

This is an End Event in the Event Logic Tree, however, as with all other suppression systems the functional parameters in Functional Branch D apply.

16.5 Control by Confinement of Extent of Burning

Confinement of the extent of burning is defined as the establishment of a barrier or other perimeter that prevents the advance of the combustion process beyond some point.

Gate 16.5 - The degree of success of control by confinement is the degree of the concurrent success in maintaining the completeness of the perimeter, its structural endurance, and its thermal endurance.

17.9 Perimeter Completeness

Completeness is the degree to which the perimeter (normally defined by stopping or another barrier) is sufficiently continuous to prevent the passage of fire and flame or other hot gases sufficient to cause ignition on the unexposed side of the barrier. The degree of success in completeness is a measurement of the degree of prevention of ignition passage rather than a measurement of degree of totality of the perimeter.

Perimeter completeness is an End Event in the Event Logic Tree as drawn, however, Functional Branch E lays out the factors that determine the probability of success in terms of completeness.

Functional Branch E - Barrier Completeness (Figure 13)

The functional factors that determine the probability that ignition will pass through any openings in a barrier include the number, size and position of the openings (E-1), the exposing energy level and position as developed from the degree of failure in Events 16.1 and 16.2 (E-2), the location of the flame relative to barrier openings and the amount of excess pyrolysate in the flame body (E-3), and the relative position of external (exposed) fuel on the unexposed side of the barrier vis a vis the barrier openings (E-4). Failure is considered to be the transfer of ignition to a fuel on the unexposed side of the barrier.

17.10 Provide Structural Endurance

Structural endurance is the capability of a perimeter to hold its shape and position during the exposure presented by the imposed fire conditions. Where a barrier or other perimeter member depends upon other members (columns, beams, etc.), the endurance of those members is an integral part of structural endurance.

Gate 17.10 - The degree of success in providing control through structural endurance is a multi-variant relationship between the fire's severity (the degree of failure of Event 16.3), and the structural endurance of the member.

18.7 Fire Severity

Fire severity is the degree of failure to control the severity as defined under Event 16.3.

This is an End Event in the Event Logic Tree as drawn.

18.8 Structural Endurance Capability

Structural endurance is the capability of a perimeter element and its supporting members as installed and protected at the time of fire to withstand and hold their shape, form, and load when subjected to fire.

This is an End Event in the Event Logic Tree, however, Functional Branch F points out the two essential considerations in functional parameters.

Functional Branch F - Endurance (Figure 13)

Endurance of a member exposed to fire is a combined function of the inherent endurance of that member (F-1) plus any endurance enhancement applied at the time of exposure (F-2). Endurance enhancement is most likely in the form of water spray or other means intended to reduce the impact of energy incident on the member.

17.11 Provide Thermal Endurance

Thermal endurance is the capability of a perimeter element to resist the conductive transfer of energy from the exposed to the unexposed side. The measurement of the degree of success is the degree to which ignition through energy transfer is avoided.

Gate 17.11 - The degree of success in providing control through thermal endurance is a multi-variant relationship between fire severity and the thermal endurance response of the element.

18.9 Fire Severity

Fire severity is identical to the fire severity described under Event 18.7.

This is an End Event in the Event Logic Tree as drawn.

18.10 Thermal Endurance Capability

Thermal endurance capability is the ability of the perimeter system as installed to prevent the transfer of energy from the exposed to the unexposed side.

This is an End Event in the Event Logic Tree as drawn, however, Functional Branch F provides factors related to the development of endurance.

CHAPTER 9 - MASS PRODUCT THREAT BRANCH (Figure 7)

14.2 Control Mass Products Threat

Mass products are defined as the various chemical species and particulate products generated by the combustion process or by efforts to extinguish or control that process. Mass products also include any air or other gases entrained into the flow of fire generated products. Mass products include, but are not limited to, all of those fire products usually referred to as smoke and toxic gas.

Gate 14.2 - The degree of success in controlling mass product threat is the sum of the degree of success in controlling the production of such products plus the degree that the movement of those products produced is managed.

15.3 Control Product Production

Product, as used herein, is the conglomerate airborne material produced as byproducts of fire, airborne elements of extinguishing agents, and any products produced as a result of the application of such extinguishing agents in the fire environment.

Gate 15.3 - The degree of success in controlling product production is a multi-variant relationship between the fire energy threat (i.e., lack of control of such threat under Event 14.1) and the products produced given such threat.

16.6 Fire Energy Threat

Fire energy threat is the degree of failure of Event 14.1, that is, the extent and magnitude of fire threat that will potentially be available. The dimensions of measurement are in terms of rate of energy release with such additional factors as are pertinent to production of product gases. These factors include variables such as extent of flaming and sufficiency of oxygen.

This is an End Event in the Event Logic Tree as drawn.

16.7 Products Produced

The products defined by this event are those produced when the material is exposed to the fire energy threat defined in 16.6, including the impact of any intervention approach covered under Event 15.2.

This is an End Event in the Event Logic Tree as drawn.

15.4 Manage Product Movement

Product movement is the mass transfer of all or part of the products produced.

Gate 15.4 - The degree of success in managing product movement is the sum of the degree of success in controlling the movement energy that provides the dynamic head to the gas mass plus the degree to which this movement is controlled given the dynamic head.

16.8 Control Movement Energy

Movement energy is the pressure differential above the normal for the area. This pressure differential is the measurement of the energy forces capable of moving the gas body.

Gate 16.8 - The degree of success in controlling movement energy is the degree to which there is concurrent control of the fire induced energy and energy induced into the gas by other means.

17.12 Control Fire Induced Energy (Buoyancy)

Fire induced energy is that energy caused by the thermal expansion of the gas body due to the fire induced energy which remains in the gas body.

Gate 17.12 - The degree of success in control of fire induced buoyancy is the sum of the degree of success in reducing the gas body temperature by adding a cooling means to the gas mass plus the degree of success in cooling the gas body temperature by transfer of energy to other materials.

18.11 Control by Adding Cooling Agents

Cooling agents are any liquid or gas added to the gas mass that results in a lower temperature of the resulting mass. Most commonly this is either from dilution with cooler air or from a water spray, automatically or manually applied.

This is an End Event in the Event Logic Tree as drawn.

18.12 Control by Transfer to Other Masses

Heat transfer to other masses is defined as that heat conducted to masses such as the roof faces and ribs of the mine as a result of the contact of the hot gases with those bodies or similar transfer by radiation. Each of these transfers is a function of the temperature differential between the gas body and the energy receiving surface. In the case of radiant transfer, it is also a function of the emissivity (energy transmission efficiency) of the gas.

This is an End Event in the Event Logic Tree as drawn.

17.13 Control Other Gas Movement Forces

Other energies include any mechanism other than the entrained heat that causes a pressure differential resulting in gas movement. (Examples of sources of such energy would include fans, barometric pressure differentials, and wind.)

Gate 17.13 - The degree of success in controlling other gas movement energy is the degree of success in the concurrent control of each such potential energy.

18.13 Control Mechanically Induced Forces

Mechanically induced forces are those forces developed by a mechanical arrangement designed to move air or provide gas pressure differentials capable of moving the gas mass. Generally this is dominated by the mine ventilation

system but also includes any casually produced forces such as might be induced by any piston action of a hoist or other mechanism.

This is an End Event in the Event Logic Tree as drawn.

18.14 Control Barometric Induced Forces (Stack Effect)

Barometrically induced forces or stack effect are those that result from the pressure differential caused by the difference in barometric pressure between two points in the mine system and is normally a function of the height of the shaft and the total barometric pressure resting at the base of the shaft versus the total barometric pressure in some other connected part of the system.

This is an End Event in the Event Logic Tree as drawn.

18.15 Control Wind Induced and Other Forces

Wind induced forces are those caused by natural winds that may either blow into the mine or across the face of an opening. "Other forces" is a catch-all statement to cover any other gas movement energy forces. No examples of such other forces are included.

This is an End Event in the Event Logic Tree as drawn.

16.9 Control Movement

The movement of a gas body is the transfer of a mass from one location to another. This event is conditional on the movement energy residual due to the degree of failure involved in Event 16.8.

Gate 16.9 - The degree of success in control of movement is the sum of degree of success in obstructing movement with barriers plus the sum of degree of success in managing the fluid dynamics of that not controlled by barriers.

17.14 Obstruct Movement with Barriers

Barriers include any obstacle to the flow of a gas body. In general, a barrier is not effective unless it encloses all or most of the potential gas movement opening. Most barriers have some degree of potential gas leakage, depending on the pressure differential between the clean and smoke laden side of the barrier. The success of barriers is also dependent upon their success as a confinement media as covered in Event 16.5.

This is an End Event in the Event Logic Tree as drawn.

17.15 Manage Fluid Dynamics

The fluid dynamics of concern are the flow, movement, and concentration of species in the gas body. This is considered conditional on the degree of failure to obstruct the movement with barriers.

Gate 17.15 - The degree of success in managing fluid dynamics is the sum of the degree of success in controlling the gas mass concentration, by dilution; controlling the gas mass flow by exhaust or venting; and control of gas movement with pressure differentials.

18.16 Control by Dilution

Control of the gas mass by dilution consists of entering air into the gas mass to reduce the density of harmful products. Dilution in this event is the same dilution as covered under Event 18.11, but the function is different and the resulting degree of success for a unit mass of dilution will not be the same in these two events.

This is an End Event in the Event Logic Tree as drawn.

18.17 Control by Exhaust or Venting

Exhausting or venting in this context is any mechanism that removes the products from the mine using either the buoyant force of the hot gases itself

or a fan induced arrangement which draws the undesirable gases to the venting fan.

This is an End Event in the Event Logic Tree as drawn.

18.18 Control with Pressure Differential

Control by pressure differential covers any approach where a force is created by fans or any other means that develop a head pressure on the clean area higher than the pressure imposed by the gas mass, thereby blocking its advance or forcing its retreat. Frequently pressure differential approaches are used in combination with barriers to control the degree of failure to obstruct gas flow inherent in the barrier. In coal mines, it is also possible to create pressure differentials in selected entry ways without special barriers at the interface.

This is an End Event in the Event Logic Tree as drawn.

14.3 Control Other Fire Induced Threats

"Other Fire Induced Threats" is an open ended definition covering both the identified and potentially yet unidentified threats not covered under the definition of fire energy threats or mass products threats. This includes, but is not limited to, the threats resulting from fire induced depletion of oxygen, roof or structural collapse, and shock waves as might be induced by a fire induced explosion.

Gate 14.3 - The degree of success in controlling other fire induced threats is the degree of concurrent control of fire induced depletion of oxygen, prevention of roof or structural collapse, control of shock waves, and control of other threats.

15.5 Control Oxygen Depletion

Oxygen depletion is the lowering of the oxygen fraction in a portion of the mine below that necessary for life support. Fires, fire induced conditions, and efforts to attack fire may all result in depletion of the oxygen in the environment. It may occur in the fire product gas stream or in other areas.

This is an End Event in the Event Logic Tree as drawn.

15.6 Prevent Mine Collapse

Mine collapse is defined as the failure of any part of the mine roof or of any other element in a manner that poses a threat.

This is an End Event in the Event Logic Tree as drawn.

Prevent Hazardous Shock Waves or Other Threats

Ignition of combustible gases such as methane or carbon monoxide, or other environmental situations, can initiate a shock wave or pressure surge through the mine shaft posing threat to persons and property.

Other threats are expected to occur but have not been defined at this stage of development of the Event Logic Tree. The inclusion of "Other" in this gate is to maintain an open ended system permitting future analysis of any unidentified threats.

This is an End Event in the Event Logic Tree as drawn.

CHAPTER 11 - LIMIT OF EXCLUDE "EXPOSED" BRANCH (Figure 9)

24.1 Limit or Exclude "Exposed"

The term "exposed" is defined as those persons, property, or operational capability whose harm would be detrimental to the achievement of the fire safety objectives stated in Event 1.0. Exclusion is defined as prohibiting entry of the "exposed" into the mine. Limit is defined as allowing entry but restricting the total amount, or concentration of importance with the mine.

Gate 24.1 - The degree of success in achieving protection of the "exposed" by limiting or excluding the "exposed" is the degree that persons, property, or capability that might otherwise be in the mines and subject to harm are kept out of it.

The prominent approaches are identified as individual events in the Event Logic Tree. Each is mutually exclusive from the other.

25.1 Limit Access to the Mine

Limiting access to the mine can be by a prohibition on entry of persons, property, or operations into the mine. It can include the relocation of an essential process outside the mine as a surface operation, etc.

26.1 (Limit Access to Mine) at All Times

26.2 (Limit Access to Mine) at All Times of Specific Conditions, Threats or Potentials

Examples would include clearing of the mine upon the discovery of a hazardous condition such as unacceptable methane concentration or the undertaking of some specifically dangerous operation such as under certain blasting conditions.

25.2 Limit Access or Concentration of "Exposed" in Specific Areas of Mine

The prime example is the prohibition of entering under unsupported roofs. Other examples might include prohibition of or limitation of access to

abandoned areas, limitation of the number of persons in specific work teams, etc.

26.3 Limit Access or Concentration to Specific Areas (at all times)

26.4 Limit Access or Concentration in Specific Areas at Times of Specific Conditions, Threats, or Potentials

25.3 Evacuate in Case of Potential Threat

The removal or evacuation of persons at the time of threat such as discovery of fire. It may consist of removal of all persons or removal of those persons who are either specifically endangered or do not contribute to the control of the threat.

CHAPTER 12 - SAFEGUARDING "EXPOSED" BRANCH (Figure 10)

24.2 Safeguard "Exposed" from Given Threat

"Exposed" is any person, property, or production capability whose harm will reduce the degree of accomplishment of the objectives in Event 1.0. The specific "Exposed" covered in this event represents all the potential "exposed" that is not excluded or limited by Event 24.1. The threat is that which is residual from the result of the degree of failure of Event 13.1, Control Threat.

Each of the events in this branch are functionally dependent on all or the applicable portion of Functional Branch G.

Gate 24.2 - The degree of success in safeguarding the "exposed" from a given threat is the sum of the degree of success in protecting the "exposed" in their work place plus the degree of success of relocating the "exposed" to in-mine refuge areas plus the degree of success in evacuating the "exposed" from the mine.

Functional Branch G. Factors Controlling Protection of "Exposed" (Figure 14)

The functional factors related to protection of "exposed" involve a multivariant relationship between the total threat (described in terms of extent, intensity, and severity resulting from the degree of success in 13.1 (G-1)), and the avoidance of harm by the "exposed" given that threat (G-2).

The ability to avoid harm is in turn a multivariant function of the tolerance of the "exposed" (in the case of humans, their ability to survive and/or function, in the case of physical property the ability to withstand damage under the given degree of exposure) (G-3), and the positions of the "exposed" relative to the position of the threat (G-10). The position of "exposed" in turn is a function of his ability to move (G-4) and movement actions that use that ability (G-11).

The ability to move (G-4) is a function of the physical capability of the "exposed" to move (or be moved if the "exposed" is inanimate) (G-5), and the fire safety characteristics of the movement route (G-6). The fire safety characteristics of the movement route (G-6) can be described as functions of the safety of the access from the position of the "exposed" to the route (G-7), the capacity or capability of the route to handle the "exposed" (G-8), and the security of the route (or place of protection if such a place is involved) against the intrusion of fire products (G-9).

The security of the route or place can be determined through events that are the same as the events described in Gate 16.5, Control by Confinement if the objective of that gate is revised from "Extent of Burning" to "Extent of Intolerable Conditions".

The movement actions (G-11) using the ability to move is a combined function of the cue generation (initiation of information that a threat is present - e.g., alarm, smoke, word of mouth, etc.) (G-12); the cue reception (the transmission of the signal into understood and knowledgeable information to the responding person or device) (G-13); the manner in which the person or responding equipment receives and analyzes that information and makes a safeguarding decision from it (the decision of concern is the safeguarding action decision resulting in the degree of physical movement and the route of such movement) (G-14); and finally, the actual physical act of movement (G-15). The series of functional factors G-12 through G-15 are sequential in occurrence.

25.4 Provide Protection in Place

Protection in place is defined as the provision of protection in the normal work place or other location of the "exposed" without the necessity of relocation to a specific area. Protection in place can include that type of protection which is conditional on the location and degree of the threat (i.e., a place may be appropriately protected when the threatening fire is remote and/or barricaded but be unsatisfactory as a place of refuge with a different location or degree of fire exposure). For example, barricaded fires in gob areas may leave the entire rest of the mine adequately protected in place.

The degree of success in providing protection in place is the sum of the degree of success provided by safeguards that provide their protection inherently without any special kind of fire action plus the degree of success achieved from safeguards initiated at time of fire.

26.5 Provide Inherently Safeguarded Place

Inherently safeguarded places are those that provide their protection without the need for any adjustments at the time of fire. A prime example of this is a fixed fire resistive barrier. The degree of safeguarding of the place must be sufficient to prevent harm, but the safeguarding may be either of a temporary nature whereby the place may have to be evacuated at some level of threat or, the place may be designed to be tolerable for the duration of the maximum possible threat. The degree of success is a function of this quality and the level of threat.

This is an End Event in the Event Logic Tree as drawn.

26.6 Threat Initiated Safeguard

To the degree that safeguards are not inherent, they may be of a type that is initiated at the time of fire. Prime examples would include automatic closing barriers or the erection of temporary stops or barriers by miners. As with the inherent safeguard, they may provide temporary or limited security or may be designed to provide tolerability for the duration of the potential fire.

This is an End Event in the Event Logic Tree as drawn; however, in addition to Functional Branch G (which applies to all of the events in this branch), Functional Branch H outlines factors controlling the success of threat initiated safeguards.

Functional Branch H. Threat Initiated Safeguards (Figure 14)

Active systems are fire safety systems that perform their function by responding and performing in a different mode at time of fire than in their normal non-fire condition. The functional requirements for such systems are

that they must respond when called upon (H-1), and upon response must perform their essential function (H-2). The functional control of response capabilities are identical to those in the sub-branch, Response, of Functional Branch D.

The performance requirements vary according to the type of performance necessary but relate in each case to functional entities covered under threat control such as Functional Branch F, where a barrier is expected to exclude fire products; Event 15.4, covering the management of product movement; Event 15.5, covering control of oxygen depletion, etc.

25.5 Relocate "Exposed" to In-Mine Refuge Areas

Relocation to in-mine refuge areas involves emergency movement of the "exposed" from their normal place in the mine to some safeguarded place. The safeguard may provide temporary or duration of fire tolerability. The functional requirements of both Functional Branches G and H apply.

This is an End Event in the Event Logic Tree.

25.6 Evacuate Mines

Evacuation is the removal of the "exposed" through a safe area external to the mine. In terms of life safety, it is the primary means of protection of the exposed. Functional Branch G applies in this case.

This is an End Event in the Event Logic Tree.

CHAPTER 13 - STATES AND TRANSITIONS

In recent years a combined concept of the interrelationship of people, the environment, and fire has emerged. This concept was introduced by Nelson, in terms of the fire environment in 1972 [1] and expanded by him to include the interrelationships of fire and people in 1977 [2]. Elements of the approach are fundamental to the Building Fire Model developed under the auspices of the National Fire Protection Association [3]. The state-transition concept is felt to allow better focus on the worth and impact of prevention, control, or protection strategies.

This concept is based on the premise that:

1. Within any given environment (mine, building, or other location), fire behavior and the behavior of persons involved can be expressed as a series of describable behavior patterns connected together to form sequences.
2. The fire behavior and people behavior sequences are separate but can be (and often are) inter-reacting with each other.
3. The separate behavior patterns that make up the sequence consist of individual periods during which there is a consistency of the form of fire growth and/or inter-play between fire and its environment, or of the response of individuals or groups of individuals to the resulting threat. These periods of consistent behavior are referred to as states. In some texts, the terms "realms" or "regimes of burning" are also used in reference to states of fire. In human behavior research, the term "episode" is more commonly used than states to describe periods of human behavior. The term episode is used for that purpose.
4. Each state (or episode) starts and ends with a change in response to the environment of sufficient magnitude to cause a change in the patterns of behavior. In the fire behavior sequence, these are referred to as critical events. In the human behavior sequence, they are referred to as decisions or decision points.

5. Many of the states of fire behavior are not static but vary with time in the state. In such situations, the degree of threat or harm can vary according to the period of time within the state. The rate of variation, however, will differ from state to state. The fire behavior sequence, as outlined herein, is such that generally an increase to a higher numbered state constitutes an increase in both the level of threat and the rate of increase of threat for a period of time in that state.
6. At any instant in the combined fire behavior/human behavior sequence there is a single overall level of fire safety performance (or conversely fire risk or harm). This level is represented by the top event (Event 1.0, Fire Safety Performance) in the Event Logic Tree.
7. The fire safety performance is enhanced by the degree to which the fire safety systems and efforts to maintain the fire in a lower order state succeed, and the degree to which the period of advance into any more destructive or threatening state is limited. Similarly, those objectives related to the well-being of persons are enhanced by the degree to which the human behavior episodes or activities avoid the simultaneous occupancy of a space by intolerable fire threats and humans.
8. The events in the Event Logic Tree govern the states that a fire is in, the transitions between states, the advance within a state, and the human behavioral sequence. In general only a portion of the events are operative in any state or involved in any transition. Those factors that control the situation at any moment are referred to as dominant factors for that state or transition. In general, the entry of a new dominant factor results in a state change.

Fire Behavior Sequence

The choice of states depends on the level of detail desired in examining the fire condition. For the purposes of this study, six major states of fire have been selected and have been sub-divided into their most important sub-states. The six basic states are:

- State 0, Non-burning
- State 1, Development on First Ignited Fuel
- State 2, Multi-item, Fuel-controlled Burning
- State 3, Ventilation Controlled Burning
- State 4, Multi-spacial Involvement
- State 5, Mine Fire

a. State 0, Non-burning

This state covers all conditions when fire does not exist. The sub-states cover the range of conditions from the normal or static situation where no fire threat exists through the varying levels of precursor situations in which the potential of fire initiation increases through heating or chemical reactions of potential fuel. The critical events or transitions from the non-burning state include the various types of fire initiation that may occur. The actual transition from non-burning to a burning state may be defined differently under different circumstances. Most of these circumstances are listed in the critical events for transition from the state. It is considered legitimate to define fire initiation by any of these critical events according to the needs of the user of the concepts. It is essential, however, that once such a decision has been made that this working definition be maintained or that any variation be clearly identified.

The sub-states of State 0, Non-burning, identified for the purposes of this paper are:

- 0.0 Static
- 0.1 Preheat/self heating
- 0.2 Vaporization (of hydrocarbons)
 - 0.2.1 Lean
 - 0.2.2 In explosive/flammable range
 - 0.2.3 Rich

0.3 Pyrolysis (without combustion)

The critical events governing transition from State 0 include:

A.1 Supported smoldering

A.1.1 To State 1

A.1.2 To State 2

A.2 Self-sustained smoldering

A.2.1 To State 1

A.2.2 To State 2

A.3 Supported flaming

A.3.1 To State 1

A.3.2 To State 2

A.4 Self-sustained flaming

A.4.1 To State 1

A.4.2 To State 2

A.5 Explosion

A.5.1 Non-disrupting - No subsequent ignitions - To State 0

A.5.2 Non-disrupting - Subsequent ignitions to States 1, 2 or 3

A.5.3 Physically disrupting of spacial barrier - No subsequent ignitions - To State 0

A.5.4 Physically disrupting of spacial barrier - Subsequent ignitions, to States 1, 2, 3, 4 or 5

b. State 1, Development on First Ignited Fuel

This state covers the development of fire from the initiation of burning to the point where the fire either terminates or extends to one or more additional items (or involves the entire mine or section of the mine in a ventilation controlled fire). By definition, this state is relegated to fuel controlled burning with little or no influence on the burning item as a result of energy feedback from the overall surrounding environment. In this state, not only the basic physical properties of the material, but

its shape and form and its proximity to other ignitable material play important parts.

The sub-states of State 1, Development on First Ignited Fuel include:

- 1.1 Single surface spread
 - 1.1.1 Single-dimensional
 - 1.1.2 Two-dimensional
 - 1.1.3 Three-dimensional
- 1.2 Multi-surface spread
 - 1.2.1 Single-dimensional
 - 1.2.2 Two-dimensional
 - 1.2.3 Three-dimensional
- 1.3 Gas phase propagation
- 1.4 Steady state
- 1.5 Decay

The critical events involving transition from State 1 to an additional state include:

- B.1 Ignition of additional item - fuel controlled burnings
 - B.1.1 Individual item(s) (separate fuel package(s)) - to State 2
 - B.1.2 Combustible surface(s) - to State 2
 - B.1.3 Combustible gas/vapor/dust mass
 - B.1.3.1 Non-disrupting - to State 3
 - B.1.3.2 Physically disrupting of spacial barriers - to State 4
- B.2 Transfer to ventilation controlled burning - to State 3
- B.3 Extend to multi-compartment burning - to State 4
- B.4 Decay to State 0

c. State 2, Multi-item, Fuel-controlled Burning

This state is an extension of State 1 in which the critical event involved has resulted in the spread of fire between items, increasing the basic fuel bed in both quantity of fuel and extent, but has not involved a change from fuel controlled burning or reached an intensity that produces a significant energy feedback from the surrounding environment.

The sub-state of State 2 include:

- 2.1 Individual burning (repeat State 1 for item(s) 1 to N)
- 2.2 Coalesced burning (repeat State 1 for coalesced fuel package)

The critical events governing the transitions from State 2 to another state include:

- C.1 Transfer to ventilation controlled burning to State 3
- C.2 Decay to State 1
- C.3 Extend to multi-compartment burning - to State 4
- C.4 Decay to State 0

d. State 3, Ventilation Controlled Burning

Ventilation controlled burning is that state of fire where the burning rate is controlled by the rate at which the necessary oxygen for combustion can be obtained and entrained in the effluent products liberated by the feedback energy from flame, hot gases, or heated surfaces to exposed fuel. The transition from fuel controlled burning to ventilation controlled burning would normally be expected to force evacuation of all or part of the mine and likely involve the coal seam.

The sub-states within State 3, Ventilation Controlled Burning include:

- 3.1 Steady pyrolysis rate

- 3.2 Decreasing pyrolysis rate
 - 3.2.1 Constant extent of burning area
 - 3.2.2 Decreasing extent of burning area
- 3.3 Increasing pyrolysis rate
 - 3.3.1 Constant extent of burning area
 - 3.3.2 Increasing extent of burning area

The critical events governing the transition from State 3 to another state include:

- D.1 Inter-spacial ignitions - Extend to State 4
 - D.1.1 Unsupported discrete ignition(s) (apply State 1 or 2 in new spaces)
 - D.1.2 Energy supported discrete ignition(s) (apply States 1 or 2 in new space(s))
 - D.1.3 Massive energy supported general ignition (apply State 3 to new space(s))
 - D.1.4 Structural failure (extend space to include newly included area(s))
- D.2 Recede to fuel controlled burning of 1 to N items - to State 2
- D.3 Recede to fuel controlled burning of item - to State 1
- D.4 To State 0

e. State 4, Multi-spacial Involvement

Multi-spacial involvement covers the spread of fire from space to space through unprotected openings or through failure of the fire stopping capabilities of physical barriers. It is expected that advance of fire into State 4 will usually involve ventilation controlled burning in the exposing space. Sub-state 4.1 covers the situation of advance of only ignition sources without transfer of the full energy or joining of the newly involved spaces into a single coalesced fire. In such cases, fire in the additional spaces develops relatively independently of the initial fire. Sub-state 4.2 covers the situation of advance of a full flame front where the additional spaces join the initial fire in one single ventilation controlled incident.

The individual sub-states of the State 4, Multi-spacial Involvement, include:

- 4.1 Separate burning (independent repetitions of states 1 through 3)
- 4.2 Coalesced burning (joining of burning spaces into single coalesced fire)

The critical events marking transition to other states include:

- E.1 Transfer to mine fire - Extend to State 5
- E.2 Decay
 - E.2.1 To State 3
 - E.2.2 To State 2
 - E.2.3 To State 1
 - E.2.4 To State 0

f. State 5, Mine Fire

This state is defined as a fire which so involves the mine as to have reached a steady state of burning and essentially driven all occupants to the surface where the mine cannot be re-entered until the fire decays in some manner to a lower level state.

Human Behavior Sequenced

The sequences of states or episodes of human behavior do not necessarily follow progressively increasing levels of safety or potential of harm. Rather they consist of actions chosen by those involved (as a result of experience, training, or ad hoc judgement) that they believe best for their needs or objectives at the specific time of decision. The basic objective in protection of humans is always the avoidance of occupancy of the same space at the same time by people and by conditions intolerable to people. In fire situations, the fire effect may be moving or may be concentrated in a limited area. The humans involved may or may not be mobile according to the conditions they face and their safety may or may not be dependent upon their actions. In some cases, they may be able to undertake actions to directly mitigate the threat. In other cases, they may only be able to undertake actions to escape or avoid

the threat. The number and type of actions undertaken by people in fire situations are manifold. The following general classifications, however, are proposed as the episodes which can be used to classify the physical acts under Functional Element C-15 of the Event Logic Tree. For the purposes of this paper, these episodes are:

- Episode A, No Action
- Episode B, Investigate
- Episode C, Attack
- Episode D, Alarm
- Episode E, Flee/Escape
- Episode F, Rescue

a. Episode A, No Action

No action is used to define any situation where persons do not undertake any activity relevant to protection of themselves or others or to control of fire. Such actions may include continuing to mine or haul coal, attending to other business, or undertaking some more pressing need (e.g., maintaining life support ventilation to portions of the mine unrelated to the fire).

b. Episode B, Investigate

Investigation includes all of those actions where a person receiving a cue seeks to remove ambiguities or to gain advice or instruction before taking further action. Fire experience indicates that humans tend to assume that risk indicators are indicative of their lower, rather than their higher potential. Often, they seek to remove ambiguities from indistinct or confusing cues or signals, and tend to seek reinforcement before taking unusual actions, even those potentially for their own or their fellow workers well being or for protection of the facility.

c. Episode C, Attack

This episode covers any activities aimed directly at terminating the fire or controlling or mitigating its impact on either people or property. Specific actions would include activities such as, application of extinguishment, closing of barriers to control smoke, or removal of fuel from a fire source.

d. Episode D, Alarm

This episode includes all of those activities in which the existence or the state of a threat is communicated by direct human contact, voice or symbolic alarms, or other means. The alarm may be given to warn of danger, initiate self protection measures, summon emergency assistance, or other purposes.

e. Episode E, Flee/Escape

This episode includes all activities directed at escaping the threat of fire. It includes leaving the mine or taking refuge within the mine.

f. Episode F, Rescue

This episode includes all activities involved in assisting others. It includes those in which a miner assists another in escaping or taking refuge as well as the more formal rescue teams that may enter a mine after the fire has developed to a more advanced fire state.

General Mode

Figure 15 outlines a general model of the interrelationships between the fire behavior sequence and the human behavior sequence. As indicated by this model, fire behavior is looked upon as a series of independent states connected by critical events. Human behavior is a similar series of independent episodes connected by decisions. The two sequences influence each other with stimuli (cues) that flow from the fire behavior to the human behavior sequence causing

action or impacting on the well being of humans. The flow of stimuli is caused by the fire behavior sequence and is proportional to it but entirely separate in its functional aspects. Flow from the human behavior sequence to the fire sequence is however, in the form of impacting actions. The type of impacting action can be any of the behavioral episodes that cause a change in the fire or the ensuing fire threat. Impacting actions can be to the benefit of the overall fire safety performance where they involve or result in intervention in the fire development. Conversely, they can be detrimental to the objective where the actions result in increasing the threat. Typical of such detrimental action might be the opening of a door in or the breaking through stopping in a manner that either diverts the air supply or allows smoke propagation to areas that would not otherwise have been affected.

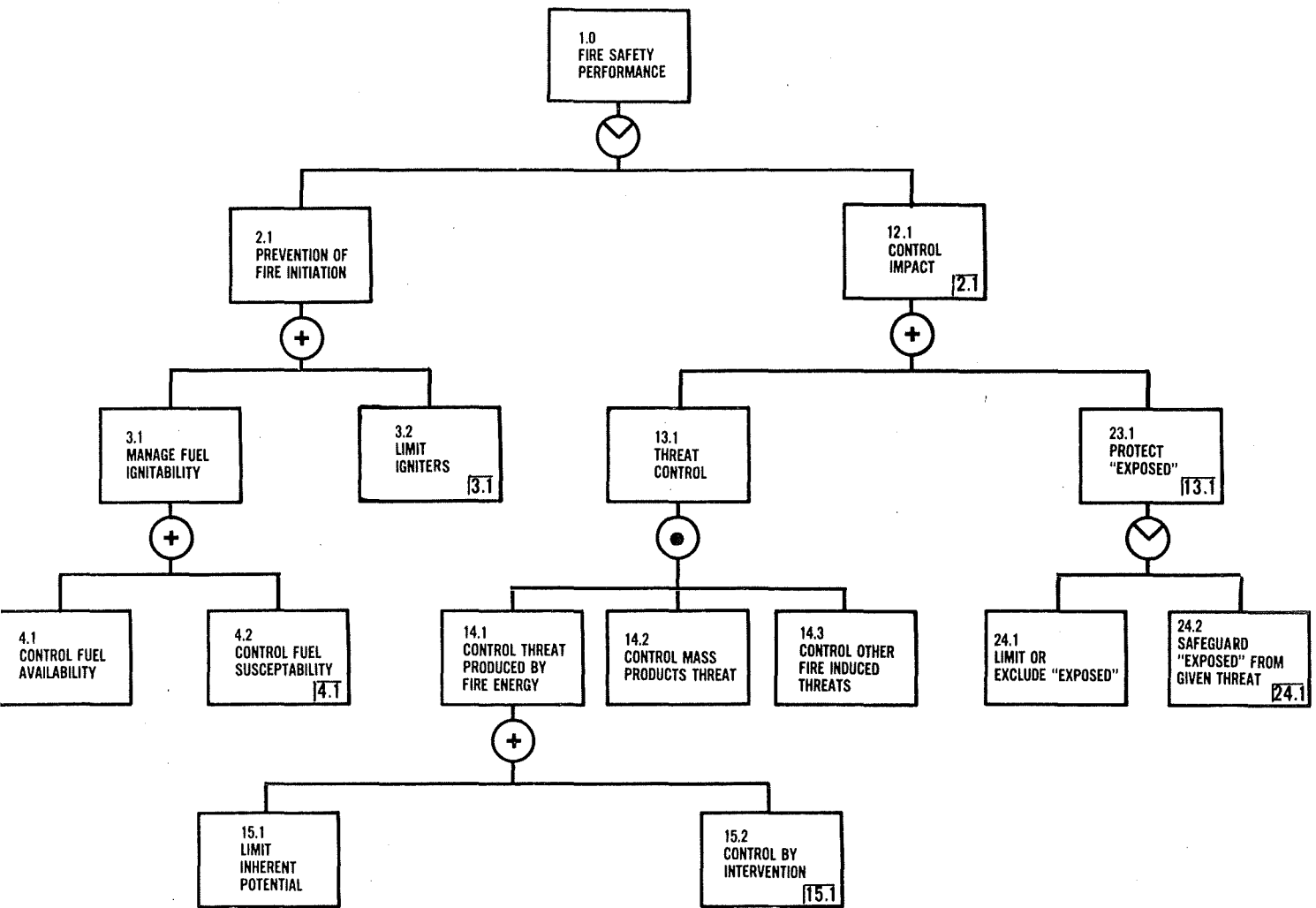









-  - OR - Mutually exclusive (either or, but not both)
-  - OR - Not mutually exclusive (either or, or both)
-  - OR - Multi variant relationship (i.e., probability density function) Conditional event is dependent on both occurrence and magnitude of conditioning event.
-  - AND - Never mutually exclusive, success always dependent on all involved events. Individual events may or may not be conditional on other events
-  - Function - The performance of the above event is a function of the subsequent elements. In this gate the elements are parametric variables.
-  - Events proposed for future development
-  - Given (5.3) reads "given 5.3"
-  - Not (5.3) reads "given not 5.3"

Figure 1. General (overview) Event Logic Tree

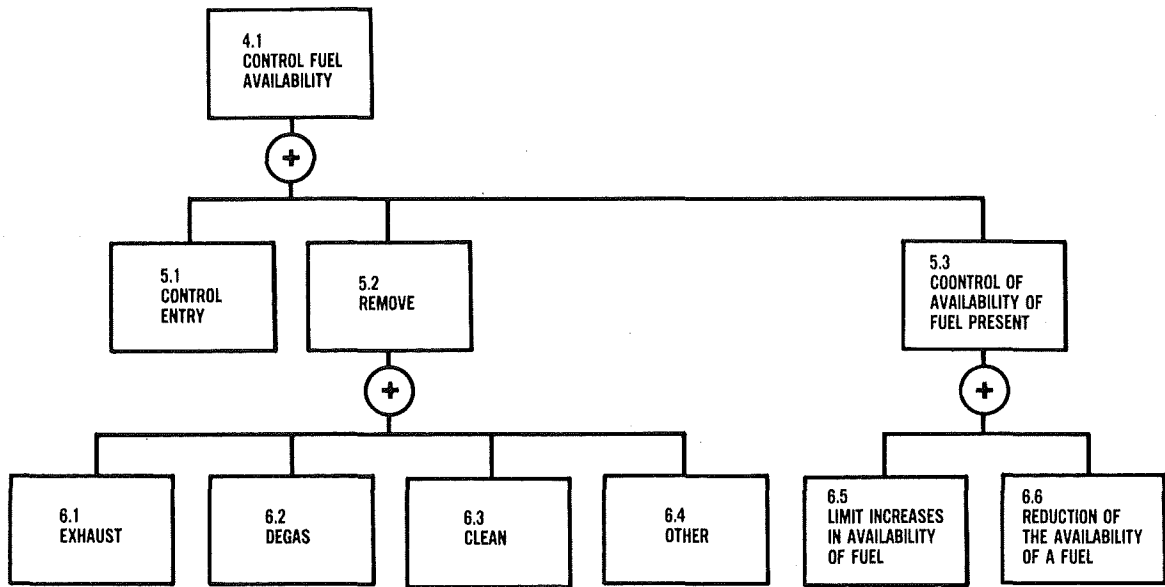

Figure 2. Control Fuel Availability Branch

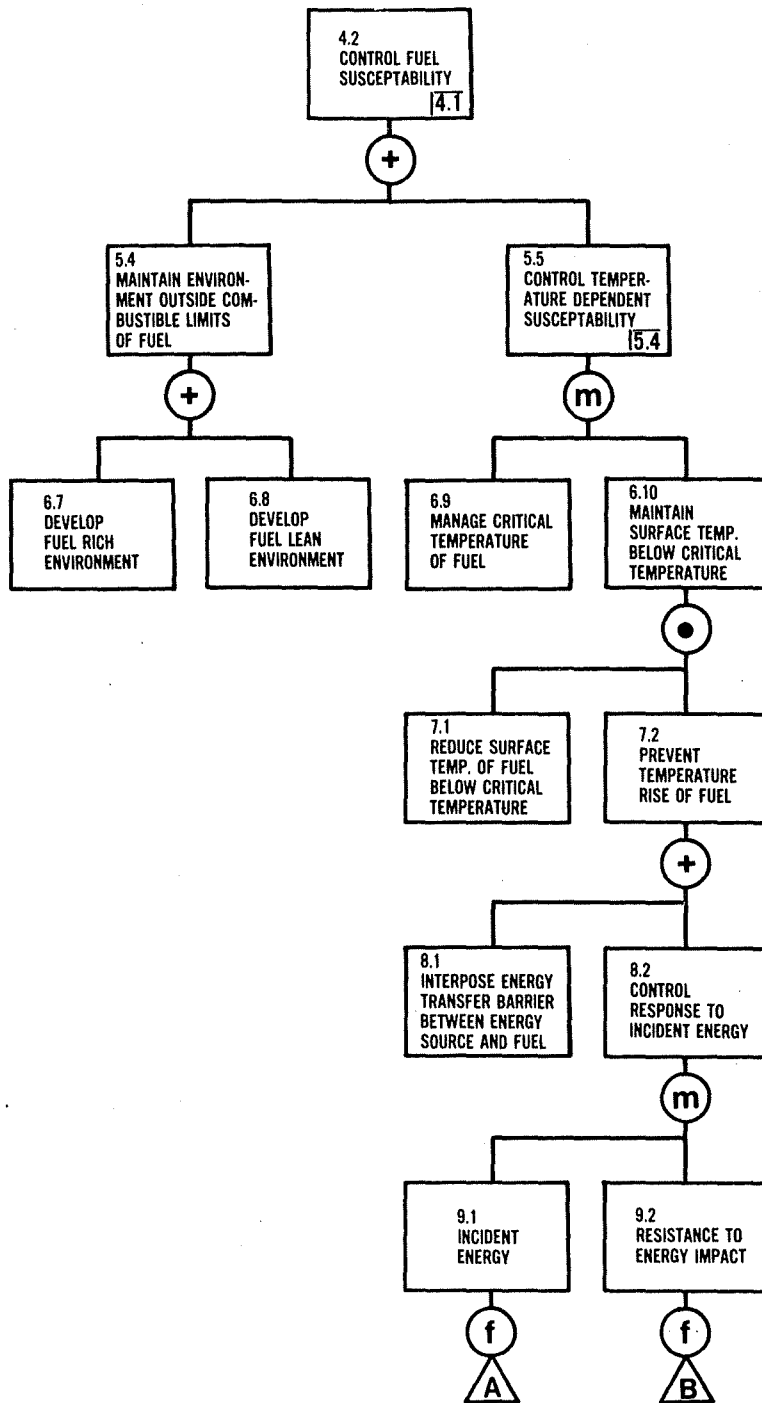

Figure 3. Control Fuel Susceptibility Branch

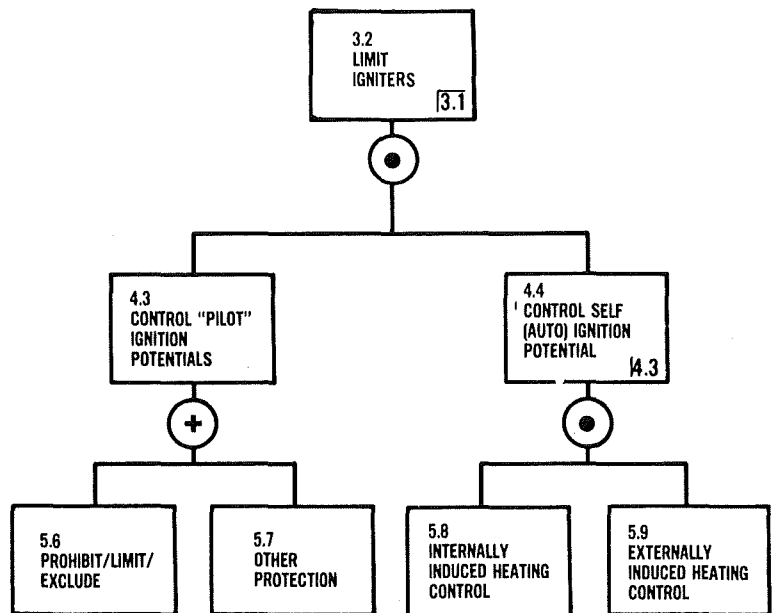

Figure 4. Limit Igniters Branch

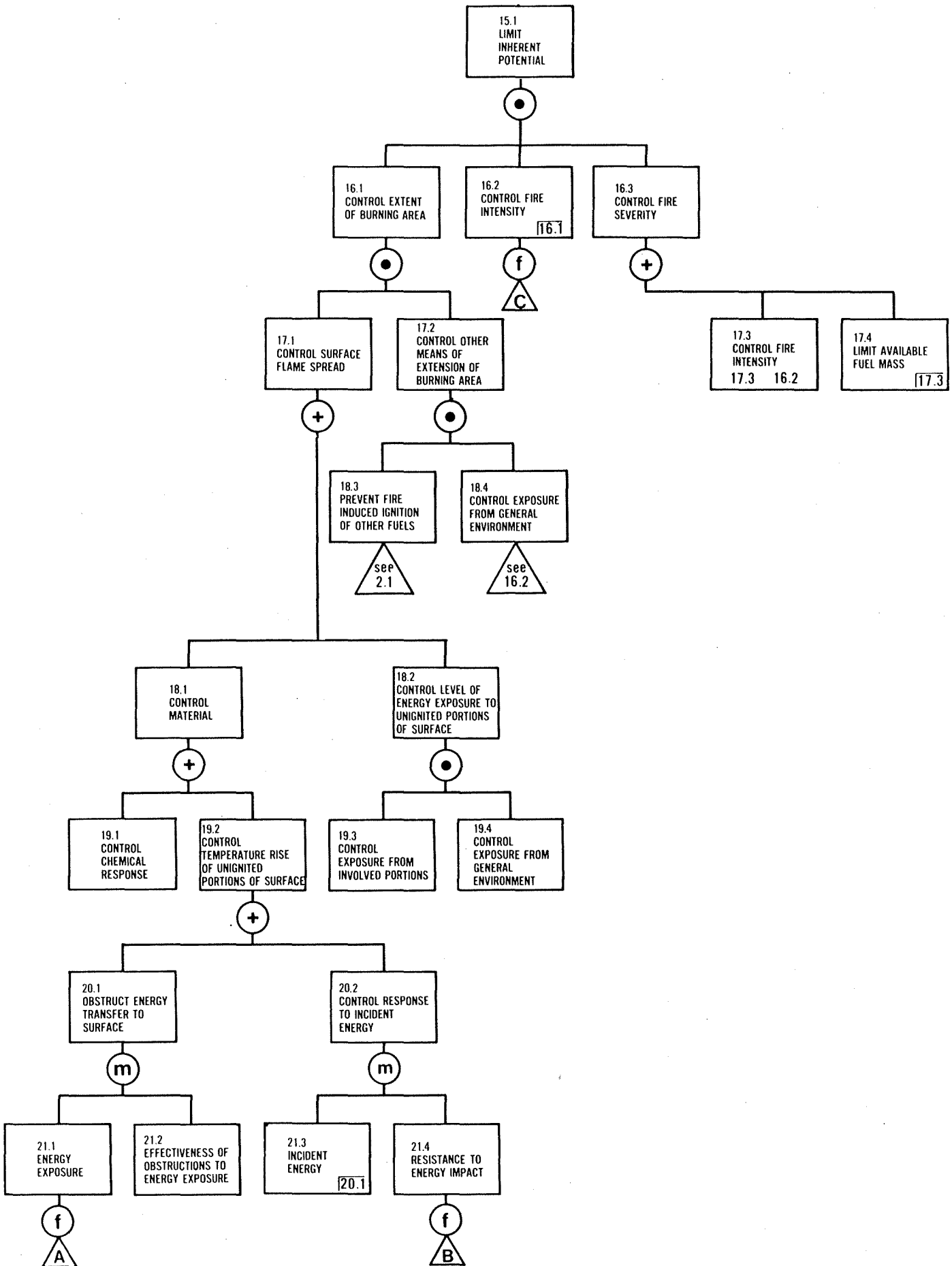

Figure 5. Limit Inherent Potential Branch

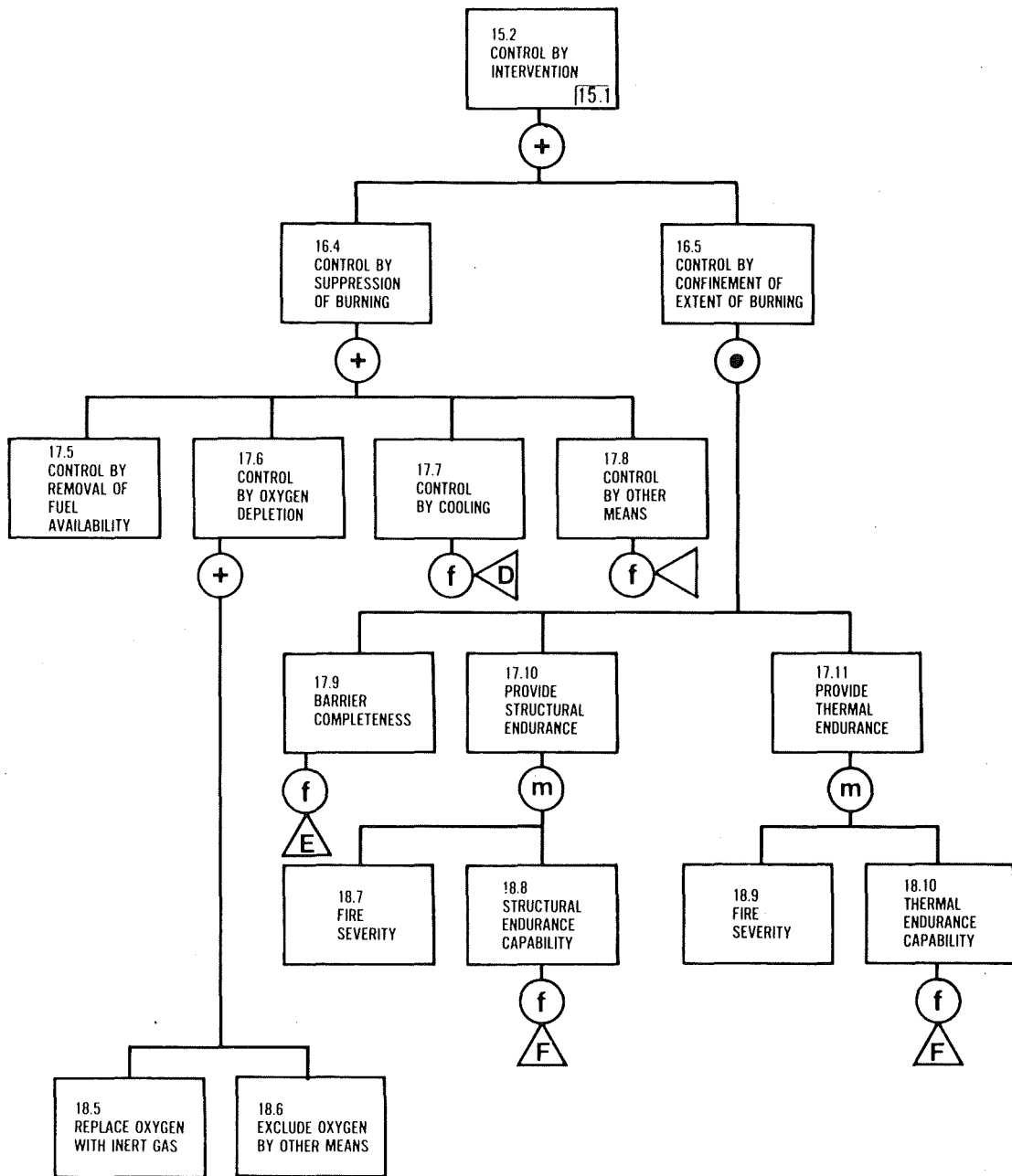

Figure 6. Control by Intervention Branch

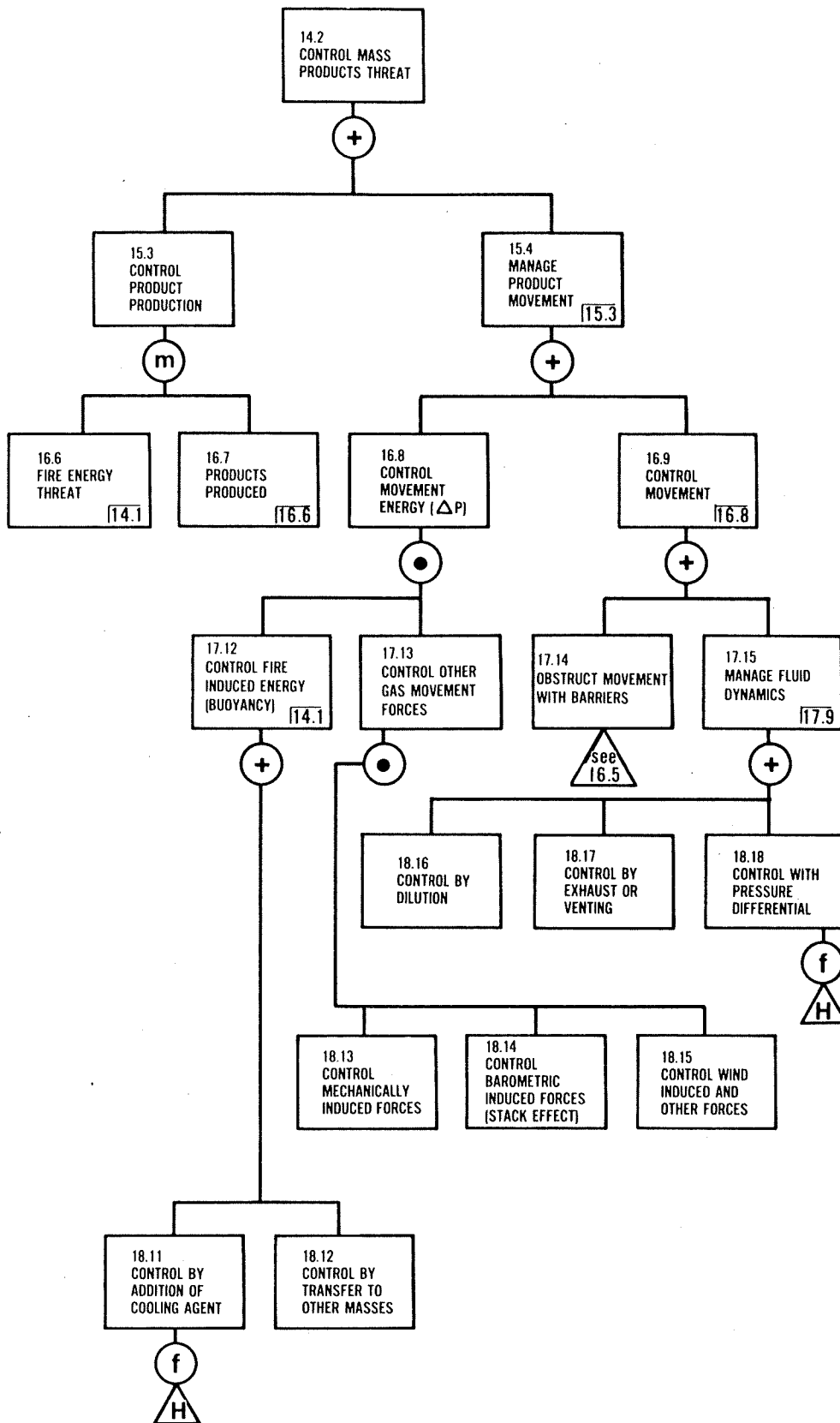

Figure 7. Mass Product Threat Branch

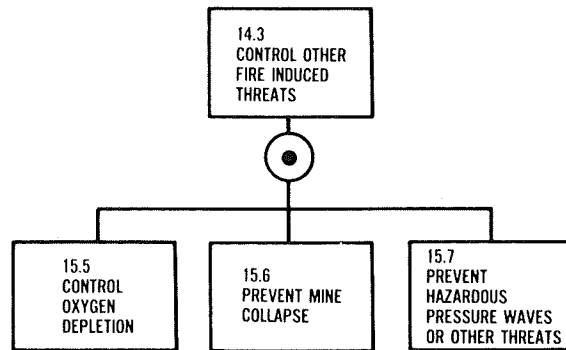

Figure 8. Control Other Fire Threats Branch

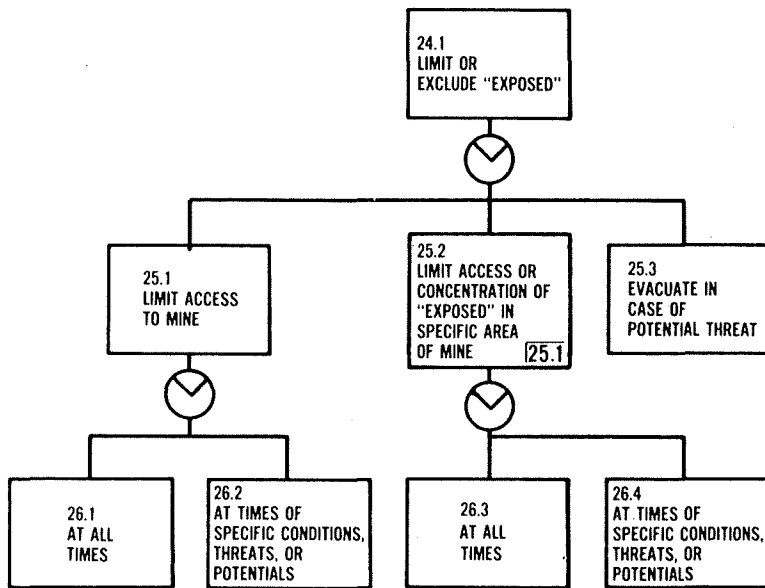

Figure 9. Limit of Exclude "Exposed" Branch

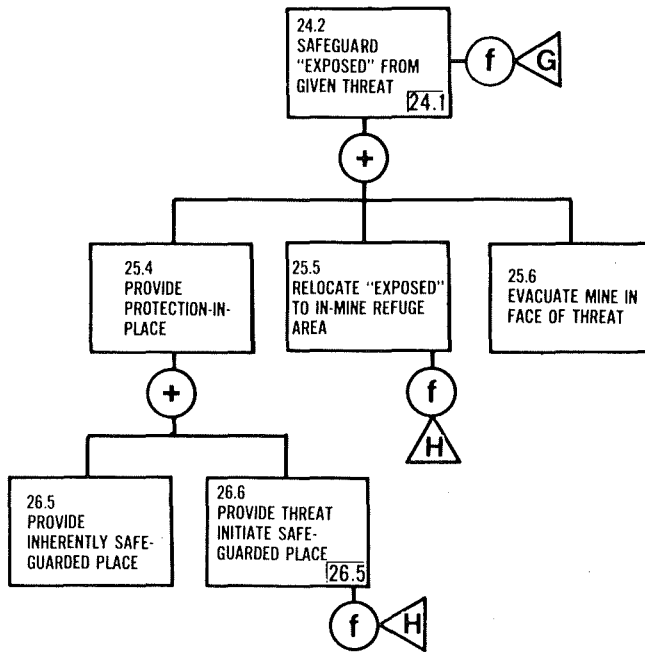

Figure 10. Safeguard "Exposed" from Given Threat Branch

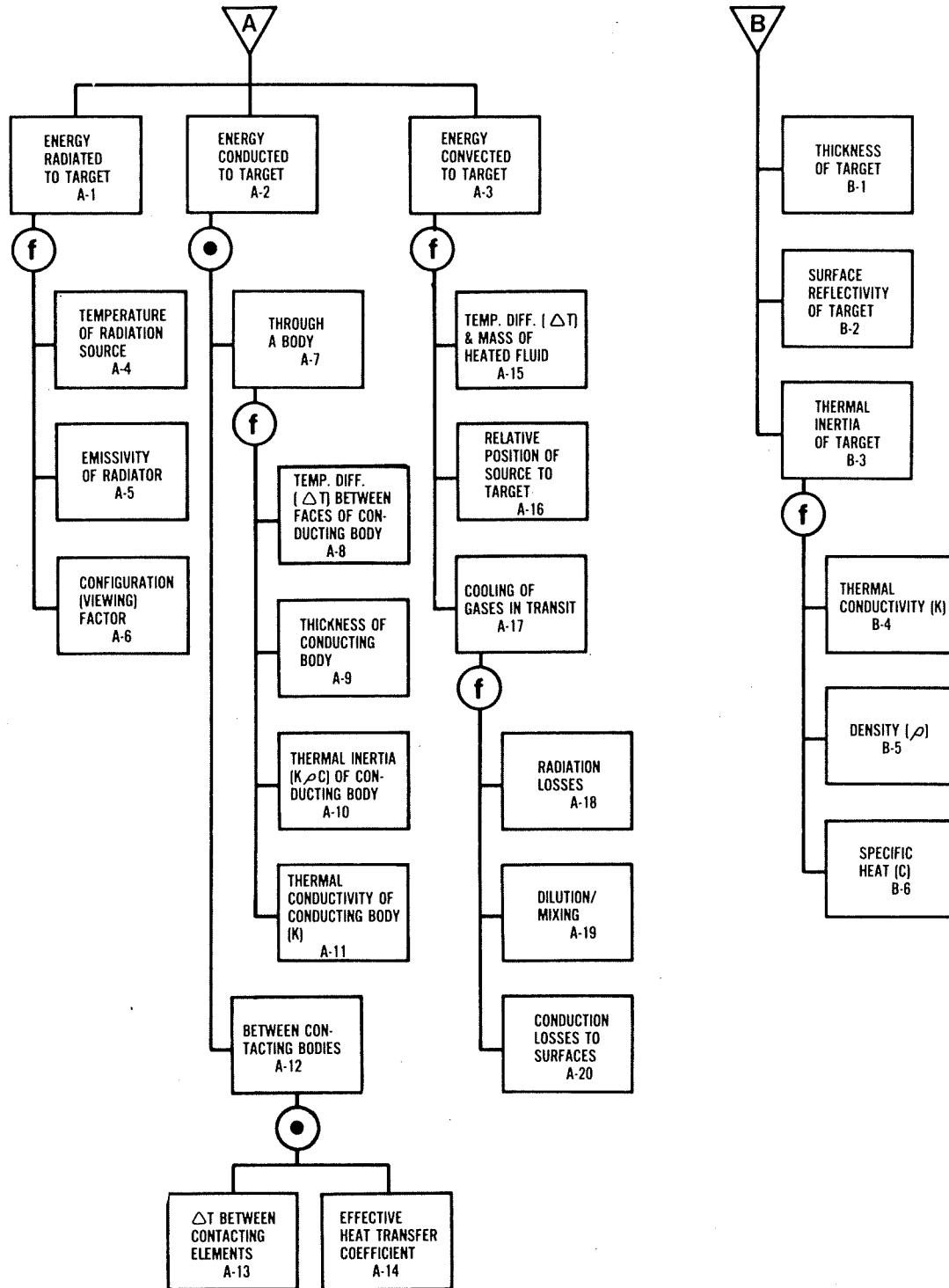

Figure 11. Functional Branches A and B

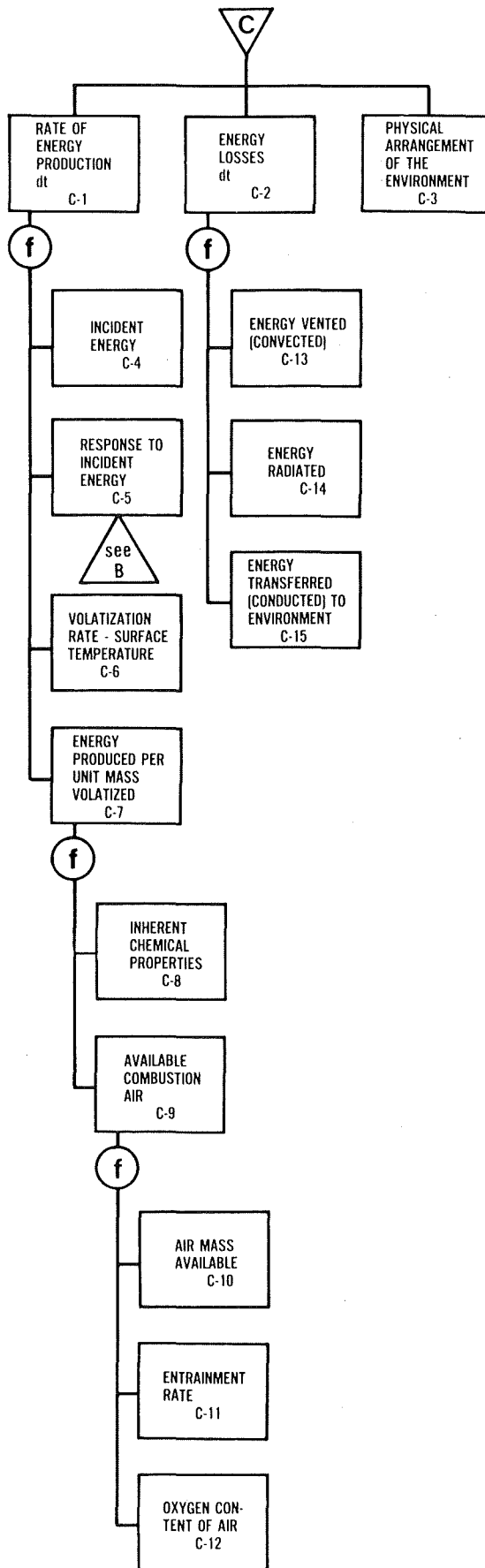

Figure 12. Functional Branch C

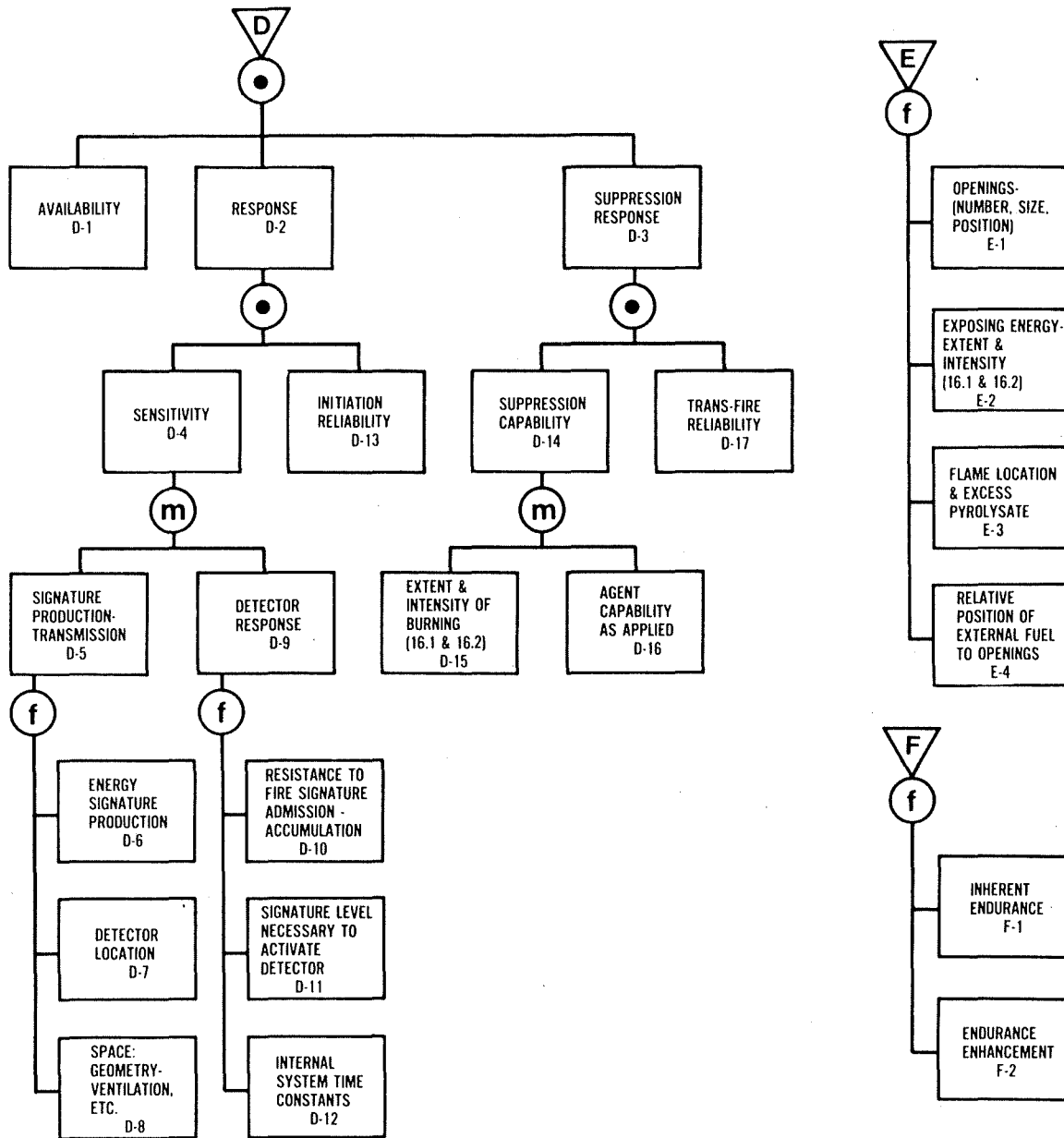

Figure 13. Functional Branches D, E, and F

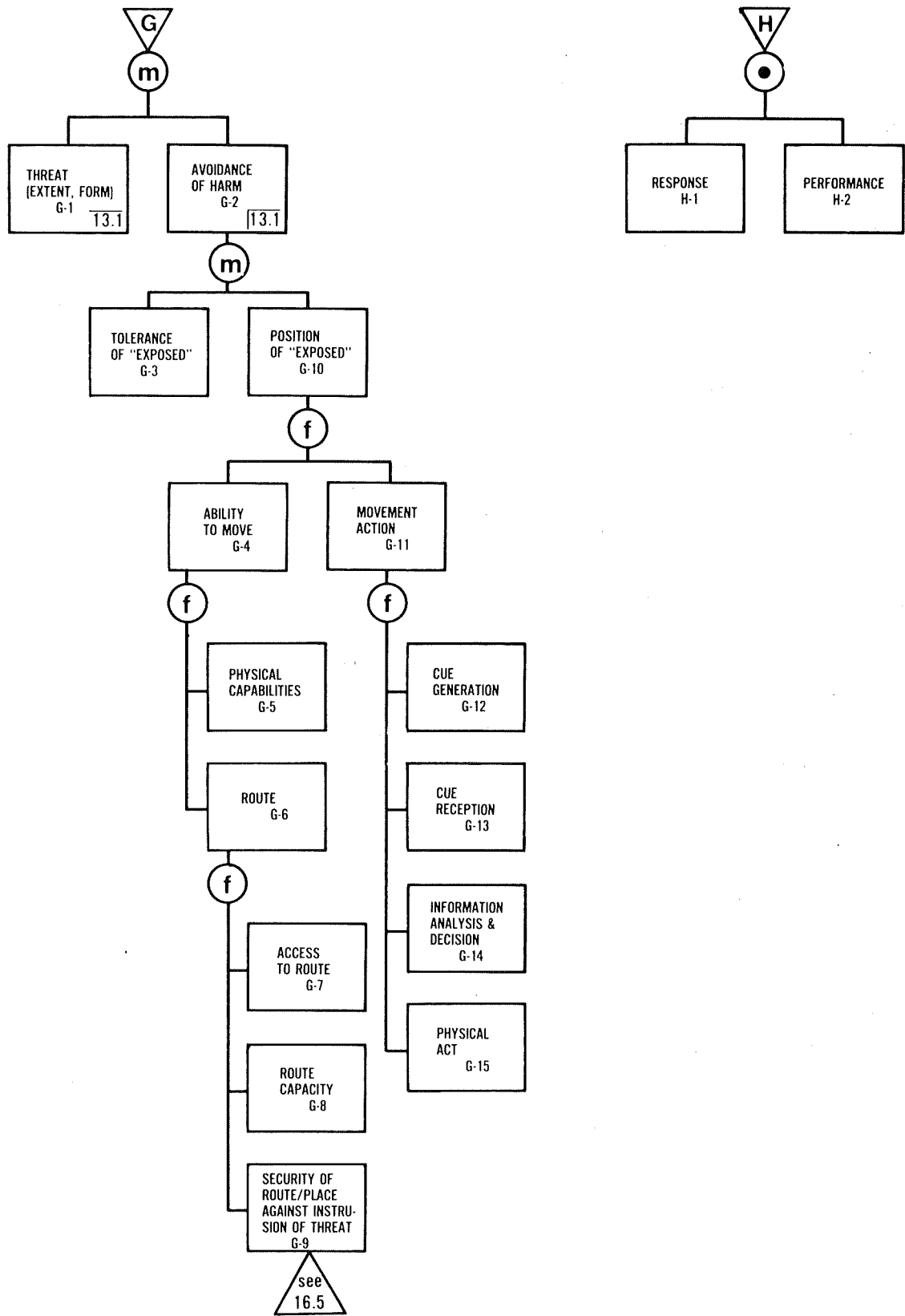

Figure 14. Functional Branches G and H

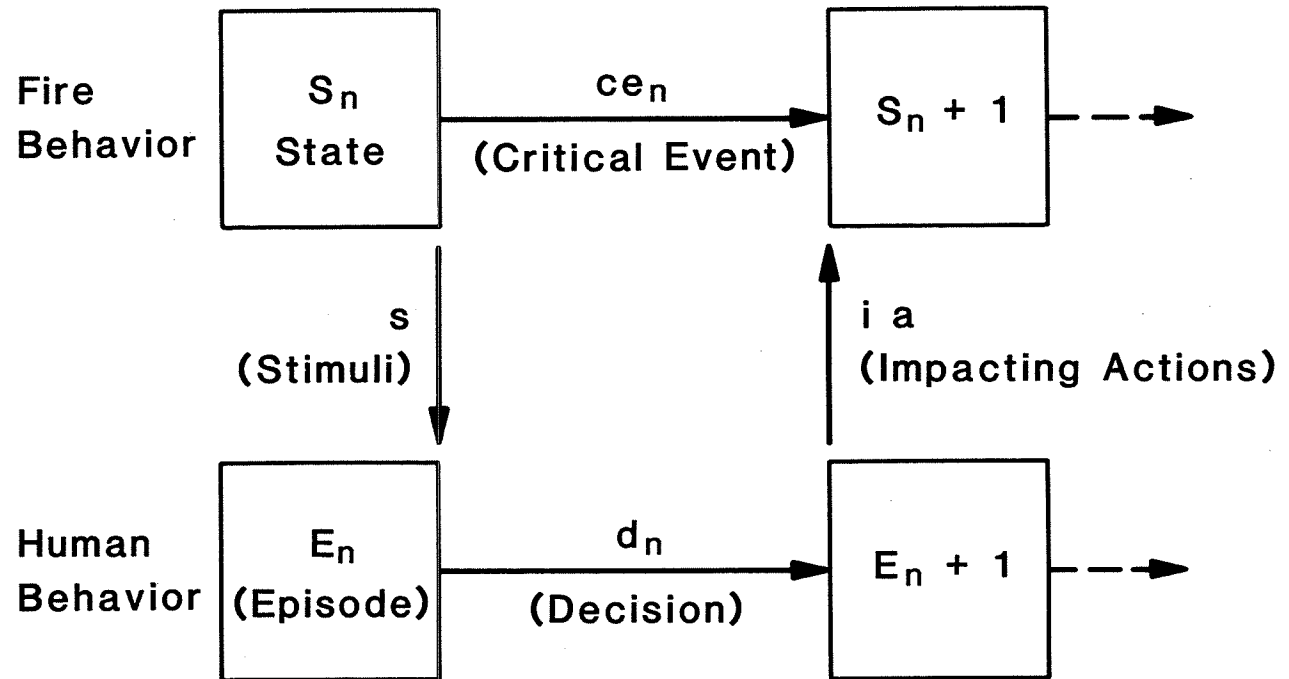

Figure 15: General Model of Interrelationships Between States and Episodes

APPENDIX E

STATUS REPORT ON TRIAL COMPUTERIZATION AND ANALYSIS OF
FIRE INCIDENT DATA

I. CODING

There are three documents relating to coding of the 1970-1977 data:

1. Coding Manual
2. Data Element Dictionary
3. Coding Form

Data in each synopsis of a mine fire in the Allen Corp. of America's "An Annotated Bibliography of Coal Mine Fire Reports" were reduced to 58 distinct data elements as listed in the Data Element Dictionary. Data are coded on a specially prepared coding form. Three 80-character lines are allocated on the coding form for each fire incident. The Coding Manual describes each of the data elements. The right hand four characters in each 80-character line, in effect column positions 77-80, contain the case number of the mine fire for identification and sorting purposes.

Possible problems with the present coding system include:

1. Inconsistent coding of fires started by cutting or welding equipment.
2. Areas of origin presently classified as "Haulageway". Based on suggestions by Bureau of Mines people, it would probably be useful to distinguish 3 types of haulageways:
 - a. track or rail
 - b. tire vehicle or non-rail
 - c. beltway

But note that occasionally track and beltway are the same haulageway.

3. A new data element called "Obstacles to Extinguishment" may be worth coding. This is an important item and seems to be present in enough of the Allen Corp. synopses to merit coding. Some potential coding categories for this data element are:

- Broken or malfunctioning extinguisher (auto or manual)
- Automatic extinguisher - failure to operate
- Heavy smoke
- Unsuccessful attempt to cut off power
- Rapid fire development
- No nearby firefighting apparatus
- Poor training

A useful reference for defining and understanding mining terminology used in the Allen Corp. synopsis is A Dictionary of Mining, Mineral, and Related Terms compiled and edited by Paul W. Thrush of the Bureau of Mines (1968). The NBS library cannot locate its copy but the Bureau of Mines library has a copy available for inter-library loans. A portion of the book was photocopied and is included in the project files.

The Mine Safety and Health Administration has an accident data base. The classification system for several of the data elements in the data base may be useful in this project. Specifically, the injury classification codes which are basically cause classifications and the equipment codes used to identify the object in which a hazardous condition existed are both applicable to the CFR project. Copies of these may be found in the project files.

II. DATA FILES

All of the data files to be described are stored on tape on the NBS Univac 1108. Familiarity with Univac file structure is assumed. The original input data are in an element in file MINES*MINEDATA.DATA70.

The first, second and third lines of data have also been separated in each case and written on separate files (elements) as follows:

MINES*MINEDATA.MINE1	Contains first line (first 80 chars) of each case found in DATA70
----------------------	---

MINES*MINEDATA.MINE2 Contains second line (second 80 chars) of each case found in DATA70

MINES*MINEDATA.MINE3 Contains third line (third 80 chars) of each case found in DATA70

These three separate files (elements) of the original data were created for editing and special output purposes where the other lines of data were not needed or got in the way.

A short ASCII Fortran program, specifically SUBROUTINE SPLIT called by main program FØRM, reads the input data from DATA70, and separates it into three parts which are then written onto three separate files. These were converted from ASCII to FIELDATA code and then copied into file MINEDATA as the elements MINE1, MINE2 and MINE3 shown above.

An ASCII Fortran subroutine CØNCAT was also written to create one 108-character record for each case by extracting selected fields from the original three 80-character lines of data in DATA70. SUBROUTINE CØNCAT is called by main program FØRM. The new 108-character records are written in ASCII code to an input file. The ASCII must be converted to FIELDATA. The data records resulting from executing program CØNCAT are presently in file (element) MINES*MINEDATA.XTRCT70. Programs FØRM, SPLIT and CØNCAT are in file MINES*MINEPRØG.

The contents of the 108-character records stored in XTRCT70 are as follows where "Input Line No." and character positions refer to the Data Element Dictionary:

From Input Line No. 1	Characters 1 through 43, 56 through 60
From Input Line No. 2	Characters 67 through 76
From Input Line No. 3	Characters 1 through 50

File Summary:

<u>File</u>	<u>Element</u>	<u>Description</u>
MINES*MINEDATA.	DATA70	Original input data Three 80-char lines/case
	MINE1	Line 1 from each case in DATA70
	MINE2	Line 2 from each case in DATA70
	MINE3	Line 3 from each case in DATA70
	XTRCT70	One 108-char record/case extracted from DATA 70
MINES*MINEPRØG.	FØFM	Main program to reformat input in DATA70
	SPLIT	Subroutine called by FØRM; Splits DATA70 into 3 parts (MINE1, MINE2, MINE3)
	CØNCAT	Subroutine called by FØRM; extracts data from DATA70 to create 108-char records (XTRCT70)

Documentation for the computer programs and data file listings are in the project files.

III. PRELIMINARY ANALYSIS: SORTS AND CROSS TABULATIONS

The input data have been sorted using NBS Univac utility routine SORTSDF. Tabulations were prepared from some of these sorts and distributed at a meeting with the Bureau of Mines staff working with us on this project. These tabulations are attached to this memo.

Sorts have been done on the following data elements:

1. Duration of Fire by Time of Incident
2. Volatility
3. Mine Name by Date by Time of Incident

4. Area of Origin by Ignition Source
5. Ignition Source by Heat Transfer Mechanism
6. Fuel Item A
7. Extinguishment Agent A by Extinguishment Agent B
8. Action Taken A by Action Taken B
9. Cause by Contributing Factor A by Contributing Factor B
10. Cause by Damage
11. Cause by Production Loss
12. When Detected by How Detected
13. How Detected
14. Heat Transfer Mechanism
15. Fuel Item B
16. Fuel Item C
17. Extinguishment Agent B
18. Extinguishment Agent C
19. Action Taken B
20. Action Taken C
21. Contributing Factor A
22. Contributing Factor B

Two-way cross-tabulations have been done for selected data elements in file MINES*MINEDATA.XTRCT70. The following cross-tabs were run using OMNITAB for the 129 cases representing the mine fires from 1970-1977:

1. Area of Origin vs. General Ignition Source Classification
2. Area of Origin vs. When Detected
3. Area of Origin vs. How Detected
4. General Extinguishment Agent A vs. General Extinguishment Agent B
5. General Extinguishment Agent A vs. When Detected
6. Action Taken A vs. When Detected
7. Action Taken A vs. Action Taken B
8. General Ignition Source Classification vs. General Extinguishment Agent A
9. General Item A vs. General Cause
10. General Cause vs. General Contributing Factor A
11. General Cause vs. General Contributing Factor B
12. When Detected vs. Damage

13. How Detected vs. Damage
14. When Detected vs. Production Loss
15. How Detected vs. Production Loss
16. General Contributing Factor A vs. Damage
17. General Contributing Factor B vs. Damage
18. General Contributing Factor A vs. Production Loss
19. General Contributing Factor B vs. Production Loss

It is hard to tell at this point without having studied the data from the 129 cases whether computerization of the coal mine fire data from 1950-1970 is warranted. Addition of the 1978 and 1979 data would certainly help. The accessibility of the data, the ability to readily retrieve and summarize it and to search for specific scenarios or situations may in itself be a worthwhile enterprise. But, a meaningful statistical comparison of pre- and post-regulatory periods may be very difficult or impossible due to the small number of fires reported since the major changes in regulations/enforcement in the 1970's.