

**A mining research contract report
NOVEMBER 1987**

COAL INTERFACE DETECTOR INVESTIGATION

OFR 1988-6

Contract HO245008
WYLE LABORATORIES

**BUREAU OF MINES
UNITED STATES DEPARTMENT OF THE INTERIOR**

**OFR
88-6**



The views and conclusions contained in this document are those of the authors and should not be interpreted as necessarily representing the official policies or recommendations of the Interior Department's Bureau of Mines or of the U.S. Government.

Reference of specific brands, equipment, or grade names in this report is made to facilitate understanding and does not imply endorsement by the Bureau of Mines.

REPORT DOCUMENTATION PAGE	1. REPORT NO.	2.	3. Recipient's Accession No.
4. Title and Subtitle Coal Interface Detector Investigation		5. Report Date November, 1987	
7. Author(s) Richard P. Cislo		6.	
9. Performing Organization Name and Address Wyle Laboratories Research and Engineering Division 7800 Governors Drive West Huntsville, AL 35807-5101		8. Performing Organization Rept. No. 67704-2	
		10. Project/Task/Work Unit No. 67700	
		11. Contract(C) or Grant(G) No. (C) HO245008 (G)	
12. Sponsoring Organization Name and Address U.S. Department of the Interior Bureau of Mines 2401 E. Street NW Washington, DC 20241		13. Type of Report & Period Covered Final 9/84-11/87	
15. Supplementary Notes		14.	
16. Abstract (Limit: 200 words) The evaluation of the effectiveness of the time domain Coal Interface Detector developed by the General Electric Company under contract HO155120 is the subject of this report. The sensor utilizes differences in the time characteristics of shearer vibrations as sensed by an accelerometer mounted on the ranging arm to discriminate the cutting of coal and rock. Four identical time domain sensors were supplied by the Bureau for field evaluation. The performance of the time domain sensor was evaluated by an extensive field test and data collection program that included four longwall mines and a total of nine mine visits. The intent was to determine the sensor's applicability to a wide range of mining conditions and to document its limitations. Results of the extensive field tests indicate that shearer vibration data processed by GE's time domain signal processing algorithm cannot be used to reliably detect when the cutting drum crossed the coal/rock interface.			
17. Document Analysis a. Descriptors Coal Interface Detector Longwall Horizon Control Machine Vibration Sensor b. Identifiers/Open-Ended Terms c. COSATI Field/Group			
18. Availability Statement Release Unlimited		19. Security Class (This Report) Unclassified	21. No. of Pages 215
		20. Security Class (This Page) Unclassified	22. Price

FOREWORD

This report was prepared by Wyle Laboratories, Huntsville, Alabama, under USBM Contract Number HO245008. The contract was initiated under the Coal Mining Technology Program. It was administered under the technical direction of The Pittsburgh Research Center, with Mr. Michael J. Pazuchanics acting as the Technical Project Officer. Mr. Kent Charles was the Contracting Officer for the Bureau of Mines.

This report is a summary of the work recently completed as part of the contract during the period September 28, 1984, to August 14, 1987. This report was submitted by the authors on November 20, 1987.

The work was performed by the Systems Analysis Department of Wyle Laboratories, Huntsville facility. Significant contributors to the project were Mr. Richard Cislo, Mr. Thomas Coffin, Mr. Wallace Morrow, Mr. Mark Pettitt, and Mr. Steve Sargent.

Appreciation is given to the following individuals: Mr. Keith Seiber of Emway Resources, Mr. Timothy Burrage of the Jim Walter Resources Number 3 Mine, Mr. Ron Hughes of Kaiser Coal's Sunnyside Mine, and Mr. Phil Bradford of the North River Energy Corporation. In addition, we thank all of the members of the longwall crews who assisted us in the field tests.

Respectfully submitted,



Richard P. Cislo
Project Manager/Principal Investigator

TABLE OF CONTENTS

	<u>Page</u>
Report Documentation Page	3
Foreword	4
List of Figures	6
List of Tables	8
Summary	10
I. Introduction	13
II. Background	15
III. Experimental Program Definition	16
IV. Equipment Acquisition Checkout	25
V. Data Collection	29
VI. Data Reduction and Analysis	34
Jim Walter Resources No. 3 Mine	34
Emway Resources Emerald No. 1 Mine	43
Kaiser Coal's Sunnyside Mine	52
North River Energy Corporation	61
VII. Factorial Analyses	70
Percentage of Cutting Signals Overall	75
Percentage of Cutting Signals When Cutting Rock	92
Percentage of Cutting Signals When Cutting Coal	105
VIII. Conclusions and Recommendations	116
Appendix A: Data Acquisition System	117
Appendix B: Operating Characteristics of Participating Mines	125
Appendix C: Schmidt Test Hammer Operating Instructions	127
Appendix D: Coal and Rock Density Measurements	131
Appendix E: Coal Interface Detector Evaluation Program	133
Appendix F: Results of Initial CID Evaluation Program	171
Appendix G: Example of the Computational Procedure Used for Factorial Experimentation	181
Appendix H: Computer Output of the Percentage of Cutting Signals Overall	187
Appendix I: Computer Output of the Percentage of Rock Cutting Signals	199
Appendix J: Computer Output of the Percentage of Coal Cutting Signals	209

LIST OF FIGURES

		<u>Page</u>
1	Coal Interface Detector Data Acquisition Diagram	18
2	Typical Instrumentation System Locations	19
3	Data Presentation Format.	23
4	Block Diagram of the Coal Interface Detector	26
5	Experimental Setup for CID Operational Checkout	27
6-7	Primary Data Plots for the Jim Walter Resources No. 3 Mine	35-36
8	Percentage of Correct and Incorrect Coal and Rock Cutting Signals (Analog Signal <1), Jim Walter Resources No. 3 Mine	39
9	Percentage of Correct and Incorrect Coal and Rock Cutting Signals (Analog Signal <3), Jim Walter Resources No. 3 Mine	39
10	Percentage of Correct and Incorrect Coal and Rock Cutting Signals (Analog Signal <5), Jim Walter Resources No. 3 Mine	40
11	Percentage of Correct and Incorrect Coal and Rock Cutting Signals (Analog Signal <8), Jim Walter Resources No. 3 Mine	40
12-13	Primary Data Plots for the Emway Resources, Emerald No. 1 Mine	44-45
14	Percentage of Correct and Incorrect Coal and Rock Cutting Signals (Analog Signal <1), Emway Resources, Emerald No. 1 Mine	47
15	Percentage of Correct and Incorrect Coal and Rock Cutting Signals (Analog Signal <3), Emway Resources, Emerald No. 1 Mine	47
16	Percentage of Correct and Incorrect Coal and Rock Cutting Signals (Analog Signal <5), Emway Resources, Emerald No. 1 Mine	48
17-18	Primary Data Plots for Kaiser Coal's Sunnyside Mine	53-54
19	Percentage of Correct and Incorrect Coal and Rock Cutting Signals (Analog Signal <1), Kaiser Coal's Sunnyside Mine	56
20	Percentage of Correct and Incorrect Coal and Rock Cutting Signals (Analog Signal <3), Kaiser Coal's Sunnyside Mine	56
21	Percentage of Correct and Incorrect Coal and Rock Cutting Signals (Analog Signal <5), Kaiser Coal's Sunnyside Mine	57
22-23	Primary Data Plots for the North River Energy Corporation Mine.	62-63
24	Percentage of Correct and Incorrect Coal and Rock Cutting Signals (Analog Signal <1), North River Energy Corporation Mine	65
25	Percentage of Correct and Incorrect Coal and Rock Cutting Signals (Analog Signal <3), North River Energy Corporation Mine	65
26	Percentage of Correct and Incorrect Coal and Rock Cutting Signals (Analog Signal <5), North River Energy Corporation Mine	66
27a	Profiles of Each of the Levels of Analog Signal for the Levels of Depth of Cut at Hardness Ratio Level 1 for the Percentage of Cutting Signals Overall	80
27b	Profiles of Each of the Levels of Analog Signal for the Levels of Depth of Cut at Hardness Ratio Level 2 for the Percentage of Cutting Signals Overall	80
27c	Profiles of Each of the Levels of Analog Signal for the Levels of Depth of Cut at Hardness Ratio Level 3 for the Percentage of Cutting Signals Overall	81
27d	Profiles of Each of the Levels of Analog Signal for the Levels of Depth of Cut at Hardness Ratio Level 4 for the Percentage of Cutting Signals Overall	81

LIST OF FIGURES (Concluded)

		<u>Page</u>
28	Profiles of Each of the Levels of Analog Signal for the Levels of Velocity for the Percentage of Cutting Signals Overall	86
29a	Percentage of Correct and Incorrect Coal and Rock Cutting Signals (Analog Signal < 1), All Data Points	90
29b	Percentage of Correct and Incorrect Coal and Rock Cutting Signals (Analog Signal < 3), All Data Points	90
29c	Percentage of Correct and Incorrect Coal and Rock Cutting Signals (Analog Signal < 5), All Data Points	91
30a	Profiles of Each of the Levels of Analog Signal for the Levels of Depth of Cut for the Percentage of Cutting Signals When Cutting Rock	97
30b	Profiles of Each of the Levels of Analog Signal for the Levels of Hardness Ratio for the Percentage of Cutting Signals When Cutting Rock	97
30c	Profiles of Each of the Levels of Analog Signal for the Levels of Velocity for the Percentage of Cutting Signals When Cutting Rock	100
31a	Percentage of Correct and Incorrect Rock Cutting Signals (Analog Signal ≥ 5), All Data Points	103
31b	Percentage of Correct and Incorrect Rock Cutting Signals (Analog Signal ≥ 3), All Data Points	103
31c	Percentage of Correct and Incorrect Rock Cutting Signals (Analog Signal ≥ 1), All Data Points	104
31d	Percentage of Correct and Incorrect Rock Cutting Signals (Analog Signal ≥ 0), All Data Points	104
32a	Profiles of Each of the Levels of Analog Signal for the Levels of Hardness Ratio for the Percentage of Cutting Signals When Cutting Coal	110
32b	Profiles of Each of the Levels of Analog Signal for the Levels of Velocity for the Percentage of Cutting Signals When Cutting Coal	110
33a	Percentage of Correct and Incorrect Coal Cutting Signals (Analog Signal < 1), All Data Points	114
33b	Percentage of Correct and Incorrect Coal Cutting Signals (Analog Signal < 3), All Data Points	114
33c	Percentage of Correct and Incorrect Coal Cutting Signals (Analog Signal < 5), All Data Points	115

LIST OF TABLES

		<u>Page</u>
1	CID Operational Checkout Instrumentation List	28
2	Summary of the Geology Encountered During Mine Testing	30
3	Percentage of Occurrence of Analog Signal for Each Primary Factor, Jim Walter Resources No. 3 Mine	38
4	Percentage of Occurrence of Each Level of Analog Signal for Each Level of Primary Factor, Jim Walter Resources No. 3 Mine	41-42
5	Percentage of Occurrence of Analog Signal for Each Primary Factor, Emway Resources, Emerald No. 1 Mine	46
6	Percentage of Occurrence of Each Level of Analog Signal for Each Level of Primary Factor, Emway Resources, Emerald No. 1 Mine	50-51
7	Percentage of Occurrence of Analog Signal for Each Primary Factor, Kaiser Coal's Sunnyside Mine	55
8	Percentage of Occurrence of Each Level of Analog Signal for Each Level of Primary Factor, Kaiser Coal's Sunnyside Mine	59-60
9	Percentage of Occurrence of Analog Signal for Each Primary Factor, North River Energy Corporation	64
10	Percentage of Occurrence of Each Level of Analog Signal for Each Level of Primary Factor, North River Energy Corporation	68-69
11	Example of an Analysis of Variance (ANOVA) Table Format (Three- Factor Experiment)	71
12	Analysis of Variance Table (ANOVA) for the Percentage of Cutting Signals Overall	77
13	Summary Table for the Three-Factor Interaction Involving Analog Signal, Depth of Cut, and Velocity for the Percentage of Cutting Signals Overall	79
14	Freq. for the Factors Involved in the Coal and Rock Cutting Factorial Experiment	82
15a	Summary of the Simple Effects of Depth of Cut (B) on Analog Signal (A) at Level 1 of the Hardness Radio (C)	82
15b	Summary of the Simple Effects of Depth of Cut (B) on Analog Signal (A) at Level 2 of the Hardness Radio (C)	82
15c	Summary of the Simple Effects of Depth of Cut (B) on Analog Signal (A) at Level 3 of the Hardness Radio (C)	83
15d	Summary of the Simple Effects of Depth of Cut (B) on Analog Signal (A) at Level 4 of the Hardness Radio (C)	83
16	Summary Table for the Two-Factor Interaction Involving Analog Signal and Velocity for All Data Points.	85
17	Freq. for the Factors Involved in the Coal and Rock Cutting Factorial Experiment	87
18	Summary of the Simple Effects of Velocity (D) on Analog Signal (A) for Coal and Rock Cutting	87
19	Percentage of Occurrence of Analog Signal for Each Primary Factor, Coal and Rock Cutting (All Data Points)	89
20	Analysis of Variance Table (ANOVA) for the Percentage of Cutting Signals When Cutting Rock	95
21a	Summary Table for the Two-Factor Interaction Involving Analog Signal and Depth of Cut for the Rock Cutting Data Points	96

LIST OF TABLES (Concluded)

		<u>Page</u>
21b	Summary Table for the Two-Factor Interaction Involving Analog Signal and Hardness Ratio for the Rock Cutting Data Points	96
21c	Summary Table for the Two-Factor Interaction Involving Analog Signal and Velocity for the Rock Cutting Data Points	96
22	Freq. for the Factors Involved in the Rock Cutting Factorial Experiment	98
23a	Summary of the Simple Effects of Depth of Cut (B) on Analog Signal (A)	98
23b	Summary of the Simple Effects of Hardness Ratio (C) on Analog Signal (A)	99
23c	Summary of the Simple Effects of Velocity (D) on Analog Signal (A).	99
24	Percentage of Occurrence of Analog Signal for Each Primary Factor, Rock Cutting (All Data Points)	102
25	Analysis of Variance Table (ANOVA) for the Percentage of Cutting Signals When Cutting Coal	108
26a	Summary Table for the Two-Factor Interaction Involving Analog Signal and Hardness Ratio for Coal Cutting	109
26b	Summary Table for the Two-Factor Interaction Involving Analog Signal and Velocity for Coal Cutting	109
27	Freq. for the Factors Involved in the Coal Cutting Factorial Experiment	111
28a	Summary of the Simple Effects of Hardness Ratio (C) on Analog Signal	111
28b	Summary of the Simple Effects of Velocity (D) on Analog Signal (A).	111
29	Percentage of Occurrences of Analog Signal for Each Primary Factor, Coal Cutting (All Data Points)	113
C1	Base Results, Percentage of Cutting Signals in Each Factorial Condition When Cutting Both Coal and Rock	190
D1	Total Number of Data Points in Each Factorial Condition When Cutting Both Coal and Rock	194
C2	Base Results, Percentage of Cutting Signals in Each Factorial Condition When Cutting Rock.	202
D2	Total Number of Data Points in Each Factorial Condition When Cutting Rock.	205
C3	Base Results, Percentage of Cutting Signals in Each Factorial Condition When Cutting Coal	212
D3	Total Number of Data Points in Each Factorial Condition When Cutting Coal	214

SUMMARY

The object of this report was to determine the effectiveness of the time domain Coal Interface Detector (CID) developed by the General Electric Company under Contract HO155120. This detector indicates amplitude modulation levels in the filtered vibration signal and was shown by laboratory testing to be relatively independent of machine design.

The performance of the time domain sensor was evaluated by an extensive field test and data collection program. The intent was to determine the detector's applicability to a wide range of mining conditions and to document its limitations. Four longwall mines participated in the data collection program. A total of nine visits were taken to the Emway Resources, Emerald No. 1 Mine located in Waynsburg, Pennsylvania; the Jim Walter Resources No. 3 Mine located in Adger, Alabama; Kaiser Coal's Sunnyside Mine located in Sunnyside, Utah; and to the North River Energy Corporation Mine located in Berry, Alabama.

The variance in the geological and operational conditions between the participating minesites provided sufficient data for a complete CID performance evaluation. The geologic condition of primary interest at each minesite was the coal/rock hardness ratio. The hardness ratio is the source of the sensor discriminant. The hardness ratios ranged from 0.2 to 1.2 at the participating minesites.

To investigate the effect of different types of shearing machines on CID performance, each participating mine had a different type of shearing machine. The types of shearers instrumented at the participating minesites were the Anderson Maver 500, the Eickhoff 150-2L, the JOY 1LS, and a MISUI Mike.

The instrumentation system consisted of three metal enclosures. One metal enclosure contained four accelerometers and was mounted near the cutter drum on the shearer ranging arm. The accelerometer that feeds the input to the CID is mounted in this enclosure. A second metal enclosure containing three accelerometers was mounted on the shearer chassis. These accelerometers plus the three accelerometers mounted near the cutter drum are referred to as survey accelerometers and were mounted on

the shearing machine to provide additional data for future CID development work. The third enclosure contained the CID electronics.

A TEAC Model HR-30 Type E seven-channel data cassette recorder was used underground to record the signals generated by the equipment described above. The recording format was mixed with five direct record channels and two FM wide-band group I channels. This format allows 50 Hz to 8 kHz bandwidth for the direct record channels and DC to 1.25 kHz bandwidth for the FM channels.

Data was taken during a production shift as the shearer traversed the face. The shearer operator performed his function in a normal manner. As the instrumented shearer drum axis crossed each shield, the shield number was recorded on the voice channel of the tape recorder. The second member of the data acquisition team maintained a direct line of site with the instrumented drum and noted the depth of cut into rock along the longwall face. Data was collected over at least three cutting passes during each mine visit.

Prior to the start of the production shift, an attempt was made to measure the coal and rock hardness values with a Schmidt Concrete Test Hammer (Type N) at each shield location. Coal and rock samples were also taken at each of the hardness testing locations. The samples were used to determine the bulk density of the coal and rock strata.

The acquired data was divided into two categories, primary and secondary. The primary data are the CID analog signal and the longwall face condition data (i.e., coal/rock hardness ratio, depth of cut into rock, and shearer velocity). The secondary data are the recorded survey accelerometer data that can be used in the laboratory along with the longwall face condition data to evaluate other CID discriminant schemes.

The test program generated over 2,400 data vectors. This large amount of data contained a sufficient amount of variable conditions to support the analysis of the data as a factorial experiment. A factorial experiment is actually a set of experiments in which the individual and joint effects of several variables and combinations of the values, or levels of these variables, are systematically studied.

The results of the factorial experiment revealed that as the magnitude of the velocity increased, the magnitude of the analog signal increased. This may be due to the cutting bits imparting a greater force of impact on the cutting surface at the higher velocities. It appears that the depth of cut into rock and coal/rock hardness ratio had no significant effect on the level of analog signal.

An analysis of the percentage of correct cutting signals obtained from the CID reveals that the CID was effective approximately 50 percent of the time.

It can be concluded from the results of the factorial experiment and the analysis of correct cutting signals that the shearer vibration data processed by GE's time domain signal processing algorithm cannot be used reliably to detect when the cutting drum crossed the coal/rock interface.

I. INTRODUCTION

There is a continuing slow and steady trend toward longwall mining in the United States. Longwall faces accounted for approximately 20 percent of the U.S. underground production. However there was a decline in the number of active faces in the U.S. in 1986 due to the depletion of reserves and economics.

Several problems unique to U.S. longwalls, such as multi-entry systems, health and safety regulations, and mining conditions, must be overcome so that longwalls can provide the necessary productivity to remain cost effective. Longwalls are expensive. For cost effectiveness, high productivity and production rates must be achieved. Additional research and development are needed to overcome the limitations to production and productivity.¹

The U.S. Bureau of Mines is encouraging the American coal mining industry to employ longwalling more widely. Among its efforts is a program to automate longwall mining to a cost-effective level that can extend, amplify, and even sharpen human perception by using electronic sensors to provide additional and more quantitative operating information, relieve the monotony of repetitive operations, and permit monitoring from safer and more comfortable remote locations.²

In the past, the government funded a number of projects in support of a program to improve resource recovery and productivity through automation of existing mining machines. Using that experience as a base, the BOM now plans to explore the potential of advanced sensor technology to meet the requirements of tomorrow's mining systems.

In the past, one lesson learned is that coal interface detectors (CID) are a weak link in all the advanced extraction systems studied. In such systems, these devices are required to determine when the machine's cutting drum is operating at the desired

¹ Longwall-Shortwall Mining State-of-the-Art, ed. Raja V. Ramani (New York: The American Institute of Mining, Metallurgical, and Petroleum Engineers, Inc., 1981) p. vii.

² Normen R. Kuchar; Robert V. Klint and Bernard Darrel, "A Vibration Sensor for Horizontal Control in Automated Longwall Mining," NTIS FE/9015-1, October 1977, p. 7.

upper and lower coal horizons. A number of CID (nucleonic, radar, acoustic, natural gamma radiation, etc.) investigations have been conducted to date; and in each case, the device showed some merit in a specific mining environment but was not applicable in the general case.

Horizon control on ranging drum shearers is presently performed by operators who follow the machine and adjust the cutting drum position, using visual observation, cutting noise characteristics, and the "feel" of the shearer as indicators of the material being cut.³ The fact that qualitative sound and vibration characteristics are presently used by the shearer operators to detect the coal/rock interface led to the postulation that a vibration transducer and subsequent mechanical signature analysis could be used for automatic interface detection.⁴

Two types of vibration sensors were developed under Contract HO155120, "Vibration Sensor for Horizon Control in Automated Longwall Mining," by General Electric's Corporate Research and Development Division. The first type (frequency domain) operates on vibration amplitudes at resonant frequencies and was found to be accurate and sensitive but required fine tuning for each machine model. The second type (time domain) looks at amplitude modulation levels in the vibration signal and is relatively independent of machine design. The latter unit was laboratory tested using a limited number of data tapes (longwall shearer vibration signals recorded on a magnetic tape). A detailed description of the time domain sensor is given in Appendix A. The potential and limitations of the time domain sensor had not been fully explored.

On September 28, 1984, the U.S. Bureau of Mines awarded a contract entitled "Coal Interface Detector Investigation" to Wyle Laboratories. The objective of this program is to evaluate the effectiveness of the time domain interface detector (CID) developed under Contract HO155120, "Vibration Sensor for Horizon Control in Automated Longwall Mining." The evaluation of the performance of the time domain sensor is the subject of this report.

³Ibid., p. 8.

⁴ Ibid.

II. BACKGROUND

The program objectives were accomplished through four distinct program phases.

- Phase I Experimental Program Definition
- Phase II Equipment Acquisition and Checkout
- Phase III Data Collection
- Phase IV Data Reduction and Analysis

This report will be structured in accordance with the accomplishment of each phase.

III. EXPERIMENTAL PROGRAM DEFINITION

The performance of the time domain sensor was evaluated by an extensive field test and data collection program. The program included four longwall mines and a total of nine visits. The intent here was to determine the applicability of the CID to a wide variety of conditions and to document its limitations. The results of this investigation were used in assessing whether the sensor is a viable coal interface detector for future automated systems.

1.0 MINE SELECTION

Four longwall mines were sought for participation in the data collection program. Certain geologic and operational conditions were required to provide sufficient data for a relatively complete CID performance evaluation. The participants included Jim Walter Resources No. 3 Mine located in Adger, Alabama; North River Energy Corporation located in Berry, Alabama; Emway Resources, Emerald No. 1 Mine located in Waynesburg, Pennsylvania; and Kaiser Coal's Sunnyside Mine located in Sunnyside, Utah. The geologic condition of primary interest in each mine was the coal/rock hardness ratio. The hardness ratio is the source of the sensor discriminant. It was desirable for the sensor evaluation, therefore, to select longwall faces that collectively and/or individually represent a wide coal/rock hardness ratio range.

Since the sensor is designed to discriminate when the cutter drum has crossed the coal/rock interface, each participating mine has an operational goal of leaving no roof coal but cutting little rock. The CID is not suitable for mines that seek to leave several inches of roof coal.

Finally, to investigate the effect of shearing machine type on CID performance, each participating mine has a different shearing machine. The mining conditions at each participating mine are given in Appendix B.

2.0 MEASUREMENT PLAN

The data required for complete CID evaluation was obtained without inhibiting coal production. Several visits were made to each participating mine to obtain data at various points along the panel length. The data was collected by a two-man team using the instrumentation system described in Appendix A. After the first visit to

Emway Resources, which occurred in September 1985, the instrumentation system was modified. Originally, a Bell and Howell, Mars 2000, 14-channel FM tape recorder enclosed in an explosion-proof box was used. This system proved to be a disadvantage due to its weight (approximately 300 pounds, including power supply) and to the clearance problems posed between the shearer body and the shields. An intrinsically safe seven-channel TEAC HR-30E tape recorder was purchased and used to record data for the remaining mine visits. The procedure used to collect data is outlined below.

A. Before entering the mine:

1. Prepare documentation.
2. Check instrumentation readiness.
 - Check charge on the CID.
 - Check operation of the tape recorder.
 - Check the accelerometer power supplies.

B. At longwall face and during maintenance shift:

1. Mount the data collection system.

During the first mine visit, several mounting lugs were welded to the shearing machine. These lugs, in most cases, remained in place for all of the data collection visits. A block diagram of the instrumentation that was mounted on the shearers is shown in Figure 1. The system consisted of three separate metal enclosures. Two enclosures contained accelerometers. One enclosure contained the coal interface detector electronics. Typical mounting positions of these instruments are shown in Figure 2. The complete data measurement system specifications are given in Appendix A.

2. Number the shields.

Check to see if the shields are adequately marked.

3. Take coal and rock hardness measurements.

A Schmidt Concrete Test Hammer (Type N) was used to measure the coal and rock hardness along the panel width. The position of the measurements along the face were defined by the corresponding shield number.

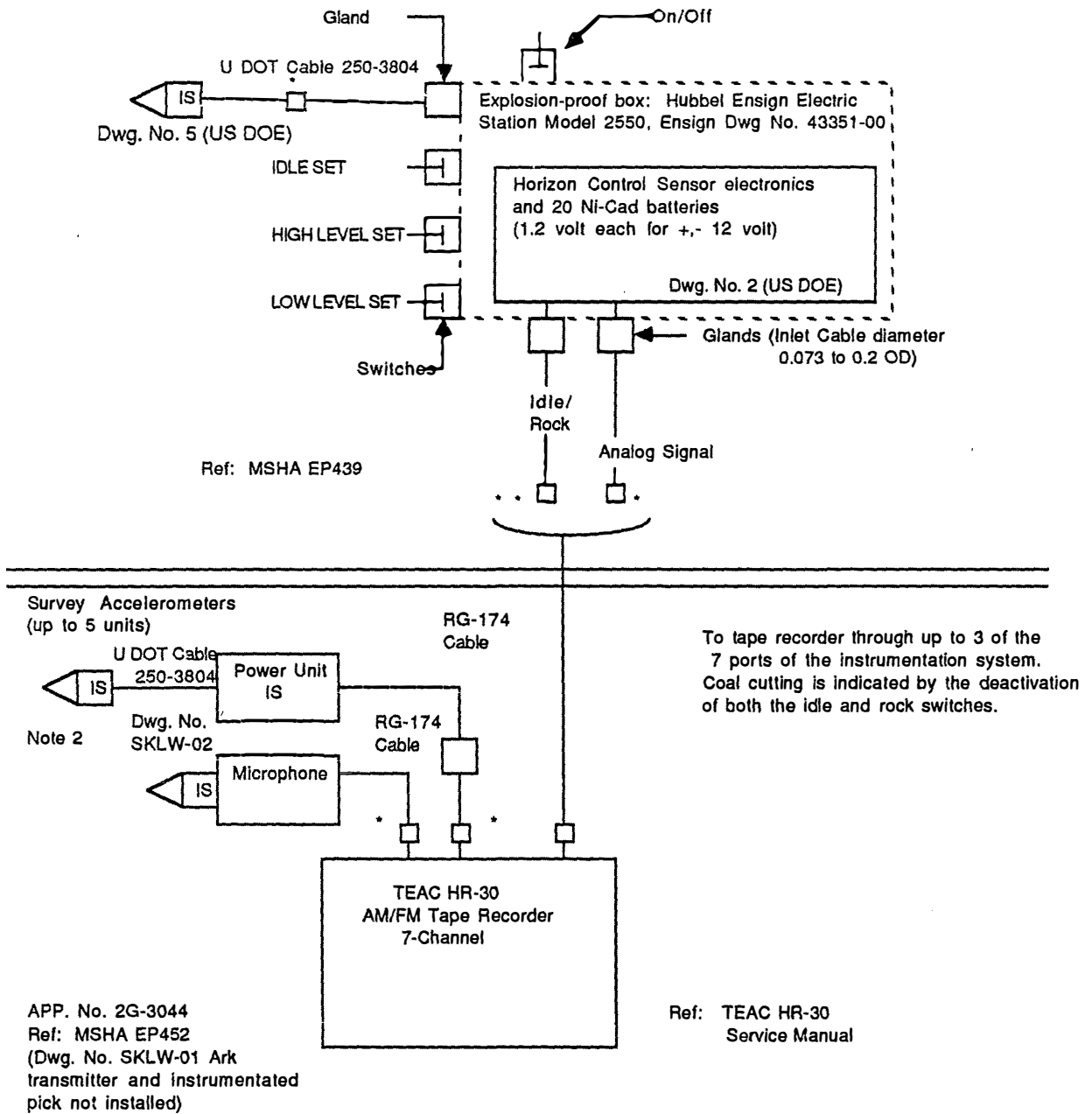

*BNC cable connectors

**Binch-Jones Multiple Connector. Pat. No. 2980881

Wyle Laboratories
Dwg. No. CIDS ALT
Date: 3/17/86

NOTES:

- (1) Unless otherwise indicated, all reference drawings are those of Wyle Laboratories. All referenced Dwgs. filed at MSHA-A&CC.
- (2) Total No. of survey accelerometers plus microphone does not exceed 6.
- (3) All cables must be installed in accordance with applicable requirements in 30 CFR Part 18.
- (4) No changes to these circuits may be made without approval of MSHA.

Figure 1. Coal Interface Detector Data Acquisition System Diagram

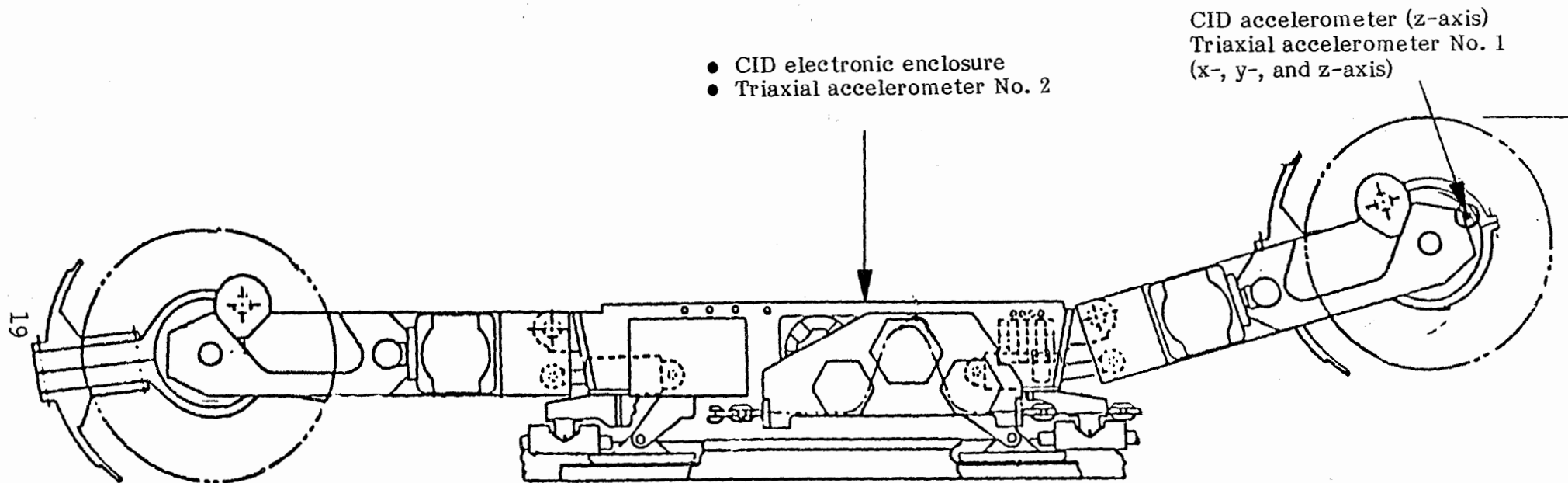

FIGURE 2. Typical Instrumentation System Locations

An attempt was made to take ten measurements on each of the strata (top, coal seam, bottom) at each shield location. Sometimes this procedure was precluded by the presence of water, by the relative position of the shields and the pan line, or by the production schedule.

The test hammer would not register a reading for highly fractured coal. In this case, hardness readings were performed on a large sample of coal appropriated from the face at the shield location.

The measurements at each location consumed approximately ten minutes.

4. Collect coal and rock samples.

Coal and rock samples were collected at each hardness test location. Again, the locations of the samples were identified by the shield number. The samples were used to establish the density of the coal and rock (see Appendix D).

C. At Longwall face and during production shift:

1. Take measurements during cutting passes.

The "half face technique" was the most common cutting maneuver used at the participating minesites. At the beginning of the cycle, the shearer is at the headgate with the lead drum raised for the principal cutting action and the tail drum is at the floor level to cut the lower seam portion and to load most of the material. The sections of the conveyor toward the tailgate side of the shearer are pushed close to the face. The shearer deadheads to the point where the conveyor is close to the face. Then, following the contour of the conveyor, the shearer begins sumping into the coal. After the full cut sump has been achieved, the shearer continues to cut at lower speed until it reaches the tailgate. As soon as the lead drum cuts out into the tailgate, the lead drum is lowered while the tailgate drum is raised. While this action is occurring, the conveyor sections to the headgate side of the shearer are pushed close to the face and the chucks are advanced. Then the reverse action is employed to cut towards the headgate side of the longwall face.

Data was taken as the shearer transversed the face. The shearer operator performed his function in a normal manner. As the axis of the instrumented shearer drum crossed each shield, the shield number was recorded on the VOICE channel of the tape recorder. The second member of the measurement team accompanied the worker advancing the shields during the earlier data acquisition visits. As each shield was advanced, the depth of cut into rock was noted on an after-the-fact basis. A direct line of sight with the instrumented cutting drum was not maintained from this position. The depth of cut noted was, at times, erroneous due to large pieces of the roof strata falling out ahead of the cutter head action. Following these early visits, this procedure was changed. The member in charge of depth-of-cut measurements was stationed in advance of the cutting action where a direct line of sight was attained with the instrumented cutting drum. A more accurate determination of depth of cut into rock was attained from this new location. This team member was also able to converse with the shearer operator, who defined the extent of the depth of cut into the bottom stratum. Data was collected on a minimum of three cutting passes in this manner.

2. Remove measurement system.

During a natural interruption of operations, such as a lunch break, or during a mechanical failure, the measurement system (i.e., CID, tape recorder, sound level meter) was removed from the shearing machine and carried to the headgate. Once data collection activities had been completed, the measurement system was removed at the headgate area during a planned maintenance period (i.e., changing bits). The system was removed from the shearer in less than ten minutes.

- D. After exiting mine:

1. Check documentation.

The documentation was checked for completeness.

2. Check the charge remaining on the CID.

3.0 DATA ANALYSIS

A large amount of data was generated by the experimental program. Several variables were monitored on over 35 shearer passes. This section describes the data analysis method used to draw, from the mass of raw data, statistically valid answers to the question, "How effective is the CID sensor?" and "How do the measured variables alter the effectiveness?".

The acquired data can be divided into two categories, primary and secondary. The primary data are the CID analog signal and the longwall face condition data. This data was used to evaluate the effectiveness of the CID. The secondary data are the recorded accelerometer signals. This data along with longwall face condition data can be used in the laboratory to evaluate other CID discriminant schemes.

3.1 Primary Data Analysis

The primary data of each shearer pass was reduced to the form shown in Figure 3. This form correlates all the data according to the longwall face position at which it occurred. The data was also digitized to the limit of data resolution and stored on a computer data file to allow computerized statistical analysis of the combined data.

The limit of data resolution concept is important to the formulation of a reasonable data reduction plan. While the data recorded on FM tape is continuous, the face condition data could only be recorded at a number of discrete points. In addition, the correlation of the CID and vibration data with the longwall face condition data is only valid at the shield count marks. Accurate shield count was limited to one-half shield resolution. Hence, given a shield width of 5 feet and a panel width of 500 feet, the cutting pass data could be digitized into about 200 valid data points. The several variables measured at each point constitute a data vector. The test program generated 2,477 data vectors. This large amount of data contains a sufficient amount of variable conditions to support the analysis of the data as a factorial experiment.

A factorial experiment is actually a set of experiments in which the individual and joint effects of several variables and combinations of the values, or levels of these variables, are systematically studied. In the particular case at hand, the conditions and result at each data point can be interpreted as an "experiment." The several

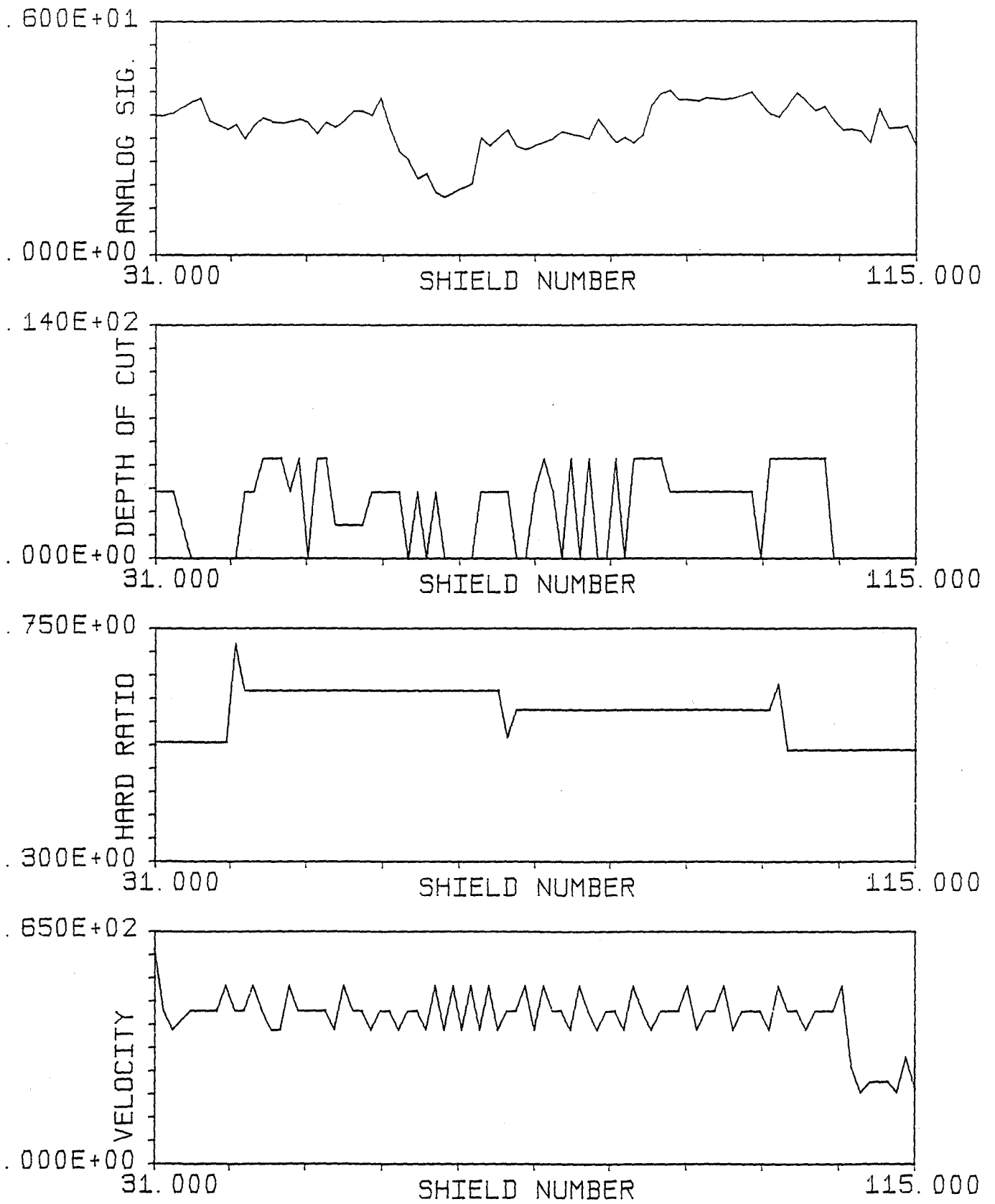

J. W. #3 VIS. #3 PASS#3 H TO T CUTTING
 DATASET 22

FIGURE 3. Data Presentation Format

variables (or factors) act on the CID sensor at each point to produce an analog signal. The analog signal is checked against an assigned coal cutting band (an important, independent variable) to yield the cutting coal or cutting rock signal. A check of the actual cutting condition at the data point gives the success or failure of the CID at that data point (and with the associated variable conditions). If the factors (variables) and the several levels (or values) associated with each factor are correctly chosen, a significant number of data points will be associated with each factorial condition. The measure of the CID effectiveness (the result of the experiment) can then become the percentage of correct cutting signals.

Organization of the mass of data in this manner yields two important results. First, the CID effectiveness is quantified for each factorial condition (or specific set of variable conditions). Second, a statistical analysis of variance can be conducted to estimate the significance of each variable's effect on the CID effectiveness.

A computer program was written in Fortran 77 (Microsoft V3.2) to support this data analysis procedure. The program can be run on a IBM-compatible computer. It allows creation of the data files, definition of the factorial experiment (variables and levels of each variable to be considered), and the execution of the statistical analysis. Three measures of CID effectiveness may be chosen by the program user. They are the percentage of cutting signals overall, the percentage of coal cutting signals, and the percentage of rock cutting signals. The results of this program are used in the Data Analysis section of the report. The program is fully described in Appendix E. A printout of all data files is shown in Appendix A of the Supplement to the Final Report.

3.2 Secondary Data Analysis

The vibration signals from the survey accelerometers were recorded on FM tape. The data can later be used as input for a bench test of other vibration CIDs. Analysis of the vibration signals was not funded under the program scope of work.

IV. EQUIPMENT ACQUISITION AND CHECKOUT

Four Coal Interface Detectors, two Bruel and Kjaer Model 4344 accelerometers, and two battery chargers were received by Wyle Laboratories from the Bureau of Mines in October of 1984. By November of 1984, a laboratory procedure to check the operational condition of the CID's was developed. This procedure is described below.

Several different tests were required to evaluate the operation of all functions of the CID electronics. Figure 4 gives a block diagram of the CID and also indicates by test number the method used to evaluate the performance of each function. Figure 5 shows the test setup, and Table 1 lists the instrumentation needed to perform the required tests. The accelerometer signal input to the CID was simulated by a capacitor. In all tests, the input charge and voltage were maintained at levels comparable to the real accelerometer input expected (maximum of 150 mV and 150 pC). The results of the initial evaluation procedure performed on the CID's in November of 1984 are shown in Appendix F.

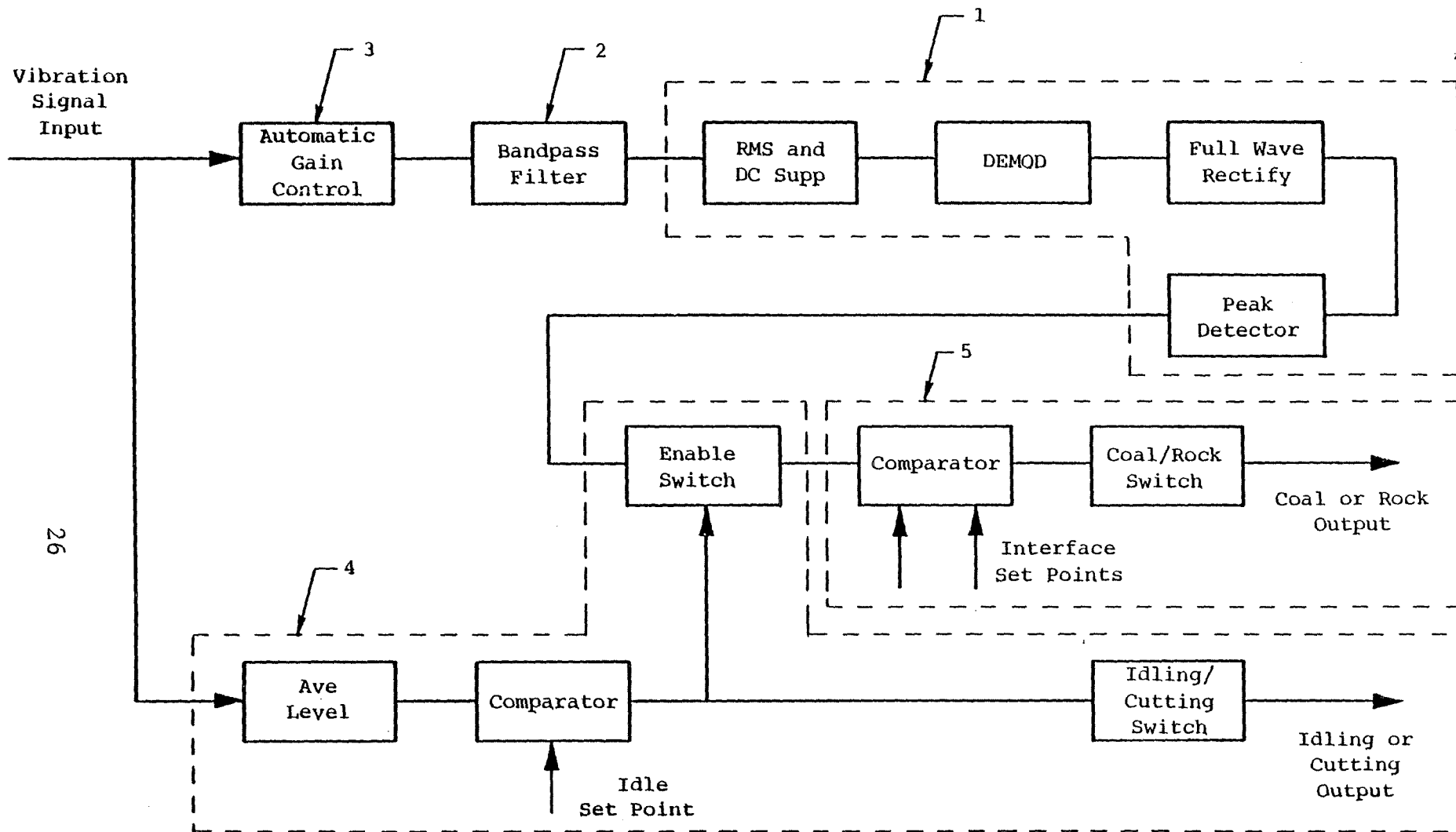

26

FIGURE 4. Block Diagram of Coal Interface Detector

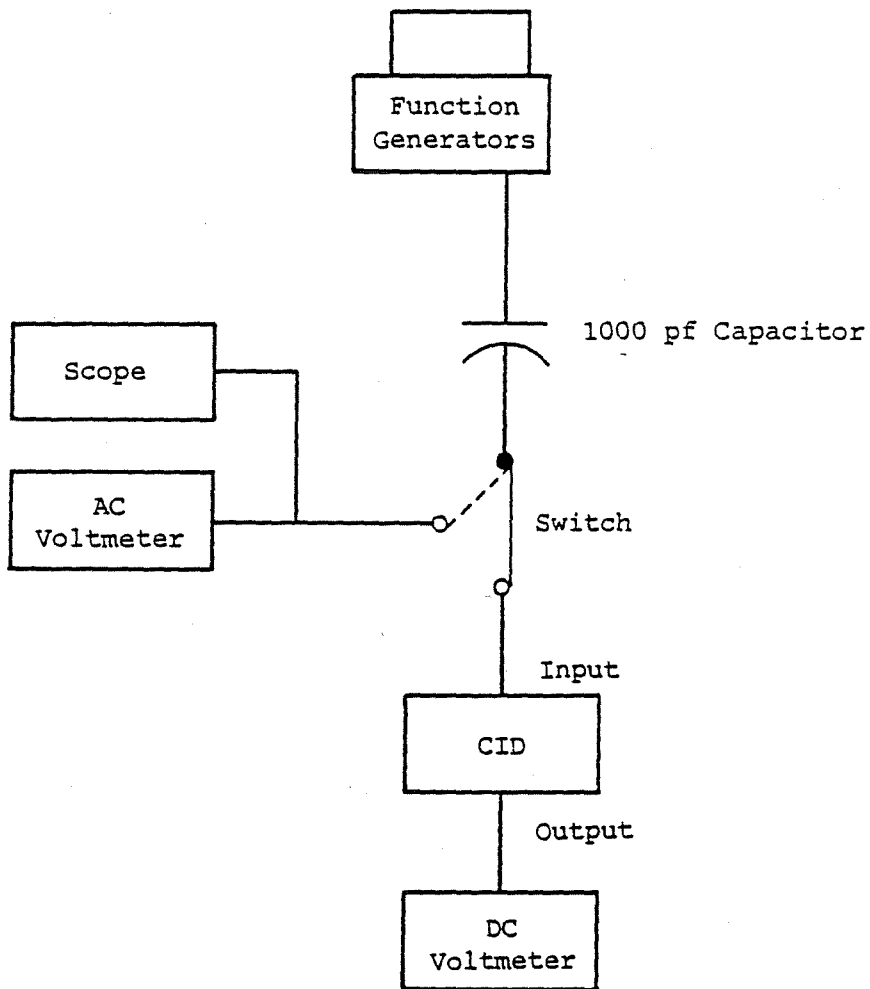

FIGURE 5. Experimental Setup for CID Operational Checkout

TABLE 1. CID Operational Checkout Instrumentation List

1. Function generators
 - a) Dynascan Corp. 3020 Sweep/function generator #W100058, calibrated 11-15-84, calibration due 5-15-85.
 - b) Hewlett-Packard 311A Function Generator #W0892 calibrated 8-22-84, calibration due 2-22-85.
2. Voltmeters
 - a) Keithley Digital Multimeter, model 178 DMM #W11313, calibrated 9-21-84, calibration due 3-31-85.
 - b) Hewlett Packard Digital Multimeter, model 3465A, #W11184, calibrated 9-28-84, calibration due 3-28-85.
3. Oscilloscope
 - a) Gould 20 MHz Digital Storage Scope OS1420 #W101050, calibrated 7-28-84, calibration due 1-20-85.

V. DATA COLLECTION

All the data was recorded from four different double ranging drum shearers in four mines and four different coal seams (see Table 2). This broad diversity of shearers and seam parameters provided a good data base for sensor evaluation. The physical characteristics of the shearers are shown in Appendix B.

The least friable coal tested was that in the North River Energy Corporation Mine located in Berry, Alabama. This coal contrasted sharply with the very friable Lower Sunnyside coal mined at Kaiser Coal's Sunnyside Mine.

Roof and floor rocks tested ranged from a very hard sandy shale at Kaiser Coal's Sunnyside Mine to claystone at the Jim Walter Resources No. 3 Mine.

The procedure described under Part 3.0 (Measurement Plan) of the Experimental Program Definition was strictly adhered to during all of the data acquisition visits. A more detailed description of the test procedure follows.

Prior to entering the mine, a final check was made on the power supplies of all test equipment, and discussions were held with mine personnel to determine which cutting drum was most suited for instrumentation. The cutting drum selected was the one which ranged most throughout the mine strata.

Upon arriving at the longwall face, two fabricated accelerometer mounting plates were welded to the shearer. One of the mounting plates was attached to the ranging arm near the cutting drum, and the remaining plate was situated on top of the machine chassis. The metal enclosures housing the accelerometers were attached to the mounting plates with 2 3/4-inch sections of 5/8-inch diameter all thread and assorted fastening hardware.

The coaxial leads used to connect the accelerometers to the power supplies and the CID were protected by a 1/2-inch rubber jacket flexible conduit. Microdot connectors were used to connect the coaxial cable to the accelerometers and to the power supplies of the survey accelerometers. BNC connectors were used to connect the coaxial cable to the CID input and to the input cable of the TEAC-HR30E tape

TABLE 2. Summary of the Geology Encountered During Mine Testing

SHEARER	MINE	SEAM THICKNESS	ROOF MATERIAL	FLOOR MATERIAL	TEST DATE
Anderson Mavor 500	Jim Walter Resources No. 3 Mine Adger, Alabama	78"	Shale (hard)	Shale and clay (soft)	8/24/86
Eickhoff 150-2L	North River Energy Corporation Berry, Alabama	55"	Shale (hard)	Shale and Clay (soft)	9/15/86
Anderson Mavor 500	Jim Walter Resources No. 3 Mine Adger, Alabama	78"	Shale (hard)	Shale and Clay (soft)	9/28/86
Eickhoff 150-2L	North River Energy Corporation	55"	Shale (hard)	Shale and Clay (soft)	10/3/86
JOY ILS	Emway Resources Emerald No. 1 Mine	72"	Shale (hard)	Shale	11/17/86
Anderson Mavor 500	Jim Walter Resources No. 3 Mine Adger, Alabama	78"	Shale (hard)	Shale and Clay (soft)	11/23/86
Eickhoff 150-2L	North River Energy Corporation Berry, Alabama	55"	Shale (hard)	Shale and Clay (soft)	12/1/86
Misui Mike	Kaiser Coal Sunnyside Mine	78"	Laminated Sandy Shale (hard)	Laminated Sandy Shale (hard)	12/8/86

recorder. Since the TEAC-HR30E tape recorder is very lightweight (approximately 1.3 pounds), it was easily carried around the shoulder of the data collection team member by using the shoulder strap provided with the carrying case. Several J-hooks were tacked to the ranging arm in order to tie-wrap the flexible conduit against the arm.

There were two instances (Jim Walter Resources No. 3 Mine, Visit 3; Emway Resources Emerald No. 1 Mine, Visit 2) where the coaxial leads from triaxial accelerometer location 1 were severely damaged. Other than CID malfunction, this was the only other adversity encountered during testing.

The data collection team member responsible for voice annotating the data tapes was in charge of mounting the data collection system. The other member of the data collection team was in charge of taking hardness measurements and also samples of the coal and rock from along the longwall face.

A Schmidt Concrete Test Hammer (Type N) was used to measure the hardness of the coal and rock strata. When this device was applied on a highly fractured coal face, no reading was registered on the rebound number scale. The rebound number indicates the hardness of material tested. In these instances, the rebound values recorded were obtained on a large sample of coal taken from that face location. A crucial question arises as to which of these hardness values are detected by the CID. The premise of the data analysis is based on the assumption that the CID encounters a coal hardness in magnitude of that which was recorded from the large coal sample. The range of the coal/rock hardness values along the longwall face of Kaiser Coal's Sunnyside Mine was not adequately measured due to a malfunction of the test hammer during this visit. The test hammer was inoperable after taking just a few hardness measurements.

An average of ten impact readings were taken with the hammer on each stratum at every shield test location. Rebound values that did not deviate by more than five units from the means of the others were used in calculating the mean value of the rebound number at the test locations. A note was made as to the direction into which the impact testing was conducted.

Coal and rock samples were taken at each shield test location. The procedure described in Appendix D was used to determine the bulk density of each sample. The average of these bulk densities were entered as data input on the data reduction form for each mine visit.

Generally, the first vibration data recorded was when the cutting drums were powered and rotating in the air. Frequently, this was followed by the recording of the startup of the face conveyor. Consequently, additional background noise information on the shearer and conveyor were acquired.

The majority of data was collected during actual cutting operations. The data collection team member in charge of voice annotating the tape was stationed between the shearer operators at a known distance from the instrumented cutting drum. His responsibilities were to locate the instrumented drum with a shield number during the cutting operation and to note all pertinent shearer operating data. This included noting when the shearer stopped, started, or idled and also when the pan line stopped or started and its load condition.

The second data collection team member was in charge of observing and noting the location of the instrumented drum with respect to the coal/rock interface. As stated earlier, the most suited position for this member was found to be ahead of the cutting action where a more accurate account of depth of cut into rock could be recorded. The depth of cut was observed and noted as it was occurring rather than in an after-the-fact manner. When the cutting drum was lowered into the floor and the interface difficult to observe, the operator provided the depth-of-cut information. The accuracy of these observations are estimated to be within 2 to 4 inches.

During testing, the instrumented cutting drum was monitored during normal cutting operations which consisted of cutting as close to the interface as possible. This resulted in the cutting drum operating approximately 1 inch above and below the interface. At several points along the face, the operator was instructed to take a deeper cut (greater than 2 inches) into the rock stratum.

A minimum of three passes of data were collected during each visit except in one instance when the shearer broke down during testing and remained inoperable (North River Energy Corporation, visit 1). The data acquisition phase of this project resulted in the collection of 29 cassette tapes of data. Fifteen of these tapes were suitable for CID evaluation; the remaining tapes contain questionable values of the analog output due to CID malfunction. The raw vibration data collected from the survey accelerometers on all of the data tapes is suitable for future use.

Prior to the commencement of data acquisition visits, the CID's had not operated in a mine environment. The operation of the detector had been evaluated in a laboratory which can be considered to be ideal conditions when compared with the atmosphere of an operating longwall face. During the early stages of testing, the values recorded for the output of the CID's were questionable (i.e., 50 to 85 mV range).

An inquiry was made to determine the cause of these questionable values. The results of this investigation revealed that several CID electronic components had failed and that the charge on the NiCad power supplies had depleted rapidly.

The humid mine environment caused condensate to form inside the explosion-proof box housing the CID electronics. This condensate rendered various chips and regulators inoperative. The age of the detector (approximately nine years old at time of testing) may have been an integral part of this problem.

Extensive time run checks were conducted on the original and new NiCad power supplies. The conclusion arrived at from the results of this investigation was that recommended charging procedure (G.E. Operating Manual) did not adequately charge the power supplies for mine testing. The battery charger specified for use was not suitable for charging the NiCad power supplies. New chargers were purchased (Globe Union 2435OM) and a charging procedure was developed.

The procedure involved connecting the charger to the external lead of the CID marked "CHARGER." Charging required about 18 hours. The charge on each unit was checked just prior to entering the mine and directly after exiting the mine.

VI. DATA REDUCTION AND ANALYSIS

The recorded CID analog output data was played through a Hewlett Packard Model 3467A Logging Multimeter with a TEAC R-71 tape player. The RMS value of the CID output (Appendix A, Supplement to the Final Report) for all recorded data points (shield locations) was entered on a data reduction form. The velocities between the shields was calculated from the information contained on the data tapes. The coal and rock hardness values entered on the reduced data form are the average rebound values taken with the Schmidt Concrete Test Hammer between two hardness sample locations. The Rebound Number indicates the hardness of the material tested. A data reduction form was prepared for each shearer pass and then stored on a computer data file. A printout of these data files are shown in Appendix A of the Supplement to the Final Report. The following analysis was then derived from the information contained on the computer data files.

Figures 6 and 7 are example plots of the primary factors data (analog signal, depth of cut, hardness ratio, and velocity) collected for this project. The remaining plots are shown in Appendix B of the "Supplement to the Final Report." These plots correlate all the data according to the longwall face position at which it occurred. The operating characteristics of the mines that participated in this project are shown in Appendix B.

JIM WALTER RESOURCES NO. 3 MINE

Figures 6 and 7 are plots of the primary data collected for two cutting passes at the Jim Walter Resources No. 3 Mine located in Adger, Alabama. The level of analog signal that is most prevalent in these figures ranges from 0 to 3 volts and is found to be equally associated with both coal and rock cutting. Figure 7 shows that an analog signal range of from 4.5 to 5.5 volts to be strongly associated with cutting 12 inches of rock.

The hardness ratios found at the Jim Walter Resources No. 3 Mine ranged from 0.2 to 0.75. All of the CID analog signal outputs had their greatest recurrence when the hardness ratio was equal to or greater than 0.5 but less than 0.7. (Figures 6 and 7).

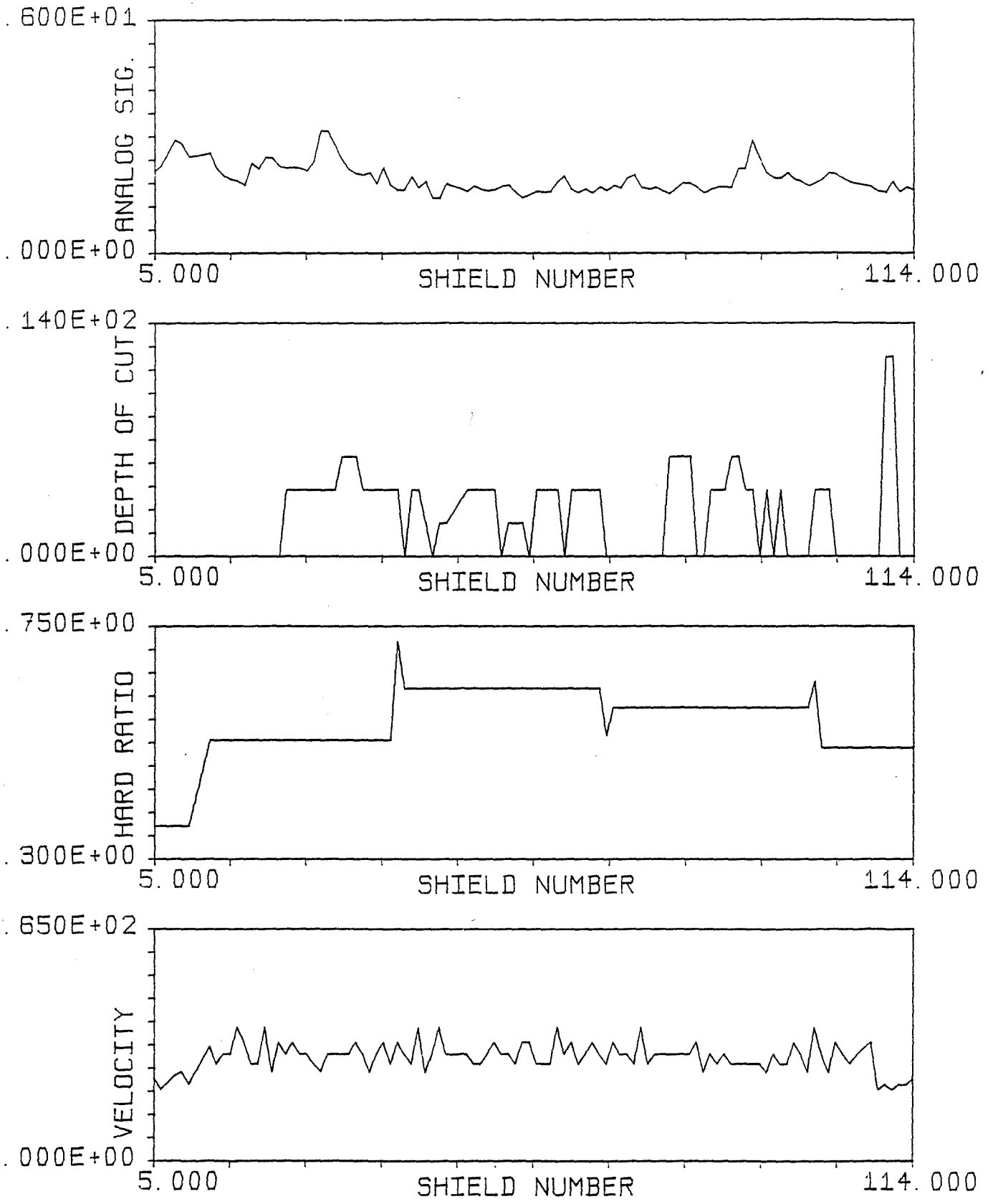

J. W. #3 VIS. #3 PASS#1 H TO T CUTTING
 DATASET 20

FIGURE 6. Primary Data Plot for the Jim Walter Resources No. 3 Mine

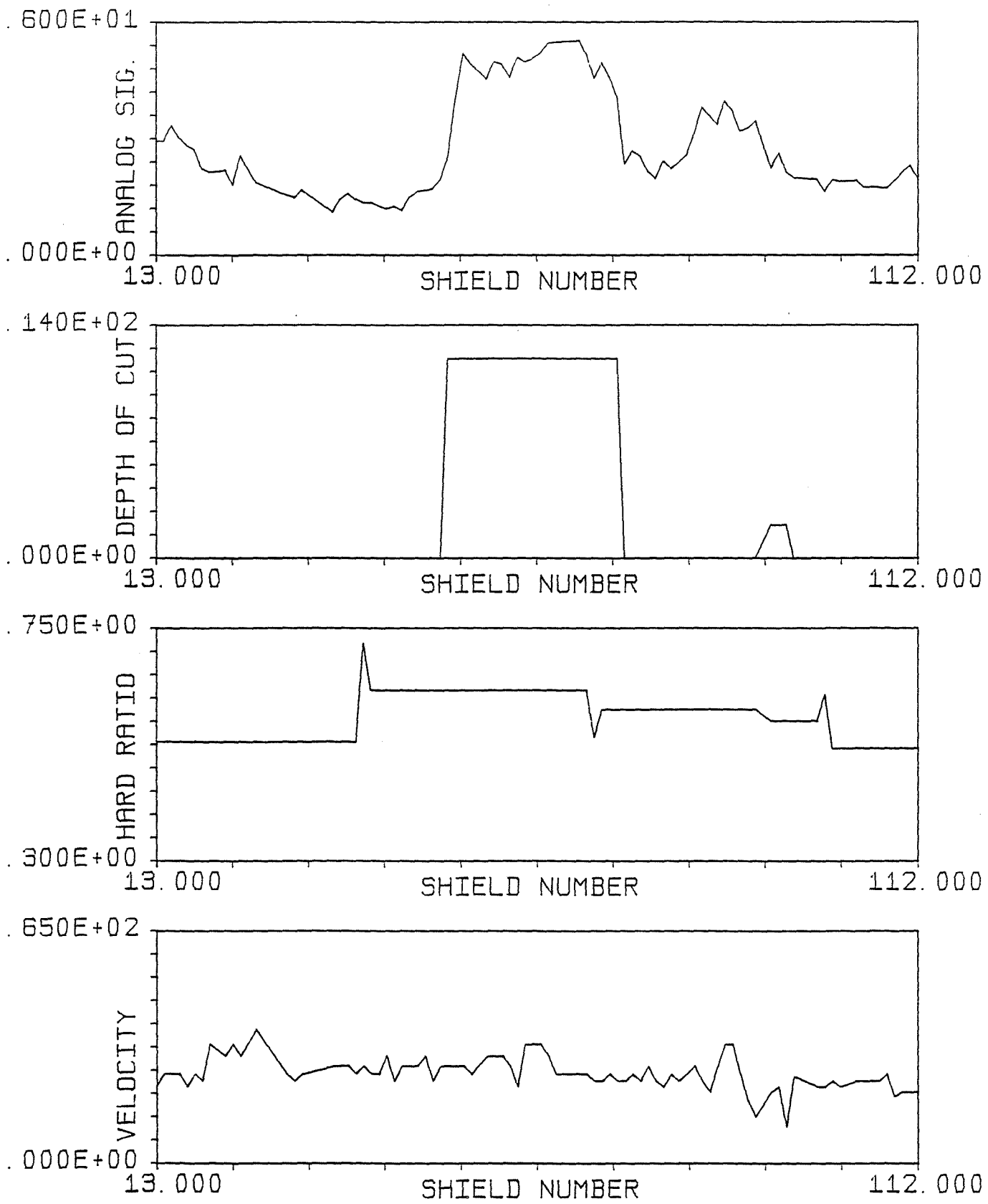

J. W. #3 VIS. #3 PASS#2 T TO H CLEANUP
 DATASET 21

FIGURE 7. Primary Data Plot for the Jim Walter Resources No. 3 Mine

An operating velocity equal to and greater than 20 fpm but less than 33.3 fpm was most common at this property (Figures 6 and 7). For a velocity rank of greater than 33.3 fpm, an analog signal level equal to or greater than 3 volts but less than 5 volts had a greater frequency of occurrence (Table 3).

Shown in Table 3 is the variance of each of the levels of analog signal data for each of the levels of the primary factors involved in this experiment. The percentages discussed in the following text are derived from this table.

Assume that an analog signal value of less than 1 volt (A_1) would be obtained for coal cutting (Level B_1). The percentage of correct cutting signals would be found to be approximately 32-percent correct for coal cutting and 74-percent correct for rock cutting (Figure 8). When assuming that an analog signal level of less than 3 volts (A_1 , A_2) is associated with coal cutting (B_1), then approximately 93 percent of the coal cutting and 32 percent of the rock cutting signals would be correct (Figure 9). For an assumption that an analog signal level of less than 5 volts (A_1 , A_2 , A_3) is associated with coal cutting (B_1), then the percentage of correct cutting signals is found to be correct approximately 100 percent of the time for coal cutting and 4 percent of the time for rock cutting (Figure 10).

The data in Tables 3 and 4 and the bar charts shown in Figures 8 through 11 conclude that the CID was not effective in determining the coal/rock interface at this minesite. There was no level of analog signal that distinguished between coal and rock cutting.

TABLE 3. Percentage of Occurrence of Analog Signal for Each Primary Factor,
Jim Walter Resources No. 3 Mine

JIM WALTER RESOURCES No.3 MINE							
TOTAL NUMBER OF DATA POINTS=687							
PERCENTAGE OF OCCURRENCE							
ANALOG SIGNAL VS. DEPTH OF CUT							
ANALOG SIGNAL=A							
ANALOG SIGNAL LEVEL							
A1: 0<X<1.0							
A2: 1.0<X<3.0							
A3: 3.0<X<5.0	DEPTH OF CUT	A1	A2	A3	A4	TOTAL	
A4: 5.0<X<8.0	B1	156 (22.71)	293 (42.65)	33 (4.80)	0	482 (70.16)	
	B2	4 (0.58)	4 (0.58)	2 (0.29)	0	10 (1.45)	
	B3	28 (4.28)	61 (8.88)	28 (4.08)	0	117 (17.04)	
DEPTH OF CUT=B	B4	20 (2.91)	22 (3.20)	28 (4.08)	8 (1.16)	78 (11.35)	
B1: 0<X<0.1	TOTAL	208(30.28)	380 (55.31)	91 (13.25)	8 (1.16)	687 (100)	
B2: 0.1<X<2.0							
B3: 2.0<X<6.0							
B4: 6.0<X<60							
ANALOG SIGNAL VS. HARDNESS RATIO							
HARDNESS RATIO=C							
ANALOG SIGNAL LEVEL							
C1: 0.2<X<0.5	HARDNESS RATIO	A1	A2	A3	A4	TOTAL	
C2 0.5<X<0.7	C1	13 (1.89)	156 (22.71)	0	0	169 (24.60)	
C3: 0.7<X<0.9	C2	194 (28.24)	222 (32.31)	90 (13.10)	8 (1.16)	514 (74.81)	
C4: 0.9<X<1.2	C3	0	2 (0.29)	1 (0.15)	0	3 (0.44)	
	C4	1 (0.15)	0	0	0	1 (0.15)	
VELOCITY=D	TOTAL	208 (30.28)	380 (55.31)	91 (13.25)	8 (1.16)	687 (100)	
D1: 0<X<10							
D2: 10<X<20							
D3: 20<X<33.3							
D4:33.3<X<70							
ANALOG SIGNAL VS. VELOCITY							
ANALOG SIGNAL LEVEL							
	VELOCITY	A1	A2	A3	A4	TOTAL	
	D1	1 (0.15)	0	0	0	1 (0.15)	
	D2	24 (3.49)	40 (5.28)	2 (0.29)	0	66 (9.60)	
	D3	143 (20.82)	247 (35.95)	28 (4.08)	6 (0.87)	424 (61.72)	
	D4	40 (5.82)	93 (13.54)	61 (8.88)	2 (0.29)	196 (28.53)	
	TOTAL	208 (30.28)	380 (55.31)	91 (13.25)	8 (0.87)	687 (100)	

% OF CUTTING SIGNALS JIM WALTERS NO.3 (A.S.<1)

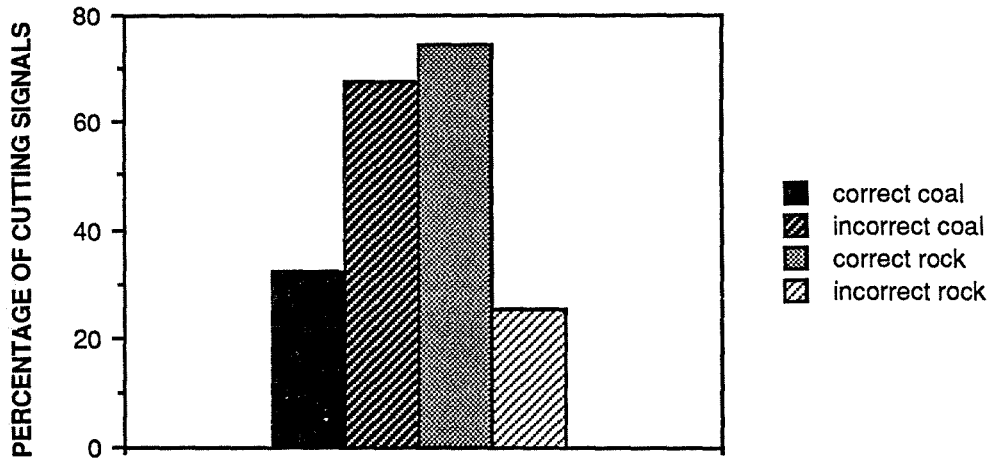

FIGURE 8. Percentage of Correct and Incorrect Coal and Rock Cutting Signals (Analog Signal <1), Jim Walter Resources No. 3 Mine

% OF CUTTING SIGNALS JIM WALTERS NO. 3 (A.S.<3)

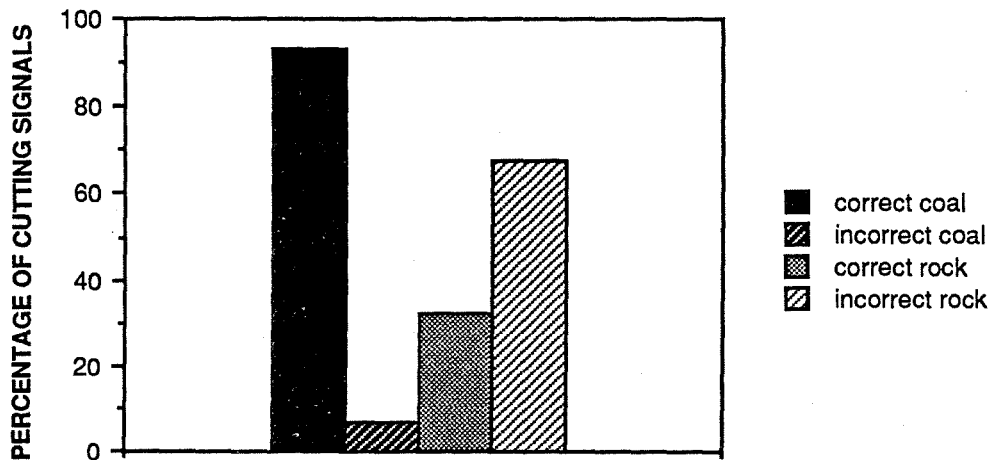

FIGURE 9. Percentage of Correct and Incorrect Coal and Rock Cutting Signals (Analog Signal <3), Jim Walter Resources No. 3 Mine

% OF CUTTING SIGNALS JIM WALTERS NO. 3 (A.S.<5)

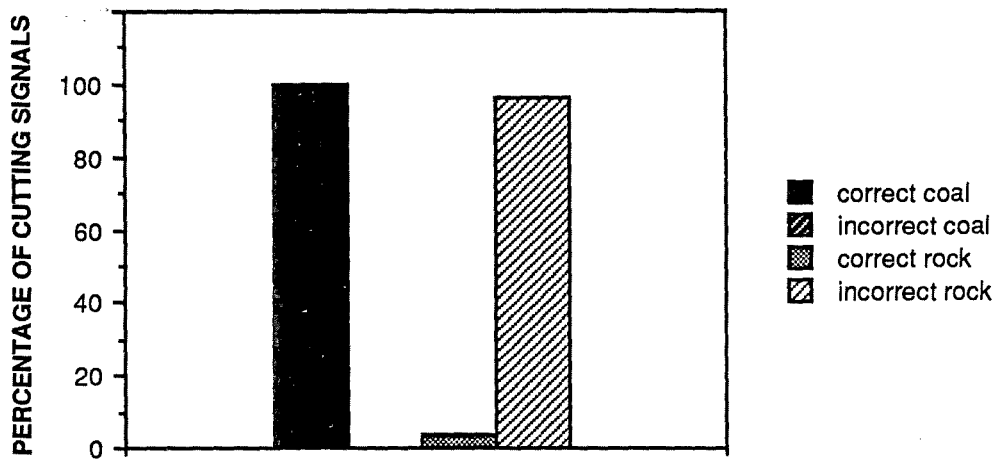

FIGURE 10. Percentage of Correct and Incorrect Coal and Rock Cutting Signals (Analog Signal <5), Jim Walter Resources No. 3 Mine

% OF CUTTING SIGNALS JIM WALTERS NO. 3 (A.S.<8)

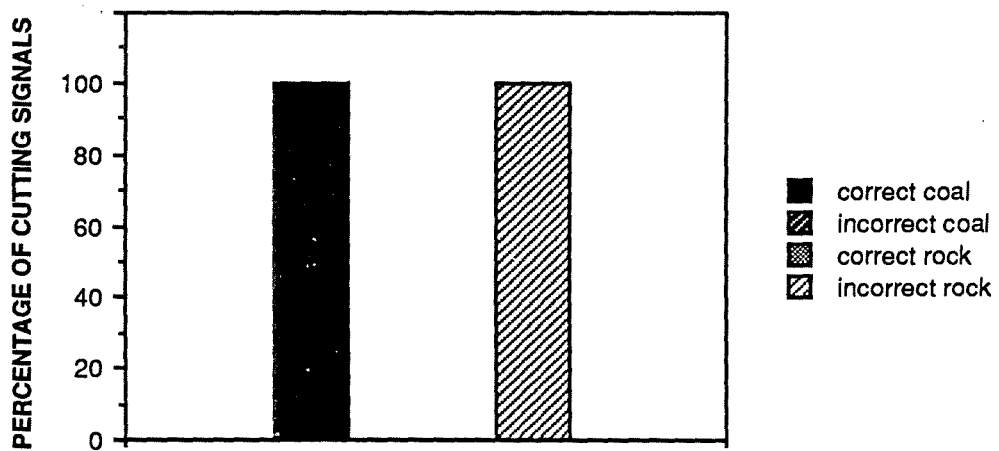

FIGURE 11. Percentage of Correct and Incorrect Coal and Rock Cutting Signals (Analog Signal <8), Jim Walter Resources No. 3 Mine

**TABLE 4. Percentage of Occurrence of Each Level of Analog Signal for each Level of Primary Factor,
Jim Walter Resources No. 3 Mine**

JIM WALTER RESOURCES NO. 3 MINE							
TOTAL NUMBER OF DATA POINTS =687							
ANALOG SIGNAL =A	ANALOG	SIGNAL	LEVEL	NUMBER	CONE		
A1: 0<X<1.0							
A2: 1.0<X<3.0	FACTORS	C1	C2	C3	C4	TOTAL	
A3: 3.0<X<5.0	B1	13 (6.25%)	142 (68.27%)	0	1 (0.48%)	156	(75.00%)
A4: 5.0<X<8.0	B2	0	4 (1.92%)	0	0	4	(1.92%)
	B3	0	28 (13.46%)	0	0	28	(13.46%)
DEPTH OF CUT =B	B4	0	20 (9.62%)	0	0	20	(9.62%)
B1: 0<X<0.1	TOTAL	13 (6.25%)	194 (93.27%)	0	1 (0.48%)	208	(100%)
B2: 0.1<X<2.0							
B3: 2.0<X<6.0							
B4: 6.0<X<60							
HARDNESS RATIO =C	FACTORS	D1	D2	D3	D4	TOTAL	
C1: 0.2<X<0.5	B1	1 (0.48%)	17 (8.17%)	126(60.58%)	12 (5.77%)	156	(75.00%)
C2: 0.5<X<0.7	B2	0	2 (0.96%)	2(0.96%)	0	4	(1.92%)
C3: 0.7<X<0.9	B3	0	5 (2.40%)	10 (4.81%)	13 (6.25%)	28	(13.46%)
C4: 0.9<X<1.2	B4	0	0	5(2.40%)	15 (7.22%)	20	(9.62%)
	TOTAL	1 (0.48%)	24 (11.53%)	143(68.75%)	40 (19.24%)	208	(100%)
VELOCITY =D							
D1: 0<X<10							
D2: 10<X<20							
D3: 20<X<33.3							
D4:33.3<X<70							
	ANALOG	SIGNAL	LEVEL	NUMBER	TWO		
	FACTORS	C1	C2	C3	C4	TOTALS	
	B1	151 (39.74%)	141 (37.10%)	1 (0.26%)	0	293	(77.10%)
	B2	0	4 (1.05%)	0	0	4	(1.05%)
	B3	0	60 (15.80%)	1 (0.26%)	0	61	(16.06%)
	B4	5 (1.32%)	17 (4.47%)	0	0	22	(5.79%)
	TOTAL	156 (41.06%)	222 (58.42%)	2 (0.52%)	0	380	(100%)
	FACTORS	D1	D2	D3	D4	TOTALS	
	B1	0	38 (10.00%)	190 (50.00%)	65 (17.10%)	293	(77.10%)
	B2	0	0	4 (1.05%)	0	4	(1.05%)
	B3	0	2 (0.53%)	40 (10.53%)	19 (5.00%)	61	(16.06%)
	B4	0	0	13 (3.42%)	9 (2.37%)	22	(5.79%)
	TOTALS	0	40 (10.53%)	247 (65.00%)	93 (24.47%)	380	(100%)

T-7

TABLE 4. Percentage of Occurrence of Each Level of Analog Signal for each Level of Primary Factor, Jim Walter Resources No. 3 Mine (Concluded)

JIM WALTER RESOURCES NO. 3 MINE							
TOTAL NUMBER OF DATA POINTS =687							
ANALOG SIGNAL =A							
A1: 0<X<1.0	ANALOG	SIGNAL	LEVEL	NUMBER	THREE		
A2: 1.0<X<3.0	FACTORS	C1	C2	C3	C4	TOTALS	
A3: 3.0<X<5.0	B1	0	32 (35.16%)	1 (1.10%)	0	0	33 (36.26%)
A4: 5.0<X<8.0	B2	0	2 (2.20%)	0	0	0	2 (2.20%)
	B3	0	28 (30.77%)	0	0	0	28 (30.77%)
	B4	0	28 (30.77%)	0	0	0	28 (30.77%)
DEPTH OF CUT =B	TOTALS	0	90 (98.90%)	1 (1.10%)	0	0	91 (100%)
B1: 0<X<0.1							
B2: 0.1<X<2.0							
B3: 2.0<X<6.0							
B4: 6.0<X<60							
HARDNESS RATIO =C							
C1: 0.2<X<0.5	FACTORS	D1	D2	D3	D4	TOTALS	
C2: 0.5<X<0.7	B1	0	2 (2.20%)	14 (15.30%)	17 (18.68%)	0	33 (36.26%)
C3: 0.7<X<0.9	B2	0	0	2 (2.20%)	0	0	2 (2.20%)
C4: 0.9<X<1.2	B3	0	0	2 (2.20%)	26 (28.57%)	0	28 (30.77%)
	B4	0	0	10 (10.99%)	18 (19.78%)	0	28 (30.77%)
	TOTALS	0	2 (2.20%)	28 (30.77%)	61 (67.03%)	0	91 (100%)
VELOCITY =D							
D1: 0<X<10	ANALOG	SIGNAL	LEVEL	NUMBER	FOUR		
D2: 10<X<20	FACTORS	C1	C2	C3	C4	TOTALS	
D3: 20<X<33.3	B1	0	0	0	0	0	0
D4:33.3<X<70	B2	0	0	0	0	0	0
	B3	0	0	0	0	0	0
	B4	0	8 (100%)	0	0	0	8 (100%)
	TOTALS	0	8 (100%)	0	0	0	8 (100%)
VELOCITY =D							
D1: 0<X<10	FACTORS	D1	D2	D3	D4	TOTALS	
D2: 10<X<20	B1	0	0	0	0	0	0
D3: 20<X<33.3	B2	0	0	0	0	0	0
D4:33.3<X<70	B3	0	0	0	0	0	0
	B4	0	0	6 (75.00%)	2 (25.00%)	0	8 (100%)
	TOTALS	0	0	6 (75.00%)	2 (25.00%)	0	8 (100%)

EMWAY RESOURCES, EMERALD NO. 1 MINE

Figures 12 and 13 are plots of the primary data collected for two cutting passes at the Emway Resources Emerald No. 1 Mine located in Waynesburg, Pennsylvania. The range of analog signal output recorded at this minesite was from 0 to 5 volts. A signal of greater than 0 volts but less than 1 volt was output most frequently and was associated equally with coal and rock cutting (Figures 12 and 13).

The hardness ratio measured at this minesite ranged from 0.5 to less than 1.2. The predominant level of hardness ratio encountered ranged from a value greater than or equal to 0.7 but less than 0.9 (Figures 12 and 13). A hardness ratio interval of a value equal to or greater than 0.5 but less than 0.7 was found to have a high frequency of occurrence for an analog signal interval of from 0 volts to 3 volts (Table 5).

The principal operating velocity identified for this minesite was in the range of 20 fpm to 33.3 fpm (Figures 12 and 13). It appears that a velocity interval of a value greater than or equal to 10 fpm but less than 20 fpm had the greatest influence on the analog signal that ranged from a value greater than or equal to 3 volts but less than 5 volts (Table 5).

The variance of each of the levels of analog signal for each of the levels of the primary factors is shown in Table 5. The percentages discussed in the following text are derived from this table.

The CID is found to be correct approximately 87 percent of the time for coal cutting and 35 percent of the time for rock cutting based on the assumption that an analog signal level of less than 1 volt (A_1) is associated with coal cutting (Figure 14). Based on the assumption that an analog signal level of less than 3 volts (A_1, A_2) is associated with coal cutting, it is determined that the CID is approximately 89-percent correct for coal cutting (B_1) and 17-percent correct in determining when rock (B_2, B_3, B_4) was being cut (Figure 15). An assumption that an analog signal level of less than 5 volts (A_1, A_2, A_3) be associated with coal cutting reveals that 100 percent of the time the CID output the correct signal for coal cutting (B_1), and the CID was incorrect 100 percent of the time in determining when rock (B_2, B_3, B_4) was being cut (Figure 16).

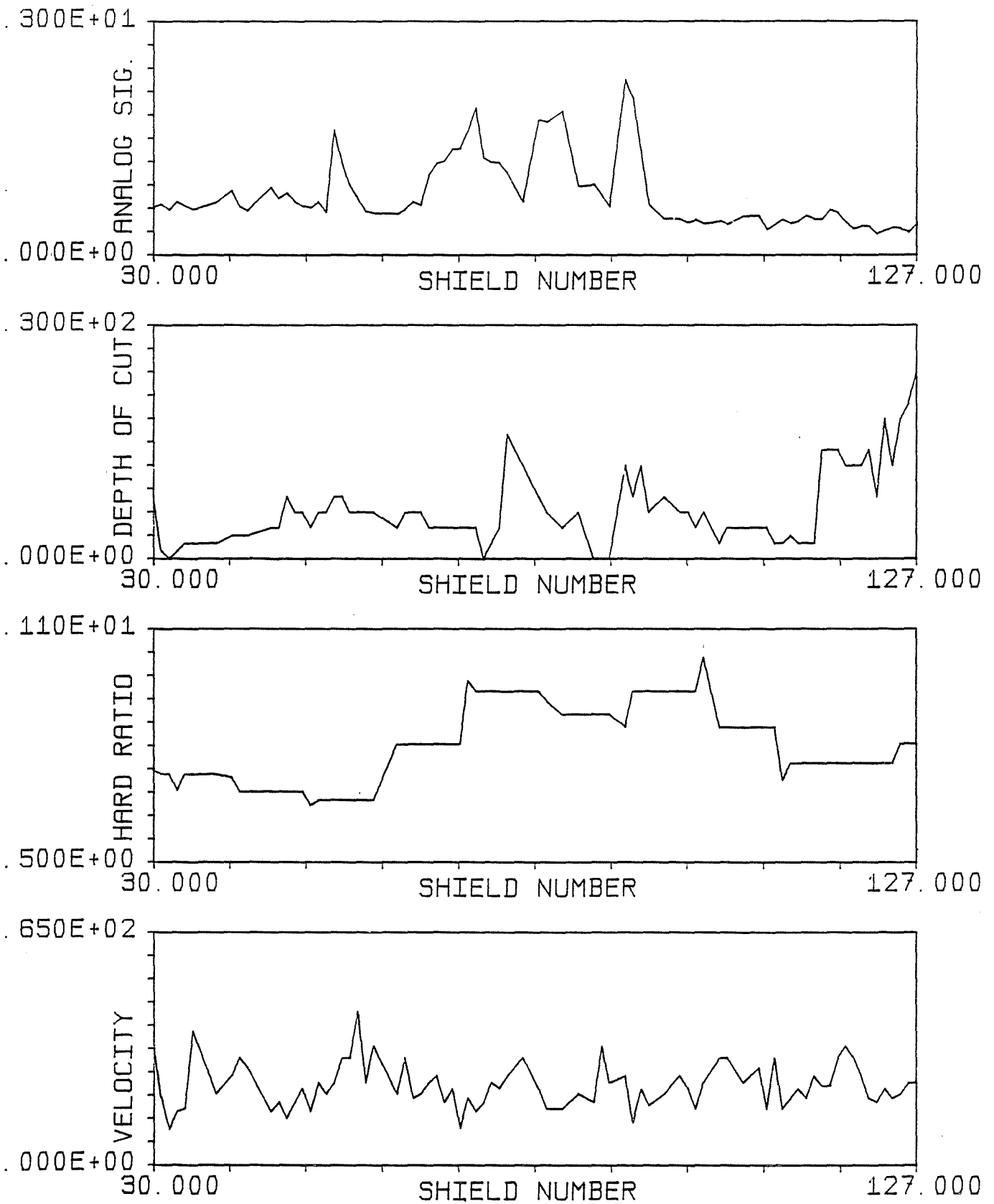

EMWAY RESOURCES VIS. #2 PASS#1 H TO T CUTTING
DATASET 27

FIGURE 12. Primary Data Plot for the Emway Resources, Emerald No. 1 Mine

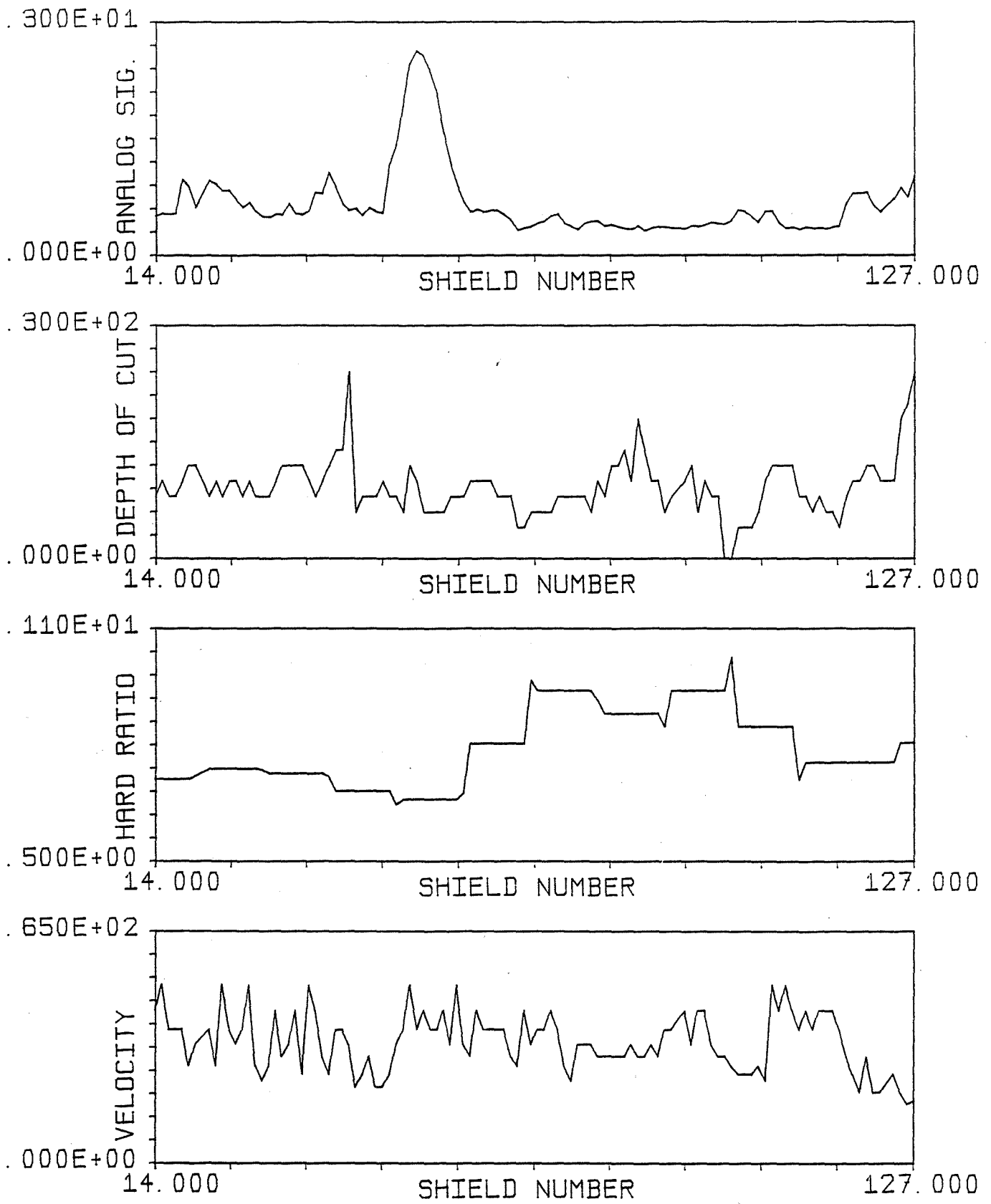

EMWAY RESOURCES VIS. #2 PASS#5 H TO T CUTTING
 DATASET 31

FIGURE 13. Primary Data Plot for the Emway Resources, Emerald No. 1 Mine

TABLE 5. Percentage of Occurrence of Analog Signal for Each Primary Factor,
Emway Resources, Emerald No. 1 Mine

EMWAY RESOURCES, EMERALD No.1 MINE							
TOTAL NUMBER OF DATA POINTS=790							
			PERCENTAGE	CF	OCCURRENCE		
	ANALOG	SIGNAL	VS.	ANALOG	SIGNAL	DEPTH	CF
						CUT	
ANALOG SIGNAL=A							
A1: 0<X<1.0				ANALOG	SIGNAL	LEVEL	
A2: 1.0<X<3.0	DEPTH OF CUT	A1	A2	A3	A4	TOTAL	
A3: 3.0<X<5.0	B1	238 (30.13)	4 (0.51)	30 (3.80)		0	272 (34.44)
A4: 5.0<X<8.0	B2	10 (1.27)	2 (0.24)	1 (0.12)		0	13 (1.63)
	B3	138 (17.47)	24 (3.04)	4 (0.51)		0	166 (21.02)
	B4	188 (23.80)	70 (8.86)	81 (10.25)		0	339 (42.91)
	TOTAL	574 (72.67)	100 (12.65)	116 (14.68)		0	790 (100)
DEPTH OF CUT=B							
B1: 0<X<0.1							
B2: 0.1<X<2.0							
B3: 2.0<X<6.0							
B4: 6.0<X<60	ANALOG	SIGNAL	VS.	HARDNESS	RATIO		
HARDNESS RATIO=C							
C1: 0.2<X<0.5	HARDNESS RATIO	A1	A2	A3	A4	TOTAL	
C2: 0.5<X<0.7	C1	0	0	0		0	0
C3: 0.7<X<0.9	C2	200 (25.33)	40 (5.05)	1 (0.12)		0	241 (30.50)
C4: 0.9<X<1.2	C3	330 (41.77)	47 (5.95)	115 (14.56)		0	492 (62.28)
	C4	44 (5.57)	13 (1.65)	0		0	57 (7.22)
	TOTAL	574 (72.67)	100 (12.65)	116 (14.68)		0	790 (100)
VELOCITY=D							
D1: 0<X<10							
D2: 10<X<20							
D3: 20<X<33.3	ANALOG	SIGNAL	VS.	VELOCITY			
D4: 33.3<X<70				ANALOG	SIGNAL	LEVEL	
	VELOCITY	A1	A2	A3	A4	TOTAL	
	D1	3 (0.38)	0	4 (0.52)		0	7 (0.90)
	D2	83 (10.51)	17 (2.15)	60 (7.59)		0	160 (20.25)
	D3	361 (45.70)	52 (6.58)	50 (6.32)		0	463 (58.60)
	D4	127 (16.08)	31 (3.92)	2 (0.25)		0	160 (20.25)
	TOTAL	574 (72.67)	100 (12.65)	116 (14.68)		0	790 (100)

% OF CUTTING SIGNALS EMWAY RESOURCES (A.S.<1)

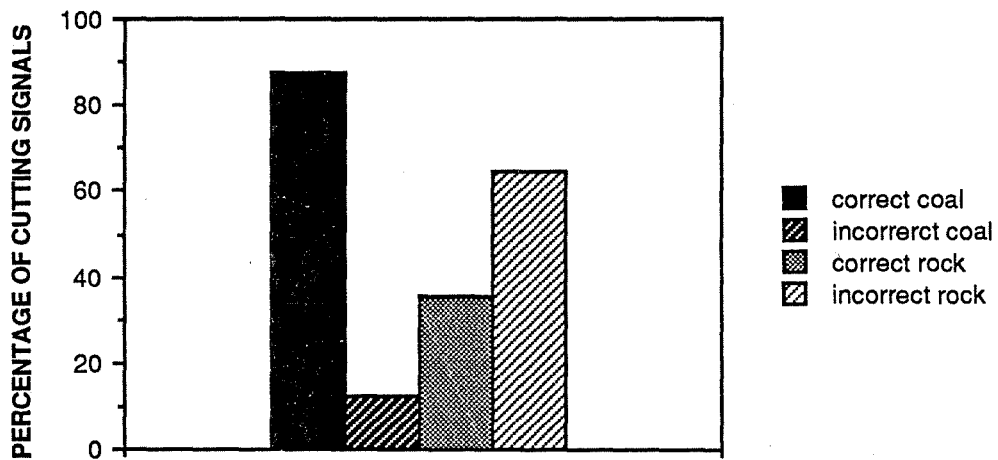

FIGURE 14. Percentage of Correct and Incorrect Coal and Rock Cutting Signals (Analog Signal <1), Emway Resources

% OF CUTTING SIGNALS EMWAY RESOURCES (A.S.<3)

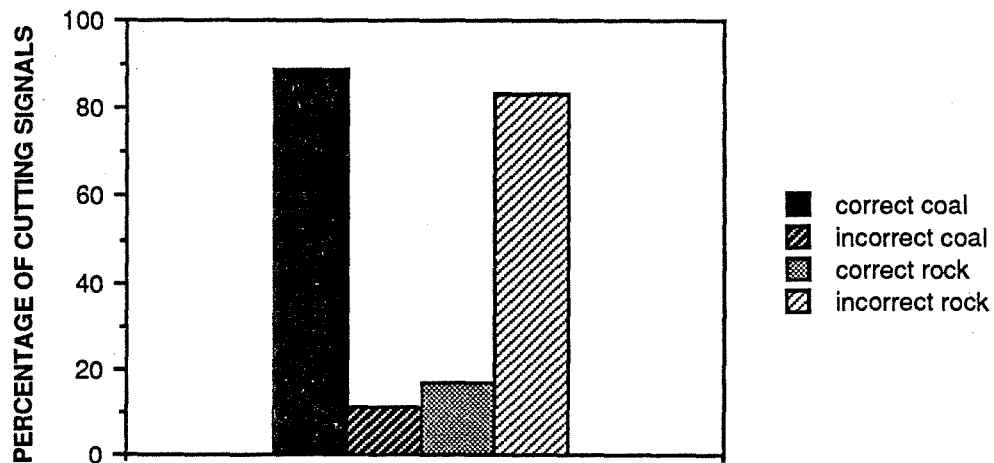

FIGURE 15. Percentage of Correct and Incorrect Coal and Rock Cutting Signals (Analog Signal <3), Emway Resources

% OF CUTTING SIGNALS EMWAY RESOURCES (A.S.<5)

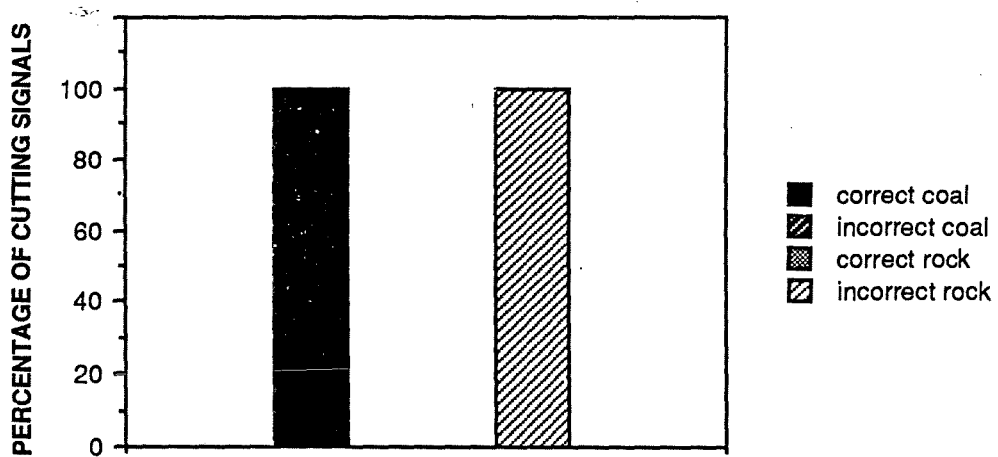

FIGURE 16. Percentage of Correct and Incorrect Coal and Rock Cutting Signals (Analog Signal <5), Emway Resources

The data in Tables 5 and 6 and the bar charts shown in Figures 14 through 16 infer that the CID was not effective in detecting the coal and rock interface. The predominant level of analog signal output ($0 \leq X < 1$) was found to be associated with both coal and rock cutting. In most instances, there was not a great difference between the coal and rock hardness values which is shown by the predominant hardness ratio. This may have had an effect on the analog output. The percentage of correct cutting signals reveals that the CID was ineffective in determining when the shearer drum had crossed the coal/rock interface.

TABLE 6. Percentage of Occurrence of Each Level of Analog Signal for Each Level of Primary Factor, Emway Resources, Emerald No. 1 Mine

	A	B	C	D	E	F	G	H
1	EMWAY RESOURCES EMERALD NO.1 MINE							
2	TOTAL NUMBER OF DATA POINTS = 790							
3								
4								
5	ANALOG SIGNAL= A		ANALOG	SIGNAL	LEVEL	NUMBER	ONE	
6	A1: 0<X<1.0							
7	A2: 1.0<X<3.0		FACTORS	C1	C2	C3	C4	TOTALS
8	A3: 3.0<X<5.0		B1	0	132 (23.00%)	103 (17.95%)	3 (0.52%)	238 (41.47%)
9	A4: 5.0<X<8.0		B2	0	1 (0.17%)	9 (1.57%)	0	10 (1.47%)
10			B3	0	36 (6.27%)	101 (17.60%)	1 (0.17%)	138 (24.04%)
11	DEPTH OF CUT= B		B4	0	31 (5.40%)	117 (20.38%)	40 (6.97%)	188 (32.75%)
12	B1: 0<X<0.1		TOTALS	0	200 (34.84%)	330 (57.50%)	44 (7.66%)	574 (100%)
13	B2: 0.1<X<2.0							
14	B3: 2.0<X<6.0							
15	B4: 6.0<X<60							
16			FACTORS	D1	D2	D3	D4	TOTALS
17	HARDNESS RATIO= C		B1	2 (0.35%)	34 (5.93%)	170 (29.62%)	32 (5.57%)	238 (41.47%)
18	C1: 0.2<X<0.5		B2	0	8 (1.39%)	2 (0.35%)	0	10 (1.74%)
19	C2: 0.5<X<0.7		B3	0	23 (4.01%)	105 (18.29%)	10 (1.74%)	138 (24.04%)
20	C3: 0.7<X<0.9		B4	1 (0.17%)	18 (3.14%)	84 (14.63%)	85 (14.81%)	188 (32.75%)
21	C4: 0.9<X<1.2		TOTALS	3 (0.52%)	83 (14.47%)	361 (62.89%)	127 (22.12%)	574 (100%)
22								
23	VELOCITY= D							
24	D1: 0<X<10							
25	D2: 10<X<20							
26	D3: 20<X<33.3		ANALOG	SIGNAL	LEVEL	NUMBER	TWO	
27	D4: 33.3<X<70							
28			FACTORS	C1	C2	C3	C4	TOTALS
29			B1	0	1 (1.00%)	2 (2.00%)	1 (1.00%)	4 (4.00%)
30			B2	0	0	2 (2.00%)	0	2 (2.00%)
31			B3	0	9 (9.00%)	11 (11.00%)	4 (4.00%)	24 (24.00%)
32			B4	0	30 (30.00%)	32 (32.00%)	8 (8.00%)	70 (70.00%)
33			TOTALS	0	40 (40.00%)	47 (47.00%)	13 (13.00%)	100 (100%)
34								
35								
36								
37			FACTORS	D1	D2	D3	D4	TOTALS
38			B1	0	1 (1.00%)	1 (1.00%)	2 (2.00%)	4 (4.00%)
39			B2	0	1 (1.00%)	1 (1.00%)	0	2 (2.00%)
40			B3	0	5 (5.00%)	17 (17.00%)	2 (2.00%)	24 (24.00%)
41			B4	0	10 (10.00%)	33 (33.00%)	27 (27.00%)	70 (70.00%)
42			TOTALS	0	17 (17.00%)	52 (52.00%)	31 (31.00%)	100 (100%)
43								
44								

TABLE 6. Percentage of Occurrence of Each Level of Analog Signal for Each Level of Primary Factor, Emway Resources, Emerald No. 1 Mine (Concluded)

	A	B	C	D	E	F	G	H
4 5	EMWAY RESOURCES EMERALD NO.1 MINE							
4 6	TOTAL NUMBER OF DATA POINTS = 790							
4 7								
4 8								
4 9	ANALOG SIGNAL= A		ANALOG	SIGNAL	LEVEL	NUMBER	THREE	
5 0	A1: 0<X<1.0							
5 1	A2: 1.0<X<3.0		FACTORS	C1	C2	C3	C4	TOTALS
5 2	A3: 3.0<X<5.0		B1	0	1 (0.86%)	29 (25.00%)	0	30 (25.86%)
5 3	A4: 5.0<X<8.0		B2	0	0	1 (0.86%)	0	1 (0.86%)
5 4			B3	0	0	4 (3.45%)	0	4 (3.45%)
5 5	DEPTH OF CUT= B		B4	0	0	81 (69.83%)	0	81 (69.83%)
5 6	B1: 0<X<0.1		TOTALS	0	1 (0.86%)	115 (99.14%)	0	116 (100%)
5 7	B2: 0.1<X<2.0							
5 8	B3: 2.0<X<6.0							
5 9	B4: 6.0<X<60							
6 0			FACTORS	D1	D2	D3	D4	TOTALS
6 1	HARDNESS RATIO= C		B1	0	15 (12.93%)	13 (11.21%)	2 (1.72%)	30 (25.86%)
6 2	C1: 0.2<X<0.5		B2	0	0	1 (0.86%)	0	1 (0.86%)
6 3	C2: 0.5<X<0.7		B3	0	1 (0.86%)	3 (2.59%)	0	4 (3.45%)
6 4	C3: 0.7<X<0.9		B4	4 (3.45%)	44 (37.93%)	33 (28.45%)	0	81 (69.83%)
6 5	C4: 0.9<X<1.2		TOTALS	4 (3.45%)	60 (51.72%)	50 (43.11%)	2 (1.72%)	116 (100%)
6 6								
6 7	VELOCITY= D							
6 8	D1: 0<X<10							
6 9	D2: 10<X<20							
7 0	D3: 20<X<33.3		ANALOG	SIGNAL	NUMBER	FOUR		
7 1	D4: 33.3<X<70							
7 2			FACTORS	C1	C2	C3	C4	TOTALS
7 3			B1	0	0	0	0	0
7 4			B2	0	0	0	0	0
7 5			B3	0	0	0	0	0
7 6			B4	0	0	0	0	0
7 7			TOTALS	0	0	0	0	0
7 8								
7 9								
8 0								
8 1			FACTORS	D1	D2	D3	D4	TOTALS
8 2			B1	0	0	0	0	0
8 3			B2	0	0	0	0	0
8 4			B3	0	0	0	0	0
8 5			B4	0	0	0	0	0
8 6			TOTALS	0	0	0	0	0

KAISER COAL'S SUNNYSIDE MINE

Two examples of the plots of the primary data collected at Kaiser Coal's Sunnyside Mine are shown in Figures 17 and 18. The value of the CID analog signal output voltage recorded during this visit ranged from values greater than 0 volts to less than 5 volts. The prevalent range of analog signal output recorded at this minesite ranged from 0 volts to a value less than 1 volt. This level of analog output was associated with cutting both coal and rock (Figures 17 and 18).

The level of hardness ratio measured was from 0.7 to a value less than 0.9 (C_3). The horizontal line shown for the hardness ratio profiles is attributed to the malfunction of the Schmidt Concrete Test Hammer during this visit. Hardness values had been taken at only a few test locations when the Schmidt test hammer became inoperable.

A velocity of between 20 fpm to 33.3 fpm was found to be the principal operating velocity at this minesite. The analog signal output that was recurrent with this level of velocity was from 0 volts to a value less than 5 volts (A_1, A_2, A_3) (Figures 17 and 18 and Table 7). A analog output of from 0 volts to less than 1 volt (A_1) also had a high frequency of occurrence with a velocity of from 10 fpm to a value less than 20 fpm (D_2) (Table 7).

The variance of each of the levels of analog signal for each of the levels of the primary factors is shown in Table 7. The percentage discussed in the following text are derived from this table.

Assuming that an analog signal voltage of less than 1 volt (A_1) is associated with coal cutting presents the CID as being approximately 97-percent correct in determining when coal (B_1) was being cut and 17-percent correct in determining when rock (B_2, B_3, B_4) was being cut (Figure 19). The assumption that an analog voltage of less than 3 volts (A_1, A_2) is associated with coal cutting (B_1) reveals that the CID was 99-percent correct in determining when coal was being cut and 2-percent correct in determining when rock (B_2, B_3, B_4) was being cut (Figure 20). An assumption that an analog signal level of less than 5 volts (A_1, A_2, A_3) is associated with cutting coal reveals that the CID was 100-percent correct in determining when coal was being cut and 0-percent correct in determining when rock was being cut (Figure 21).

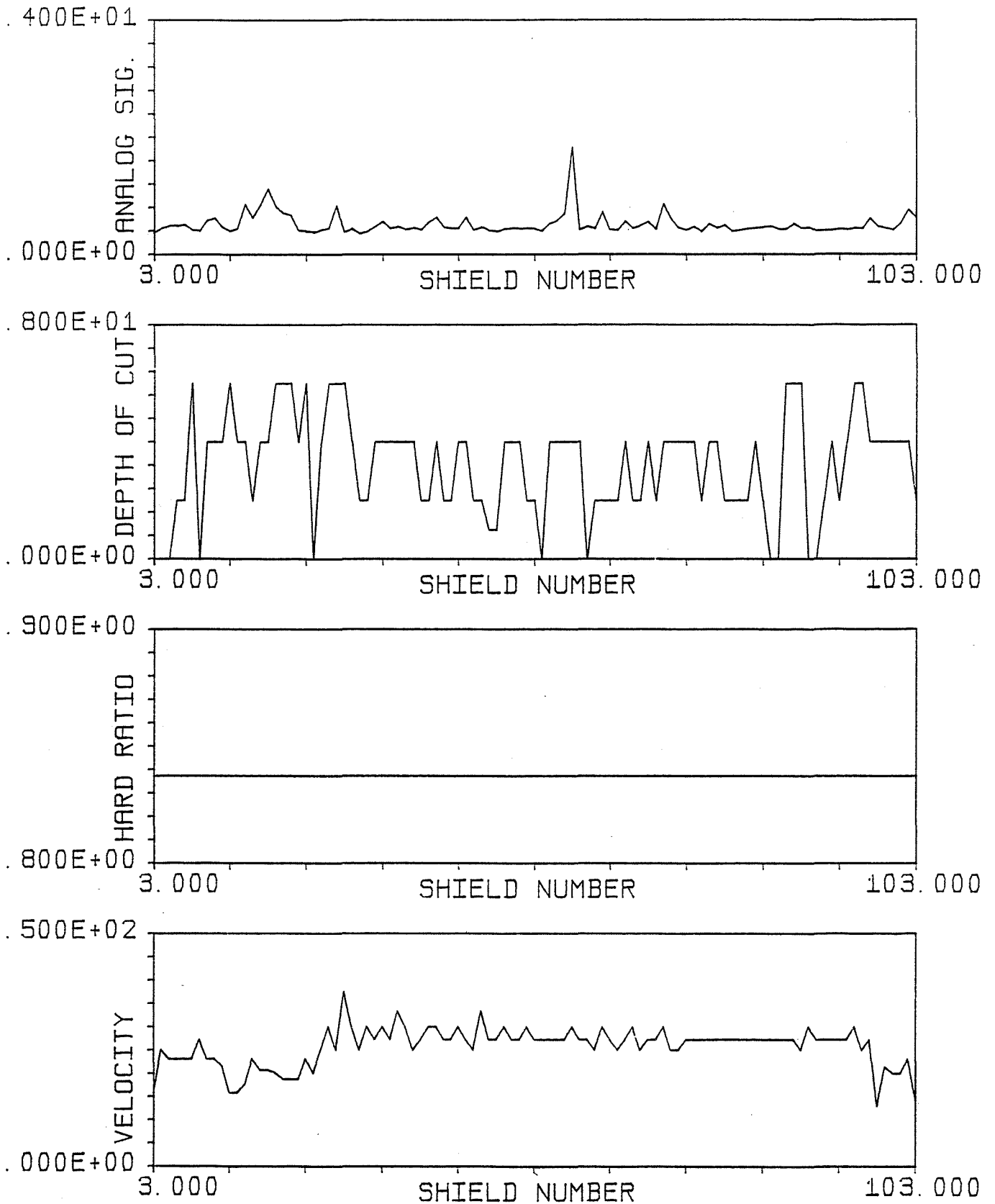

KAISER COAL VIS. #1 PASS#3 H TO T CLEANUP
 DATASET 40

FIGURE 17. Primary Data Plot for Kaiser Coal's Sunnyside Mine

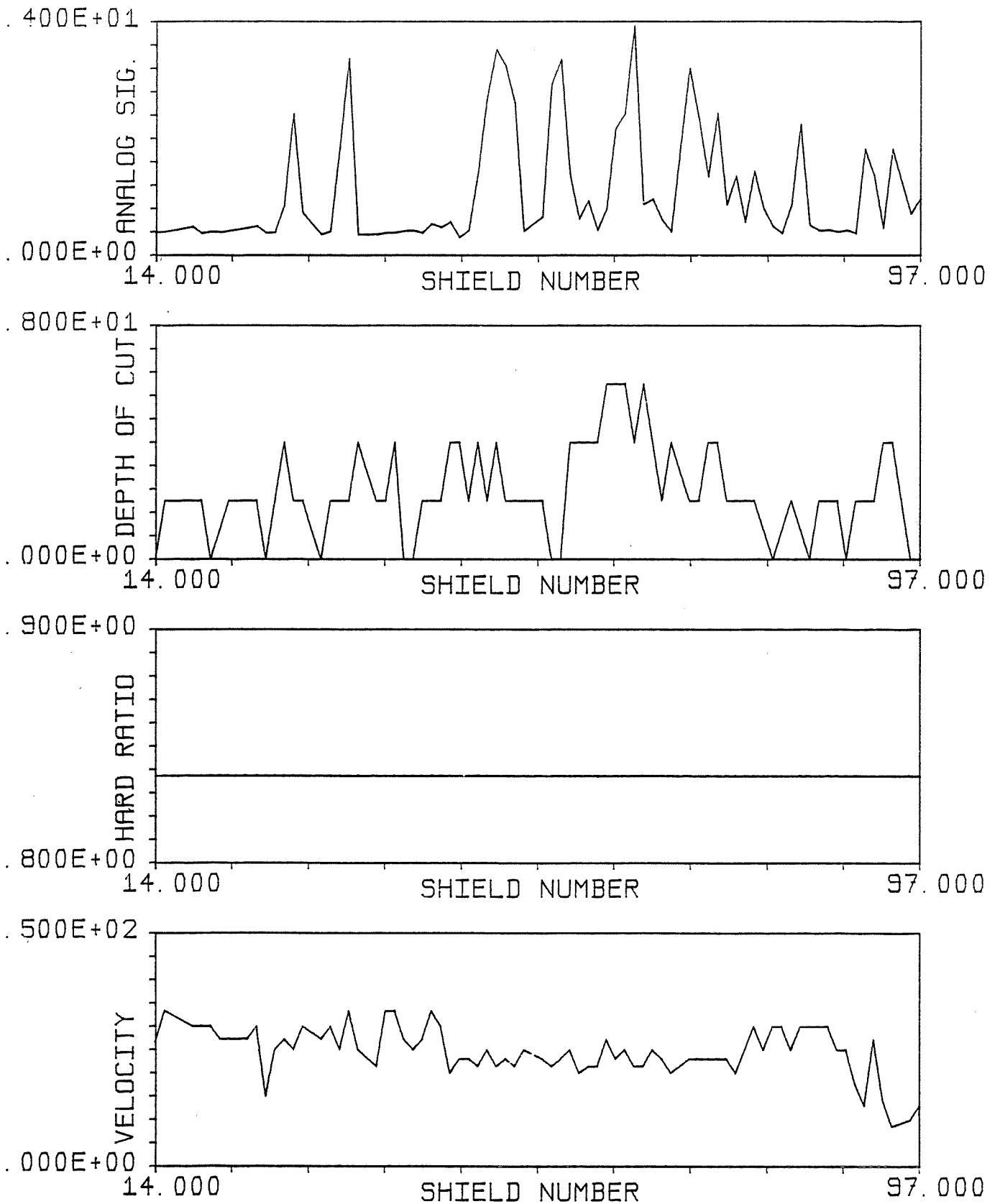

KAISER COAL VIS. #1 PASS#5 H TO T CLEANUP
DATASET 44

FIGURE 18. Primary Data Plot for Kaiser Coal's Sunnyside Mine

TABLE 7. Percentage of Occurrence of Analog Signal for Each Primary Factor,
Kaiser Coal's Sunnyside Mine

KAISER COAL, SUNNYSIDE MINE							
TOTAL NUMBER OF DATA POINTS=426							
			PERCENTAGE	CF	OCCURRENCE		
	ANALOG	SIGNAL	VS.	DEPTH	CF	CUT	
ANALOG SIGNAL=A							
A1: 0<X<1.0				ANALOG	SIGNAL	LEVEL	
A2: 1.0<X<3.0	DEPTH OF CUT	A1	A2	A3	A4	TOTAL	
A3: 3.0<X<5.0	B1	167 (39.20)	4 (0.94)	1 (0.23)	0	172 (40.37)	
A4: 5.0<X<8.0	B2	27 (6.34)	4 (0.94)	0	0	31 (7.28)	
	B3	165 (38.73)	25 (5.87)	5 (1.18)	0	195 (45.78)	
	B4	20 (4.69)	8 (1.88)	0	0	28 (6.57)	
DEPTH OF CUT=B	TOTAL	379 (88.96)	41 (9.63)	6 (1.41)	0	426 (100)	
B1: 0<X<0.1							
B2: 0.1<X<2.0							
B3: 2.0<X<6.0							
B4: 6.0<X<60	ANALOG	SIGNAL	VS.	HARDNESS	RATIO		
HARDNESS RATIO=C							
				ANALOG	SIGNAL	LEVEL	
C1: 0.2<X<0.5	HARDNESS RATIO	A1	A2	A3	A4	TOTAL	
C2: 0.5<X<0.7	C1	0	0	0	0	0	
C3: 0.7<X<0.9	C2	0	0	0	0	0	
C4: 0.9<X<1.2	C3	379 (88.96)	41 (9.63)	6 (1.41)	0	426 (100)	
	C4	0	0	0	0	0	
VELOCITY=D	TOTAL	379 (88.96)	41 (9.63)	6 (1.41)	0	426 (100)	
D1: 0<X<10							
D2: 10<X<20							
D3: 20<X<33.3	ANALOG	SIGNAL	LEVEL	VS.	VELOCITY		
D4: 33.3<X<70							
				ANALOG	SIGNAL	LEVEL	
	VELOCITY	A1	A2	A3	A4	TOTAL	
	D1	4 (0.94)	1 (0.23)	0	0	5 (1.17)	
	D2	149 (34.98)	3 (0.71)	0	0	152 (35.69)	
	D3	218 (51.16)	34 (7.98)	5 (1.18)	0	257 (60.32)	
	D4	8 (1.88)	3 (0.71)	1 (0.23)	0	12 (2.82)	
	TOTAL	379 (88.96)	41 (9.63)	6 (1.41)	0	426 (100)	

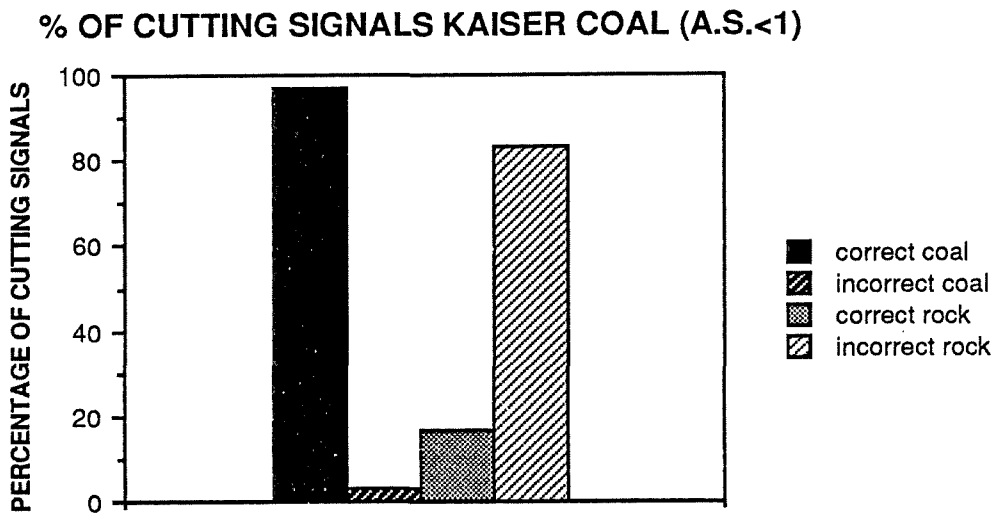

FIGURE 19. Percentage of Correct and Incorrect Coal and Rock Cutting Signals (Analog Signal <1), Kaiser Coal's Sunnyside Mine

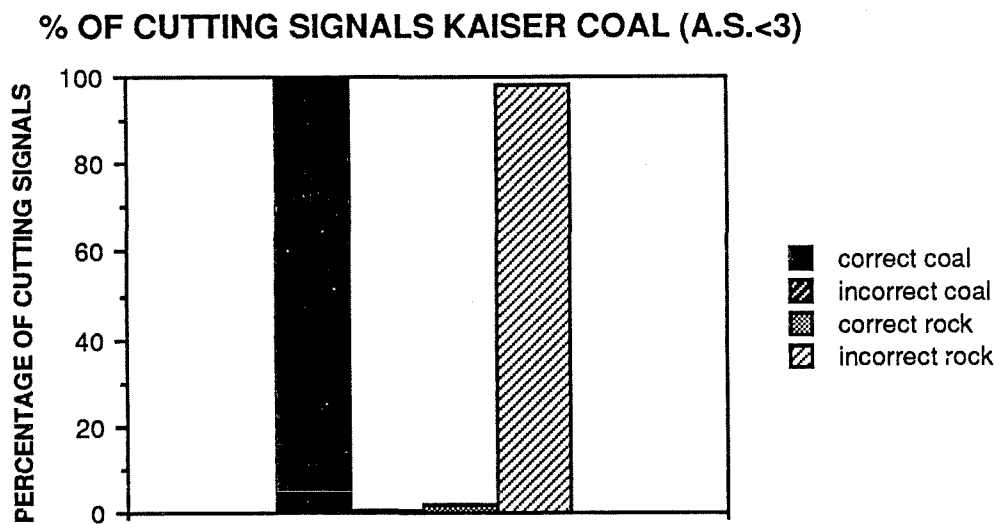

FIGURE 20. Percentage of Correct and Incorrect Coal and Rock Cutting Signals (Analog Signal <3), Kaiser Coal's Sunnyside Mine

% OF CUTTING SIGNALS KAISER COAL (A.S.<5)

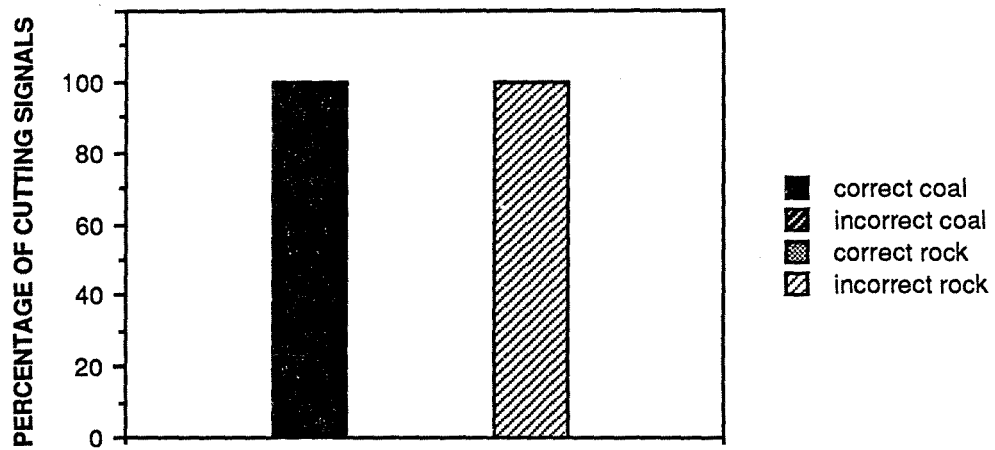

FIGURE 21. Percentage of Correct and Incorrect Coal and Rock Cutting Signals (Analog Signal <5), Kaiser Coal's Sunnyside Mine

Based on the data in Tables 7 and 8 and Figures 19 through 21, the CID does not prove to be effective in distinguishing between the coal and rock horizons at this minesite. The dominant level of analog signal ($0 \leq X < 1$) was found to be associated with both coal and rock cutting. The prevalent hardness ratio encountered was from 0.7 to 0.9. This data closely resembles the data obtained at the Emway Resources mine. As was stated earlier, the analog signal output appears to be influenced by the similarity between the measured coal hardness and rock hardness values. As determined by the analysis of correct cutting signals, the CID proved to be ineffective in determining when the shearer cutting drum had crossed the coal/rock interface.

TABLE 8. Percentage of Occurrence of Each Level of Analog Signal for Each Level of Primary Factor, Kaiser Coal's Sunnyside Mine (Concluded)

KAISER COAL, SUNNYSIDE MINE							
TOTAL NUMBER OF DATA POINTS= 426							
ANALOG SIGNAL = A							
A1: 0<X<1.0	ANALOG	SIGNAL	LEVEL	NUMBER	THREE		
A2: 1.0<X<3.0	FACTORS	C1	C2	C3	C4	TOTALS	
A3: 3.0<X<5.0	B1	0	0	1 (16.67%)	0	1 (16.67%)	
A4: 5.0<X<8.0	B2	0	0	0	0	0	
	B3	0	0	5 (83.33%)	0	5 (83.33%)	
DEPTH OF CUT = B	B4	0	0	0	0	0	
B1: 0<X<0.1	TOTALS	0	0	6 (100%)	0	6 (100%)	
B2: 0.1<X<2.0							
B3: 2.0<X<6.0							
B4: 6.0<X<60							
	FACTORS	D1	D2	D3	D4	TOTALS	
HARDNESS RATIO = C	B1	0	0	1 (16.67%)	0	1 (16.67%)	
C1: 0.2<X<0.5	B2	0	0	0	0	0	
C2: 0.5<X<0.7	B3	0	0	4 (66.66%)	1 (16.67%)	5 (83.33%)	
C3: 0.7<X<0.9	B4	0	0	0	0	0	
C4: 0.9<X<1.2	TOTALS	0	0	5 (83.33%)	1 (16.67%)	6 (100%)	
VELOCITY = D							
D1: 0<X<10.0							
D2:10.0<X<20.0	ANALOG	SIGNAL	LEVEL	NUMBER	FOUR		
D3:20.0<X<33.3							
D4:33.3<X<70.0	FACTORS	C1	C2	C3	C4	TOTALS	
	B1	0	0	0	0	0	
	B2	0	0	0	0	0	
	B3	0	0	0	0	0	
	B4	0	0	0	0	0	
	TOTALS	0	0	0	0	0	
	FACTORS	D1	D2	D3	D4	TOTALS	
	B1	0	0	0	0	0	
	B2	0	0	0	0	0	
	B3	0	0	0	0	0	
	B4	0	0	0	0	0	
	TOTALS	0	0	0	0	0	

NORTH RIVER ENERGY CORPORATION

Figures 22 and 23 are examples of the plots of the primary data collected for two cutting passes at the North River Energy Corporation Mine located in Berry, Alabama. The analog output recorded at this minesite ranged from 0 volts to an output which was less than 5 volts (A_1, A_2, A_3). The dominant level of analog signal is found to be from 0 volts to a value which is less than 3 volts (A_1, A_2) and is found to be associated with coal cutting (B_1) (Figure 22). An analog output of from 3 volts to less than 5 volts (A_3) is obtained when 0.1 to less than 10 inches of rock (B_2, B_3, B_4) is cut (Figure 23).

The hardness ratio measured at this minesite ranged from 0.2 to less than 0.9 (C_1, C_2, C_3). An analog signal level of from 1 to less than 5 volts (A_1, A_2, A_3) is found to occur most frequently with a hardness ratio of from 0.2 to less than 0.7 (Figures 22 and 23).

The prominent operating velocity found at this mine site was from 20 fpm to less than 33.3 fpm (D_3). This level of velocity was found to be strongly associated with a analog signal of 0 volts to 5 volts (A_1, A_2, A_3) (Figure 22).

The data in Table 9 shows the variance of each of the levels of analog signal for each of the levels of primary factors. The percentages discussed in the following text are derived from this table.

The CID proved to be correct approximately 28 percent of the time in detecting when coal was being cut and 90 percent of the time in detecting when rock was being cut, assuming that an analog signal level of less than 1 volt (A_1) is associated with coal cutting (B_1) (Figure 24). The assumption that an analog signal of less than 3 volts (A_1, A_2) is associated with coal cutting (B_1) reveals that the CID was correct for 96 percent of the instances when coal was being cut and 54 percent of the instances when rock was being cut (Figure 25). An assumption that an analog signal of less than 5 volts (A_1, A_2, A_3) is associated with coal cutting (B_1) presents the CID as being effective in 100 percent of the instances where coal was being cut and in 0 percent of the instances where rock was being cut (Figure 26).

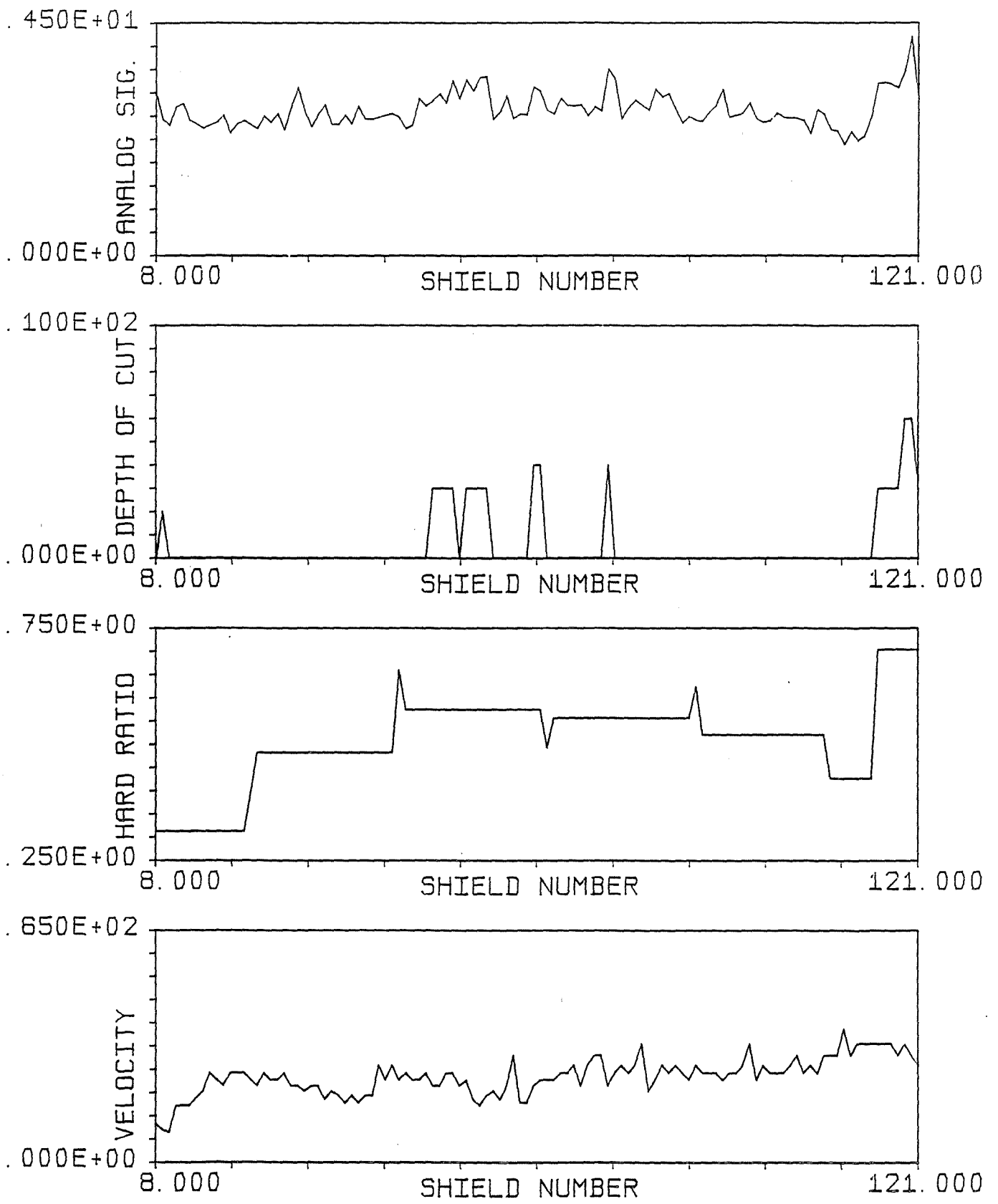

NREC VIS. #2 PASS#2 T TO H CLEANUP
 DATASET 49

FIGURE 22. Primary Data Plot for the North River Energy Corporation Mine

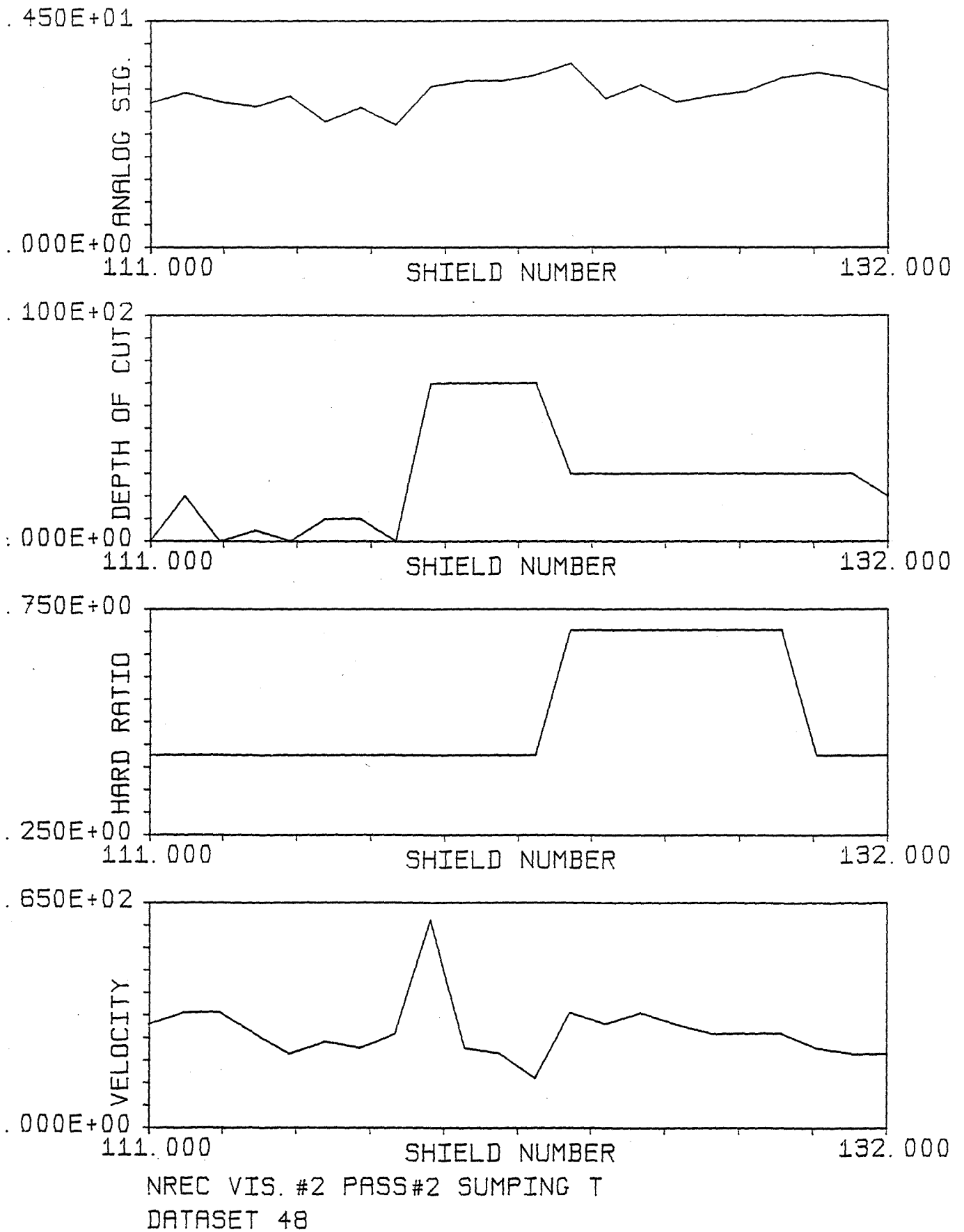

FIGURE 23. Primary Data Plot for the North River Energy Corporation Mine

TABLE 9. Percentage of Occurrence of Analog Signal for Each Primary Factor,
North River Energy Corporation

NORTH RIVER ENERGY CORPORATION							
TOTAL NUMBER OF DATA POINTS=574							
			PERCENTAGE OF		OCURRENCE		
ANALOG SIGNAL=A	ANALOG	SIGNAL	VS.	DEPTH	CF	CUT	
A1: 0<X<1.0				ANALOG	SIGNAL	LEVEL	
A2: 1.0<X<3.0							
A3: 3.0<X<5.0	DEPTH OF CUT	A1	A2	A3	A4	TOTAL	
A4: 5.0<X<8.0	B1	102 (17.76)	244 (42.51)	16 (2.79)		0	362 (63.06)
	B2	10 (1.74)	28 (4.88)	51 (8.89)		0	89 (15.51)
DEPTH OF CUT=B	B3	9 (1.57)	42 (7.32)	56 (9.76)		0	107 (18.65)
B1: 0<X<0.1	B4	2 (0.35)	6 (1.04)	8 (1.39)		0	16 (2.78)
B2: 0.1<X<2.0	TOTAL	123 (21.42)	320 (55.75)	131 (22.83)		0	574 (100)
B3: 2.0<X<6.0							
B4: 6.0<X<60							
	ANALOG	SIGNAL	VS.	HARDNESS	RATIO		
HARDNESS RATIO=C				ANALOG	SIGNAL	LEVEL	
C1: 0.2<X<0.5							
C2: 0.5<X<0.7	HARDNESS RATIO	A1	A2	A3	A4	TOTAL	
C3: 0.7<X<0.9	C1	9 (1.57)	134 (23.34)	41 (7.15)		0	184 (32.06)
C4: 0.9<X<1.2	C2	13 (2.26)	162 (28.23)	79 (13.76)		0	254 (44.25)
	C3	101 (17.59)	24 (4.18)	11 (1.92)		0	136 (23.69)
VELOCITY=D	C4	0	0	0		0	0
D1: 0<X<10	TOTAL	123 (21.42)	320 (55.75)	131 (22.83)		0	574 (100)
D2: 10<X<20							
D3: 20<X<33.3							
D4: 33.3<X<70	ANALOG	SIGNAL	VS.	VELOCITY			
				ANALOG	SIGNAL	LEVEL	
	VELOCITY	A1	A2	A3	A4	TOTAL	
	D1	0	2 (0.35)		0	0	2 (0.35)
	D2	40 (6.97)	41 (7.14)	19 (3.31)		0	100 (17.42)
	D3	77 (13.41)	235 (40.94)	101 (17.60)		0	413 (71.95)
	D4	6 (1.04)	42 (7.32)	11 (1.92)		0	59 (10.28)
	TOTAL	123 (21.42)	320 (55.75)	131 (22.83)		0	574 (100)

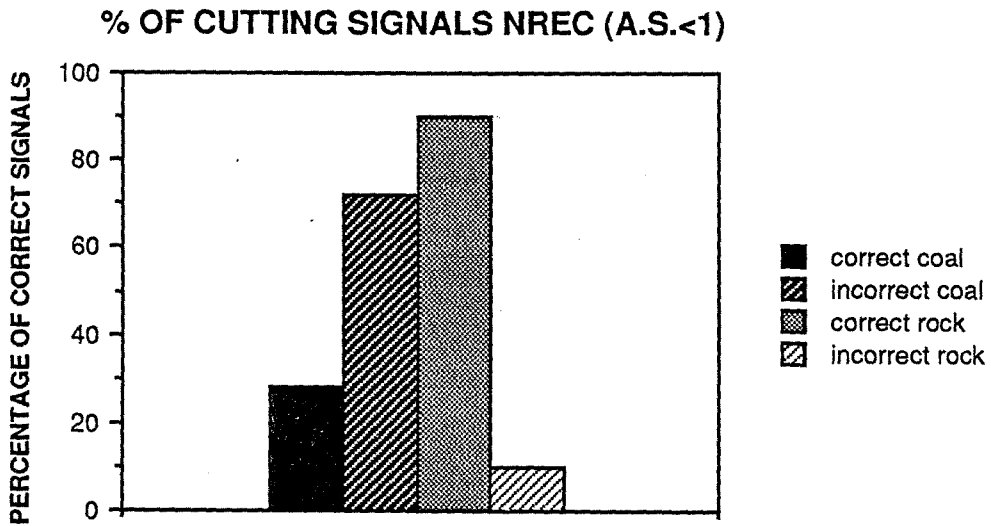

FIGURE 24. Percentage of Correct and Incorrect Coal and Rock Cutting Signals (Analog Signal <1), North River Energy Corporation

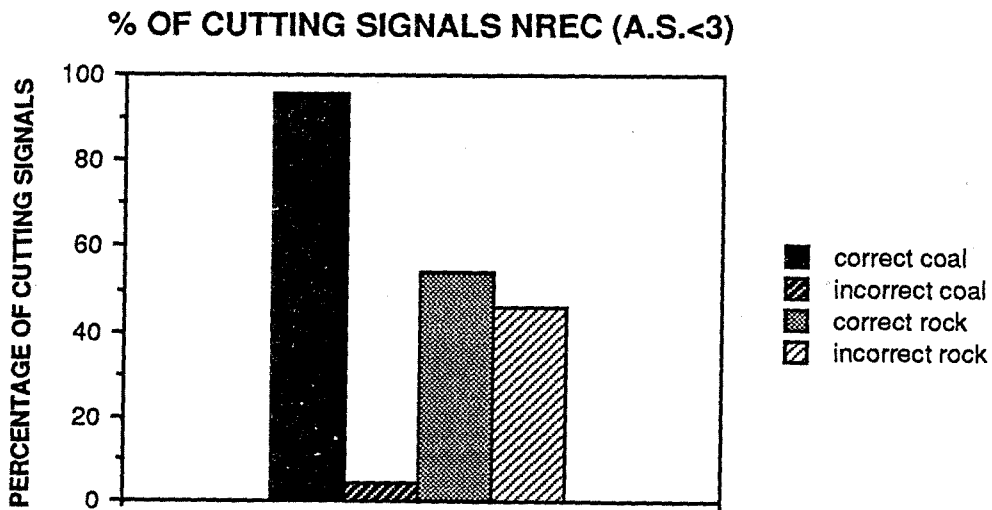

FIGURE 25. Percentage of Correct and Incorrect Coal and Rock Cutting Signals (Analog Signal <3), North River Energy Corporation

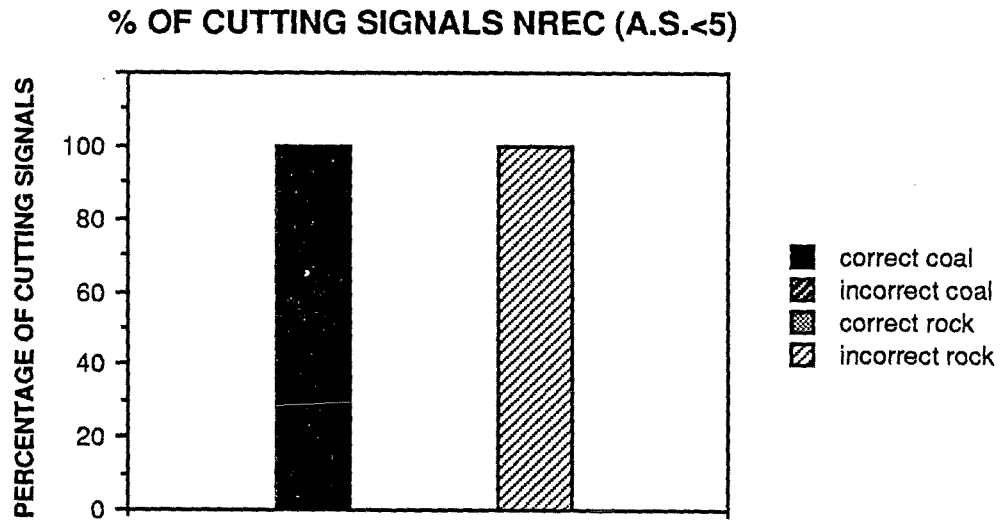

FIGURE 26. Percentage of Correct and Incorrect Coal and Rock Cutting Signals (Analog Signal < 5), North River Energy Corporation

Referring to the data in Tables 9 and 10 and the bar charts shown in Figures 24 through 26, the CID proved to be most effective when the analog voltage assigned to coal cutting was less than 3 volts. The effectiveness of the CID in determining when the coal/rock horizon had been crossed was sustained in over 50 percent of the instances when 0.1 to less than 6 inches of rock was being cut. The level of analog output associated with rock cutting was from 3 volts to a value less than 5 volts.

VII. FACTORIAL ANALYSIS

A factorial experiment is a statistical procedure that efficiently extracts information on several design factors. The main objective is to determine the effect of various factors (independent variables) on some characteristic of a product (dependent variable) of interest.⁶ In this analysis, the independent variables are depth of cut into rock, coal/rock hardness ratio, and shearer velocity. The dependent variable is the CID analog signal output.

The general computational procedure of this multifactor experiment begins by first analyzing the data (shown in Table C, Appendix H) as a two-way classification:

The treatment sum of squares are analyzed into components attributed to the various main effects and interactions. The sum of squares for each main effect is found by adding the squares of the totals corresponding to the different levels of that factor, dividing by the number observations comprising each of these totals and then subtracting the correction term. The sum of squares for any interaction is found by adding the squares of all totals obtained by summing over those subscripts pertaining to factors not involved in the interaction, dividing by the number of observations comprising each of these totals and then subtracting the correction term and all sums of squares corresponding to main effects and fewer-factor interactions involving the factors contained in that interaction."⁷

An example of this computational procedure is shown in Appendix G.

The results of each factorial experiment are summarized in a "ANOVA" (Analysis of Variance) table. Table 11 is an example of an ANOVA table. Directly beneath Table 11 are the formulae used in a factorial experiment. The computed F factor contained in the example table is a test statistic for the hypothesis that there are no significant differences among the means of each factor or that there are no interactions. This hypothesis is rejected if the calculated F factor exceeds the required F factor at a level of significance for a ratio of the degrees of freedom.

$$F_{\text{calc.}} > F_{\text{req.}}$$

⁶ Charles Lipson and Narendra F. Sheth, Statistical Design and Analysis of Engineering Experiments, McGraw-Hill, Inc., New York, 1973, p. 194.

⁷ Irwin Miller and John E. Freund, Probability and Statistics for Engineers, Prentice-Hall, Inc., Englewood Cliffs, N. J., 1965, p. 307.

TABLE 11. Example of an Analysis of Variance (ANOVA) Table Format
(Three-Factor Experiment)

Source	degree of freedom (d.f.)	Sum of Squares	Mean Square	F
Replicate	$r - 1$	SSR	MSR	FR
A	$NLA - 1$	SSA	MSA	FA
B	$NLB - 1$	SSB	MSB	FB
C	$NLC - 1$	SSC	MSC	FC
AB	$(NLA - 1)(NLB - 1)$	SSAB	MSAB	FAB
AC	$(NLA - 1)(NLC - 1)$	SSAC	MSAC	FAC
BC	$(NLB - 1)(NLC - 1)$	SSBC	MSBC	FBC
ABC	$(NLA - 1)(NLB - 1)(NLC - 1)$	SSABC	MSABC	FABC
Error	$(r-1)(NLA \times NLB \times NLC - 1)$	SSE	MSE	

r = replicates

NLA = Number of levels assigned to factor A

NLB = Number of levels assigned to factor B

NLC = Number of levels assigned to factor C

C = Correction term = $G^2 / (NLA \times NLB \times NLC)$

* G = Grand total of all observations

SST = Sum of Squares of the Total = $\sum_i \sum_j \sum_k \sum_l y_{ijkl}^2 - C$

SSR = Sum of Squares of the Replicates = $(1/(NLA \times NLB \times NLC)) \sum_i R_i^2 - C$

SSA = Sum of Squares of Factor A = $(1/(r \times NLB \times NLC)) \sum_j A_j^2 - C$

SSB = Sum of Squares of Factor B = $(1/(r \times NLA \times NLC)) \sum_k B_k^2 - C$

SSC = Sum of Squares of Factor C = $(1/(r \times NLA \times NLB)) \sum_l C_l^2 - C$

$SSAB$ = Sum of Squares of the AB interaction =
 $(1/(r \times NLC)) \sum_j \sum_k T_{jk}^2 - C - SSA - SSB$

$SSAC$ = Sum of Squares of the AC interaction =
 $(1/(r \times NLB)) \sum_j \sum_l T_{jl}^2 - C - SSA - SSC$

$SSBC$ = Sum of Squares of the BC interaction =
 $(1/(r \times NLA)) \sum_k \sum_l T_{kl}^2 - C - SSB - SSC$

$SSABC$ = Sum of Square of the ABC interaction =
 $(1/r) \sum_j \sum_k \sum_l T_{jkl}^2 - C - SSA - SSB - SSC - SSAB - SSAC - SSBC$

SSE = Sum of Square of the Error =
 $SST - SSR - SSA - SSB - SSC - SSAB - SSAC - SSBC - SSABC$

* Mean Squares are obtained by dividing the sums of squares by their associated degrees of freedom.

* MSE serves as a denominator of all F ratios.

The presence of interactions are of particular interest. When two factors do not behave independently, they are said to be interactive. When two factors interact, the response in changes in one factor is conditioned by the level of another factor.⁸

The interpretation of the results of the ANOVA table depends on the outcome of the significance tests. The interpretation begins by first considering the significance of the four-factor interaction. If it is significant, none of the factors are acting independently. In this case, the results may be summarized in a four-way table. If the four-way interaction is not significant, we look at the three-factor interaction. If it is significant, we summarize the results in a three-way table. This process is followed until significance is found at some level of interaction or in the main effects. When an interaction is found to be significant, the lower order interactions and main effects will not be investigated. The interaction indicates a dependence of one factor on one or more other factors.⁹

The following analysis is comprised of three factorial experiments: 1) the percentage of cutting signals overall, 2) the percentage of coal cutting signals, and 3) the percentage of rock cutting signals. In these experiments, the treatments consisted of the combinations of four factors. These factors are CID analog signal, depth of cut into rock, coal/rock hardness ratio, and shearer velocity. The combinations are such that each level of every factor occurs together with each level of every other factor. The percentage of occurrence of each of these combinations was calculated and presented as output by the computer program (Appendix E) which was written to support this data analysis procedure.

An analysis of the percentage of correct cutting signals was conducted for each factorial experiment. A summary table was prepared from the data contained in the two tables' (Tables C and D) output from the computer program. This table contains the number of occurrences of each level of analog signal for each of the levels of the primary factors. A level of analog signal was assigned to either coal or rock cutting, and the percentage of correct occurrences were calculated.

⁸ Roger G. Petersen, Design and Analysis of Experiments, Marcel Dekker, Inc., New York, 1985, p. 116.

⁹ Ibid, p. 129.

Throughout this section of the report, the factors involved in the factorial experiment and in the percentage of correct cutting signals will be referred to in the following manner.

- Factor A - Analog signal
- Factor B - Depth of cut into rock
- Factor C - Coal/rock hardness ratio
- Factor D - Shearer velocity

Each of the measured factors was grouped into four class intervals or levels. The subscript following the variables refers to the level of the factor. For example, A_1 refers to the first level of the analog signal and, likewise, AB_{12} refers to the first level of analog signal and second level of depth of cut.

In order to explain the significant interactions, the values from Table C1 (Appendix H) of the computer output were summarized in tabular form (Table 13). The data was normalized and profiles were developed for all significant interactions. As a computational aid, an additional F test was conducted on each analog signal subset of the summary table in order to explain the source of factor dependency. This was achieved by calculating the simple effects that the levels of a factor had on each of the levels of analog signal. The following formulae will be used throughout the analysis section.

Simple Effect Formulas

$$^{10} *SS_{B \text{ at } A_i} = \frac{AB_{11}^2 + AB_{12}^2 + AB_{13}^2 + AB_{ij}^2}{n \times N.L.A} - \frac{(\sum AB_{ij})^2}{N.L.A. \times N.L.B \times n}$$

$SS_{B \text{ at } A_i}$ = The sum of squares of all levels of B with Level A_i

n = Number of observations under each treatment condition.

N.L.A = Number of levels of Factor A

N.L.B = Number of levels of Factor B

$$^{11} *MS_{B \text{ for } A_i} = \frac{SS_{B \text{ at } A_i}}{\text{No. of d.f. of Factor B}}$$

$MS_{B \text{ for } A_i}$ = Mean square of the simple effects of Factor B for level i of A

d.f. = degree of freedom

$$^{12} *F = \frac{MS_{B \text{ for } A_i}}{MSE}$$

MSE = Mean square error term for Table 11

F = Test for the significance of the effects of the levels of Factor B for each level of Factor A.

¹⁰ B. J. Winer, McGraw-Hill Series in Psychology, McGraw-Hill, Inc., New York, 1962, p. 256.

¹¹ Ibid.

¹² Ibid.

PERCENTAGE OF CUTTING SIGNALS OVERALL

In this factorial experiment, we will analyze the effect that depth of cut (B), hardness ratio (C), and velocity (D) have on the analog signal (A) for all of the data. The experiment was replicated four times, and each replicate represents the data collected at one of the participating mines. The variable ranges assigned to the factor levels are:

Analog Signal (A)

A_1	$0 \leq x < 1$
A_2	$1 \leq x < 3$
A_3	$3 \leq x < 5$
A_4	$5 \leq x < 8$

Depth of Cut (B)

B_1	$0 \leq x < 0.1$
B_2	$0.1 \leq x < 2$
B_3	$2 \leq x < 6$
B_4	$6 \leq x < 60$

Hardness Ratio (C)

C_1	$0.2 \leq x < 0.5$
C_2	$0.5 \leq x < 0.7$
C_3	$0.7 \leq x < 0.9$
C_4	$0.9 \leq x < 1.2$

Velocity (D)

D_1	$0 \leq x < 10$
D_2	$10 \leq x < 20$
D_3	$20 \leq x < 33.3$
D_4	$33.3 \leq x < 70$

Replications

- *Replication 1 - Jim Walter Resources, No. 3 Mine
- *Replication 2 - Emway Resources, Emerald No. 1 Mine
- *Replication 3 - Kaiser Coal, Sunnyside Mine
- *Replication 4 - North River Energy Corporation

A preliminary analysis of variance is given in Table 12 for the data in Table C1 (Appendix H). The preliminary analysis of variance indicates that the three-factor interaction between analog signal (A) X depth of cut (B) X hardness (C) is significant at a 10-percent level of confidence.

$$F \text{ calc.} = 1.401$$

$$\text{Freq. (0.1, 27, 765)} = 1.374$$

$$F \text{ calc.} > \text{Freq.}$$

Therefore the main effects and two-factor interactions involving these factors will not be considered in this discussion.

Table 12 also indicates that the two-factor interaction between analog signal (A) X velocity (D) is significant at a 0.5-percent level of confidence.

$$F \text{ calc.} = 26.17$$

$$\text{Freq. (0.005, 9, 765)} = 2.65$$

$$F \text{ calc.} > \text{Freq.}$$

Since the velocity factor was not involved in the three-factor interaction, we will investigate this significant interaction.

TABLE 12. Analysis of Variable Table (ANOVA) for Percentage of Cutting Signals Overall

E. STATISTICAL ANALYSIS

SOURCE OF VARIATION	D O F	SUM OF SQUARES	MEAN SQUARE	F FACTOR
-----	-----	-----	-----	-----
REPLICATES	3.000	.1078E+05	3594.	7.069
MAIN EFFECTS				
FACTOR 1.	3.000	.4240E+05	.1413E+05	27.80
2.	3.000	5078.	1693.	3.330
3.	3.000	.1953E+05	6510.	12.81
4.	3.000	-.9000E+05	-.3000E+05	-59.01
TWO FACTOR INTERACTION				
1, 2.	9.000	.1101E+05	1223.	2.406
1, 3.	9.000	.3921E+05	4357.	8.570
1, 4.	9.000	.1198E+06	.1331E+05	26.17
2, 3.	9.000	1016.	112.8	.2220
2, 4.	9.000	.1099E+06	.1221E+05	24.03
3, 4.	9.000	.1136E+06	.1262E+05	24.83
THREE FACTOR INTERACTION				
1, 2, 3.	27.00	.1923E+05	712.1	1.401
1, 2, 4.	27.00	-.1008E+06	-3734.	-7.346
1, 3, 4.	27.00	-.8420E+05	-3119.	-6.135
2, 3, 4.	27.00	-.1029E+06	-3811.	-7.496
FOUR FACTOR INTERACTION				
1, 2, 3, 4.	81.00	-.9205E+05	-1136.	-2.235
ERROR	765.0	.3889E+06	508.4	1.000

Three-Factor Interaction: Analog Signal (A) X (Depth) of Cut (B) X Hardness Ratio (C)

The results of the factorial experiment for this significant interaction are summarized in Table 13. A geometric representation of the data contained in Table 13 is shown in Figures 27a through 27d, which are profiles of the simple effects of the depth of cut at each of the levels of analog signal for a respective hardness ratio. The marked differences in the simple effect indicate that the simple effect interactions are not zero. To determine the significance of the simple effect interactions, an F test was conducted on the subset of analog signal for each level of hardness ratio. The results of these computations are shown in Tables 15a through 15d.

For the first level of hardness ratio, we examine Table 15a and Figure 27a. A_2 tests to be significant at the 0.5-percent level of significance. Observing the profile for this interaction, we find A_2 to occur most frequently with B_1 . The test on the simple effects on the other levels of analog signal indicate no significant difference between levels of depth of cut.

Observation of Table 15b and Figure 27b for the second level of hardness ratio indicates that Factor A_1 tests to be significant at a 5-percent level of confidence and is strongly associated with B_1 . The test on the simple effect of the remaining levels of analog signal show that there is no significant difference in the occurrence of these levels with any level of depth of cut.

The simple effect interaction between analog signal and depth of cut at level 3 of the hardness ratio tests to be significant at three levels of the analog signal. From Table 15c and Figures 27c, we find that A_1 is significant at a 0.5-percent level of confidence and appears to be equally associated with B_1 and B_3 . A_2 is found to be significant at a 10-percent level of confidence and is also correlated with level B_1 and B_3 . A_3 tests to be significant at a 0.5-percent level of confidence and is strongly associated with B_4 .

Based on this statistical analysis, it appears that the CID was effective at a level 3 hardness ratio. Further analysis of Figure 27c reveals that analog signal A_1 was output more frequently than analog signal level A_3 at a depth-of-cut level B_4 . In fact, analog level A_1 is found to be the dominant analog output for all levels of depth of cut. Based on this observation, the CID does not demonstrate effectiveness at this level of hardness ratio. The coal and rock hardness values are very similar in this

ANAL. SIG. PRO. FOR D.O.C.,LEV. 1 H.R.,ALL DATA

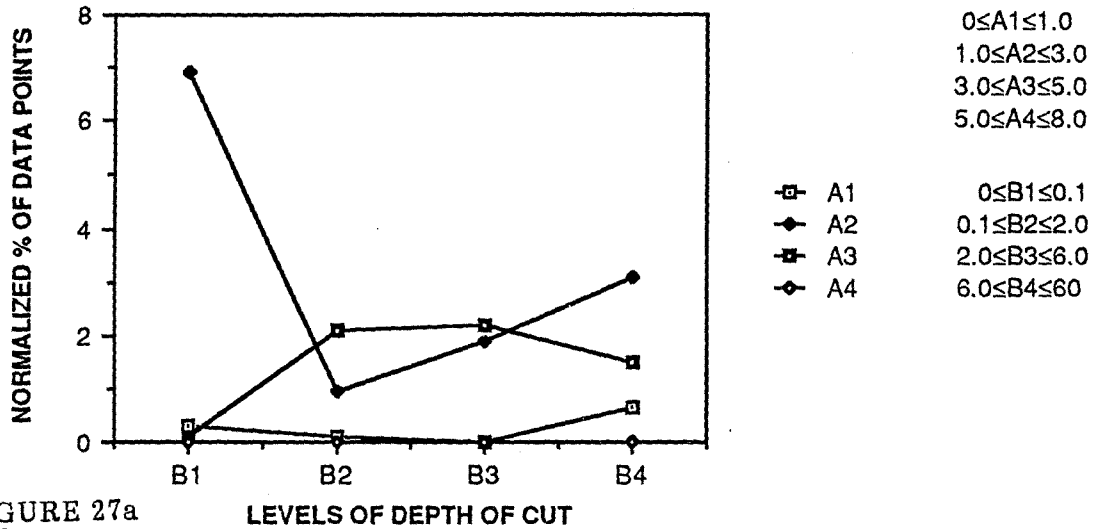

FIGURE 27a

ANAL. SIG. PRO. FOR D.O.C.,LEV. 2 H.R.,ALL DATA

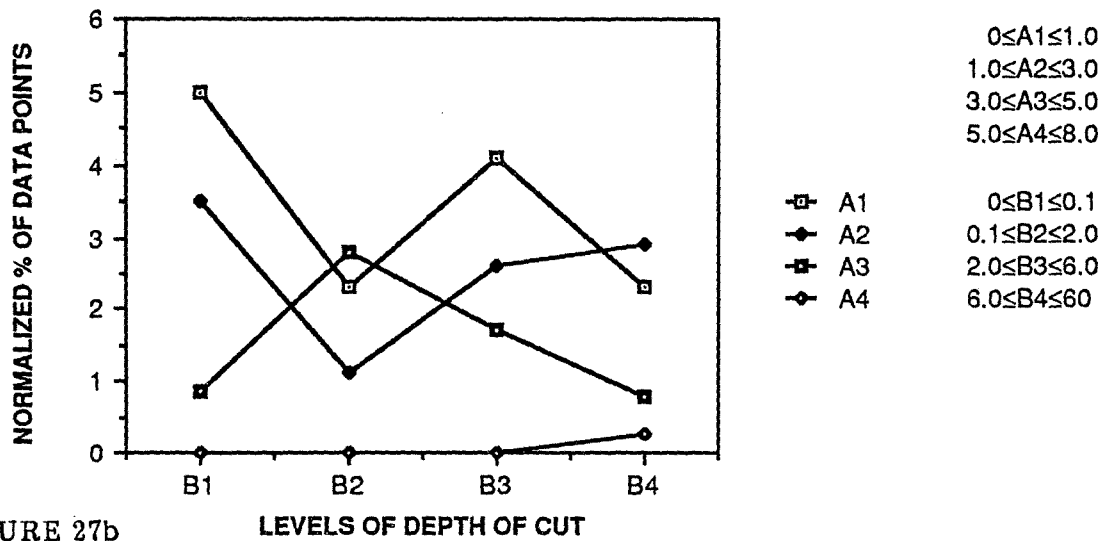

FIGURE 27b

FIGURES 27a and 27b. Profiles of Each of the Levels of Analog Signal for the Levels of Depth of Cut at a) Hardness Ratio Level 1 and b) Hardness Ratio Level 2 for the Percentage of Cutting Signals Overall

ANAL. SIG. PRO. FOR D.O.C.,LEV. 3 H.R.,ALL DATA

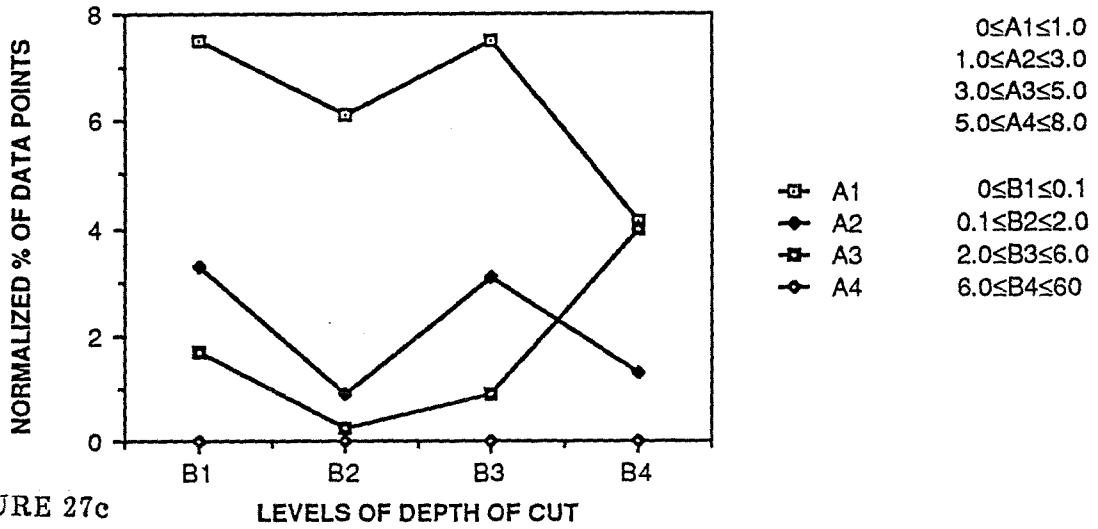

FIGURE 27c

ANAL. SIG. PRO. FOR D.O.C.,LEV. 4 H.R.,ALL DATA

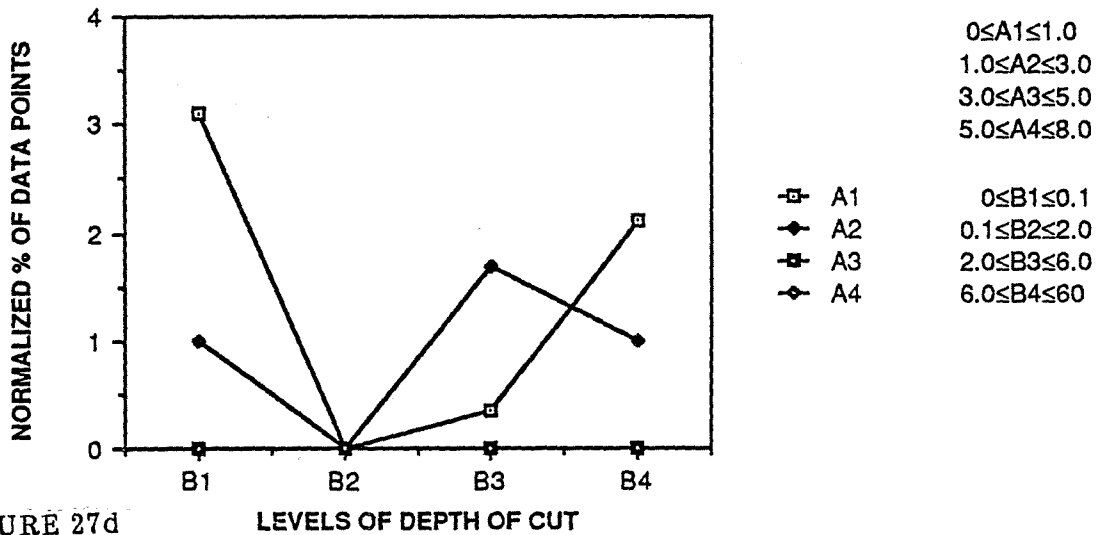

FIGURE 27d

FIGURES 27c and 27d. Profiles of Each of the Levels of Analog Signal for the Levels of Depth of Cut at c) Hardness Ratio Level 3 and d) Hardness Ratio Level 4 for the Percentage of Cutting Signals Overall

TABLE 14

Freq. for the Factors Involved in the Coal and Rock Cutting Factorial Experiment

D.F.S.V./D.F.M.S.E.	LEVELS		CF	SIGNIFICANCE		
	10%	5%	2.50%	1%	0.50%	
3/765	2.09	2.615	3.135	3.81	4.32	
9/765	1.635	1.895	2.135	2.435	2.65	
27/765	1.374	1.505	1.619	1.765	1.873	
81/765	1.224	1.295	1.36	1.463	1.495	

D.F.S.V. = Degrees of Freedom for the Source of Variation

D.F.M.S.E. = Degrees of Freedom for the Mean Square Error

TABLE 15a

Summary of the Simple Effects of Depth of Cut (B) on Analog Signal (A) at Level 1 of the Hardness Ratio (C)

S.E. CALC.	LEVELS		CF	ANALOG		SIGNAL	
	A1	A2	A3	A4			
SSBAi	147.93	11788.74	1626.88	0			
MSBAi	49.31	3929.58	542.29	0			
Fcalc.	0.097	7.7293	1.0667	0			
LEVEL OF SIG.	NOT SIG.	0.50%	NOT SIG.	NOT SIG.			

S.E. CALC. = Simple Effects Calculations

SSBAi = Sum of Squares for the levels of Factor B for each level of Factor A

MSBAi = Mean Square for the levels of Factor B for each level of Factor A

Fcalc. = Calculated F factor

TABLE 15b

Summary of the Simple Effects of Depth of Cut (B) on Analog Signal (A) at Level 2 of the Hardness Ratio (C)

S.E. CALC.	LEVELS		CF	ANALOG		SIGNAL	
	A1	A2	A3	A4			
SSBAi	3063.2	1927.33	1605.03	27.25			
MSBAi	1021.07	642.44	535.01	9.08			
Fcalc.	2.0084	1.2637	1.0523	0.0179			
LEVEL OF SIG.	5%	NOT SIG.	NOT SIG.	NOT SIG.			

S.E. CALC. = Simple Effects Calculations

SSBAi = Sum of Squares for the levels of Factor B for each level of Factor A

MSBAi = Mean Square for the levels of Factor B for each level of Factor A

F calc. = Calculated F factor

TABLE 15c

Summary of the Simple Effects of Depth of Cut (B) on Analog Signal (A) at Level 3 of the Hardness Ratio (C)

S.E. CALC.	LEVELS	CF	ANALOG	SIGNAL	
	A1	A2	A3	A4	
SSBAi	4428.83	2575.09	4481.17		0
MSBAi	1476.28	858.36	1493.72		0
Fcalc.	2.9083	1.6884	2.9381		0
LEVEL OF SIG.	0.50%	10%	0.50%		NOT SIG.

S.E. CALC. = Simple Effects Calculations

SSBAi = Sum of Squares for the levels of Factor B for each level of Factor A

MSBAi = Mean Square for the levels of Factor B for each level of Factor A

Fcalc. = Calculated F factor

TABLE 15d

Summary of the Simple Effects of Depth of Cut (B) on Analog Signal (A) at Level 4 of the Hardness Ratio (C)

S.E. CALC.	LEVELS	CF	ANALOG	SIGNAL	
	A1	A2	A3	A4	
SSBAi	3772.54	883.01	0		0
MSBAi	1257.51	294.34	0		0
Fcalc.	2.4735	0.5789	0		0
LEVEL OF SIG.	1%	NOT SIG.	NOT SIG.		NOT SIG.

S.E. CALC. = Simple Effects Calculations

SSBAi = Sum of Squares for the levels of Factor B for each level of Factor A

MSBAi = Mean Square for the levels of Factor B for each level of Factor A

Fcalc. = Calculated F factor

interval of hardness ratio. This may explain the high frequency of occurrence of analog signal level 1 with all levels of depth of cut.

At the fourth level of hardness ratio, we find that level A_1 tests to be significant at the 1-percent level of confidence. From Figure 27d we see that A_1 can be expected to occur with level B_1 and B_4 .

At this level of hardness ratio the coal hardness is either equal to or greater than the hardness of the rock stratum. This appears to account for the dominance of level A_1 of the analog signal.

Two-Factor Interaction Analog Signal (A) X Velocity (D)

Summary Table 16 presents the results for all treatment conditions of this two-factor interaction. The profiles of each of the levels of analog signal for the levels of velocity are shown in Figure 28. The marked differences in the profiles signify that the levels of velocity had a different effect on each of the levels of analog signal. To test whether the differences of these effects were significant, F tests were conducted on the data in Table 16. The results shown in Table 18 reveal that there was a significant difference in the levels of velocity for analog signal levels A_1 , A_2 , and A_3 .

Levels A_1 and A_2 are significant at the 0.5-percent level of confidence while level A_3 tests to be significant at the 2.5-percent level of confidence. From Figure 28, we can see that the magnitude of the analog signal increased as the velocity increased. This increase may be attributed to velocity being a component of the force attributed to the cutting action.

TABLE 16
Summary Table for the Two Factor Interaction Involving
Analog Signal and Velocity for All Data Points

	A1	A2	A3	A4
D1	300	220	80	0
D2	1653.82	775.68	470.59	0
D3	1368.73	1319.91	592.03	19.35
D4	1044.36	1081.66	669.22	4.76

ANALOG SIGNAL PRO. FOR LEV. OF VELOCITY, ALL DATA

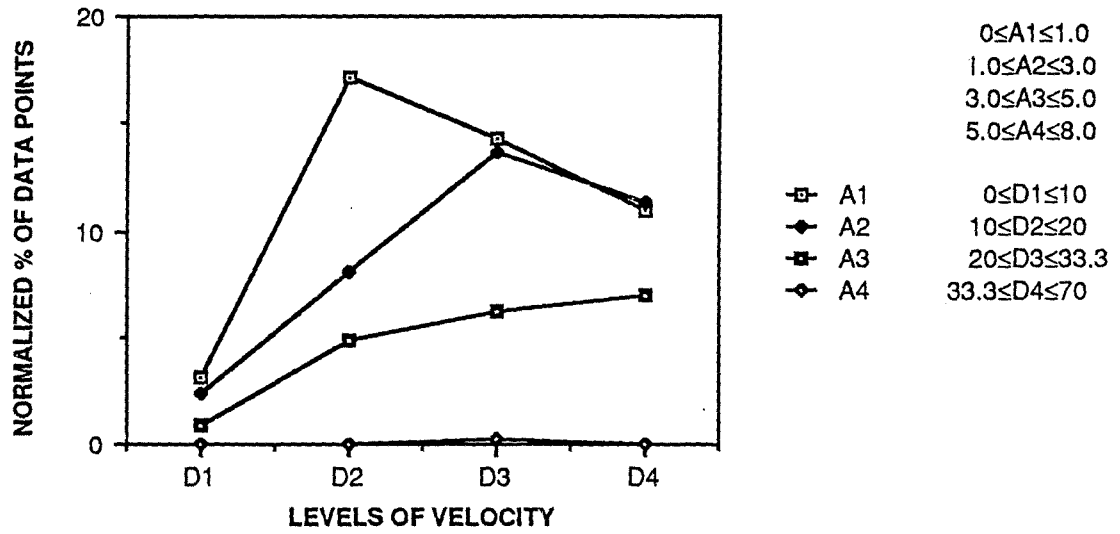

FIGURE 28. Profiles of Each of the Levels of Analog Signal for the Levels of Velocity for the Percentage of Cutting Signals Overall

TABLE 17

Freq. for the Factors Involved in the Coal and Rock Cutting Factorial Experiment

D.F.S.V/D.F.M.S.E.	LEVELS		CF	SIGNIFICANCE		
	10%	5%		2.50%	1%	0.50%
3/765	209%	2.615	3.135	3.81	4.32	
9/765	164%	1.895	2.135	2.435	2.65	
27/765	1.374	1.505	1.619	1.765	1.873	
81/765	1.224	1.295	1.36	1.463	1.495	

D.F.S.V. = Degrees of Freedom for the Source of Variation
 D.F.M.S.E. = Degrees of Freedom for thr Mean Square Error

TABLE 18

Summary of the Simple Effects of Velocity (D) on Analog Signal (A) for Coal and Rock Cutting

S.E. CALC.	LEVELS		CF	ANALOG		SIGNAL	
	A1	A2		A3	A4		
SSDAi	15964.91	10576.61	3211.23	3.93			
MSDAi	5321.64	3525.54	1070.41	1.31			
Fcalc.	10.4674	6.9346	2.1054	0.0026			
LEVEL OF SIG.	0.50%	0.50%	5%	NOT SIG.			

S.E. CALC. = Simple Effects Calculations
 SSDAi = Sum of the Squares of the levels of Factor D for each of the levels of Factor A
 MSDAi = Mean Square for the levels of Factor D for each level of Factor A
 Fcalc. = Calculated F factor

Percentage of Correct Coal and Rock Cutting Signals (All Data Points)

Table 19 is a summary table that relates the number of times each of the levels of analog signal (A) occurred for each of the levels of the primary factors (i.e., depth of cut into rock (B), coal/rock hardness ratio (C), shearer velocity (D)). This table consists of all the primary data collected during the data acquisition phase of the project.

The effectiveness of the CID was determined by assigning a range of analog signal data to coal cutting and then calculating the percentage of correct output for both coal and rock cutting. These percentages were calculated from the values shown in Table 19.

Assigning an analog signal level of less than 1 volt to coal cutting results in the CID being effective in approximately 51 percent of the cases where coal was being mined and in 48 percent of the instances where rock was being cut (Figure 29a). Assigning a greater level of analog signal to coal cutting leads to an increase in the percentage of correct signals for coal cutting and a decrease in the percentage of correct rock cutting signals. For the assumption that coal cutting would result in an analog signal of less than 3 volts, it is found that the percentage of correct coal cutting signals is approximately 94 percent and the percentage of correct rock cutting signals is approximately 23 percent (Figure 29b). Figure 29c depicts the consequences of assigning an analog signal of less than 5 volts to coal cutting. Therefore, from Table 19 and Figures 29a through 29c it appears that, at best, the CID was approximately 50-percent effective in determining when the coal/rock horizon had been traversed.

TABLE 19. Percentage of Occurrence of Analog Signal for Each Primary Factor, Coal and Rock Cutting (All Data Points)

COAL AND ROCK CUTTING, ALL DATA							
TOTAL NUMBER OF DATA POINTS=2477							
PERCENTAGE OF OCCURRENCE							
ANALOG SIGNAL VS. DEPTH OF CUT							
ANALOG SIGNAL=A							
A1: 0<X<1.0							
A2: 1.0<X<3.0							
A3: 3.0<X<5.0							
A4: 5.0<X<8.0							
ANALOG SIGNAL LEVEL							
DEPTH OF CUT	A1	A2	A3	A4	TOTAL		
B1	663 (26.76)	545 (22.00)	80 (3.23)		0	1288	(51.99)
B2	51 (2.06)	38 (1.53)	54 (2.19)		0	143	(5.78)
B3	340 (13.73)	152 (6.14)	93 (3.75)		0	585	(23.62)
B4	230 (9.29)	106 (4.28)	117 (4.72)	8 (0.32)		461	(18.61)
TOTAL	1284 (51.84)	841 (33.95)	344 (13.89)	8 (0.32)		2477	(100)
ANALOG SIGNAL VS. HARDNESS RATIO							
HARDNESS RATIO=C							
ANALOG SIGNAL LEVEL							
HARDNESS RATIO	A1	A2	A3	A4	TOTAL		
C1	22 (0.89)	290 (11.71)	41 (1.66)		0	353	(14.26)
C2	407 (16.43)	424 (17.12)	170 (6.86)	8 (0.32)		1009	(40.73)
C3	810 (32.70)	114 (4.60)	133 (5.37)		0	1057	(42.67)
C4	45 (1.82)	13 (0.52)		0	0	58	(2.34)
TOTAL	1284(51.84)	841 (33.95)	344 (13.89)	8 (0.32)		2477	(100)
ANALOG SIGNAL VS. VELOCITY							
ANALOG SIGNAL LEVEL							
VELOCITY	A1	A2	A3	A4	TOTAL		
D1	8 (0.32)	3 (0.12)	4 (0.16)		0	15	(0.60)
D2	296 (11.95)	101 (4.08)	81 (3.27)		0	478	(19.30)
D3	799 (32.26)	568 (22.93)	184 (7.43)	6 (0.24)		1557	(62.86)
D4	181 (7.31)	169 (6.82)	75 (3.03)	2 (0.08)		427	(17.24)
TOTAL	1284 (51.84)	841 (33.95)	344 (13.89)	8 (0.32)		2477	(100)

39

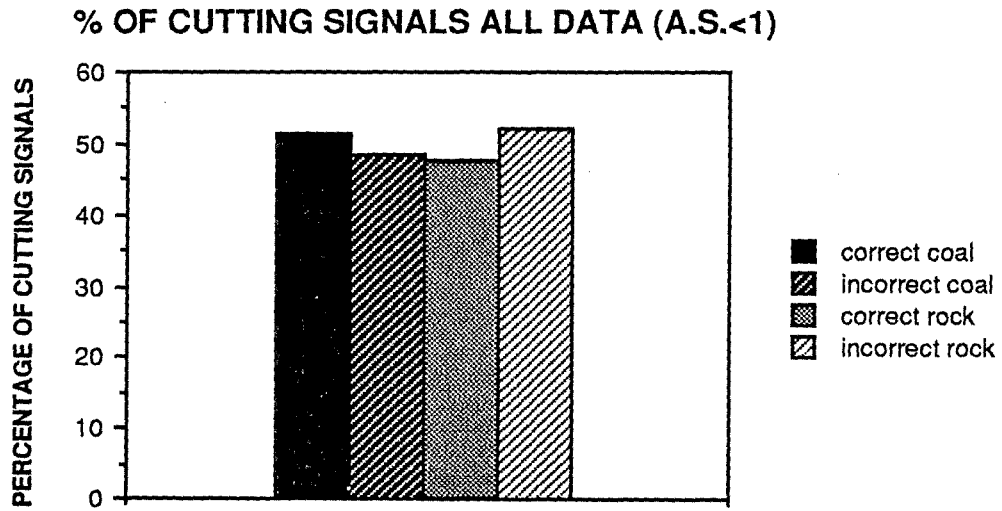

FIGURE 29a. Percentage of Correct and Incorrect Coal and Rock Cutting Signals (Analog Signal <1), All Data Points

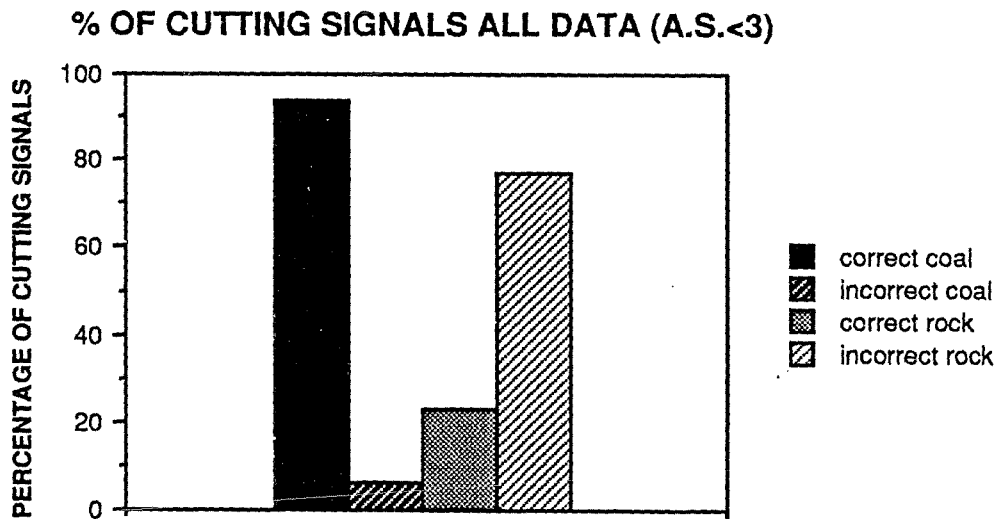

FIGURE 29b. Percentage of Correct and Incorrect Coal and Rock Cutting Signals (Analog Signal <3), All Data Points

% OF CUTTING SIGNALS ALL DATA (A.S.<5)

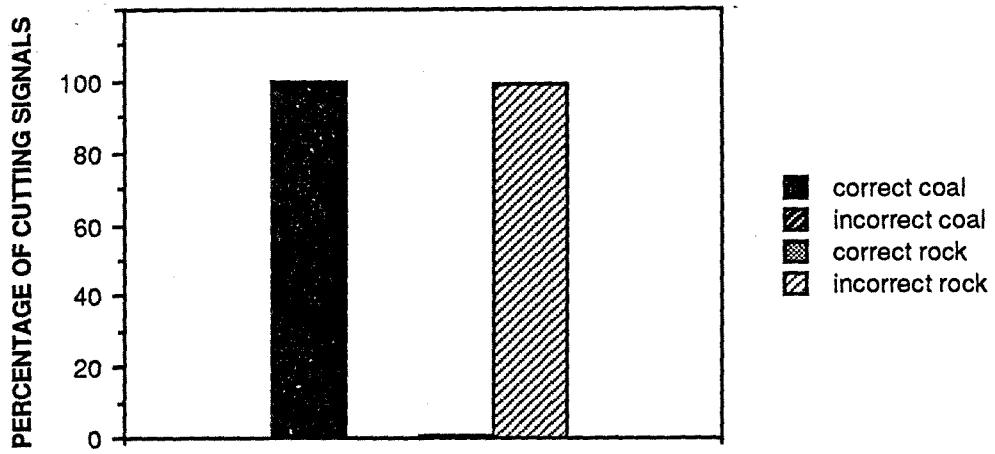

FIGURE 29c. Percentage of Correct and Incorrect Coal and Rock Cutting Signals (Analog Signal <5), All Data Points

PERCENTAGE OF CUTTING SIGNALS WHEN CUTTING ROCK

This investigation was made to determine the effects that depth of cut, hardness ratio, and velocity had on the output of the CID for cutting rock. The experiment consisted of four replications with each replication representing the data collected at one of the participating mine sites. The variable ranges assigned to the four factors chosen for this experiment are:

Analog Signal (A)

A_1	$0 \leq x < 1$
A_2	$1 \leq x < 3$
A_3	$3 \leq x < 5$
A_4	$5 \leq x < 8$

Depth of Cut (B)

B_1	$0.1 \leq x < 2.0$
B_2	$2 \leq x < 6$
B_3	$6 \leq x < 60$

Hardness Ratio (C)

C_1	$0.2 \leq x < 0.5$
C_2	$0.5 \leq x < 0.7$
C_3	$0.7 \leq x < 0.9$
C_4	$0.9 \leq x < 1.2$

Velocity (D)

D_1	$0 \leq x < 10$
D_2	$10 \leq x < 20$
D_3	$20 \leq x < 33.3$
D_4	$33.3 \leq x < 70$

Replications

- *Replication 1 - Jim Walter Resources, No. 3 Mine
- *Replication 2 - Emway Resources, Emerald No. 1 Mine
- *Replication 3 - Kaiser Coal, Sunnyside Mine
- *Replication 4 - North River Energy Corporation

The preliminary analysis of variance of the data in Table C2 (Appendix I) is given in Table 20.

The ANOVA table (Table 20) indicates that there are no significant three- or four-factor interactions while all of the two-factor interactions involving analog signal are found to be significant at a 0.5-percent level of confidence.

AB Interaction

$$F \text{ calc.} = 4.477$$

$$\text{Freq} (0.005, 6, 573) = 3.136$$

$$F \text{ calc.} > \text{Freq.}$$

AC Interaction

$$F \text{ calc.} = 6.537$$

$$\text{Freq.} (0.005, 9, 573) = 2.657$$

$$F \text{ calc.} > \text{Freq.}$$

AD Interaction

$$F \text{ calc.} = 19.72$$

$$\text{Freq.} (0.005, 9, 573) = 2.657$$

$$F \text{ calc.} > \text{Freq}$$

Two-Factor Interaction: Analog Signal (A) X Depth of Cut (B)

Table 21a is a summary table for the treatment conditions involved in this significant interaction. The values in Table 21a were normalized and used to plot the profiles for each of the levels of analog signal (Figure 30a). The profiles indicate that the depth of cut had a different effect on each of the levels of analog signal. The significance of these differences in effect are shown in Table 23a. From Table 23a, we find that A_2 is significant at a 0.5-percent level of confidence. From Table 21a, A_2 is found to occur most frequently with B_2 and B_3 , while levels A_1 , A_3 , and A_4 cannot be associated with any level of depth of cut. From these observations, it appears that depth of cut has no overall effect on the output of the CID for rock cutting.

Two-Factor Interaction: Analog Signal (A) X Hardness Ratio (C)

The summary of the data in Table C2 for this interaction is shown in Table 21b. The profiles for each of the levels of analog signal are shown in Figure 30b. These geometric representations indicate that the levels of hardness ratio have an effect on each of the levels of analog signal. The significance of these effects are summarized in Table 23b. Analog signal levels A_1 and A_3 are found to be significant at a 0.5-percent level of confidence. From Table 21b and Figure 30b, A_1 is found to be correlated with C_3 , and A_3 is found to be associated almost equally with C_1 , C_2 , and C_3 .

From these observations, it can be concluded that the hardness ratio does influence the output of the CID. The magnitude of the CID signal was found to increase as the rock hardness increased. This is indicated by the slopes of profiles A_1 , A_2 , and A_3 .

Two-Factor Interaction: Analog Signal (A) X Velocity (D)

The results for this two-factor interaction are summarized in Table 21c. The geometric representations of the normalized data in Table 21c is shown in Figure 30c. These profiles of each of the levels of analog signal differ markedly from each other. The results of the test on the hypothesis that there was no difference between levels of velocity for each of the levels of analog signal are summarized in Table 23c. The data for levels A_1 , A_2 , and A_3 clearly indicate a significant difference between levels of velocity (D). Analog signal level A_1 tests to be significant at the 0.5-percent level of confidence and from Figure 30c we can see that it is strongly associated with D_2 . Level A_2 also tests to be significant at a 0.5-percent level of confidence and is correlated with D_3 . Level A_3 is significant at a 2.5-percent level of confidence and appears to be equally associated with levels D_3 and D_4 .

As we found in the previous factorial experiment, the magnitude of the analog signal increased as the magnitude of the velocity increased. At the higher velocities the cutting bits have a greater force of impact on the rock strata.

TABLE 20. Analysis of Variance Table (ANOVA) for the Percentage of Cutting Signals When Cutting Rock

E. STATISTICAL ANALYSIS

SOURCE OF VARIATION	D O F	SUM OF SQUARES	MEAN SQUARE	F FACTOR
REPLICATES	3.000	7604.	2535.	5.895
MAIN EFFECTS				
FACTOR 1.	3.000	.2171E+05	7235.	16.83
2.	2.000	-7044.	-3522.	-8.192
3.	3.000	.1427E+05	4757.	11.06
4.	3.000	-.5333E+05	-.1778E+05	-41.35
TWO FACTOR INTERACTION				
1,2.	6.000	.1155E+05	1925.	4.477
1,3.	9.000	.2530E+05	2811.	6.537
1,4.	9.000	.7630E+05	8478.	19.72
2,3.	6.000	9753.	1625.	3.780
2,4.	6.000	.7673E+05	.1279E+05	29.74
3,4.	9.000	.6948E+05	7720.	17.95
THREE FACTOR INTERACTION				
1,2,3.	18.00	2634.	146.3	.3403
1,2,4.	18.00	-.7134E+05	-3964.	-9.218
1,3,4.	27.00	-.5115E+05	-1894.	-4.406
2,3,4.	18.00	-.7069E+05	-3927.	-9.134
FOUR FACTOR INTERACTION				
1,2,3,4.	54.00	-.4656E+05	-862.3	-2.005
ERROR	573.0	.2464E+06	430.0	1.000

TABLE 21 a
 Summary Table for the Two Factor Interaction Involving
 Analog Signal and Depth of Cut for the Rock Cutting Data Points

	A1	A2	A3	A4
B1	823.61	278.4	498.09	0
B2	1139.35	897.06	463.57	0
B3	878.63	799.97	597.32	24.11

TABLE 21b
 Summary Table for the Two Factor Interaction Involving
 Analog Signal and Hardness Ratio for the Rock Cutting Data Points

	A1	A2	A3	A4
C1	75.4	567.27	557.44	0
C2	833.39	631.82	510.69	24.11
C3	1696.81	512.33	490.85	0
C4	235.99	264.01	0	0

TABLE 21c
 Summary Table for the Two Factor Interaction Involving
 Analog Signal and Velocity for the Rock Cutting Data Points

	A1	A2	A3	A4
D1	100	220	80	0
D2	1213.93	388.96	397.12	0
D3	830.75	897.9	552.11	19.35
D4	696.91	568.57	529.75	4.76

ANAL. SIG. PRO. FOR LEV. OF D.O.C., ROCK CUTTING

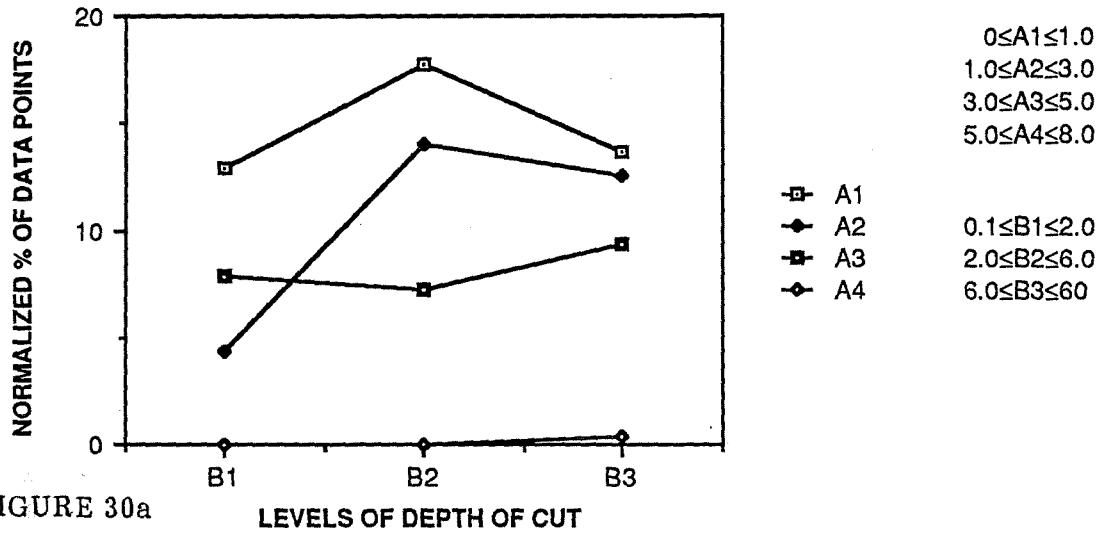

FIGURE 30a

ANAL. SIG. PRO. FOR LEV. OF H.R., ROCK CUTTING

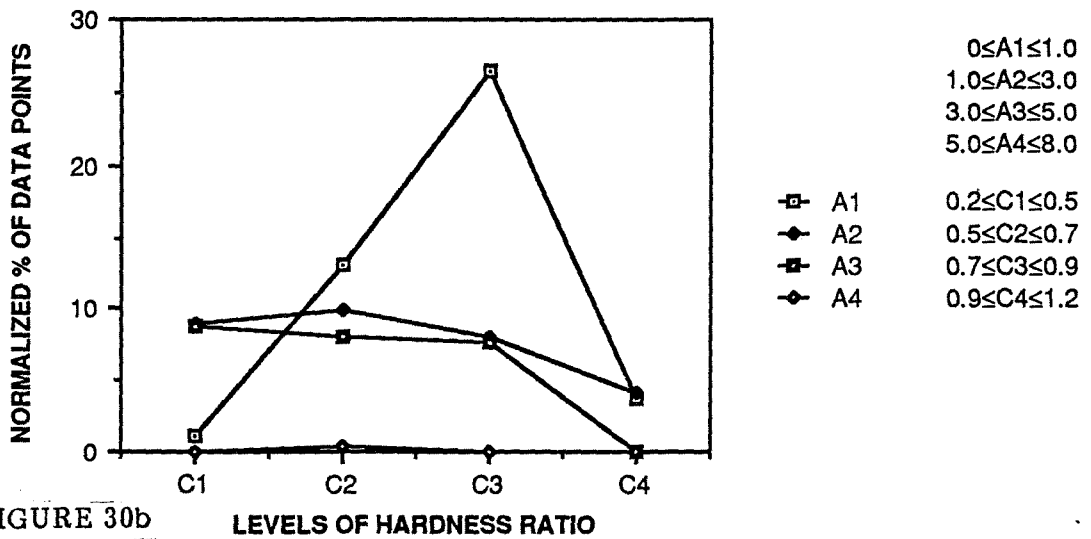

FIGURE 30b

FIGURES 30a and 30b. Profiles of Each of the Levels of Analog Signal for the Levels of a) Depth of Cut and b) Hardness Ratio for the Percentage of Cutting Signals When Cutting Rock

TABLE 22

Freq. for the Factors Involved in the Rock Cutting Factorial Experiment

D.F.S.V./D.F.M.S.E.	LEVELS		OF	SIGNIFICANCE		
	10%	5%	2.50%	1%	0.50%	
2/573	2.31	3.009	3.717	4.647	5.356	
3/573	2.1	2.619	3.139	3.817	4.327	
6/573	1.79	2.119	2.429	2.837	3.136	
9/573	1.64	1.899	2.139	2.439	2.657	
18/573	1.464	1.619	1.779	1.967	2.107	
27/573	1.384	1.509	1.625	1.772	1.881	
54/573	1.304	1.362	1.442	1.539	1.612	

D.F.S.V. = Degree's of Freedom for the Source of Variation

D.F.M.S.E. = Degree's of Freedom for the Mean Square Error

TABLE 23a

Summary of the Simple Effects of Depth of Cut (B) on Analog Signal(A)

S.E. CALC.	LEVELS		CF	ANALOG		SIGNAL
	A1	A2	A3	A4		
SSBAi	889.03	3459.39	150.66	6.06		
MSBAi	444.52	1729.69	75.33	3.03		
Fcalc.	1.0338	4.0225	0.1752	0.007		
LEVEL OF SIG.	NOT SIG.	0.50%	NOT SIG.	NOT SIG.		

S.E. CALC. = Simple Effects Calculations

SSBAi = Sum of Squares of the levels of Factor B for each level of Factor A

MSBAi = Mean Square for the levels of Factor B for each level of Factor A

Fcalc. = Calculated F factor

TABLE 23b

Summary of the Simple Effects of Hardness Ratio (C) on Analog Signal (A)

S.E. CALC.	LEVELS	CF	ANALOG		SIGNAL
	A1	A2	A3	A4	
SSCAi	33675.4	1616.54	4268.18		9.08
MSCAi	11225.15	538.85	1422.73		3.03
Fcalc.	26.105	1.2531	3.3087		0.007
LEVEL OF SIG.	0.50%	NOT SIG.	0.50%		NOT SIG.

S.E. CALC. = Simple Effects Calculations

SSCAi = Sum of Squares for the level of Factor C for each level of Factor A

MSCAi = Mean Square for the levels of Factor C for each level of Factor A

Fcalc. = Calculated F factor

TABLE 23c

Summary of the Simple Effects of Velocity (D) on Analog Signal (A)

S.E. CALC.	LEVELS	CF	ANALOG		SIGNAL
	A1	A2	A3	A4	
SSDAi	13349.93	6658.44	2957.5		5.24
MSDAi	4449.98	2219.48	985.83		1.75
Fcalc.	10.3488	5.1616	2.2926		0.41
LEVEL OF SIG.	0.50%	0.50%	2.50%		NOT SIG.

S.E. CALC. = Simple Effects Calculations

SSDAi = Sum of Squares for the levels of Factor D for each level of Factor A

MSDAi = Mean Square for the levels of Factor D for each level of Factor A

F calc. = Calculated F factor

ANAL. SIG. PRO. FOR LEV. OF VEL., ROCK CUTTING

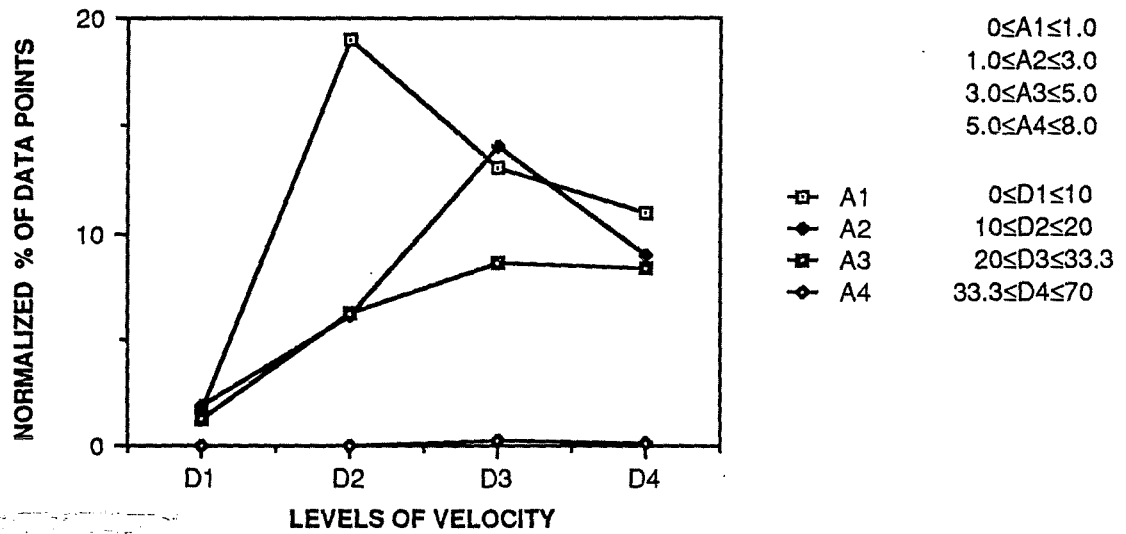

FIGURE 30c. Profiles of Each of the Levels of Analog Signal for the Levels of Velocity for the Percentage of Cutting Signals When Cutting Rock

Percentage of Correct Rock Cutting Signals (All Data Points)

Table 24 summarizes the association between the occurrence of each of the levels of analog signal (A) for each of the levels of primary factors (i.e., depth of cut into rock (B), coal/rock hardness ratio (C), and shearer velocity (D)) involved in rock cutting. This table consists of all the primary data collected for rock cutting during the data acquisition phase of this project.

A range of CID analog signal output was assigned for rock cutting, and the percentage of correct rock cutting signals was determined from the values shown in Table 24. The percentage of rock cutting signals was found to be approximately 1-percent correct, assuming that an analog signal voltage of greater than or equal to 5 volts is assigned to rock cutting (Figure 31a). When an analog signal output of greater than or equal to 3 volts is assigned to rock cutting, it is found that approximately 23 percent of the rock cutting signals are correct (Figure 31b). Assigning an analog signal of greater than or equal to 1 volt to rock cutting results in approximately 48 percent of the cutting signals being correct (Figure 31c).

A conclusion on the effectiveness of the CID for rock cutting cannot be made until the distribution of analog signals for coal cutting is investigated.

TABLE 24. Percentage of Occurrence of Analog Signal for Each Primary Factor, Rock Cutting (All Data Points)

ROCK CUTTING, ALL DATA								
TOTAL NUMBER OF DATA POINTS=1189								
PERCENTAGE OF OCCURRENCE								
ANALOG SIGNAL VS. DEPTH OF CUT								
ANALOG SIGNAL=A								
A1: 0<X<1.0								
A2: 1.0<X<3.0								
A3: 3.0<X<5.0								
A4: 5.0<X<8.0								
		ANALOG SIGNAL LEVEL						
		DEPTH OF CUT	A1	A2	A3	A4	TOTAL	
B1: 0.1<X<2.0		B1	51 (4.29)	38 (3.20)	54 (4.54)	0	143 (12.03)	
B2: 2.0<X<6.0		B2	340 (28.60)	152 (12.78)	93 (7.82)	0	585 (49.20)	
B3: 6.0<X<60		B3	230 (19.34)	106 (8.91)	117 (9.84)	8 (0.68)	461 (38.77)	
		TOTAL	621 (52.23)	296 (24.89)	264 (22.20)	8 (0.68)	1189 (100)	
ANALOG SIGNAL VS. HARDNESS RATIO								
HARDNESS RATIO=C								
ANALOG SIGNAL LEVEL								
		HARDNESS RATIO	A1	A2	A3	A4	TOTAL	
C1: 0.2<X<0.5		C1	4 (0.34)	27 (2.27)	37 (3.11)	0	68 (5.72)	
C2: 0.5<X<0.7		C2	120 (10.09)	155 (13.04)	125 (10.51)	8 (0.68)	408 (34.32)	
C3: 0.7<X<0.9		C3	456 (38.35)	102 (8.58)	102 (8.58)	0	660 (55.51)	
C4: 0.9<X<1.2		C4	41 (3.45)	12 (1.00)	0	0	53 (4.45)	
		TOTAL	621 (52.23)	296 (24.89)	264 (22.20)	8 (0.68)	1189 (100)	
ANALOG SIGNAL VS. VELOCITY								
ANALOG SIGNAL LEVEL								
		VELOCITY	A1	A2	A3	A4	TOTAL	
D1: 0<X<10		D1	5 (0.42)	2 (0.17)	4 (0.34)	0	11 (0.93)	
D2: 10<X<20		D2	112 (9.42)	32 (2.69)	62 (5.21)	0	206 (17.32)	
D3: 20<X<33.3		D3	372 (31.29)	194 (16.32)	142 (11.94)	6 (0.51)	714 (60.06)	
D4: 33.3<X<70		D4	132 (11.10)	68 (5.71)	56 (4.71)	2 (0.17)	258 (21.69)	
		TOTAL	621 (52.23)	296 (24.89)	264 (22.20)	8 (0.68)	1189 (100)	

% OF ROCK CUTTING SIGNALS ALL DATA (A.S.≥5)

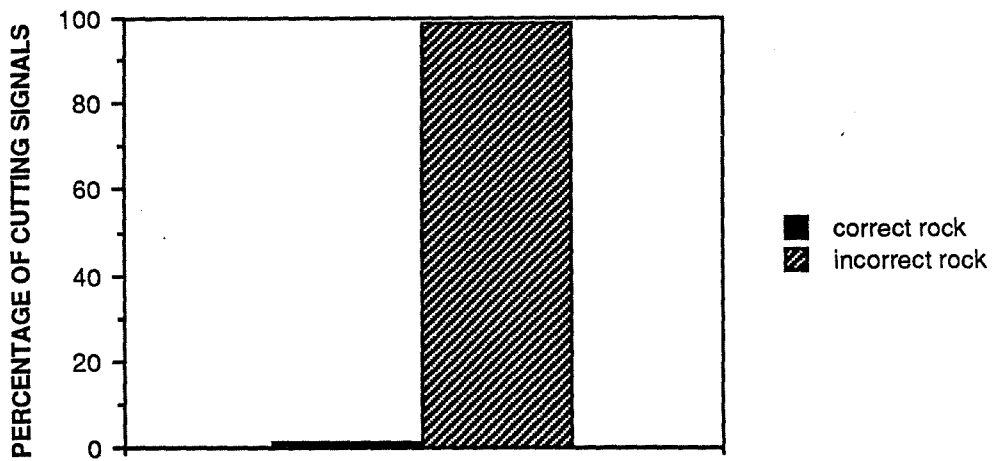

FIGURE 31a. Percentage of Correct and Incorrect Rock Cutting Signals (Analog Signal ≥ 5), All Data Points

% OF ROCK CUTTING SIGNALS ALL DATA (A.S.≥3)

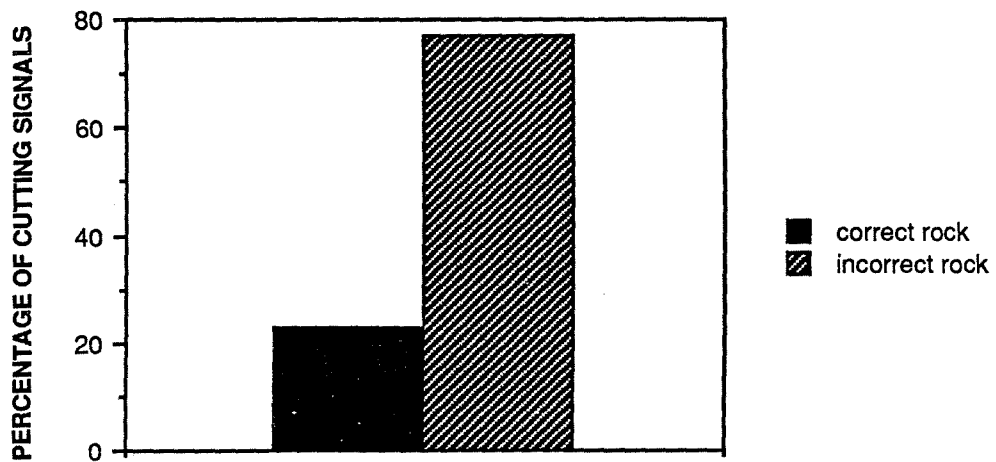

FIGURE 31b. Percentage of Correct and Incorrect Rock Cutting Signals (Analog Signal ≥ 3), All Data Points

% OF ROCK CUTTING SIGNALS ALL DATA (A.S.≥1)

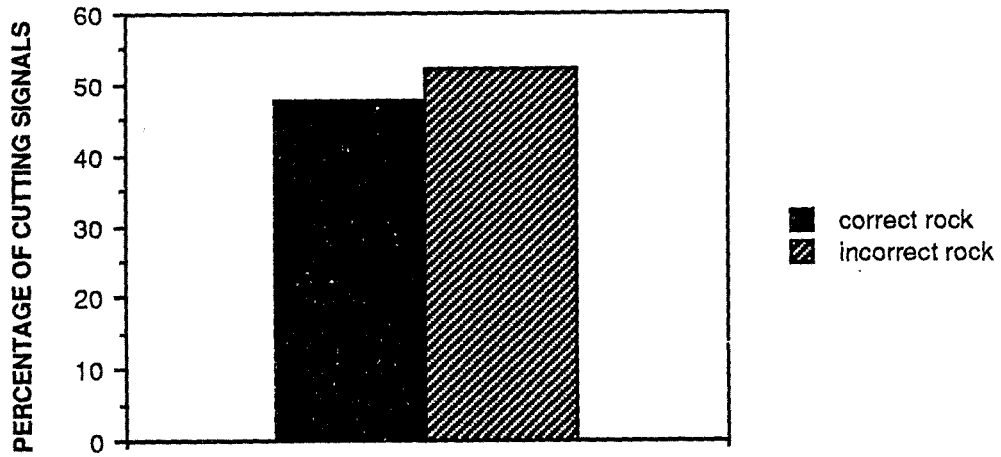

FIGURE 31c. Percentage of Correct and Incorrect Rock Cutting Signals (Analog Signal ≥ 1), All Data Points

% OF ROCK CUTTING SIGNALS ALL DATA (A.S.≥0)

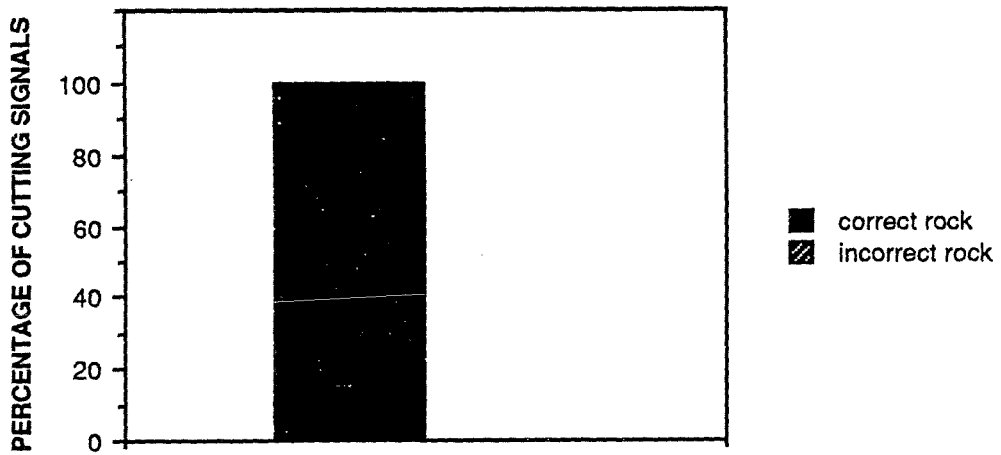

FIGURE 31d. Percentage of Correct and Incorrect Rock Cutting Signals (Analog Signal ≥ 0), All Data Points

PERCENTAGE OF CUTTING SIGNALS WHEN CUTTING COAL

The results of this factorial experiment were investigated to determine the effect that hardness ratio and velocity had on the analog signal for all data pertaining to coal cutting. The experiment was replicated four times, and each replicate represents the data collected at one of the participating mines. The variable ranges assigned to the four factors chosen for this experiment are:

Analog Signal (A)

A_1	$0 \leq x < 1$
A_2	$1 \leq x < 3$
A_3	$3 \leq x < 5$
A_4	$5 \leq x < 8$

Depth of Cut (B)

B_1	$0 \leq x < 0.1$
-------	------------------

Hardness Ratio (C)

C_1	$0.2 \leq x < 0.5$
C_2	$0.5 \leq x < 0.7$
C_3	$0.7 \leq x < 0.9$
C_4	$0.9 \leq x < 1.2$

Velocity (D)

D_1	$0 \leq x < 10$
D_2	$10 \leq x < 20$
D_3	$20 \leq x < 33.3$
D_4	$33.3 \leq x < 70$

Replications

- *Replication 1 - Jim Walter Resources, No. 3 Mine
- *Replication 2 - Emway Resources, Emerald No. 1 Mine
- *Replication 3 - Kaiser Coal, Sunnyside Mine
- *Replication 4 - North River Energy Corporation

Table 25 is the ANOVA table for the data of C3 (Appendix J). This ANOVA table indicates significance for the two-factor interactions involving analog signal (A) and hardness ratio (C) and for analog signal (A) and velocity (D). Both of these interactions are found to be significant at the 0.5-percent level of confidence.

AC Interaction

F calc. = 3.249
Freq. (0.005, 9, 189) = 2.739
F calc. > Freq.

AD Interaction

F calc. = 7.554
Freq. (0.005, 9, 189) = 2.739
F calc. > Freq.

The three- and four-factor interactions do not test to be significant.

Two-Factor Interaction: Analog Signal (A) X Hardness Ratio (C)

Table 26a is a summary table of the data for each treatment condition involving analog signal and hardness ratio. The data in Table 26a was normalized and used to develop the profiles for each of the levels of analog signal (Figure 32a). The profiles show a difference in the effect of the level of hardness ratio (C) for each of the levels of analog signal (A). The results of the investigation to determine the significance of these differences in simple effects are shown in Table 28a.

Analog signal level A_1 tests to be significant at a 0.5-percent level of confidence and is found to be most strongly associated with hardness ratio level C_3 . Analog signal level A_2 also is found to be significant at a 0.5-percent level of confidence and is found to occur most frequently with hardness ratio level C_1 . These results seem to contradict the effect of hardness on the level of signal output. At hardness ratio level C_3 , we find a much harder coal than at hardness ratio C_1 . This discrepancy may be explained by the condition of the coal face at the time of testing. The face abutment pressure was much greater at the Emway Resources Emerald No. 1 Mine and Kaiser Coal's Sunnyside Mine (hardness ratio C_3) than at the Jim Walter (Resources No. 3 Mine and the North River Energy Corporation Mine (hardness ratio C_1)). The high abutment pressure caused the coal along the face to fracture and soften, thus making it easier to mine.

Two-Factor Interaction: Analog Signal (A) X Velocity (D)

Table 26b is a summary of the data in Table C3 for this two-factor interaction. The data in Table 26b was normalized and used to plot the profiles for each of the levels of analog signal (Figure 32b). The results of the calculations performed to determine the significance of the differences in the levels of velocity for each of the levels of analog signal are summarized in Table 28b. The null hypothesis of no difference in levels of velocity for each level of analog signal is rejected for analog signal levels A_1 and A_2 . A_1 is found to be significant at a 10-percent level of confidence and is found to be correlated with D_3 . Level A_2 tests to be significant at a 1-percent level of confidence and is found to occur most frequently with D_4 .

As in the prior factorial experiments, we find that as the magnitude of velocity increased the magnitude of the analog signal increased. As implied earlier, this may be caused by the greater force of impact that the cutting bits impart to the cutting surface at higher velocities.

TABLE 25. Analysis of Variance Table (ANOVA) for the Percentage of Cutting Signals When Cutting Coal

E. STATISTICAL ANALYSIS

SOURCE OF VARIATION	D O F	SUM OF SQUARES	MEAN SQUARE	F FACTOR
REPLICATES	3.000	5312.	1771.	2.384
MAIN EFFECTS				
FACTOR 1.	3.000	.2894E+05	9647.	12.99
2.	.0000	-.3809E+05	.0000	.0000
3.	3.000	5312.	1771.	2.384
4.	3.000	-.4000E+05	-.1333E+05	-17.95
TWO FACTOR INTERACTION				
1, 2.	.0000	.3809E+05	.0000	.0000
1, 3.	9.000	.2172E+05	2413.	3.249
1, 4.	9.000	.5050E+05	5611.	7.554
2, 3.	.0000	.3809E+05	.0000	.0000
2, 4.	.0000	.8340E+05	.0000	.0000
3, 4.	9.000	.4844E+05	5382.	7.245
THREE FACTOR INTERACTION				
1, 2, 3.	.0000	-.3809E+05	.0000	.0000
1, 2, 4.	.0000	-.8340E+05	.0000	.0000
1, 3, 4.	27.00	-.2897E+05	-1073.	-1.444
2, 3, 4.	.0000	-.8340E+05	.0000	.0000
FOUR FACTOR INTERACTION				
1, 2, 3, 4.	.0000	2771.	.0000	.0000
ERROR	189.0	.1404E+06	742.8	1.000

TABLE 26 a
 Summary Table for the Two Factor Interaction Involving
 Analog Signal and Hardness Ratio for Coal Cutting Data Points

	A1	A2	A3	A4
C1	27.79	662.12	10.1	0
C2	479.11	340.04	80.83	0
C3	718.42	319.66	161.93	0
C4	300	100	0	0

TABLE 26 b
 Summary Table for the Two Factor Interaction Involving
 Analog Signal and Velocity for the Coal Cutting Data Points

	A1	A2	A3	A4
D1	200	100	0	0
D2	439.89	386.62	73.47	0
D3	537.98	422.11	39.92	0
D4	347.45	513.09	139.47	0

ANAL. SIG. PRO. FOR LEV. OF H.R., COAL CUTTING

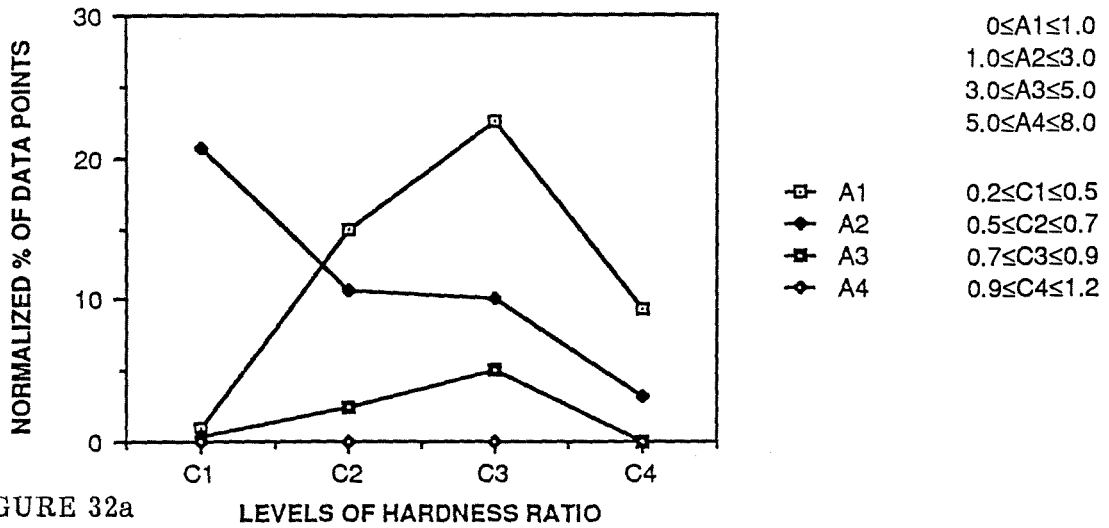

FIGURE 32a

ANAL. SIG. PRO. FOR LEV. OF VEL., COAL CUTTING

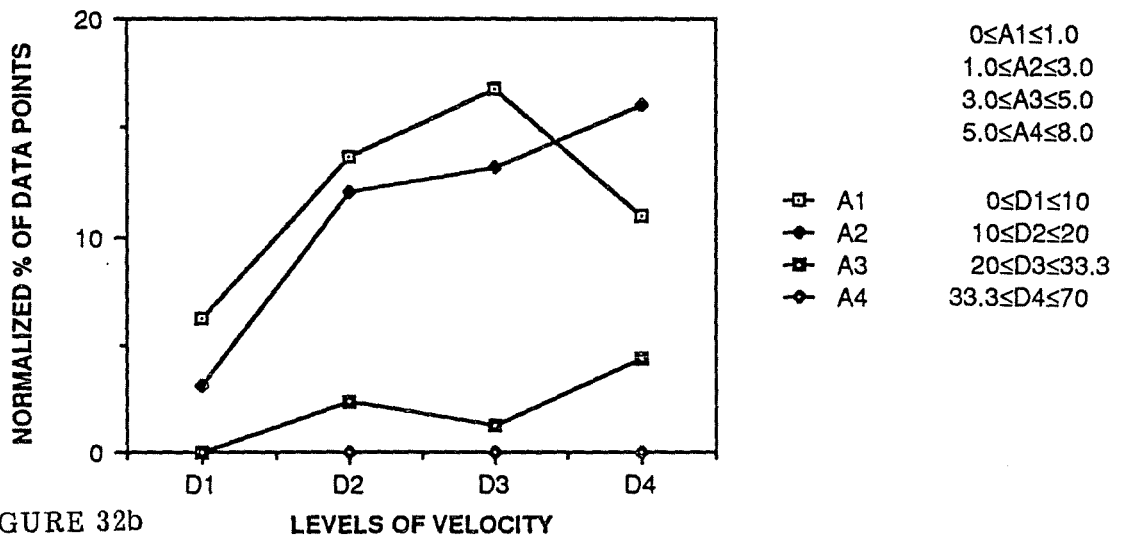

FIGURE 32b

FIGURES 32a and 32b. Profiles of Each of the Levels of Analog Signal for the Levels of a) Hardness Ratio and b) Velocity for the Percentage Cutting Signals When Cutting Coal

TABLE 27

Freq. for the Factors Involved in the Coal Cutting Factorial Experiment

D.F.S.V./D.F.M.S.E.	LEVELS		OF	SIGNIFICANCE		
	10%	5%	2.50%	1%	0.50%	
3/189	2.113	2.652	3.184	3.889	4.414	
9/189	1.664	1.932	2.184	2.507	2.739	
27/189	1.408	1.544	1.674	1.838	1.964	

D.F.S.V. =Degrees of Freedom for the Source of Variation
D.F.M.S.E. =Degrees of Freedom for the Mean Square Error

TABLE 28 a

Summary of the Simple Effects of Hardness Ratio (C) on Analog Signal (A)

S.E. CALC.	LEVELS		OF	ANALOG		SIGNAL
	A1	A2	A3	A4		
SSCAi	15924.73	10051.22	1054.52	0		
MSCAi	5308.24	3350.41	651.51	0		
Fcalc.	7.1463	4.5105	0.4732	0		
LEVEL OF SIG.	0.50%	0.50%	NOT SIG.	NOT SIG.		

S.E. CALC. = Simple Effects Calculations
SSCAi = Sum of Squares for the levels of factor C for each level of Factor A
MSCAi = Mean Square for the levels of Factor C for each level of Factor A
Fcalc. = Calculated F factor

TABLE 28 b

Summary of the Simple Effects of Velocity (D) on Analog Signal (A)

S.E. CALC.	LEVELS		OF	ANALOG		SIGNAL
	A1	A2	A3	A4		
SSDAi	3874.81	5970.01	653.67	0		
MSDAi	1291.6	1990	217.89	0		
Fcalc.	1.7388	2.6791	0.2933	0		
LEVEL OF SIG.	10%	1%	NOT SIG.	NOT SIG.		

S.E. CALC. = Simple Effects Calculations
SSDAi = Sum of Squares for the levels of Factor D for each level of Factor D
MSDAi = Mean Square for the levels of Factor D for the each level of Factor A
Fcalc. = Calculated F factor

Percentage of Correct Coal Cutting Signals (All Data Points)

Table 29 is a summary correlating the number of occurrences of each of the levels of analog signal (A) for each of the level of the primary factors (i.e., depth of cut into rock (B), coal/rock hardness ratio (C), and shearer velocity (D)) involved in coal cutting. This table consists of all the primary data collected for coal cutting during the data acquisition phase of this project.

The question as to how effective the CID was in determining when coal was being cut was answered by assigning a range of analog signal data to coal cutting and then calculating the percentage of correct coal cutting signals. These percentages were calculated from values shown in Table 29.

Selecting an analog signal of less than 1 volt for coal cutting results in the CID being effective in approximately 51 percent of the instances where coal was being cut (Figure 33a). Choosing an analog signal of less than 3 volts for coal cutting results in the CID being effective in approximately 94 percent of the instances where coal was being cut (Figure 33b), and assigning an analog signal of less than 5 volts to coal cutting reveals that the CID was 100-percent effective in determining when coal was being cut (Figure 33c).

A comparison of the analysis of the percentage of correct coal cutting signals and correct rock cutting signals was required to determine the effectiveness of the CID for each of these cutting conditions. It was necessary to assign a level of analog signal for one of the cutting conditions and determine CID effectiveness. Based on this, the effectiveness of the remaining cutting conditions could be determined.

An analog signal of less than 1 volt was chosen for coal cutting. This established the CID as being 51-percent effective in determining when coal was being mined and 48-percent effective in determining when rock was being cut. When an analog signal of greater than 1 volt is chosen for coal cutting, the percentage of correct coal cutting signals increased while the percentage of correct rock cutting signals decreased.

TABLE 29. Percentage of Occurrence of Analog Signal for Each Primary Factor, Coal Cutting (All Data Points)

COAL CUTTING, ALL DATA							
TOTAL NUMBER OF DATA POINTS=1288							
PERCENTAGE OF OCCURRENCE							
ANALOG SIGNAL VS. DEPTH OF CUT							
ANALOG SIGNAL=A							
A1: 0<X<1.0							
A2: 1.0<X<3.0							
A3: 3.0<X<5.0							
A4: 5.0<X<8.0							
	DEPTH OF CUT	A1	A2	A3	A4	TOTAL	
	B1	663 (51.48)	545 (42.31)	80 (6.22)	0	1288	
	TOTAL	663 (51.48)	545 (42.31)	80 (6.22)	0	1288	
DEPTH OF CUT=B							
B1: 0<X<0.1							
ANALOG SIGNAL VS. HARDNESS RATIO							
HARDNESS RATIO=C							
C1: 0.2<X<0.5							
C2: 0.5<X<0.7							
C3: 0.7<X<0.9							
C4: 0.9<X<1.2							
	HARDNESS RATIO	A1	A2	A3	A4	TOTAL	
	C1	18 (1.40)	263 (20.42)	4 (0.31)	0	285 (22.13)	
	C2	287 (22.28)	269 (20.88)	45 (3.49)	0	601 (46.65)	
	C3	354 (27.48)	12 (0.93)	31 (2.42)	0	397 (30.83)	
	C4	4 (0.31)	1 (0.08)	0	0	5 (0.39)	
	TOTAL	663 (51.47)	545 (42.31)	80 (6.22)	0	1288 (100)	
VELOCITY=D							
D1: 0<X<10							
D2: 10<X<20							
D3: 20<X<33.3							
D4:33.3<X<70							
ANALOG SIGNAL VS. VELOCITY							
ANALOG SIGNAL LEVEL							
	VELOCITY	A1	A2	A3	A4	TOTAL	
	D1	3 (0.23)	1 (0.08)	0	0	4 (0.31)	
	D2	184 (14.29)	69 (5.36)	19 (1.48)	0	272 (21.13)	
	D3	427 (33.15)	374 (29.03)	42 (3.26)	0	843 (65.44)	
	D4	49 (3.80)	101 (7.84)	19 (1.48)	0	169 (13.12)	
	TOTAL	663 (51.47)	545 (42.31)	80 (6.22)	0	1288 (100)	

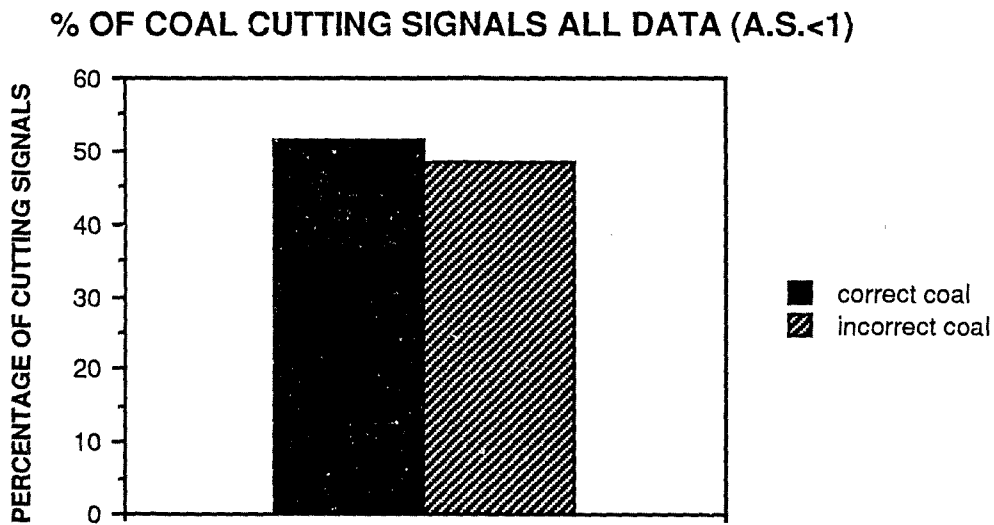

FIGURE 33a. Percentage of Correct and Incorrect Coal Cutting Signals (Analog Signal < 1), All Data Points

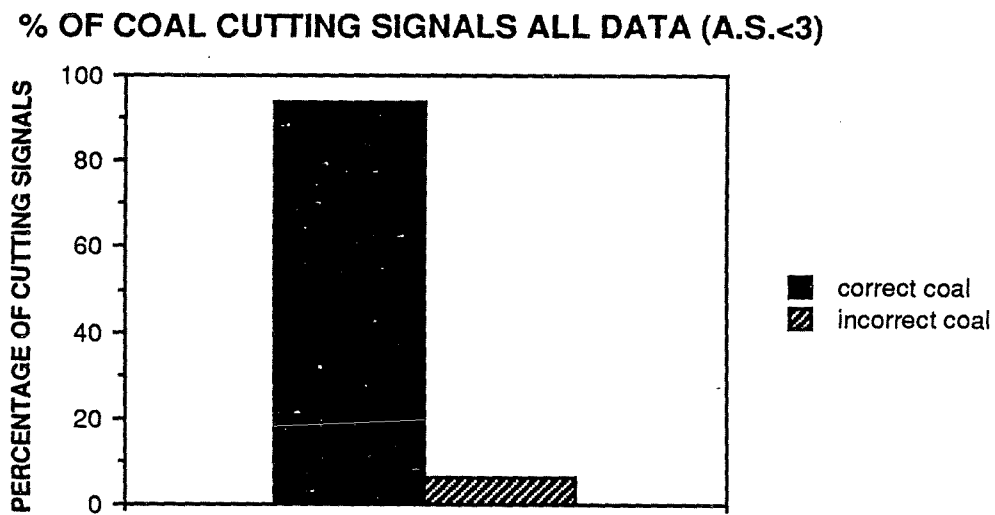

FIGURE 33b. Percentage of Correct and Incorrect Coal Cutting Signals (Analog Signal < 3), All Data Points

% OF COAL CUTTING SIGNALS ALL DATA (A.S.<5)

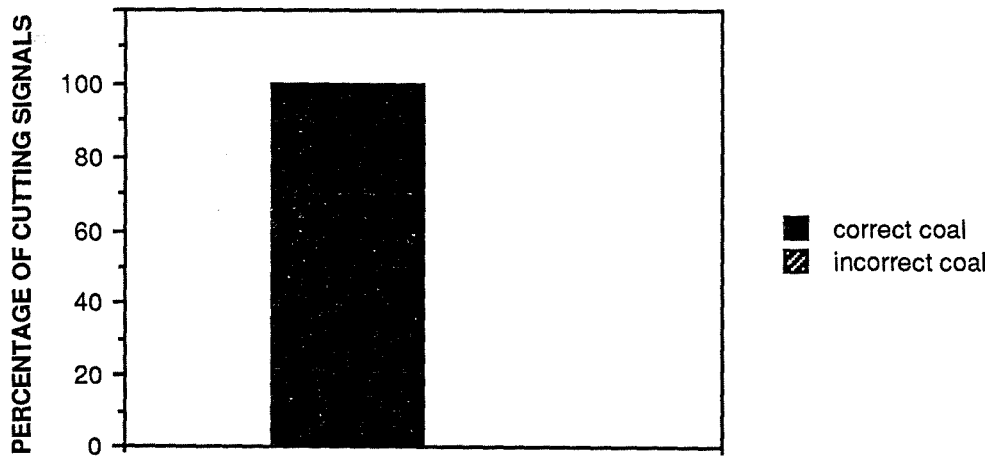

FIGURE 33c. Percentage of Correct and Incorrect Coal Cutting Signals (Analog Signal <5), All Data Points

VIII. CONCLUSIONS AND RECOMMENDATIONS

The results of the extensive field tests indicate that the shearer vibration data processed by GE's time domain signal processing algorithm cannot be used reliably to detect when the shearer cutting drum crossed the coal/rock interface. At best, the CID proved to be approximately 50-percent effective in determining when the coal/rock horizon had been traversed.

When considering the data from each respective minesite, the CID proved to be most effective at the North River Energy Corporation Mine. The effectiveness of the CID was sustained in over 50 percent of the instances when the coal/rock horizon had been crossed. The coal seam at the minesite was the least friable of all tested, and the predominant difference between the hardness of the coal and rock strata was the largest sampled.

The analysis of the data collected from the other participating mines revealed that there was no difference in the CID analog output for either cutting coal or rock. The coal seams at these minesites were very friable, and the difference between the coal and rock hardness readings taken were small.

The factorial analysis section of the report confirms that velocity does influence the CID analog output. Analysis of the tables and graphs for this interaction show that as the magnitude of the velocity increases, the magnitude of the analog signal also increased. This may be due to the cutting bits impacting a greater force of impact on the cutting surface at higher velocity. It appears that the depth of cut into rock and the hardness ratio had no effect on the analog signal output of the CID.

Based on the data obtained and the analysis performed in this investigation, it is recommended that the GE sensor not be considered as a coal interface detector for use on future automated extraction systems.

The recorded raw vibration data and documentation generated in the course of this effort provides the Bureau with a valuable data base for the assessment of other signal processing schemes.

APPENDIX A

DATA ACQUISITION SYSTEM

APPENDIX A. DATA ACQUISITION SYSTEM

A MSHA experimental permit will be obtained for the instrumentation system as block diagramed in Figure A1. The important operational characteristics of each element of the system are given below.

1. Coal interface detector (CID)⁵

The CID is intended to determine from the machine vibration signal when the coal rock interface has been crossed by the cutter drum.

The most consistent coal/rock discriminant in the time domain was found to be the amplitude of signal modulations which occur due to bit impacts. Modulation amplitude appears to be directly related to the hardness of the material being cut. This time domain discriminant is attractive since it was found to be largely independent of the exact design of the shearer cutting components, and hence would avoid the tuning problem inherent in the frequency domain technique.

The coal/rock discriminant must be extracted electronically from the complete wide-band accelerometer signal and compared with set point values; normalization is necessary to minimize effects of shearer operating parameters; and appropriate averaging must be used to reduce the incidence of false indications caused by instantaneous vibration fluctuations unrelated to the cutting process.

A Horizon Control Sensor based on the time domain technique has been designed and built. The block diagram for this Sensor is shown in Figure A2. First, an automatic gain control is used to normalize the accelerometer signal (based on the amplitudes of the signal peaks, averaged over 1 sec). The normalized signal is then sent through a band-pass filter with a relatively broad bandwidth (2 kHz to 4 kHz); this step focuses further analysis on that part of the spectrum closely associated with cutting vibrations from all tested shearers and hence improves the signal-to-noise ratio. A root-mean-square (RMS) converter with integral DC-level subtractor yields the fluctuating level of the filtered signal as a function of time, while subsequent demodulation gives the envelope of the RMS signal. Finally, rectification and peak detection (with 5 sec acquire and 8 sec decay time constants, for averaging and minimization of instantaneous anomalies in the accelerometer signal) lead to an analog voltage proportional to the level of the vibration modulations, i.e., the coal/rock discriminant. The analog voltage is then compared with two setpoints corresponding to the values expected when the bits just begin penetration into the two rock layers, one being harder and the other softer than the coal seam itself (if both floor and roof rocks are harder than the coal, one of these set points is redundant. If the analog voltage level is greater than the higher set point or less than the lower set point, the Sensor yields a "rock" indication by means of an electrical switch and a light.

⁵ Most of the CID operation description taken from Norman R. Kuchen, Robert V. Klint, and Bernard Darrel, "A Vibration Sensor for Horizon Control in Automated Longwall Mining," NTIS # FE/9015-1, October 1977, 71 pp.

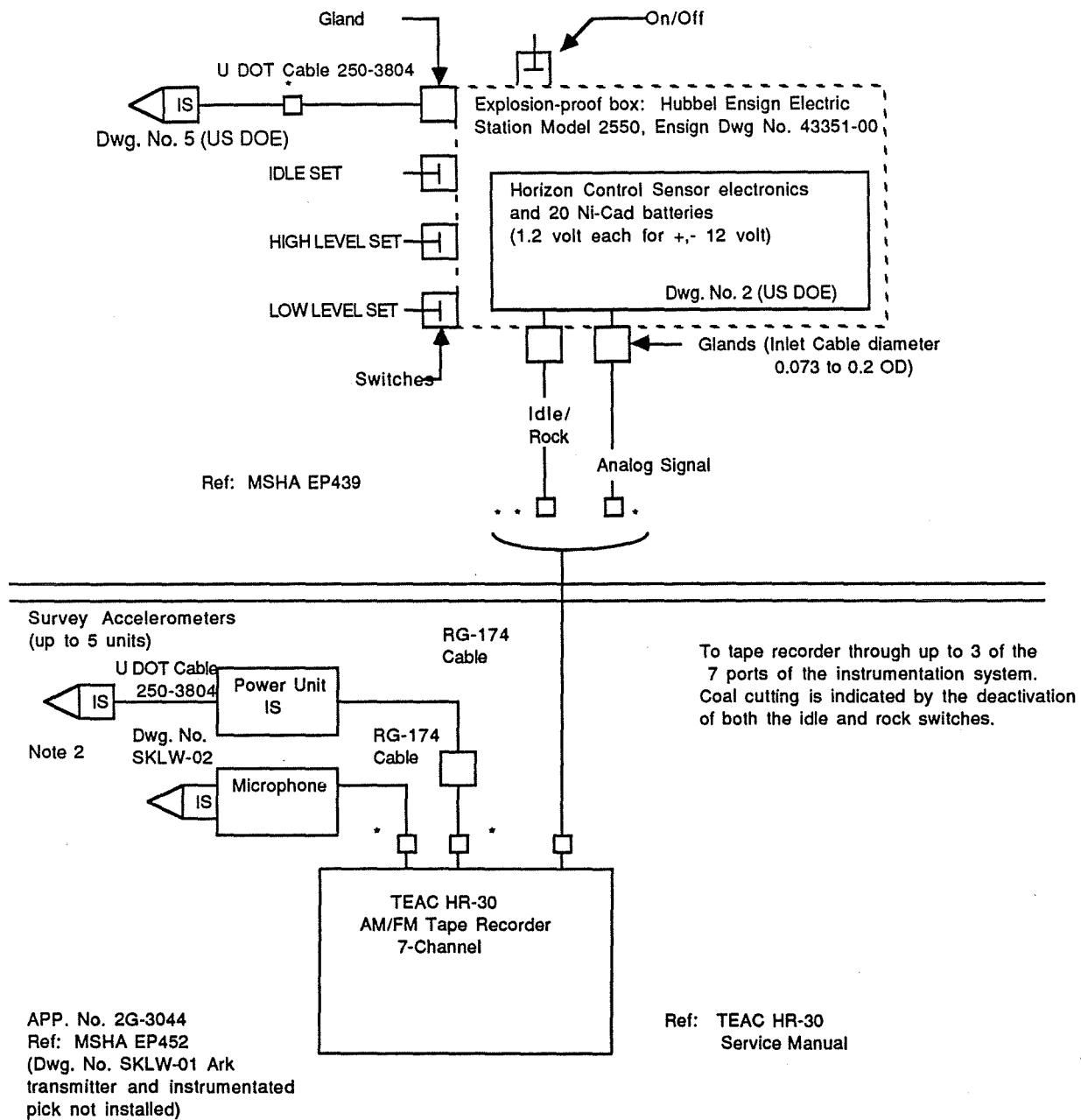

*BNC cable connectors

**Binch-Jones Multiple Connector. Pat. No. 2980881

Wyle Laboratories
Dwg. No. CIDS ALT
Date: 3/17/86

NOTES:

- (1) Unless otherwise indicated, all reference drawings are those of Wyle Laboratories. All referenced Dwgs. filed at MSHA-A&CC.
- (2) Total No. of survey accelerometers plus microphone does not exceed 6.
- (3) All cables must be installed in accordance with applicable requirements in 30 CFR Part 18.
- (4) No changes to these circuits may be made without approval of MSHA.

Figure A1. Coal Interface Detector Data Acquisition System Diagram

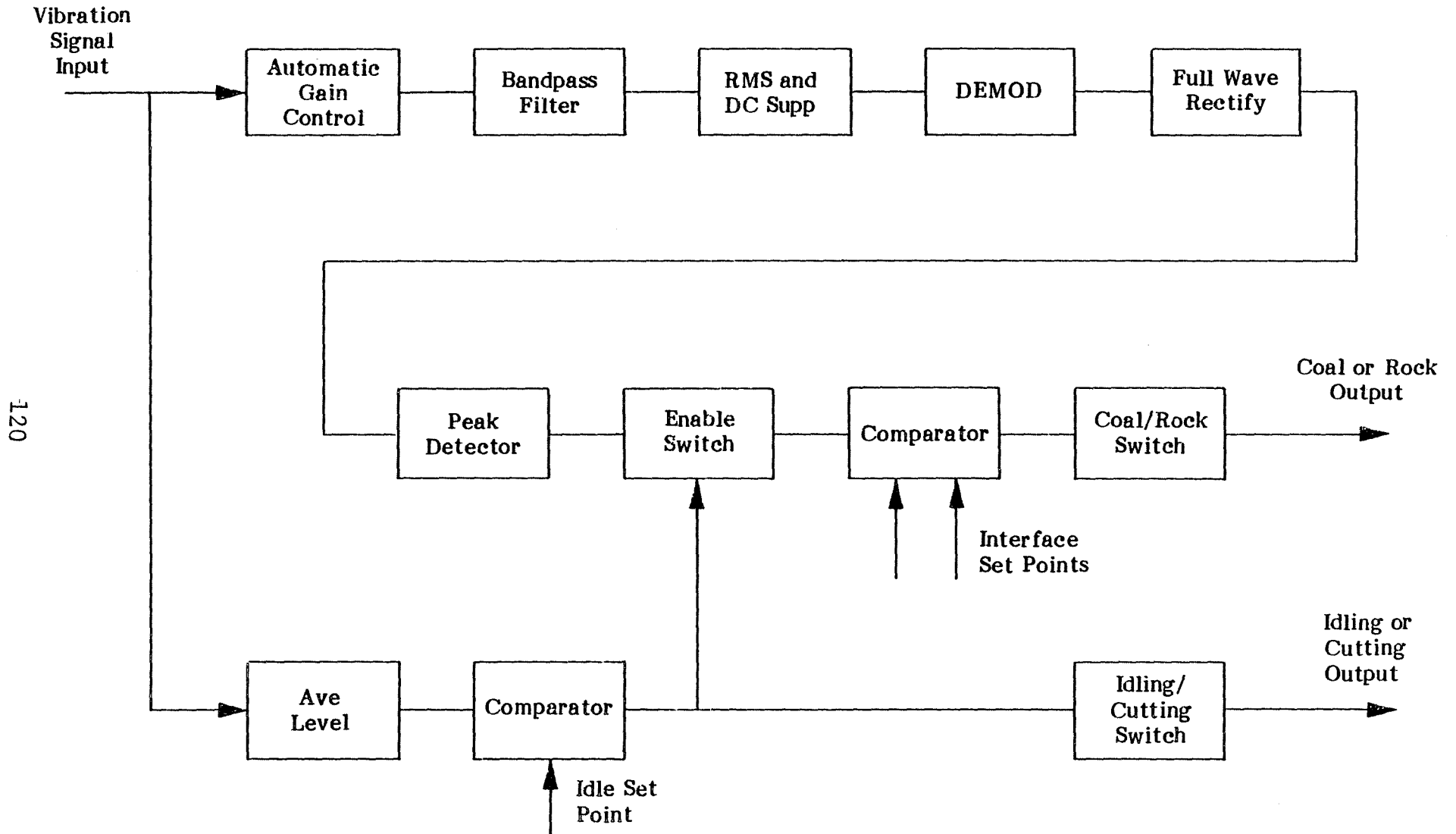

Figure A2. Block Diagram of Horizon Control Sensor - Time Domain Method

Because the automatic gain control normalizes the accelerometer signal regardless of its level, the circuitry described above would yield a "coal" or "rock" indication even if the shearer was not cutting and the shearer vibration consisted only of background noise. In order to eliminate false signals from this source, the accelerometer signal is also sent to an average level detector and comparator, where the signal level is compared with an "idling" set point, i.e., a value indicative of the vibration level when the shearer is idling and not cutting coal or rock. If the signal level exceeds the idling value, an enable switch is opened which allows the analog discriminant voltage to pass to the coal/rock comparator. Otherwise, this voltage is blocked, and electrical switch and visual outputs indicating "idling" are initiated.

The electronics for the time domain Horizon Control Sensor was placed on a single 6.5 by 6 inch printed circuit.

The circuit is powered by an internal battery pack consisting of 20 nickel-cadmium cells which produce a +12 volt output with a capacity of 1 amp-hr, sufficient to power the Sensor for about 8 hours of continuous operation. It is expected that the battery will be used as a power supply only during field evaluation of the Sensor, with external AC power being supplied if the Sensor is made part of complete automated longwall system.

Circuitry and battery pack were packaged inside a mine-permissible steel enclosure (Hubbel-Ensign Electric, Huntington, WV), shown in Figure 6.4. External sensor dimensions are 10 by 7 by 6.5 inches, and total weight is 38 lb. The cover plate contains the on-off switch, upper and lower discriminant level set point adjustments, the idle level set point adjustment, and a viewing window with 3 LED lights which indicate when the Sensor is on, when the shearer is idling, and when it is cutting into rock. Electrical inputs and outputs pass through 3 flame-proof glands in the enclosure side. Separate glands are provided for the accelerometer signal; the output of the analog discriminant signal; and the outputs of the "rock" and "idle" switches combined with a battery recharging connector.

The analog discriminant signal was recorded on FM channel 4 of the TEAC-HR30E tape recorder. The other switch indicators are simple voltage gates that will be varied by the data analysis software and hence need not be recorded.

2. CID Accelerometer

The accelerometer that feeds the vibration signal to the CID was located near the cutter drum on the shearer ranging arm. The accelerometer is a Bruel and Kjaer type 4344. It has the following characteristics:

- Weight - 2 grams
- Vibration sensitivity - 0.25 mV/ms⁻² and 0.25 pc/ms⁻²
- Useful frequency range ($\pm 10\%$) - 21 kHz
- Maximum peak vibration level - 3,000 g
- Maximum temperature - 482^oF

3. Survey Accelerometers

Several additional accelerometers were mounted on the shearing machine to provide additional data for future CID development work. The accelerometers are combined into two sets. Prior to September 28, 1986, a dual accelerometer was positioned very close to the CID accelerometer and was mounted in the X and Y direction with the CID accelerometer in the Z direction (triaxial accelerometer location #1). A triaxial accelerometer was placed on the shearing machine body near the CID (triaxial accelerometer location #2).

After September 28, 1986, one of the triaxial accelerometers (X direction, channel #1) from triaxial accelerometer location #2 was moved to a position in the Z direction of triaxial accelerometer location #1. This arrangement assured that an applicable source of data from the Z direction of triaxial accelerometer location #1 was recorded in the event of a CID malfunction.

The recorded vibration data from the survey accelerometers can later be analyzed to determine if the CID accelerometer could be placed in a much safer position on the shearing machine body instead of on the ranging arm.

Each survey accelerometer was a PCB model 308B. It has the following characteristics.

- Weight - 87 grams
- Vibration sensitivity - 100 mV/g
- Useful frequency range ($\pm 10\%$) - 8 kHz
- Maximum peak vibration - 500g
- Maximum temperature - 250^oF

The accelerometer has a built-in amplifier and comes with a battery operated power supply of +18 to 24 volts and 2 to 20 mA through a current regulating diode. The power supplies will be located in a rigid black carrying case for physical protection.

4. Tape Recorder

A TEAC Model HR-30 Type E 7-channel data cassette recorder was used underground to record the signals generated by the equipment described above. The recording format was mixed with direct record channels (1, 2, 3, 5 and 6) and FM wide band group I channels (4 and 7). This format allows 50 Hz-8 kHz bandwidth for the direct record channels and DC to 1.25 kHz bandwidth for the FM channels. TEAC CT-90 Type II cassette tapes were used with a recording time capability of approximately 45 minutes per cassette at 1-7/8 inches per second. This tape deck is specifically modified to meet MSHA permissibility standards for underground use. The record-only TEAC HR-30E tape format is compatible with the TEAC R-71 which was used for data reduction.

This tape deck is specifically modified to meet MSHA permissibility standards for underground use. The record-only TEAC HR-30E tape format is compatible with the TEAC R-71 which was used for data reduction.

APPENDIX B

OPERATING CHARACTERISTICS OF PARTICIPATING MINES

APPENDIX B
OPERATING CHARACTERISTICS OF EACH PARTICIPATING LONGWALL MINE

Mine	Jim Walter Resources No. 3 Mine	North River Energy Corporation	Emway Resources Emerald No. 1 Mine	Kaiser Coal Sunnyside Mine
Location	Adger, Alabama	Berry, Alabama	Waynesburg, PA	Sunnyside, Utah
Primary Contact	T. Burrage	P. Bradford	K. Seiber	R. Hughes
Shearer Type	A.M. 500	Eickhoff I50-2L	JOY 1LS	Misui Mike
Coal Seam	Blue Creek	Pratt	Pittsburgh	Lower Sunnyside
Shield Type and Width	Gullick Dobson 5' C to C	Heimscheidt 5' C to C	Dowty 5' C to C	Westfaliz 5' C to C
Operating Seam Height	78"	55"	72"	78"
Width of Longwall Face	600'	600'	615'	500'
Original Length of Panel	5000'	4500'	4000'	5700'
Length of Panel Last Visit	11/23/86 1500'	11/30/86 2535'	11/17/86 3000'	12/18/86 4800'
Drum Diameter	60"	53"	57"	72"
Bit Spacing	1" spacing	1" single pick per line	2 1/2" (varies)	?
Bit Type	Radial	Conical	Forward Attach AMT 4" Gauge	Shank
Number of Visits Made	3 visits 1 successful visit	3 visits	1 visit Successful	1 visit Successful

APPENDIX C

SCHMIDT TEST HAMMER OPERATING INSTRUCTIONS

Operating Instructions

Concrete Test Hammer

Type N

128



I. General Information

There are different types of test hammers:

Type N (Impact energy = 0.225 mkg) is intended for testing concrete in ordinary building and bridge constructions.

Type NR (Impact energy = 0.225 mkg) corresponds substantially to type N, but it is equipped with a special recording device.

Type L (Impact energy = 0.075 mkg) is a smaller version of type N. It is suitable for testing small and impact-sensitive parts of concrete or artificial stone.

Type LR (Impact energy = 0.075 mkg) corresponds substantially to type L, but is equipped with a special recording device.

Type LB (Impact energy = 0.075 mkg) is particularly suitable for the continuous control of the quality of burnt clay material and tile products.

Type M (Impact energy = 3 mkg) is especially suitable for determining the strength of mass concrete and for testing the quality of concrete road pavements and airfield runways.

Type P (pendulum-type hammer, impact energy = 0.09 mkg) is intended for testing materials of low hardness and strength such as lightweight building materials of every description, plasterwork and surfacings. With concrete of low strength (cube compressive strength 700 to 3500 psi) type P gives better results than the types N and L.

Type PT (Impact energy = 0.09 mkg) with a larger hammer head surface has been developed for testing of building materials with extremely low compressive strength (cube compressive strength of 70 to 1150 psi).

The operating instructions on hand can, in principle, also be applied for the type NR instruments.

The type N concrete test hammer is intended for non-destructive testing of the quality of concrete in the finished structure (ordinary building and bridge construction). When testing, the "Rebound Number" is measured which depends on the strength of the mortar (concrete without coarse aggregate particles) close to the surface. Since the strength of the mortar as a rule determines the strength of the concrete, the rebound number gives an indication of the strength of the concrete.

Compared with the direct test on the concrete of a structure, the conventional test cubes have the disadvantage that their compaction and their hardening conditions always differ more or less from those of the structure; furthermore, differences (unintentional and intentional) in the composition are not uncommon. In addition, the number of test cubes is generally so small that

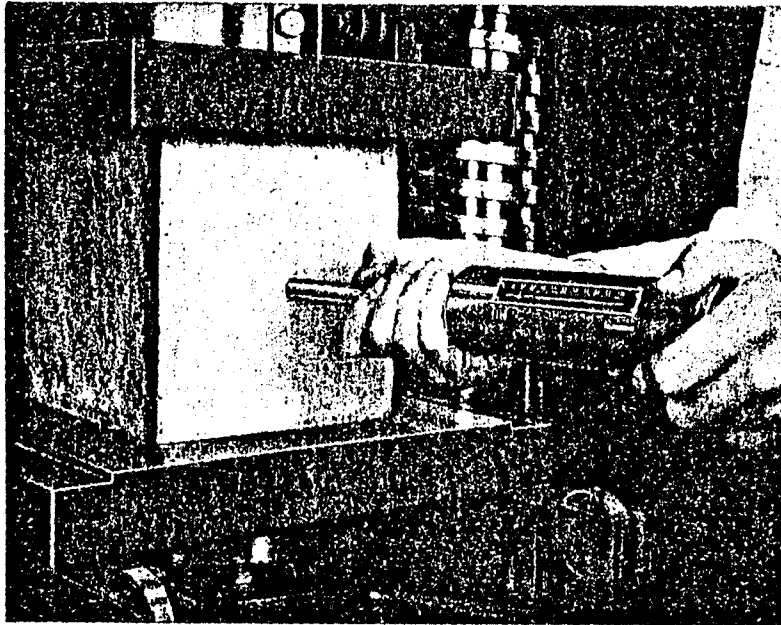

Fig. 1
View of the Concrete Test Hammer Type N during calibration tests with a concrete cube of 20 cm side length at the 'Eidgenössische Materialprüfungsanstalt' (Federal Material Testing Institute) at Zurich.
The cubes are fixed in a heavy crushing press with a force of 4 metric tons. The hammer impacts are equally distributed on two cube sides which have been laying sideways during concreting.

they can only be considered as random tests. With the test hammer, however, all parts even on the largest structures can be tested in a very short time so that it is possible to determine the deviations in the concrete quality over the different parts of the structure. Since the test does not destroy the concrete, the curing process continuing after setting of the cement can be followed up accurately. The correlation between rebound number and strength of the concrete has been derived from a great number of hammer tests on cubes, each cube being crushed in the machine immediately after carrying out the hammer tests (see fig. 1). With concrete of medium and good quality, the uncertainty inherent in this correlation is slight (see fig. 3).

Under normal conditions the accuracy in determining the strength of the concrete of a structure with the test hammer is considerably greater than by means of a few test cubes. The value of the hammer tests is, however, increased if some cubes are produced simultaneously with the various structural parts and their rebound number is determined before being crushed so as to ascertain the exact correlation between rebound number and strength applying to the conditions of the case on hand.

Frequently a definite concrete strength is not specified with regard to the stresses to be expected but to obtain a sufficiently large resistance to wear (such as with concrete road pavements), to erosion (in hydraulic structures) or to climatic influences. In such cases the surface hardness determined with the test hammer is obviously a better measure of quality than the compressive strength.

II. Operating Instructions for the Concrete Test Hammer (Fig. 2)

1. By lightly pressing on the head of the impact plunger (1) the plunger is released and will slide out of the housing (3) by itself.
2. The plunger (1) is pressed against the spot of the concrete surface (2) to be tested. Just before it disappears completely in the housing (3) the hammer is released. Release must be effected by **slowly** increasing the pressure on the housing. At the moment of impact the hammer must be held exactly at right angle to the surface (2). Do not touch the push-button (6)!
3. After the impact the hammer mass (14) rebounds by a certain amount which is indicated on the scale (19) by the rider (4). The reading of the rider position gives the rebound value in percent of the forward movement of the hammer mass.
4. By simply removing the hammer from the spot tested, it is reset for a further test and at the same time the indication is cancelled. The rider never returns quite to zero. In its extended position the plunger (1) is slightly out of the longitudinal axis of the hammer.
5. After having finished the tests, the plunger (1) together with its guide bar (7) and guide disk (8) is locked in its rear position by means of the push-button (6). Locking should always be effected after releasing the impact, i.e. with untensioned impact spring (16). The lock also serves for fixing the rebound reading after impact tests in dark or not easily accessible locations.
6. The test hammer is calibrated for horizontal impact direction, i.e. for testing vertical surfaces. When using it on inclined or horizontal surfaces, the rebound value R_{α} must be corrected as per table I.

Table I Correction of the Test Hammer Indications for Non-horizontal Impacts

Rebound value R_{α}	Correction for inclination angle α			
	upwards		downwards	
	+ 90°	+ 45°	- 45°	- 90°
10			+ 2.4	+ 3.2
20	- 5.4	- 3.5	+ 2.5	+ 3.4
30	- 4.7	- 3.1	+ 2.3	+ 3.1
40	- 3.9	- 2.6	+ 2.0	+ 2.7
50	- 3.1	- 2.1	+ 1.6	+ 2.2
60	- 2.3	- 1.6	+ 1.3	+ 1.7

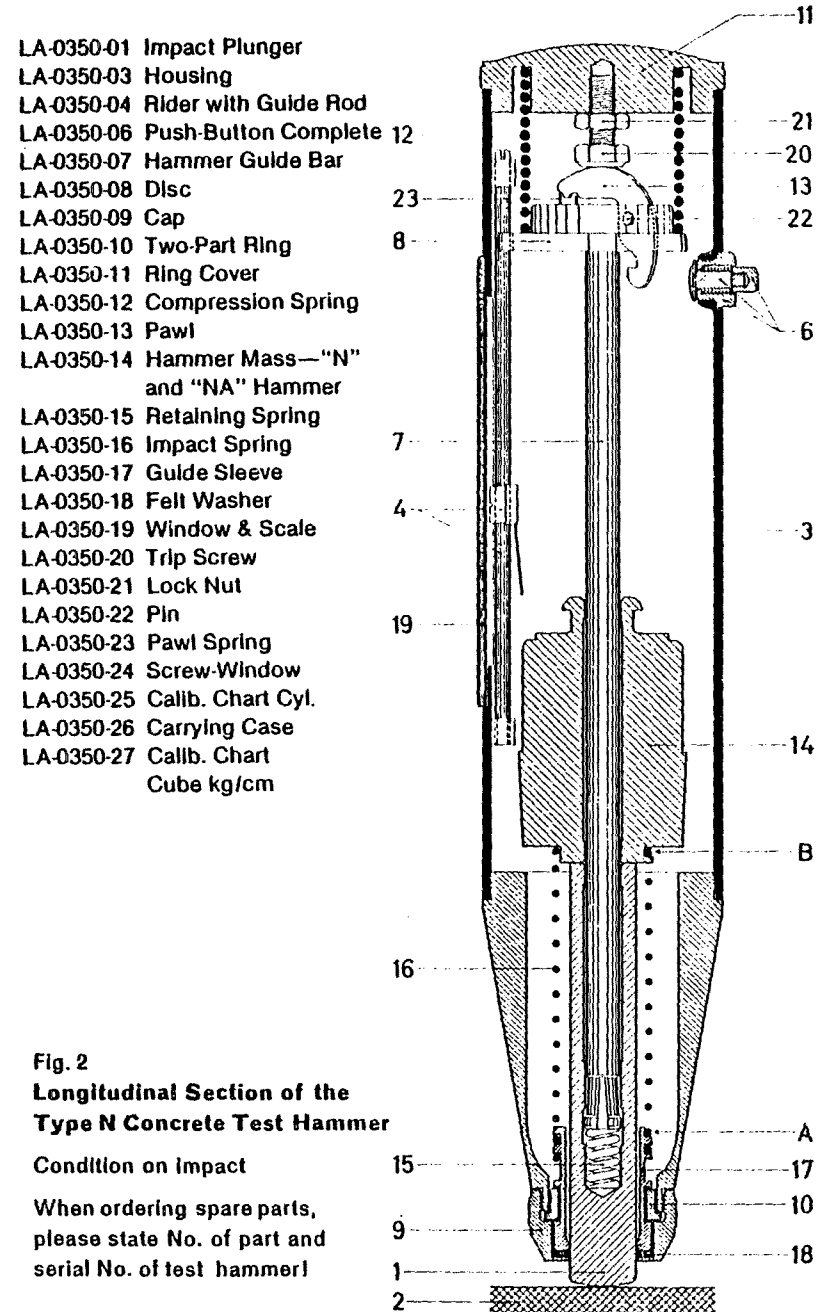

APPENDIX D

COAL AND ROCK DENSITY MEASUREMENTS

APPENDIX D. COAL AND ROCK DENSITY MEASUREMENT

The laboratory coal and rock density measurement procedure is as follows.

1. Place the coal or rock sample into a glass beaker with known volume and mass. This beaker will be referred to as the sample beaker.
2. Weigh the filled sample beaker on a balance scale.
3. Calculate the mass of the coal or rock sample.
4. Pour a known volume of water into the sample beaker.
5. Calculate the sample volume by subtracting the water volume introduced into the sample beaker by the total volume indicated by the water level in the sample beaker.
6. Calculate the sample density by dividing the sample mass by the sample volume.

APPENDIX E

COAL INTERFACE DETECTOR EVALUATION PROGRAM

APPENDIX E. COAL INTERFACE DETECTOR EVALUATION PROGRAM

The data evaluation program is written in Fortran 77 for execution on an IBM PC with 256K memory and two double density disk drives or a hard disk.

The fully interactive program consists of seven routines that arrange and analyze the data as a factorial experiment.

- o Main - directs the program flow.
- o Datas - directs the manual input of test data and the factorial experiment organization.
- o Result - calculates the effectiveness of the CID for each given factorial condition.
- o Stat - calculates the statistics of the factorial experiment.
- o Prtres - Prints the results of the data analysis to a print file for later dump to printer.
- o Manage - manages disk files for program.
- o Ckdata - allows selective printout of data/analysis files.

The programs Main and Data are interactive and hence mostly self-explanatory. The required data is prompted from the user. A separate data file is prepared for each shearer pass. The sequential access data storage is organized as follows.

- o File Name = FILENUMBER.DAT

(File number is the assigned data set number)

DDES	-	character description of the data set, 40 characters or less
IDPT	-	number of data points in the data set
ISERER	-	shearer type (1 through 3)
DISSLD	-	distance between shields or data marks (ft)
CRPM	-	cutter head rpm (rev/min)
DENCOL	-	density of the coal (slugs/ft ³)
DENROK	-	density of the rock (slugs/ft ³)
DCUT(IDPT)	-	depth of cut into rock (in.)
HRDCOL(IDPT)	-	coal hardness by concrete impact hammer test

HRDROK(IDPT) - rock hardness

VEL(IDPT) - average velocity of shearer over last measurement distance (ft/min)

CID - analog signal of the coal interface detector (volts)

- end of file -

The second interactive portion of subprogram DATA is the definition of the factorial experiment to be used to analyze the data. The program user defines the factorial experiment by choosing the factors to be included in the analysis from a displayed list. Each factor is then assigned the number of levels or conditions the variable may take. The levels are defined by assigned lower and upper limits or the variable value. If the number of factors, the number of factor levels, and the variable ranges assigned to each level are adequately selected, each factorial condition should have a significant number of data points. The factorial experiment could be organized as in the following table.

	<u>Factor, X</u>	<u>Level 1</u>	<u>Level 2</u>	<u>Level 3</u>
1.	Range of CID signal for coal cutting	$0 \leq x_1 < 3$	$3 \leq x_1 < 6$	$6 \leq x_1 < 10$
2.	Depth of cut into rock	$0 \leq x_2 < .1$	$.1 \leq x_2 < 2$	$2 \leq x_2 < 6$
3.	Coal/rock hardness ratio	$.1 \leq x_3 < .25$	$.25 \leq x_3 < .75$	$.75 \leq x_3 < 1$

If organized in this manner, other possible factors such as shearer velocity, shearer type, etc. have been assumed inconsequential.

The data that defines the factorial experiment organization to be imposed on the raw data is stored in another sequential access file as follows.

o File Name = STAT.SET

NREP - number of replications

NDSPR - number of data sets per replication

NF - number of factors

MNL - maximum number of levels of any factor

NFAC(NF) - name of each factor

IDR(NREP, NDSPR) - data sets assigned to each replication

NL(NF) - number of levels for each factor

FACLEV(NF,MNL,2) - low and high factor levels for each factor.

The subprogram, RESULT, examines each data vector and assigns the data to the applicable factorial condition. It then evaluates the success or failure of the CID in signaling the actual cutting condition at each data point. The final results of the experiment are in terms of the percentage of data points at which the CID gives the correct cutting condition signal. This percentage is calculated for each factorial condition.

The subprogram, STAT, conducts a statistical analysis of variance to establish the significance of the individual and joint effects of the chosen factors (variables) on the CID effectiveness.

The calculated results of the subprograms RESULT and STAT are stored on a sequential access file as follows.

File Name = STAT.RES

BRES(4,4,4,4,NREP)	-	percentage of correct signals
NDPRES(4,4,4,4,NREP)	-	number of data points in each factorial condition
TABLE(16,4)	-	statistical table of results

D Line# 1 7

```
1 $PAGESIZE:60
2 $LARGE
3 $DEBUG
4 C      **** COAL INTERFACE DETECTOR EVALUATION PROGRAM ****
5 C
6 C      ****
7 C      *THIS DATA EVALUATION PROGRAM IS WRITTEN IN FORTRAN *
8 C      *77 FOR EXECUTION ON AN IBM PC WITH 256K MEMORY AND *
9 C      *TWO DOUBLE DENSITY DISK DRIVES OR A HARD DISK. *
10 C     * *
11 C     *THE FULLY INTERACTIVE PROGRAM CONSISTS OF SEVEN *
12 C     *ROUTINES THAT ARRANGE AND ANALYZE THE DATA AS A *
13 C     *FACTORIAL EXPERIMENT: *
14 C     * *
15 C     * MAIN- DIRECTS THE PROGRAM FLOW *
16 C     * *
17 C     * DATAS- DIRECTS THE MANUAL INPUT OF TEST DATA AND *
18 C     * THE FACTORIAL EXPERIMENT ORGANIZATION *
19 C     * *
20 C     * RESULT- CALCULATES THE EFFECTIVENESS OF THE CID *
21 C     * FOR EACH GIVEN FACTORIAL CONDITION *
22 C     * *
23 C     * STAT- CALCULATES THE STATISTICS OF THE FACTORIAL *
24 C     * EXPERIMENT *
25 C     * *
26 C     * PRTRES- PRINTS THE RESULTS OF THE DATA ANALYSIS *
27 C     * TO A PRINTFILE FOR LATER DUMP TO PRINTER *
28 C     * *
29 C     * MANAGE- MANAGES DISK FILES FOR PROGRAM *
30 C     * *
31 C     * CKDATA- ALLOWS SELECTIVE PRINTOUT OF DATA/ANALY- *
32 C     * SIS FILES *
33 C     ****
34 C
35 C
36 C      **** MAIN (ROOT) PROGRAM ****
37 C
38     DIMENSION DATARY(8,500),NFAC(4),IDR(4,30),NL(4),FACLEV(4,4,2),BREI
39     #(4,4,4,4,4),NDPRES(4,4,4,4,4),TABLE(17,4)
40 C
41 C     ESTABLISH GLOBAL MAXIMUM SIZING
42 C
43     NDSFR=30
44     NREP=4
45     MIDPT=500
46     NF=4
47     MNL=4
48     J5=4
49     J6=4
50     J7=4
51     J8=4
52 C
53 C     MAIN MENU SELECTION
```

```

Line# 1      7
54 C
55 1      WRITE(*,1000)
56      READ(*,*) IANA
57      IF (IANA.LE.2) CALL DATAS (IANA,MIDPT,NF,MNL,NDSFR,DATARY,NFAC,IDR,N
58 #L,FACLEV,NREP)
59      IF (IANA.GE.3.AND.IANA.LE.5) CALL RESULT (IANA,MIDPT,NF,MNL,NDSFR,DA
60 #TARY,NFAC,IDR,NL,FACLEV,NREP,J5,J6,J7,J8,NDPRES,BRES)
61      IF (IANA.EQ.6) CALL STAT (NF,MNL,NL,NREP,J5,J6,J7,J8,NDPRES,BRES,TAB
62 #LE)
63      IF (IANA.EQ.7) CALL PRTRES (NF,MNL,NL,NREP,J5,J6,J7,J8,NDPRES,BRES,T
64 #ABLE,IDR,NDSFR,FACLEV,NFAC)
65      IF (IANA.EQ.8) CALL CKDATA
66      IF (IANA.EQ.9) GO TO 5000
67      GO TO 1
68 C
69 C      FORMAT STATEMENTS
70 C
71 1000   FORMAT(1H1,18X,'COAL INTERFACE DETECTOR EVALUATION PROGRAM'/1H ,6X
72 #,'MAIN MENU'/1H ,6X,'-----'/1H ,8X,'*SELECT:'/1H ,10X,'1. DATA
73 # ENTRY (PREREQUISITE TO #2,3,4,AND 5).'/1H0,10X,'2. DATA ANALYSIS
74 #SETUP (PREREQUISITE TO #3,4,AND 5).'/1H0,10X,'3. RUN DATA ANALYSIS
75 #EVALUATING THE PERCENTAGE OF DATA POINTS'/1H ,14X,'WITH THE CORRE
76 #CT CUTTING CONDITION SIGNAL.'/1H0,10X,'4. RUN DATA ANALYSIS EVALUA
77 #TING THE PERCENTAGE OF DATA POINTS'/1H ,14X,'WHERE ROCK WAS BEING
78 #CUT WITH THE CORRECT CONDITION SIGNAL.'/1H0,10X,'5. RUN DATA ANAL
79 #YSIS EVALUATING THE PERCENTAGE OF DATA POINTS'/1H ,14X,'WHERE COAL
80 # WAS BEING CUT WITH THE CORRECT CONDITION SIGNAL.'/1H0,10X,'6. RUN
81 # STATISTICAL ANALYSIS.'/1H0,10X,'7. PRINT RESULTS TO PRINTFILE.'/1
82 #H0,10X,'8. SELECT AND DUMP DATA/ANALYSIS FILES TO PRINTER FOR CHEC
83 #K.'/1H0,10X,'9. EXIT PROGRAM.'/1H ,2X,'ENTER NUMBER OF CHOICE:')
84 5000   STOP
85      END

```

ame	Type	Offset	P	Class
RES	REAL	0		LARGE
DATARY	REAL	0		LARGE
FACLEV	REAL	0		LARGE
IANA	INTEGER*4	52		
IDR	INTEGER*4	0		LARGE
J5	INTEGER*4	36		
J6	INTEGER*4	40		
J7	INTEGER*4	44		
J8	INTEGER*4	48		
MIDPT	INTEGER*4	24		
NL	INTEGER*4	32		
NDPRES	INTEGER*4	480		LARGE
NDSFR	INTEGER*4	16		
NREP	INTEGER*4	28		
NFAC	INTEGER*4	16000		LARGE
NL	INTEGER*4	16016		LARGE
NF	INTEGER*4	20		
TAB	REAL	16032		LARGE

D Line# 1 7

Microsoft FORTRAN77 V3.20 02/84

Name	Type	Size	Class
CKDATA			SUBROUTINE
DATAS			SUBROUTINE
MAIN			PROGRAM
PRTRES			SUBROUTINE
RESULT			SUBROUTINE
STAT			SUBROUTINE

Pass One No Errors Detected
85 Source Lines

```
Line# 1      7
1  $PAGESIZE:60
2  $LARGE
3  $DEBUG
4  C
5  C          ***** SUBROUTINE DATAS *****
6  C
7  SUBROUTINE DATAS(IANA,MIDPT,NF,MNL,NDSPR,DATARY,NFAC,IDR,NL,FACLE
8  #V,NREP)
9  C
10 C  TYPE AND DIMENSION STATEMENTS
11 C
12 CHARACTER DDES*50
13 DIMENSION DATARY(8,500),NFAC(4),IDR(4,30),NL(4),FACLEV(4,4,2)
14 C
15 C  ENTER DATA ENTRY OR DATA ANALYSIS SETUP
16 C
17 IF (IANA.GT.1)GOTO 40
18 C
19 C  DATA ENTRY MAIN MENU
20 C
21 10 WRITE(*,1010)
22 READ(*,*)I
23 IF(I.EQ.1)GO TO 20
24 IF(I.EQ.2)GO TO 35
25 GO TO 2000
26 C
27 C  DATA ENTRY: FACE AND OPERATING CONDITIONS
28 C
29 20 WRITE(*,1020)
30 WRITE(*,1030)
31 READ(*,*)ID
32 ID=ID+101
33 C
34 C  CHECK FILE STATUS IN SUBROUTINE MANAGE
35 C
36 CALL MANAGE(ID,S)
37 IF (S.NE.3) THEN
38 WRITE(*,1035)'FACE AND OPERATING CONDITIONS'
39 READ(*,*)IQ
40 IF (IQ.NE.1) GOTO 10
41 REWIND ID
42 READ(ID,'(A)')DDES
43 READ(ID,*)IDPT,ISERER,DISSLD,CRPM,DENCOL,DENROK,(DATARY(2,J),J=1,I
44 #DPT),(DATARY(3,J),J=1,IDPT),(DATARY(4,J),J=1,IDPT),(DATARY(6,J),J=
45 #1,IDPT),(DATARY(1,J),J=1,IDPT)
46 ENDIF
47 WRITE(*,1040)
48 READ(*,'(A)')DDES
49 WRITE(*,1050)
50 READ(*,*)IDPT
51 WRITE(*,1060)
52 READ(*,*)ISERER
53 WRITE(*,1070)
```

```
D Line# 1      7
54      READ(*,*)CRPM
55      WRITE(*,1080)
56      READ(*,*)DENCOL
57      WRITE(*,1090)
58      READ(*,*)DENROK
59      WRITE(*,1100)
60      READ(*,*)DISSLD
61 25      WRITE(*,1110)
62      WRITE(*,1115)
63      READ(*,*)N
64      IF(N.LT.0)GO TO 30
65      WRITE(*,1116)
66      READ(*,*)DATARY(2,N),DATARY(3,N),DATARY(4,N),DATARY(6,N)
67      GO TO 25
68 30      CONTINUE
69 C
70 C      STORE DATA AND RETURN CONTROL TO DATA ENTRY MENU
71 C
72      REWIND ID
73 31      WRITE(ID,*)DDES
74      WRITE(ID,*)IDPT,ISERER,DISSLD,CRPM,DENCOL,DENROK,(DATARY(2,J),J=1,
75      #IDPT),(DATARY(3,J),J=1,IDPT),(DATARY(4,J),J=1,IDPT),(DATARY(6,J),J
76      #=1,IDPT),(DATARY(1,J),J=1,IDPT)
77      CLOSE (ID,STATUS='KEEP')
78      GO TO 10
79 C
80 C      DATA ENTRY: COAL INTERFACE DETECTOR ANALOG SIGNAL
81 C
82 35      WRITE(*,1120)
83      WRITE(*,1130)
84      READ(*,*)ID1
85      ID1=ID1+101
86      WRITE(*,1140)
87      READ(*,*)IDPT1
88      CALL MANAGE(ID1,S)
89      IF (S.NE.3) THEN
90      WRITE(*,1035)'COAL INTERFACE DETECTOR ANALOG SIGNAL'
91      READ(*,*)IQ
92      IF (IQ.NE.1)GOTO 10
93      ENDIF
94 C
95 C      READ FACE CONDITION DATA FROM FILE
96 C
97      REWIND ID1
98      READ(ID1,'(A)')DDES
99      READ(ID1,*)IDPT,ISERER,DISSLD,CRPM,DENCOL,DENROK,(DATARY(2,J),J=1,
100     #IDPT),(DATARY(3,J),J=1,IDPT),(DATARY(4,J),J=1,IDPT),(DATARY(6,J),J
101     #=1,IDPT),(DATARY(1,J),J=1,IDPT)
102      IF(IDPT.NE.IDPT1)GO TO 10
103 C
104 C      LOAD THE COAL INTERFACE DETECTOR VALUES
105 C
106 36      WRITE(*,1150)
```

```

Line# 1      7
107      WRITE(*,1160)
108      READ(*,*)N
109      IF(N.LT.0)GO TO 37
110      WRITE(*,1170)
111      READ(*,*)DATARY(1,N)
112      GO TO 36
113 37     CONTINUE
114 C
115 C      RESTORE THE FACE CONDITION DATA AND THE COAL INTERFACE DETECTOR
116 C      DATA
117 C
118      REWIND ID1
119      WRITE(ID1,*)DDES
120      WRITE(ID1,*)IDPT,ISERER,DISSLD,CRPM,DENCOL,DENROK,(DATARY(2,J),J=1
121 #,IDPT),(DATARY(3,J),J=1,IDPT),(DATARY(4,J),J=1,IDPT),(DATARY(6,J),
122 #J=1,IDPT),(DATARY(1,J),J=1,IDPT)
123      CLOSE (ID1,STATUS='KEEP')
124      GO TO 10
125 C
126 C      DATA ANALYSIS SETUP
127 C
128 C
129 C      ZERO THE IDR ARRAY
130 C
131 40     DO 41 I=1,4
132      DO 41 J=1,30
133 41     IDR(I,J)=0
134      DO 42 I=1,4
135      DO 42 J=1,4
136      DO 42 K=1,2
137 42     FACLEV(I,J,K)=0.0
138      WRITE(*,1200)
139      WRITE(*,1210)
140      READ(*,*)NREP
141      WRITE(*,1220)
142      READ(*,*)NDSFR
143 45     WRITE(*,1230)
144      WRITE(*,1235)
145      READ(*,*)N
146      IF(N.LT.0)GO TO 50
147      WRITE(*,1236)
148      READ(*,*)(IDR(N,J),J=1,NDSFR)
149      DO 46 J=1,NDSFR
150 46     IDR(N,J)=IDR(N,J)+101
151      GO TO 45
152 50     CONTINUE
153      WRITE(*,1240)
154      READ(*,*)NF
155      WRITE (*,1250)
156      READ(*,*)MNL
157      DO 54 I=1,4
158 54     NL(I)=1.0
159 55     WRITE(*,1260)

```

```
D Line# 1      7
160          WRITE(*,1265)
161          READ(*,*)N
162          IF(N.LT.0)GO TO 60
163          WRITE(*,1266)
164          READ(*,*)NFAC(N),NL(N)
165          GO TO 55
166 60        CONTINUE
167 65        WRITE(*,1270)
168          WRITE(*,1280)
169          READ(*,*)N
170          IF(N.LT.0)GO TO 70
171          WRITE(*,1290)
172          READ(*,*)IFL,FACLEV(N,IFL,1),FACLEV(N,IFL,2)
173          GO TO 65
174 70        CONTINUE
175 C
176 C          STORE ANALYSIS SETUP AND RETURN CONTROL TO MAIN MENU
177 C
178          OPEN(100,FILE='B:STAT.SET',STATUS='NEW')
179          WRITE(100,*)NREP,NDSPR,NF,MNL,NFAC,IDR,NL,FACLEV
180          CLOSE(100,STATUS='KEEP')
181 C
182 C          FORMAT STATEMENTS
183 C
184 1010       FORMAT('1',6X,'DATA ENTRY'/1H ,6X,'-----'/1H0,8X,'*SELECT: '/1
185           #H0,10X,'1. FACE AND OPERATING CONDITIONS INPUT. '/1H0,10X,'2. COAL
186           #INTERFACE DETECTOR ANALOG SIGNAL INPUT. '/1H0,10X,'3. RETURN TO MAI
187           #N MENU. '/1H0,2X,'ENTER NUMBER OF CHOICE: '/)
188 1020       FORMAT('1',6X,'DATA ENTRY : FACE AND OPERATING CONDITIONS'/1H ,6X,
189           #'-----')
190 1030       FORMAT(1H0,9X,'*DATA SET ID NUMBER? (1-898)')
191 1035       FORMAT(1H0,10X,'FILE EXISTS AND IS OPEN. '/1H ,10X,'DO YOU WANT TO
192           #CHANGE ',A,' DATA?'/1H0,10X,'INPUT 1 FOR YES OR 2 FOR NO')
193 1040       FORMAT(1H0,9X,'*DATA SET DESCRIPTION (50 CHARACTERS MAX.) ?')
194 1050       FORMAT(1H0,9X,'*NUMBER OF DATA POINTS IN THE DATA SET ?')
195 1060       FORMAT(1H0,9X,'*SHEARER TYPE FOR DATA SET : '/1H ,11X,'1. JOY'/1H
196           #11X,'2. ANDERSON MAJOR'/1H ,11X,'3. EICKOFF 150'/1H ,11X,'4. MISU
197           #MIKE'/1H0,2X,'ENTER NUMBER OF CHOICE: ')
198 1070       FORMAT(1H0,9X,'*CUTTERHEAD RPM (RPM) ?')
199 1080       FORMAT(1H0,9X,'*BULK DENSITY OF COAL (SLUGS/FT**3) ?')
200 1090       FORMAT(1H0,9X,'*BULK DENSITY OF ROCK (SLUGS/FT**3) ?')
201 1100       FORMAT(1H0,9X,'*DISTANCE BETWEEN SHIELD MARKS (FT) ?')
202 1110       FORMAT('1',9X,'*ENTER "/1H ,11X,'SHIELD NUMBER. '/1H ,11X,'DEPTH
203           #F CUT (IN.),COAL HARDNESS,ROCK HARDNESS,AVERAGE SPEED (FT/MIN)'/1
204           #0,13X,'-IF A NUMBER IS ENTERED INCORRECTLY, SIMPLY REPEAT THE TWO
205           #/1H ,15X,'ENTRIES WITH THE CORRECT VALUES. '/1H0,13X,'-EXIT THE F
206           #E AND OPERATING CONDITIONS DATA ENTRY BY ENTERING'/1H ,15X,'A NE
207           #TIVE SHIELD NUMBER.')
208 1115       FORMAT(1H0,5X,'INPUT SHIELD NUMBER')
209 1116       FORMAT(1H0,5X,'INPUT DEPTH OF CUT (IN),COAL HARDNESS,ROCK HARDNE
210           #,AVERAGE SPEED (FT/MIN)')
211 1120       FORMAT('1',6X,'DATA ENTRY : CID ANALOG SIGNAL'/1H ,6X,'-----
212           #)
```

```

Line# 1      7      Microsoft FORTRAN77 V3.20 02/84
213 1130  FORMAT(1H0,9X,'*DATA SET ID NUMBER ? (1-898)')
214 1140  FORMAT(1H0/1H0,9X,'*NUMBER OF DATA POINTS IN DATA SET ? (CHECKED
215      #AGAINST NUMBER'/1H ,11X,'ON FACE CONDITION FILE. PROGRAM ABORT IF
216      #NUMBERS DO NOT MATCH)')
217 1150  FORMAT(1H0,9X,'*ENTER :'/1H ,11X,'SHIELD NUMBER.'/1H ,11X,'CID SIG
218      #NAL LEVEL.'/1H0,13X,'-IF A NUMBER IS ENTERED INCORRECTLY, SIMPLY R
219      #PEAT THE TWO'/1H ,15X,'ENTRIES WITH THE CORRECT VALUES.'/1H0,13X,
220      #'EXIT THE CID SIGNAL LEVEL DATA ENTRY BY ENTERING A NEGATIVE'/1H ,
221      #15X,'SHIELD NUMBER.')
222 1160  FORMAT(1H0,5X,'INPUT SHIELD NUMBER')
223 1170  FORMAT(1H0,5X,'INPUT CID SIGNAL LEVEL')
224 1200  FORMAT('1',6X,'DATA ANALYSIS SETUP :'/1H ,6X,'-----'
225      #/1H0,9X,'THE DATA REQUIRED FOR THE CID EVALUATION IS STORED IN DAT
226      #A SETS.'/1H ,6X,'EACH DATA SET CONTAINS THE DATA FROM ONE SHEARER
227      #CUTTING PASS. THE'/1H ,6X,'NUMBER OF DATA POINTS IN EACH DATA SET
228      #IS NOT REQUIRED TO BE'/1H ,6X,'CONSTANT BUT MUST BE LESS THAN 500.
229      #THE DATA IS ANALYZED AS A'/1H ,6X,'FACTORIAL EXPERIMENT. THE EXPE
230      #RIMENT ORGANIZATION IS DEFINED BELOW.')
231 1210  FORMAT(1H0/1H ,9X,'*TOTAL NUMBER OF REPLICATIONS OF THE EXPERIMENT
232      # ?')
233 1220  FORMAT(1H0,9X,'*MAXIMUM NUMBER OF DATA SETS PER REPLICATION ?')
234 1230  FORMAT(1H0,9X,'*ENTER :'/1H ,11X,'REPLICATION NUMBER'/1H ,11X,'DAT
235      #A SETS ASSIGNED TO THE REPLICATION'/1H0,13X,'-IF A NUMBER IS ENTER
236      #ED INCORRECTLY, SIMPLY REPEAT ENTRY'/1H ,15X,'WITH CORRECT VALUES.
237      #'/1H0,13X,'-EXIT DATA SET ASSIGNMENT BY ENTERING A NEGATIVE NUMBER
238      # FOR'/1H ,15X,'THE REPLICATION.')
239 1235  FORMAT(1H0,10X,'INPUT REPLICATION NUMBER')
240 1236  FORMAT(1H0,10X,'INPUT DATA SETS ASSIGNED TO REPLICATION')
241 1240  FORMAT('1',9X,'*NUMBER OF FACTORS TO BE CONSIDERED ?')
242 1250  FORMAT(1H0,9X,'*MAXIMUM NUMBER OF LEVELS PER FACTOR ?')
243 1260  FORMAT(1H0,9X,'*FACTOR ASSIGNMENT. ENTER :'/1H ,11X,'FACTOR NUMBER
244      #.'/1H ,11X,'FACTOR TYPE, MAXIMUM LEVEL OF FACTOR'/1H0,10X,'CHOOSE
245      #FROM :'/1H ,10X,'1. CID ANALOG SIGNAL CUTTING BAND (REQUIRED FIRST
246      # FACTOR)'/1H0,10X,'2. DEPTH OF CUT INTO ROCK.'/1H0,10X,'3. AND 4.
247      # NOT USED.'/1H0,10X,'5. COAL/ROCK HARDNESS RATIO.'
248      #/1H0,10X,'6. SHEARER VELOCITY.'/1H0,10X,'7. SHEARER TYPE.'
249      #/1H0,13X,'-IF A NUMBER IS ENTERED INCORRECTLY, SIMPLY REPEAT ENTRY
250      #.'/1H0,13X,'-EXIT FACTOR ASSIGNMENT BY ENTERING A NEGATIVE NUMBER
251      #FOR THE'/1H ,15X,'FACTOR.')
252 1265  FORMAT(1H0,10X,'INPUT FACTOR NUMBER')
253 1266  FORMAT(1H0,10X,'INPUT FACTOR TYPE (1-7) AND MAXIMUM LEVEL OF FACTO
254      #R')
255 1270  FORMAT('1',9X,'*ENTER LIMITS CHOSEN FOR FACTOR LEVELS (FILL ARRAY
256      #FACLEV(NF,MNL,2))'/1H ,12X,'FACTOR NUMBER'/1H ,12X,'LEVEL NUMBER ,
257      # LOW , HIGH'/1H0,13X,'-IF A NUMBER IS ENTERED INCORRECTLY, SIMPLY
258      #REPEAT ENTRY.'/1H0,13X,'-EXIT FACTOR LEVEL ASSIGNMENT BY ENTERING
259      #A NEGATIVE FACTOR'/1H ,15X,'NUMBER.')
260 1280  FORMAT(1H0,10X,'INPUT FACTOR NUMBER, N')
261 1290  FORMAT(1H0,10X,'INPUT LEVEL NUMBER, LOW FACTOR LEVEL, HIGH FACTOR
262      #LEVEL')
263 C
264 C      RETURN TO MAIN PROGRAM
265 C

```

D Line# 1 7
266 2000 RETURN
267 END

Name	Type	Offset	P	Class
CRPM	REAL	94		
DATARY	REAL	20	*	
DDES	CHAR*50	32		
DENCOL	REAL	98		
DENROK	REAL	102		
DISSLD	REAL	90		
FACLEV	REAL	36	*	
I	INTEGER*4	16		
IANA	INTEGER*4	0	*	
ID	INTEGER*4	20		
ID1	INTEGER*4	134		
IDPT	INTEGER*4	82		
IDFT1	INTEGER*4	138		
IDR	INTEGER*4	28	*	
IFL	INTEGER*4	150		
IQ	INTEGER*4	28		
ISERER	INTEGER*4	86		
J	INTEGER*4	106		
K	INTEGER*4	142		
MIDPT	INTEGER*4	4	*	
MNL	INTEGER*4	12	*	
N	INTEGER*4	130		
NDSPR	INTEGER*4	16	*	
NF	INTEGER*4	8	*	
NFAC	INTEGER*4	24	*	
NL	INTEGER*4	32	*	
NREP	INTEGER*4	40	*	
S	REAL	24		

Name	Type	Size	Class
DATAS			SUBROUTINE
MANAGE			SUBROUTINE

Pass One No Errors Detected
267 Source Lines

```

Line# 1      7      Microsoft FORTRAN77 V3.20 02/84
 1 #PAGESIZE:60
 2 #LARGE
 3 #DEBUG
 4 C
 5 C          ***** SUBROUTINE RESULT *****
 6 C
 7      SUBROUTINE RESULT (IANA,MIDPT,NF,MNL,NDSFR,DATARY,NFAC,IDR,NL,FACL
 8 #EV,NREP,J5,J6,J7,J8,NDPRES,BRES)
 9 C
10 C      TYPE AND DIMENSION STATEMENTS
11 C
12      LOGICAL*2 YES
13      CHARACTER*50 DDES
14      DIMENSION DATARY(8,500),NFAC(4),IDR(4,30),NL(4),FACLEV(4,4,2),BRES
15 #(4,4,4,4,4),NDPRES(4,4,4,4,4)
16 C
17 C      READ ANALYSIS FILE AND INITIALIZE ARRAYS TO ZERO
18 C
19      OPEN(100,FILE='B:STAT.SET',STATUS='OLD')
20      READ(100,*)NREP,NDSFR,NF,MNL,NFAC,IDR,NL,FACLEV
21      CLOSE(100)
22      DO 5 I=1,4
23      DO 5 J=1,4
24      DO 5 K=1,4
25      DO 5 L=1,4
26      DO 5 M=1,4
27      BRES(I,J,K,L,M)=0.0
28      NDPRES(I,J,K,L,M)=0.0
29 5      CONTINUE
30 C
31 C      REPLICATION DO-LOOP
32 C
33      DO 1000 M=1,NREP
34 C
35 C      DATA SETS THAT ARE PART OF THE REPLICATION INCLUDED HERE
36 C
37      DO 1000 M2=1,NDSFR
38 C
39 C      FILL DATA ARRAY ACCORDING TO THE SELECTED DATA ANALYSIS STRUCTURE
40 C      FROM THE STORED DATA SET, IDR(M,M2)
41 C
42      IR=IDR(M,M2)
43      CALL MANAGE(IR,S)
44      IF (S.EQ.3) RETURN
45      IF (S.EQ.1) REWIND IR
46      READ(IR,'(A)')DDES
47      READ(IR,*)IDPT
48 C
49 C      INITIALIZE DATA ARRAY
50 C
51      DO 10 I=1,7
52      DO 10 J=1,IDPT
53      DATARY(I,J)=0.0

```

```

D Line# 1      7
4      54 10   CONTINUE
2      55     REWIND IR
2      56     READ(IR, '(A)') DDES
2      57     READ(IR,*) IDPT, ISERER, DISSLD, CRPM, DENCOL, DENROK, (DATARY(2,I), I=1,
2      58     #DPT), (DATARY(3,I), I=1, IDPT), (DATARY(4,I), I=1, IDPT), (DATARY(6,I), I
2      59     #1, IDPT), (DATARY(1,I), I=1, IDPT)
2      60     CLOSE (IR, STATUS='KEEP')
2      61 C
2      62 C     CALCULATE COAL/ROCK HARDNESS RATIO AND STORE, ALSO STORE SHEARER
2      63 C     TYPE IN DATARY
2      64 C
2      65     DO 15 I=1, IDPT
3      66     DATARY(5,I)=DATARY(3,I)/DATARY(4,I)
3      67     WRITE(*,*) I, DATARY(5,I)
3      68 15    CONTINUE
2      69     DO 20 I=1, IDPT
3      70     DATARY(7,I)=ISERER
3      71 20    CONTINUE
2      72 C
2      73 C     MAXIMUM OF FOUR FACTORS ALLOWED. SELECT THE FACTORIAL CONDITION
2      74 C     INTO WHICH EACH DATA POINT FALLS.
2      75 C
2      76     DO 900 I=1, NL(1)
3      77     DO 900 J=1, NL(2)
4      78     DO 900 K=1, NL(3)
5      79     DO 900 L=1, NL(4)
6      80     DO 500 ID=1, IDPT
7      81     ICT=1
7      82     IF (DATARY(NFAC(2), ID).GE.FACLEV(2,J,1).AND.DATARY(NFAC(2), ID).LT.
7      83     #ACLEV(2,J,2)) ICT=ICT+1
7      84     IF (NF.EQ.2) GOTO 30
7      85     IF (DATARY(NFAC(3), ID).GE.FACLEV(3,K,1).AND.DATARY(NFAC(3), ID).LT.
7      86     #ACLEV(3,K,2)) ICT=ICT+1
7      87     IF (NF.EQ.3) GOTO 30
7      88     IF (DATARY(NFAC(4), ID).GE.FACLEV(4,L,1).AND.DATARY(NFAC(4), ID).LT.
7      89     #ACLEV(4,L,2)) ICT=ICT+1
7      90 30    IF (ICT.LT.NF) GO TO 500
7      91 C
7      92 C     ADD THE DATA POINT TO THE COUNT ARRAY NDPRES(I,J,K,L,M)
7      93 C
7      94     IF (IANA.EQ.4.AND.DATARY(2, ID).EQ.0.0) GO TO 500
7      95     IF (IANA.EQ.5.AND.DATARY(2, ID).GT.0.0) GO TO 500
7      96     NDPRES(I,J,K,L,M)=NDPRES(I,J,K,L,M)+1
7      97 C
7      98 C     DECIDE IF CID INDICATION IS CORRECT
7      99 C     USE ALL DATA POINTS, IANA=3 CHOICE
7     100 C
7     101     IF (DATARY(1, ID).GE.FACLEV(1,I,1).AND.DATARY(1, ID).LT.FACLEV(1,I
7     102     #) BRES(I,J,K,L,M)=BRES(I,J,K,L,M)+1
7     103 500   CONTINUE
6     104 900   CONTINUE
2     105 1000  CONTINUE
2     106 C

```

```

Line# 1      7
107 C      CONVERT BRES INTO PERCENTAGE
108 C
109        DO 1010 I=1,NL(1)
110        DO 1010 J=1,NL(2)
111        DO 1010 K=1,NL(3)
112        DO 1010 L=1,NL(4)
113        DO 1010 M=1,NREP
114          IF (NDPRES(I,J,K,L,M).EQ.0) THEN
115            BRES(I,J,K,L,M)=0.0
116          ELSE
117            BRES(I,J,K,L,M)=BRES(I,J,K,L,M)/NDPRES(I,J,K,L,M)*100
118          END IF
119 1010    CONTINUE
120 C
121 C      STORE RESULTS OF EXPERIMENT IN FILE 101
122 C
123        OPEN(101,FILE='B:RES.RES',STATUS='NEW')
124        WRITE(101,*) IANA,NDPRES,BRES
125        CLOSE(101,STATUS='KEEP')
126 C
127 C      RETURN TO MAIN PROGRAM
128 C
129        RETURN
130        END
  
```

ame	Type	Offset	P	Class
RES	REAL	64	*	
RPM	REAL	126		
ATARY	REAL	20	*	
DES	CHAR*50	60		
ENCDL	REAL	130		
ENROK	REAL	134		
SSLD	REAL	122		
CLEV	REAL	36	*	
	INTEGER*4	20		
NA	INTEGER*4	0	*	
T	INTEGER*4	190		
	INTEGER*4	182		
PT	INTEGER*4	110		
	INTEGER*4	28	*	
	INTEGER*4	52		
IRER	INTEGER*4	118		
	INTEGER*4	24		
	INTEGER*4	44	*	
	INTEGER*4	48	*	
	INTEGER*4	52	*	
	INTEGER*4	56	*	
	INTEGER*4	28		
	INTEGER*4	32		
	INTEGER*4	36		
	INTEGER*4	44		
IT	INTEGER*4	4	*	

```
D Line# 1      7
MNL    INTEGER*4      12 *
NDPRES INTEGER*4      60 *
NDSFR  INTEGER*4      16 *
NF     INTEGER*4       8 *
NFAC   INTEGER*4      24 *
NL     INTEGER*4      32 *
NREF   INTEGER*4      40 *
S      REAL           56
YES    LOGICAL*2      *****
```

Name	Type	Size	Class
MANAGE			SUBROUTINE
RESULT			SUBROUTINE

Pass One No Errors Detected
 130 Source Lines

```
Line# 1      7
1  $PAGESIZE:60
2  $LARGE
3  $DEBUG
4  C
5  C          ***** SUBROUTINE STAT *****
6  C
7  SUBROUTINE STAT(NF,MNL,NL,NREP,J5,J6,J7,J8,NDPRES,BRES, TABLE)
8  C
9  C  TYPE AND DIMENSION STATEMENTS
10 C
11  DIMENSION NL(4),BRES(4,4,4,4,4),TABLE(17,4),NDPRES(4,4,4,4,4)
12  OPEN(101,FILE='B:RES.RES',STATUS='OLD')
13  OPEN(10,FILE='LPT1',STATUS='NEW')
14  READ(101,*)IANA,NDPRES,BRES
15 C
16 C  INITIALIZE STATISTICAL VARIABLES
17 C
18  SST=0.0
19  SSTR=0.0
20  SSR=0.0
21  SS1=0.0
22  SS2=0.0
23  SS3=0.0
24  SS4=0.0
25  SS12=0.0
26  SS13=0.0
27  SS14=0.0
28  SS23=0.0
29  SS24=0.0
30  SS34=0.0
31  SS123=0.0
32  SS124=0.0
33  SS234=0.0
34  SS134=0.0
35  SS1234=0.0
36  SSE=0.0
37  CC=0.0
38  DO 05 I=1,17
39  DO 05 J=1,4
40  TABLE(I,J)=0.0
41 05  CONTINUE
42 C
43 C  CALCULATE THE CORRECTION FACTOR CC
44 C
45  SUM=0.0
46  DO 10 I=1,NL(1)
47  DO 10 J=1,NL(2)
48  DO 10 K=1,NL(3)
49  DO 10 L=1,NL(4)
50  DO 10 M=1,NREP
51 10  SUM=SUM+BRES(I,J,K,L,M)
52  CC=SUM**2/(NL(1)*NL(2)*NL(3)*NL(4)*NREP)
53 C
```

```

D Line# 1 7 Microsoft FORTRAN77 V3.20 02/8
54 C CALCULATE TOTAL SUM OF THE SQUARES,SST
55 C
56 SUM=0.0
57 DO 20 I=1,NL(1)
1 58 DO 20 J=1,NL(2)
2 59 DO 20 K=1,NL(3)
3 60 DO 20 L=1,NL(4)
4 61 DO 20 M=1,NREP
5 62 20 SUM=SUM+BRES(I,J,K,L,M)**2
63 SST=SUM-CC
64 WRITE (10,250) SUM, SST
65 250 FORMAT(1H0,2X,'SUM=',F20.10,5X,'SST=',F20.10)
66 C
67 C CALCULATE THE TREATMENT SUMS OF SQUARES, SSTR
68 C
69 SUM=0.0
70 DO 30 I=1,NL(1)
1 71 DO 30 J=1,NL(2)
2 72 DO 30 K=1,NL(3)
3 73 DO 30 L=1,NL(4)
4 74 S1=0.0
4 75 DO 25 M=1,NREP
5 76 25 S1=S1+BRES(I,J,K,L,M)
4 77 S1=S1**2
4 78 30 SUM=SUM+S1
79 SSTR=SUM/NREP-CC
80 WRITE (10,260) SUM, SSTR
81 260 FORMAT(1H0,2X,'SUM=',F20.10,5X,'SSTR=',F20.10)
82 C
83 C
84 C CALCULATE REPLICATE SUMS OF SQUARES, SSR
85 SUM=0.0
86 DO 40 M=1,NREP
1 87 S1=0.0
1 88 DO 35 I=1,NL(1)
2 89 DO 35 J=1,NL(2)
3 90 DO 35 K=1,NL(3)
4 91 DO 35 L=1,NL(4)
5 92 35 S1=S1+BRES(I,J,K,L,M)
1 93 S1=S1**2
1 94 40 SUM=SUM+S1
95 SSR=SUM/(NL(1)*NL(2)*NL(3)*NL(4))-CC
96 WRITE (10,270) SUM, SSR
97 270 FORMAT(1H0,2X,'SUM=',F20.10,5X,'SSR=',F20.10)
98 C
99 C CALCULATE ERROR SUM OF SQUARES, SSE
100 C
101 SSE=SST-SSTR-SSR
102 WRITE (10,280)SSE
103 280 FORMAT(1H0,2X,'SSE=',F20.10)
104 C
105 C CALCULATE MAIN EFFECTS OF FACTOR 1,SS1
106 C
```

```
Line# 1      7
107      SUM=0.0
108      DO 50 I=1,NL(1)
109      S1=0.0
110      DO 45 J=1,NL(2)
111      DO 45 K=1,NL(3)
112      DO 45 L=1,NL(4)
113      DO 45 M=1,NREP
114 45     S1=S1+BRES(I,J,K,L,M)
115      S1=S1**2
116 50     SUM=SUM+S1
117      SS1=SUM/(NL(2)*NL(3)*NL(4)*NREP)-CC
118      WRITE (10,290) SUM, SS1
119 290    FORMAT(1H0,2X,'SUM=',F20.10,5X,'SS1=',F20.10)
120 C
121 C      CALCULATE MAIN EFFECTS OF FACTOR 2,SS2
122 C
123      SUM=0.0
124      DO 60 J=1,NL(2)
125      S1=0.0
126      DO 55 I=1,NL(1)
127      DO 55 K=1,NL(2)
128      DO 55 L=1,NL(3)
129      DO 55 M=1,NREP
130 55     S1=S1+BRES(I,J,K,L,M)
131      S1=S1**2
132 60     SUM=SUM+S1
133      SS2=SUM/(NL(1)*NL(3)*NL(4)*NREP)-CC
134      WRITE (10,300) SUM, SS2
135 300    FORMAT(1H0,2X,'SUM=',F20.10,5X,'SS2=',F20.10)
136      IF (NF.LE.2) GO TO 81
137 C
138 C      CALCULATE MAIN EFFECTS OF FACTOR 3, SS3
139 C
140      SUM=0.0
141      DO 70 K=1,NL(3)
142      S1=0.0
143      DO 65 I=1,NL(1)
144      DO 65 J=1,NL(2)
145      DO 65 L=1,NL(4)
146      DO 65 M=1,NREP
147 65     S1=S1+BRES(I,J,K,L,M)
148      S1=S1**2
149 70     SUM=SUM+S1
150      SS3=SUM/(NL(1)*NL(2)*NL(4)*NREP)-CC
151      WRITE (10,310) SUM, SS3
152 310    FORMAT(1H0,2X,'SUM=',F20.10,5X,'SS3=',F20.10)
153      IF(NF.LE.3) GO TO 81
154 C
155 C      CALCULATE MAIN EFFECTS OF FACTOR 4, SS4
156 C
157      SUM=0.0
158      DO 80 L=1,NL(4)
159      S1=0.0
```

```
D Line# I      7
1 160          DO 75 I=1,NL(1)
2 161          DO 75 J=1,NL(2)
3 162          DO 75 K=1,NL(3)
4 163          DO 75 M=1,NREP
5 164 75      S1=S1+BRES(I,J,K,L,M)
1 165          S1=S1*S2
1 166 80      SUM=SUM+S1
167          SS4=SUM/(NL(1)*NL(2)*NL(3)*NREP)-CC
168          WRITE (10,320) SUM, SS4
169 320      FORMAT(1H0,2X,'SUM=',F20.10,5X,'SS4=',F20.10)
170 C
171 C      CALCULATE TWO WAY FACTOR INTERACTION EFFECT, SS12
172 C
173 81      SUM=0.0
174          DO 90 I=1,NL(1)
2 175          DO 90 J=1,NL(2)
2 176          S1=0.0
2 177          DO 85 K=1,NL(3)
3 178          DO 85 L=1,NL(4)
4 179          DO 85 M=1,NREP
5 180 85      S1=S1+BRES(I,J,K,L,M)
2 181          S1=S1**2
2 182 90      SUM=SUM+S1
183          SUM=SUM/(NL(3)*NL(4)*NREP)-CC
184          SS12=SUM-SS1-SS2
185          WRITE (10,330) SUM, SS12
186 330      FORMAT(1H0,2X,'SUM=',F20.10,5X,'SS12=',F20.10)
187 C
188          IF(NF.LE.2) GO TO 200
189 C
190 C      CALCULATE TWO WAY FACTOR INTERACTION EFFECT, SS13
191 C
192          SUM=0.0
193          DO 100 I=1,NL(1)
1 194          DO 100 K=1,NL(3)
2 195          S1=0.0
2 196          DO 95 J=1,NL(2)
3 197          DO 95 L=1,NL(4)
4 198          DO 95 M=1,NREP
5 199 95      S1=S1+BRES(I,J,K,L,M)
2 200          S1=S1**2
2 201 100     SUM=SUM+S1
202          SUM=SUM/(NL(2)*NL(4)*NREP)-CC
203          SS13=SUM-SS1-SS3
204          WRITE (10,340) SUM, SS13
205 340      FORMAT(1H0,2X,'SUM=',F20.10,5X,'SS13=',F20.10)
206 C
207 C      CALCULATE TWO WAY FACTOR EFFECT, SS23
208 C
209          SUM=0.0
210          DO 110 J=1,NL(2)
1 211          DO 110 K=1,NL(3)
2 212          S1=0.0
```

```
Line# 1 7
213 DO 105 I=1,NL(1)
214 DO 105 L=1,NL(4)
215 DO 105 M=1,NREP
216 105 S1=S1+BRES(I,J,K,L,M)
217 S1=S1**2
218 110 SUM=SUM+S1
219 SUM=SUM/(NL(1)*NL(4)*NREP)-CC
220 SS23=SUM-SS2-SS3
221 WRITE (10,350) SUM, SS23
222 350 FORMAT(1H0,2X,'SUM=',F20.10,5X,'SS23=',F20.10)
223 C
224 IF (NF.LE.3) GO TO 144
225 C
226 C CALCULATE TWO WAY FACTOR INTERACTION EFFECT, SS14
227 C
228 SUM=0.0
229 DO 120 I=1,NL(1)
230 DO 120 L=1,NL(4)
231 S1=0.0
232 DO 115 J=1,NL(2)
233 DO 115 K=1,NL(3)
234 DO 115 M=1,NREP
235 115 S1=S1+BRES(I,J,K,L,M)
236 S1=S1**2
237 120 SUM=SUM+S1
238 SUM=SUM/(NL(2)*NL(3)*NREP)-CC
239 SS14=SUM-SS1-SS4
240 WRITE (10,360) SUM, SS14
241 360 FORMAT(1H0,2X,'SUM=',F20.10,5X,'SS14=',F20.10)
242 C
243 C CALCULATE TWO WAY FACTOR EFFECT, SS24
244 C
245 SUM=0.0
246 DO 130 J=1,NL(2)
247 DO 130 L=1,NL(4)
248 S1=0.0
249 DO 125 I=1,NL(1)
250 DO 125 K=1,NL(3)
251 DO 125 M=1,NREP
252 125 S1=S1+BRES(I,J,K,L,M)
253 S1=S1**2
254 130 SUM=SUM+S1
255 SUM=SUM/(NL(1)*NL(3)*NREP)-CC
256 SS24=SUM-SS2-SS4
257 WRITE (10,370) SUM, SS24
258 370 FORMAT(1H0,2X,'SUM=',F20.10,5X,'SS24=',F20.10)
259 C
260 C CALCULATE TWO WAY FACTOR EFFECT, SS34
261 C
262 SUM=0.0
263 DO 140 K=1,NL(3)
264 DO 140 L=1,NL(4)
265 S1=0.0
```

```
D Line# I      7
2 266      DO 135 I=1,NL(1)
3 267      DO 135 J=1,NL(2)
4 268      DO 135 M=1,NREP
5 269 135   S1=S1+BRES(I,J,K,L,M)
2 270      S1=S1**2
2 271 140   SUM=SUM+S1
      272   SUM=SUM/(NL(1)*NL(2)*NREP)-CC
      273   SS34=SUM-SS3-SS4
      274   WRITE (10,380) SUM, SS34
      275 380   FORMAT(1H0,2X,'SUM=',F20.10,5X,'SS34=',F20.10)
      276 C
      277 C    CALCULATE THREE WAY INTERACTION EFFECT, SS123
      278 C
      279 144   SUM=0.0
      280 C
      281      DO 150 I=1,NL(1)
1 282      DO 150 J=1,NL(2)
2 283      DO 150 K=1,NL(3)
3 284      S1=0.0
3 285      DO 145 L=1,NL(4)
4 286      DO 145 M=1,NREP
5 287 145   S1=S1+BRES(I,J,K,L,M)
3 288      S1=S1**2
3 289 150   SUM=SUM+S1
      290   SUM=SUM/(NL(4)*NREP)-CC
      291   SS123=SUM-SS1-SS2-SS3-SS12-SS13-SS23
      292   WRITE (10,390) SUM, SS123
      293 390   FORMAT(1H0,2X,'SUM=',F20.10,5X,'SS123=',F20.10)
      294 C
      295      IF (NF.LE.3) GO TO 200
      296 C
      297 C    CALCULATE THREE WAY INTERACTION EFFECT, SS124
      298 C
      299      SUM=0.0
      300      DO 160 I=1,NL(1)
1 301      DO 160 J=1,NL(2)
2 302      DO 160 L=1,NL(4)
3 303      S1=0.0
3 304      DO 155 K=1,NL(3)
4 305      DO 155 M=1,NREP
5 306 155   S1=S1+BRES(I,J,K,L,M)
3 307      S1=S1**2
3 308 160   SUM=SUM+S1
      309   SUM=SUM/(NL(3)*NREP)-CC
      310   SS124=SUM-SS1-SS2-SS4-SS12-SS14-SS24
      311   WRITE (10,400) SUM, SS124
      312 400   FORMAT(1H0,2X,'SUM=',F20.10,5X,'SS124=',F20.10)
      313 C
      314 C    CALCULATE THREE WAY INTERACTION EFFECT, SS234
      315 C
      316      SUM=0.0
      317      DO 170 J=1,NL(2)
1 318      DO 170 K=1,NL(3)
```

```

D Line# 1      7
2 319         DO 170 L=1,NL(4)
3 320         S1=0.0
3 321         DO 165 I=1,NL(1)
4 322         DO 165 M=1,NREP
5 323 165     S1=S1+BRES(I,J,K,L,M)
3 324         S1=S1**2
3 325 170     SUM=SUM+S1
326         SUM=SUM/(NL(1)*NREP)-CC
327         SS234=SUM-SS2-SS3-SS4-SS23-SS24-SS34
328         WRITE (10,410) SUM, SS234
329 410     FORMAT(1H0,2X,'SUM=',F20.10,5X,'SS234=',F20.10)
330 C
331 C         CALCULATE THREE WAY INTERACTION EFFECT, SS134
332 C
333         SUM=0.0
334         DO 180 I=1,NL(1)
1 335         DO 180 K=1,NL(3)
2 336         DO 180 L=1,NL(4)
3 337         S1=0.0
3 338         DO 175 J=1,NL(2)
4 339         DO 175 M=1,NREP
5 340 175     S1=S1+BRES(I,J,K,L,M)
3 341         S1=S1**2
3 342 180     SUM=SUM+S1
343         SUM=SUM/(NL(2)*NREP)-CC
344         SS134=SUM-SS1-SS3-SS4-SS13-SS14-SS34
345         WRITE (10,420) SUM, SS134
346 420     FORMAT(1H0,2X,'SUM=',F20.10,5X,'SS134=',F20.10)
347 C
348 C         CALCULATE FOUR WAY INTERACTION, SS1234
349 C
350         SS1234=SSR-SS1-SS2-SS3-SS4-SS12-SS13-SS14-SS23-SS24-SS34-SS123-SS1
351 #24-SS234-SS134
352         WRITE (10,430) SS1234
353 430     FORMAT(1H0,2X,'SS1234=',F20.10)
354         CLOSE (10)
355 C
356 C         COMPLETE THE ANALYSIS OF VARIANCE TABLE
357 C
358 200     TABLE(1,1)=(NREP-1)*1.0
359         TABLE(2,1)=(NL(1)-1)*1.0
360         TABLE(3,1)=(NL(2)-1)*1.0
361         TABLE(4,1)=(NL(3)-1)*1.0
362         TABLE(5,1)=(NL(4)-1)*1.0
363         TABLE(6,1)=(NL(1)-1)*(NL(2)-1)*1.0
364         TABLE(7,1)=(NL(1)-1)*(NL(3)-1)*1.0
365         TABLE(8,1)=(NL(1)-1)*(NL(4)-1)*1.0
366         TABLE(9,1)=(NL(2)-1)*(NL(3)-1)*1.0
367         TABLE(10,1)=(NL(2)-1)*(NL(4)-1)*1.0
368         TABLE(11,1)=(NL(3)-1)*(NL(4)-1)*1.0
369         TABLE(12,1)=(NL(1)-1)*(NL(2)-1)*(NL(3)-1)*1.0
370         TABLE(13,1)=(NL(1)-1)*(NL(2)-1)*(NL(4)-1)*1.0
371         TABLE(14,1)=(NL(1)-1)*(NL(3)-1)*(NL(4)-1)*1.0

```

```

D Line# 1      7      Microsoft FORTRAN77 V3.20 02/0
372      TABLE(15,1)=(NL(2)-1)*(NL(3)-1)*(NL(4)-1)*1.0
373      TABLE(16,1)=(NL(1)-1)*(NL(2)-1)*(NL(3)-1)*(NL(4)-1)*1.0
374      TABLE(17,1)=(NL(1)*NL(2)*NL(3)*NL(4)-1)*(NREF-1)*1.0
375      TABLE(1,2)=SSR
376      TABLE(2,2)=SS1
377      TABLE(3,2)=SS2
378      TABLE(4,2)=SS3
379      TABLE(5,2)=SS4
380      TABLE(6,2)=SS12
381      TABLE(7,2)=SS13
382      TABLE(8,2)=SS14
383      TABLE(9,2)=SS23
384      TABLE(10,2)=SS24
385      TABLE(11,2)=SS34
386      TABLE(12,2)=SS123
387      TABLE(13,2)=SS124
388      TABLE(14,2)=SS134
389      TABLE(15,2)=SS234
390      TABLE(16,2)=SS1234
391      TABLE(17,2)=SSE
392      DO 205 I=1,17
1 393      IF (TABLE(I,1).EQ.0.0) GO TO 205
1 394      TABLE(I,3)=TABLE(I,2)/TABLE(I,1)
1 395 205    CONTINUE
396      IF (TABLE(17,3).EQ.0.0) THEN
397      WRITE(*,1000)
398      GOTO 220
399      ENDIF
400      DO 210 I=1,17
1 401      TABLE(I,4)=TABLE(I,3)/TABLE(17,3)
1 402 210    CONTINUE
403 C
404 C      STORE RESULTS ON DATA FILE, 101.
405 C
406 C      REWIND 101
407 C      WRITE(101,*) IANA,NDPRES,BRES, TABLE
408 C      CLOSE(101,STATUS='KEEP')
409 220    CONTINUE
410 C
411 C      RETURN TO MAIN MENU
412 C
413 C      RETURN
414 C
415 C      FORMAT STATEMENTS
416 C
417 1000    FORMAT(1H0,10X,'*** DATA ERROR IN SUBROUTINE STAT ***'/1H ,10X,
418 #BLE ARRAY ELEMENT 17,3 EQUAL TO ZERO')
419      END

```

Name	Type	Offset	P	Class
BRES	REAL	36	*	
CC	REAL	96		

D Line#	l	7	
I	INTEGER*4		100
IANA	INTEGER*4		16
J	INTEGER*4		104
J5	INTEGER*4		16 *
J6	INTEGER*4		20 *
J7	INTEGER*4		24 *
J8	INTEGER*4		28 *
K	INTEGER*4		120
L	INTEGER*4		128
M	INTEGER*4		136
MNL	INTEGER*4		4 *
NDFRES	INTEGER*4		32 *
NF	INTEGER*4		0 *
NL	INTEGER*4		8 *
NREP	INTEGER*4		12 *
S1	REAL		240
S2	REAL		668
SS1	REAL		32
SS12	REAL		48
SS123	REAL		72
SS1234	REAL		88
SS124	REAL		76
SS13	REAL		52
SS134	REAL		84
SS14	REAL		56
SS2	REAL		36
SS23	REAL		60
SS234	REAL		80
SS24	REAL		64
SS3	REAL		40
SS34	REAL		68
SS4	REAL		44
SSE	REAL		92
SSR	REAL		28
SST	REAL		20
SSTR	REAL		24
SUM	REAL		108
TABLE	REAL		40 *

Name	Type	Size	Class
TAT			SUBROUTINE

Pass One No Errors Detected
419 Source Lines

```
D Line# 1      7
1  $PAGESIZE:60
2  $LARGE
3  $DEBUG
4  C           ***** SUBROUTINE PRTRES *****
5  C
6      SUBROUTINE PRTRES(NF,MNL,NL,NREP,J5,J6,J7,J8,NDPRES,BRES,TABLE,IDR
7      #,NDSPR,FACLEV,NFAC)
8  C
9  C      TYPE AND DIMENSION STATEMENTS
10 C
11      CHARACTER*40 FDES(7)
12      DIMENSION NL(4),BRES(4,4,4,4,4),TABLE(17,4),NDPRES(4,4,4,4,4),IDR
13      #4,30),FACLEV(4,4,2),NFAC(4)
14 C
15 C      READ FILES 100 AND 101
16 C
17      OPEN(100,FILE='B:STAT.SET',STATUS='OLD')
18      OPEN(101,FILE='B:RES.RES',STATUS='OLD')
19      REWIND 100
20      READ(100,*)NREP,NDSPR,NF,MNL,NFAC,IDR,NL,FACLEV
21      REWIND 101
22      READ(101,*)IANA,NDPRES,BRES,TABLE
23      CLOSE(100,STATUS='KEEP')
24      CLOSE(101,STATUS='KEEP')
25 C
26 C      NAME THE FACTORS
27 C
28      FDES(1)='CID ANALOG SIGNAL CUTTING BAND'
29      FDES(2)='DEPTH OF CUT INTO ROCK'
30      FDES(3)='ERROR, NOT USED'
31      FDES(4)='ERROR, NOT USED'
32      FDES(5)='COAL/ROCK HARDNESS RATIO'
33      FDES(6)='SHEARER VELOCITY'
34      FDES(7)='SHEARER TYPE'
35 C
36 C      OUTPUT RESULTS TO PRINT FILE 10
37 C
38 C      A. EXPERIMENTAL REPLICATIONS
39 C
40      OPEN(10,FILE='LPT1',STATUS='NEW')
41      WRITE(10,1000)
42      WRITE(10,1010)
43      DO 300 I=1,NREP
1  44      WRITE(10,1020)I
1  45      DO 300 J=1,NDSPR
2  46      WRITE(10,1030)J,IDR(I,J)-101
2  47 300 CONTINUE
48 C
49 C      B. EXPERIMENTAL FACTORS AND FACTOR LEVELS
50 C
51      WRITE(10,1040)
52      DO 400 I=1,NF
1  53      WRITE(10,1050)I,FDES(NFAC(I))
```

```

D Line# 1      7
1      54      DO 400 J=1,MNL
2      55      WRITE(10,1060)J,FACLEV(I,J,1),FACLEV(I,J,2)
2      56 400    CONTINUE
          57 C
          58 C      C. BASE RESULTS
          59 C
          60      WRITE(10,1070) IANA
          61      WRITE(10,1080)
          62      WRITE(10,1090)
          63      DO 500 I=1,NL(1)
1      64      DO 500 J=1,NL(2)
2      65      DO 500 K=1,NL(3)
3      66      DO 500 L=1,NL(4)
4      67 500    WRITE(10,1100) I,J,K,L,BRES(I,J,K,L,1),BRES(I,J,K,L,2),BRES(I,J,K,
4      68      #L,3),BRES(I,J,K,L,4)
          69 C
          70 C      D. TOTAL NUMBER OF DATA POINTS
          71 C
          72      WRITE(10,1075) IANA
          73      WRITE(10,1080)
          74      WRITE(10,1090)
          75      DO 600 I=1,NL(1)
1      76      DO 600 J=1,NL(2)
2      77      DO 600 K=1,NL(3)
3      78      DO 600 L=1,NL(4)
4      79 600    WRITE(10,1105) I,J,K,L,NDPRES(I,J,K,L,1),NDPRES(I,J,K,L,2),NDPRES(I
4      80      #,J,K,L,3),NDPRES(I,J,K,L,4)
          81 C
          82 C      E. STATISTICAL TABLE
          83 C
          84      WRITE(10,1110)
          85      WRITE(10,1120)
          86      WRITE(10,1130)
          87      WRITE(10,1140)
          88      WRITE(10,1150) TABLE(1,1),TABLE(1,2),TABLE(1,3),TABLE(1,4)
          89      WRITE(10,1160)
          90      WRITE(10,1170) TABLE(2,1),TABLE(2,2),TABLE(2,3),TABLE(2,4)
          91      WRITE(10,1180) TABLE(3,1),TABLE(3,2),TABLE(3,3),TABLE(3,4)
          92      WRITE(10,1190) TABLE(4,1),TABLE(4,2),TABLE(4,3),TABLE(4,4)
          93      WRITE(10,1200) TABLE(5,1),TABLE(5,2),TABLE(5,3),TABLE(5,4)
          94      WRITE(10,1210)
          95      WRITE(10,1220)
          96      WRITE(10,1230) TABLE(6,1),TABLE(6,2),TABLE(6,3),TABLE(6,4)
          97      WRITE(10,1240) TABLE(7,1),TABLE(7,2),TABLE(7,3),TABLE(7,4)
          98      WRITE(10,1250) TABLE(8,1),TABLE(8,2),TABLE(8,3),TABLE(8,4)
          99      WRITE(10,1260) TABLE(9,1),TABLE(9,2),TABLE(9,3),TABLE(9,4)
100     WRITE(10,1270) TABLE(10,1),TABLE(10,2),TABLE(10,3),TABLE(10,4)
101     WRITE(10,1280) TABLE(11,1),TABLE(11,2),TABLE(11,3),TABLE(11,4)
102     WRITE(10,1290)
103     WRITE(10,1300)
104     WRITE(10,1310) TABLE(12,1),TABLE(12,2),TABLE(12,3),TABLE(12,4)
105     WRITE(10,1320) TABLE(13,1),TABLE(13,2),TABLE(13,3),TABLE(13,4)
106     WRITE(10,1330) TABLE(14,1),TABLE(14,2),TABLE(14,3),TABLE(14,4)

```

```

D Line# 1 7
107 WRITE(10,1340) TABLE(15,1), TABLE(15,2), TABLE(15,3), TABLE(15,4)
108 WRITE(10,1350)
109 WRITE(10,1360)
110 WRITE(10,1370) TABLE(16,1), TABLE(16,2), TABLE(16,3), TABLE(16,4)
111 WRITE(10,1380) TABLE(17,1), TABLE(17,2), TABLE(17,3), TABLE(17,4)
112 CLOSE(10)
113 C
114 C FORMAT STATEMENTS
115 C
116 1000 FORMAT('1',24X,'CID EVALUATION PROGRAM RESULTS'/1H ,24X,'-----
117 #-----')
118 1010 FORMAT(1H0,6X,'A. EXPERIMENT REPLICATIONS')
119 1020 FORMAT(1H0,10X,'REPLICATION NUMBER',2X,I1)
120 1030 FORMAT(1H ,13X,'DATA SET',1X,I2,'.',1X,I3)
121 1040 FORMAT(1H0/1H ,6X,'B. EXPERIMENTAL FACTORS AND FACTOR LEVELS')
122 1050 FORMAT(1H0,10X,'FACTOR NUMBER',1X,I2,'.',2X,A)
123 1060 FORMAT(1H ,13X,'LEVEL',1X,I2,'.',1X,G10.3,1X,'.',1X,G10.3)
124 1070 FORMAT(1H1 ,6X,'C. BASE RESULTS : RUN SELECTION NUMBER',1X,I2)
125 1075 FORMAT(1H1,6X,'D. TOTAL DATA POINTS : RUN SELECTION NUMBER',1X,I2)
126 1080 FORMAT(1H0,1X,'ARRAY INDEX',3X,'REP1.',5X,'REP2.',5X,'REP3.',5X,'
127 #EP4.')
128 1090 FORMAT(1H ,1X,'-----',3X,'-----',5X,'-----',5X,'-----',5X,'
129 #----')
130 1100 FORMAT(1H ,1X,I2,'.',I2,'.',I2,'.',I2,3X,F6.2,4X,F6.2,4X,F6.2,4X,
131 #6.2)
132 1105 FORMAT(1H ,1X,I2,'.',I2,'.',I2,'.',I2,3X,I6,4X,I6,4X,I6,4X,I6)
133 1110 FORMAT(1H1,6X,'E. STATISTICAL ANALYSIS')
134 1120 FORMAT(1H0,1X,'SOURCE OF',22X,'SUM OF',11X,'MEAN',14X,'F')
135 1130 FORMAT(1H ,1X,'VARIATION',7X,'D D F',10X,'SQUARES',10X,'SQUARE',1
136 #X,'FACTOR')
137 1140 FORMAT(1H ,1X,'-----',7X,'-----',10X,'-----',10X,'-----',1
138 #X,'-----')
139 1150 FORMAT(1H ,1X,'REPLICATES',6X,G10.4,6X,G10.4,6X,G10.4,6X,G10.4)
140 1160 FORMAT(1H0,1X,'MAIN EFFECTS')
141 1170 FORMAT(1H ,2X,'FACTOR 1.',6X,G10.4,6X,G10.4,6X,G10.4,6X,G10.4)
142 1180 FORMAT(1H ,9X,'2.',6X,G10.4,6X,G10.4,6X,G10.4,6X,G10.4)
143 1190 FORMAT(1H ,9X,'3.',6X,G10.4,6X,G10.4,6X,G10.4,6X,G10.4)
144 1200 FORMAT(1H ,9X,'4.',6X,G10.4,6X,G10.4,6X,G10.4,6X,G10.4)
145 1210 FORMAT(1H0,1X,'TWO FACTOR')
146 1220 FORMAT(1H ,1X,'INTERACTION')
147 1230 FORMAT(1H ,7X,'1,2.',6X,G10.4,6X,G10.4,6X,G10.4,6X,G10.4)
148 1240 FORMAT(1H ,7X,'1,3.',6X,G10.4,6X,G10.4,6X,G10.4,6X,G10.4)
149 1250 FORMAT(1H ,7X,'1,4.',6X,G10.4,6X,G10.4,6X,G10.4,6X,G10.4)
150 1260 FORMAT(1H ,7X,'2,3.',6X,G10.4,6X,G10.4,6X,G10.4,6X,G10.4)
151 1270 FORMAT(1H ,7X,'2,4.',6X,G10.4,6X,G10.4,6X,G10.4,6X,G10.4)
152 1280 FORMAT(1H ,7X,'3,4.',6X,G10.4,6X,G10.4,6X,G10.4,6X,G10.4)
153 1290 FORMAT(1H0,1X,'THREE FACTOR')
154 1300 FORMAT(1H ,1X,'INTERACTION')
155 1310 FORMAT(1H ,5X,'1,2,3.',6X,G10.4,6X,G10.4,6X,G10.4,6X,G10.4)
156 1320 FORMAT(1H ,5X,'1,2,4.',6X,G10.4,6X,G10.4,6X,G10.4,6X,G10.4)
157 1330 FORMAT(1H ,5X,'1,3,4.',6X,G10.4,6X,G10.4,6X,G10.4,6X,G10.4)
158 1340 FORMAT(1H ,5X,'2,3,4.',6X,G10.4,6X,G10.4,6X,G10.4,6X,G10.4)
159 1350 FORMAT(1H0,1X,'FOUR FACTOR')

```

```

D Line# 1      7
160 1360  FORMAT(1H ,1X, 'INTERACTION')
161 1370  FORMAT(1H ,3X, '1,2,3,4.',6X,G10.4,6X,G10.4,6X,G10.4,6X,G10.4)
162 1380  FORMAT(1H0,1X, 'ERROR',11X,G10.4,6X,G10.4,6X,G10.4,6X,G10.4)
163 C
164 C      RETURN TO MAIN PROGRAM
165 C
166      RETURN
167      END
  
```

Name	Type	Offset	P	Class
BRES	REAL	36	*	
FACLEV	REAL	52	*	
FDES	CHAR*40	0		LARGE
I	INTEGER*4	24		
IANA	INTEGER*4	20		
IDR	INTEGER*4	44	*	
J	INTEGER*4	32		
J5	INTEGER*4	16	*	
J6	INTEGER*4	20	*	
J7	INTEGER*4	24	*	
J8	INTEGER*4	28	*	
K	INTEGER*4	56		
L	INTEGER*4	64		
MNL	INTEGER*4	4	*	
NDPRES	INTEGER*4	32	*	
NDSFR	INTEGER*4	48	*	
NF	INTEGER*4	0	*	
NFAC	INTEGER*4	56	*	
NL	INTEGER*4	8	*	
NREF	INTEGER*4	12	*	
TABLE	REAL	40	*	

Name	Type	Size	Class
PRTRES			SUBROUTINE

Pass One No Errors Detected
 167 Source Lines

```
D Line# 1      7
  1 #PAGESIZE:60
  2 #LARGE
  3 #DEBUG
  4 C
  5 C          ***** SUBROUTINE MANAGE *****
  6 C
  7 SUBROUTINE MANAGE(ID,S)
  8 C
  9 C TYPE AND DIMENSION STATEMENTS
10 C
11 LOGICAL O,X
12 CHARACTER FNAME*9,CH*1
13 C
14 C INQUIRE IF FILE IS OPENED (STATUS=1)
15 C
16 INQUIRE (UNIT=ID,OPENED=O)
17 IF (O) THEN
18 S=1
19 GOTO 10
20 ENDIF
21 C
22 C FILE NOT OPENED CHECK FOR EXISTENCE ON DISK
23 C
24 OPEN(1000,STATUS='NEW')
25 WRITE(1000,2000)'B:',ID,'.DAT'
26 REWIND 1000
27 READ(1000,2010)CH,FNAME
28 CLOSE (1000)
29 INQUIRE(FILE=FNAME,EXIST=X)
30 IF (X) THEN
31 C
32 C FILE EXISTS ON DISK OPEN AS OLD (STATUS=2)
33 C
34 OPEN(ID,FILE=FNAME,STATUS='OLD')
35 S=2
36 ELSE
37 C
38 C FILE DOES NOT EXIST OPEN AS NEW (STATUS=3)
39 C
40 OPEN(ID,FILE=FNAME,STATUS='NEW')
41 S=3
42 ENDIF
43 C
44 C FORMAT STATEMENTS
45 C
46 2000 FORMAT(1H ,A2,I3,A4)
47 2010 FORMAT(A1,A9)
48 10 RETURN
49 END
```

Name	Type	Offset	F	Class
CH	CHAR*1	24		

D	Line#	1	7
FNAME	CHAR*9		25
ID	INTEGER*4		0 *
D	LOGICAL*4		20
S	REAL		4 *
X	LOGICAL*4		34

Name	Type	Size	Class
MANAGE			SUBROUTINE

Pass One No Errors Detected
 49 Source Lines

```
D Line# 1      7
  1 $PAGESIZE:60
  2 $LARGE
  3 $DEBUG
  4 C
  5 C          ***** SUBROUTINE CKDATA *****
  6 C
  7 SUBROUTINE CKDATA
  8 C
  9 C TYPE AND DIMENSION STATEMENTS
 10 C
 11 CHARACTER FARRAY(898)*9,FNAME*9,CH*1,DDES*50,FDES(7)*40
 12 LOGICAL O,X
 13 DIMENSION ID(898),DATARY(8,500),NFAC(4),IDR(4,30),NL(4),FACLEV(4,
 14 #,2)
 15 C
 16 C CHECK FOR DATA OR ANALYSIS FILES ?
 17 C
 18 OPEN(6,FILE='LPT1',STATUS='NEW')
 19 WRITE(*,1000)
 20 READ(*,*)Q
 21 IF(Q.EQ.2)GOTO 2
 22 C
 23 C CHECK DISK FOR EXISTENCE OF ALL POSSIBLE DATA FILE NAMES
 24 C
 25 1 OPEN(1000,STATUS='NEW')
 26 WRITE(*,*)'INPUT TOTAL NUMBER OF FILES TO INQUIRE'
 27 READ(*,*)IFN
 28 WRITE(*,*)'INPUT STARTING NUMBER FOR SEARCH'
 29 READ(*,*)ISN
 30 DO 10 I=ISN,ISN+IFN
 1 31 ID1=I+101
 1 32 WRITE(1000,2000)'B:',ID1,'.DAT'
 1 33 REWIND 1000
 1 34 READ(1000,2010)CH,FNAME
 1 35 BACKSPACE 1000
 1 36 INQUIRE(FILE=FNAME,EXIST=X)
 1 37 IF(X)THEN
 1 38 FARRAY(I)=FNAME
 1 39 ELSE
 1 40 FARRAY(I)='N'
 1 41 ENDIF
 1 42 10 CONTINUE
 43 C
 44 C WRITE TABLE OF EXISTING DATA SET ID NUMBERS AND FILE NAMES TO
 45 C PRINTER
 46 C
 47 WRITE(6,2015)
 48 DO 20 I=ISN,ISN+IFN
 1 49 IF(FARRAY(I).EQ.'N')GOTO 20
 1 50 ID(I)=I
 1 51 WRITE(6,2020)ID(I),FARRAY(I)
 1 52 NCOUNT=NCOUNT+1
 1 53 20 CONTINUE
```

```

D Line# 1      7
54      CLOSE (1000)
55 C
56 C      PROMPT OPERATOR FOR DATA SET ID NUMBERS OF FILES WHERE DATA IS TO
57 C      BE VERIFIED
58 C
59      WRITE(*,2030)
60      READ(*,*)N
61      IF(N.EQ.1) THEN
62      NUM=NCOUNT
63      GOTO 40
64      ENDIF
65      WRITE(*,2040)
66      READ(*,*)NUM
67      DO 30 I=1,NUM
1 68      WRITE(*,2050) I
1 69      READ(*,*) ID(I)
1 70 30      CONTINUE
1 71 40      DO 50 I=1,NUM
1 72      ID(I)=ID(I)+101
1 73      CALL MANAGE(ID(I),S)
1 74      READ(ID(I), '(A)') DDES
1 75      READ(ID(I), *) IDPT, ISERER, DISSLD, CRPM, DENCOL, DENROK, (DATARY(2,J), J=
1 76      #1, IDPT), (DATARY(3,J), J=1, IDPT), (DATARY(4,J), J=1, IDPT), (DATARY(6,J)
1 77      #, J=1, IDPT), (DATARY(1,J), J=1, IDPT)
1 78      IO=INT(IDPT/30)+1
1 79      IA=1
1 80      IB=30
1 81      DO 44 K=1, IO
2 82      WRITE(6,2060) ID(I)-101
2 83      WRITE(6,2070) DDES
2 84      WRITE(6,2080) IDPT
2 85      IF(ISERER.EQ.1) WRITE(6,2090) 'JOY'
2 86      IF(ISERER.EQ.2) WRITE(6,2090) 'ANDERSON MAVOR'
2 87      IF(ISERER.EQ.3) WRITE(6,2090) 'EICKOFF 150'
2 88      IF(ISERER.EQ.4) WRITE(6,2090) 'MISUI MIKE'
2 89      WRITE(6,2100) CRPM
2 90      WRITE(6,2110) DENCOL
2 91      WRITE(6,2120) DENROK
2 92      WRITE(6,2130) DISSLD
2 93      WRITE(6,2140)
2 94      DO 45 J=IA, IB
3 95      IF(J.LE.IDPT) THEN
3 96      WRITE(6,2150) J, DATARY(2,J), DATARY(3,J), DATARY(4,J), DATARY(6,J), DAT
3 97      #ARY(1,J)
3 98      ENDIF
3 99 45      CONTINUE
2 100      IA=IA+30
2 101      IB=IB+30
2 102 44      CONTINUE
1 103      CLOSE(ID(I), STATUS='KEEP')
1 104 50      CONTINUE
105      GOTO 100
106 2      INQUIRE(UNIT=100, OPENED=0)

```

```

D Line# 1      7
107      IF(D)GOTO 60
108      INQUIRE(FILE='B:STAT.SET',EXIST=X)
109      IF(X)THEN
110      OPEN(100,FILE='B:STAT.SET',STATUS='OLD')
111      GOTO 60
112      ELSE
113      WRITE(*,1010)
114      GOTO 100
115      ENDIF
116 60      REWIND 100
117      READ(100,*)NREP,NDSPR,NF,MNL,NFAC,IDR,NL,FACLEV
118      CLOSE(100,STATUS='KEEP')
119      WRITE(6,1030)
120      WRITE(6,1035)
121      DO 65 I=1,NREP
1 122      WRITE(6,1036)I
1 123      DO 65 J=1,NDSPR
2 124      WRITE(6,1037)J,IDR(I,J)-101
2 125 65      CONTINUE
126      WRITE(6,1038)
127      FDES(1)='CID ANALOG SIGNAL CUTTING BAND'
128      FDES(2)='DEPTH OF CUT INTO ROCK'
129      FDES(3)='ERROR NOT USED'
130      FDES(4)='ERROR NOT USED'
131      FDES(5)='COAL/ROCK HARDNESS RATIO'
132      FDES(6)='SHEARER VELOCITY'
133      FDES(7)='SHEARER TYPE'
134      DO 67 I=1,NF
1 135      WRITE(6,1039)I,FDES(NFAC(I))
1 136      DO 67 J=1,MNL
2 137 67      WRITE(6,1040)J,FACLEV(I,J,1),FACLEV(I,J,2)
138 C
139 C      FORMAT STATEMENTS
140 C
141 1000      FORMAT(1H0,10X,'CHECK DATA FILE OR ANALYSIS FILE ? (INPUT 1 FOR D
142      #TA FILE OR 2 FOR ANALYSIS FILE)')
143 1010      FORMAT(1H0,10X,'DATA ANALYSIS FILE DOES NOT EXIST ON DISK')
144 1030      FORMAT(1H1,29X,'CURRENT ANALYSIS SETUP'/1H0,29X,'-----
145      #-----')
146 1035      FORMAT(1H0,6X,'A. EXPERIMENT REPLICATIONS')
147 1036      FORMAT(1H0,10X,'REPLICATION NUMBER',2X,I1)
148 1037      FORMAT(1H ,13X,'DATA SET',1X,I2,'.',1X,I3)
149 1038      FORMAT(1H0/1H ,6X,'B. EXPERIMENTAL FACTORS AND FACTOR LEVELS')
150 1039      FORMAT(1H0,10X,'FACTOR NUMBER',1X,I2,'.',2X,A)
151 1040      FORMAT(1H ,13X,'LEVEL',1X,I2,'.',1X,6I0.3,1X,',',1X,6I0.3)
152 2000      FORMAT(1H ,A2,I3,A4)
153 2010      FORMAT(A1,A9)
154 2015      FORMAT(1H1,3X,'TABLE OF EXISTING DATA SET ID NUMBERS AND FILENAME
155      # ON DISK'/1H0,10X,'DATA SET ID NUMBER',10X,'FILE NAME'/11X,'-----
156      #-----',10X,'-----')
157 2020      FORMAT(1H+,17X,I3,20X,A/)
158 2030      FORMAT(1H0,10X,'DO YOU WANT A PRINTOUT OF ALL OR SOME OF THE DAT
159      #FILES ? (INPUT 1 FOR ALL, OR 2 FOR SOME)')

```

D Line#	1	7			
ISERER	INTEGER*4		140		
ISN	INTEGER*4		28		
J	INTEGER*4		160		
K	INTEGER*4		196		
MNL	INTEGER*4		224		
N	INTEGER*4		66		
NCOUNT	INTEGER*4		62		
NDSPR	INTEGER*4		216		
NF	INTEGER*4		220		
NFAC	INTEGER*4	3592		LARGE	
NL	INTEGER*4	3608		LARGE	
NREP	INTEGER*4		212		
NUM	INTEGER*4		70		
O	LOGICAL*4		208		
Q	REAL		20		
S	REAL		82		
X	LOGICAL*4		54		

Name	Type	Size	Class
CKDATA			SUBROUTINE
MANAGE			SUBROUTINE

Pass One No Errors Detected
 188 Source Lines

APPENDIX F

RESULTS OF INITIAL CID EVALUATION PROCEDURE

Test #1 - Modulation Amplitude to Analog Output Proportionality

The coal interface detector is designed to output a voltage that is proportional to the amplitude modulations of the vibration signal input. A signal consisting of a 3000 Hz sine wave carrier frequency modulated by a 10 Hz sine wave was used as an input to the CID. The analog output of the CID was measured as a function of the modulation amplitude. The rms level of the signal was kept constant. This test was considered successful if the analog output increased as the modulation amplitude was increased.

Test #2 - Bandpass Filter

In an attempt to increase the discriminant signal to noise ratio, the vibration input is bandpass filtered. The operation of this bandpass filter was checked by varying a constant amplitude sine wave carrier frequency over the range of 300 to 30,000 Hz. The modulation frequency was maintained at 20 Hz and at a constant amplitude. The test was considered successful if the maximum analog output of the CID occurred in the 2000 to 4000 Hz band.

Test #3 - Automatic Gain Control

The automatic gain control should maintain the analog output at a constant level if only the magnitude and not the character of the vibration signal is changed. A signal consisting of a 3000 Hz sine wave modulated by a 10 Hz sine wave was fed to the CID. The steady state CID analog output was recorded as a function of the gain applied to the signal level. The test was considered successful if the analog output remained within 20% over a gain range of 1 to 4.

Test #4 - Idle Level Switch

The idle level switch uses the average level of the vibration signal input to distinguish between the cutting and idling conditions. The vibration level at which the idle light goes off and the analog signal comparator is enabled can be varied by a switch setting. In Test #4, the procedure described in Test #3 was repeated. At each gain setting, the idle switch was advanced until the idle light turned on. The test was considered successful when increased input levels also increased the idle switch setting required to cause the idle light to switch on.

Test #5 - Rock Indicator Switches

Rock cutting is indicated by the CID when the analog signal exceeds a high level set point or drops below a low level set point. Both set points are switch adjustable. In Test #5, the procedure described in Test #1 was repeated. After each increase in amplitude modulation of the input signal, the high level set switch setting was advanced from zero until the rock light went off. This was conducted with the low level switch set at zero.

Then, the low level switch was advanced from zero until the rock light came on.

The test was considered successful when an increase in modulation level required an increase in the high and low level rock switch settings to cause the expected change in the rock light state.

TEST RESULTS

I. Serial number 72-0003-01

o Test #1 - Modulation amplitude to analog output proportionality

<u>Input Signal Modulation* (mv)</u>	<u>Input Signal rms (mv)</u>	<u>Analog Output Signal (v)</u>
0	15	0.01
2	15.5	0.92
4	15.9	1.70
6	16.2	3.0
8	16.3	3.9
10	16	4.5
12	15.1	5.1
14	12.6	5.8

*The input modulation measure is the peak voltage change from the carrier signal peak.

o Test #2 - Bandpass filter

<u>Carrier Frequency (Hz)</u>	<u>Input Signal rms (mv)</u>	<u>Analog Output Signal (v)</u>
300	5.6	0.50
1000	11.6	0.74
2000	12.6	5.9
3000	12.5	5.7
4000	12.8	6.0
5000	12.8	5.7
6000	12.8	5.4
7000	12.9	3.2
8000	12.9	1.8
10000	12.9	0.67
30000	12.9	0.09

o Test #3 - Automatic gain control

<u>Input Signal rms (mv)</u>	<u>Analog Output Signal (v)</u>
8	5.7
10	5.4
12	5.3
16	5.8
32	4.8
80	3.1

o Test #4 - Idle level switch

<u>Input Signal rms (mv)</u>	<u>Switch Setting at Idle Indication</u>
8	2
10	2.8
12	3.1
16	4.1
32	4.5
80	4.5

o Test #5 - Rock indicator switches

<u>Analog Signal Output (v)</u>	<u>Low Level Switch</u>	<u>High Level Switch</u>
0.5	1	1
1.5	2	2
3.0	3	3
4.5	4	4
6.0	4.5	5

Note: Once the high level switch is activated at levels above switch setting 5, the rock light sometimes "sticks" in the on position.

II. Serial number 72-0003-02

- o Test #1 - Modulation amplitude to analog output proportionality

<u>Input Signal Modulation (mv)</u>	<u>Input Signal rms (mv)</u>	<u>Analog Output Signal (v)</u>
0	14.5	0.020
2	14.9	1.65
4	15.3	3.20
8	18.3	5.82
12	17.4	7.09
14	14.0	7.8

- o Test #2 - Bandpass filter

<u>Carrier Frequency (Hz)</u>	<u>Input Signal rms (mv)</u>	<u>Analog Output Signal (v)</u>
300	5.6	0.76
1000	12.8	0.45
2000	14.1	8.5
3000	14.0	7.8
4000	14.3	7.3
5000	14.4	8.3
6000	14.3	7.3
7000	14.4	4.7
8000	14.4	2.2
10000	14.4	0.41
30000	14.4	0.015

- o Test #3 - Automatic gain control

<u>Input Signal rms (mv)</u>	<u>Analog Output Signal (v)</u>
8	7.6
10	7.7
12	7.8
16	8.0
32	8.1
80	6.9

o Test #4 - Idle level switch

<u>Input Signal rms (mv)</u>	<u>Switch Setting at Idle Indication</u>
8	2
10	2.3
20	4.5
40	5.0
60	5.0
80	5.0

o Test #5 - Rock indicator switches

<u>Analogue Signal Output (v)</u>	<u>Low Level Switch</u>	<u>High Level Switch</u>
1.0	1.0	1.0
1.5	1.5	1.5
3.0	2.25	2.25
4.0	2.75	2.75
5.0	3.25	3.25
6.5	3.75	3.75
7.5	4.25	4.25

III. Serial number 72-0003-03

This CID did not function. The "on" light indicated the unit to be on, but all other functions of the CID were inoperable. The cause of this failure has not been investigated.

IV. Serial number 72-0003-04

- o Test #1 - Modulation amplitude to analog output proportionality

<u>Input Signal Modulation (mv)</u>	<u>Input Signal rms (mv)</u>	<u>Analog Output Signal (v)</u>
0	15	0.025
2	15.6	1.97
4	15.9	4.13
8	16.3	6.23
12	15.0	7.17
14	12.6	7.3

- o Test #2 - Bandpass filter

<u>Carrier Frequency (Hz)</u>	<u>Input Signal rms (mv)</u>	<u>Analog Output Signal (v)</u>
1000	11.6	0.03
2000	12.6	6.3
3000	12.6	7.3
4000	12.8	6.1
5000	12.9	7.2
6000	12.9	6.6
7000	12.9	2.6
8000	12.9	0.83
10000	12.9	0.17
30000	12.9	0.00

- o Test #3 - Automatic gain control

<u>Input Signal rms (mv)</u>	<u>Analog Output Signal (v)</u>
8	6.8
10	6.8
12	7.0
16	7.0
32	6.3
80	1.1

o Test #4 - Idle level switch

<u>Input Signal rms (mv)</u>	<u>Switch Setting at Idle Indication</u>
8	1.5
10	2.0
20	4.0
40	5.0
60	5.0
80	5.0

o Test #5 - Rock indicator switches

<u>Analog Signal Output (v)</u>	<u>Low Level Switch</u>	<u>High Level Switch</u>
1.0	1.0	1.0
2.0	2.0	2.0
3.0	2.0	2.0
4.0	2.75	2.75
5.0	3.25	3.25
6.0	4.0	4.0
7.0	4.5	4.5

APPENDIX G

**EXAMPLE OF THE COMPUTATIONAL PROCEDURE
USED FOR FACTORIAL EXPERIMENTATION**

This Appendix is included as an aid in understanding the Analytical Methods used for Factorial Experimentation. Included is an example of a Factorial Experiment that was conducted on two sample sets of data.

The experiment consists of two replicates. There is one data set associated with each replicate. The factors involved in this experiment are the analog signal(A), depth-of-cut into rock(B) , and the coal/rock hardness ratio(C). The levels assigned to each of these factors are:

$$0.1 \leq A1 \leq 1.0$$

$$1.0 \leq A2 \leq 5.0$$

$$5.0 \leq A3 \leq 10.0$$

$$0.0 \leq B1 \leq 1.0$$

$$1.0 \leq B2 \leq 8.0$$

$$8.0 \leq B3 \leq 60.0$$

$$0.10 \leq C1 \leq 0.25$$

$$0.25 \leq C2 \leq 0.75$$

$$0.75 \leq C3 \leq 1.00$$

To illustrate the analysis of a three factor experiment suppose that the two replicates yielded the following percentages of occurrences:

Table of Results

Factorial Condition	REP1	REP2
1111	0	0
1121	0	0
1131	0	0
1211	25	100
1221	0	15.38
1231	0	60
1311	0	0
1321	0	0
1331	0	0
2111	0	0
2121	100	0
2131	0	0
2211	50	0
2221	100	76.92
2231	0	40
2311	0	0
2321	100	100
2331	16.67	0
3111	0	0
3121	0	0
3131	0	0
3211	25	0
3221	0	7.69
3231	0	0
3311	0	0
3321	0	0
3331	83.33	100

The following equations are used in analyzing a three factor classification.

r = replicates

NLA = Number of levels assigned to factor A

NLB = Number of levels assigned to factor B

NLC = Number of levels assigned to factor C

C = Correction term = $G^2 / (NLA \times NLB \times NLC)$

* G = Grand total of all observations

SST = Sum of Squares of the Total = $\sum_i \sum_j \sum_k \sum_l y_{ijkl}^2 - C$

SSR = Sum of Squares of the Replicates = $(1 / (NLA \times NLB \times NLC)) \sum_i R_i^2 - C$

SSA = Sum Squares of Factor A Main Effect = $(1 / (r \times NLB \times NLC)) \sum_j A_j^2 - C$

SSB = Sum Squares of Factor B Main Effect = $(1 / (r \times NLA \times NLC)) \sum_k B_k^2 - C$

SSC = Sum Squares of Factor C Main Effect = $(1 / (r \times NLA \times NLB)) \sum_l C_l^2 - C$

SSAB = Sum of Squares of the AB interaction = $(1 / (r \times NLC)) \sum_j \sum_k T_{jk}^2 - C - SSA - SSB$

SSAC = Sum of Squares of the AC interaction = $(1 / (r \times NLB)) \sum_j \sum_l T_{jl}^2 - C - SSA - SSC$

SSBC = Sum of Squares of the BC interaction = $(1 / (r \times NLA)) \sum_k \sum_l T_{kl}^2 - C - SSB - SSC$

SSABC = Sum of Square of the ABC interaction = $(1 / r) \sum_j \sum_k \sum_l T_{jkl}^2 - C - SSA - SSB - SSC - SSAB - SSAC - SSBC$

SSE = Sum of Square of the Error = $SST - SSR - SSA - SSB - SSC - SSAB - SSAC - SSBC - SSABC$

* Mean Squares (MS) are obtained by dividing the sums of squares by their associated degrees of freedom.

* MSE serves as a denominator of all F ratios.

* $F_{calc} = MS / MSE$

The results of these equations are used to compile an Analysis Of Variance(ANOVA) table which is shown on the following page. The ANOVA table presents the results of the Factorial Experiment.

ANOVA TABLE (COMPUTATION EQUATIONS)

SOURCE OF VARIATION	DEGREES OF FREEDOM	SUM OF SQUARES	MEAN SQUARE	F FACTOR
REPLICATES	NREP-1	SSR	SSR/DOF	MSR/MSE
MAIN EFFECTS FACTOR				
A	NLA-1	SSA	SSA/DOF	MSA/MSE
B	NLB-1	SSB	SSB/DOF	MSB/MSE
C	NLC-1	SSC	SSC/DOF	MSC/MSE
D	NLD-1	SSD	SSD/DOF	MSD/MSE
TWO FACTOR INTERACTION FACTORS				
AB	(NLA-1)(NLB-1)	SSAB	SSAB/DOF	MSAB/MSE
AC	(NLA-1)(NLC-1)	SSAC	SSAC/DOF	MSAC/MSE
AD	(NLA-1)(NLD-1)	SSAD	SSAD/DOF	MSAD/MSE
BC	(NLB-1)(NLC-1)	SSBC	SSBC/DOF	MSBC/MSE
BD	(NLB-1)(NLD-1)	SSBD	SSBD/DOF	MSBD/MSE
CD	(NLC-1)(NLD-1)	SSCD	SSCD/DOF	MSCD/MSE
THREE FACTOR INTERACTION FACTORS				
ABC	(NLA-1)(NLB-1)(NLC-1)	SSABC	SSABC/DOF	MSABC/MSE
ABD	(NLA-1)(NLB-1)(NLD-1)	SSABD	SSABD/DOF	MSABD/MSE
ACD	(NLA-1)(NLC-1)(NLD-1)	SSACD	SSACD/DOF	MSACD/MSE
BCD	(NLB-1)(NLC-1)(NLD-1)	SSBCD	SSBCD/DOF	MSBCD/MSE
FOUR FACTOR INTERACTION FACTORS				
ABCD	(NLA-1)(NLB-1)(NLC-1)(NLD-1)	SSABCD	SSABCD/DOF	MSABCD/MSE
ERROR	(NL1*NL2*NL3*NL4-1)(NREP-1)	SSE	SSE/DOF=MSE	MSE/MSE=1

Following the procedure used in analyzing a three way classification we first compute the correction term.

$$CC = (25 + 100 + 50 + \dots + 100)/(3 \times 3 \times 3 \times 2) = 18,518.52$$

Then the total sum of squares is given by

$$SST = 25^2 + 100^2 + 15.38^2 + \dots + 100^2 - CC = 63,866.62$$

and the treatment and replicate sum of squares are given by

$$SSTR = (125^2 + 15.38^2 + 60^2 + \dots + 183.33^2) / 2 = 51,199.75$$

$$SSR = (500^2 + 499.99^2)/(3 \times 3 \times 3) - CC = .0009$$

Finally by subtraction we obtain

$$SSE = 63,866.62 - 51,199.75 - 0.00094 = 12,666.98$$

Using the formulas for calculating the sum of squares of the three main effects

$$SSA = (200.38^2 + 583.59^2 + 216.02^2)/(3 \times 3 \times 2) - CC = 5225.82$$

$$SSB = (100^2 + 500^2 + 400^2)/(3 \times 3 \times 2) - CC = 4814.81$$

$$SSC = (200^2 + 500^2 + 300^2)/(3 \times 3 \times 2) - CC = 2592.59$$

Using the formulas for calculating the sum of squares of the three interactions

$$SSAB = ((0^2 + 200.38^2 + 0^2 + \dots + 183.33^2)/(3 \times 2)) - CC - SSA - SSB = 5278.56$$

$$SSAC = ((125^2 + 15.38^2 + 60^2 + \dots + 183.33^2)/(3 \times 2)) - CC - SSA - SSC = 21,483.25$$

$$SSBC = ((100^2 + 0^2 + 200^2 + \dots + 200^2)/(3 \times 2)) - CC - SSB - SSC = 4074.07$$

The formula for the three way interaction yields

$$SSABC = ((125^2 + 15.38^2 + 60^2 + \dots + 183.33^2)/2) - CC - SSA - SSB - SSC - SSAB - SSAC - SSBC$$

From the formulas for the calculated F factor we obtain

$$F_R = .0009404/487.2 = 1.903E-06$$

$$F_A = 2613/487.2 = 5.363$$

$$F_B = 2407/487.2 = 4.941$$

$$F_C = 1296/487.2 = 2.661$$

$$F_{AB} = 1320/487.2 = 2.709$$

$$F_{AC} = 5371/487.2 = 11.02$$

$$F_{BC} = 1019/487.2 = 2.091$$

$$F_{ABC} = 966.3/487.2 = 1.983$$

$$F_E = 487.2/487.2 = 1$$

Note that the degrees of freedom for each main effect is one less than the number of levels of the corresponding factor. The degrees of freedom for each interaction is the product of the degrees of freedom for those factors appearing in the interaction.

The following table (ANOVA) shows the complete analysis of variance for this coal and rock cutting experiment.

ANOVA TABLE

SOURCE OF VARIATION	degree's of freedom	SUM OF SQUARES	MEAN SQUARE	F FACTOR
REPLICATES	1	0.0009404	0.0009404	1.903E-06
MAIN EFFECTS				
1	2	5226	2613	5.363
2	2	4815	2407	4.941
3	2	2593	1296	2.661
TWO FACTOR INTERACTION				
1 2	4	5279	1320	2.709
1 3	4	21480	5371	11.02
2 3	4	4074	1019	2.091
THREE FACTOR INTERACTION				
1 2 3	8	7730	966.3	1.983
ERROR	26	12670	487.2	1

From the comparison between the calculated F factor and the required F factor we conclude that

- The difference between levels of analog signal is significant
- The difference between levels of depth-of-cut is significant
- The interaction between the coal/rock hardness ratio is significant

	DFSV/DFMSE	Freq. 5%	Fcalc.
1	1/26	4.24	1.903E-06
2	2/26	3.39	5.363
3	2/26	3.39	4.941
4	2/26	3.39	2.661
5	4/26	2.76	2.709
6	4/26	2.76	11.02
7	4/26	2.76	2.091
8	8/26	2.34	1.983

APPENDIX H

**COMPUTER OUTPUT OF THE PERCENTAGE
OF CUTTING SIGNALS OVERALL**

CID EVALUATION PROGRAM RESULTS

A. EXPERIMENT REPLICATIONS

REPLICATION NUMBER 1

DATA SET 1. 99
DATA SET 2. 18
DATA SET 3. 19
DATA SET 4. 20
DATA SET 5. 21
DATA SET 6. 22
DATA SET 7. 23
DATA SET 8. 24
DATA SET 9. 26

REPLICATION NUMBER 2

DATA SET 1. 4
DATA SET 2. 27
DATA SET 3. 28
DATA SET 4. 29
DATA SET 5. 30
DATA SET 6. 31
DATA SET 7. 32
DATA SET 8. 35
DATA SET 9. 36

REPLICATION NUMBER 3

DATA SET 1. 37
DATA SET 2. 38
DATA SET 3. 39
DATA SET 4. 40
DATA SET 5. 41
DATA SET 6. 42
DATA SET 7. 43
DATA SET 8. 44
DATA SET 9. 45

REPLICATION NUMBER 4

DATA SET 1. 46
DATA SET 2. 47
DATA SET 3. 48
DATA SET 4. 49
DATA SET 5. 50
DATA SET 6. 51
DATA SET 7. 52
DATA SET 8. 53
DATA SET 9. 54

B. EXPERIMENTAL FACTORS AND FACTOR LEVELS

FACTOR NUMBER 1. CID ANALOG SIGNAL CUTTING BAND

LEVEL 1. .000 , 1.00
LEVEL 2. 1.00 , 3.00
LEVEL 3. 3.00 , 5.00
LEVEL 4. 5.00 , 8.00

FACTOR NUMBER 2. DEPTH OF CUT INTO ROCK

LEVEL 1. .000 , .100
LEVEL 2. .100 , 2.00
LEVEL 3. 2.00 , 6.00
LEVEL 4. 6.00 , 60.0

FACTOR NUMBER	3.	CORAL ROCK	THICKNESS	IN FEET
LEVEL 1.	.200	,	.500	
LEVEL 2.	.500	,	.700	
LEVEL 3.	.700	,	.900	
LEVEL 4.	.900	,	1.20	

FACTOR NUMBER	4.	SHEARER	VELOCITY
LEVEL 1.	.000	,	10.0
LEVEL 2.	10.0	,	20.0
LEVEL 3.	20.0	,	33.3
LEVEL 4.	33.3	,	70.0

TABLE C1 C. BASE RESULTS : RUN SELECTION NUMBER. 3

ARRAY INDEX	REP1.	REP2.	REP3.	REP4.
1, 1, 1, 1	.00	.00	.00	.00
1, 1, 1, 2	.00	.00	.00	.00
1, 1, 1, 3	11.49	.00	.00	5.13
1, 1, 1, 4	7.32	.00	.00	3.85
1, 1, 2, 1	.00	.00	.00	.00
1, 1, 2, 2	80.95	80.00	.00	11.76
1, 1, 2, 3	47.93	99.15	.00	5.65
1, 1, 2, 4	17.31	100.00	.00	36.36
1, 1, 3, 1	.00	100.00	.00	.00
1, 1, 3, 2	.00	68.18	99.00	100.00
1, 1, 3, 3	.00	80.00	95.77	92.86
1, 1, 3, 4	.00	82.61	.00	.00
1, 1, 4, 1	100.00	.00	.00	.00
1, 1, 4, 2	.00	.00	.00	.00
1, 1, 4, 3	.00	100.00	.00	.00
1, 1, 4, 4	.00	100.00	.00	.00
1, 2, 1, 1	.00	.00	.00	.00
1, 2, 1, 2	.00	.00	.00	.00
1, 2, 1, 3	.00	.00	.00	11.11
1, 2, 1, 4	.00	.00	.00	.00
1, 2, 2, 1	.00	.00	.00	.00
1, 2, 2, 2	100.00	100.00	.00	.00
1, 2, 2, 3	25.00	.00	.00	.00
1, 2, 2, 4	.00	.00	.00	.00
1, 2, 3, 1	.00	.00	.00	.00
1, 2, 3, 2	.00	87.50	100.00	75.00
1, 2, 3, 3	.00	50.00	75.00	100.00
1, 2, 3, 4	.00	.00	100.00	.00
1, 2, 4, 1	.00	.00	.00	.00
1, 2, 4, 2	.00	.00	.00	.00
1, 2, 4, 3	.00	.00	.00	.00
1, 2, 4, 4	.00	.00	.00	.00
1, 3, 1, 1	.00	.00	.00	.00
1, 3, 1, 2	.00	.00	.00	.00
1, 3, 1, 3	.00	.00	.00	.00
1, 3, 1, 4	.00	.00	.00	.00
1, 3, 2, 1	.00	.00	.00	.00
1, 3, 2, 2	71.43	100.00	.00	.00
1, 3, 2, 3	19.23	75.68	.00	.00
1, 3, 2, 4	22.81	100.00	.00	.00
1, 3, 3, 1	.00	.00	80.00	.00
1, 3, 3, 2	.00	80.00	93.94	100.00
1, 3, 3, 3	.00	89.53	83.22	26.09
1, 3, 3, 4	.00	80.00	75.00	3.09
1, 3, 4, 1	.00	.00	.00	.00
1, 3, 4, 2	.00	33.33	.00	.00
1, 3, 4, 3	.00	.00	.00	.00
1, 3, 4, 4	.00	.00	.00	.00
1, 4, 1, 1	.00	.00	.00	.00
1, 4, 1, 2	.00	.00	.00	50.00
1, 4, 1, 3	.00	.00	.00	14.29
1, 4, 1, 4	.00	.00	.00	.00
1, 4, 2, 1	.00	.00	.00	.00
1, 4, 2, 2	.00	66.67	.00	.00
1, 4, 2, 3	16.13	46.88	.00	.00
1, 4, 2, 4	35.71	53.85	.00	.00
1, 4, 3, 1	.00	20.00	.00	.00
1, 4, 3, 2	.00	22.73	100.00	.00
1, 4, 3, 3	.00	55.45	66.67	.00
1, 4, 3, 4	.00	77.59	50.00	.00

1, 4, 4, 1	.00	.00	.00	.00
1, 4, 4, 2	.00	33.33	.00	.00
1, 4, 4, 3	.00	76.47	.00	.00
1, 4, 4, 4	.00	92.86	.00	.00
2, 1, 1, 1	.00	.00	.00	100.00
2, 1, 1, 2	100.00	.00	.00	93.75
2, 1, 1, 3	88.51	.00	.00	91.03
2, 1, 1, 4	92.68	.00	.00	96.15
2, 1, 2, 1	.00	.00	.00	.00
2, 1, 2, 2	9.52	.00	.00	82.35
2, 1, 2, 3	46.28	.85	.00	85.48
2, 1, 2, 4	51.92	.00	.00	63.64
2, 1, 3, 1	.00	.00	.00	.00
2, 1, 3, 2	.00	.00	1.00	.00
2, 1, 3, 3	100.00	.00	2.82	7.14
2, 1, 3, 4	.00	8.70	100.00	100.00
2, 1, 4, 1	.00	.00	.00	.00
2, 1, 4, 2	.00	100.00	.00	.00
2, 1, 4, 3	.00	.00	.00	.00
2, 1, 4, 4	.00	.00	.00	.00
2, 2, 1, 1	.00	.00	.00	.00
2, 2, 1, 2	.00	.00	.00	50.00
2, 2, 1, 3	.00	.00	.00	38.89
2, 2, 1, 4	.00	.00	.00	.00
2, 2, 2, 1	.00	.00	.00	.00
2, 2, 2, 2	.00	.00	.00	20.00
2, 2, 2, 3	50.00	.00	.00	31.91
2, 2, 2, 4	.00	.00	.00	.00
2, 2, 3, 1	.00	.00	.00	.00
2, 2, 3, 2	.00	12.50	.00	25.00
2, 2, 3, 3	.00	25.00	25.00	.00
2, 2, 3, 4	.00	.00	.00	.00
2, 2, 4, 1	.00	.00	.00	.00
2, 2, 4, 2	.00	.00	.00	.00
2, 2, 4, 3	.00	.00	.00	.00
2, 2, 4, 4	.00	.00	.00	.00
2, 3, 1, 1	.00	.00	.00	100.00
2, 3, 1, 2	.00	.00	.00	.00
2, 3, 1, 3	.00	.00	.00	18.75
2, 3, 1, 4	.00	.00	.00	66.67
2, 3, 2, 1	.00	.00	.00	.00
2, 3, 2, 2	28.57	.00	.00	54.55
2, 3, 2, 3	76.92	24.32	.00	32.43
2, 3, 2, 4	31.58	.00	.00	.00
2, 3, 3, 1	.00	.00	20.00	.00
2, 3, 3, 2	.00	15.00	6.06	.00
2, 3, 3, 3	.00	6.98	14.09	56.52
2, 3, 3, 4	100.00	20.00	12.50	45.45
2, 3, 4, 1	.00	.00	.00	.00
2, 3, 4, 2	.00	66.67	.00	.00
2, 3, 4, 3	.00	100.00	.00	.00
2, 3, 4, 4	.00	.00	.00	.00
2, 4, 1, 1	.00	.00	.00	.00
2, 4, 1, 2	.00	.00	.00	.00
2, 4, 1, 3	100.00	.00	.00	42.86
2, 4, 1, 4	100.00	.00	.00	50.00
2, 4, 2, 1	.00	.00	.00	.00
2, 4, 2, 2	.00	33.33	.00	.00
2, 4, 2, 3	32.26	53.13	.00	100.00
2, 4, 2, 4	16.67	46.15	.00	.00
2, 4, 3, 1	.00	.00	.00	.00
2, 4, 3, 2	.00	10.61	.00	.00
2, 4, 3, 3	.00	11.88	33.33	.00
2, 4, 3, 4	.00	22.41	50.00	.00
2, 4, 4, 1	.00	.00	.00	.00
2, 4, 4, 2	.00	66.67	.00	.00

4,	4,	6	.00	25.00	.00	.00
4,	4,	4	.00	7.14	.00	.00
1,	1,	1	.00	.00	.00	.00
1,	1,	2	.00	.00	.00	6.25
1,	1,	3	.00	.00	.00	3.85
1,	1,	4	.00	.00	.00	.00
1,	2,	1	.00	.00	.00	.00
1,	2,	2	9.52	20.00	.00	5.88
1,	2,	3	5.79	.00	.00	8.87
1,	2,	4	30.77	.00	.00	.00
1,	3,	1	.00	.00	.00	.00
1,	3,	2	.00	31.82	.00	.00
1,	3,	3	.00	20.00	1.41	.00
1,	3,	4	100.00	8.70	.00	.00
1,	4,	1	.00	.00	.00	.00
1,	4,	2	.00	.00	.00	.00
1,	4,	3	.00	.00	.00	.00
1,	4,	4	.00	.00	.00	.00
2,	1,	1	.00	.00	.00	.00
2,	1,	2	.00	.00	.00	50.00
2,	1,	3	.00	.00	.00	50.00
2,	1,	4	.00	.00	.00	100.00
2,	2,	1	.00	.00	.00	.00
2,	2,	2	.00	.00	.00	80.00
2,	2,	3	25.00	.00	.00	68.09
2,	2,	4	.00	.00	.00	100.00
2,	3,	1	.00	.00	.00	.00
2,	3,	2	.00	.00	.00	.00
2,	3,	3	.00	25.00	.00	.00
2,	3,	4	.00	.00	.00	.00
2,	4,	1	.00	.00	.00	.00
2,	4,	2	.00	.00	.00	.00
2,	4,	3	.00	.00	.00	.00
2,	4,	4	.00	.00	.00	.00
3,	1,	1	.00	.00	.00	.00
3,	1,	2	.00	.00	.00	100.00
3,	1,	3	.00	.00	.00	81.25
3,	1,	4	.00	.00	.00	33.33
3,	2,	1	.00	.00	.00	.00
3,	2,	2	.00	.00	.00	45.45
3,	2,	3	3.85	.00	.00	67.57
3,	2,	4	45.61	.00	.00	.00
3,	3,	1	.00	.00	.00	.00
3,	3,	2	.00	5.00	.00	.00
3,	3,	3	.00	3.49	2.68	17.39
3,	3,	4	.00	.00	12.50	45.45
3,	4,	1	.00	.00	.00	.00
3,	4,	2	.00	.00	.00	.00
3,	4,	3	.00	.00	.00	.00
3,	4,	4	.00	.00	.00	.00
4,	1,	1	.00	.00	.00	.00
4,	1,	2	.00	.00	.00	50.00
4,	1,	3	.00	.00	.00	42.86
4,	1,	4	.00	.00	.00	50.00
4,	2,	1	.00	.00	.00	.00
4,	2,	2	.00	.00	.00	.00
4,	2,	3	32.26	.00	.00	.00
4,	2,	4	42.86	.00	.00	.00
4,	3,	1	.00	80.00	.00	.00
4,	3,	2	.00	66.67	.00	.00
4,	3,	3	.00	32.67	.00	100.00
4,	3,	4	.00	.00	.00	100.00
4,	4,	1	.00	.00	.00	.00
4,	4,	2	.00	.00	.00	.00
4,	4,	3	.00	.00	.00	.00
4,	4,	4	.00	.00	.00	.00

4,	1,	1,	1	.00	.00	.00	.00
4,	1,	1,	2	.00	.00	.00	.00
4,	1,	1,	3	.00	.00	.00	.00
4,	1,	1,	4	.00	.00	.00	.00
4,	1,	2,	1	.00	.00	.00	.00
4,	1,	2,	2	.00	.00	.00	.00
4,	1,	2,	3	.00	.00	.00	.00
4,	1,	2,	4	.00	.00	.00	.00
4,	1,	3,	1	.00	.00	.00	.00
4,	1,	3,	2	.00	.00	.00	.00
4,	1,	3,	3	.00	.00	.00	.00
4,	1,	3,	4	.00	.00	.00	.00
4,	1,	4,	1	.00	.00	.00	.00
4,	1,	4,	2	.00	.00	.00	.00
4,	1,	4,	3	.00	.00	.00	.00
4,	1,	4,	4	.00	.00	.00	.00
4,	2,	1,	1	.00	.00	.00	.00
4,	2,	1,	2	.00	.00	.00	.00
4,	2,	1,	3	.00	.00	.00	.00
4,	2,	1,	4	.00	.00	.00	.00
4,	2,	2,	1	.00	.00	.00	.00
4,	2,	2,	2	.00	.00	.00	.00
4,	2,	2,	3	.00	.00	.00	.00
4,	2,	2,	4	.00	.00	.00	.00
4,	2,	3,	1	.00	.00	.00	.00
4,	2,	3,	2	.00	.00	.00	.00
4,	2,	3,	3	.00	.00	.00	.00
4,	2,	3,	4	.00	.00	.00	.00
4,	2,	4,	1	.00	.00	.00	.00
4,	2,	4,	2	.00	.00	.00	.00
4,	2,	4,	3	.00	.00	.00	.00
4,	2,	4,	4	.00	.00	.00	.00
4,	3,	1,	1	.00	.00	.00	.00
4,	3,	1,	2	.00	.00	.00	.00
4,	3,	1,	3	.00	.00	.00	.00
4,	3,	1,	4	.00	.00	.00	.00
4,	3,	2,	1	.00	.00	.00	.00
4,	3,	2,	2	.00	.00	.00	.00
4,	3,	2,	3	.00	.00	.00	.00
4,	3,	2,	4	.00	.00	.00	.00
4,	3,	3,	1	.00	.00	.00	.00
4,	3,	3,	2	.00	.00	.00	.00
4,	3,	3,	3	.00	.00	.00	.00
4,	3,	3,	4	.00	.00	.00	.00
4,	3,	4,	1	.00	.00	.00	.00
4,	3,	4,	2	.00	.00	.00	.00
4,	3,	4,	3	.00	.00	.00	.00
4,	3,	4,	4	.00	.00	.00	.00
4,	4,	1,	1	.00	.00	.00	.00
4,	4,	1,	2	.00	.00	.00	.00
4,	4,	1,	3	.00	.00	.00	.00
4,	4,	1,	4	.00	.00	.00	.00
4,	4,	2,	1	.00	.00	.00	.00
4,	4,	2,	2	.00	.00	.00	.00
4,	4,	2,	3	.00	.00	.00	.00
4,	4,	2,	4	.00	.00	.00	.00
4,	4,	3,	1	.00	.00	.00	.00
4,	4,	3,	2	.00	.00	.00	.00
4,	4,	3,	3	.00	.00	.00	.00
4,	4,	3,	4	.00	.00	.00	.00
4,	4,	4,	1	.00	.00	.00	.00
4,	4,	4,	2	.00	.00	.00	.00
4,	4,	4,	3	.00	.00	.00	.00
4,	4,	4,	4	.00	.00	.00	.00
				19.35	.00	.00	.00
				4.76	.00	.00	.00

TABLE D1 D. TOTAL DATA POINTS : RUN SELECTION NUMBER. 3

ARRAY INDEX	REP1.	REP2.	REP3.	REP4.
1, 1, 1, 1	0	0	0	1
1, 1, 1, 2	36	0	0	16
1, 1, 1, 3	87	0	0	78
1, 1, 1, 4	41	0	0	26
1, 1, 2, 1	0	0	0	0
1, 1, 2, 2	21	5	0	17
1, 1, 2, 3	242	117	0	124
1, 1, 2, 4	52	12	0	11
1, 1, 3, 1	0	2	0	0
1, 1, 3, 2	0	44	100	32
1, 1, 3, 3	1	65	71	56
1, 1, 3, 4	1	23	1	1
1, 1, 4, 1	1	0	0	0
1, 1, 4, 2	0	1	0	0
1, 1, 4, 3	0	2	0	0
1, 1, 4, 4	0	1	0	0
1, 2, 1, 1	0	0	0	0
1, 2, 1, 2	0	0	0	8
1, 2, 1, 3	0	0	0	18
1, 2, 1, 4	0	0	0	1
1, 2, 2, 1	0	0	0	0
1, 2, 2, 2	2	1	0	5
1, 2, 2, 3	8	0	0	47
1, 2, 2, 4	0	0	0	1
1, 2, 3, 1	0	0	0	0
1, 2, 3, 2	0	8	14	4
1, 2, 3, 3	0	4	16	5
1, 2, 3, 4	0	0	1	0
1, 2, 4, 1	0	0	0	0
1, 2, 4, 2	0	0	0	0
1, 2, 4, 3	0	0	0	0
1, 2, 4, 4	0	0	0	0
1, 3, 1, 1	0	0	0	1
1, 3, 1, 2	0	0	0	3
1, 3, 1, 3	0	0	0	16
1, 3, 1, 4	0	0	0	3
1, 3, 2, 1	0	0	0	0
1, 3, 2, 2	7	6	0	11
1, 3, 2, 3	52	37	0	37
1, 3, 2, 4	57	2	0	0
1, 3, 3, 1	0	0	5	0
1, 3, 3, 2	0	20	33	2
1, 3, 3, 3	0	86	149	23
1, 3, 3, 4	1	10	8	11
1, 3, 4, 1	0	0	0	0
1, 3, 4, 2	0	3	0	0
1, 3, 4, 3	0	2	0	0
1, 3, 4, 4	0	0	0	0
1, 4, 1, 1	0	0	0	0
1, 4, 1, 2	0	0	0	2
1, 4, 1, 3	3	0	0	7
1, 4, 1, 4	2	0	0	4
1, 4, 2, 1	0	0	0	0
1, 4, 2, 2	0	3	0	0
1, 4, 2, 3	31	32	0	1
1, 4, 2, 4	42	26	0	0
1, 4, 3, 1	0	5	0	0
1, 4, 3, 2	0	66	5	0
1, 4, 3, 3	0	101	21	1
1, 4, 3, 4	0	58	2	1

1, 4, 4, 1	0	0	0	0
1, 4, 4, 2	0	3	0	0
1, 4, 4, 3	0	17	0	0
1, 4, 4, 4	0	28	0	0
1, 1, 1, 1	0	0	0	1
1, 1, 1, 2	36	0	0	16
1, 1, 1, 3	87	0	0	78
1, 1, 1, 4	41	0	0	26
1, 1, 2, 1	0	0	0	0
1, 1, 2, 2	21	5	0	17
1, 1, 2, 3	242	117	0	124
1, 1, 2, 4	52	12	0	11
1, 1, 3, 1	0	2	0	0
1, 1, 3, 2	0	44	100	32
1, 1, 3, 3	1	65	71	56
1, 1, 3, 4	1	23	1	1
1, 1, 4, 1	1	0	0	0
1, 1, 4, 2	0	1	0	0
1, 1, 4, 3	0	2	0	0
1, 1, 4, 4	0	1	0	0
1, 2, 1, 1	0	0	0	0
1, 2, 1, 2	0	0	0	8
1, 2, 1, 3	0	0	0	18
1, 2, 1, 4	0	0	0	1
1, 2, 2, 1	0	0	0	0
1, 2, 2, 2	2	1	0	5
1, 2, 2, 3	8	0	0	47
1, 2, 2, 4	0	0	0	1
1, 2, 3, 1	0	0	0	0
1, 2, 3, 2	0	8	14	4
1, 2, 3, 3	0	4	16	5
1, 2, 3, 4	0	0	1	0
1, 2, 4, 1	0	0	0	0
1, 2, 4, 2	0	0	0	0
1, 2, 4, 3	0	0	0	0
1, 2, 4, 4	0	0	0	0
1, 3, 1, 1	0	0	0	1
1, 3, 1, 2	0	0	0	3
1, 3, 1, 3	0	0	0	16
1, 3, 1, 4	0	0	0	3
1, 3, 2, 1	0	0	0	0
1, 3, 2, 2	7	6	0	11
1, 3, 2, 3	52	37	0	37
1, 3, 2, 4	57	2	0	0
1, 3, 3, 1	0	0	5	0
1, 3, 3, 2	0	20	33	2
1, 3, 3, 3	0	86	149	23
1, 3, 3, 4	1	10	8	11
1, 3, 4, 1	0	0	0	0
1, 3, 4, 2	0	3	0	0
1, 3, 4, 3	0	2	0	0
1, 3, 4, 4	0	0	0	0
1, 4, 1, 1	0	0	0	0
1, 4, 1, 2	0	0	0	2
1, 4, 1, 3	3	0	0	7
1, 4, 1, 4	2	0	0	4
1, 4, 2, 1	0	0	0	0
1, 4, 2, 2	0	3	0	0
1, 4, 2, 3	31	32	0	1
1, 4, 2, 4	42	26	0	0
1, 4, 3, 1	0	5	0	0
1, 4, 3, 2	0	66	5	0
1, 4, 3, 3	0	101	21	1
1, 4, 3, 4	0	58	2	1
1, 4, 4, 1	0	0	0	0
1, 4, 4, 2	0	3	0	0

4,	1,	1,	1	0	0	0	1
4,	1,	1,	2	26	0	0	16
4,	1,	1,	3	57	0	0	78
4,	1,	1,	4	41	0	0	28
4,	1,	2,	1	0	0	0	0
4,	1,	2,	2	21	5	0	17
4,	1,	2,	3	242	117	0	124
4,	1,	2,	4	52	12	0	11
4,	1,	3,	1	0	2	0	0
4,	1,	3,	2	0	44	100	32
4,	1,	3,	3	1	65	71	56
4,	1,	3,	4	1	23	1	1
4,	1,	4,	1	1	0	0	0
4,	1,	4,	2	0	1	0	0
4,	1,	4,	3	0	2	0	0
4,	1,	4,	4	0	1	0	0
4,	2,	1,	1	0	0	0	0
4,	2,	1,	2	0	0	0	8
4,	2,	1,	3	0	0	0	18
4,	2,	1,	4	0	0	0	1
4,	2,	2,	1	0	0	0	0
4,	2,	2,	2	2	1	0	5
4,	2,	2,	3	8	0	0	47
4,	2,	2,	4	0	0	0	1
4,	2,	3,	1	0	0	0	0
4,	2,	3,	2	0	8	14	4
4,	2,	3,	3	0	4	16	5
4,	2,	3,	4	0	0	1	0
4,	2,	4,	1	0	0	0	0
4,	2,	4,	2	0	0	0	0
4,	2,	4,	3	0	0	0	0
4,	2,	4,	4	0	0	0	0
4,	3,	1,	1	0	0	0	1
4,	3,	1,	2	0	0	0	3
4,	3,	1,	3	0	0	0	16
4,	3,	1,	4	0	0	0	3
4,	3,	2,	1	0	0	0	0
4,	3,	2,	2	7	6	0	11
4,	3,	2,	3	52	37	0	37
4,	3,	2,	4	57	2	0	0
4,	3,	3,	1	0	0	5	0
4,	3,	3,	2	0	20	33	2
4,	3,	3,	3	0	86	143	23
4,	3,	3,	4	1	10	8	11
4,	3,	4,	1	0	0	0	0
4,	3,	4,	2	0	3	0	0
4,	3,	4,	3	0	2	0	0
4,	3,	4,	4	0	0	0	0
4,	4,	1,	1	0	0	0	0
4,	4,	1,	2	0	0	0	2
4,	4,	1,	3	3	0	0	7
4,	4,	1,	4	2	0	0	4
4,	4,	2,	1	0	0	0	0
4,	4,	2,	2	0	3	0	0
4,	4,	2,	3	31	32	0	1
4,	4,	2,	4	42	26	0	0
4,	4,	3,	1	0	5	0	0
4,	4,	3,	2	0	66	5	0
4,	4,	3,	3	0	101	21	1
4,	4,	3,	4	0	58	2	1
4,	4,	4,	1	0	0	0	0
4,	4,	4,	2	0	3	0	0
4,	4,	4,	3	0	17	0	0
4,	4,	4,	4	0	28	0	0

CID EVALUATION PROGRAM RESULTS

A. EXPERIMENT REPLICATIONS

REPLICATION NUMBER 1

DATA SET 1. 99
DATA SET 2. 18
DATA SET 3. 19
DATA SET 4. 20
DATA SET 5. 21
DATA SET 6. 22
DATA SET 7. 23
DATA SET 8. 24
DATA SET 9. 26

REPLICATION NUMBER 2

DATA SET 1. 4
DATA SET 2. 27
DATA SET 3. 28
DATA SET 4. 29
DATA SET 5. 30
DATA SET 6. 31
DATA SET 7. 32
DATA SET 8. 35
DATA SET 9. 36

REPLICATION NUMBER 3

DATA SET 1. 37
DATA SET 2. 38
DATA SET 3. 39
DATA SET 4. 40
DATA SET 5. 41
DATA SET 6. 42
DATA SET 7. 43
DATA SET 8. 44
DATA SET 9. 45

REPLICATION NUMBER 4

DATA SET 1. 46
DATA SET 2. 47
DATA SET 3. 48
DATA SET 4. 49
DATA SET 5. 50
DATA SET 6. 51
DATA SET 7. 52
DATA SET 8. 53
DATA SET 9. 54

B. EXPERIMENTAL FACTORS AND FACTOR LEVELS

FACTOR NUMBER 1. CID ANALOG SIGNAL CUTTING BAND

LEVEL 1. .000 , 1.00
LEVEL 2. 1.00 , 3.00
LEVEL 3. 3.00 , 5.00
LEVEL 4. 5.00 , 8.00

FACTOR NUMBER 2. DEPTH OF CUT INTO ROCK

LEVEL 1. .100 , 2.00
LEVEL 2. 2.00 , 6.00
LEVEL 3. 6.00 , 60.0
LEVEL 4. .000 , .000

FACTOR NUMBER	3.	COAL/ROLA	HARDNESS	RH 10
LEVEL 1.	.200	.	.500	
LEVEL 2.	.500	.	.700	
LEVEL 3.	.700	.	.900	
LEVEL 4.	.900	.	1.20	

FACTOR NUMBER	4.	SHEARER	VELOCITY
LEVEL 1.	.000	,	10.0
LEVEL 2.	10.0	,	20.0
LEVEL 3.	20.0	,	33.3
LEVEL 4.	33.3	,	70.0

TABLE C2

D. BASE RESULTS : RUN SELECTION NUMBER. 4

ARRAY INDEX	REP1.	REP2.	REP3.	REP4.
1, 1, 1, 1	.00	.00	.00	.00
1, 1, 1, 2	.00	.00	.00	.00
1, 1, 1, 3	.00	.00	.00	11.11
1, 1, 1, 4	.00	.00	.00	.00
1, 1, 2, 1	.00	.00	.00	.00
1, 1, 2, 2	100.00	100.00	.00	.00
1, 1, 2, 3	25.00	.00	.00	.00
1, 1, 2, 4	.00	.00	.00	.00
1, 1, 3, 1	.00	.00	.00	.00
1, 1, 3, 2	.00	87.50	100.00	75.00
1, 1, 3, 3	.00	50.00	75.00	100.00
1, 1, 3, 4	.00	.00	100.00	.00
1, 1, 4, 1	.00	.00	.00	.00
1, 1, 4, 2	.00	.00	.00	.00
1, 1, 4, 3	.00	.00	.00	.00
1, 1, 4, 4	.00	.00	.00	.00
1, 2, 1, 1	.00	.00	.00	.00
1, 2, 1, 2	.00	.00	.00	.00
1, 2, 1, 3	.00	.00	.00	.00
1, 2, 1, 4	.00	.00	.00	.00
1, 2, 2, 1	.00	.00	.00	.00
1, 2, 2, 2	71.43	100.00	.00	.00
1, 2, 2, 3	19.23	75.68	.00	.00
1, 2, 2, 4	22.81	100.00	.00	.00
1, 2, 3, 1	.00	.00	80.00	.00
1, 2, 3, 2	.00	80.00	93.94	100.00
1, 2, 3, 3	.00	89.53	83.22	26.09
1, 2, 3, 4	.00	80.00	75.00	9.09
1, 2, 4, 1	.00	.00	.00	.00
1, 2, 4, 2	.00	33.33	.00	.00
1, 2, 4, 3	.00	.00	.00	.00
1, 2, 4, 4	.00	.00	.00	.00
1, 3, 1, 1	.00	.00	.00	.00
1, 3, 1, 2	.00	.00	.00	50.00
1, 3, 1, 3	.00	.00	.00	14.29
1, 3, 1, 4	.00	.00	.00	.00
1, 3, 2, 1	.00	.00	.00	.00
1, 3, 2, 2	.00	66.67	.00	.00
1, 3, 2, 3	16.13	46.88	.00	.00
1, 3, 2, 4	35.71	53.85	.00	.00
1, 3, 3, 1	.00	20.00	.00	.00
1, 3, 3, 2	.00	22.73	100.00	.00
1, 3, 3, 3	.00	55.45	66.67	.00
1, 3, 3, 4	.00	77.59	50.00	.00
1, 3, 4, 1	.00	.00	.00	.00
1, 3, 4, 2	.00	33.33	.00	.00
1, 3, 4, 3	.00	76.47	.00	.00
1, 3, 4, 4	.00	92.86	.00	.00
2, 1, 1, 1	.00	.00	.00	.00
2, 1, 1, 2	.00	.00	.00	50.00
2, 1, 1, 3	.00	.00	.00	38.89
2, 1, 1, 4	.00	.00	.00	.00
2, 1, 2, 1	.00	.00	.00	.00
2, 1, 2, 2	.00	.00	.00	20.00
2, 1, 2, 3	50.00	.00	.00	31.91
2, 1, 2, 4	.00	.00	.00	.00
2, 1, 3, 1	.00	.00	.00	.00
2, 1, 3, 2	.00	12.50	.00	25.00
2, 1, 3, 3	.00	25.00	25.00	.00
2, 1, 3, 4	.00	.00	.00	.00

E, 1, 4, 1	.00	.00	.00	.00
E, 1, 4, 2	.00	.00	.00	.00
E, 1, 4, 3	.00	.00	.00	.00
E, 1, 4, 4	.00	.00	.00	.00
E, 2, 1, 1	.00	.00	.00	100.00
E, 2, 1, 2	.00	.00	.00	.00
E, 2, 1, 3	.00	.00	.00	18.75
E, 2, 1, 4	.00	.00	.00	66.67
E, 2, 2, 1	.00	.00	.00	.00
E, 2, 2, 2	28.57	.00	.00	54.55
E, 2, 2, 3	76.32	24.32	.00	32.43
E, 2, 2, 4	31.58	.00	.00	.00
E, 2, 3, 1	.00	.00	20.00	.00
E, 2, 3, 2	.00	15.00	6.06	.00
E, 2, 3, 3	.00	6.98	14.09	56.52
E, 2, 3, 4	100.00	20.00	12.50	45.45
E, 2, 4, 1	.00	.00	.00	.00
E, 2, 4, 2	.00	66.67	.00	.00
E, 2, 4, 3	.00	100.00	.00	.00
E, 2, 4, 4	.00	.00	.00	.00
E, 3, 1, 1	.00	.00	.00	.00
E, 3, 1, 2	.00	.00	.00	.00
E, 3, 1, 3	100.00	.00	.00	42.86
E, 3, 1, 4	100.00	.00	.00	50.00
E, 3, 2, 1	.00	.00	.00	.00
E, 3, 2, 2	.00	33.33	.00	.00
E, 3, 2, 3	32.26	53.13	.00	100.00
E, 3, 2, 4	16.67	46.15	.00	.00
E, 3, 3, 1	.00	.00	.00	.00
E, 3, 3, 2	.00	10.61	.00	.00
E, 3, 3, 3	.00	11.88	33.33	.00
E, 3, 3, 4	.00	22.41	50.00	.00
E, 3, 4, 1	.00	.00	.00	.00
E, 3, 4, 2	.00	66.67	.00	.00
E, 3, 4, 3	.00	23.53	.00	.00
E, 3, 4, 4	.00	7.14	.00	.00
E, 1, 1, 1	.00	.00	.00	.00
E, 1, 1, 2	.00	.00	.00	50.00
E, 1, 1, 3	.00	.00	.00	50.00
E, 1, 1, 4	.00	.00	.00	100.00
E, 1, 2, 1	.00	.00	.00	.00
E, 1, 2, 2	.00	.00	.00	80.00
E, 1, 2, 3	25.00	.00	.00	68.09
E, 1, 2, 4	.00	.00	.00	100.00
E, 1, 3, 1	.00	.00	.00	.00
E, 1, 3, 2	.00	.00	.00	.00
E, 1, 3, 3	.00	25.00	.00	.00
E, 1, 3, 4	.00	.00	.00	.00
E, 1, 4, 1	.00	.00	.00	.00
E, 1, 4, 2	.00	.00	.00	.00
E, 1, 4, 3	.00	.00	.00	.00
E, 1, 4, 4	.00	.00	.00	.00
E, 2, 1, 1	.00	.00	.00	.00
E, 2, 1, 2	.00	.00	.00	100.00
E, 2, 1, 3	.00	.00	.00	81.25
E, 2, 1, 4	.00	.00	.00	33.33
E, 2, 2, 1	.00	.00	.00	.00
E, 2, 2, 2	.00	.00	.00	45.45
E, 2, 2, 3	3.85	.00	.00	67.57
E, 2, 2, 4	45.61	.00	.00	.00
E, 2, 3, 1	.00	.00	.00	.00
E, 2, 3, 2	.00	5.00	.00	.00
E, 2, 3, 3	.00	3.49	2.68	17.39
E, 2, 3, 4	.00	.00	12.50	45.45
E, 2, 4, 1	.00	.00	.00	.00
E, 2, 4, 2	.00	.00	.00	.00

3, 2, 4, 3	.00	.00	.00	.00
3, 2, 4, 4	.00	.00	.00	.00
3, 3, 1, 1	.00	.00	.00	.00
3, 3, 1, 2	.00	.00	.00	50.00
3, 3, 1, 3	.00	.00	.00	42.86
3, 3, 1, 4	.00	.00	.00	50.00
3, 3, 2, 1	.00	.00	.00	.00
3, 3, 2, 2	.00	.00	.00	.00
3, 3, 2, 3	32.26	.00	.00	.00
3, 3, 2, 4	42.86	.00	.00	.00
3, 3, 3, 1	.00	80.00	.00	.00
3, 3, 3, 2	.00	66.67	.00	.00
3, 3, 3, 3	.00	32.67	.00	100.00
3, 3, 3, 4	.00	.00	.00	100.00
3, 3, 4, 1	.00	.00	.00	.00
3, 3, 4, 2	.00	.00	.00	.00
3, 3, 4, 3	.00	.00	.00	.00
3, 3, 4, 4	.00	.00	.00	.00
4, 1, 1, 1	.00	.00	.00	.00
4, 1, 1, 2	.00	.00	.00	.00
4, 1, 1, 3	.00	.00	.00	.00
4, 1, 1, 4	.00	.00	.00	.00
4, 1, 2, 1	.00	.00	.00	.00
4, 1, 2, 2	.00	.00	.00	.00
4, 1, 2, 3	.00	.00	.00	.00
4, 1, 2, 4	.00	.00	.00	.00
4, 1, 3, 1	.00	.00	.00	.00
4, 1, 3, 2	.00	.00	.00	.00
4, 1, 3, 3	.00	.00	.00	.00
4, 1, 3, 4	.00	.00	.00	.00
4, 1, 4, 1	.00	.00	.00	.00
4, 1, 4, 2	.00	.00	.00	.00
4, 1, 4, 3	.00	.00	.00	.00
4, 1, 4, 4	.00	.00	.00	.00
4, 2, 1, 1	.00	.00	.00	.00
4, 2, 1, 2	.00	.00	.00	.00
4, 2, 1, 3	.00	.00	.00	.00
4, 2, 1, 4	.00	.00	.00	.00
4, 2, 2, 1	.00	.00	.00	.00
4, 2, 2, 2	.00	.00	.00	.00
4, 2, 2, 3	.00	.00	.00	.00
4, 2, 2, 4	.00	.00	.00	.00
4, 2, 3, 1	.00	.00	.00	.00
4, 2, 3, 2	.00	.00	.00	.00
4, 2, 3, 3	.00	.00	.00	.00
4, 2, 3, 4	.00	.00	.00	.00
4, 2, 4, 1	.00	.00	.00	.00
4, 2, 4, 2	.00	.00	.00	.00
4, 2, 4, 3	.00	.00	.00	.00
4, 2, 4, 4	.00	.00	.00	.00
4, 3, 1, 1	.00	.00	.00	.00
4, 3, 1, 2	.00	.00	.00	.00
4, 3, 1, 3	.00	.00	.00	.00
4, 3, 1, 4	.00	.00	.00	.00
4, 3, 2, 1	.00	.00	.00	.00
4, 3, 2, 2	.00	.00	.00	.00
4, 3, 2, 3	19.35	.00	.00	.00
4, 3, 2, 4	4.76	.00	.00	.00
4, 3, 3, 1	.00	.00	.00	.00
4, 3, 3, 2	.00	.00	.00	.00
4, 3, 3, 3	.00	.00	.00	.00
4, 3, 3, 4	.00	.00	.00	.00
4, 3, 4, 1	.00	.00	.00	.00
4, 3, 4, 2	.00	.00	.00	.00
4, 3, 4, 3	.00	.00	.00	.00
4, 3, 4, 4	.00	.00	.00	.00

TABLE D2

D. TOTAL DATA POINTS : RUN SELECTION NUMBER, 4

ARRAY INDEX	REP1.	REP2.	REP3.	REP4.
1, 1, 1, 1	0	0	0	0
1, 1, 1, 2	0	0	0	8
1, 1, 1, 3	0	0	0	18
1, 1, 1, 4	0	0	0	1
1, 1, 2, 1	0	0	0	0
1, 1, 2, 2	2	1	0	5
1, 1, 2, 3	8	0	0	47
1, 1, 2, 4	0	0	0	1
1, 1, 3, 1	0	0	0	0
1, 1, 3, 2	0	8	14	4
1, 1, 3, 3	0	4	16	5
1, 1, 3, 4	0	0	1	0
1, 1, 4, 1	0	0	0	0
1, 1, 4, 2	0	0	0	0
1, 1, 4, 3	0	0	0	0
1, 1, 4, 4	0	0	0	0
1, 2, 1, 1	0	0	0	1
1, 2, 1, 2	0	0	0	3
1, 2, 1, 3	0	0	0	16
1, 2, 1, 4	0	0	0	3
1, 2, 2, 1	0	0	0	0
1, 2, 2, 2	7	6	0	11
1, 2, 2, 3	52	37	0	37
1, 2, 2, 4	57	2	0	0
1, 2, 3, 1	0	0	5	0
1, 2, 3, 2	0	20	33	2
1, 2, 3, 3	0	86	149	23
1, 2, 3, 4	1	10	8	11
1, 2, 4, 1	0	0	0	0
1, 2, 4, 2	0	3	0	0
1, 2, 4, 3	0	2	0	0
1, 2, 4, 4	0	0	0	0
1, 3, 1, 1	0	0	0	0
1, 3, 1, 2	0	0	0	2
1, 3, 1, 3	3	0	0	7
1, 3, 1, 4	2	0	0	4
1, 3, 2, 1	0	0	0	0
1, 3, 2, 2	0	3	0	0
1, 3, 2, 3	31	32	0	1
1, 3, 2, 4	42	26	0	0
1, 3, 3, 1	0	5	0	0
1, 3, 3, 2	0	66	5	0
1, 3, 3, 3	0	101	21	1
1, 3, 3, 4	0	58	2	1
1, 3, 4, 1	0	0	0	0
1, 3, 4, 2	0	3	0	0
1, 3, 4, 3	0	17	0	0
1, 3, 4, 4	0	28	0	0
2, 1, 1, 1	0	0	0	0
2, 1, 1, 2	0	0	0	8
2, 1, 1, 3	0	0	0	18
2, 1, 1, 4	0	0	0	1
2, 1, 2, 1	0	0	0	0
2, 1, 2, 2	2	1	0	5
2, 1, 2, 3	8	0	0	47
2, 1, 2, 4	0	0	0	1
2, 1, 3, 1	0	0	0	0
2, 1, 3, 2	0	8	14	4
2, 1, 3, 3	0	4	16	5
2, 1, 3, 4	0	0	1	0

3, 4, 4	0	0	0
3, 3, 4, 4	0	0	0
3, 3, 1, 1	0	0	0
3, 3, 1, 2	0	0	2
3, 3, 1, 3	3	0	7
3, 3, 1, 4	2	0	4
3, 3, 2, 1	0	0	0
3, 3, 2, 2	0	3	0
3, 3, 2, 3	31	32	1
3, 3, 2, 4	42	26	0
3, 3, 3, 1	0	5	0
3, 3, 3, 2	0	66	5
3, 3, 3, 3	0	101	21
3, 3, 3, 4	0	58	2
3, 3, 4, 1	0	0	0
3, 3, 4, 2	0	3	0
3, 3, 4, 3	0	17	0
3, 3, 4, 4	0	28	0
4, 1, 1, 1	0	0	0
4, 1, 1, 2	0	0	0
4, 1, 1, 3	0	0	18
4, 1, 1, 4	0	0	1
4, 1, 2, 1	0	0	0
4, 1, 2, 2	2	1	5
4, 1, 2, 3	8	0	47
4, 1, 2, 4	0	0	1
4, 1, 3, 1	0	0	0
4, 1, 3, 2	0	8	14
4, 1, 3, 3	0	4	16
4, 1, 3, 4	0	0	1
4, 1, 4, 1	0	0	0
4, 1, 4, 2	0	0	0
4, 1, 4, 3	0	0	0
4, 1, 4, 4	0	0	0
4, 2, 1, 1	0	0	1
4, 2, 1, 2	0	0	3
4, 2, 1, 3	0	0	16
4, 2, 1, 4	0	0	3
4, 2, 2, 1	0	0	0
4, 2, 2, 2	7	6	11
4, 2, 2, 3	52	37	37
4, 2, 2, 4	57	2	0
4, 2, 3, 1	0	0	0
4, 2, 3, 2	0	20	5
4, 2, 3, 3	0	86	149
4, 2, 3, 4	1	10	8
4, 2, 4, 1	0	0	0
4, 2, 4, 2	0	3	0
4, 2, 4, 3	0	2	0
4, 2, 4, 4	0	0	0
4, 3, 1, 1	0	0	0
4, 3, 1, 2	0	0	2
4, 3, 1, 3	3	0	7
4, 3, 1, 4	2	0	4
4, 3, 2, 1	0	0	0
4, 3, 2, 2	0	3	0
4, 3, 2, 3	31	32	1
4, 3, 2, 4	42	26	0
4, 3, 3, 1	0	5	0
4, 3, 3, 2	0	66	5
4, 3, 3, 3	0	101	21
4, 3, 3, 4	0	58	2
4, 3, 4, 1	0	0	0
4, 3, 4, 2	0	3	0
4, 3, 4, 3	0	17	0
4, 3, 4, 4	0	28	0

APPENDIX J

**COMPUTER OUTPUT OF THE PERCENTAGE
OF COAL CUTTING SIGNALS**

CID EVALUATION PROGRAM RESULTS

A. EXPERIMENT REPLICATIONS

REPLICATION NUMBER 1

DATA SET	1.	99
DATA SET	2.	18
DATA SET	3.	19
DATA SET	4.	20
DATA SET	5.	21
DATA SET	6.	22
DATA SET	7.	23
DATA SET	8.	24
DATA SET	9.	26

REPLICATION NUMBER 2

DATA SET	1.	4
DATA SET	2.	27
DATA SET	3.	28
DATA SET	4.	29
DATA SET	5.	30
DATA SET	6.	31
DATA SET	7.	32
DATA SET	8.	35
DATA SET	9.	36

REPLICATION NUMBER 3

DATA SET	1.	37
DATA SET	2.	38
DATA SET	3.	39
DATA SET	4.	40
DATA SET	5.	41
DATA SET	6.	42
DATA SET	7.	43
DATA SET	8.	44
DATA SET	9.	45

REPLICATION NUMBER 4

DATA SET	1.	46
DATA SET	2.	47
DATA SET	3.	48
DATA SET	4.	49
DATA SET	5.	50
DATA SET	6.	51
DATA SET	7.	52
DATA SET	8.	53
DATA SET	9.	54

B. EXPERIMENTAL FACTORS AND FACTOR LEVELS

FACTOR NUMBER 1. CID ANALOG SIGNAL CUTTING BAND

LEVEL	1.	.000	,	1.00
LEVEL	2.	1.00	,	3.00
LEVEL	3.	3.00	,	5.00
LEVEL	4.	5.00	,	8.00

FACTOR NUMBER 2. DEPTH OF CUT INTO ROCK

LEVEL	1.	.000	,	.100
LEVEL	2.	.000	,	.000
LEVEL	3.	.000	,	.000
LEVEL	4.	.000	,	.000

FACTOR NUMBER	3.	CURL/ROCK HARDNESS RATIO
LEVEL 1.	.200	, .500
LEVEL 2.	.500	, .700
LEVEL 3.	.700	, .900
LEVEL 4.	.900	, 1.20

FACTOR NUMBER	4.	SHEARER VELOCITY
LEVEL 1.	.000	, 10.0
LEVEL 2.	10.0	, 20.0
LEVEL 3.	20.0	, 33.3
LEVEL 4.	33.3	, 70.0

TABLE C3 C. BASE RESULTS : RUN SELECTION NUMBER. 5

ARRAY INDEX	REP1.	REP2.	REP3.	REP4.
1, 1, 1, 1	.00	.00	.00	.00
1, 1, 1, 2	.00	.00	.00	.00
1, 1, 1, 3	11.49	.00	.00	5.13
1, 1, 1, 4	7.32	.00	.00	3.85
1, 1, 2, 1	.00	.00	.00	.00
1, 1, 2, 2	80.95	80.00	.00	11.76
1, 1, 2, 3	47.93	99.15	.00	5.65
1, 1, 2, 4	17.31	100.00	.00	36.36
1, 1, 3, 1	.00	100.00	.00	.00
1, 1, 3, 2	.00	68.18	99.00	100.00
1, 1, 3, 3	.00	80.00	95.77	92.86
1, 1, 3, 4	.00	82.61	.00	.00
1, 1, 4, 1	100.00	.00	.00	.00
1, 1, 4, 2	.00	.00	.00	.00
1, 1, 4, 3	.00	100.00	.00	.00
1, 1, 4, 4	.00	100.00	.00	.00
2, 1, 1, 1	.00	.00	.00	100.00
2, 1, 1, 2	100.00	.00	.00	93.75
2, 1, 1, 3	88.51	.00	.00	91.03
2, 1, 1, 4	92.68	.00	.00	96.15
2, 1, 2, 1	.00	.00	.00	.00
2, 1, 2, 2	9.52	.00	.00	82.35
2, 1, 2, 3	46.28	.85	.00	85.48
2, 1, 2, 4	51.92	.00	.00	63.64
2, 1, 3, 1	.00	.00	.00	.00
2, 1, 3, 2	.00	.00	1.00	.00
2, 1, 3, 3	100.00	.00	2.82	7.14
2, 1, 3, 4	.00	8.70	100.00	100.00
2, 1, 4, 1	.00	.00	.00	.00
2, 1, 4, 2	.00	100.00	.00	.00
2, 1, 4, 3	.00	.00	.00	.00
2, 1, 4, 4	.00	.00	.00	.00
3, 1, 1, 1	.00	.00	.00	.00
3, 1, 1, 2	.00	.00	.00	6.25
3, 1, 1, 3	.00	.00	.00	3.85
3, 1, 1, 4	.00	.00	.00	.00
3, 1, 2, 1	.00	.00	.00	.00
3, 1, 2, 2	9.52	20.00	.00	5.88
3, 1, 2, 3	5.79	.00	.00	8.87
3, 1, 2, 4	30.77	.00	.00	.00
3, 1, 3, 1	.00	.00	.00	.00
3, 1, 3, 2	.00	31.82	.00	.00
3, 1, 3, 3	.00	20.00	1.41	.00
3, 1, 3, 4	100.00	8.70	.00	.00
3, 1, 4, 1	.00	.00	.00	.00
3, 1, 4, 2	.00	.00	.00	.00
3, 1, 4, 3	.00	.00	.00	.00
3, 1, 4, 4	.00	.00	.00	.00
4, 1, 1, 1	.00	.00	.00	.00
4, 1, 1, 2	.00	.00	.00	.00
4, 1, 1, 3	.00	.00	.00	.00
4, 1, 1, 4	.00	.00	.00	.00
4, 1, 2, 1	.00	.00	.00	.00
4, 1, 2, 2	.00	.00	.00	.00
4, 1, 2, 3	.00	.00	.00	.00
4, 1, 2, 4	.00	.00	.00	.00
4, 1, 3, 1	.00	.00	.00	.00
4, 1, 3, 2	.00	.00	.00	.00
4, 1, 3, 3	.00	.00	.00	.00
4, 1, 3, 4	.00	.00	.00	.00

4.	1.	4.	1	.00	.00	.00	.00
4.	1.	4.	2	.00	.00	.00	.00
4.	1.	4.	3	.00	.00	.00	.00
4.	1.	4.	4	.00	.00	.00	.00

TABLE D3 D. TOTAL DATA POINTS : RUN SELECTION NUMBER, 5

ARRAY INDEX	REP1.	REP2.	REP3.	REP4.
1, 1, 1, 1	0	0	0	1
1, 1, 1, 2	36	0	0	16
1, 1, 1, 3	87	0	0	78
1, 1, 1, 4	41	0	0	26
1, 1, 2, 1	0	0	0	0
1, 1, 2, 2	21	5	0	17
1, 1, 2, 3	242	117	0	124
1, 1, 2, 4	52	12	0	11
1, 1, 3, 1	0	2	0	0
1, 1, 3, 2	0	44	100	32
1, 1, 3, 3	1	65	71	56
1, 1, 3, 4	1	23	1	1
1, 1, 4, 1	1	0	0	0
1, 1, 4, 2	0	1	0	0
1, 1, 4, 3	0	2	0	0
1, 1, 4, 4	0	1	0	0
2, 1, 1, 1	0	0	0	1
2, 1, 1, 2	36	0	0	16
2, 1, 1, 3	87	0	0	78
2, 1, 1, 4	41	0	0	26
2, 1, 2, 1	0	0	0	0
2, 1, 2, 2	21	5	0	17
2, 1, 2, 3	242	117	0	124
2, 1, 2, 4	52	12	0	11
2, 1, 3, 1	0	2	0	0
2, 1, 3, 2	0	44	100	32
2, 1, 3, 3	1	65	71	56
2, 1, 3, 4	1	23	1	1
2, 1, 4, 1	1	0	0	0
2, 1, 4, 2	0	1	0	0
2, 1, 4, 3	0	2	0	0
2, 1, 4, 4	0	1	0	0
3, 1, 1, 1	0	0	0	1
3, 1, 1, 2	36	0	0	16
3, 1, 1, 3	87	0	0	78
3, 1, 1, 4	41	0	0	26
3, 1, 2, 1	0	0	0	0
3, 1, 2, 2	21	5	0	17
3, 1, 2, 3	242	117	0	124
3, 1, 2, 4	52	12	0	11
3, 1, 3, 1	0	2	0	0
3, 1, 3, 2	0	44	100	32
3, 1, 3, 3	1	65	71	56
3, 1, 3, 4	1	23	1	1
3, 1, 4, 1	1	0	0	0
3, 1, 4, 2	0	1	0	0
3, 1, 4, 3	0	2	0	0
3, 1, 4, 4	0	1	0	0
4, 1, 1, 1	0	0	0	1
4, 1, 1, 2	36	0	0	16
4, 1, 1, 3	87	0	0	78
4, 1, 1, 4	41	0	0	26
4, 1, 2, 1	0	0	0	0
4, 1, 2, 2	21	5	0	17
4, 1, 2, 3	242	117	0	124
4, 1, 2, 4	52	12	0	11
4, 1, 3, 1	0	2	0	0
4, 1, 3, 2	0	44	100	32
4, 1, 3, 3	1	65	71	56
4, 1, 3, 4	1	23	1	1

4,	1,	4,	1	1	0	0	0
4,	1,	4,	2	0	1	0	0
4,	1,	4,	3	0	2	0	0
4,	1,	4,	4	0	1	0	0