

A mining research contract report  
FEBRUARY 1985

U.S. DEPARTMENT OF LABOR MSHA



00031754

# AN ALTERNATE METHOD TO EVALUATE MINE GROUND SYSTEM SAFETY

OFR 1985-117

Contract H0338023

West Virginia University

BUREAU OF MINES

UNITED STATES DEPARTMENT OF THE INTERIOR

OFR  
85-117



*The views and conclusions contained in this document are those of the authors and should not be interpreted as necessarily representing the official policies or recommendations of the Interior Department's Bureau of Mines or of the U.S. Government.*

50772-101

<b>REPORT DOCUMENTATION PAGE</b>	<b>1. REPORT NO.</b>	<b>2.</b>	<b>3. Recipient's Accession No.</b>
<b>4. Title and Subtitle</b> An Alternate Method to Evaluate Mine Ground System Safety		<b>5. Report Date</b> February 1985	
<b>7. Author(s)</b> W.L. Cooley, H.W. Hill, and M.L. Maberry		<b>6.</b>	
<b>9. Performing Organization Name and Address</b> Dept. of Electrical Engineering College of Engineering West Virginia University Morgantown, WV 26506-6101		<b>8. Performing Organization Rept. No.</b>	
<b>12. Sponsoring Organization Name and Address</b> Department of the Interior Bureau of Mines 2401 E. Street, NW Washington, DC 20241		<b>10. Project/Task/Work Unit No.</b>	
		<b>11. Contract(C) or Grant(G) No.</b> (C) H0338023 (G)	
		<b>13. Type of Report &amp; Period Covered</b> Final Report	
<b>15. Supplementary Notes</b>		<b>14.</b> 9/26/83-2/25/85	
<b>16. Abstract (Limit 200 words)</b> A significantly different method of evaluating mine ground system safety is investigated. The method measures touch and step potentials around ground beds and grounded equipment resulting from a series of extremely small simulated faults. The values are then scaled for a full-scale fault. The method should be particularly useful for large ground beds and under conditions where the ground bed cannot be isolated from the rest of the ground system in order to make traditional ground bed resistance measurements.  Instrumentation for making the alternative measurements is evaluated under rigorous field conditions. A step-by-step procedure is proposed for evaluating a surface mine ground system. This procedure was subject to several field tests at eastern metal/non-metal mines. The final evaluation procedure is written as a stand-alone document for use by MSHA inspectors and mine operating personnel, and is included as an appendix to the report. The authors conclude that the procedure is effective in evaluating ground system safety and recommend that it be further evaluated in the field.			
<b>17. Document Analysis a. Descriptors</b> Mine Safety Accident Prevention Electric Shock Grounding <b>b. Identifiers/Open-Ended Terms</b> Electrical Hazards, Touch Potentials, Step Potentials, Earth Grounding, Electrical Safety  <b>c. COSATI Field/Group</b> Field 9, Group C, Electronic and Electrical Engineering			
<b>18. Availability Statement</b> Release Unlimited		<b>19. Security Class (This Report)</b> unclassified	<b>21. No. of Pages</b> 138
		<b>20. Security Class (This Page)</b> unclassified	<b>22. Price</b>

## FOREWORD

This report was prepared by the Electrical Engineering Department, College of Engineering, West Virginia University, under Bureau of Mines Contract No. H0338023. The contract was initiated under the Health and Safety Technology Program. It was administered under the technical direction of the Pittsburgh Research Center with Mr. Michael R. Yenchek acting as Technical Project Officer. Mr. Joseph A. Gilchrist was the contracting administrator for the Bureau of Mines. This report is a summary of the work recently completed as a part of this contract during the period from September 26, 1983 to February 25, 1985. This report was submitted by the authors in February 1985.

This report contains no patentable or copyrighted material and has been reviewed and approved.

## EXECUTIVE SUMMARY

The functions of the mine ground system are to reduce the shock hazard to persons working with electrically powered equipment, to limit voltage transients on electrical equipment, and to provide a means of detecting that a fault has occurred on the mine electrical system. There are several approaches to power system grounding, but the Code of Federal Regulations requires an isolated resistance-grounded mine power system for coal mines, and will soon require a similar arrangement for metal/non-metal mines. Although the most important function of the mine ground system is to enhance safety for operating personnel, the degree of safety cannot be assessed for mines with large, interconnected ground systems using present measurement techniques.

Present measurement techniques are based on a concept that personnel safety is directly related to the resistance of the mine ground-bed connection to earth, and on no other parameter. This simple relationship is valid for mines with small ground fields and few ground connections, but it is invalid for mines with large ground fields for two main reasons. First, shock hazard can be shown to be unrelated to ground bed resistance when the ground field is large and interconnected with many grounded structures on the mine property, so that the measurement of ground-bed resistance does not provide a meaningful measure of safety. Second, the resistance of large interconnected systems cannot be measured accurately by any known practical technique. Furthermore, the present technique requires that mine operation be suspended during the ground-bed resistance measurements, a practice which is very expensive for large operations. Chapter 2 of this report reviews the traditional fall-of-potential approach to ground bed resistance measurement in some detail, and concludes that it interrupts production, subjects measurement personnel to shock hazards, is impossible to perform on large systems, and often does not provide a good measure of the safety of a ground system. It concludes that a new approach is needed to evaluate ground system safety, one that does not interrupt production, can be used on large or interconnected systems, reduces the shock hazard to measurement personnel, and provides a direct measure of the safety of a ground system. The chapter ends with a study of electrical system diagrams of typical mining operations, which are used to provide a basis for the development of the new in-mine measurement procedure.

Chapter 3 provides a theoretical analysis of touch potentials as functions of ground fault location and magnitude. It contains a brief review of the concepts of earth resistance and mutual resistance, and develops equations for potentials which arise when ground currents flow through these resistances. Models of gradually increasing complexity are derived throughout the chapter. An analysis within the chapter shows that the single line-to-ground fault produces the most hazardous touch potentials to personnel.

Chapter 4 reports on the computer modelling of the equations developed in Chapter 3. Major use of the computer is made to complete a sensitivity analysis of the touch potentials to a variety of parameters: earth resistivity, equipment size, ground bed size, and relative locations of the fault, ground bed, and grounded equipment. The purpose of these studies is to

provide guidelines as to the fault locations and conditions that will produce the most hazardous step and touch potentials. As expected, the most hazardous fault locations tend to be near grounded equipment. However, one unexpected result was that the side of a ground bed opposite a nearby fault is more likely to support hazardous touch potentials than is the area between the ground bed and the fault. To better understand the spatial variation of touch potentials around grounded equipment, computer-generated equipotential maps were drawn and included in the chapter. This helped in identifying the areas of the highest touch potential. Sharp corners and long extensions of grounded equipment were found to be especially dangerous.

Chapter 5 contains a description of the main task in the contracted work, which was the development of a new test procedure (found to be necessary in the first two chapters). The procedure itself is explained in Appendix B. The text here provides some annotations to that procedure, and details the limitations and features in more detail than is provided in the appendix, along with a description of the procedure's development. Safety was seen as the central issue in the development.

Choice of the test instrument is of great importance, and the qualification of one particular commercial instrument (the James G. Biddle Company Model DET-2 Digital Earth Tester\*) takes up much of the chapter. An extensive series of stray-current tests were executed at the West Virginia University ground bed and described in this chapter. The field tests also provided verification of the computer models of Chapter 4 and the analysis contained in Chapter 3. Most important, however, were the staged-fault tests done to compare the instrument readings to the actual touch potentials produced by earth faults. Excellent agreement was obtained between the staged-fault tests and the instrument readings, thus confirming that the new procedure is valid in assessing potentials around energized ground systems.

Once the instrument and test procedure had been checked out, the next task was to evaluate their performance in an actual mining environment. Chapter 6 describes this phase of the work. Mining operations were sought which would provide a challenging test for procedure and instrument. Two different cooperative quarries were visited which appeared to meet this criteria. The instrument proved to be adequate for measuring step and touch potentials in every case where hazards existed. The procedure worked very well and even identified potentially hazardous situations which presently-used techniques were not able to identify, thus confirming the need for better ground-safety evaluation procedures than presently exist.

Chapter 7 contains the conclusions of the project and the recommendations for future work. The instrument chosen, while not inexpensive, appears to be the best choice for applying the measurement procedure in any environment where stray current is expected to be a problem. The procedure worked very well during the testing period, and should be evaluated further by unbiased groups under a variety of field conditions.

---

\*Reference to specific brands, equipment, or trade names in this report is made to facilitate understanding and does not imply endorsement by the Bureau of Mines.

Appendix A is a listing of some metal/non-metal electrical accidents related to, or possibly related to, inadequate mine ground systems. As explained in Chapter 2, the available descriptions contained in the official reports often contain less information than would be required to make a clear decision as to an accident's root cause.

Appendix B contains a complete, stand-alone version of the proposed procedure. This appendix can be copied from the report to serve as a document to be further evaluated for possible industry adoption.

## CONTENTS

	Page
LIST OF TABLES.....	11
LIST OF FIGURES .....	12
 CHAPTER 1 - INTRODUCTION	
1.1 Function of a Ground System .....	15
1.2 Touch and Step Potentials .....	16
1.2.1 Potentials on Localized Ground Systems .....	17
1.2.2 Potentials on Large Interconnected Ground Systems..	18
 CHAPTER 2 - ASSESSMENT OF GROUND SYSTEM SAFETY	
2.1 Review of Electrical Accidents .....	20
2.2 No Direct Measurement Procedure .....	20
2.3 Fall-of-Potential Resistance Measurement .....	21
2.4 Proposed New Method .....	24
2.5 Study of Electrical System Diagrams .....	25
 CHAPTER 3 - DEVELOPMENT OF TOUCH POTENTIAL EQUATIONS	
3.1 Resistance of Hemispherical Electrodes .....	32
3.2 Mutual Resistance of Hemispherical Electrodes .....	33
3.3 Potentials Appearing on Electrodes During Faults .....	33
3.4 Touch Potentials Between Man and Machine .....	36
3.4.1 Single-Phase Fault.....	40
3.4.2 Double-Phase Fault.....	42
3.4.3 Triple-Phase Fault.....	44
3.4.4 Worst-Case Phase-to-Earth Fault.....	44
3.5 Touch Potentials Between Man and Machine.....	46
3.5.1 No Ground Bed, Single-Hemisphere Machine.....	46

## CONTENTS (continued)

3.5.2 With Ground Bed, Single-Hemisphere Machine.....	49
3.5.3 Double-Hemisphere Machine.....	52
3.5.4 Dual Current Sources, Single-Hemisphere Machine.....	55
 CHAPTER 4 - COMPUTER ANALYSIS OF TOUCH POTENTIALS	
4.1 Sensitivity Analysis of Each Parameter.....	61
4.2 Touch Potentials .....	66
4.2.1 Distant Faults .....	66
4.2.2 Nearby Faults .....	71
4.3 Equipotential Maps .....	78
4.4 Identification of Areas with Highest Touch Potential .....	84
4.4.1 Nearby Faults .....	84
4.4.2 Ground Bed Opposite Fault .....	84
4.4.3 Sharp Corners and Extensions of Machines .....	84
 CHAPTER 5 - DEVELOPMENT OF TEST PROCEDURE	
5.1 Safety as the Central Issue .....	86
5.2 Choice of Instrument .....	86
5.2.1 Accuracy .....	86
5.2.2 Effects of Stray Current .....	88
5.3 Construction of Interconnected Ground System at WVU .....	88
5.3.1 Confirmation of Computer Analysis of Equations .....	91
5.3.2 Estimation of Fault Current .....	91
5.4 Comparison of Procedure with Staged-Fault Tests .....	96

## CONTENTS (continued)

## CHAPTER 6 - EVALUATION OF TEST PROCEDURE

6.1 Description of Mines Visited .....	97
6.2 Field Data Taken .....	97
6.2.1 Granite Quarry .....	97
6.2.2 Traprock Quarry .....	102
6.2.3 Difficulty Obtaining Data .....	110
6.3 Effectiveness of Procedure .....	110

## CHAPTER 7 - CONCLUSIONS AND RECOMMENDATIONS

7.1 Performance of the DET-2*.....	111
7.2 Reliability of Procedure in Assessing Safety .....	111
7.3 Overall Difficulty in Making Measurements .....	112
7.4 Recommendations for Additional Tests of the Procedure .....	112
7.5 Recommendations for Possible Revisions of Procedure .....	113

LIST OF REFERENCES.....	114
-------------------------	-----

APPENDIX A -ELECTRICAL ACCIDENTS RELATED TO GROUNDING SYSTEMS IN METAL/NON-METAL MINES .....	115
---	-----

APPENDIX B - PROCEDURE FOR THE DIRECT MEASUREMENT OF TOUCH POTENTIALS .....	117
--	-----

-----  
\*Reference to specific brands, equipment, or trade names in this report is made to facilitate understanding and does not imply endorsement by the Bureau of Mines.

## LIST OF TABLES

Table		Page
5.1	Instruments Considered for Use with Ground System Evaluation Procedure.....	87
5.2	Meter Stray-Current Test.....	89
5.3	Stray Current Test of Four Resistance Meters.....	90

## LIST OF FIGURES

Figure	Page
2.1 Fall-of-Potential Method.....	22
2.2 Fall-of-Potential Characteristic Resistance Curve.....	23
2.3 Open Pit Mine Electrical System.....	26
2.4 Uranium Mine Surface Facility.....	28
2.5 Gypsum Mine Conveyor System.....	29
2.6 Underground Mine Electrical System Surface Electrical Systems for Underground Salt Mine.....	30
3.1 Ground Fault Near Two Hemispherical Electrodes.....	34
3.2 Ground Fault Near Two Hemispherical Electrodes with One Electrode Carrying the Fault Current.....	35
3.3 Symmetrical Components of an Unbalanced Three-Phase System..	37
3.4 Sequence Networks for Three-Phase System.....	39
3.5 Single-Phase Ground Fault.....	41
3.6 Double-Phase Ground Fault.....	43
3.7 Triple-Phase Ground Fault.....	45
3.8 Touch Potential, Ground Fault Near Single-Hemisphere Machine	47
3.9 Ground FAULT Showing Phase Voltage and Grounding Resistor...	48
3.10 Ground Fault Near a Machine Connected to a Ground Bed.....	50
3.11 Machine Modeled with Two Hemispheres.....	53
3.12 Dual Current Sources in the Machine Electrode.....	57
3.13 Location of Secondary Current Sources in the Machine Electrode.....	58
4.1 Touch Potential vs. Radius of Ground Fault.....	62
4.2 Touch Potential vs. Distance between Machine to Ground Bed..	63
4.3 Touch Potential vs. Source Impedance.....	64
4.4 Touch Potential vs. Earth Resistivity.....	65

## LIST OF FIGURES (continued)

Figure	Page
4.5 Touch Potential vs. Radius of Machine.....	67
4.6 Touch Potential vs. Radius of Ground Bed.....	68
4.7 Touch Potentials Around a Single-Hemisphere Machine (Single Current Source), Ground Bed Closer to Machine than Fault....	69
4.8 Touch Potentials Around a Single-Hemisphere Machine (Single Current Source), Fault Closer to Machine than Ground Bed....	70
4.9 Touch Potentials Around a Single-Hemisphere Machine (Dual Current Sources), Ground Bed Closer to Machine than Fault...	72
4.10 Touch Potentials Around a Single-Hemisphere Machine (Dual Current Sources), Fault Closer to Machine than Ground Bed...	73
4.11 Touch Potentials Around a Double-Hemisphere Machine, Fault Near Narrow End.....	74
4.12 Touch Potentials Around a Double-Hemisphere Machine, Fault Near Long Side.....	75
4.13 Touch Potentials Around a Single-Hemisphere Machine (Single Current Source), for a Nearby Fault.....	76
4.14 Touch Potentials Around a Single-Hemisphere Machine (Dual Current Source), for a Nearby Fault.....	77
4.15 Touch Potentials Around a Double-Hemisphere Machine for a Nearby Fault, Fault Off of Narrow End.....	79
4.16 Touch Potentials Around a Double-Hemisphere Machine for a Nearby Fault, Fault Off of Long Side.....	80
4.17 Potential Map, Single-Hemisphere Machine.....	81
4.18 Potential Map, Double-Hemisphere Machine, Fault Near Narrow End.....	82
4.19 Potential Map, Double-Hemisphere Machine, Fault Near Long Side.....	83
5.1 Resistance of WVU Ground Bed, Fall-of-Potential Method.....	92
5.2 Touch Potentials on WVU Ground Bed, Distant Fault.....	93
5.3 Maximum Touch Potentials for Faults Near the WVU Ground Bed.	94

## LIST OF FIGURES (continued)

Figure		Page
5.4	Touch Potentials with New Ground Bed as Return Current Electrode.....	95
6.1	Granite Quarry.....	98
6.2	Traprock Quarry.....	99
6.3	Touch Potential Measurements at Granite Quarry Substation...	101
6.4	Touch Potential Measurements at Crane Guy Wire, Granite Quarry.....	103
6.5	Touch Potential Measurements at Rail-Road Track, Granite Quarry.....	104
6.6	Touch Potential Measurements at Traprock Quarry Main Substation; Fault to Ground.....	106
6.7	Touch Potential Measurements at Traprock Quarry Main Substation; Fault to Metal Drain Pipe.....	108
6.8	Touch Potential Measurements at the Crushing Plant, Traprock Quarry.....	109
B.1	Measuring Touch Potential at a Machine with a Circular Footprint.....	120
B.2	Measuring Touch Potential at a Machine with a Square Footprint, Fault Nearest One Side.....	124
B.3	Measuring Touch Potential at a Machine with a Square Footprint, Fault Nearest one Corner.....	126
B.4	Measuring Touch Potential at a Machine with a Rectangular Footprint, Fault Nearest a Long Side.....	128
B.5	Measuring Touch Potential at a Machine with a Rectangular Footprint, Fault Nearest a Short Side.....	130
B.6	Measuring Touch Potential at a Machine with a Rectangular Footprint, Fault Nearest One Corner.....	132
B.7	Determination of Expected Fault Current.....	137

## CHAPTER 1 - INTRODUCTION

### 1.1 FUNCTION OF A GROUND SYSTEM

Ever since an early controversy between Thomas Edison and Westinghouse Electric Company about the safety of ac versus dc power, there has been considerable concern about the shock hazard associated with the use of electrically-powered equipment. The main function of a ground system is to ensure the safety of personnel in the vicinity of electrical equipment. Secondary functions include the protection of equipment from damaging transients and the establishment of a reliable means of detecting and locating ground faults within a power system.

Sixty-Hertz electrical current flow as small as 100 milliamperes RMS hand-to-hand or hand-to-foot is sufficient to cause death by heart fibrillation.[1] Depending on how well a potential victim is insulated at his contact points (bare hands and feet versus gloves and rubber boots), severe shock may occur with as little as 50 volts RMS potential difference. Since the transmission, distribution, and utilization voltages present at a typical mine range from 480 to 138,000 volts RMS, any leakage of current from the associated electrical equipment can present a significant shock hazard. A properly designed ground system can limit to a safe level the voltages which appear in the earth and on equipment frames under most conditions of faulted conductors, lightning strike, and faulty equipment.

Most residential, commercial, and industrial electrical installations utilize a ground system in which all conducting objects within the work space are interconnected and connected to earth at the power service entrance. This approach causes all water-piping, gas lines, metal-enclosed equipment, reinforced concrete, and building steel to be at roughly the same potential under most conditions of lightning strike or power system fault. Since all conducting floors, walls, and equipment enclosures are held to approximately the same potential under all conditions, no local potential difference can develop which would cause shock current to flow through the body of a person in simultaneous contact with several of these items.

Hospitals and mines often use a different approach to grounding. In both cases, separated isolated ground systems are derived to avoid a shock hazard that develops because of special environmental conditions. In hospitals, the isolated ground is necessitated in critical care areas because the more traditional grounding approach does allow small voltage differences to appear within the ground system due to resistive voltage-drop under high current fault conditions. These small differences can be lethal for patients having catheters, monitoring electrodes, and other devices in good electrical contact with the body. In mines, the problem is that the "floor and walls" are usually not part of the ground system. Since they are not part of the ground system, voltage differences between the floor or walls (for an underground mine) and the frames of grounded equipment cannot be controlled easily. Under these conditions, safety is assured principally by limiting the absolute voltages to safe levels. Certainly if the absolute voltage of grounded machine frames and the absolute voltage of local earth (around

equipment that workers would be contacting) are independently kept to safe levels, then the relative voltage difference between the two is also safe. This approach to limiting absolute potentials is the basis behind present MSHA requirements for a separate safety ground bed with a low measured resistance, and it is certainly effective when it is properly implemented. However, implementation can be extremely expensive for many mine operators, while for some it is physically impossible. A further difficulty is that the measurements necessary to properly assess the safety of the system may be impossible to make.

The goal of the work reported here is to demonstrate that the very conditions which make it difficult to measure ground bed resistance for some mines also make it unnecessary to design for low absolute potentials, since the relative potentials (which are the direct cause of a shock hazard) are reduced by these conditions. To demonstrate this, it is necessary to analyze touch and step potentials.

## 1.2 TOUCH AND STEP POTENTIALS

When the frame of a piece of equipment becomes energized, it poses a shock hazard to anyone who simultaneously contacts the equipment and any other conducting object not at the same potential. Since all other objects within the work area are normally at zero potential (earth potential), the full potential of the machine frame can appear across a worker's body (hand-to-hand or hand-to-foot). If the energized machine frame or other energized object is in direct electrical contact with the earth, then current will flow between the earth and the energized object through this contact. The resultant current flow in the earth perturbs the local earth potential, causing it to rise from zero toward the potential of the energized object. This perturbation affects the earth all around the energized object, and tends to elevate the potentials of other conducting objects in the vicinity that are in earth contact. The potential differences between the energized object, and surrounding objects in earth contact are, therefore, reduced to some degree, which makes it somewhat less dangerous for a worker who might come in simultaneous contact with the original energized object and a nearby object. It does, however, increase the hazard to anyone working in the area in simultaneous contact with objects other than the original object, since the objects have themselves developed potentials due to their earth contacts.

The voltage difference between an energized object and a point in the earth three feet away is defined as the "touch potential," and is assumed to represent the voltage difference from an employee's hand to feet when contacting energized objects. If the energized object is not in direct earth contact, then the earth near the object is assumed to be at zero potential, making the touch potential numerically equal to the potential of the energized object. If the object is in direct earth contact, local earth potentials are raised, so that the magnitude of the touch potential is reduced.

If the potential of the earth around an energized conducting object is perturbed by its direct electrical contact, then the earth is no longer an equipotential surface. A different voltage exists at every position on the

earth, depending on its distance from the energized object and other nearby conducting objects that may be in earth contact. Employees walking within this area of perturbed potential can experience significant voltage differences between their feet as they step from place to place. Thus, the potential difference between two points on the earth's surface three feet apart is called the "step potential." Since potential differences between nearby points become smaller as one gets further away from the source of the perturbation, step potentials are smaller than touch potentials. They do not exist at all unless the energized object is in direct electrical contact with the earth.

If a power system fault or lightning strike occurs that causes current to flow through the earth from a ground bed, then touch and step potentials will exist in the vicinity of the ground bed and any conducting structures electrically connected to the ground bed. The hazard severity of the shock hazard presented to mine personnel by these energized grounds depends on the magnitude of the touch potential produced and the likelihood that workers would contact the energized ground. Touch potential magnitude depends on the size of the energized grounded object which might be touched, how many other pieces of grounded equipment are in earth contact, and the resistance to earth of the ground system. The likelihood of contact depends on the number and nature of the energized equipment frames that workers might touch.

#### 1.2.1 Potentials on Localized Ground Systems

Some mines have small and relatively simple ground systems. The ground bed consists of a few rods or a small mat. The grounded machines are small and few in number, and tend to be in poor contact with the earth. Under these conditions, the entire ground system can be approximated as a single ground bed in contact with the earth, all other contacts being unimportant to the measurements and calculations being made. For this arrangement, the traditional measurement approach used by the industry and Mine Safety and Health Administration (MSHA) gives a good estimate of safety.

This traditional approach is to measure the resistance to earth of the isolated ground bed. This measurement is done using a "fall-of-potential" technique with the current-return electrode placed at a distance from the bed at least five times the maximum diameter of the bed. (A detailed explanation of this technique can be found in [2] or [3].) If this resistance is acceptably low (less than 5 ohms is a figure used often; see reference [4]), then it is assumed that any current likely to flow to earth through the bed will not cause hazardous potentials to appear on the bed. If hazardous potentials do not appear on the bed, then the touch and step potentials to any object grounded to the bed cannot be hazardous. This approach is relatively straightforward and easy to implement. It is also conservative because it ignores the effects of all of the machine frames connected to the ground bed that may be in direct earth contact also. These additional contact points reduce the overall resistance of the ground below the measured value of the isolated ground bed. In addition, as explained earlier, the fact that the machine frame is in direct earth contact tends to reduce its associated touch potential.

Although one might be concerned that an unduly conservative approach to assessing ground system safety causes ground bed construction and maintenance costs to be higher than necessary, for small to moderately-sized ground systems the simplicity of the approach is probably more important than any savings of construction or maintenance costs.

It should be noted that the ground-bed resistance must be measured on an isolated ground bed, one that has been disconnected from the rest of the ground system. If the resistance measurement procedure is carried out without disconnecting the bed, then erroneously low resistance readings are likely to result. Since the method itself is conservative, safety estimates based on such improper readings usually do not grossly underestimate the possible hazard, but under some common conditions a serious hazard could go undetected.

### 1.2.2 Potentials on Large Interconnected Ground Systems

If the mine ground system is large or involves ground connections to equipment in direct contact with the earth that are either physically large or make good electrical contact with the earth, the traditional approach of measuring isolated ground-bed resistance does not provide a meaningful estimate of ground system safety. There are several reasons why this approach is unsatisfactory.

First, if the ground bed itself is physically large, its resistance cannot be measured accurately. A reasonably accurate measurement of isolated bed resistance requires a return-electrode spacing of five times the maximum diameter of the bed. If the ground field (ground bed) is the support pad for a large mill or preparation plant, for instance, electrode spacings of thousands of feet might be necessary. It is seldom practical to make measurements at such large spacings.

Second, a large interconnected ground field is difficult to isolate for the purpose of making a resistance measurement. Points of interconnection with other objects may be unknown or inaccessible. If even one interconnection remains to a bed that is believed to be isolated, the resistance measurement becomes meaningless. While it is true that interconnections cause the resistance measurement to be conservative when the connected earth contacts are far away from the area of measurement, systems that contain interconnections to nearby or very large earth contacts can cause readings that underestimate ground system resistance, and hence lead to erroneously optimistic estimates of safety. Even if all hard-wired interconnections are located and removed, other large conducting structures nearby can still greatly affect the measurement of ground bed resistance. Such structures as railroad tracks, pipelines, belt conveyors, reinforced concrete shaft liners, and building foundations can couple portions of a ground system together even when there is no hard-wired interconnection. Meaningful measurements of resistance become impossible under such conditions.

Third, even when two objects have the same resistance to earth (and hence are energized to the same voltage level by a fault), touch potentials around very large energized grounded objects are much smaller than touch potentials around small objects. Although the relationship between earth potentials and the shape of an energized grounded object is complex, it can be demonstrated that the distance from the object over which the perturbations extend is directly proportional to the size of the object. Thus, all other factors being constant, a 20-meter radius energized object will cause the same perturbation at ten meters as a two-meter radius object will cause at one meter. Since touch potential is defined as the potential between the energized object and the (perturbed) earth at a point one meter away, it is considerably safer to touch a large energized object in contact with the earth than a small one. Since the energized grounded object can vary from a small pump (effective radius of 20 cm) to a large mill (effective radius of 200 m), the effect of electrode size can be very significant.

In conclusion, it is very difficult to make a resistance measurement on a large ground bed. Further, since there are likely to be other connecting structures near enough to perturb potentials around the large structure, any resistance measurement made is likely to be grossly inaccurate. Still further, estimates of hazard based on simple calculations that do not take into account the size and distance to other grounded objects are meaningless. The traditional approach to estimating ground system safety simply does not work for large interconnected systems. A new approach is necessary.

## CHAPTER 2 - ASSESSMENT OF GROUND SYSTEM SAFETY

Several approaches were taken to determine present ground system safety with respect to the possible impact on safety of a new method for determining the effectiveness of ground systems in limiting touch and step potentials. An initial review of about 400 electrical accidents reported to the Mine Safety and Health Administration (MSHA) was carried out and ground-system related accidents were identified. These accidents were further reviewed to determine if each accident would have been prevented by detecting system inadequacies through present ground bed resistance measurement techniques and by a possible new approach. Finally, several general mine types were studied to see if the proposed new method could be applied under particular conditions.

### 2.1 REVIEW OF ELECTRICAL ACCIDENTS

The 405 accidents related to metal/non-metal mines in the WVU data base[5] were reviewed and all accidents relating to shock, ground faults, and phase-to-frame faults were classified according to their relevance to the present research. There are four categories: (1) those accidents in which the grounding system was inadequate due to excessive ground-bed resistance, (2) those in which the grounding system was inadequate due to excessive impedance in the electrical connection between the ground bed and electrical equipment, (3) those in which the grounding system was not intact, and (4) those in which some grounding system inadequacy possibly caused the accident.

The primary focus of this research was to find accidents in which the grounding system was inadequate due to excessive ground-bed resistance. The first category above contains these accidents. However, the measurement techniques being developed under this contract also test the electrical continuity between grounded equipment and the ground bed. The third category contains accidents which would be impacted by these measurements. The second category was created to emphasize the hazardous conditions which would not be detected by the measurement procedures. Finally, many accident descriptions are so sketchy that it cannot be determined with certainty if they would be impacted or not. These are in the fourth category. A list of all accidents which fall in each category is included in this report as Appendix A.

Appendix A shows that about two percent of the accidents and fatalities listed in the base could be related to an inadequate ground bed, while another two percent could be related to undetected open circuits in the ground system.

### 2.2 NO DIRECT MEASUREMENT PROCEEDURE

At present, there are no direct ways to safely assess the adequacy of the ground system under fault conditions. Any direct way would require that full-scale potentials be applied to faulted conductors and full-scale current be allowed to flow. Such a procedure would be extremely

disruptive and likely to damage some of the equipment being tested. In addition, if the system were to fail a test, the very condition of its failure could cause extreme hazards to test personnel and to other persons on the mine property. Finally, since such high-energy sources would be used for the test, catastrophic and costly equipment damage might result from any slight misapplication of the test procedure.

Because the staging of full-scale faults is too dangerous and expensive to carry out, a number of indirect ways have been developed to estimate ground system performance from indirect electrical measurement, which are inexpensive and safe to make. A very popular indirect approach is to estimate the performance of the ground bed by measuring the relationship between current flow and voltage developed on an isolated bed at relatively low voltages. This approach is called the fall-of-potential method.

### 2.3 FALL-OF-POTENTIAL RESISTANCE MEASUREMENT

The fall-of-potential method involves circulating current between the ground bed and a remote electrode and measuring the potential at several locations between another remote electrode and the ground bed. A characteristic curve is produced, from which the resistance of the ground bed can be estimated. It is known from experience that low-resistance beds have a good record of safety.

The remote current electrode is located at least five times the largest dimension of the ground bed away from the ground bed. A current generator is connected between the ground bed and the remote electrode and a small current is circulated between the two. A voltmeter is connected to the ground bed and a second electrode. A series of potential measurements is taken on a line directly between the ground bed and the remote current electrode as shown in Figure 2.1. The measurements are expressed as the resistance of the ground bed. The resistance measurements versus distance from the ground bed are plotted on a graph and produce a characteristic curve as shown in Figure 2.2. The resistance of the ground bed is determined to be the same as the resistance of the flattened portion of the characteristic curve or the value found at 61.8 [2] percent of the distance from the center of the ground bed to the return electrode.

In order to carry out the fall-of-potential procedure it is necessary to isolate the ground bed from the rest of the power system. The ground bed must be disconnected from all other grounded structures and from the source for which it provides the reference. While the power system is disconnected and the measurement procedure is in progress, production at the mine must cease. Electrical equipment at the mine cannot be safely operated while it is ungrounded. The procedure also takes a sizable amount of time, further increasing idle time in the pit while the measurements are being taken.

Any attempt to switch the mine safety ground system to a "temporary" ground bed while measuring the permanent bed represents a significant waste of safety-related resources. To maintain system safety while

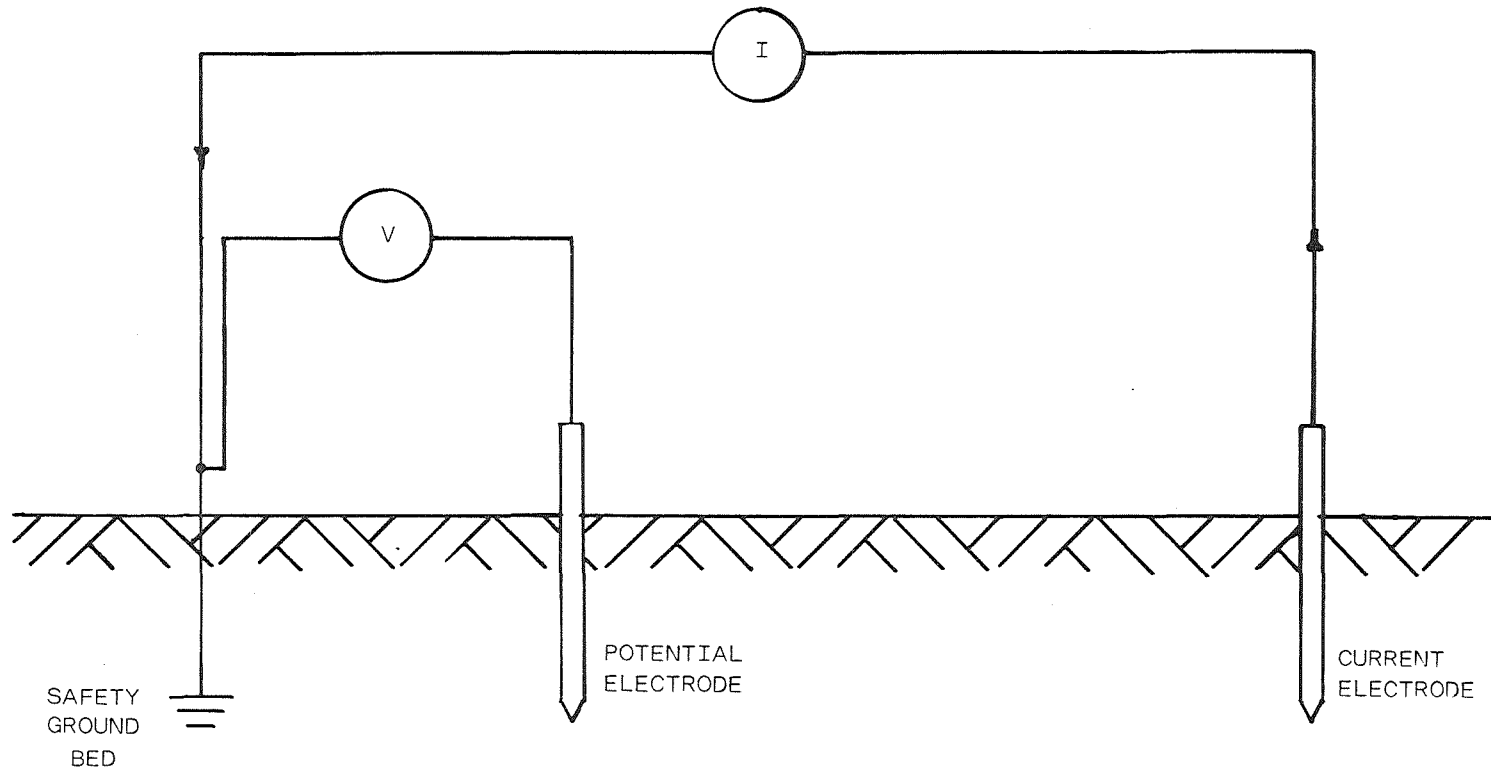

FIGURE 2.1 Fall-of-Potential Method

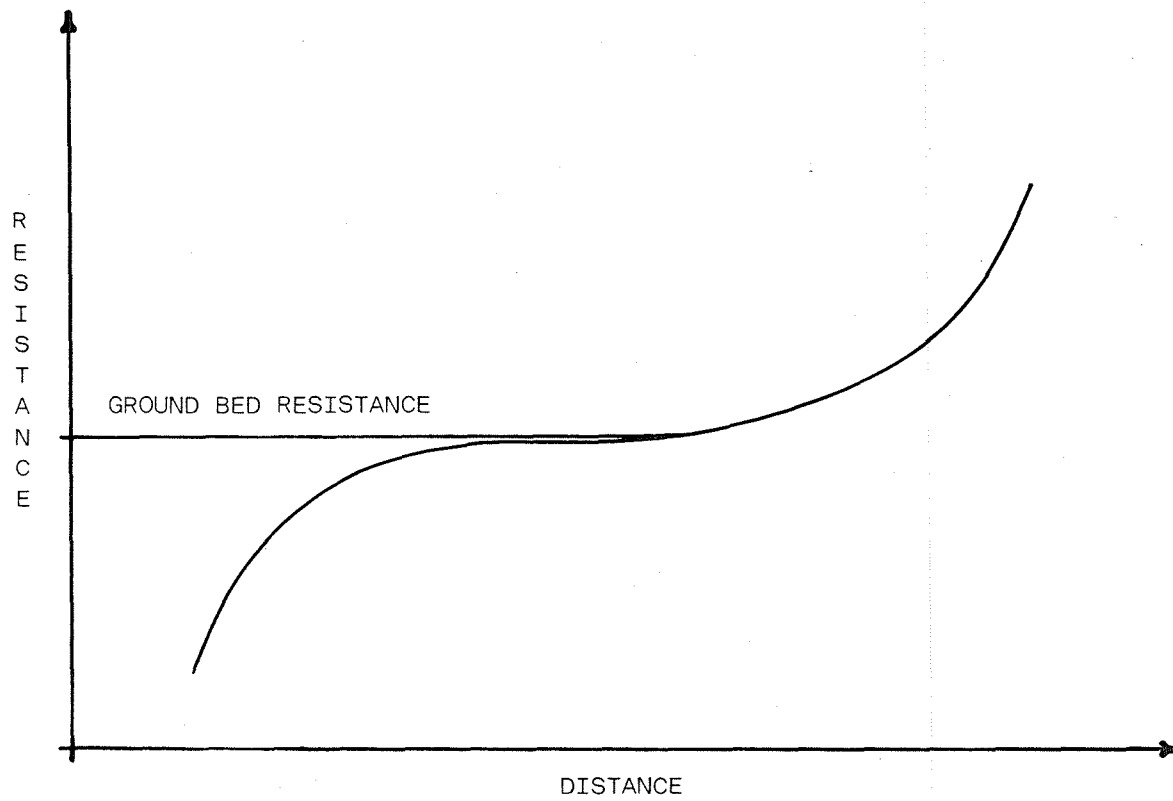

FIGURE 2.2 Fall-of-Potential Characteristic Curve

measurements are being made on the permanent bed, the temporary bed must also have an acceptably low resistance, and it must be located some distance from the permanent bed in order to prevent one bed from perturbing the measurements being made on the other. If such a temporary bed existed, then overall mine electrical safety could be greatly enhanced by keeping both beds connected in parallel at all times. The continual maintenance of a large bed without using it to improve day-to-day safety does not seem proper.

Finally, the resistance values obtained from the fall-of-potential measurement procedure are not necessarily related to the true safety of the grounding system. Any buried metal objects near the ground bed will affect the resistance measurements, possibly giving substantially lower resistance values than actually exist. This may lead to an overestimation of the ability of the grounding system to protect personnel from shock hazards. Estimates of safety based on bed resistance are not sensitive to how far away from the bed a fault might occur, what other conductors might be in the area, the effect of grounded equipment in contact with the earth at other places, and the size and shape of the ground bed itself. If the ground system is small and the ground bed resistance is low compared to equipment contact resistance, safety is correlated to resistance, and the fall-of-potential approach yields a good estimate of safety. For large or unusually shaped ground beds, or for systems with low-resistance connected equipment, such an approach may not accurately reflect the safety of the ground bed. Such a ground system should be evaluated by a procedure which is more sensitive to the factors which influence the shock hazard of a ground system.

#### 2.4 PROPOSED NEW METHOD

A new and more direct method has been developed to measure the effectiveness of ground beds at protecting personnel from shock hazards during ground faults. The method involves staging a small-scale ground fault and directly measuring the touch potentials that a person would experience.

The danger that exists to personnel in the vicinity of a ground fault is the touch potential that appears across a person when in contact with a piece of equipment. This touch potential is directly measured by staging a very small-scale ground fault with the current generator of a commercially available earth resistivity meter. The current generator is connected to the structure to be tested and to an electrode located where the ground fault would occur. A very small current is then circulated between the structure and the fault electrode. The voltmeter in the resistivity meter is connected to the structure and to an electrode located one meter from the structure (where a person would be standing when contacting the structure). The potential between the structure and the touch potential electrode is then measured and is expressed as a touch potential in volts per ampere of current flow. The impedance between the fault electrode and the equipment is then measured. For a fault of a given voltage, the fault current can be directly calculated by dividing the fault voltage by the fault impedance as measured above. The absolute touch potential is then calculated by multiplying the touch potential

measured above in volts/ampere by the calculated fault current. The measured touch potential gives a direct indication of the effectiveness of the grounding system.

This direct measurement procedure allows the mine to continue normal operations while the measurements are being conducted. The ground bed does not have to be disconnected. In fact, the ground bed should not be disconnected. This procedure measures the grounding system's effectiveness in its intact condition. The procedure also poses considerably less hazard for the personnel making the measurements and for the personnel working in the mine. No one is working on ungrounded equipment and no one is required to disconnect conductors which may be energized from the ground beds.

This measurement procedure evaluates the touch potentials that exist under actual fault conditions at the mine. The small-scale faults are staged where they would actually occur at the mine. The worst-case touch potential locations can be identified and examined. All effects of buried conductors, distributed ground beds, connected equipment, and non-homogeneous earth resistivities are accounted for in the measurement procedure, and do not have to be estimated.

## 2.5 STUDY OF ELECTRICAL SYSTEM DIAGRAMS

Four electrical system diagrams for metal/non-metal mines are provided in this section in Figures 2.3 through 2.6. These diagrams are of an open-pit metal mine, the surface facility of a uranium mine, a gypsum mine, and an underground salt mine. These mines were chosen by review of metal/non-metal mining operations of various types. Among the four, they represent the full range of situations under which traditional ground bed resistance measurements fail to provide convincing information on touch potential hazards. They were used initially to focus thinking on how to identify those areas around the mine most likely to have hazardous touch potentials and to develop a procedure for locating such areas in all types of mines.

The measurement procedure for the open-pit mine has been shown in the most detail, as it contains features which also apply to the other mines. Here the most severe shock hazard exists when a phase-to-earth fault occurs on an overhead feeder line into the pit. The mining machinery closest to the fault is subject to the worst touch and step potentials; the dragline shown in Figure 2.3[6] is typical. The measurement would be made of the worst-case voltage at the 'X' in the figure. This path is the shortest one from the machine to the fault.

One measurement problem associated with these hypothetical phase-to-earth faults concerns the minimum separation between the fault and the grounded equipment. The closer that the fault is postulated to occur, the more severe the potentials are. However, the limiting case of a phase-to-frame fault (when an overhead line actually falls on the machine) results in negligible current through the ground bed when the ground wire is intact. The touch potential in this case cannot be controlled by the grounding system, so that the phase-to-frame case is not a good test of

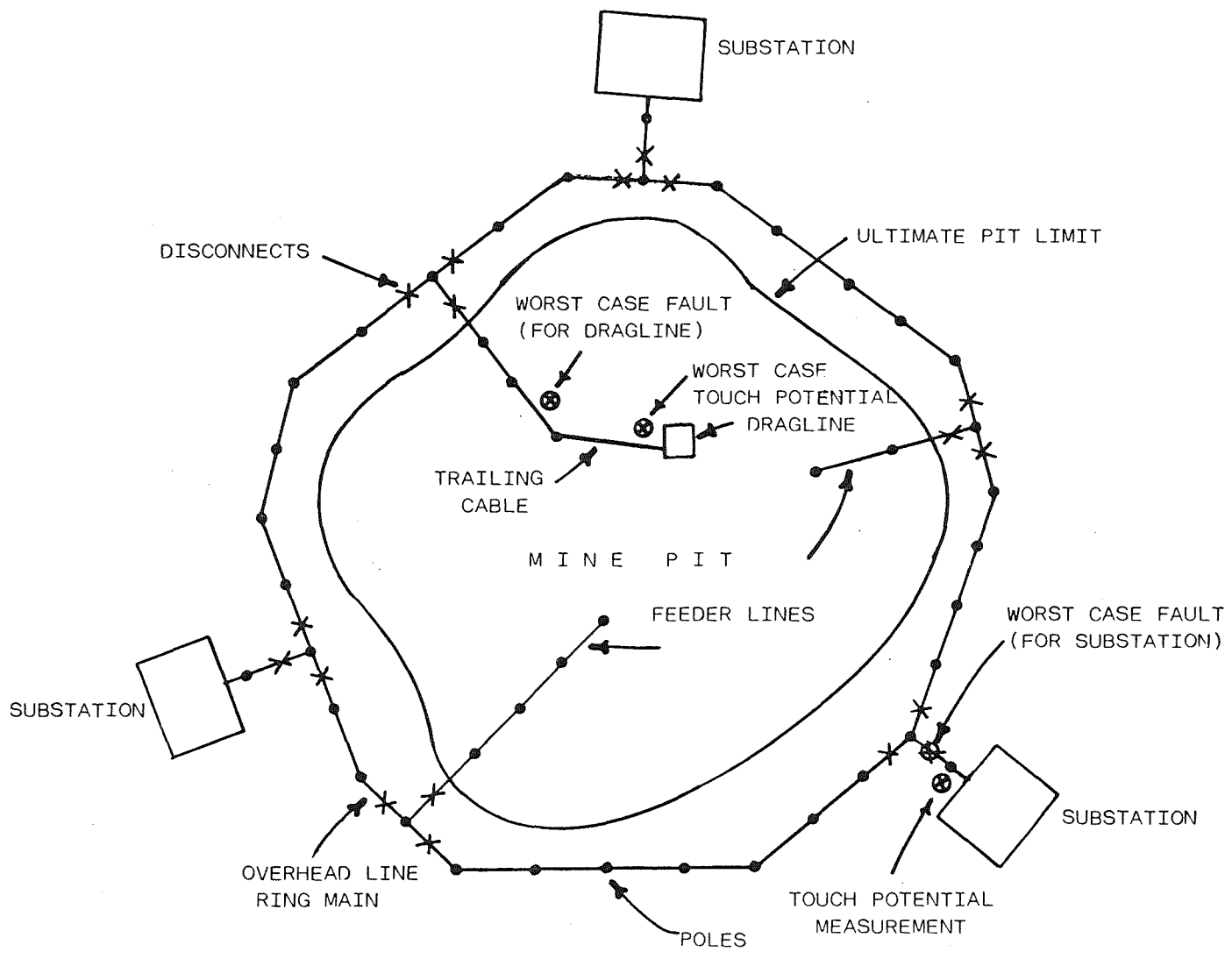

FIGURE 2.3 Open Pit Mine Electrical System[6]

that system. The approach taken was to assume a minimum separation between the machine and the fault, based on safe engineering practice for operating in the proximity of power lines. The separation problem is more severe for open-pit mines than for typical dredging operations.

Figure 2.4 shows the surface facility for a uranium mine. This is similar to some cement plants and other large surface facilities. Here an extensive surface grounding system interconnects the entire operation. Conventional earth-resistance measurements are useless here, as the current-return electrode cannot be located far enough away to make a reliable measurement. The techniques developed do not provide an immediate answer, either, as there are so many locations to measure touch potentials, each of which yielding a different number. The number of locations can be narrowed in three ways: (1) by making the measurements at the corners of the system, where the gradients are known to be the worst; (2) by choosing those corners closest to the power distribution system, where the likelihood of a fault is greatest; and (3) by picking from these locations the most heavily populated by workers.

The gypsum mine shown in Figure 2.5 is noteworthy because of its extensive conveyor system. Here the measurement technique would have to simulate a fault on the surface portion of the plant, and measure fault potentials on the two sections of the conveyor belt across the insulated section of the conveyor frame shown in the middle of the figure.

Figure 2.6 shows the extreme case of an unresolved measurement problem. Underground mines have a major portion of their electrical systems below the surface. Consequently, there is the possibility of a phase-to-earth fault underground. To realistically simulate these faults, the measurement procedures developed for these mines should involve underground measurements. Obviously, this would be more burdensome on the electrical inspector, and could be damaging to the measuring instrument.

For underground mining operations, there are two possible ground-fault mechanisms which generate shock hazards: (1) a fault close to the ground bed, which raises the potential of grounded equipment relative to the earth around the equipment, and (2) a fault close to grounded equipment, which raises the potential of the earth around the equipment relative to the equipment. The first mechanism causes no special problems for measurement, as the overwhelming majority of underground mines has a surface ground bed. The same procedures developed for surface mines can be used.

The second mechanism is more intractable: phase-to-earth faults can occur anywhere an energized conductor can touch the earth. For underground operations, this includes faults that occur underground and surface faults over shallow mines. To assess the hazards of these two types of faults, simulation of them is necessary. The underground fault can only be studied by carrying the resistance meter underground and injecting current at the hypothetical fault location. This was seen as a major problem, due to the inherent fragility of the instrument and the difficulty with driving measurement stakes in most mine floors. After examining this problem at great length, no way of avoiding the

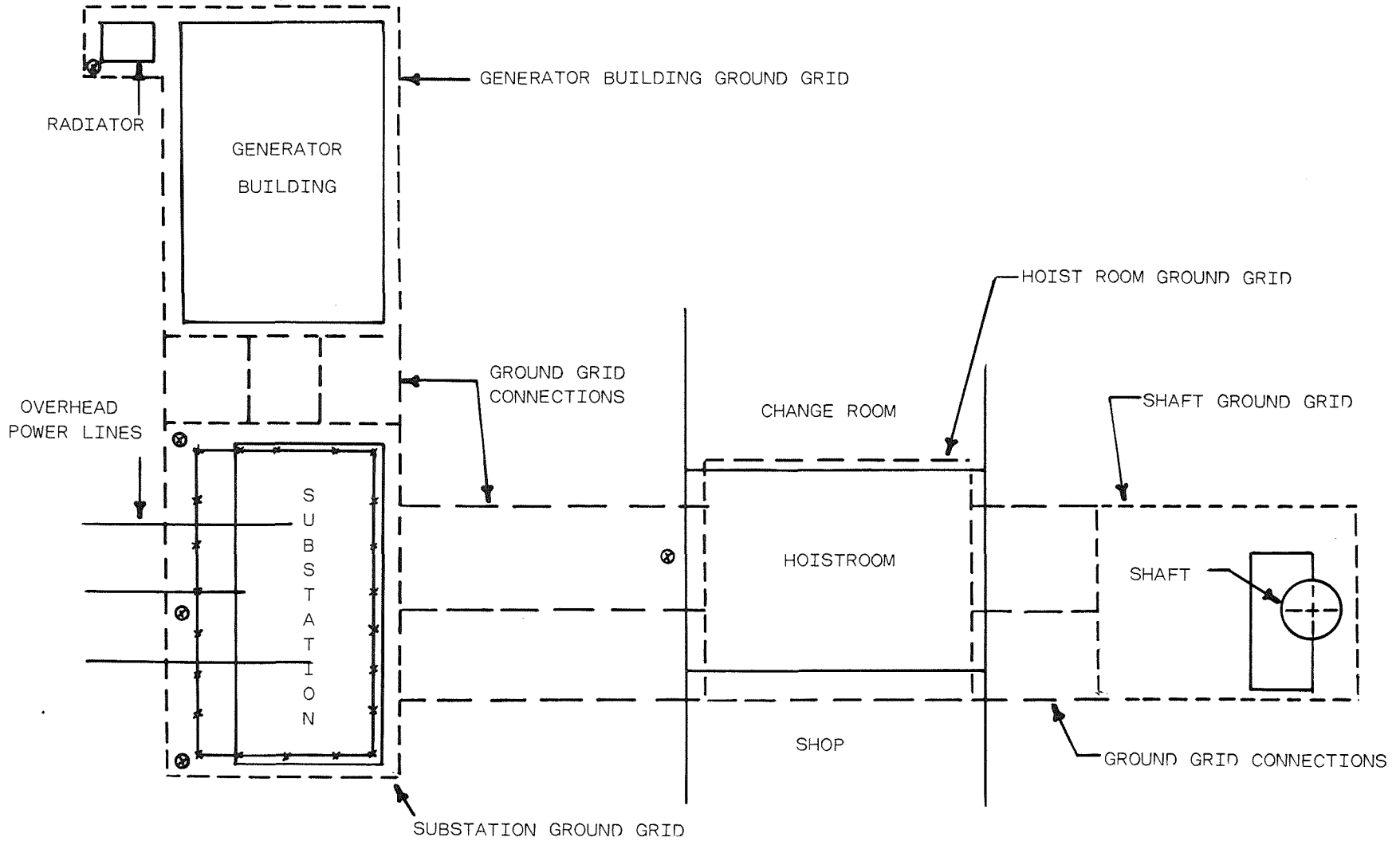

FIGURE 2.4 Uranium Mine Surface Facility

⊗ TOUCH POTENTIAL MEASUREMENT LOCATIONS

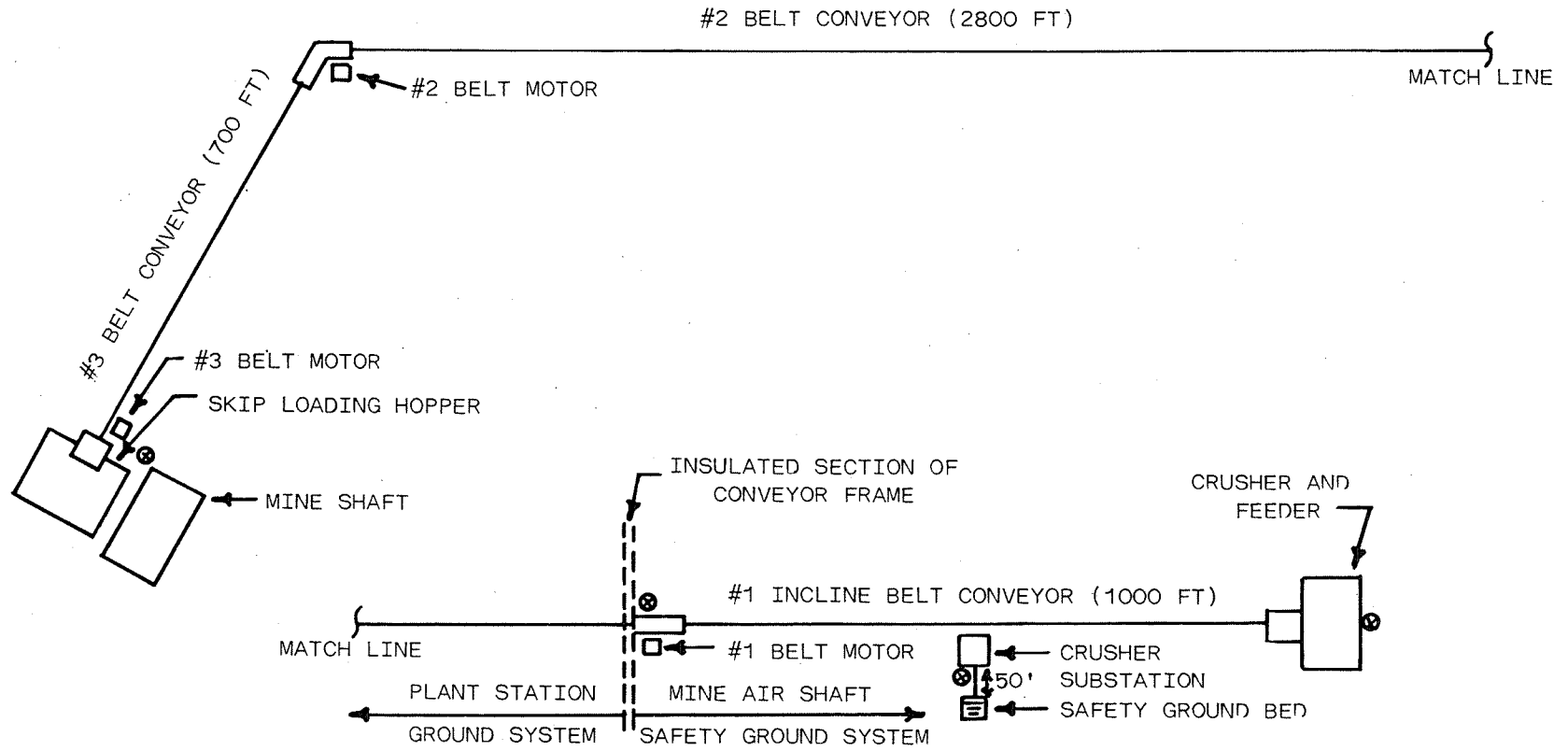
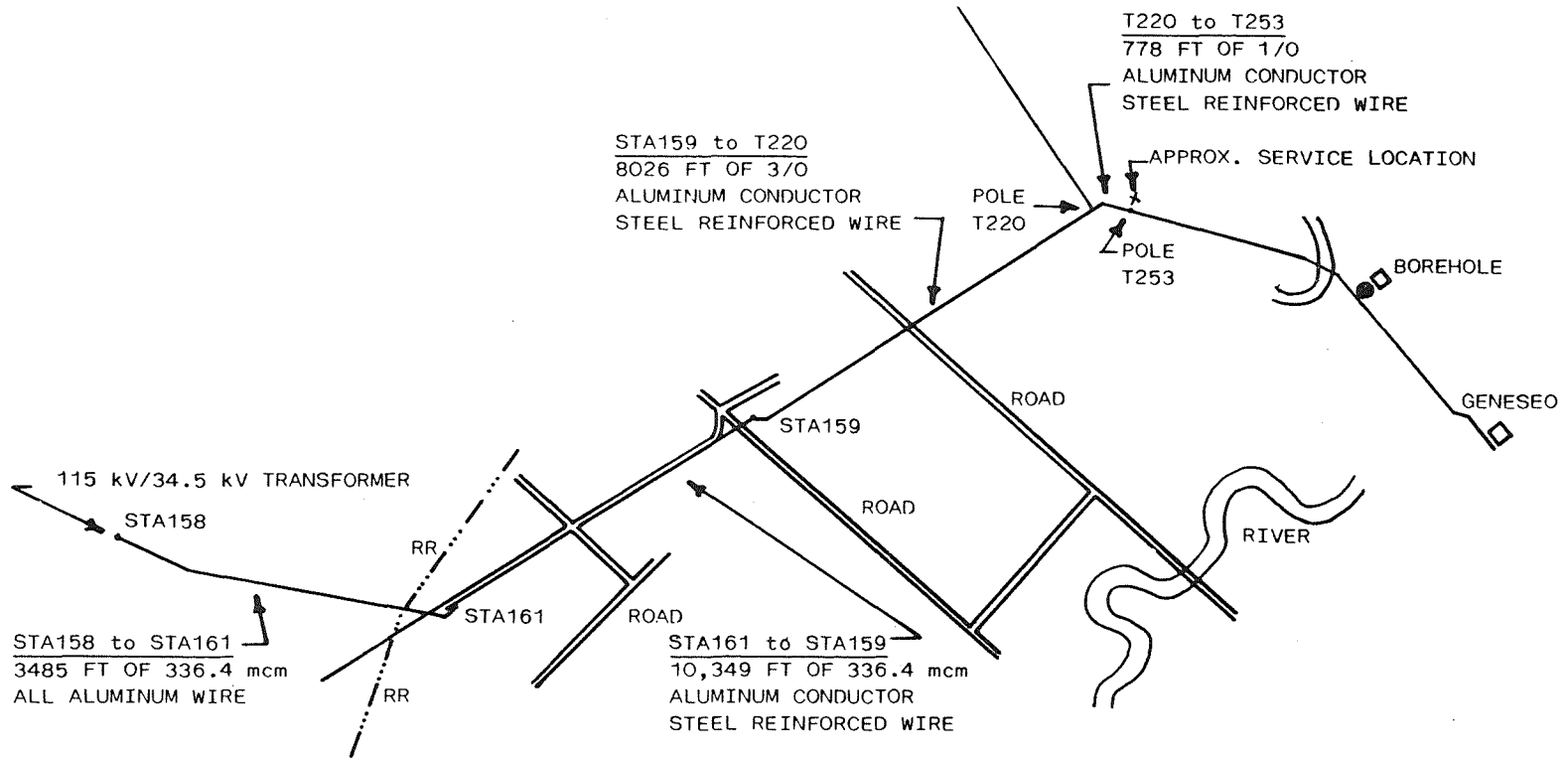

FIGURE 2.5 Gypsum Mine Conveyor System

⊗ TOUCH POTENTIAL MEASUREMENT LOCATIONS



⊗ TOUCH POTENTIAL MEASUREMENT LOCATIONS

FIGURE 2.6 Surface Electrical System for Underground Salt Mine

underground measurement was seen. The only encouraging factor here is the relative infrequency of phase-to-earth faults underground; the lack of exposed phase conductors (except for trolley wires) contributes significantly to this. Downed trolley wires tend to result in phase-to-neutral faults, as they contact the rails.

The last fault type, surface faults over underground mines, is even more of a measurement problem. The fault must be simulated on the surface, but the touch potentials measured underground. Because the fault simulation and touch-potential measurement are carried out with the same instrument, and both done simultaneously, this will be difficult. Fortunately, surface faults will cause underground shock hazards only in mines that are shallow. For example, a phase-to-earth fault on a 7200-volt system should not cause dangerous voltages underground if the mine depth is at least ten times the tunnel height.

As the result of these observations described above, the measurement procedure was developed for surface mines and surface areas of underground mines only, since it appeared that making underground measurements would require a much different procedure and totally different instrumentation.

### CHAPTER 3 - DEVELOPMENT OF TOUCH POTENTIAL EQUATIONS

The goal of the measurement procedure is to identify locations in the mine environment which have the highest touch potentials and then to determine the expected magnitude of the touch potentials under fault conditions. As part of this process, analytical expressions were derived for touch potentials for a variety of ground system geometries. These equations were based on solutions for hemispherical electrodes because these yield the simplest mathematical expressions. Many other shapes do not possess closed-form solutions or yield much more cumbersome expressions. Hemispherical electrodes were chosen because the clarity of the results offsets the lack of realism in carrying out calculations aimed at identifying possible hazardous locations.

#### 3.1 RESISTANCE OF HEMISPHERICAL ELECTRODES

For the purpose of this analysis the earth is modeled as a semi-infinite, homogeneous rectangular solid of constant resistivity. The rest of all space is filled sky, which is assumed to have an infinite resistivity. A hemispherical electrode is placed in the earth with its flat face coplanar with the boundary between earth and sky. With the assumption of homogeneous earth, spherical symmetry exists within the earth and current will flow radially outward in all directions from this electrode.[7]

For a given current,  $I$ , and earth resistivity,  $\rho$ , the current density at an arbitrary point  $s$  distance away from the center of the hemispherical electrode is found to be:

$$J = \frac{I}{2\pi s^2} \quad (3.1)$$

From the relation  $E = \rho J$ , the magnitude of the radial electric field at this point is:

$$E = \frac{\rho I}{2\pi s^2} \quad (3.2)$$

If the hemisphere is of radius  $r$ , the potential of the hemisphere with respect to infinity is found by integrating the electric field:

$$V = \int_r^{\infty} \frac{\rho I}{2\pi s^2} ds = \frac{\rho I}{2\pi} \int_r^{\infty} \frac{ds}{s^2} = \frac{\rho I}{2\pi r} \quad (3.3)$$

From Ohm's Law, the resistance of a single hemispherical electrode with respect to infinity is found as:

$$R_{\infty} = \frac{V}{I} = \frac{\rho}{2\pi r} \quad (3.4)$$

### 3.2 MUTUAL RESISTANCE OF HEMISPHERICAL ELECTRODES

A current flowing in an electrode causes a voltage to appear not only on that electrode but also on any other nonconnected electrode in contact with the earth. The existence of the second hemispherical electrode will disturb the spherical symmetry of the radial current flow. However, if the radius of the second electrode is small in comparison to the distance between the two electrodes, the perturbation is minimal and spherical symmetry can still be assumed. The potential induced on a second small hemispherical electrode with its center at a distance  $d$  from the center of the current carrying electrode is found to be:

$$V_d = \int_d^{\infty} \frac{\rho I}{2\pi s^2} ds = \frac{\rho}{2\pi d} \quad (3.5)$$

The voltage induced at the second electrode is directly proportional to the current carried by the first electrode. It then is convenient to define the "mutual resistance" between two electrodes as the voltage induced on the second electrode per ampere of current carried by the first electrode. For two hemispherical electrodes, their mutual resistance is:

$$R_{12} = \frac{V_d}{I} = \frac{\rho}{2\pi d} \quad (3.6)$$

The mutual resistance is reciprocal, so that  $R_{12} = R_{21}$ .

### 3.3 POTENTIALS APPEARING ON ELECTRODES DURING FAULTS

Figure 3.1 shows two hemispherical electrodes at points A and B near a ground fault occurring at point F. A current  $I_f$  is induced into the ground at the fault. The potentials appearing at the electrodes are:

$$V_a = I_f R_{af} = \frac{\rho I_f}{2\pi d_{af}} \quad (3.7)$$

$$V_b = I_f R_{bf} = \frac{\rho I_f}{2\pi d_{bf}} \quad (3.8)$$

where  $d_{af}$  and  $d_{bf}$  are the distances from the center of electrode A to the fault and the center of electrode B to the fault respectively.  $R_{af}$  and  $R_{bf}$  are the mutual resistances of the electrodes with respect to the ground fault. The voltages induced by electrodes A and B are zero since neither electrode is carrying current.

Suppose a ground fault occurs at point F again except that the current returns from the ground through electrode A as shown in Figure 3.2. The potential appearing at an electrode is the algebraic sum of all the

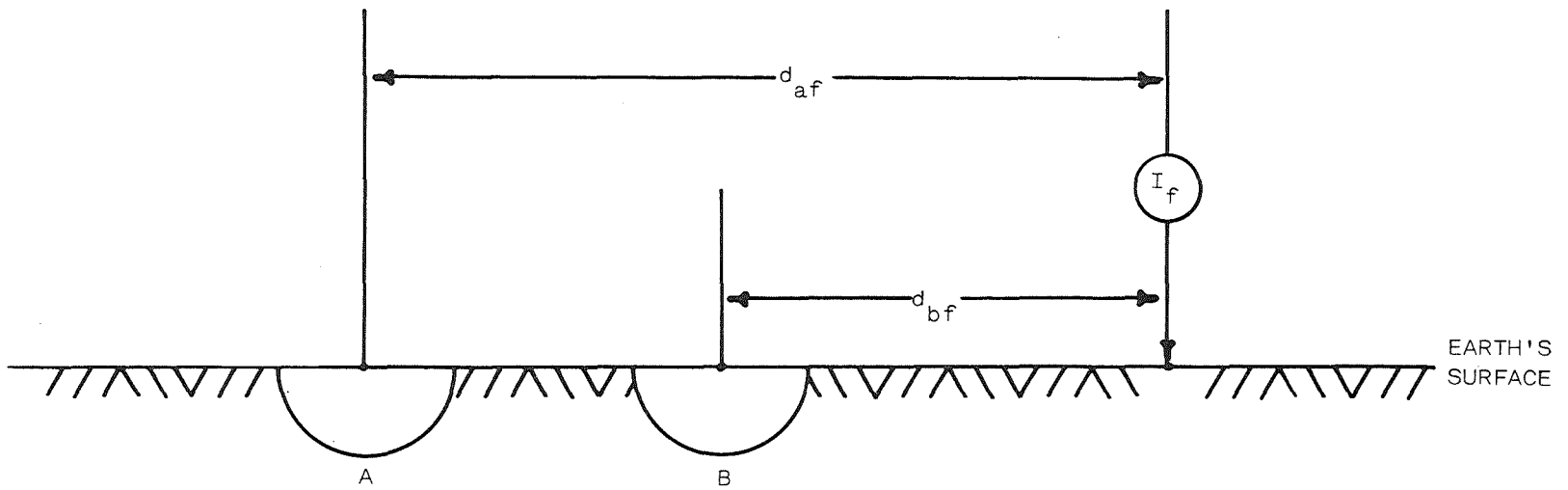

FIGURE 3.1 Ground Fault Near Two Hemispherical Electrodes

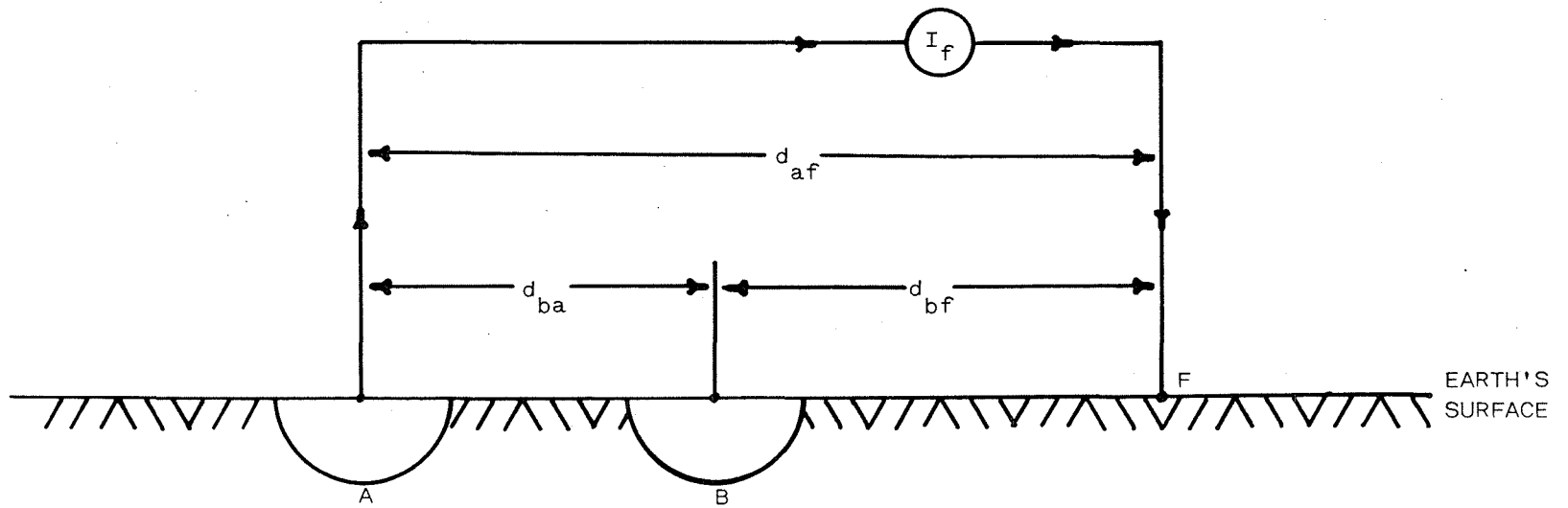

FIGURE 3.2 Ground FAult Near Two Hemispherical Electrodes with One Electrode Carrying the Fault Current

potentials induced at that electrode by all the currents entering and leaving the ground. In this case, the potentials appearing at the electrodes are:

$$V_a = I_f R_{af} - I_f R_a = I_f(R_{af} - R_a) = I_f \frac{\rho}{2\pi} \left( \frac{1}{d_{af}} - \frac{1}{r_a} \right) \quad (3.9)$$

$$V_b = I_f R_{bf} - I_f R_{ba} = I_f(R_{bf} - R_{ba}) = I_f \frac{\rho}{2\pi} \left( \frac{1}{d_{bf}} - \frac{1}{d_{ba}} \right) \quad (3.10)$$

$R_a$  is the resistance with respect to infinity of electrode A with radius  $r_a$ . Equation 3.3 indicates how to compute the resistance of such an electrode.

#### 3.4 EVALUATION OF VARIOUS TYPES OF PHASE-TO-EARTH FAULTS [8]

This section investigates all three ground fault conditions; single phase-to-earth, double phase-to-earth, and triple phase-to-earth faults, to determine which condition produces the worst case touch potentials.

A ground fault on a single phase of a balanced three-phase system will cause the system to become unbalanced. One method to analyze an unbalanced system is the Method of Fortesque. This method states that an unbalanced system of  $n$  related phasors can be resolved into  $n$  systems of balanced phasors called "symmetrical components" of the original phasors.

Three unbalanced phasors of a three-phase system can be resolved into three balanced systems of phasors as shown in Figure 3.3. The balanced sets of phasors are:

1. POSITIVE SEQUENCE COMPONENTS - three phasors equal in magnitude, 120 degrees apart with the same phase sequence as the original phasors.
2. NEGATIVE SEQUENCE COMPONENTS - three phasors equal in magnitude, 120 degrees apart with the opposite phase sequence of the original phasors.
3. ZERO SEQUENCE COMPONENTS - three phasors equal in magnitude, zero degrees apart.

The original unbalanced phasors are the sum of the symmetrical components.

$$V_a = V_{a1} + V_{a2} + V_{a0} \quad (3.11)$$

$$V_b = V_{b1} + V_{b2} + V_{b0} \quad (3.12)$$

$$V_c = V_{c1} + V_{c2} + V_{c0} \quad (3.13)$$

If one defines an operator,  $a$ , that causes a rotation 120 degrees in the counterclockwise direction, each of the symmetrical components of  $V_b$  and  $V_c$  can be expressed in terms of the symmetrical components of  $V_a$ .

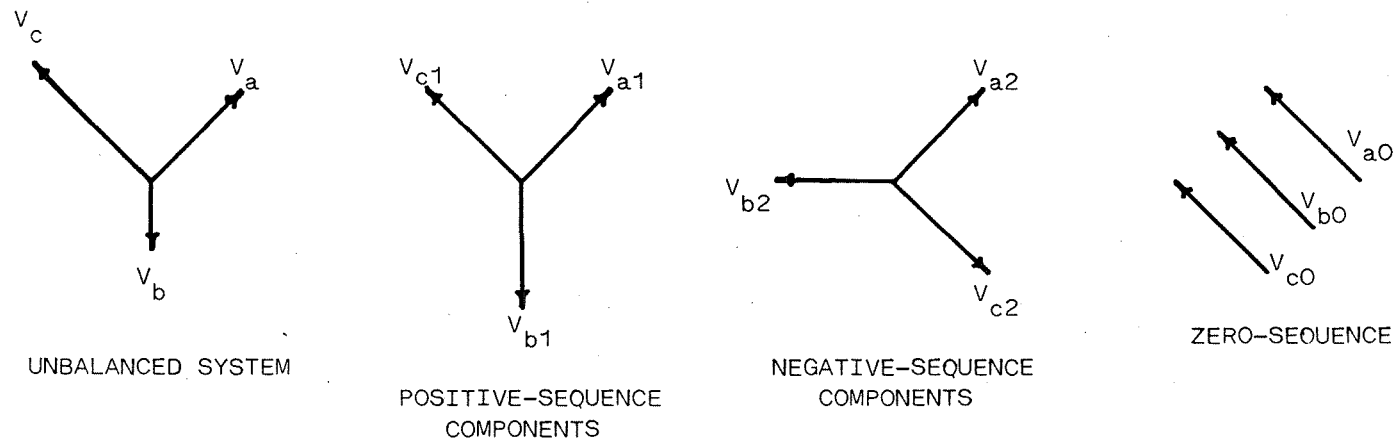

FIGURE 3.3 Symmetrical Components of an Unbalanced Three-Phase System

$$\begin{aligned}
 v_{b1} &= a^2 v_{a1} & v_{c1} &= a v_{a1} \\
 v_{b2} &= a v_{a2} & v_{c2} &= a^2 v_{a2} \\
 v_{b0} &= v_{a0} & v_{c0} &= v_{a0}
 \end{aligned}$$

Substituting these relations into Equations 3.12 and 3.13 leads to:

$$\begin{aligned}
 v_a &= v_{a1} + v_{a2} + v_{a0} = v_{a0} + v_{a1} + v_{a2} \\
 v_b &= a^2 v_{a1} + a v_{a2} + v_{a0} = v_{a0} + a^2 v_{a1} + a v_{a2} \\
 v_c &= a v_{a1} + a^2 v_{a2} + v_{a0} = v_{a0} + a v_{a1} + a^2 v_{a2}
 \end{aligned}$$

or

$$\begin{bmatrix} v_a \\ v_b \\ v_c \end{bmatrix} = \begin{bmatrix} 1 & 1 & 1 \\ 1 & a^2 & a \\ 1 & a & a^2 \end{bmatrix} \begin{bmatrix} v_{a0} \\ v_{a1} \\ v_{a2} \end{bmatrix} \quad (3.14)$$

Let

$$A = \begin{bmatrix} 1 & 1 & 1 \\ 1 & a^2 & a \\ 1 & a & a^2 \end{bmatrix}$$

Then

$$A^{-1} = (1/3) \begin{bmatrix} 1 & 1 & 1 \\ 1 & a & a^2 \\ 1 & a^2 & a \end{bmatrix}$$

Premultiplying both sides of Equation 3.14 by  $A^{-1}$  yields:

$$\begin{bmatrix} v_{a0} \\ v_{a1} \\ v_{a2} \end{bmatrix} = (1/3) \begin{bmatrix} 1 & 1 & 1 \\ 1 & a & a^2 \\ 1 & a^2 & a \end{bmatrix} \begin{bmatrix} v_a \\ v_b \\ v_c \end{bmatrix} \quad (3.15)$$

Likewise for currents:

$$\begin{bmatrix} I_{a0} \\ I_{a1} \\ I_{a2} \end{bmatrix} = (1/3) \begin{bmatrix} 1 & 1 & 1 \\ 1 & a & a^2 \\ 1 & a^2 & a \end{bmatrix} \begin{bmatrix} I_a \\ I_b \\ I_c \end{bmatrix} \quad (3.16)$$

In a three-phase system, the sum of the line currents is equal to the current in the return path through the neutral. Thus,

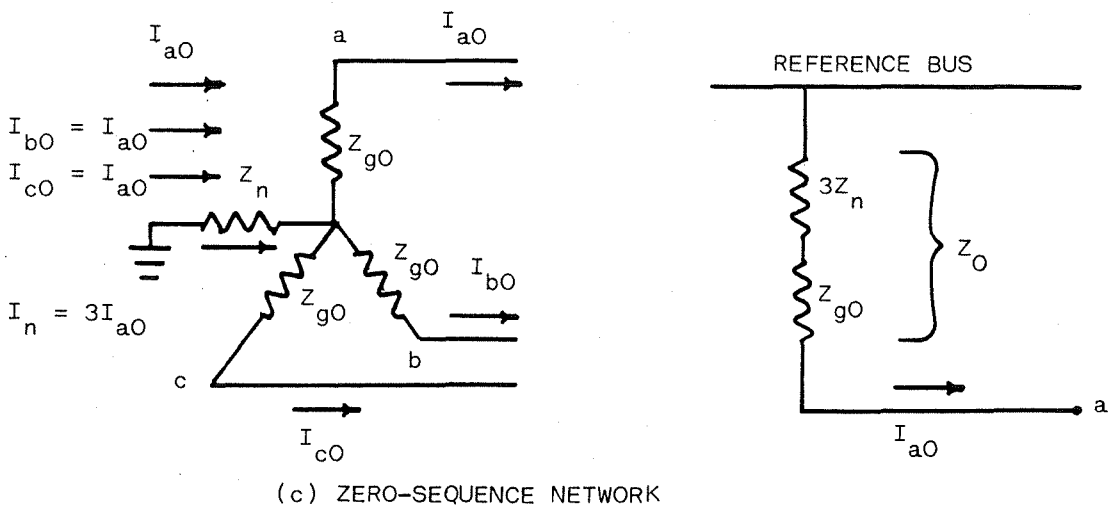
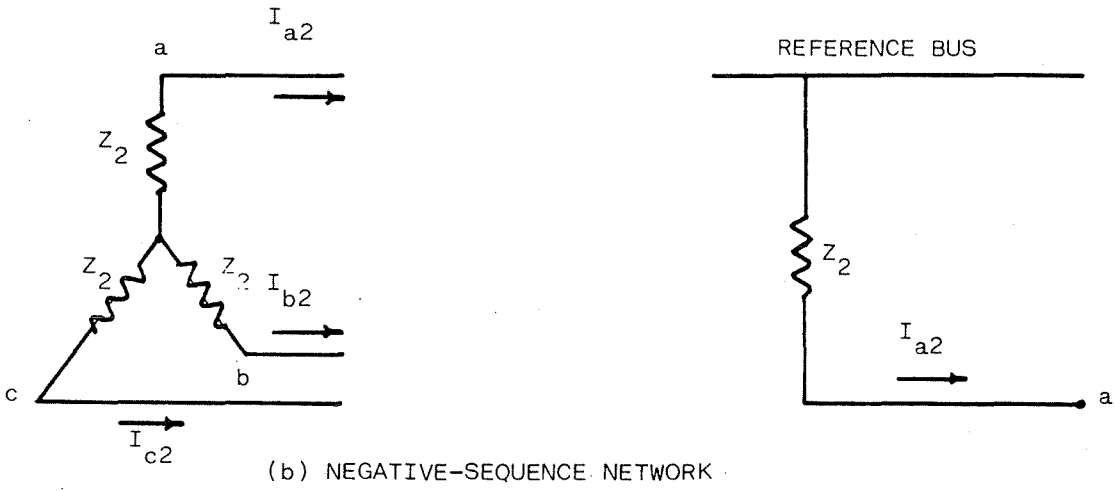
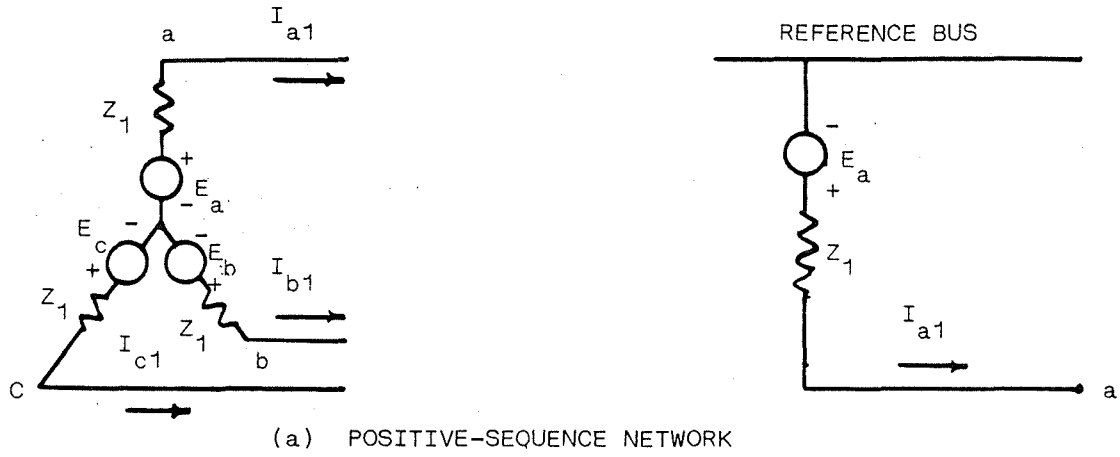

FIGURE 3.4 Sequence Networks for Three-Phase Systems

$$I_a + I_b + I_c = I_n \quad (3.17)$$

Comparing Equations 3.17 and 3.16 gives

$$I_n = 3I_{a0} \quad (3.18)$$

The sequence networks corresponding to the positive, negative, and zero-sequence components are illustrated in Figure 3.4. From these sequence networks, it can be seen that the sequence voltages and currents are related as shown in Equation 3.19.

$$\begin{bmatrix} V_{a0} \\ V_{a1} \\ V_{a2} \end{bmatrix} = \begin{bmatrix} 0 \\ E_a \\ 0 \end{bmatrix} - \begin{bmatrix} Z_0 & 0 & 0 \\ 0 & Z_1 & 0 \\ 0 & 0 & Z_2 \end{bmatrix} \begin{bmatrix} I_{a0} \\ I_{a1} \\ I_{a2} \end{bmatrix} \quad (3.19)$$

Where  $Z_0 = 3(Z_n) + Z_{g0}$ .

### 3.4.1 Single-Phase Fault

Figure 3.5 shows the conditions at a single phase-to-ground fault. Since  $I_b$  and  $I_c$  are equal to zero, Equation 3.16 becomes:

$$\begin{bmatrix} I_{a0} \\ I_{a1} \\ I_{a2} \end{bmatrix} = (1/3) \begin{bmatrix} 1 & 1 & 1 \\ 1 & a & a^2 \\ 1 & a^2 & a \end{bmatrix} \begin{bmatrix} I_a \\ 0 \\ 0 \end{bmatrix}$$

This leads to the condition:

$$I_{a0} = I_{a1} = I_{a2} = \frac{I_a}{3} \quad (3.20)$$

Substituting  $I_{a1}$  for  $I_{a2}$  and  $I_{a0}$  in Equation 3.19 and premultiplying both sides by  $[1 \ 1 \ 1]$  gives:

$$V_{a0} + V_{a1} + V_{a2} = Z_0(I_{a1}) + E_a - Z_1(I_{a1}) - Z_2(I_{a1})$$

Since  $V_{a0} + V_{a1} + V_{a2} = V_a = 0$  ( $V_a$  grounded), and from Equation 3.19  $I_a = 3(I_{a1})$ , the fault current  $I_f = I_n = I_a$  is given in terms of the phase voltage and the sequence impedances.

$$I_f = 3(E_a)/(Z_1 + Z_2 + Z_0)$$

Knowing that  $Z_0 = 3(Z_n) + Z_{g0}$ , the fault current becomes:

$$I_f = 3(E_a)/(3(Z_n) + Z_{g0} + Z_1 + Z_2)$$

For an unloaded circuit,  $Z_{g0}$ ,  $Z_1$ , and  $Z_2$  will be very small in relation to  $Z_n$ .

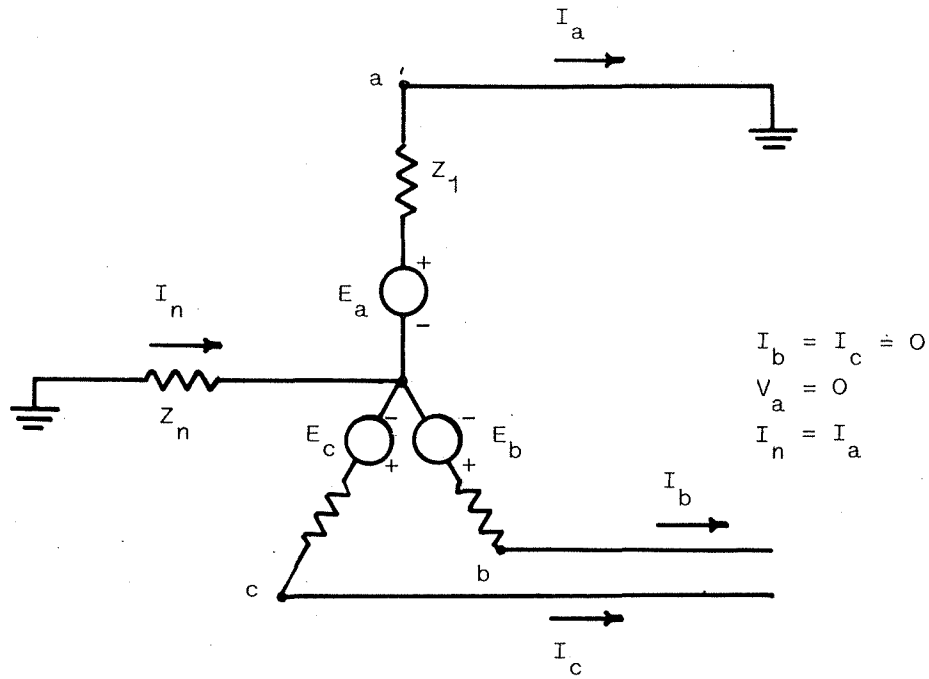

FIGURE 3.5 Single-Phase Ground Fault

So the equation for the fault current can be further simplified to:

$$I_f = 3(E_a)/3(Z_n) = E_a/Z_n \quad (3.21)$$

Equation 3.21 determines the fault current  $I_f$  in terms of the phase voltage  $E_a$  and the grounding impedance  $Z_n$ .

### 3.4.2 Double-Phase Fault

Figure 3.6 illustrates the conditions for a double phase-to-earth fault. Since  $V_b$  and  $V_c$  are zero, Equation 3.15 becomes:

$$\begin{bmatrix} V_{a0} \\ V_{a1} \\ V_{a2} \end{bmatrix} = (1/3) \begin{bmatrix} 1 & 1 & 1 \\ 1 & a & a^2 \\ 1 & a^2 & a \end{bmatrix} \begin{bmatrix} V_a \\ 0 \\ 0 \end{bmatrix}$$

This leads to:

$$V_{a1} = V_{a2} = V_{a0} = V_a/3 \quad (3.22)$$

Substituting  $(E_a - I_{a1}(Z_1))$  for  $V_{a1}$ ,  $V_{a2}$ , and  $V_{a0}$  in Equation 3.19 and pre-multiplying both sides of the equation by  $Z^{-1}$  where

$$Z^{-1} = \begin{bmatrix} Z_0 & 0 & 0 \\ 0 & Z_1 & 0 \\ 0 & 0 & Z_2 \end{bmatrix}^{-1} = \begin{bmatrix} 1/Z_0 & 0 & 0 \\ 0 & 1/Z_1 & 0 \\ 0 & 0 & 1/Z_2 \end{bmatrix}$$

gives

$$\begin{bmatrix} (E_a - I_{a1}(Z_1))/Z_0 \\ (E_a - I_{a1}(Z_1))/Z_1 \\ (E_a - I_{a1}(Z_1))/Z_2 \end{bmatrix} = \begin{bmatrix} 0 \\ E_a/Z_1 \\ 0 \end{bmatrix} - \begin{bmatrix} I_{a0} \\ I_{a1} \\ I_{a2} \end{bmatrix}$$

Pre-multiplying both sides of the equation by  $[1 \ 1 \ 1]$  and recognizing that  $I_{a1} + I_{a2} + I_{a0} = I_a = 0$ , gives the relationship

$$E_a(1/Z_0 + 1/Z_1 + 1/Z_2) - I_{a1}(1 + Z_1/Z_0 + Z_1/Z_2) = E_a/Z_1$$

This equation reduces to

$$I_{a1} = E_a / (Z_1 + (Z_0 Z_2) / (Z_0 + Z_2)) \quad (3.23)$$

From Equation 3.19  $V_{a1} = E_a - Z_1(I_{a1})$ . It is also known from Equation 3.22 that  $V_{a0} = V_{a1}$  and from Equation 3.19 that  $I_{a0} = -(V_{a0}/Z_0)$ . Substituting these relations into Equation 3.23 gives the zero-sequence current in terms of the phase voltage.

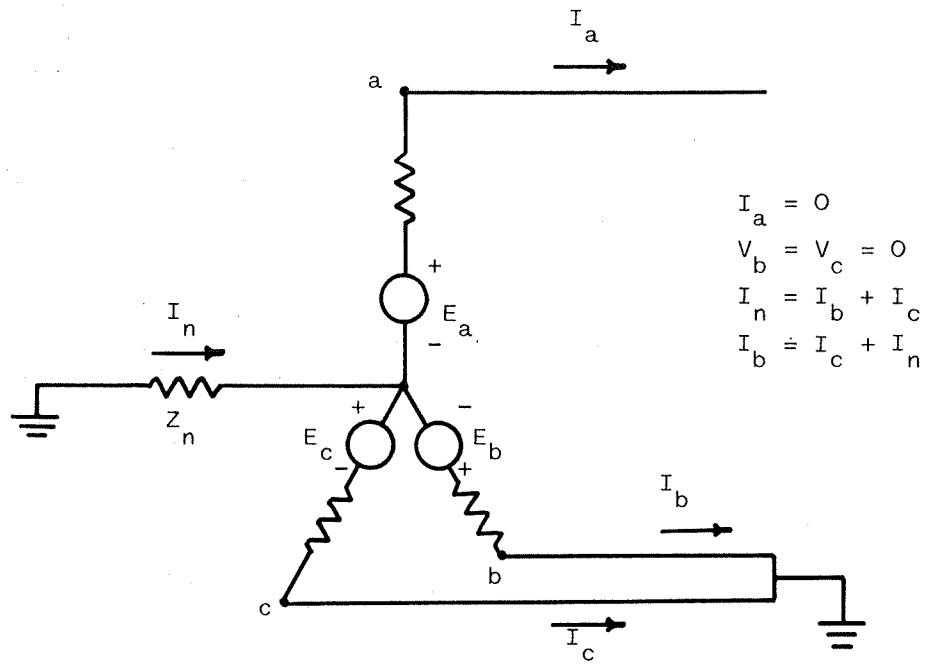

FIGURE 3.6 Double-Phase Ground Fault

$$I_{a0} = (E_a/Z_0)(Z_1/(Z_1 + (Z_0Z_2)/(Z_0+Z_2)))$$

The fault current is equal to  $I_b + I_c$ , which is equal to the neutral current  $I_n$ . From Equation 3.18 it is known that  $I_n = 3(I_{a0})$ . Therefore the fault current is given by Equation 3.24.

$$I_f = (3(E_a/Z_0)(Z_1/(Z_1 + (Z_0Z_2)/(Z_0 + Z_2)))) \quad (3.24)$$

The zero-sequence impedance  $Z_0$  in Equation 3.24 can be replaced by  $3(Z_n) + Z_{g0}$  (from Figure 3.4). Realizing that for an unloaded circuit  $Z_n$  will be much larger than either  $Z_{g0}$ ,  $Z_1$ , or  $Z_2$ , Equation 3.24 can be further reduced to Equation 3.25.

$$I_f = (E_a/Z_n)(-Z_2/(Z_1 + Z_2)) \quad (3.25)$$

Therefore, the fault current for the double-line fault is given by Equation 3.25.

### 3.4.3 Triple-Phase Fault

Figure 3.7 shows the conditions at a triple phase-to-earth fault. If all the phase impedances are equal, then this system is symmetrical. It can readily be seen that the fault current is equal to the neutral current  $I_n$  which is equal to the sum of the phase currents. Therefore,

$I_n = I_a + I_b + I_c$ . For a symmetrical, three-phase circuit,  $E_c = aE_a$  and  $E_b = a^2E_a$ . From Figure 3.7 it can be seen that the phase currents are given by:

$$I_c = E_a/Z_a$$

$$I_b = a^2(E_a/Z_a)$$

$$I_c = a(E_a/Z_a)$$

Summing these currents leads to an expression for the fault current.

$$I_f = I_n = (1 + a + a^2)E_a/Z_a$$

$$I_f = (1 + (-0.5 + j0.866) + (-0.5 - j0.866))E_a/Z_a$$

$$I_f = (1 - 1 + j0.866 - j0.866)E_a/Z_a$$

$$I_f = (0)E_a/Z_a = 0 \quad (3.26)$$

So, for a symmetrical triple phase-to-earth fault the fault current is given by Equation 3.26 and is zero!

### 3.4.4 Worst-Case Phase-to-Earth Fault

In summary, the fault current for a single phase-to-earth fault is

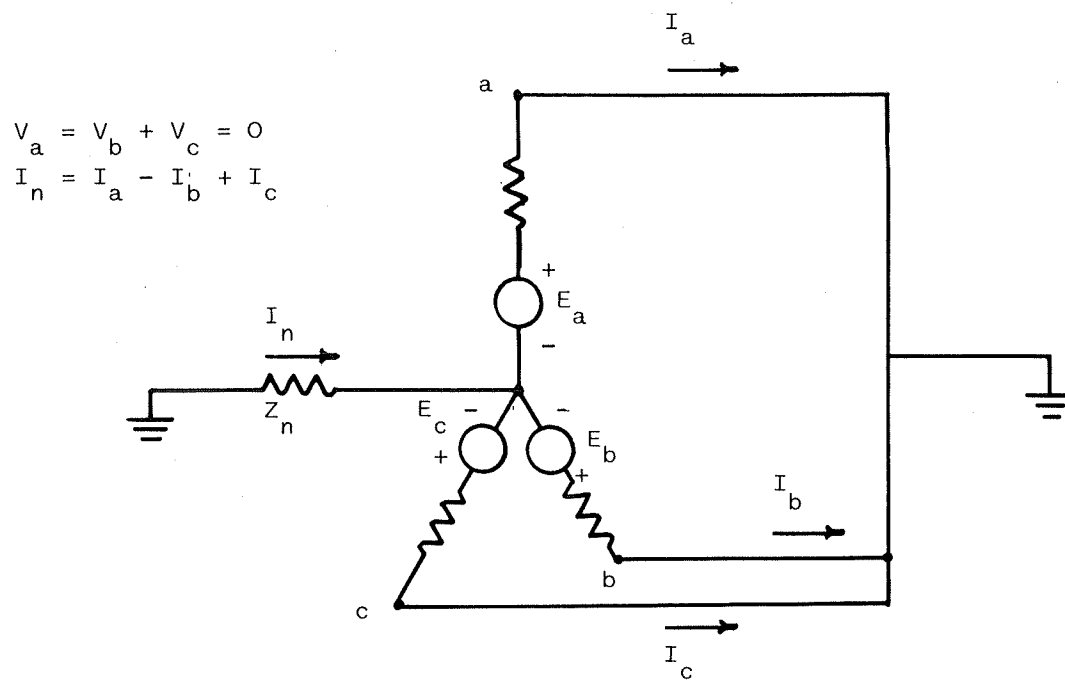

FIGURE 3.7 Triple-Phase Ground Fault

$$I_f = E_a / Z_n$$

The fault current for a double phase-to-earth fault is:

$$I_f = (E_a / Z_n) (-Z_2 / (Z_1 + Z_2))$$

the magnitude of which is less than the single phase-to-earth fault by a factor of  $Z_2 / (Z_1 + Z_2)$ . The fault current for a symmetrical triple phase-to-earth fault is

$$I_f = 0.$$

Fault current is identically zero only for a balanced three-phase system under perfectly symmetrical fault conditions -- a highly unlikely situation. The analysis does show, however, that triple faults produce relatively small net fault currents on the earth.

Therefore, it is concluded that the single phase-to-earth fault is indeed the worst-case fault condition, in terms of generating potentials on the ground system.

### 3.5 TOUCH POTENTIALS BETWEEN MAN AND MACHINE

Touch potential is defined as the potential that exists between a structure or machine that a person may touch and the earth at the person's feet. If the frame of the machine that the person could touch is energized, then a touch potential exists.

#### 3.5.1 No Ground Bed, Single-Hemisphere Machine

Figure 3.8 shows the situation of a ground fault near a machine. The contacts of the machine and fault with the earth are modeled as the hemispherical electrodes M and F respectively. Point E represents the furthest point from machine M that an employee can stand and still touch the machine. (Assumed to be three feet for the average person.) There is a ground system tying together the machine, the neutral of the source transformer, and the ground bed, but the effect of the ground bed on current distribution is being ignored in this case. All current is assumed to return through the machine.  $I_f$  is the fault current. The potentials that exist at the machine, the fault and the location of the employee are:

$$V_m = I_f R_{mf} - I_f R_m = I_f (R_{mf} - R_m) = I_f \frac{\rho}{2\pi} \left( \frac{1}{d_{mf}} - \frac{1}{r_m} \right) \quad (3.27)$$

$$V_f = I_f R_f - I_f R_{fm} = I_f (R_f - R_{fm}) = I_f \frac{\rho}{2\pi} \left( \frac{1}{r_f} - \frac{1}{d_{fm}} \right) \quad (3.28)$$

$$V_e = I_f R_{ef} - I_f R_{em} = I_f (R_{ef} - R_{em}) = I_f \frac{\rho}{2\pi} \left( \frac{1}{d_{ef}} - \frac{1}{d_{em}} \right) \quad (3.29)$$

The fault current  $I_f$  is not known directly for a given fault condition. What is known, however, is the phase voltage, the resistance of the grounding resistor and the earth resistivity. In Figure 3.9 the current

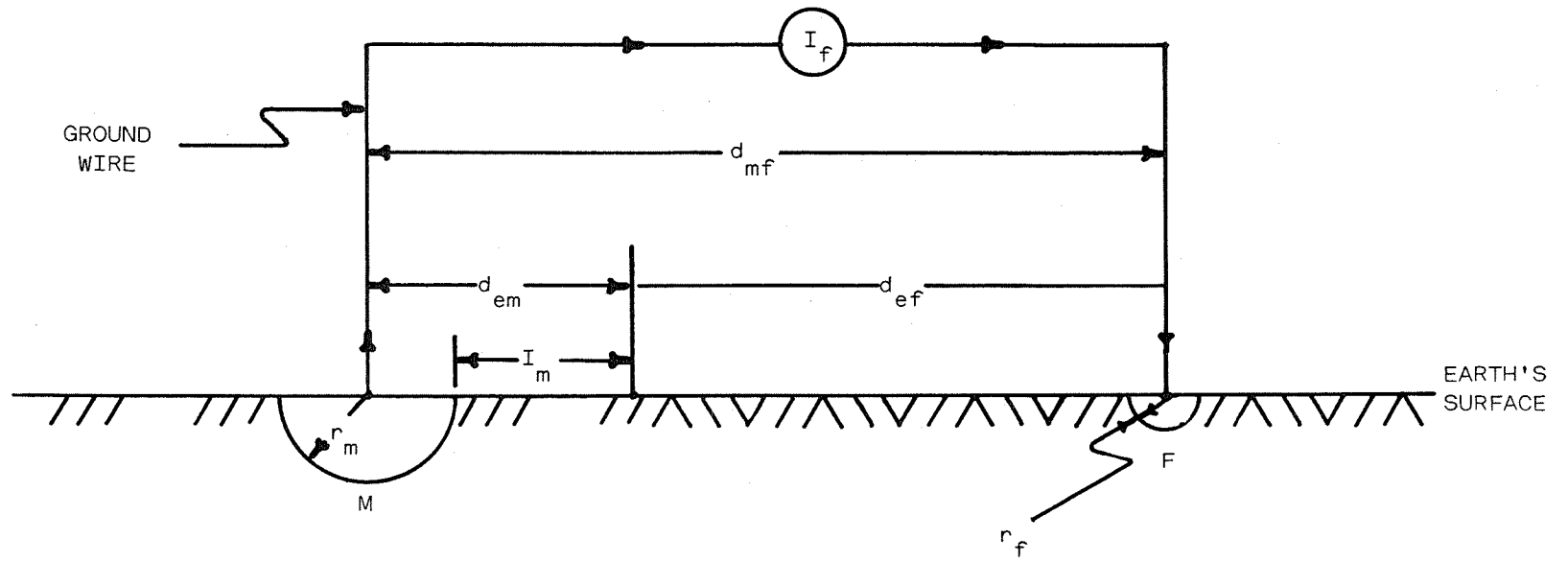

FIGURE 3.8 Touch Potential, Ground Fault Near Single-Hemisphere Machine

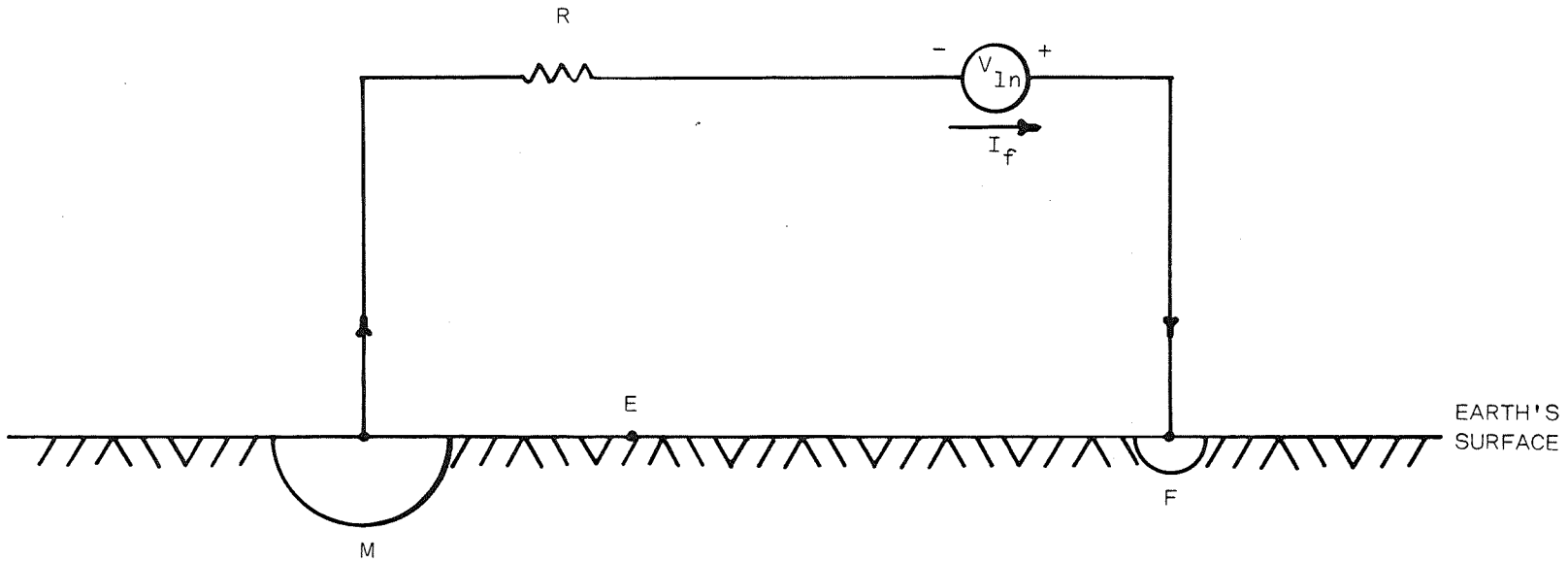

FIGURE 3.9 Ground Fault Showing Phase Voltage and Grounding Resistor

source  $I_f$  is replaced with a voltage source  $V_{ln}$  (line-to-neutral voltage)

in series with a grounding resistor  $R$ . The fault current, in terms of the line voltage is found to be:

$$\begin{aligned} V_m - I_f R + V_{ln} &= V_f \\ I_f R - I_f (R_{mf} - R_m) + I_f (R_f - R_{mf}) &= V_{ln} \\ I_f &= \frac{V_{ln}}{R + \frac{\rho}{2\pi} \left( \frac{1}{r_m} + \frac{1}{r_f} - \frac{2}{d_{mf}} \right)} \end{aligned} \quad (3.30)$$

So, now the potentials at the machine  $M$  and point  $E$  are:

$$V_m = \frac{\rho}{2\pi} \left( \frac{1}{d_{mf}} - \frac{1}{r_m} \right) \cdot \frac{V_{ln}}{R + \frac{\rho}{2\pi} \left( \frac{1}{r_m} + \frac{1}{r_f} - \frac{2}{d_{mf}} \right)} \quad (3.31)$$

$$V_e = \frac{\rho}{2\pi} \left( \frac{1}{d_{ef}} - \frac{1}{d_{em}} \right) \cdot \frac{V_{ln}}{R + \frac{\rho}{2\pi} \left( \frac{1}{r_m} + \frac{1}{r_f} - \frac{2}{d_{mf}} \right)} \quad (3.32)$$

The touch potential  $T$  between the machine and the employee is the difference between the two potentials.

$$T = V_e - V_m = \frac{\rho}{2\pi} \left( \frac{1}{d_{ef}} + \frac{1}{r_m} - \frac{1}{d_{em}} - \frac{1}{d_{mf}} \right) \frac{V_{ln}}{R + \frac{\rho}{2\pi} \left( \frac{1}{r_m} + \frac{1}{r_f} - \frac{2}{d_{mf}} \right)} \quad (3.33)$$

$$T = V_{ln} \cdot \frac{\frac{\rho}{2\pi} \left( \frac{1}{d_{ef}} + \frac{1}{r_m} - \frac{1}{d_{em}} - \frac{1}{d_{mf}} \right)}{R + \frac{\rho}{2\pi} \left( \frac{1}{r_m} + \frac{1}{r_f} - \frac{2}{d_{mf}} \right)} \quad (3.34)$$

### 3.5.2 With Ground Bed, Single-Hemisphere Machine

Figure 3.10 shows the situation where a ground fault occurs near a piece of machinery that is connected to a safety ground bed. Here, the ground bed is considered to have an effect on the current distribution. The fault and the machine are represented by hemispheres  $F$  and  $M$  respectively and the employee is represented by point  $E$ . The ground bed is represented by the hemisphere  $B$ . The fault current enters the earth at the fault electrode and returns through both the machine and the ground bed. The total fault current is the sum of the machine current and the ground bed current, or  $I_f = I_b + I_m$ . The potentials that exist at the ground bed, the machine, the employee and the fault are:

$$V_b = -I_b R_b - I_m R_{bm} + I_f R_{bf} \quad (3.35)$$

$$V_m = -I_b R_{mb} - I_m R_m + I_f R_{mf} \quad (3.36)$$

$$V_e = -I_b R_{eb} - I_m R_{em} + I_f R_{ef} \quad (3.37)$$

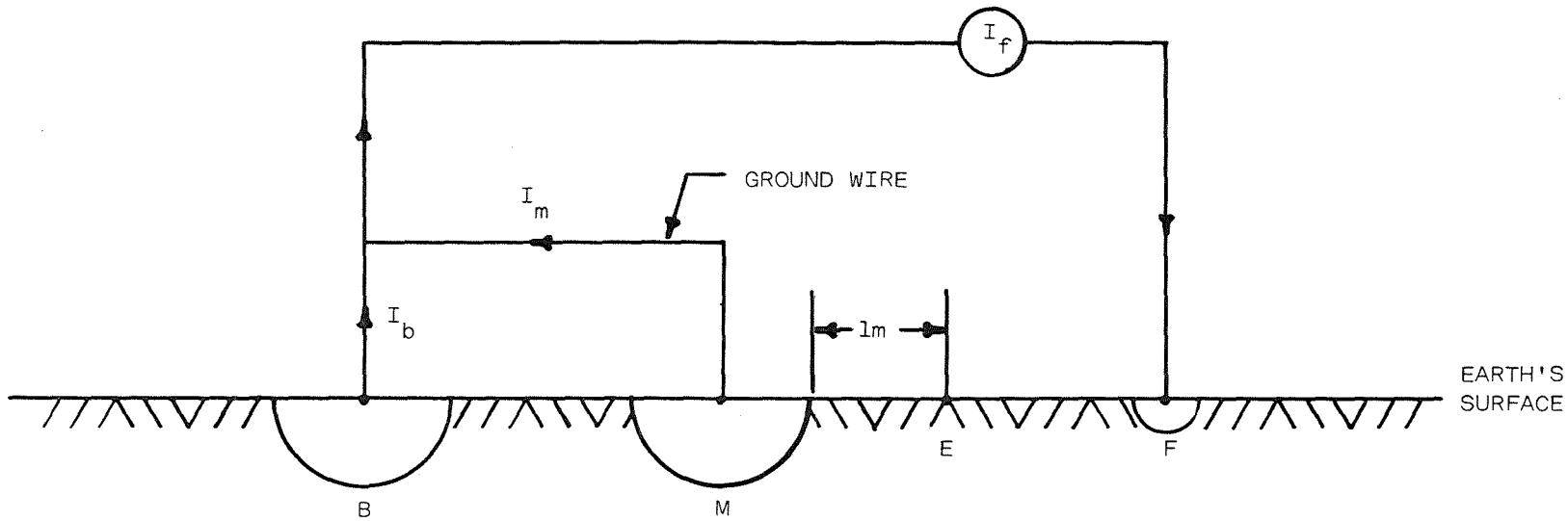

FIGURE 3.10 Ground Fault Near a Machine Connected to a Ground Bed

$$V_f = -I_b R_{fb} - I_m R_{fm} + I_f R_f \quad (3.38)$$

The machine current and the ground bed current can be expressed in terms of the fault current. Since the machine and the ground bed are tied together by a ground wire, their potentials are the same,  $V_m = V_b$ .

Noting that  $I_m = I_f - I_b$ , the ground bed current  $I_b$  is given by Equation 3.39.

$$\begin{aligned} V_b &= V_m \\ -I_b R_b - I_m R_{bm} + I_f R_{bf} &= -I_b R_{mb} - I_m R_m + I_f R_{mf} \\ -I_b R_b - (I_f - I_b) R_{bm} + I_f R_{bf} &= -I_b R_{mb} - (I_f - I_b) R_m + I_f R_{mf} \\ I_b (R_{bm} - R_b) + I_f (R_{bf} - R_{bm}) &= I_b (R_m - R_{mb}) + I_f (R_{mf} - R_m) \\ I_b (R_{bm} + R_{mb} - R_b - R_m) &= I_f (R_{mf} + R_{bm} - R_m - R_{bf}) \\ I_b &= I_f (R_m + R_{bf} - R_{mf} - R_{bm}) / (R_m + R_b - 2R_{mb}) \\ I_b &= I_f \frac{(\frac{1}{r_m} + \frac{1}{d_{bf}} - \frac{1}{d_{mf}} - \frac{1}{d_{bm}})}{(\frac{1}{r_m} + \frac{1}{r_b} - \frac{2}{d_{mf}})} \quad (3.39) \end{aligned}$$

Similarly, using the relation  $I_b = I_f - I_m$ , the machine current  $I_m$ , in terms of the fault current  $I_f$ , is found to be:

$$I_m = I_f \frac{(\frac{1}{r_b} + \frac{1}{d_{mf}} - \frac{1}{d_{mb}} - \frac{1}{d_{bf}})}{(\frac{1}{r_m} + \frac{1}{r_b} - \frac{2}{d_{mb}})} \quad (3.40)$$

As in the case of no ground bed (Section 3.5.1), the fault current is not known directly, but the line voltage of the fault and the resistance of the grounding resistor are known. If the current source  $I_f$  in Figure 3.10 is replaced by a voltage source  $V_{ln}$  and a resistor  $R$ , the fault current in terms of the line voltage is given by Equation 3.41.

$$\begin{aligned} V_b - I_f R + V_{ln} &= V_f \\ V_f - V_b + I_f R &= V_{ln} \\ -I_b R_{fb} - I_m R_{fm} + I_f R_f + I_b R_b + I_m R_{bm} - I_f R_{bf} + I_f R &= V_{ln} \\ I_b (R_b - R_{fb}) + I_m (R_{bm} - R_{fm}) + I_f (R + R_f - R_{bf}) &= V_{ln} \\ I_f \frac{[(R_b - R_{fb})(R_m + R_{bf} - R_{mf} - R_{bm}) + (R_{bm} - R_{fm})(R_b + R_{mf} - R_{mb} - R_{bf})]}{(R_m + R_b - 2R_{mb})} &+ \frac{(R_{bm} - R_{fm})(R_b + R_{mf} - R_{mb} - R_{bf})}{(R_m + R_b - 2R_{mb})} \\ + R + R_f - R_{bf} &= V_{ln} \end{aligned}$$

$$I_f = \frac{V_{ln}}{R + \frac{\rho}{2\pi} \left[ \frac{1}{r_f} - \frac{1}{d_{bf}} + \frac{(\frac{1}{r_b} - \frac{1}{d_{bf}})(D1) + (\frac{1}{d_{mb}} - \frac{1}{d_{fm}})(D2)}{(\frac{1}{r_m} + \frac{1}{r_b} - \frac{2}{d_{mb}})} \right]} \quad (3.41)$$

$$\text{where } D1 = \frac{1}{r_m} + \frac{1}{d_{bf}} - \frac{1}{d_{mf}} - \frac{1}{d_{mb}}$$

$$\text{and } D2 = \frac{1}{r_b} + \frac{1}{d_{mf}} - \frac{1}{d_{mb}} - \frac{1}{d_{bf}}$$

Substituting Equation 3.41 into Equations 3.39 and 3.40 gives the ground bed and the machine currents in terms of the line-to-neutral voltage of the ground fault. The touch potential can then be found as a function of the phase voltage in the ground fault.

$$\begin{aligned} T &= V_e - V_m \\ T &= I_b(R_{mb} - R_{eb}) + I_m(R_m - R_{em}) + I_f(R_{ef} - R_{mf}) \\ T &= I_f \left[ \frac{(R_{mb} - R_{eb})(R_m + R_{bf} - R_{mf} - R_{bm})}{(R_m + R_b - 2R_{mb})} \right. \\ &\quad \left. + \frac{(R_m - R_{em})(R_b + R_{mf} - R_{mb} - R_{bf})}{(R_m + R_b - 2R_{mb})} + R_{ef} - R_{mf} \right] \\ T &= V_{ln} \frac{\frac{\rho}{2\pi} \left[ \left( \frac{1}{d_{mb}} - \frac{1}{d_{fb}} \right)(D1) + \left( \frac{1}{r_m} - \frac{1}{d_{fm}} \right)(D2) + \frac{1}{d_{ef}} - \frac{1}{d_{mf}} \right]}{R + \frac{\rho}{2\pi} \left[ \frac{1}{r_f} - \frac{1}{d_{bf}} + \frac{(\frac{1}{r_b} - \frac{1}{d_{bf}})(D1) + (\frac{1}{d_{mb}} - \frac{1}{d_{fm}})(D2)}{(\frac{1}{r_m} + \frac{1}{r_b} - \frac{2}{d_{mb}})} \right]} \quad (3.42) \end{aligned}$$

where D1 and D2 have been defined previously.

Equation 3.42 gives the touch potential for the case of a single-hemisphere machine with a ground bed affecting the current distribution.

### 3.5.3 Double-Hemisphere Machine

A machine does not always have a symmetric contact area with the earth. Instead of a circular or a square contact the machine can have a rectangular or elongated contact area with the earth. One way to model this condition is to replace the single-hemisphere electrode model with a double-hemisphere electrode model. Figure 3.11 shows the machine modeled as two hemispherical electrodes connected to the ground bed by a common ground wire. If the two hemispheres of the machine are separated by a

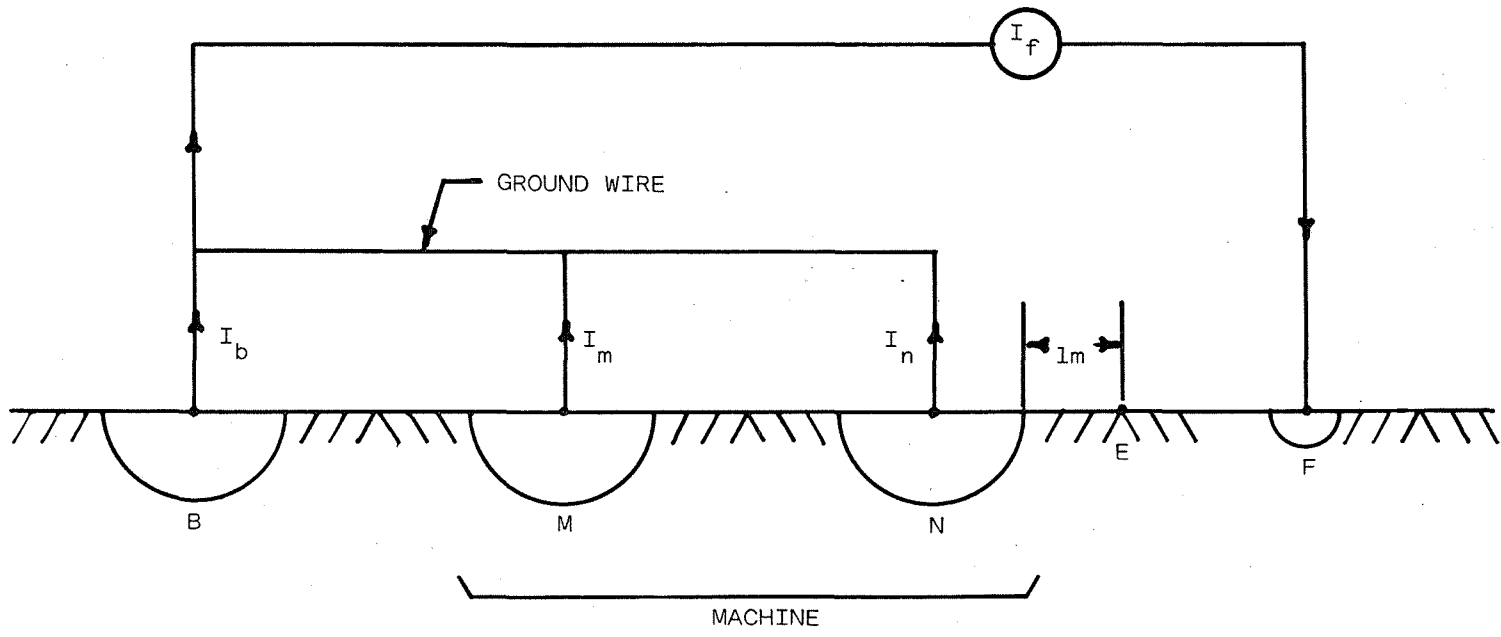

FIGURE 3.11 Machine Modeled with Two Hemispheres

distance at least five times greater than their radii, then neither hemisphere will appreciably alter the current field near the other. From Figure 3.11 it is seen that  $I_f = I_b + I_m + I_n$ , where M and N are the two hemispheres of the machine and  $I_m$  and  $I_n$  are the currents carried by those hemispheres, then the potentials appearing at the electrodes are:

$$V_b = -I_b R_b - I_m R_{bm} - I_n R_{bn} + I_f R_{bf} \quad (3.43)$$

$$V_m = -I_b R_{mb} - I_m R_m - I_n R_{mn} + I_f R_{mf} \quad (3.44)$$

$$V_n = -I_b R_{nb} - I_m R_{nm} - I_n R_n + I_f R_{nf} \quad (3.45)$$

$$V_e = -I_b R_{eb} - I_m R_{em} - I_n R_{en} + I_f R_{ef} \quad (3.46)$$

$$V_f = -I_b R_{fb} - I_m R_{fm} - I_n R_{fn} + I_f R_f \quad (3.47)$$

Since  $I_b = I_f - I_m - I_n$ , the electrode potentials can be expressed in terms of the machine currents and  $I_f$  only. The equations for the electrode potentials are then:

$$V_b = I_m(R_b - R_{bm}) + I_n(R_b - R_{bn}) + I_f(R_{bf} - R_b) \quad (3.48)$$

$$V_m = I_m(R_{mb} - R_m) + I_n(R_{mb} - R_{mn}) + I_f(R_{mf} - R_{mb}) \quad (3.49)$$

$$V_n = I_m(R_{nb} - R_{nm}) + I_n(R_{nb} - R_n) + I_f(R_{nf} - R_{nb}) \quad (3.50)$$

$$V_e = I_m(R_{eb} - R_{em}) + I_n(R_{eb} - R_{en}) + I_f(R_{ef} - R_{eb}) \quad (3.51)$$

$$V_f = I_m(R_{fb} - R_{fm}) + I_n(R_{fb} - R_{fn}) + I_f(R_f - R_{fb}) \quad (3.52)$$

The ground bed electrode and the machine electrodes are at the same potential. Setting  $V_b$  equal to both  $V_m$  and  $V_n$  leads to the expression of the machine currents,  $I_m$  and  $I_n$ , in terms of the fault current  $I_f$ :

$$I_m = I_f \cdot \frac{\left[ R_b + R_{fm} - R_{bf} - R_{bm} + \frac{R_{bf} + R_{bn} - R_d - R_{fn}}{(R2)}(R1) \right]}{(R3) - \frac{(R1)^2}{R2}} \quad (3.53)$$

$$I_n = I_f \cdot \frac{\left[ R_b + R_{fn} - R_{bf} - R_{bm} + \frac{(R_{bf} + R_{bm} - R_b - R_{fm})(R1)}{(R2)} \right]}{(R2) - \frac{(R1)^2}{R3}} \quad (3.54)$$

where  $R1 = R_b + R_{mn} - R_{bm} - R_{bn}$

$$R2 = R_b + R_n - 2R_{bn}$$

and  $R3 = R_b + R_m - 2R_{bm}$

As with the single-hemisphere cases (Sections 3.5.1 and 3.5.2), the fault current is not known directly but the phase voltage is known. The current source in Figure 3.11 is replaced with a voltage source  $V_{In}$  and a

grounding resistor  $R$ . Summing the voltages in the loop from the ground bed to the ground fault leads to:

$$\begin{aligned} V_f - V_b + I_f R &= V_{ln} \\ I_m(R_{bf} + R_{bm} - R_b - R_{fm}) + I_n(R_{bf} + R_{bn} - R_b - R_{fn}) \\ + I_f(R + R_f + R_b - 2R_{bf}) &= V_{ln} \end{aligned} \quad (3.55)$$

If  $I_m/I_f$  in Equation 3.53 is defined as  $K_m$  and  $I_n/I_f$  in Equation 3.54 is defined as  $K_n$ , then the fault current, in terms of the phase voltage of the ground fault, is given by:

$$\begin{aligned} I_f = V_{ln} / [R + (R_f + R_b - 2R_{bf}) + K_m(R_{bf} + R_{bm} - R_b - R_{fm}) \\ + K_n(R_{bf} + R_{bn} - R_b - R_{fn})] \end{aligned} \quad (3.56)$$

Substituting Equation 3.56 into Equations 3.53 and 3.54 gives the machine currents,  $I_m$  and  $I_n$ , in terms of  $V_{ln}$  also. These relations are then substituted into Equations 3.49, 3.50 and 3.51 so that the potentials at the machine and the employee are given in terms of the phase voltage of the ground fault.

$$V_m = I_f [K_m(R_{bn} - R_{mn}) + K_n(R_{bm} - R_m) + R_{fm} - R_{bm}] \quad (3.57)$$

$$V_n = I_f [K_m(R_{bn} - R_n) + K_n(R_{bn} - R_{mn}) + R_{fn} - R_{bn}] \quad (3.58)$$

$$V_e = I_f [K_m(R_{eb} - R_{em}) + K_n(R_{eb} - R_{en}) + R_{ef} - R_{eb}] \quad (3.59)$$

Since  $V_m$  is equal to  $V_n$  (interconnected) the touch potential between the employee and the machine, for the case where the machine is modeled as two hemispherical electrodes, is given by either

$$T = V_e - V_m \quad (3.60)$$

or

$$T = V_e - V_n \quad (3.61)$$

where  $V_m$ ,  $V_n$  and  $V_e$  are given by Equations 3.57, 3.58 and 3.59 respectively.

### 3.5.4 Dual Current Sources, Single-Hemisphere Machine

When the radius of a hemispherical electrode is small in relation to the distances between it and other electrodes, it is accurate to assume that the current carried by the electrode leaves or enters the electrode at a point at the center of the flat surface of the hemisphere. If the radius of the electrode is comparable to the inter-electrode distances, then the electrode will appreciably alter the symmetry of the current field in its vicinity. More current will enter the electrode on the side nearest the current source. To more accurately model this condition,

current is assumed to leave or enter the hemisphere from two point sources; one placed at the center of the electrode and one off center, towards the external current source.

Figure 3.12 shows the situation where a machine is in the vicinity of a ground bed and a ground fault. Each is modeled as a hemispherical electrode and each is carrying current. The effect of  $I_b$  on the symmetry of the current field around the machine is handled by current sources located at points  $I_g$  and  $I_m$ . The effect of  $I_f$  on the current field is handled by current sources located at points  $I_h$  and  $I_m$ . Therefore, the machine has three current sources within it:  $I_g$  due to  $I_b$ ,  $I_h$  due to  $I_f$ , and  $I_m$ , which is the sum of current sources due to both  $I_b$  and  $I_f$ . The distance of a secondary current source from the center of the electrode is equal to the radius of the electrode squared divided by the distance from the center of the electrode to the external current source. For the machine electrode in Figure 3.12, the distances to the secondary sources from the center of the electrode are:

$$\text{for source } I_h: \quad d_{mh} = r_m^2/d_{mf} \quad (3.62)$$

$$\text{for source } I_{mb}: \quad d_{mg} = r_m^2/d_{mb} \quad (3.63)$$

The locations of the auxiliary sources are shown in Figure 3.13. They are located on the imaginary line connecting their respective source electrodes to the center of the machine electrode.

The magnitudes of the auxiliary current sources are a function of the distance and magnitudes of the external current sources. The magnitude of the auxiliary source is equal to the magnitude of its related external source multiplied by the ratio of the radius of the hemispherical electrode to the distance between the electrode and the external source. The direction of the current flow (into or out of the ground) is opposite to that of the external source. Referring to Figure 3.12, the magnitudes of the auxiliary current sources for this case are

$$I_h = (r_m/d_{mf}) \cdot I_f \quad (3.64)$$

$$I_g = -(r_m/d_{mb}) \cdot I_b \quad (3.65)$$

The negative sign in Equation 3.65 indicates that the current  $I_g$  is flowing in the opposite direction from which it has been defined in the figure. Since the current  $I_b$  is flowing out of the ground, the current  $I_g$  must flow into the ground to comply with the definition above. Hence,  $I_g$  is negative since it is shown to flow out of the ground in Figure 3.12.

The third current source in the machine electrode carries the remaining current load required to conserve the charge of the system. Therefore, the magnitude of  $I_m$  is equal to the algebraic sum of the other

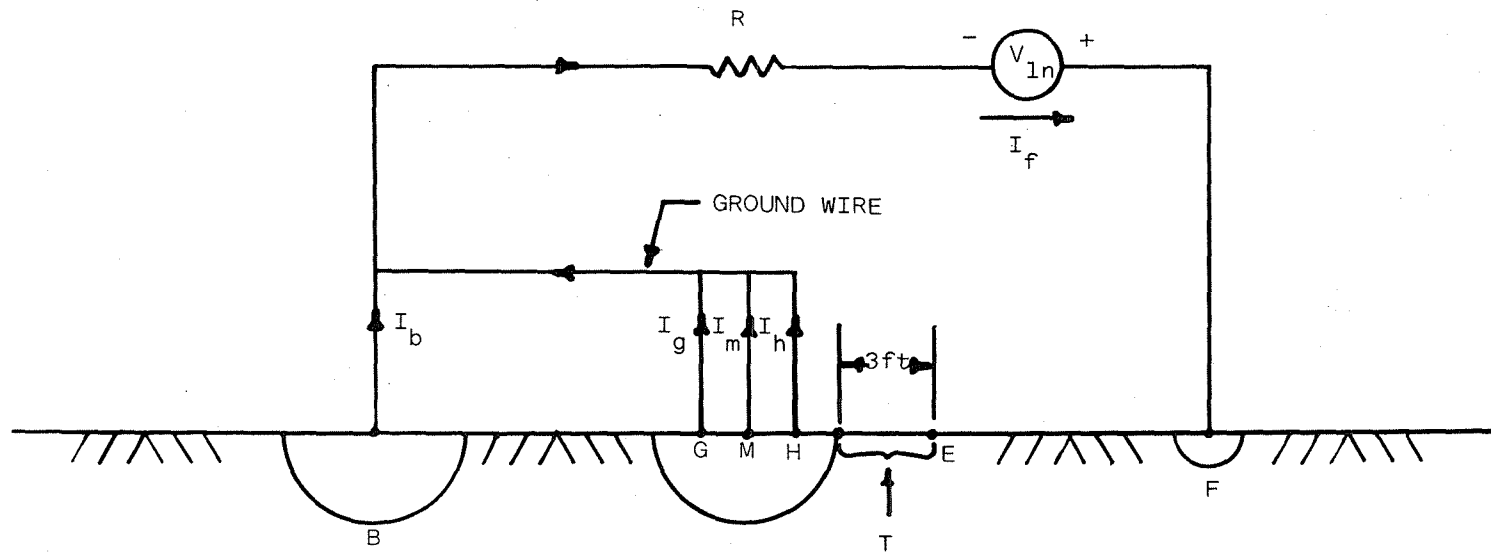

FIGURE 3.12 Dual Current Sources in the Machine Electrode

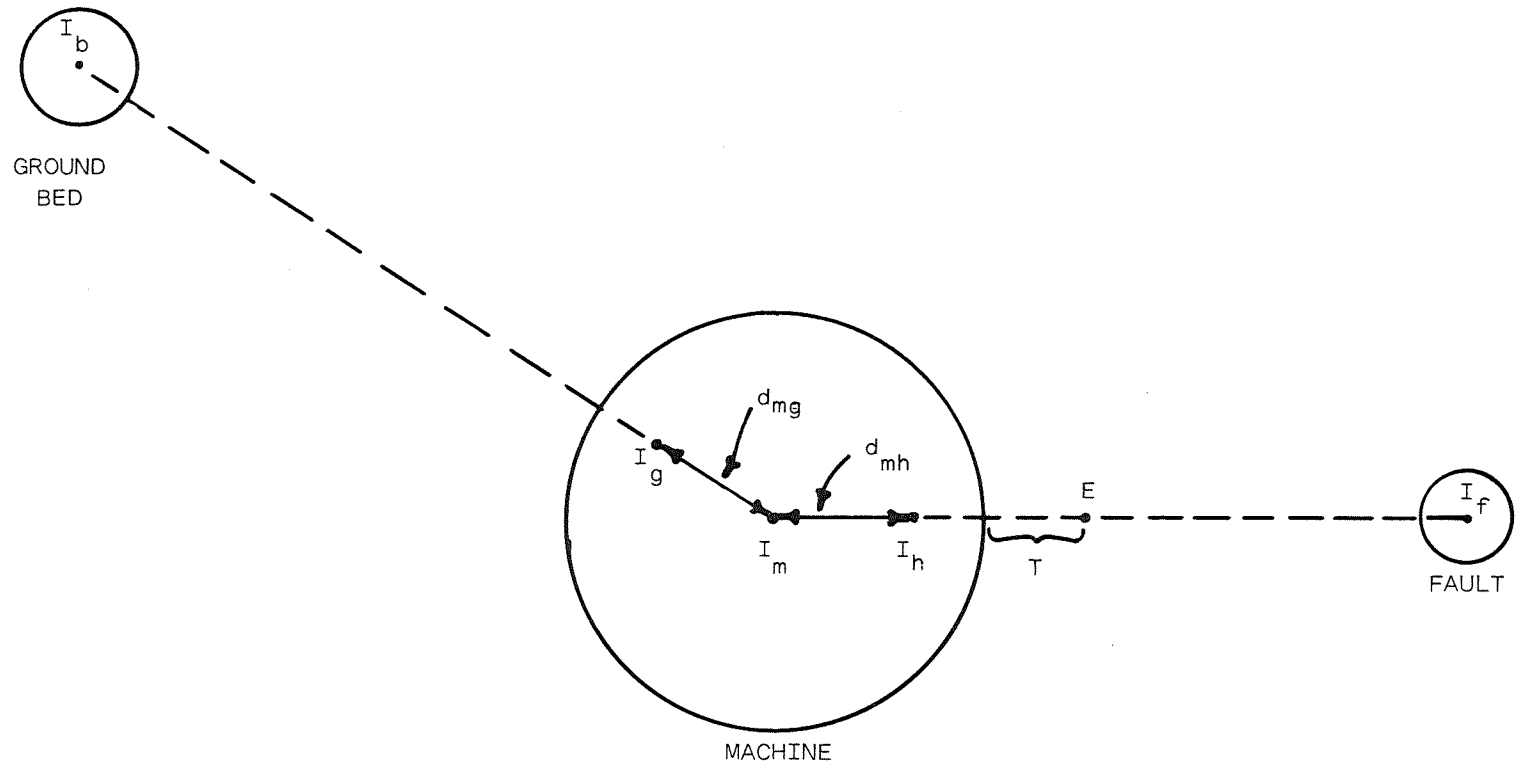

FIGURE 3.13 Location of Secondary Current Sources in the Machine Electrode

currents in the system and is given by:

$$I_m = I_f - I_b - I_g - I_h \quad (3.66)$$

In terms of the fault current and the ground bed current only,  $I_m$  becomes:

$$I_m = (1 - r_m/d_{mf})I_f - (1 - r_m/d_{mb})I_b \quad (3.67)$$

$I_m$  is located at the center of the machine electrode.

The potentials at the ground bed, the fault, the employee and the point on the machine that the employee would touch (T in Figure 3.12), are:

$$V_b = -I_f R_b - I_g R_{bg} - I_m R_{bm} - I_h R_{bh} + I_f R_{bf} \quad (3.68)$$

$$V_t = -I_b R_{tb} - I_g R_{tg} - I_m R_{tm} - I_h R_{th} + I_f R_{tf} \quad (3.69)$$

$$V_e = -I_b R_{eb} - I_g R_{eg} - I_m R_{em} - I_h R_{eh} + I_f R_{ef} \quad (3.70)$$

$$V_f = -I_b R_{fb} - I_g R_{fg} - I_m R_{fm} - I_h R_{fh} + I_f R_f \quad (3.71)$$

Substituting Equations 3.64 to 3.67 into Equations 3.68 to 3.71 gives the potentials in terms of the fault current and ground bed current only.

$$V_b = I_f (R_{bf} - (r_m/d_{mf})R_{bh} - (1 - r_m/d_{mf})R_{bm}) + I_b ((r_m/d_{mb})R_{bg} + (1 - r_m/d_{mb})R_{bm} - R_b) \quad (3.72)$$

$$V_t = I_f (R_{tf} - (r_m/d_{mf})R_{th} - (1 - r_m/d_{mf})R_{tm}) + I_b ((r_m/d_{mb})R_{tg} + (1 - r_m/d_{mb})R_{tm} - R_{tb}) \quad (3.73)$$

$$V_e = I_f (R_{ef} - (r_m/d_{mf})R_{eh} - (1 - r_m/d_{mf})R_{em}) + I_b ((r_m/d_{mb})R_{eg} + (1 - r_m/d_{mb})R_{em} - R_{eb}) \quad (3.74)$$

$$V_f = I_f (R_f - (r_m/d_{mf})R_{fh} - (1 - r_m/d_{mf})R_{fm}) + I_b ((r_m/d_{mb})R_{fg} + (1 - r_m/d_{mb})R_{fm} - R_{fb}) \quad (3.75)$$

Since the ground bed and the machine are tied together with a ground wire, their potentials are the same. Setting  $V_b = V_t$  and substituting Equations 3.4 and 3.6 for the resistance terms, the ground bed current  $I_b$  can be found in terms of the fault current  $I_f$  and is given in Equation 3.76.

$$I_b = I_f \frac{\frac{1}{r_m} + \frac{1}{d_{bf}} - \frac{1}{d_{mf}} - \frac{1}{d_{mb}} + \frac{r_m}{d_{mf}d_{mb}} - \frac{r_m}{d_{mf}d_{mb} + r_m^2}}{\frac{1}{r_b} + \frac{1}{r_m} - \frac{2}{d_{mb}} + \frac{r_m}{d_{mb}^2} - \frac{r_m}{d_{mb}^2 - r_m^2}} \quad (3.76)$$

In the case of a real-life ground fault the fault current will not be known directly, but the phase voltage of the grounded conductor will be known. For the phase-to-line voltage  $V_{ln}$  and the grounding resistor  $R$  in Figure 3.12 and knowing that  $V_f - V_b + I_f R = V_{ln}$ , the fault current in terms of the phase voltage of the grounded conductor is given in Equation 3.77.

$$\text{Let } A = \frac{1}{r_b} + \frac{1}{d_{mf}} - \frac{1}{d_{mb}} - \frac{1}{d_{bf}} + \frac{r_m}{d_{mb}^2} + \frac{r_m}{d_{mf}d_{mb} + r_m^2} - \frac{r_m}{d_{mf}d_{mb}} - \frac{r_m}{d_{mb}^2 - r_m^2}$$

$$\text{and } B = I_b/I_f \text{ from Equation 3.76}$$

$$\text{and } C = \frac{1}{r_f} + \frac{1}{d_{mb}} - \frac{1}{d_{mf}} - \frac{1}{d_{bf}} + \frac{r_m}{d_{mf}^2} + \frac{r_m}{d_{mb}d_{mf} + r_m^2} - \frac{r_m}{d_{mf}d_{mb}} - \frac{r_m}{d_{mb}^2 - r_m^2}$$

$$\text{Then } I_f = V_{ln}/(R + (\rho/2\pi)(AB + C)) \quad (3.77)$$

Substituting Equation 3.77 into Equation 3.76 gives the ground bed current in terms of the phase voltage of the fault. Substituting these two equations into Equations 3.73 and 3.74 gives the potential at the machine ( $V_t$ ) and the potential at the employee ( $V_e$ ) in terms of the phase voltage of the fault also. The touch potential  $T$  that a person will experience is the difference between  $V_e$  and  $V_t$  and is shown in Equation 3.78.

$$T = V_e - V_t \quad (3.78)$$

where  $V_e$  and  $V_t$  are expressed in terms of  $V_{ln}$ , the line-to-neutral voltage of the grounded conductor.

## CHAPTER 4 - COMPUTER ANALYSIS OF TOUCH POTENTIALS

The identification of the steepest potential gradients and highest touch potentials at large earth electrodes is critical to the development of the measurement procedures. A computer analysis of the touch-potential equations developed in Chapter 3 is applied here so that the locations of the highest touch potentials can be identified and investigated.

### 4.1 - SENSITIVITY ANALYSIS OF EACH PARAMETER

The sensitivity of the measured touch potentials to the variation of the electrical and physical parameters of the touch-potential equations was analyzed. The results are shown in Figures 4.1 through 4.6. Included with each graph is a diagram illustrating the layout of the electrodes. In all figures electrodes B, M, and F represent the ground bed, the machine, and the ground fault, respectively. Point E represents the location of a person's feet when in contact with the machine.  $R$  is the value of the ground resistor and  $\rho$  is the earth resistivity. The vertical axis in each graph shows the touch potential as a percentage of the voltage of the overhead line in contact with the earth.

Figure 4.1 shows the dependence of the touch potential on the radius of the ground fault electrode. The radius of the electrode corresponds directly to its contact area. For large contact areas, the curves level off as the contact resistance of the ground fault becomes small and the magnitude of the fault current is then determined by other larger impedances. For very small contact areas, the fault contact resistance predominates, and the touch potential is seen to increase directly with the contact area. The variation of touch potential with contact area has been shown for five different values of distance between the fault and the mining machine, illustrating the much larger effect of this distance on the touch potentials.

In Figure 4.2 the touch potential versus distance to the ground bed is plotted for six different values of distance between the fault and the machine. In all cases the plots are horizontal lines, indicating that the distance to the ground bed from the machine has very little effect on the touch potential.

Figure 4.3 shows the effect of the grounding resistance on the touch potentials. The mechanism here is that of limiting the fault current; for very large values of resistance, there is little dependence on the numerical value of the resistance, because the circuit operates in a current-source mode. For other values of resistance the touch potential is seen to decrease as the resistance increases. For very small values of resistance, the curves tend to flatten out as the other impedances in the system determine the fault current.

Figure 4.4 shows the effect of earth resistivity on touch potential. The curves here appear to be mirror images of the ones in Figure 4.3 because the touch potentials are directly proportional to earth resistances, which are in turn directly proportional to the earth resistivity. At very large values of earth resistivity, however, the high resistances limit fault current, causing a flattening in the slope.

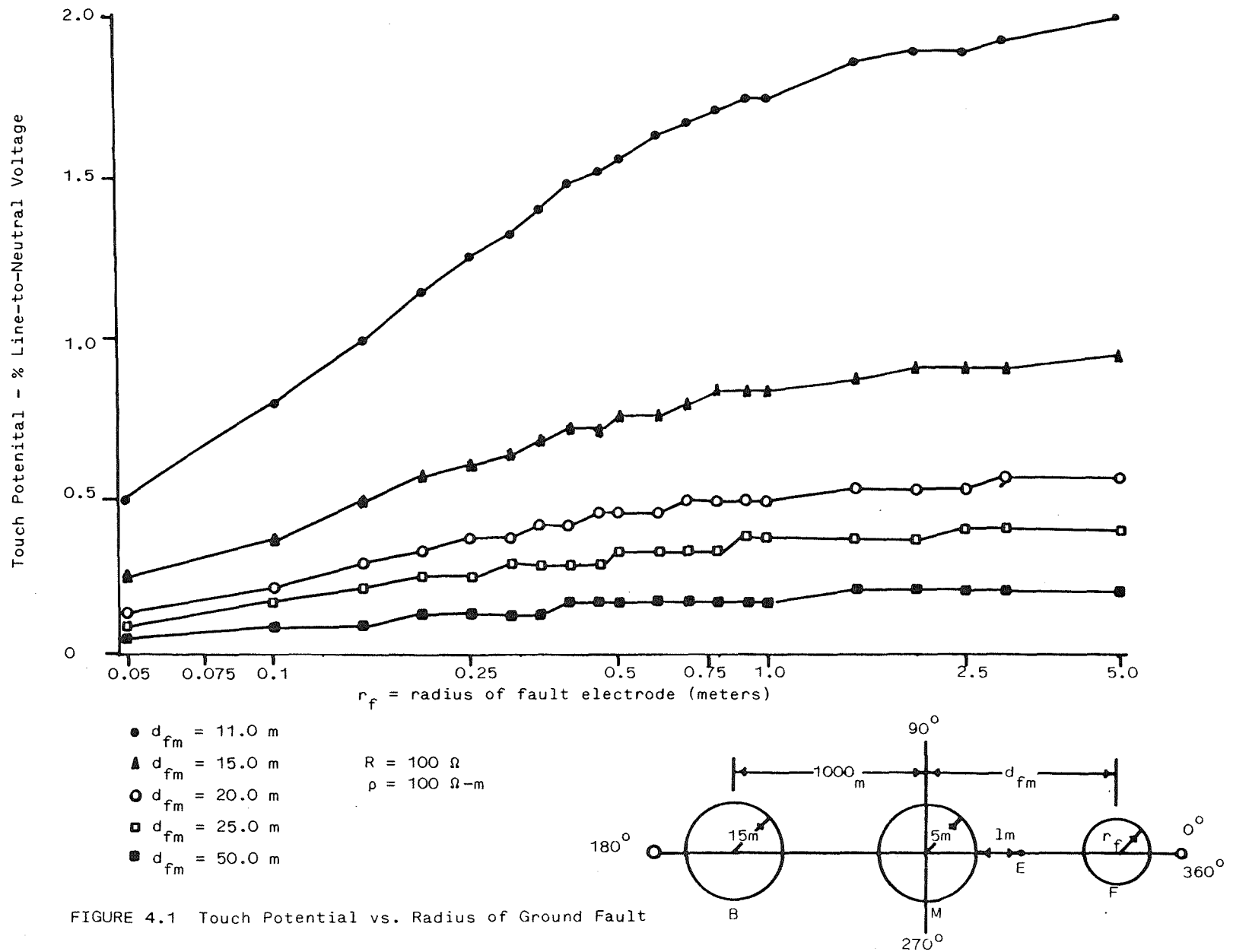
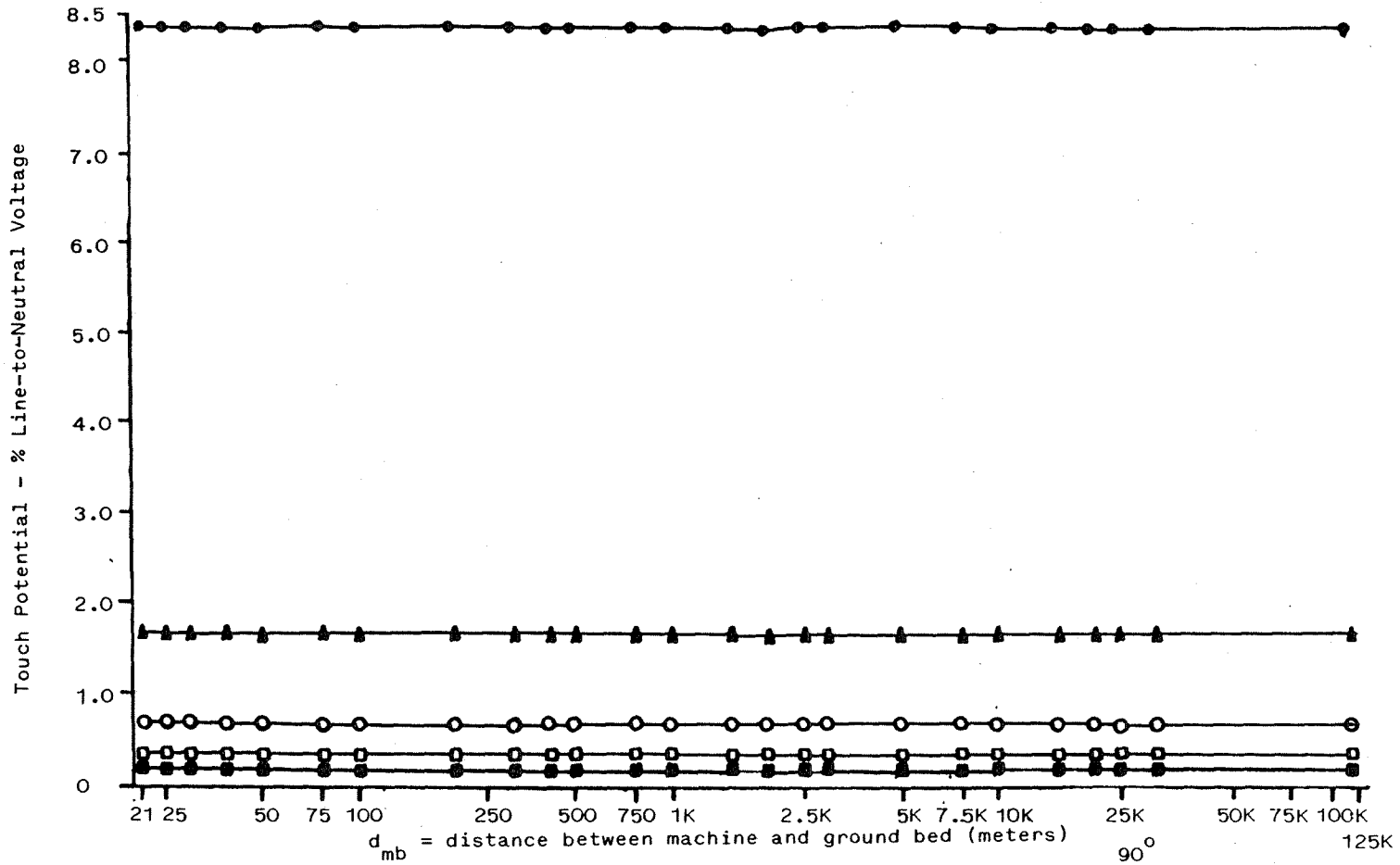

FIGURE 4.1 Touch Potential vs. Radius of Ground Fault



- $d_{fm} = 7.0$  m
- ▲  $d_{fm} = 10.0$  m
- $d_{fm} = 15.0$  m
- $d_{fm} = 20.0$  m
- $d_{fm} = 25.0$  m

$R = 100 \Omega$   
 $\rho = 100 \Omega\text{-m}$

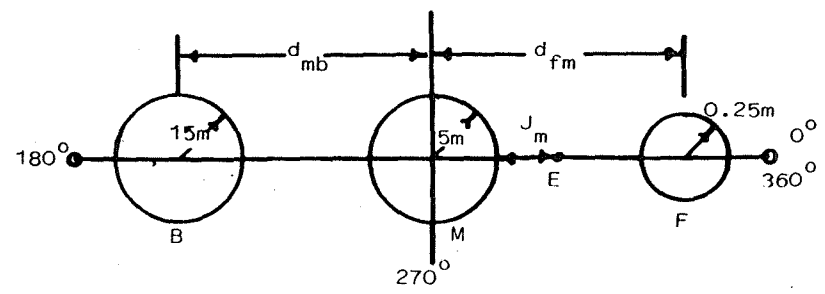
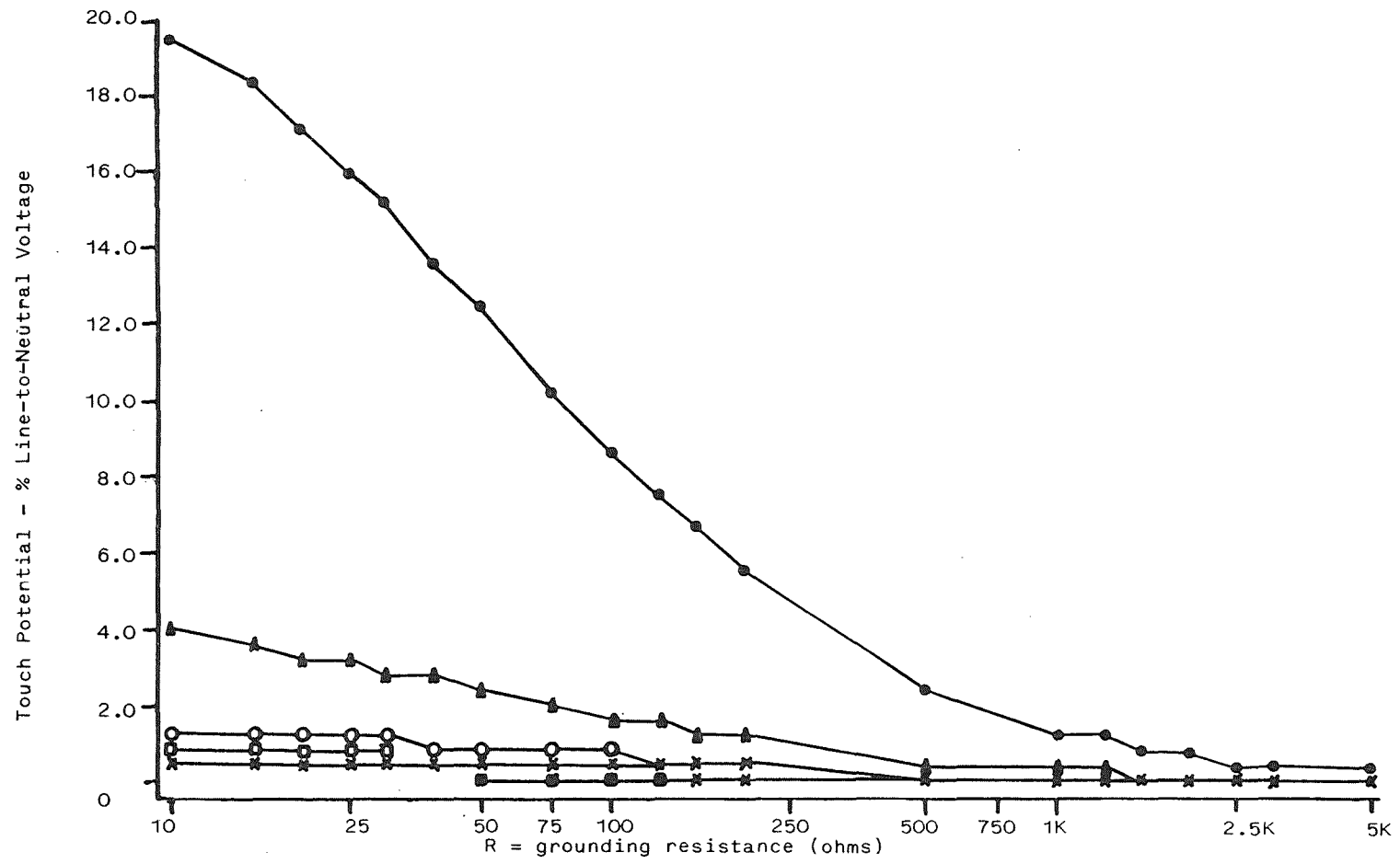

FIGURE 4.2 Touch Potential vs Distance Between Machine and Ground Bed



- $d_{fm} = 7.0 \text{ m}$
  - ▲  $d_{fm} = 10.0 \text{ m}$
  - $d_{fm} = 15.0 \text{ m}$
  - $d_{fm} = 20.0 \text{ m}$
  - $d_{fm} = 25.0 \text{ m}$
  - × signifies that two or more points overlap
- $\rho = 100 \Omega\text{-m}$

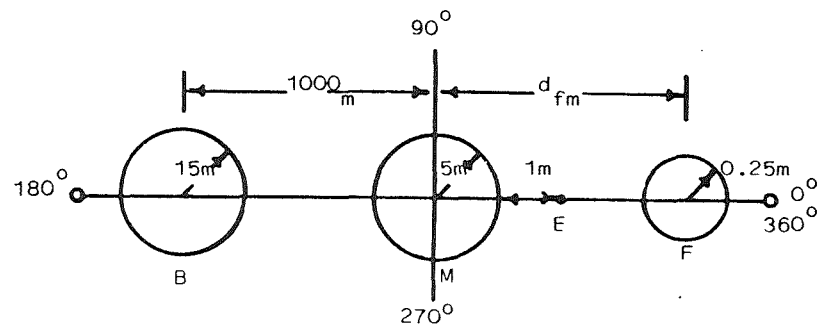

FIGURE 4.3 Touch Potential vs. Source Impedance

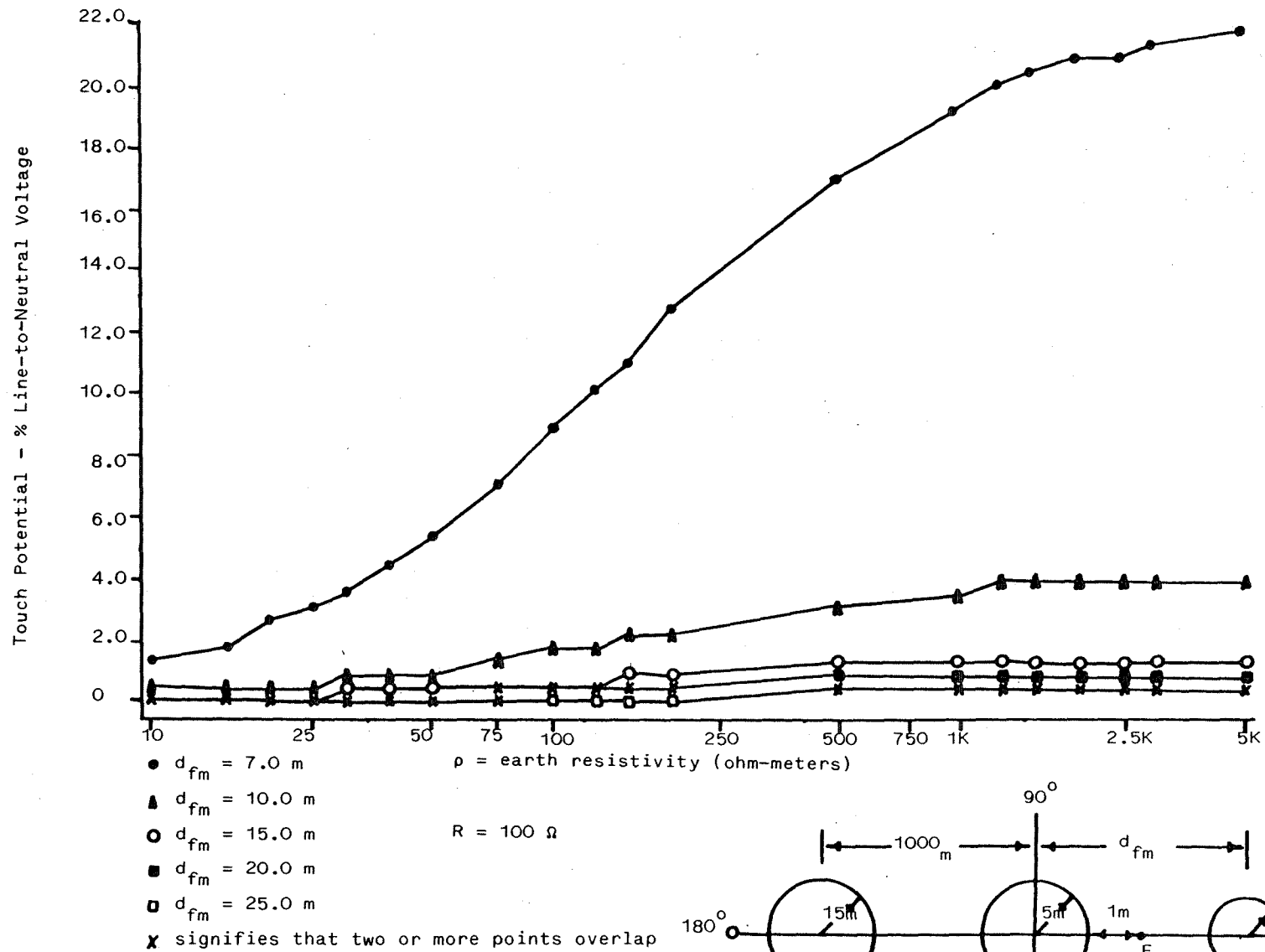

FIGURE 4.4 Touch Potential vs. Earth Resistivity

Likewise, at very small values of resistivity, there are very low potentials because the earth resistances are negligible.

Figures 4.5 and 4.6 show the effect of the size of the equivalent hemispheres of the mining machine and the ground bed, on the touch potentials. The radius of the ground bed has little effect. The radius of the machine appears to have an optimum value in Figure 4.5 to minimize the touch potential. While the larger radius tends to reduce the potential gradients, it also pushes the edge of the machine closer to the fault, which tends to increase the potential gradients, thus producing a minimum at the center of the graph. Therefore, for a fault that is of a sufficient distance from the machine, increasing the radius of the machine will decrease the touch potential. But for a fault that is close to a machine, increasing the radius of the machine will push the machine edge closer to the fault and will increase the touch potential.

## 4.2 TOUCH POTENTIALS

The touch potentials that appear at a machine or structure are affected by the distance to the ground fault, the shape of the machine or structure, and the position and distance of the ground bed in relation to the fault and the machine. The figures in Section 4.2 include diagrams illustrating the layouts of the electrodes for each graph. In all figures electrodes B, M, and F represent the ground bed, the machine, and the fault, respectively. Point E represents a person's earth contact, R is the value of the ground resistor, and  $\rho$  is the earth resistivity. Symbols  $\angle e$  and  $\angle b$  are the angles of the person and ground bed respectively around the machine with respect to the location of the ground fault. Point E is also the point where the touch potential is measured.

### 4.2.1 Distant Faults

Figures 4.7 through 4.12 show the variations of the touch potential around various machines for faults that are distant from the machine, i.e., located several machine radii away.

Figure 4.7 shows the touch potentials around a single-hemisphere machine with a single current source. The x-axis is expressed in degrees and represents a counter-clockwise rotation around the machine electrode from a given reference point. In this figure the reference is zero degrees and is the direction towards the ground fault. The four curves represent four different locations of the ground bed around the machine. In this case, the fault is more distant from the machine than the ground bed. As can be seen in all four curves, the touch potential is highest on the point of the machine that is opposite the ground bed. The highest overall touch potential occurs when the ground bed is on the opposite side of the machine from the fault ( $\angle b = 180^\circ$ ), and it is located at the point on the machine that is closest to the fault ( $\angle e = 0^\circ$ ).

Figure 4.8 shows the same situation as Figure 4.7 except that the ground bed is now further from the machine than the fault. It can be seen here that the position of the ground bed has less effect on the touch potentials than it did in Figure 4.7. In all four cases the highest touch

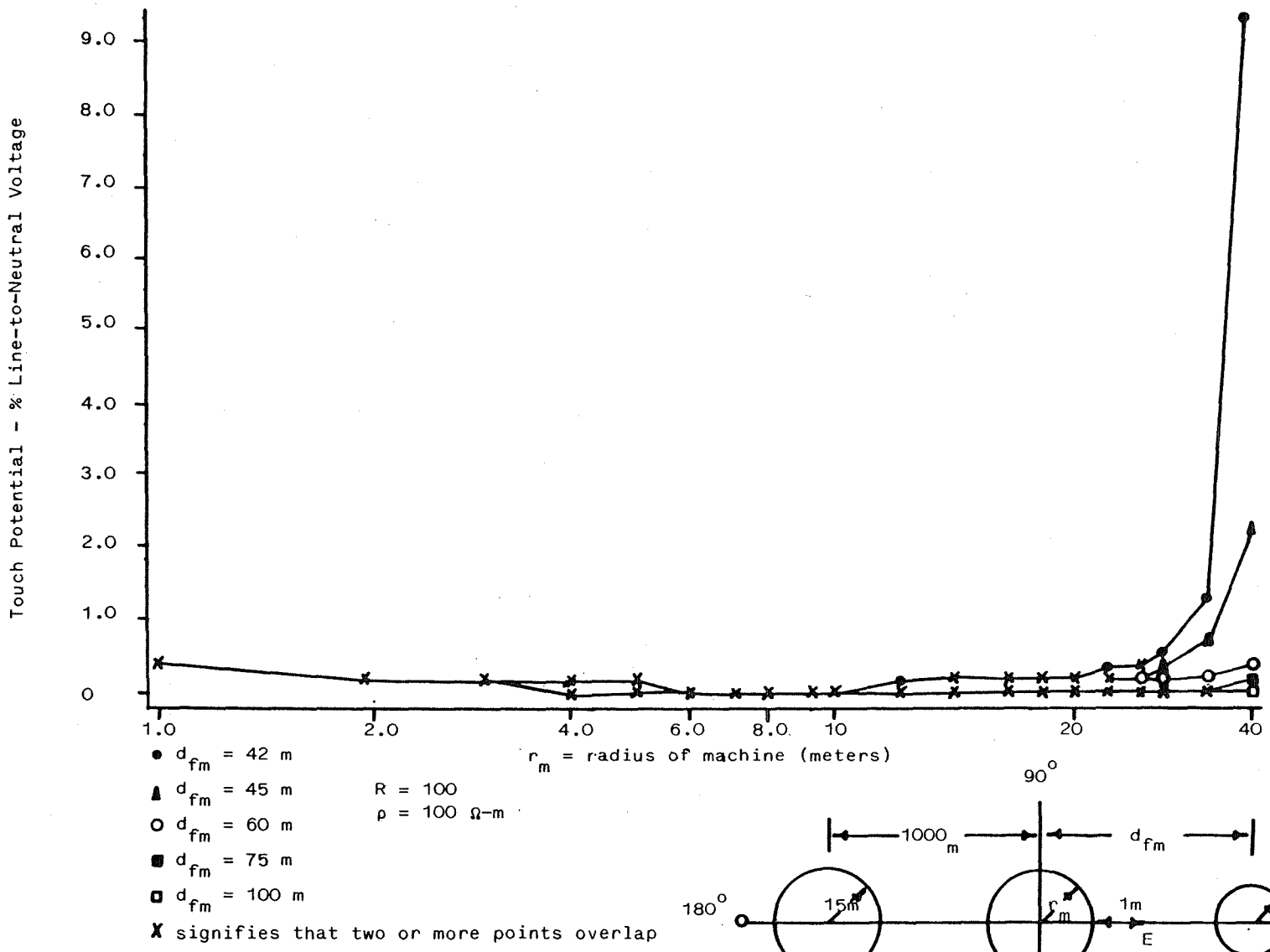
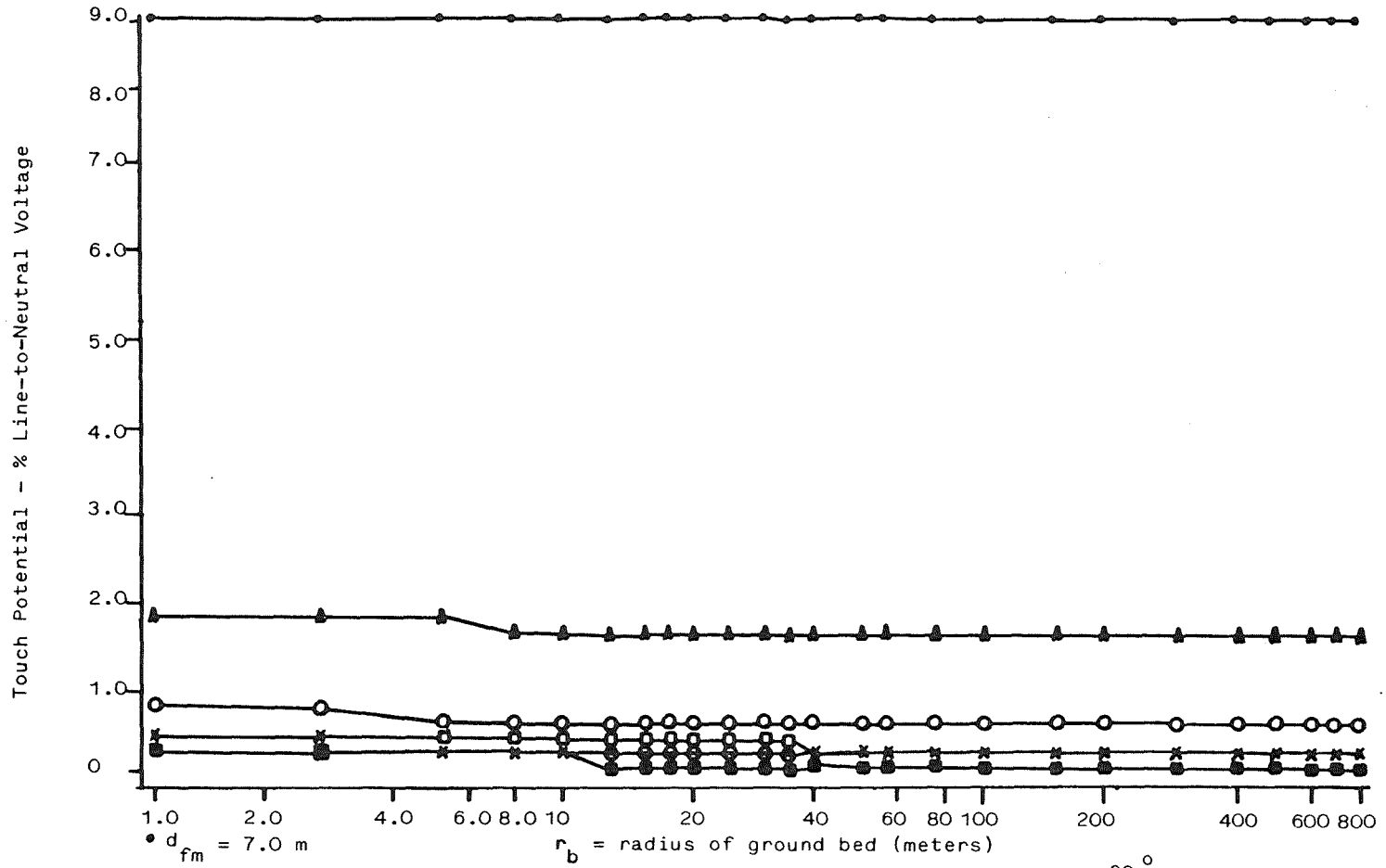

FIGURE 4.5 Touch Potential vs. Radius of Machine



$r_b$  = radius of ground bed (meters)  
 •  $d_{fm} = 7.0$  m  
 ▲  $d_{fm} = 10.0$  m  
 ○  $d_{fm} = 15.0$  m  
 □  $d_{fm} = 20.0$  m  
 ■  $d_{fm} = 25.0$  m  
 ●  $d_{fm} = 50.0$  m  
 x signifies that two or more points overlap

$R = 100 \Omega$   
 $\rho = 100 \Omega\text{-m}$

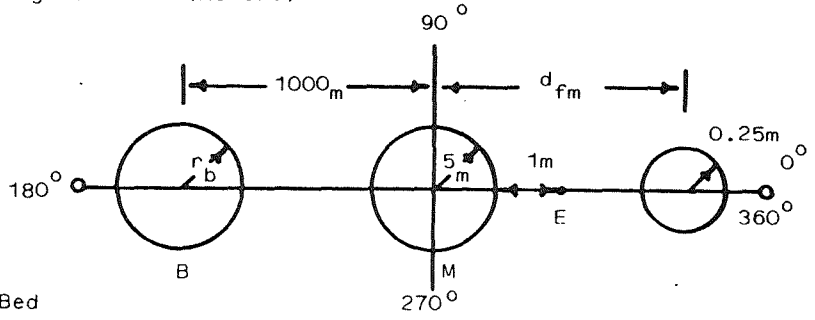

FIGURE 4.6 Touch Potential vs. Radius of Ground Bed

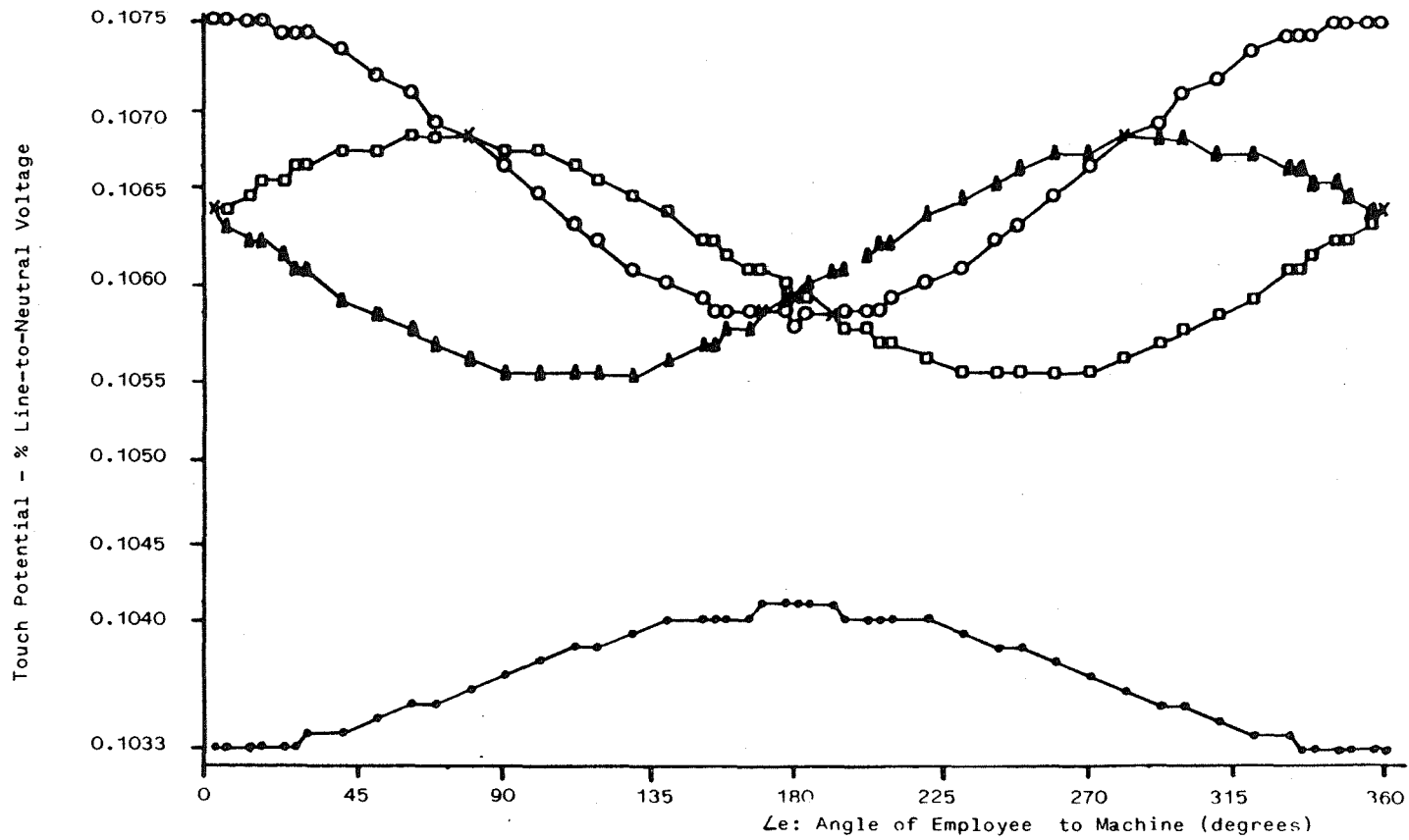
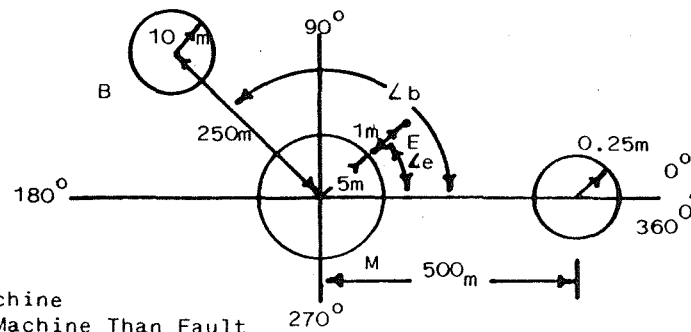
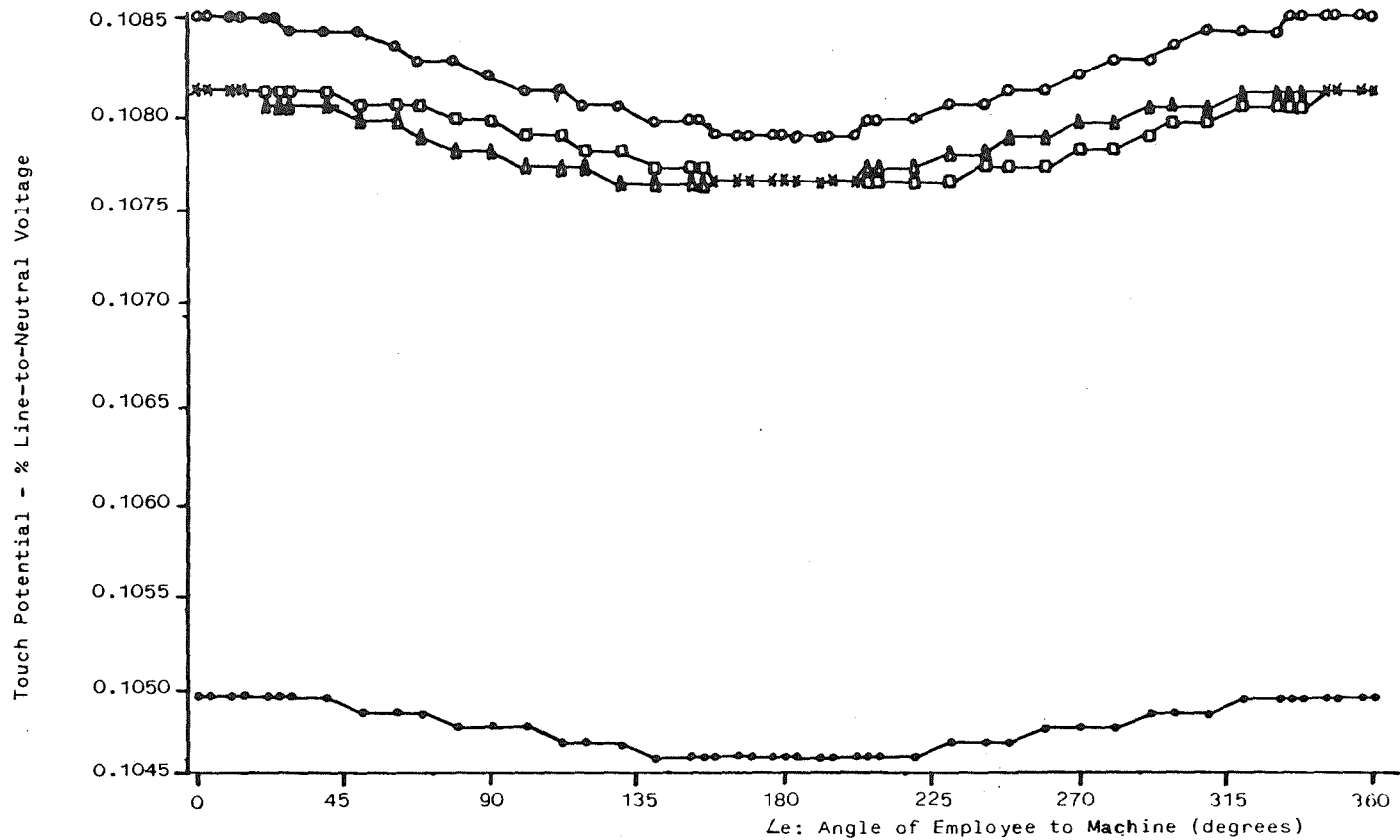

FIGURE 4.7 Touch Potentials Around a Single Hemisphere Machine (Single Current Source), Ground Bed Closer to Machine Than Fault





- $\angle b = \text{Angle Ground Bed to Machine} = 0^\circ$
- ▲  $\angle b = \text{Angle Ground Bed to Machine} = 90^\circ$
- $\angle b = \text{Angle Ground Bed to Machine} = 180^\circ$
- $\angle b = \text{Angle Ground Bed to Machine} = 270^\circ$
- × signifies that two or more points overlap

$R = 100 \Omega$   
 $\rho = 100 \Omega\text{-m}$

FIGURE 4.8 Touch Potentials Around a Single Hemisphere Machine (Single Current Source), Fault Closer to Machine Than Ground Bed

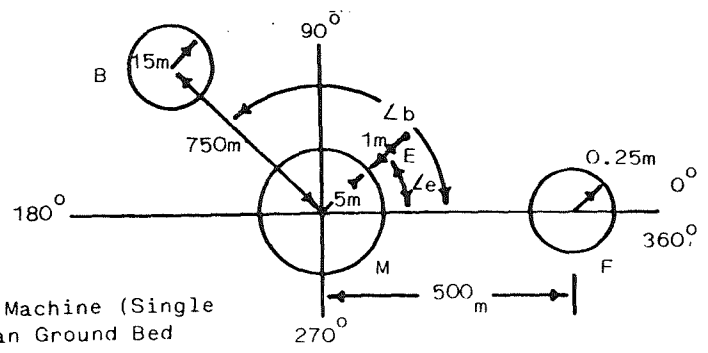

potentials occur on that point of the machine nearest to the fault ( $\angle e = 0^\circ$ ). As in Figure 4.7, the absolute highest touch potential occurs when the ground bed is located on the opposite side of the machine from the fault ( $\angle b = 180^\circ$ ).

Figure 4.9 shows the touch potentials around a single-hemisphere machine with dual current sources, two sources for each current source external to the machine. (Dual current sources are explained in Section 3.4.4.) The ground bed is closer to the machine than the fault. The position of the ground bed has a less pronounced effect on the touch potentials than it did in the single current source case in Figure 4.7. However, the maximum touch potential still occurs on the side of the machine opposite the ground bed, and is at its absolute maximum when the ground bed is located on the opposite side of the machine from the fault ( $\angle b = 180^\circ$  and  $\angle e = 90^\circ$ ).

Figure 4.10 shows the same setup as in Figure 4.9 except that the ground bed is further away from the machine than the fault. This graph is nearly identical to Figure 4.8 except that the difference between the highest and lowest touch potentials for a given location of the ground bed is less pronounced in Figure 4.10.

Figures 4.11 and 4.12 show the touch potentials around a machine modeled with two hemispheres to represent an elongated contact area. Both figures represent distant faults with the ground bed further from the machine than the fault. In Figure 4.11, the fault is nearer a narrow end of the machine (colinear with the hemispheres; see accompanying diagram). The fault is nearer a long side of the machine (perpendicular to the hemispheres; see accompanying diagram) in Figure 4.12. The two graphs are nearly identical. The maximum touch potential occurs at the center of both long sides of the machine ( $\angle e = 0^\circ$  and  $270^\circ$ ) for all ground bed locations.

#### 4.2.2 Nearby Faults

Figures 4.13 through 4.16 show the variations of the touch potentials around various machine models for faults near the machine, i.e., located less than one machine radius away from the surface of the machine.

Figure 4.13 shows the touch potentials around a single-hemisphere machine with a single current source at its center. The fault occurs near the machine with the ground bed located further from the machine than the fault. The difference in magnitude between the highest and lowest touch potential for each location of the ground bed is much greater than in the case for the distant fault in Figure 4.7. Here, the location of the maximum touch potential is very dependent on the location of the fault and not on the location of the ground bed. In all cases, the maximum touch potential occurs at the point on the machine closest to the fault ( $\angle e = 0^\circ$ ). The absolute maximum touch potential occurs when the ground bed is on the side of the machine opposite the fault ( $\angle b = 180^\circ$ ).

Figure 4.14 shows the touch potentials around a machine modeled with two current sources within it. All other conditions are identical to those in Figure 4.13. The magnitudes of the touch potentials are less than

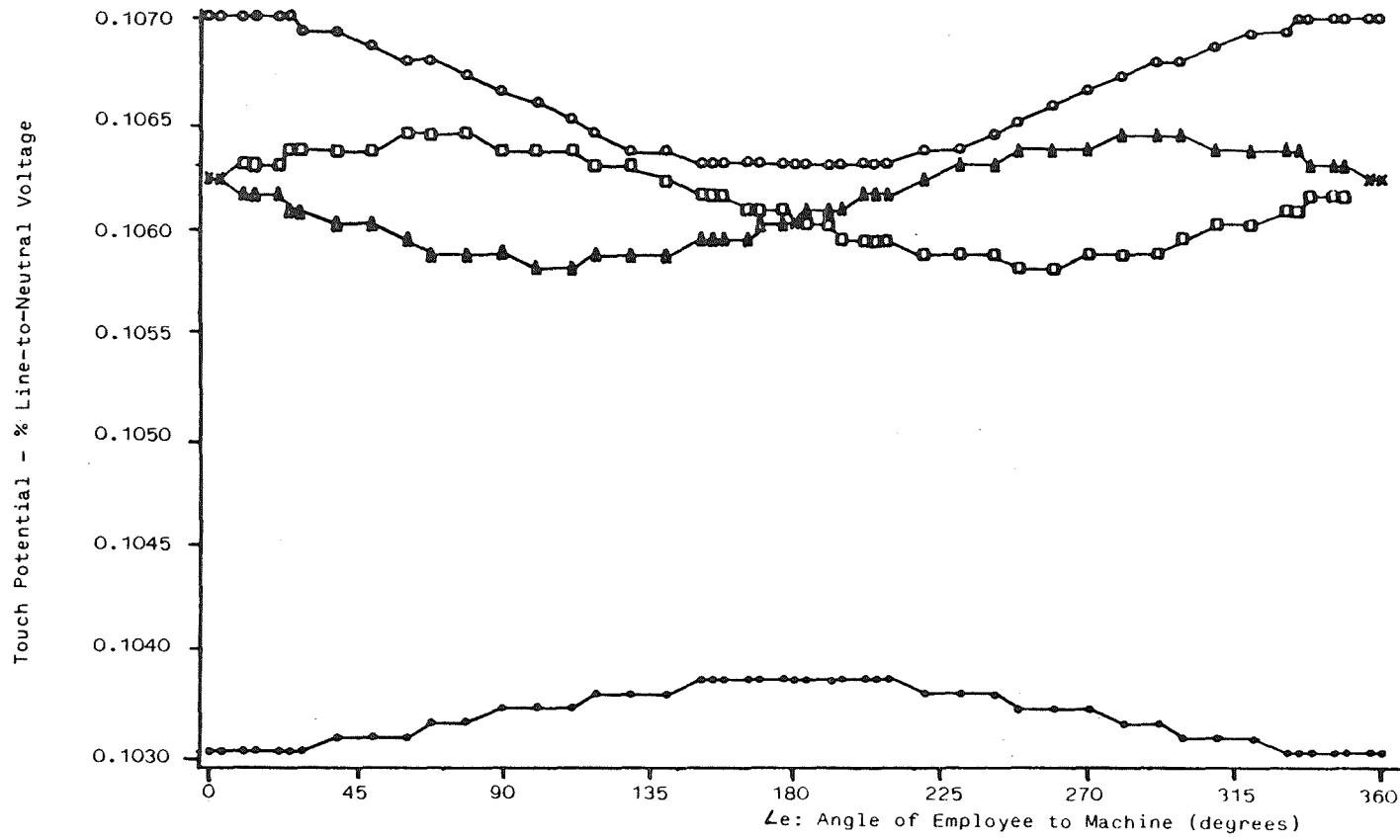

- $\angle b = \text{Angle Ground Bed to Machine} = 0^\circ$
- ▲  $\angle b = \text{Angle Ground Bed to Machine} = 90^\circ$
- $\angle b = \text{Angle Ground Bed to Machine} = 180^\circ$
- ◻  $\angle b = \text{Angle Ground Bed to Machine} = 270^\circ$
- × signifies that two or more points overlap
- $R = 100 \Omega$
- $\rho = 100 \Omega\text{-m}$

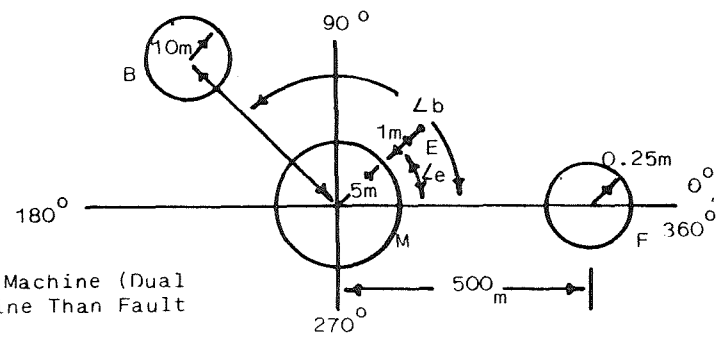
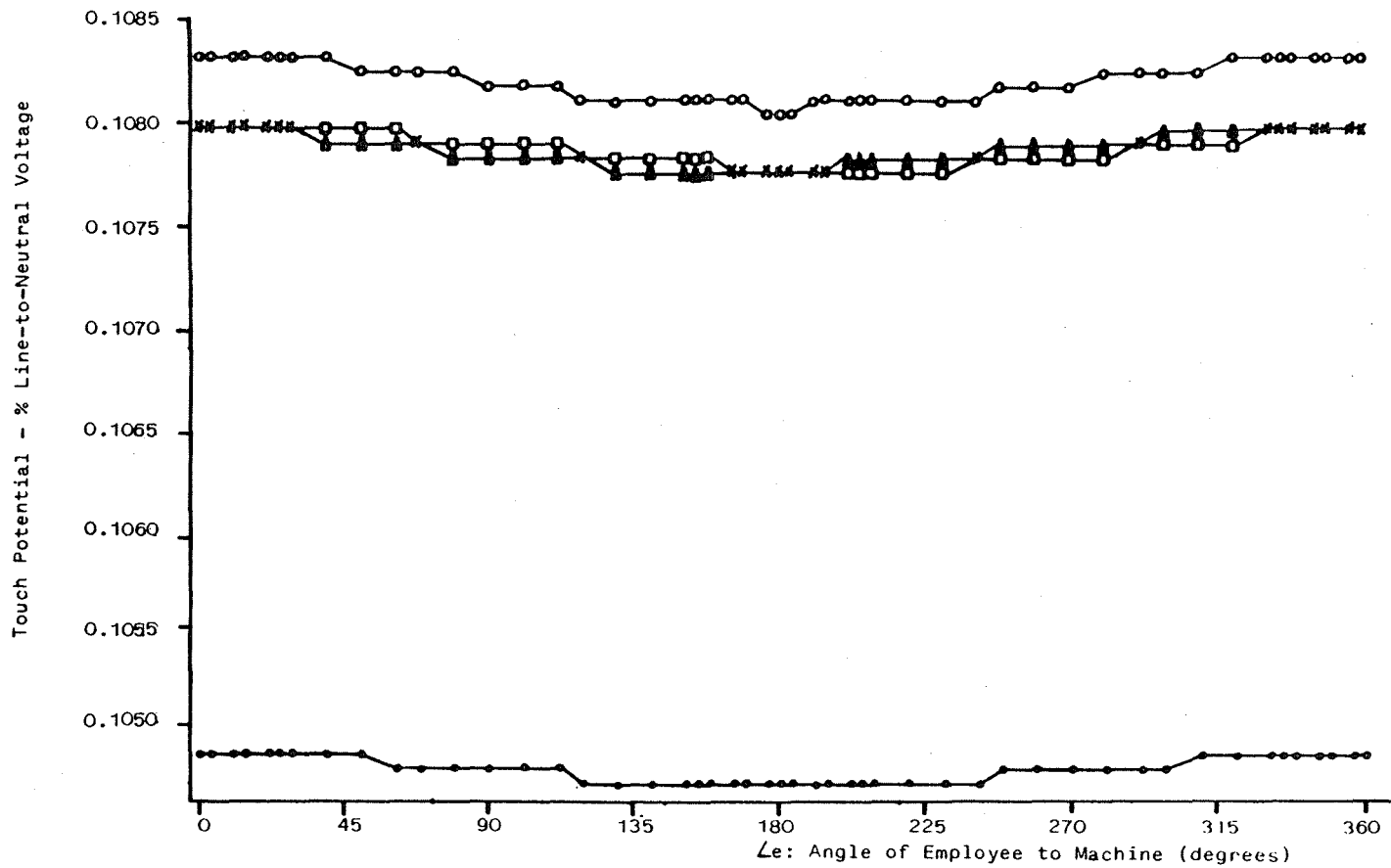

FIGURE 4.9 Touch Potentials Around a Single Hemisphere Machine (Dual Current Sources), Ground Bed Closer to Machine Than Fault



- $\angle b$  = Angle Ground Bed to Machine =  $0^\circ$
- ▲  $\angle b$  = Angle Ground Bed to Machine =  $90^\circ$
- $\angle b$  = Angle Ground Bed to Machine =  $180^\circ$
- ◻  $\angle b$  = Angle Ground Bed to Machine =  $270^\circ$
- × signifies that two or more points overlap
- $R = 100 \Omega$
- $\rho = 100 \Omega\text{-m}$

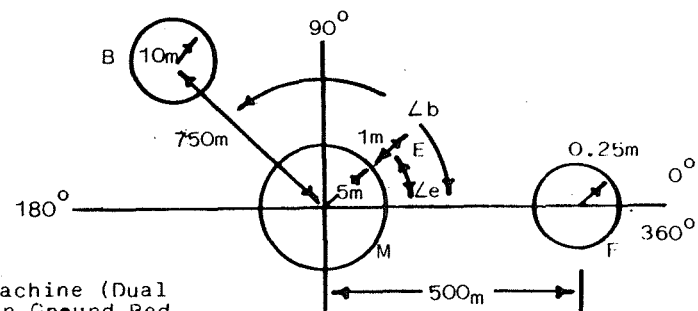
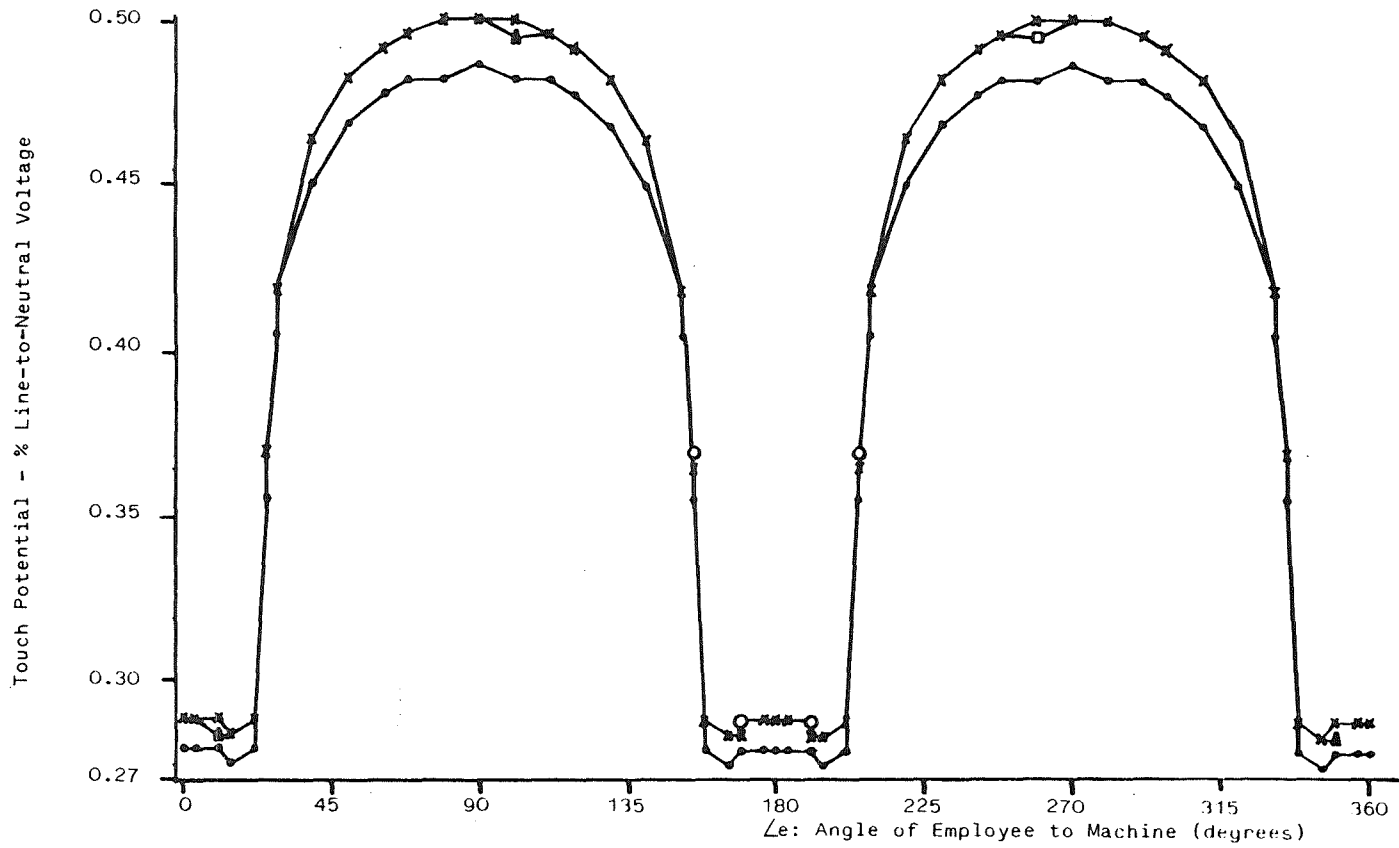

FIGURE 4.10 Touch Potentials Around a Single Hemisphere Machine (Dual Current Sources), Fault Closer to Machine than Ground Bed



- $\angle b$  = Angle Ground Bed to Machine =  $0^\circ$
  - ▲  $\angle b$  = Angle Ground Bed to Machine =  $90^\circ$
  - $\angle b$  = Angle Ground Bed to Machine =  $180^\circ$
  - ◻  $\angle b$  = Angle Ground Bed to Machine =  $270^\circ$
  - ✕ signifies that two or more points overlap
- $R = 100 \Omega$   
 $\rho = 100 \Omega\text{-m}$

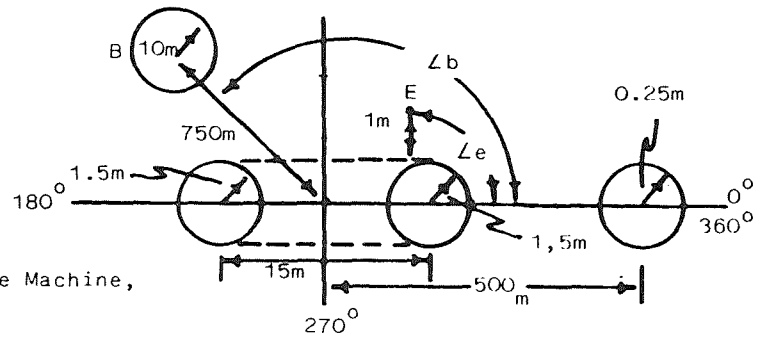
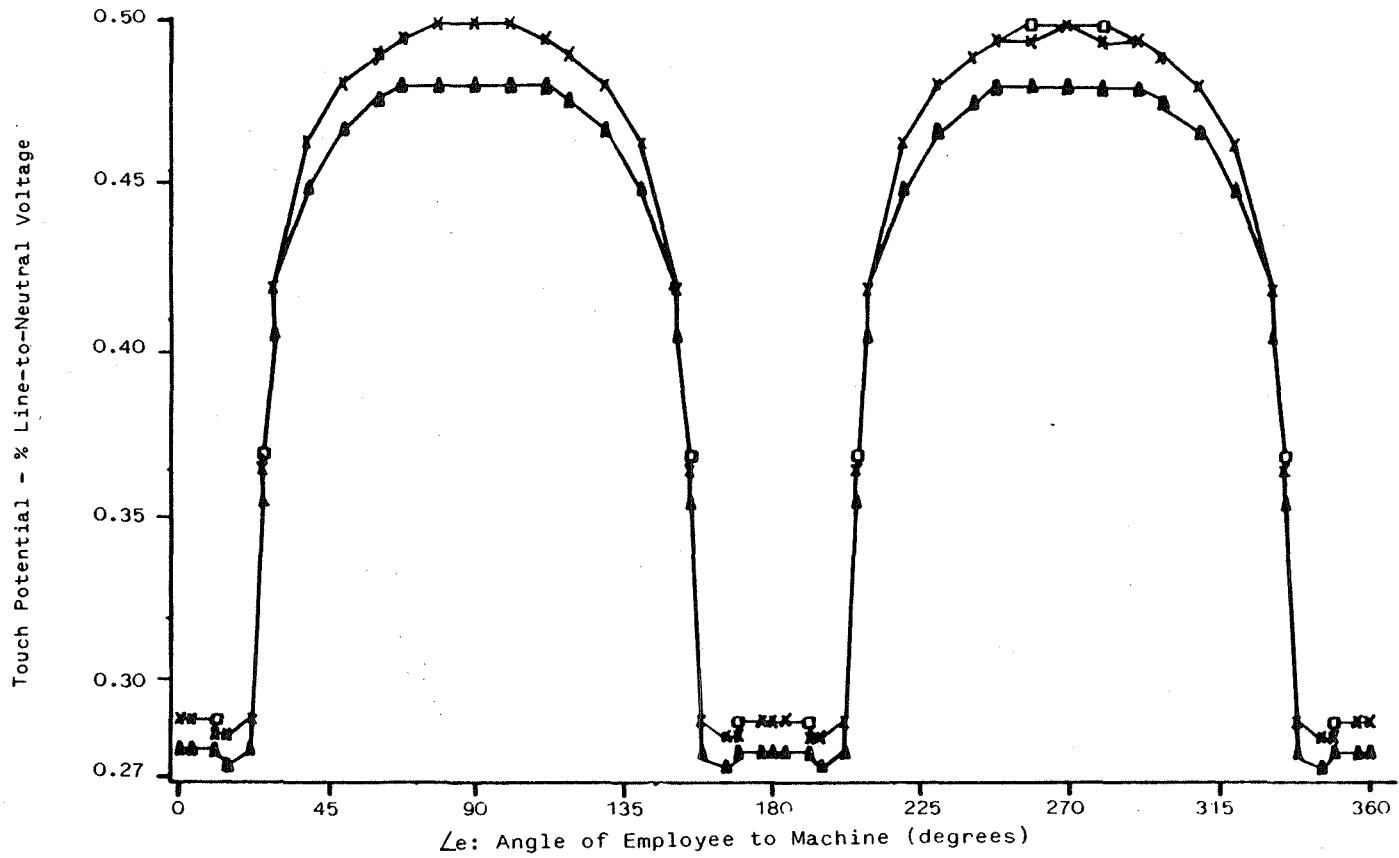

FIGURE 4.11 Touch Potentials Around a Double-Hemisphere Machine, Fault Near Narrow End



- $\angle b$  = Angle Ground Bed to Machine =  $0^\circ$
- ▲  $\angle b$  = Angle Ground Bed to Machine =  $90^\circ$
- ◐  $\angle b$  = Angle Ground Bed to Machine =  $180^\circ$
- ◑  $\angle b$  = Angle Ground Bed to Machine =  $270^\circ$
- X signifies that two or more points overlap
- R =  $100 \Omega$
- $\rho$  =  $100 \Omega\text{-m}$

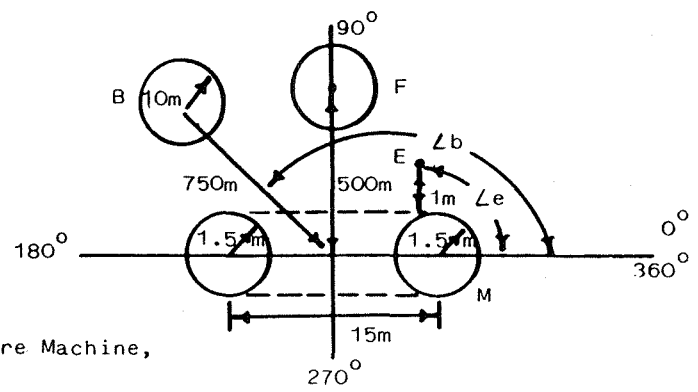
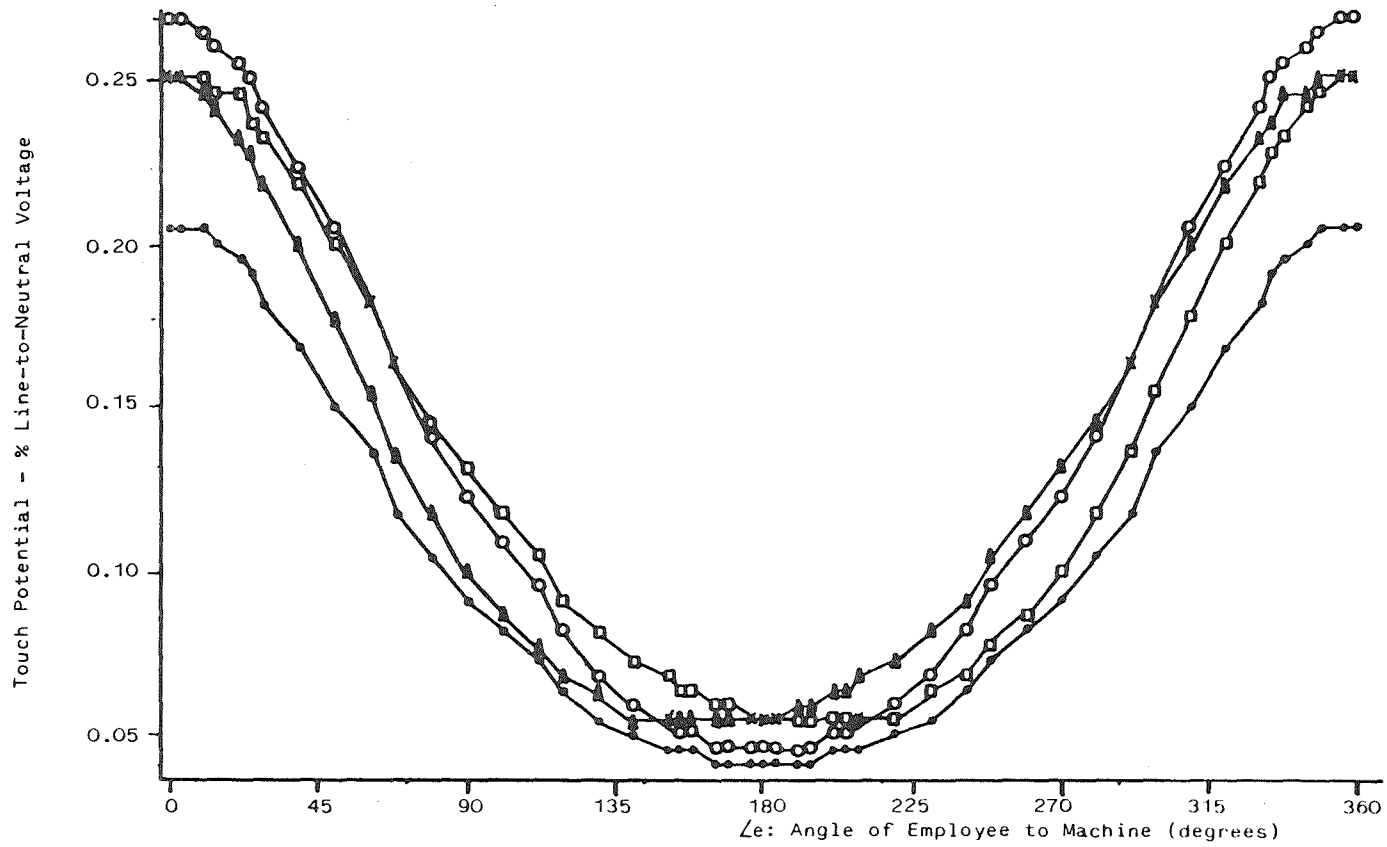

FIGURE 4.12 Touch Potentials Around a Double Hemisphere Machine, Fault Near Long Side



- $Z_b = \text{Angle Ground Bed to Machine} = 0^\circ$
- ▲  $Z_b = \text{Angle Ground Bed to Machine} = 90^\circ$
- $Z_b = \text{Angle Ground Bed to Machine} = 180^\circ$
- $Z_b = \text{Angle Ground Bed to Machine} = 270^\circ$
- × signifies that two or more points overlap
- $R = 100 \Omega$
- $\rho = 100 \Omega\text{-m}$

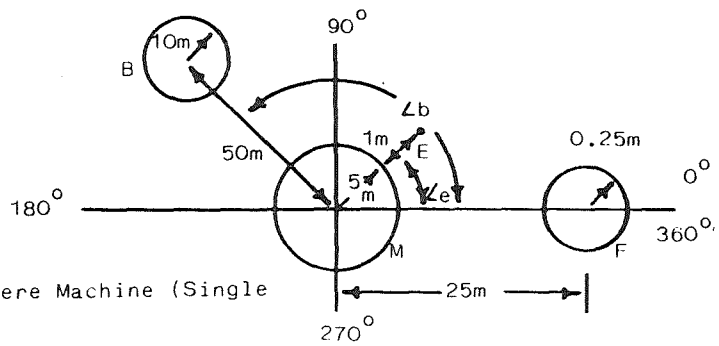
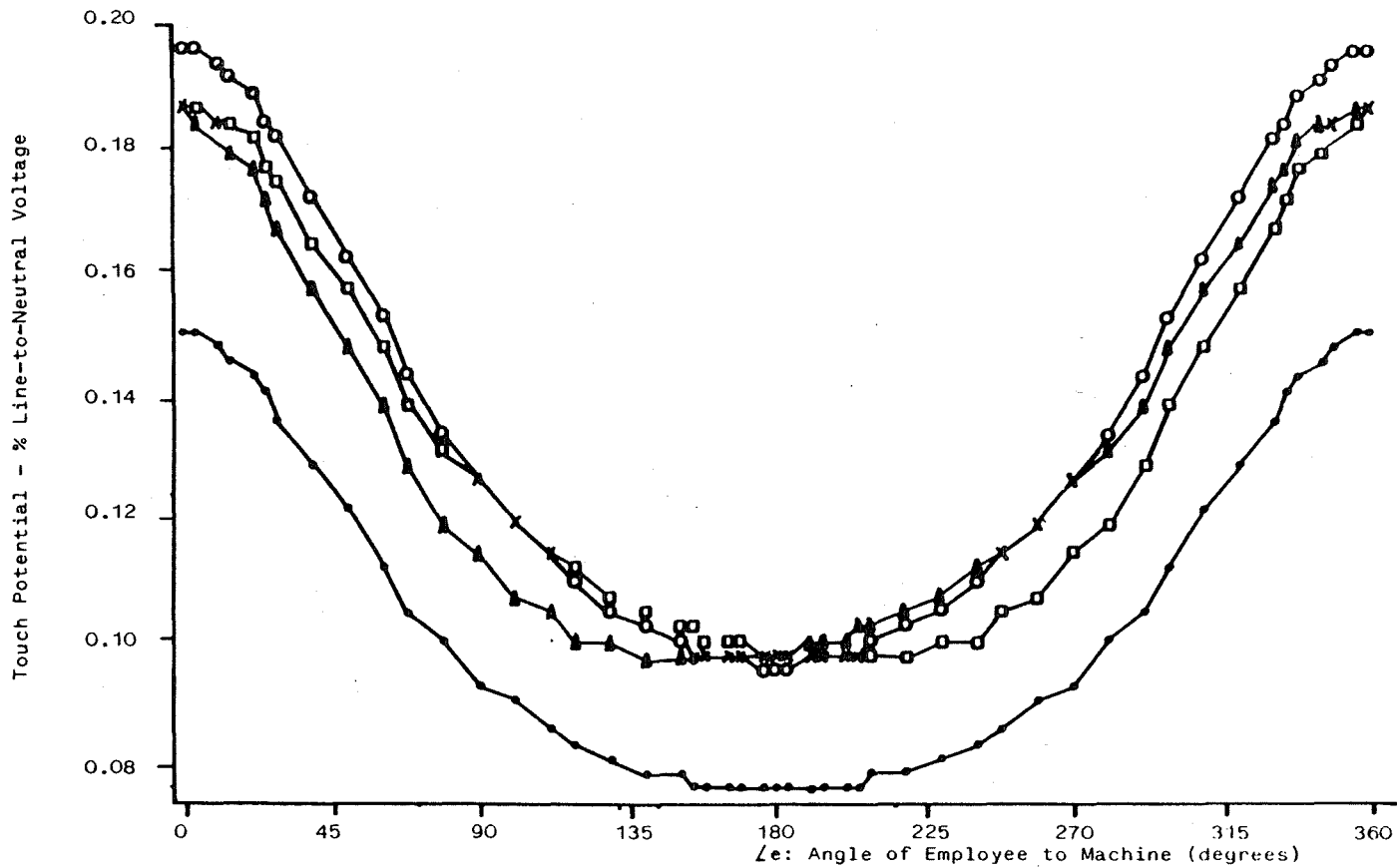
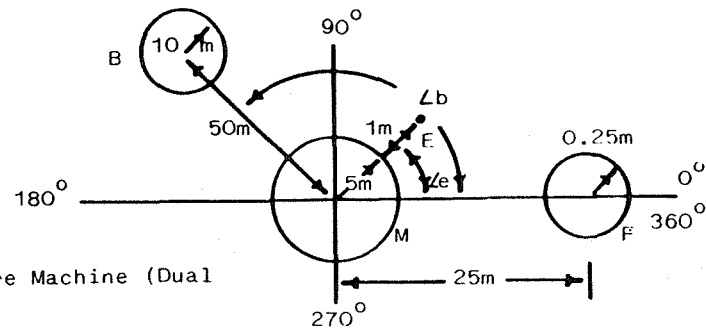

FIGURE 4.13 Touch Potentials Around a Single Hemisphere Machine (Single Current Source) For a Nearby Fault



- $\angle b$  = Angle Ground Bed to Machine =  $0^\circ$
  - ▲  $\angle b$  = Angle Ground Bed to Machine =  $90^\circ$
  - $\angle b$  = Angle Ground Bed to Machine =  $180^\circ$
  - ◻  $\angle b$  = Angle Ground Bed to Machine =  $270^\circ$
  - × signifies that two or more points overlap
- $R = 100 \Omega$   
 $\rho = 100 \Omega\text{-m}$

FIGURE 4.14 Touch Potentials Around a Single Hemisphere Machine (Dual Current Sources) For a Nearby Fault



in the single current source case and the variations in the magnitude of the touch potential for each position of the ground bed is less. As with the single current source, the location of the maximum touch potential is mainly dependent on the location of the fault, and the absolute maximum touch potential occurs when the ground bed is opposite the fault ( $\angle e = 0^\circ$  and  $\angle b = 180^\circ$ ).

Figures 4.15 and 4.16 show the touch potentials around double-hemisphere machines for faults occurring nearby. Figure 4.15 shows the case where the fault occurs near a narrow end of the machine (fault is colinear with the two hemispheres; see accompanying diagram). There is a local maximum at the point near the fault ( $\angle e = 0^\circ$ ), but the absolute maximum touch potential occurs along each side of the machine when the ground bed is located on the opposite side of the machine from the ground fault ( $\angle b = 180^\circ$  and  $\angle e = 60^\circ$  and  $300^\circ$ ). Figure 4.16 shows the case where the fault occurs near one long side of the machine (fault at  $90^\circ$ ). Once again, the touch potentials are influenced by the location of the ground bed. The maximum touch potential occurs at the center of the side of the machine nearest the fault ( $\angle b = 270^\circ$  and  $\angle e = 90^\circ$ ).

### 4.3 EQUIPOTENTIAL MAPS

To better understand the behavior of the electric fields in the vicinity of the machine during ground faults, equipotential maps were generated by computer. These maps are shown in Figures 4.17 through 4.19. Figure 4.17 is a plot of the potential field surrounding a single-hemisphere machine during a ground fault. The machine is located at the center of the map with the fault to its right and the ground bed to its left. The closely spaced equipotential lines on the side of the machine nearest the fault indicate steep potential gradients in this area and correspondingly high touch potentials.

Figures 4.18 and 4.19 are equipotential plots for earth faults occurring near double-hemisphere machines. Figure 4.18 shows a fault near a narrow end of the machine. The fault is to the right of the machine and the ground bed is to the left. Figure 4.19 depicts the case where the fault is near a long side of the machine. In this figure, the fault is towards the top of the map and the ground bed is just below the bottom edge of the map. In both figures, the steepest gradients are located around the ends of the machine where the hemispheres are in contact with the earth. This is where one would expect the highest touch potentials to occur. But as indicated in Figures 4.11, 4.12, 4.15, and 4.16, the highest touch potentials occur at the sides of the machine. This occurs because the middle of the machine model is not in contact with the earth, only the ends where the hemispheres are located are in contact with the earth. Therefore, a person standing along the long side of the machine is not in an area of steep potential gradients, but is in an area where the earth potential is much higher than the machine potential in the same area. If the entire machine model were in contact with the earth, the potential of the earth along the sides of the machine would drop and would correspondingly reduce the touch potentials in this area.

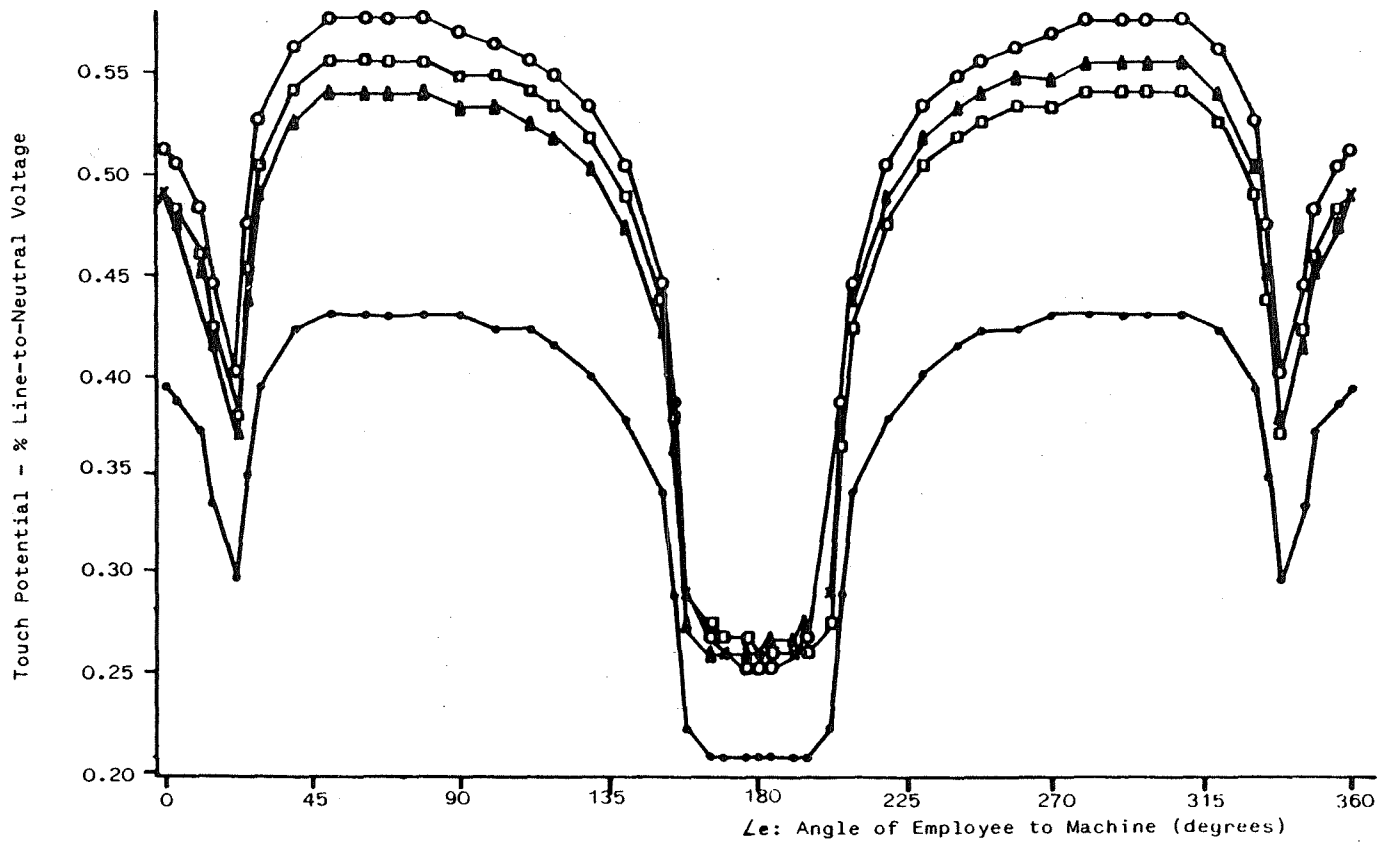

- $\angle b$  = Angle Ground Bed to Machine =  $0^\circ$
- ▲  $\angle b$  = Angle Ground Bed to Machine =  $90^\circ$
- $\angle b$  = Angle Ground Bed to Machine =  $180^\circ$
- ◻  $\angle b$  = Angle Ground Bed to Machine =  $270^\circ$
- x signifies that two or more points overlap

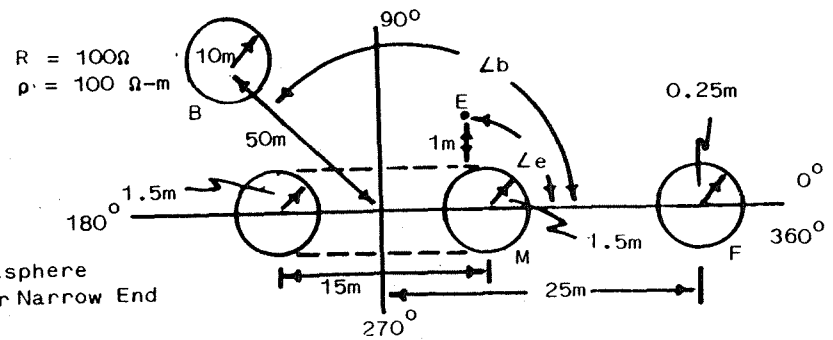
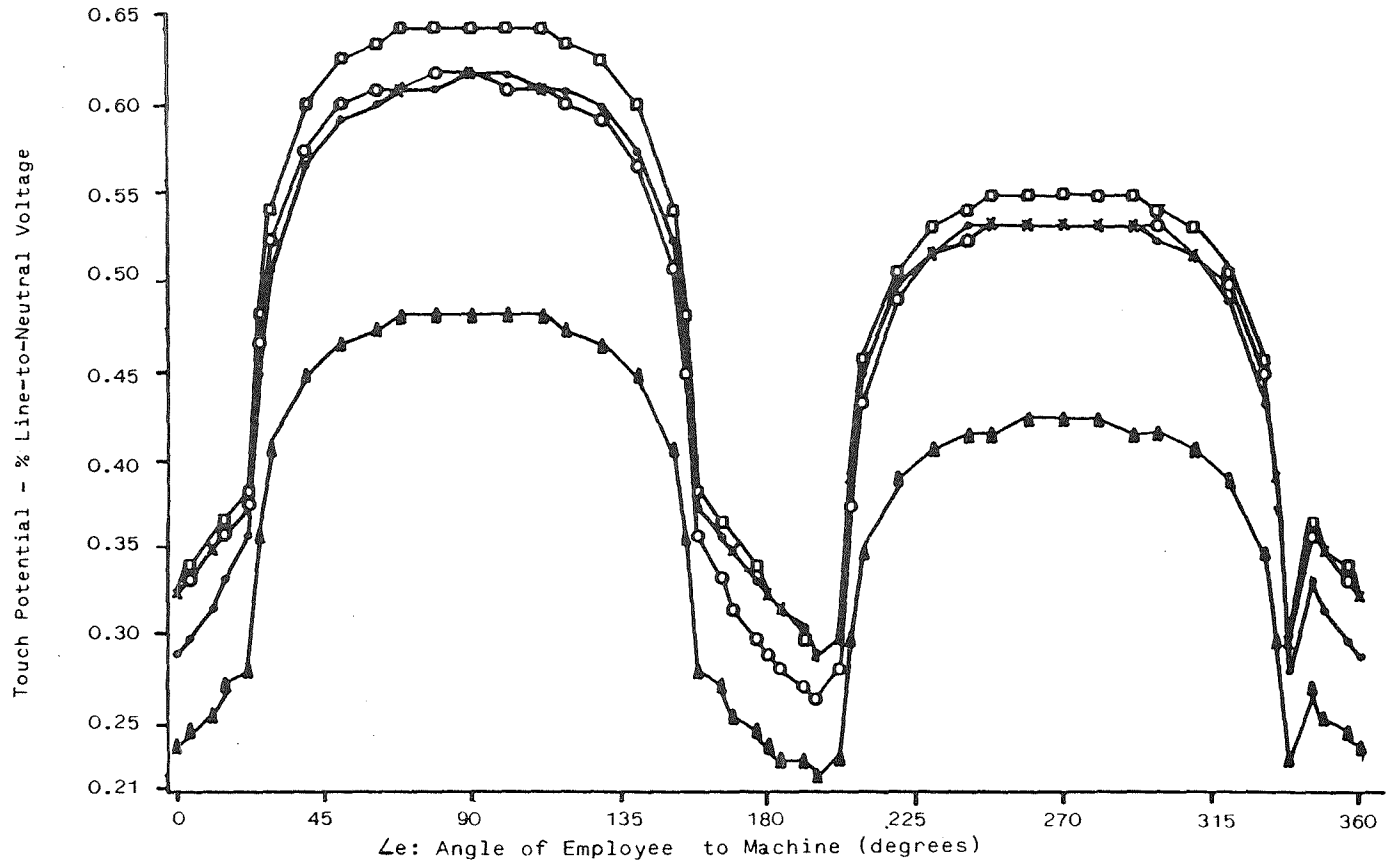

FIGURE 4.15 Touch Potentials Around a Double Hemisphere Machine for a Nearby Fault, Fault Near Narrow End



- $\angle b$  = Angle Ground Bed to Machine =  $0^\circ$
- ▲  $\angle b$  = Angle Ground Bed to Machine =  $90^\circ$
- $\angle b$  = Angle Ground Bed to Machine =  $180^\circ$
- ◻  $\angle b$  = Angle Ground Bed to Machine =  $270^\circ$
- × signifies that two or more points overlap

$R = 100 \Omega$   
 $\rho = 100 \Omega\text{-m}$

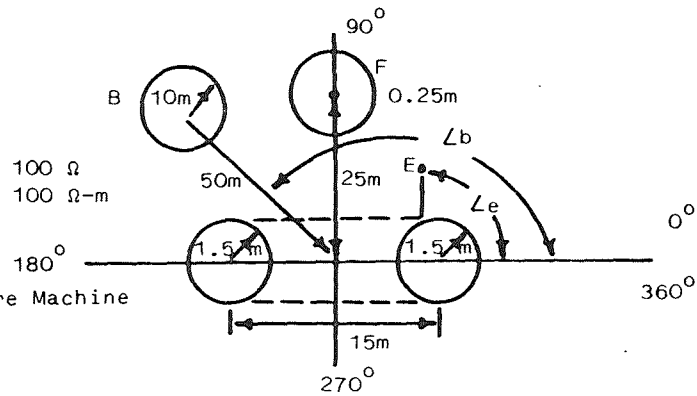

FIGURE 4.16 Touch Potentials Around a Double Hemisphere Machine for a Nearby Fault, Fault Near Long Side

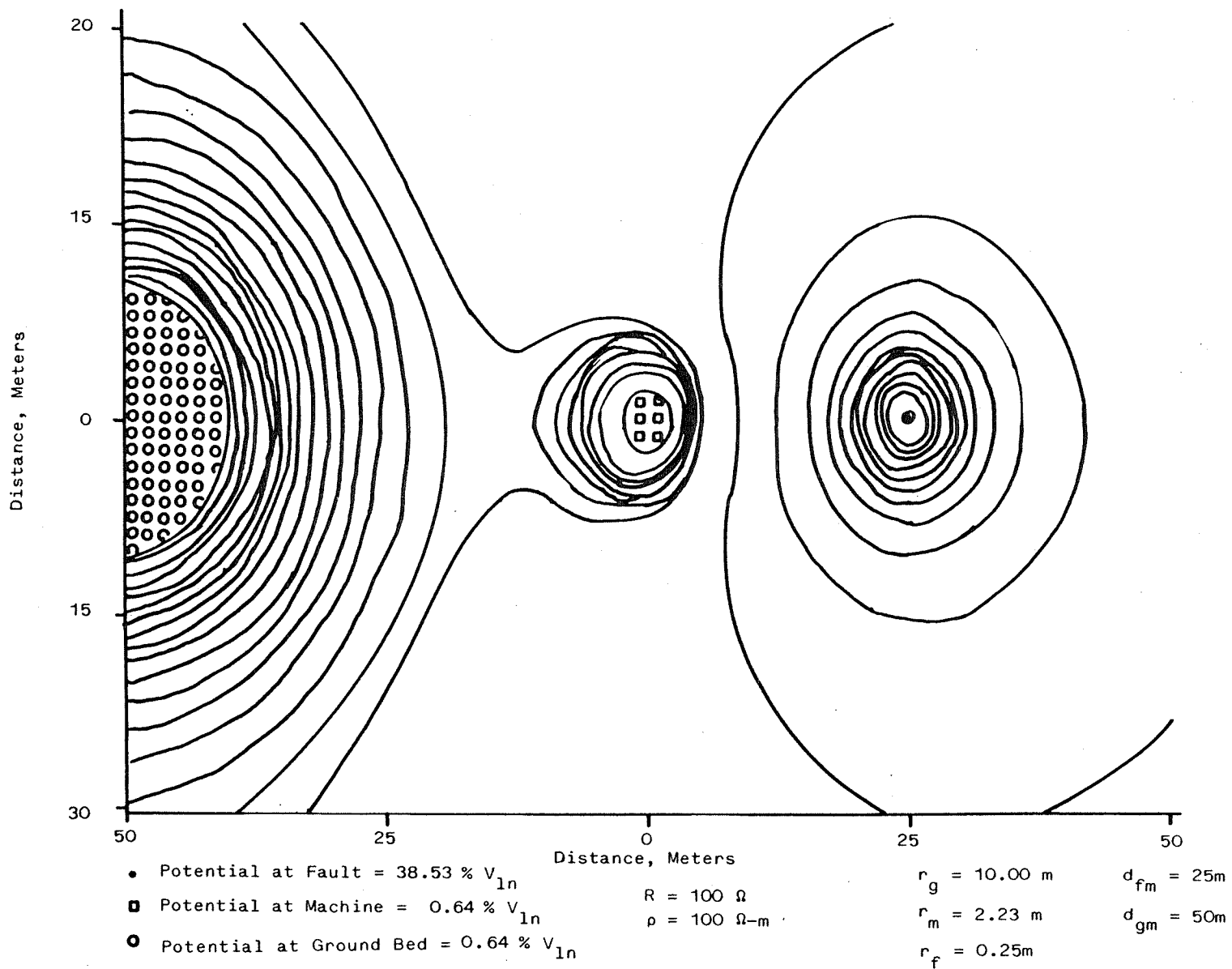

FIGURE 4.17 Potential Map, Single Hemisphere Machine

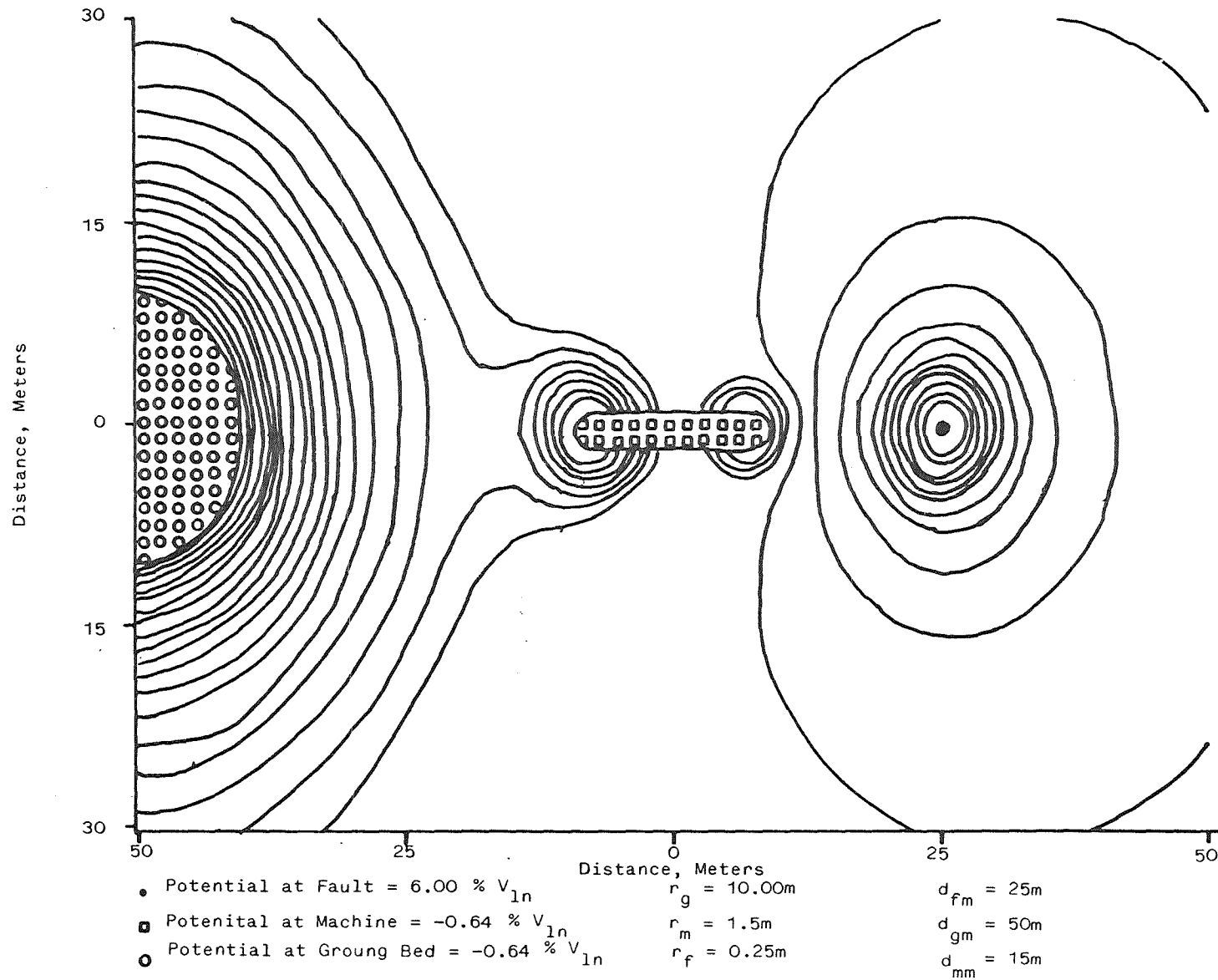

FIGURE 4.18 Potential Map, Double Hemisphere Machine, Fault Near Narrow End

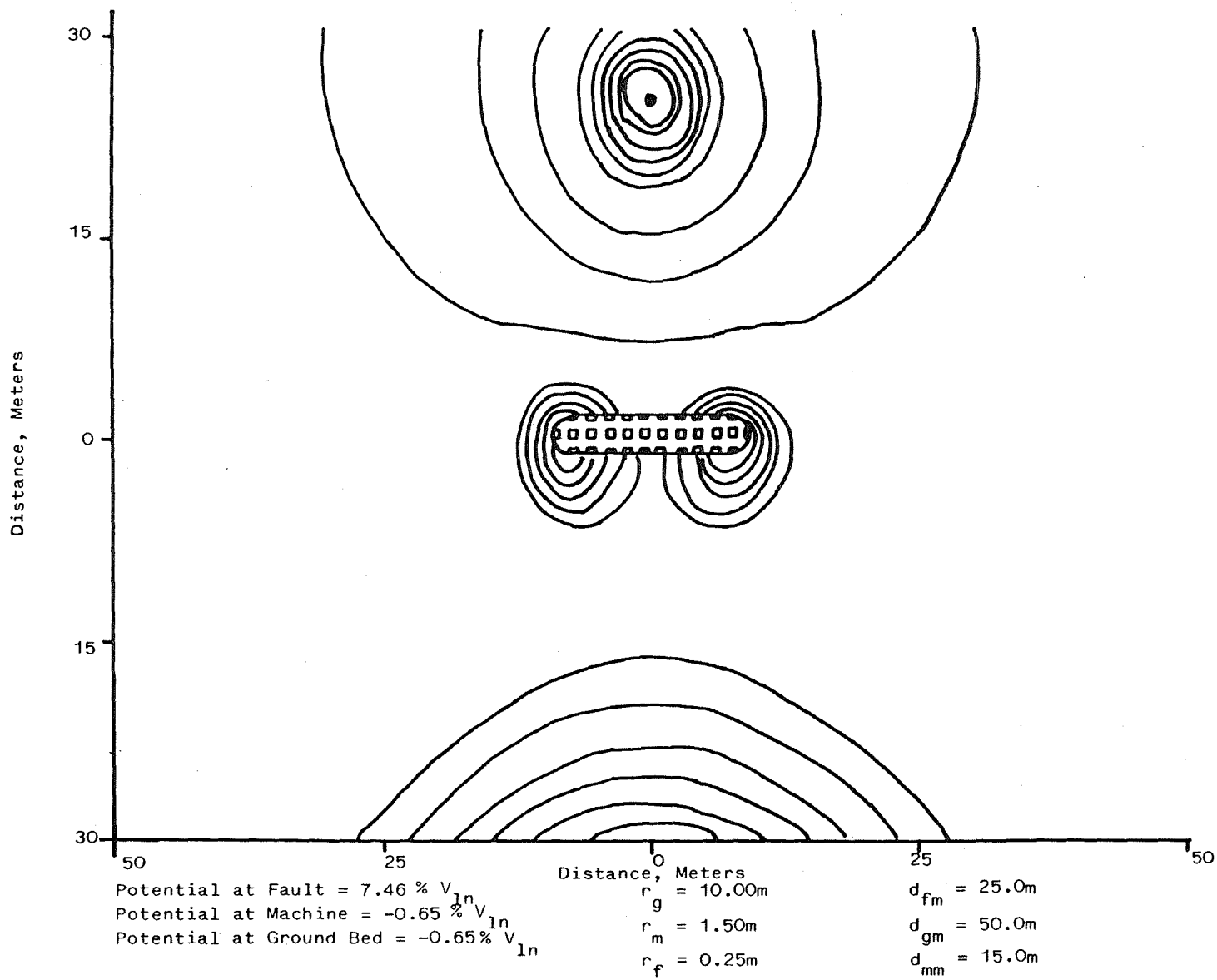

FIGURE 4.19 Potential Map, Double Hemisphere Machine, Fault Near Long Side

#### 4.4 IDENTIFICATION OF AREAS WITH HIGHEST TOUCH POTENTIAL

From Sections 4.2 and 4.3 it was shown that the touch potentials around a given machine are influenced most by these factors:

- 1) the distance from the machine to the fault,
- 2) the position of the ground bed in relation to the machine and the fault, and
- 3) the shape of the machine.

##### 4.4.1 Nearby Faults

The figures in Section 4.2 show that the maximum touch potential that occurs for a nearby fault is greater than the maximum touch potential that occurs for a distant fault under the same conditions. A comparison of the figures of Section 4.2.2 with the figures of Section 4.2.1 reveals that the maximum touch potentials for the nearby faults can be at least twice as large as the maximum touch potentials for the distant faults.

##### 4.4.2 Ground Bed Opposite Fault

In all of the figures of Section 4.2 the curve with the absolute maximum touch potential in each case is the one for the situation where the ground bed is located on the opposite side of the machine from the ground fault.

##### 4.4.3 Sharp Corners and Extensions of Machines

The curves and maps of the previous sections demonstrate clearly that potential gradients (and hence touch potentials) are large at the ends of an elongated machine, which are represented as two hemispherical contacts spaced some distance apart. However, the curves and maps do not show reduced gradients along the sides of the machine, a phenomenon we know to exist from our extensive field work. As stated earlier, the problem is that the elongated model machine only touches the earth at its two ends, whereas an actual machine would usually be in earth contact over its entire length. The modeling techniques used simply cannot represent the situations we would like to demonstrate.

The difficulty with the model helps to emphasize the main point of this section, however. That point is that the touch potentials around a machine are very dependent on the shape of the machine and the size, shape, and extent of its contacts with the earth. If a worker contacts an energized object in earth contact in an area where the machine has no extensive earth contact (such as at a sharp corner, directly under a large shovel which is supported only by tracks at the far corners, the end of a boom, etc.), then that worker is subject to high touch potentials. If the worker contacts the energized object in earth contact near where it does touch the earth over a wide area, then that worker is exposed to significantly lower touch potentials. Thus, sharp corners and extensions of machines must be considered the most dangerous shock hazard.

## CHAPTER 5 - DEVELOPMENT OF TEST PROCEDURE

Initially, the test procedure was conceived as covering touch and step potentials in both underground and surface mines. In any mine, there are two possible ground-fault mechanisms which generate shock hazards: (1) a fault close to the ground bed, which raises the potential of grounded equipment relative to the earth around the equipment, and (2) a fault close to a piece of grounded equipment, which raises the potential of the earth around the equipment relative to the equipment. The first mechanism causes no special problems for measurement for underground mines, as the overwhelming majority of underground mines have surface ground beds. The same procedures developed for surface mines can be used.

The second mechanism was more intractable: phase-to-earth faults can occur anywhere an energized conductor can touch the ground. For underground operations, this includes faults that occur underground and surface faults over shallow mines. To assess the hazards of these two types of faults, simulation of them is necessary. The underground fault can only be studied by carrying the resistance meter underground and injecting current at the hypothetical fault location. This problem is major, due to the inherent fragility of the instrument and the difficulty with driving measurement stakes in most mine floors. After examining this problem at great length, no way of avoiding the underground measurement was found. The only encouraging factor here is the relative infrequency of phase-to-earth faults underground; the lack of exposed phase conductors (except for trolley wires) contributes significantly to this. Downed trolley wires tend to result in phase-to-neutral faults, as they contact the rails.

Surface faults over underground mines, are even more of a measurement problem. The fault must be simulated on the surface, but the touch potentials measured underground. Because the fault simulation and touch-potential measurement are carried out with the same instrument, and both done simultaneously, this would be difficult. Fortunately, surface faults will cause underground shock hazards only in very shallow mines.

Analytical studies were attempted to determine the range of mine depths for which this fault condition would require measurement. Exact solutions appear not to exist; not only is the electromagnetics problem complicated for the homogeneous-earth case, but also the primary direction of current flow is across rock strata, which is the most non-uniform direction for resistivity variation. However, two results emerged from the analysis: the touch potentials are more severe underground than are the surface potentials for a fault of the same magnitude and separation. The underground potentials appear to be problems for mines which are roughly less than 100 feet deep.

Since the measurement problems were so great, it was decided to concentrate on the surface potentials due to surface faults. Underground earth potentials are relatively rare, and instrumenting them would have significantly raised the cost of test equipment.

This chapter explains the origin and background of the test procedure that is included as an appendix to this report. Because much of the

material here is supplemental to that appendix, this chapter may be used as a reference to explain the necessity of some less obvious sections of the procedure.

## 5.1 SAFETY AS THE CENTRAL ISSUE

Personnel making electrical measurements on power systems are ALWAYS subject to some risk of electrical shock. The fact that the measurements discussed here are to be made on that portion of an electrical system designed to prevent electrical injury does not remove the risk. As stated in the procedure: ANY METAL OBJECT OR WIRE CONNECTED TO A POWER SYSTEM SHOULD BE ASSUMED TO BE LETHAL UNTIL IT HAS BEEN TESTED FOR VOLTAGE.

The common misconception that all metal objects connected to the earth are 'grounded' and therefore safe to touch can be very treacherous. Earth currents, due to undetected ground faults or poor earth return connections (perhaps in some power system remote from the one under test), can cause these grounded objects to have dangerous step or touch potentials.

The limitations are listed in the beginning of the procedure. One of the more important issues that the procedure does not address is that of the ability of the grounding system to carry high fault currents.

Neither the ground-bed resistance method nor the technique described here tests the ability of the grounding conductors to carry the high currents of a phase-to-ground fault. Additional physical inspections or high-current tests should be performed to verify that the grounding system can carry these currents. The magnitude of possible fault currents can be found from the tests described in the last section of this procedure.

## 5.2 CHOICE OF INSTRUMENT

The meter chosen for making the measurements must be capable of producing voltage readings which are relevant and reproducible. In addition, the meter must be portable and as easy to use as possible, must survive the hostile mining environment, and must not be a source of hazardous potentials. Twelve possible candidate meters were considered, and information about their operation was sought. Table 5.1 shows the initial assessment made based on available literature and experience of the researchers with some of the devices.

As Table 5.1 indicates, four meters appeared to be candidates for making the desired measurements. It was then necessary to further evaluate them for suitability by subjecting them to performance tests.

### 5.2.1 Accuracy

The issue of accuracy is handled indirectly by the measurement procedure. Instead of demanding a specified accuracy (of range and

Table 5.1  
Instruments Considered for Use with  
Ground System Evaluation Procedure

1. Fann Instrument Operations - Houston, Texas  
Model 88C Resistivity Meter  
For measuring resistivity of liquids - not suitable
2. Bison Instruments, Inc. - Minneapolis, Minnesota  
Model 2390 Earth Resistivity System  
Price about \$7500 - too expensive
3. Bison Instruments, Inc. - Minneapolis, Minnesota  
Model 2350B Earth Resistivity Meter  
720 volts pk-pk maximum output - excessive shock hazard
4. Biddle Instruments - Blue Bell, Pennsylvania  
Megger Null Balance Earth Testers  
(Model 250241, battery powered)  
(Model 250220-2, hand cranked)  
both appear suitable
5. Biddle Instruments - Blue Bell, Pennsylvania  
Model ET-6, Direct Reading Ground Tester  
Cannot make four-terminal measurements - not suitable
6. Biddle Instruments - Blue Bell, Pennsylvania  
DET-2 Digital Earth Resistance Tester  
appears to be suitable
7. Geotronics Corporation - Austin, Texas  
ABEM Terrameter  
Price about \$7000 - too expensive
8. OYO Corporation - Houston, Texas  
YL-E1 Geoelectric Resistivity Meter  
1000 volt pk-pk output - excessive shock hazard  
Price about \$6800 - too expensive
9. Associated Research, Inc. - Chicago, Illinois  
Vibroground Earth Tester  
appears to be suitable
10. Chauvm-Arnaux, France  
Cannot make four-terminal measurements - not acceptable
11. Yokogawa - Japan  
Model YEW 3235 Earth Tester  
Cannot make four-terminal measurements - not acceptable

reading), the suggestion is made that a four-terminal, commercial meter, built for making ground-bed resistance measurements be used. There are two reasons for this: (1) the extra expense of four-terminal design is only used for the more accurate instruments, and (2) the complexities of the measurement problem limit the resolution of touch potentials to a much broader range than any of the meters we reviewed. To ensure that the measured potentials be relevant to the 60-Hz power system, the measurement frequency is specified to be less than 500 Hz, but not dc. Finally, for personnel protection, the open-circuit voltage (between the current terminals) is limited to less than 100 volts.

### 5.2.2 Effects of Stray Current

The measurement procedure was designed around the constraint that the power system need not be shut down during the tests. Although removal of power does not necessarily eliminate stray currents, leaving the power connected does increase the probability of measurement problems. Our past field experience has shown that some instruments will not survive an attempted measurement in the presence of a few amperes of stray current, and less than one ampere can cause erratic readings. The constraint that the meter work reliably with up to 10 amperes of stray ac or dc current seems to be adequate, from our field tests, to insure good measurements in the electrically hostile mining environment.

A series of field tests were done to investigate the sensitivity to stray current of the DET-2\* instrument chosen for the procedure development. These tests are summarized in Table 5.2, and serve as proof that an instrument does exist that can carry out the measurements in the procedure. A second test comparing the DET-2 to three other earth resistivity meters is summarized in Table 5.3. The DET-2 is the only meter, of the four tested, to provide accurate measurements in stray current fields greater than two amperes.

### 5.3 CONSTRUCTION OF INTERCONNECTED GROUND SYSTEM AT WEST VIRGINIA UNIVERSITY (WVU)

The computer studies discussed in Chapter 4 had to be compared with actual measurements. This is necessary because only the most simple cases can be modelled with any confidence, and any practical mining operation is far from having a simple geometry. This section describes a representative sample of measurements which were made to confirm that the general trends found in the computer models were indeed valid. These tests were done on the WVU ground bed, located near the Engineering Sciences Building. As part of this verification procedure, a second ground bed was constructed near the original bed.

---

\*Reference to specific brands, equipment, or trade names in this report is made to facilitate understanding and does not imply endorsement by the Bureau of Mines.

TABLE 5.2  
Meter Stray-Current Test

Current (A):	Range:	Reading (ohms):	Filter:	Comments:
0.0	Low	3.58	Out	
	Normal	3.60	Out	
	High	3.59	Out	
2.6	Normal	2.57 to 2.67	In	Erratic
	High	2.54 to 2.65	In	Erratic
0.0	Normal	2.57	Out	
	High	2.56	Out	
3.25	Normal	2.58 to 2.72	In	Erratic
	High	2.54	In	
0.0	Normal	2.54	Out	
	High	2.53	Out	
4.45	Normal	2.53 to 2.68	In	Erratic
	High	2.48	In	
0.0	Normal	2.51	Out	
	High	2.51	Out	
6.3	Normal	2.43 to 2.62	In	Erratic
	High	2.41	In	
0.0	Normal	2.49	Out	
	High	2.48	Out	
7.1	Normal	2.12 to 2.44	In	Erratic
	High	2.40	In	
0.0	Normal	2.48	Out	
	High	2.47	Out	
8.0	High	2.38	In	
0.0	Normal	2.46	Out	
	High	2.45	Out	
9.1	Normal	2.35	In	Stable
	High	2.36	In	
0.0	Normal	2.47	Out	
	High	2.44	Out	
10.2	Normal	2.35	In	Stable
	High	2.33	In	
0.0	Normal	2.45	Out	
	High	2.44	Out	
11.4	Normal	2.30 to 2.34	In	Slightly erratic
	High	2.30	In	
0.0	Normal	2.45	Out	
	High	2.42	Out	
12.3	Low (Indicated Input Noise)		In	
	Normal	2.29 to 2.31	In	Slightly erratic
	High (Indicated Spike Res.)		In	
0.0	Normal	2.44	Out	
	High	2.42	Out	

Note: tests are listed in chronological order; zero-current tests were repeated to check for varying earth resistance.

Table 5.3  
Stray Current Test of Four Resistance Meters

Stray Current (Amp)	DET-2* Current Setting	Filter Setting	Biddle* Earth Tester (Battery Powered)	Biddle* Earth Tester (Hand Cranked)	Model 2300
0.0	L-2.27 N-2.29 H-2.29	Out Out Out	2.26	2.30	2.8
0.94	L-2.23 N-2.26 H-2.25	Out Out Out	2.19 Null Meter Refl. to (+) side w/o test button pushed	2.31 Hard to get Meter to Balance; must turn slow	36.0 - 38.0 Very Erratic
0.0	L-2.26 N-2.27 H-2.27	Out Out Out	2.23	2.27	2.5
1.40	L-2.20-2.23 N-2.24 H-2.25	In Out Out	2.23 Null Meter Defl. (+) side w/o test button pushed, needle waivers *1/3 division	≈2.15 Needle won't stabilize can't get good reading	Reading is off scale, useless
0.0	L-2.24 N-2.26 H-2.25	Out Out Out	2.21	2.24	2.5
2.0	L-2.24 N-2.22 H-2.22	Out In Out	2.14 Null meter waivers * 1/3 division	Can't get needle to stabilize on null meter	
0.0	L-2.24 N-2.25 H-2.25	Out Out Out	2.21 Most significant digit knob broken	2.23	

Current Setting L - Low  
N - Normal  
H - High

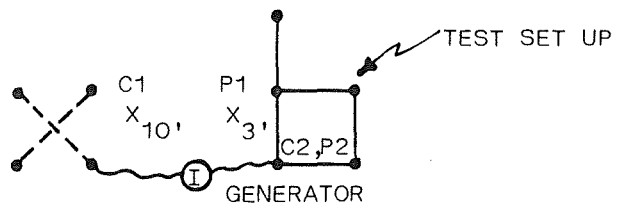

\*Reference to specific brands, equipment, or trade names in this report is made to facilitate understanding and does not imply endorsement by the Bureau of Mines.

### 5.3.1 Confirmation of Computer Analysis of Equations

Figure 5.1 is a standard fall-of-potential curve to find the resistance of the original ground bed. As shown on the curve, the ground-bed resistance is approximately 2.8 ohms. It is interesting to compare this to the actual touch potentials, because it indicates that 2.8 volts of touch potential would exist for every ampere of fault current circulating through the bed. Although this is a very conservative number for distant faults, it will be seen here (as predicted by the computer study) that this value can underestimate touch potentials for nearby faults.

Figure 5.2 is a map of touch potentials around the ground bed for a fault occurring 324 feet from the bed, as shown. Even with the fault this distant from the bed, the highest touch potentials are found on the point of the ground bed nearest to the fault. The maximum touch potential is 1.181 volts/ampere of fault current, and the minimum is 0.830. The minimum is found in the middle of the back side, furthest from the fault. Both numbers are substantially lower than the 2.8 ohms predicted by the resistance measurement above, largely because the earth near the ground bed is elevated in potential, being much closer to the ground-bed potential than the potential of remote earth. This result is exactly predicted by the computer study in Section 4.2.1.

Figure 5.3 is a summary of several different fault situations. The current probe was placed in different positions to cause maximum touch potentials, and the potential probe placed to measure this maximum potential. The results here match the predictions of Section 4.2.2.

Figure 5.4 is a test done with the newly constructed adjacent ground bed as the return electrode. The effect of the diffuse fault-current electrode is remarkable in that the highest touch potentials do not occur on the side closest to the fault, but rather on the closest corner of the bed to the fault. This result shows the limit of the computer study, which could not model such a complex system.

Overall, the field tests done here provided great confidence in the ability of the computer analyses to predict the worst-case touch potentials. The only problems encountered occurred when the physical situation was much more complicated than the model.

### 5.3.2 Estimation of Fault Current

In the early stages of procedure development, a critical problem was the determination of possible fault current. The touch potential/unit fault current determined by the procedure must be multiplied by this fault current to obtain the actual touch potentials. A solution to this problem appeared during the field tests done at the WVU ground bed. The staged-fault tests were done using a portable generator with a nominal output voltage of 120 volts. It was necessary to limit the fault current to less than 2 amperes for the digital ammeters which were used. It was possible to measure the total resistance seen by the 120 V source, using the same test instrument that was purchased for the touch-potential measurements. The same technique was shown to be

Current Probe @ 100'

Probe Location	Resistivity (in $\Omega$ 's)
10'	1.694
20'	2.04
30'	2.24
40'	2.41
50'	2.58
60'	2.77
70'	2.99
80'	3.34
90'	4.43

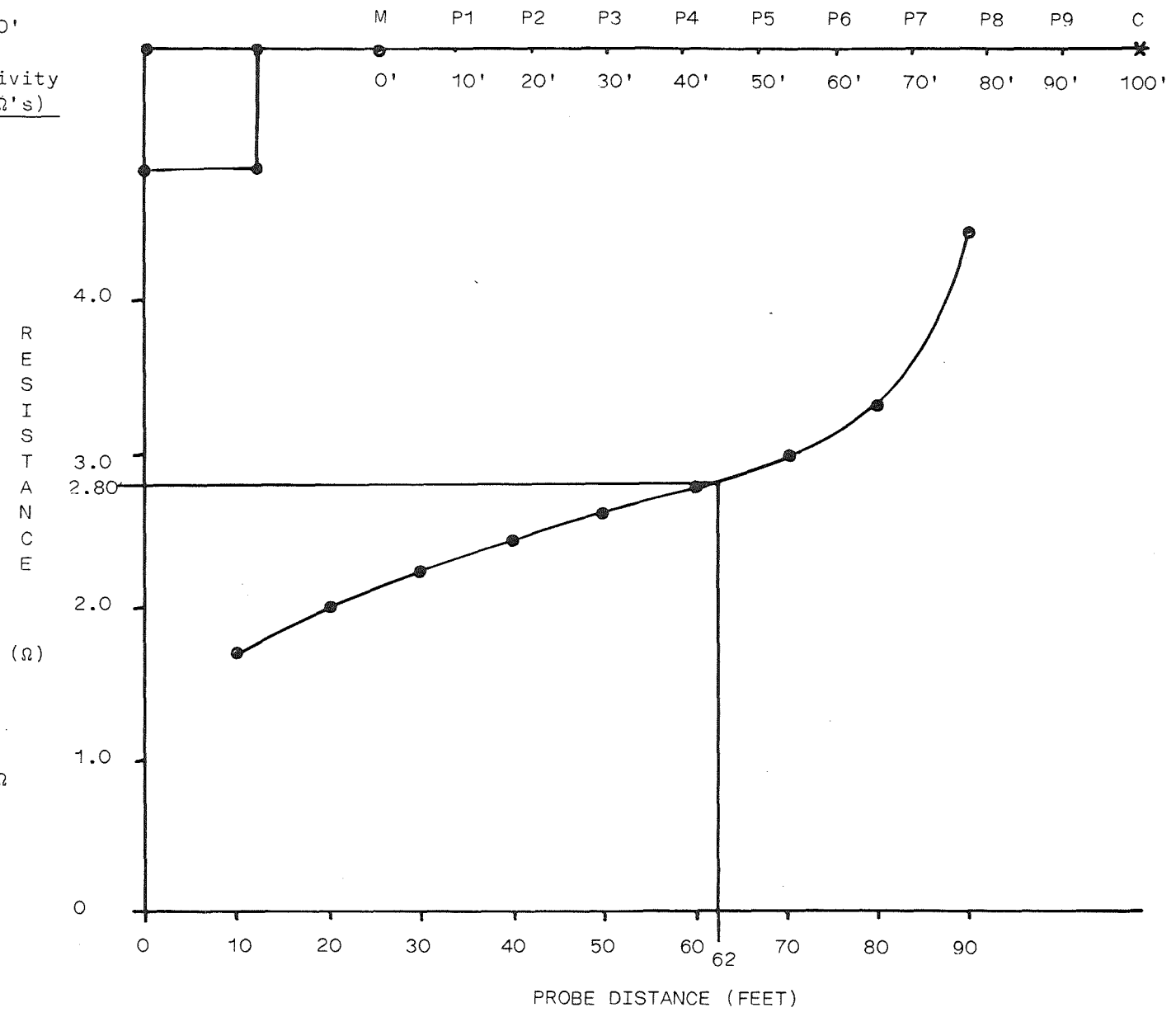

Ground Bed Resistance = 2.80  $\Omega$

FIGURE 5.1 Resistance of WVU Ground Bed, Fall-of-Potential Method

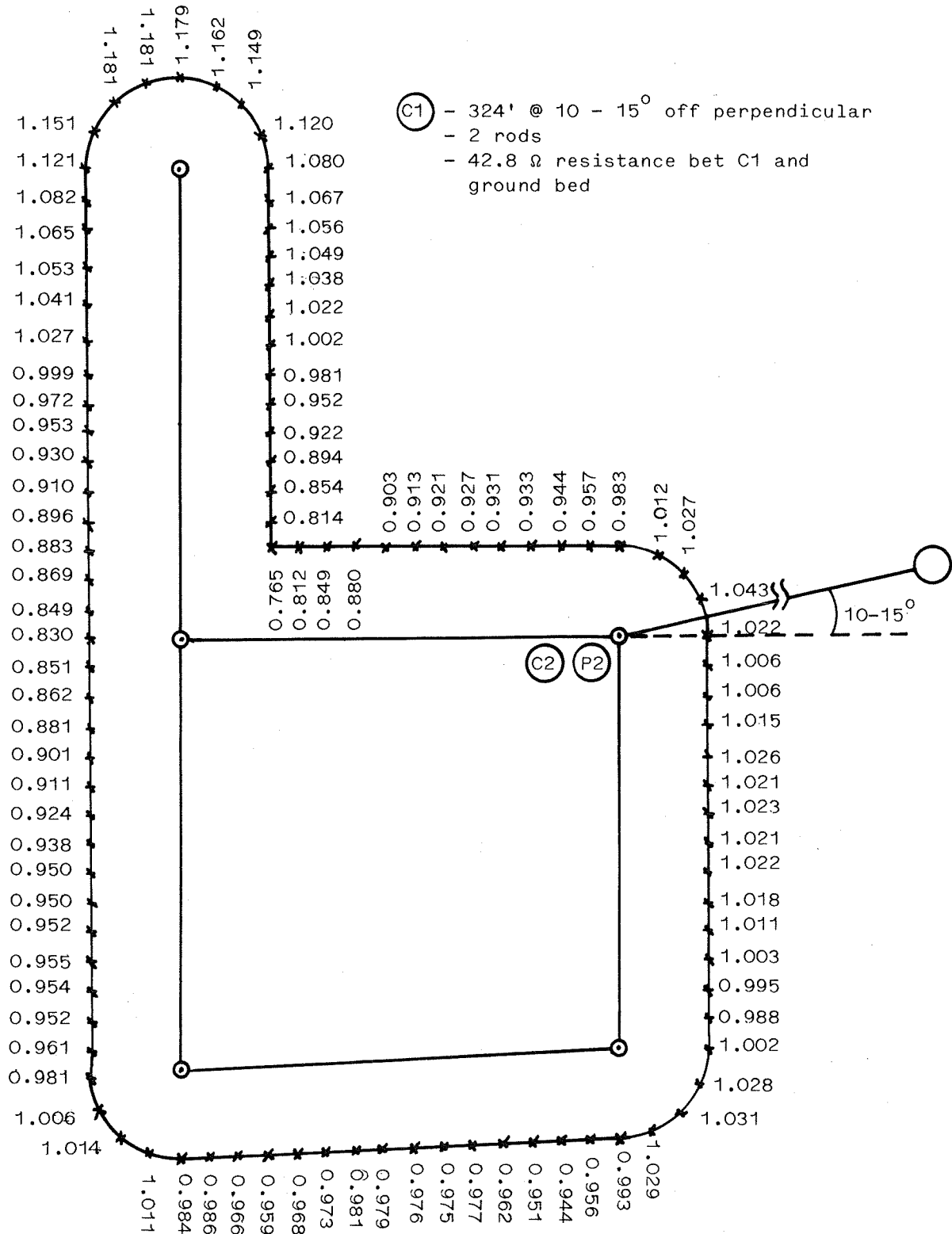

FIGURE 5.2 Touch Potentials on WVU Ground Bed, Distant Fault

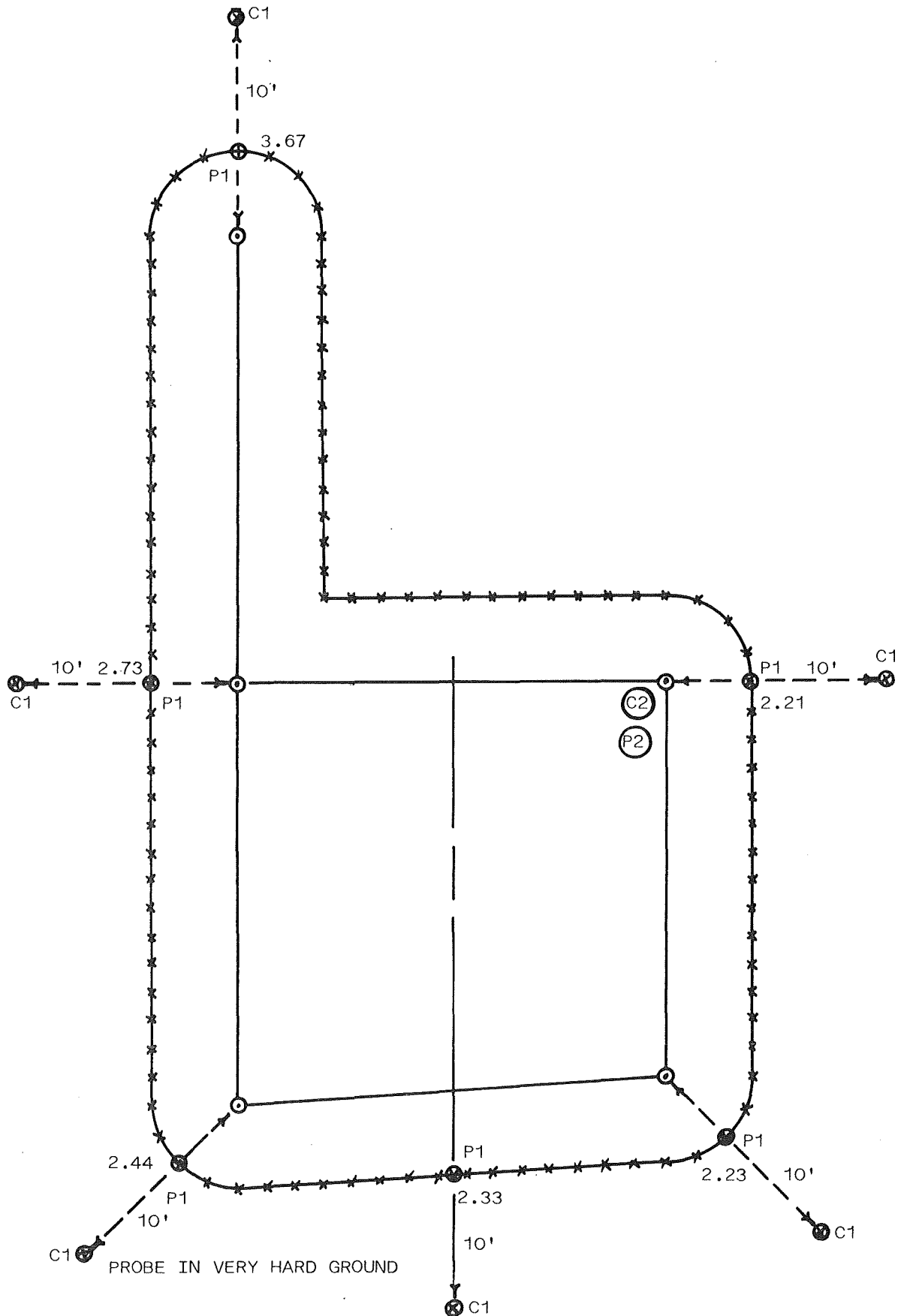

FIGURE 5.3 Maximum Touch Potentials for Faults Near the WVU Ground Bed

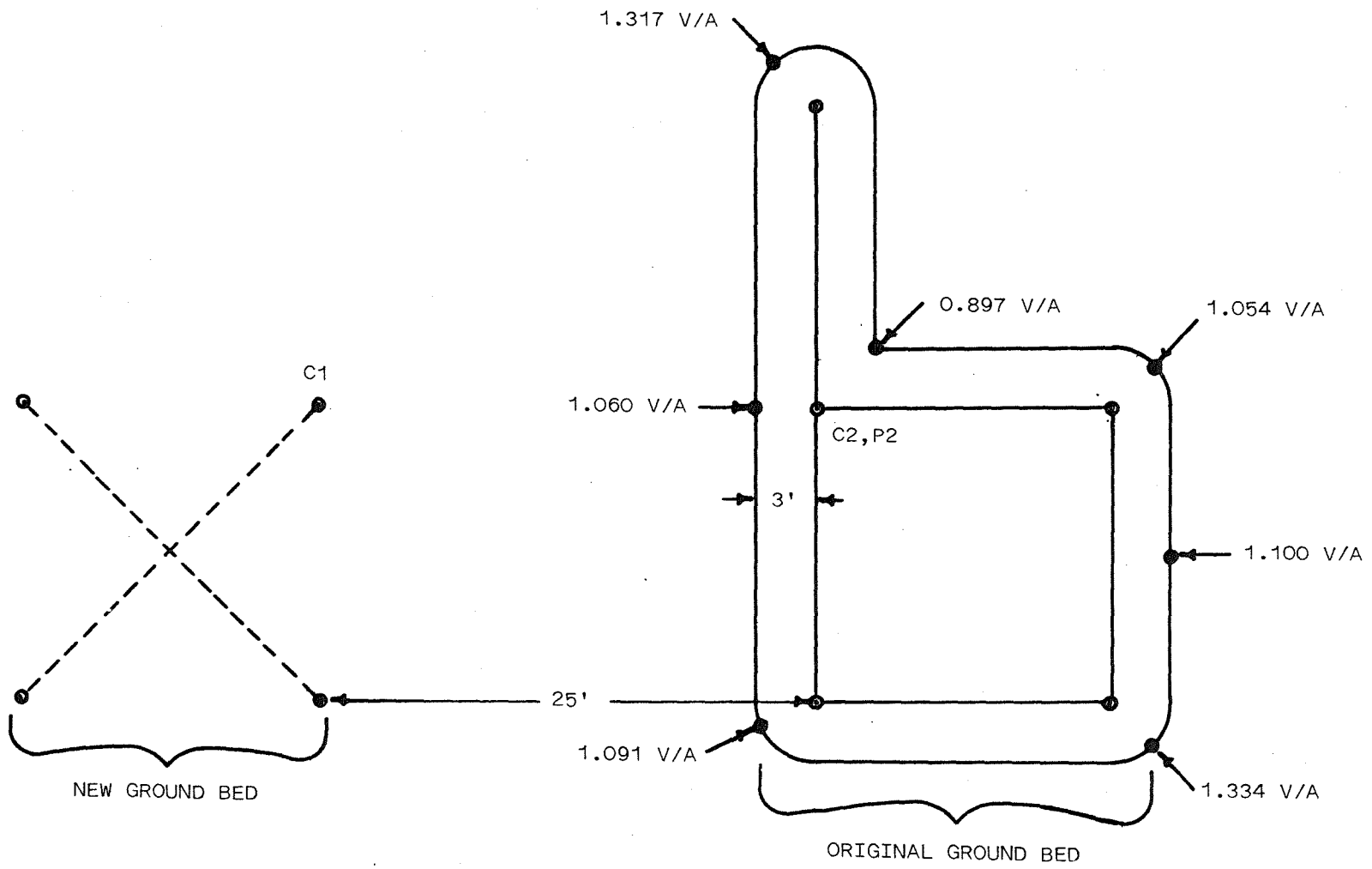

FIGURE 5.4 Touch Potentials with New Ground Bed as Return Current Electrode

practical for actual mining operations. By measuring the resistance between the neutral ground connection and a conductor lying on the earth, the appropriate ground-fault current can be obtained by dividing the line-to-neutral voltage by this resistance. A detailed description of the mechanics of this procedure are contained in Appendix B.

#### 5.4 COMPARISON OF PROCEDURE WITH STAGED-FAULT TESTS

To have any confidence that the procedure determined touch potentials which could be correlated with actual fault conditions, a series of staged-fault tests were done with the same fault locations as those used in the touch-potential measurement with the meter. The results are summarized below.

Two independent sets of measurements were made, simulating faults distant from the WVU ground bed as well as one close to the bed. For both types of faults, the measured mutual resistances (volts of touch potential per ampere of fault current) were confirmed by actual staged faults using a portable generator.

There was some concern prior to the field test that the series impedance of the lead wires would adversely affect the comparison of the measurement technique with the staged-fault measurement. The concern is that the resistance meter measures only the real part of the mutual impedance, whereas the division of touch voltage by fault current necessarily yields the magnitude of the entire impedance. This concern was groundless; very good agreement was obtained between the measurement technique and the staged-fault test.

The first test involved a ground fault arbitrarily placed at 67 feet from the ground bed. For this situation, for a person on the side of the ground bed closest to the fault, the test instrument indicated a mutual resistance of 0.85 ohms (0.85 volts of touch potential per ampere of fault current). With a staged fault of 1.62 amperes, a touch potential of 1.42 volts was measured. This voltage and current correspond to 0.877 volts per ampere of fault current. With the person on the far side of the ground bed from the fault, the instrument indicated 0.952 ohms, while 1.60 volts were measured with the same fault current of 1.62 amperes. The ratio of voltage to current, 0.988, was in good agreement.

With the situation of a fault 10 feet from the corner of the ground bed, the measurement technique predicted a touch potential of 1.175 volts per ampere. The staged fault test yielded 1.96 volts of touch potential for 1.62 amperes, or 1.210 volts per ampere. The last test was a worst-case condition where the ground fault was made 10 feet from the middle of the long side of the ground bed. The meter indicated 2.60 volts per ampere, while the staged fault indicated 4.40 volts and 1.63 amperes, or 2.70 volts per ampere.

## CHAPTER 6 - EVALUATION OF TEST PROCEDURE

The test procedure developed in Chapter 5 was tested in the field at two non-metal surface mines. The desire was to examine the application of the touch potential test under actual field conditions.

### 6.1 DESCRIPTIONS OF MINES VISITED

Two surface mining operations were visited to test the touch potential measurement procedure. The first mine visited was a New England granite quarry. The layout of this mine is shown in Figure 6.1. Only the shop, some lights and a dewatering pump use electric power at this mine. Consequently, only one substation is used to supply power to the mine. The substation converts 13.2 kilovolt line voltage from the utility to 570 volts which is distributed to the mine. The supply transformers are connected delta-delta and are ungrounded. All water pipes are grounded to a single driven-rod ground bed located near the shop. The soil in this area is very thin, especially near the quarry pit, and has a very high resistivity, often exceeding 100,000 ohm-meters.

The second mine visited, shown in Figure 6.2, was a traprock mine located in eastern Pennsylvania. All of the mining equipment in the pit is diesel powered. Electrically powered equipment included a primary crusher, two crushing plants and an asphalt plant. There is one main substation that supplies power to the entire mine, two smaller substations that supply power to the asphalt plant and a bank of transformers that supplies power to the crushing plants. The main substation transforms 33 kilovolts from the utility to 4160 volts for distribution throughout the mine. The main transformers are connected delta-wye. The transformers at the crushing plant convert the 4160 volts mine supply to 480 volts to be used by the crushing equipment.

### 6.2 FIELD DATA TAKEN

Below are the results of the touch potential measurements taken at the granite quarry and the traprock quarry.

#### 6.2.1 Granite Quarry

The measurement instrument and procedure successfully proved themselves in the field at the granite quarry, in the face of two major obstacles. The first of these was the extraordinarily high earth resistivity. In some places, this resistivity could not even be measured, exceeding 300,000 ohm-feet (100,000 ohm-meters) in the granite dust near the pit. Under these circumstances, the stakes usually employed for current-return electrodes were completely ineffective. Even connecting three of these stakes in parallel did not result in a sufficiently low impedance for the test instrument to circulate current through the earth.

Making the usual ground-bed resistance tests in these circumstances would have been impossible. The fall-of-potential method depends on a

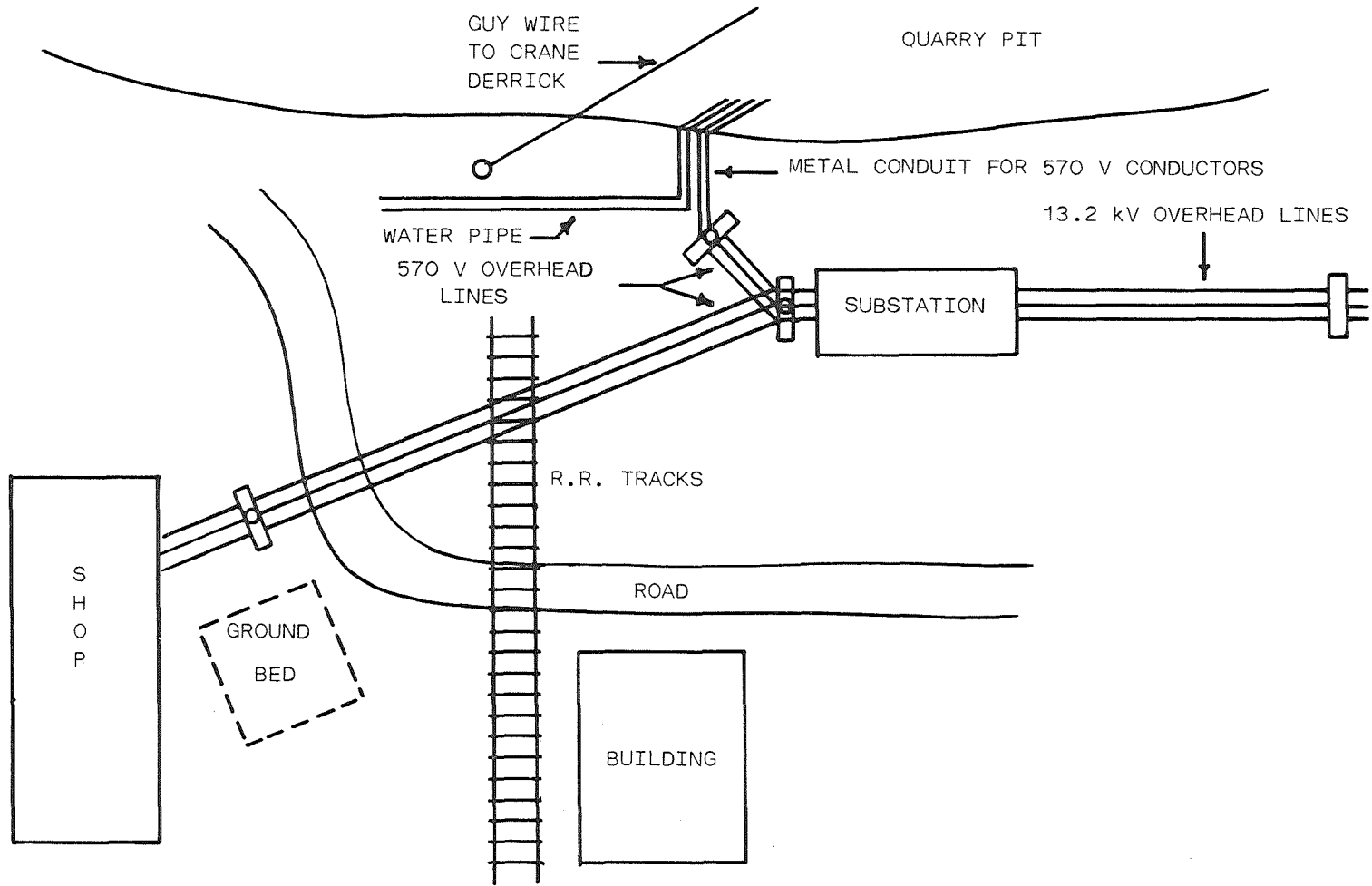

FIGURE 6.1 Granite Quarry

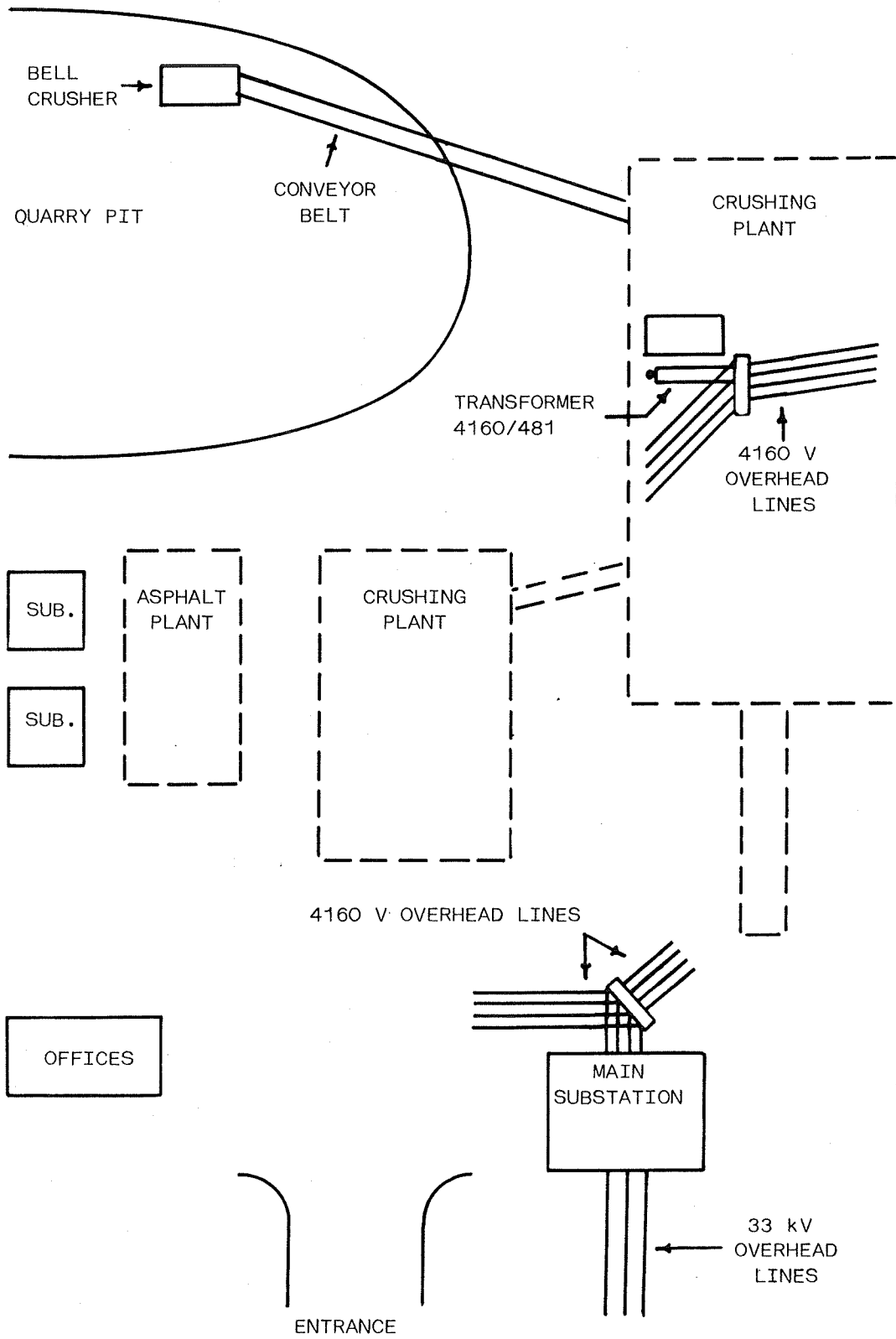

FIGURE 6.2 Traprock Quarry

point-source current return, which could not have been created. However, the new test procedures are designed to measure the worst-case touch potentials, which are due to the highest fault currents expected. When phase conductors come in contact with large metal objects, half-buried in the earth, phase-to-earth currents flow which are much larger than those due to a conductor merely lying on top of the earth, or through a small stake driven into the earth. At the granite quarry, in three important instances, such large metal objects were found. These metal objects (railroad tracks, a metal power pole base, and buried wire rope) were precisely the current-return electrodes required by the procedures because of their associated worst-case potentials; at the same time, they made the measurement possible because they allow enough current to flow for the instrument to work.

The second obstacle came from the mine power system. The measurement procedures are designed to predict the touch potentials resulting from a line-to-ground fault on a system with some form of neutral grounding. The granite quarry had an ungrounded delta-delta connection on the supply transformers; this design results in little, if any, current flowing from a single line-to-ground fault. Although this did not in any way interfere with performing the required measurements, it does affect the interpretation of those measurements. The touch potential calculations could be used with either the line-to-line or line-to-neutral voltages on the present system. Using the line-to-neutral voltages would yield the touch potentials that would be encountered if the current system would be converted to one that was neutral-grounded. Perhaps more realistically, if the line-to-line voltages are used, the touch potentials yielded are the maxima that could result from a phase-to-earth fault following a phase-to-ground fault on a different phase. This last assumption was used in the calculations below.

The first set of measurements were taken at a substation supplying the mining operation and are shown in Figure 6.3. A length of steel cable, at least 25 feet long, was found partially buried in the earth 73 feet from the substation. As this cable was also within 25 feet of the 13.2-kilovolt overhead line from the substation, the cable was used as the return electrode for current circulated between it and the substation ground. Touch potentials were measured at the fence surrounding the substation.

The point of maximum touch potential was found using the measurement procedure. This was 24.7 volts for a 1-ampere fault, occurring on the nearest side of the substation to the fault. Next, the point of maximum touch potential was exhaustively sought with closely-spaced potential measurements. The maximum value determined by the measurement procedure was found to be the true maximum; that is, the procedure worked. The fault impedance was determined by the measurement procedure to be 15 kilo-ohms. This translates to a maximum fault current for this situation of 0.88 amperes, and a maximum touch potential of 21.7 volts. The high resistance, and corresponding low current and touch potential, are due to the extremely high resistivity.

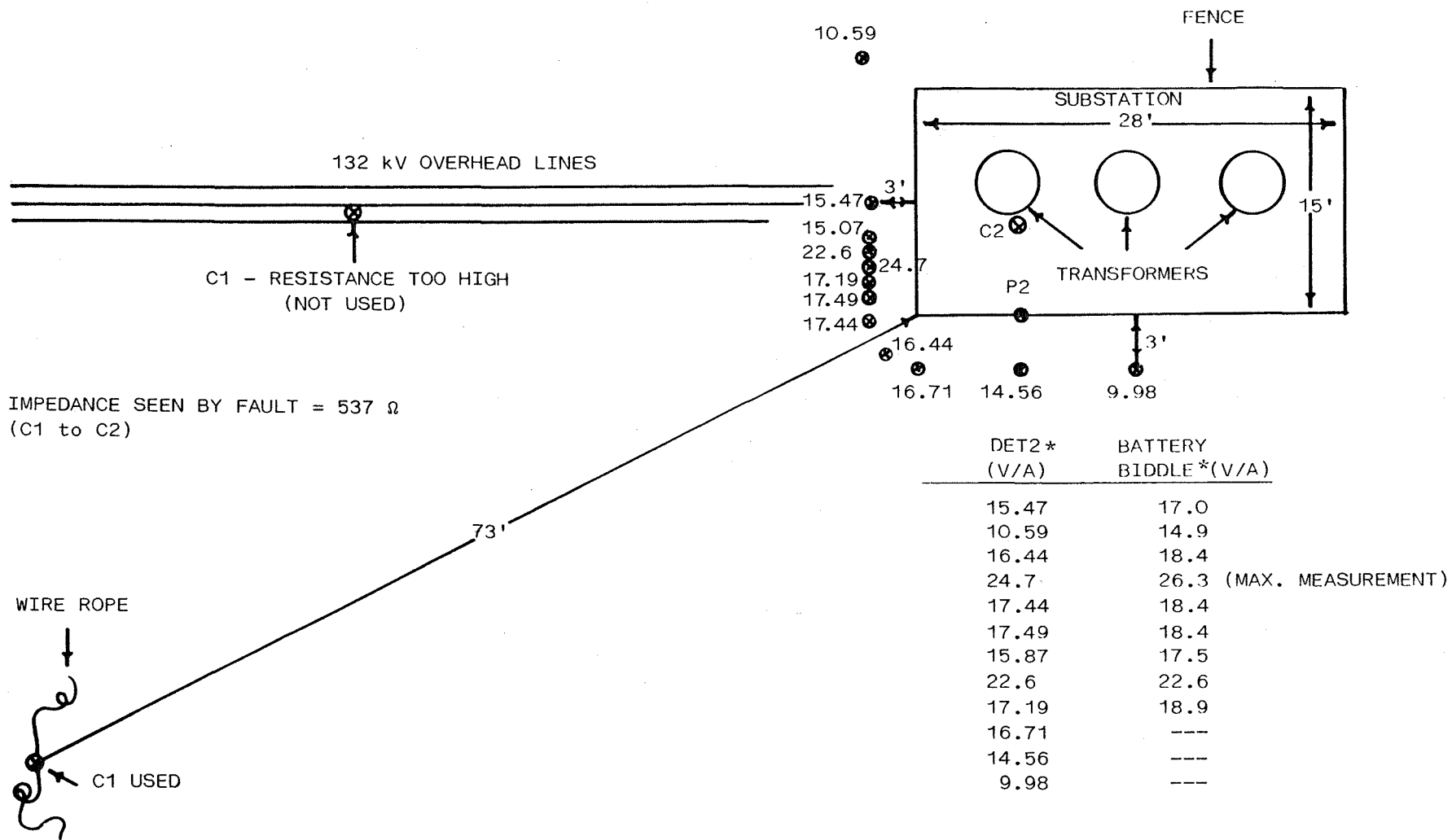

FIGURE 6.3 Touch Potential Measurements at Granite Quarry Substation

*\*Reference to specific brands, equipment, or trade names in this report is made to facilitate understanding and does not imply endorsement by the Bureau of Mines.*

Measurements were also made with a less expensive Biddle Megger 250241\* battery-operated earth tester. These readings were somewhat higher in magnitude because of noise problems, but they identified the same location as being most dangerous.

The next two series of measurements were done simulating faults far from the ground bed. In the first series, shown in Figure 6.4, a fault was hypothesized as happening near one of several guy wires on a derrick tower in the center of the pit. The potential of the guy wires was found to rise 0.304 volts/ampere of fault current, relative to the ground bed. The minimum fault impedance was found to be 4.33 ohms (the metal structure here was much more extensive) so that the maximum voltage on the guy wires could have been as high as 40 volts.

The second series, shown in Figure 6.5, was similar, except that the fault was hypothesized to occur to the railroad tracks which passed under the 570 volt line. Here the maximum touch potential on the rails is illustrated in Figure 6.5(a) and was found to be 129.4 volts/ampere. With a measured fault impedance of 163.4 ohms, this translates to a touch potential of 451.4 volts. This potential is very dangerous, but not unexpected since it corresponds to a person touching the rail while a live phase conductor is in contact with it. It also presumes a previous phase-to-ground fault. Other measurements illustrated in Figures 6.5 (b), (c), (d), and (e) yielded smaller touch potentials.

All the measurements taken at the granite quarry encountered high levels of input noise and stray ground currents. Consequently, it was required to engage the noise filter in the meter in all measurement cases in order to obtain consistent measurements.

### 6.2.2 Traprock Quarry

There were no obstacles to the measurement procedure encountered at the traprock quarry. No prohibitive earth resistivities were encountered and the most likely worst-case faults were readily identified. The power system at the traprock quarry had a grounded neutral.

The first set of measurements was taken at the main substation and is illustrated in Figure 6.6. The overhead power line was assumed to come in contact with the earth 21.5 feet from the fence surrounding the substation. To simulate this fault condition, a single metal-stake electrode was driven into the earth at point C1, as shown in the figure. Following the measurement procedure, the maximum touch potential was found to be 1.05 volts/ampere, and it was located at the center of the side of the substation nearest the fault. A series of measurements taken all along the fence at the substation confirmed the maximum touch potential found. The impedance seen by the fault was measured to be 1634 ohms. For a fault from the 33 kilovolt overhead lines the fault current would be 20.2 amperes.

---

\*Reference to specific brands of equipment or trade names in this report is made to facilitate understanding and does not imply endorsement by the Bureau of Mines.

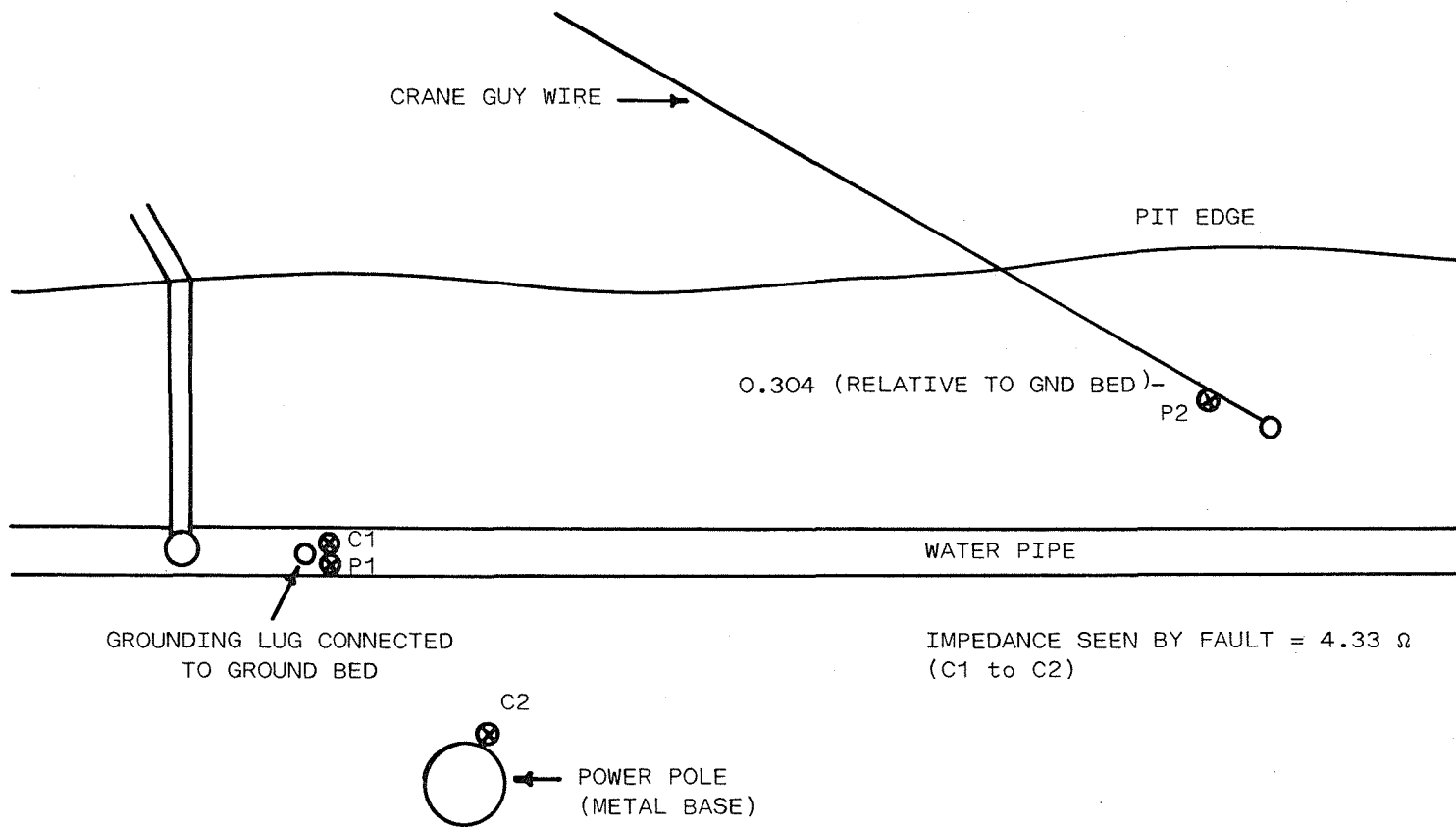

FIGURE 6.4 Touch Potential Measurements at Crane Guy Wire, Granite Quarry

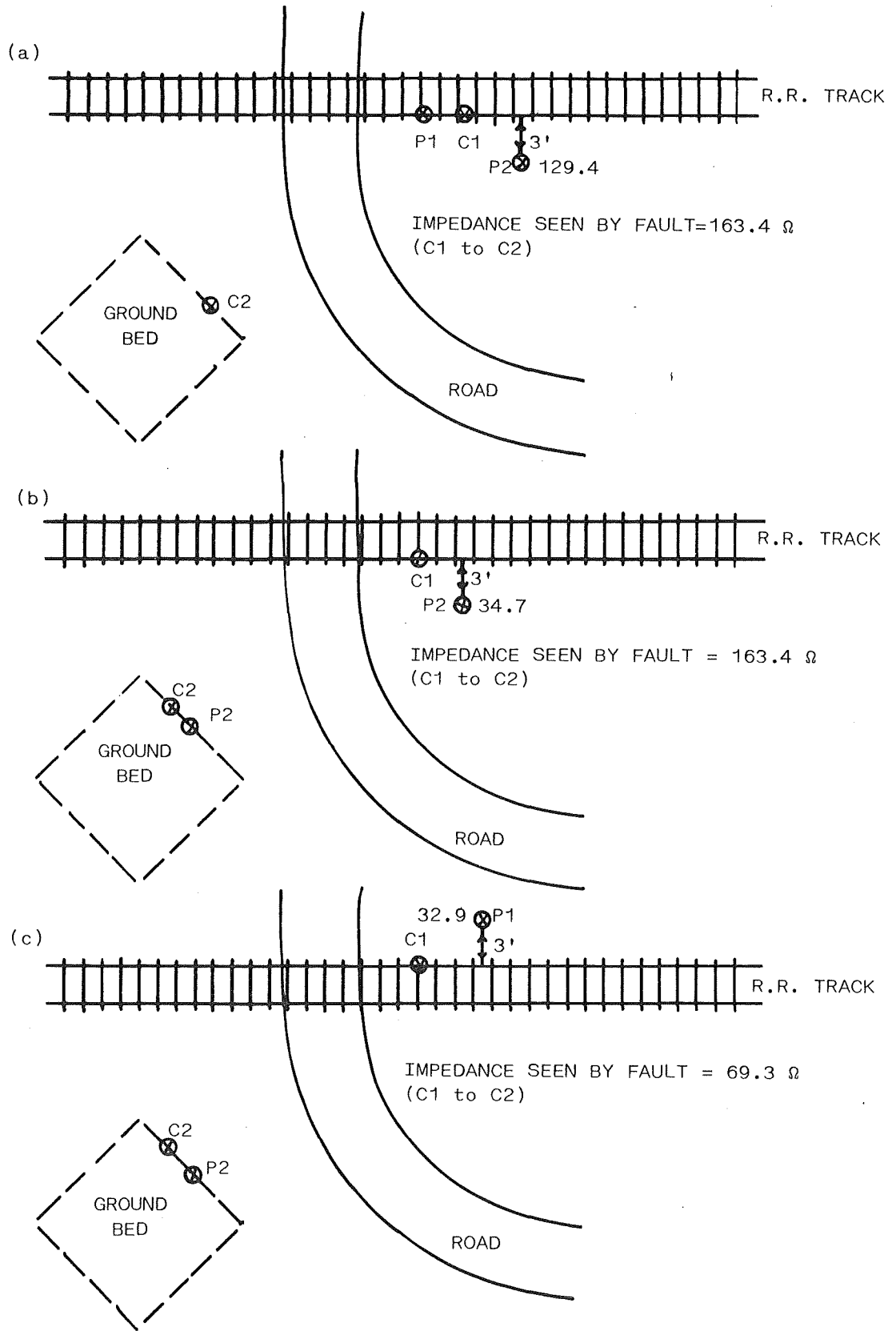

FIGURE 6.5 Touch Potential Measurements at Railroad Track, Granite Quarry

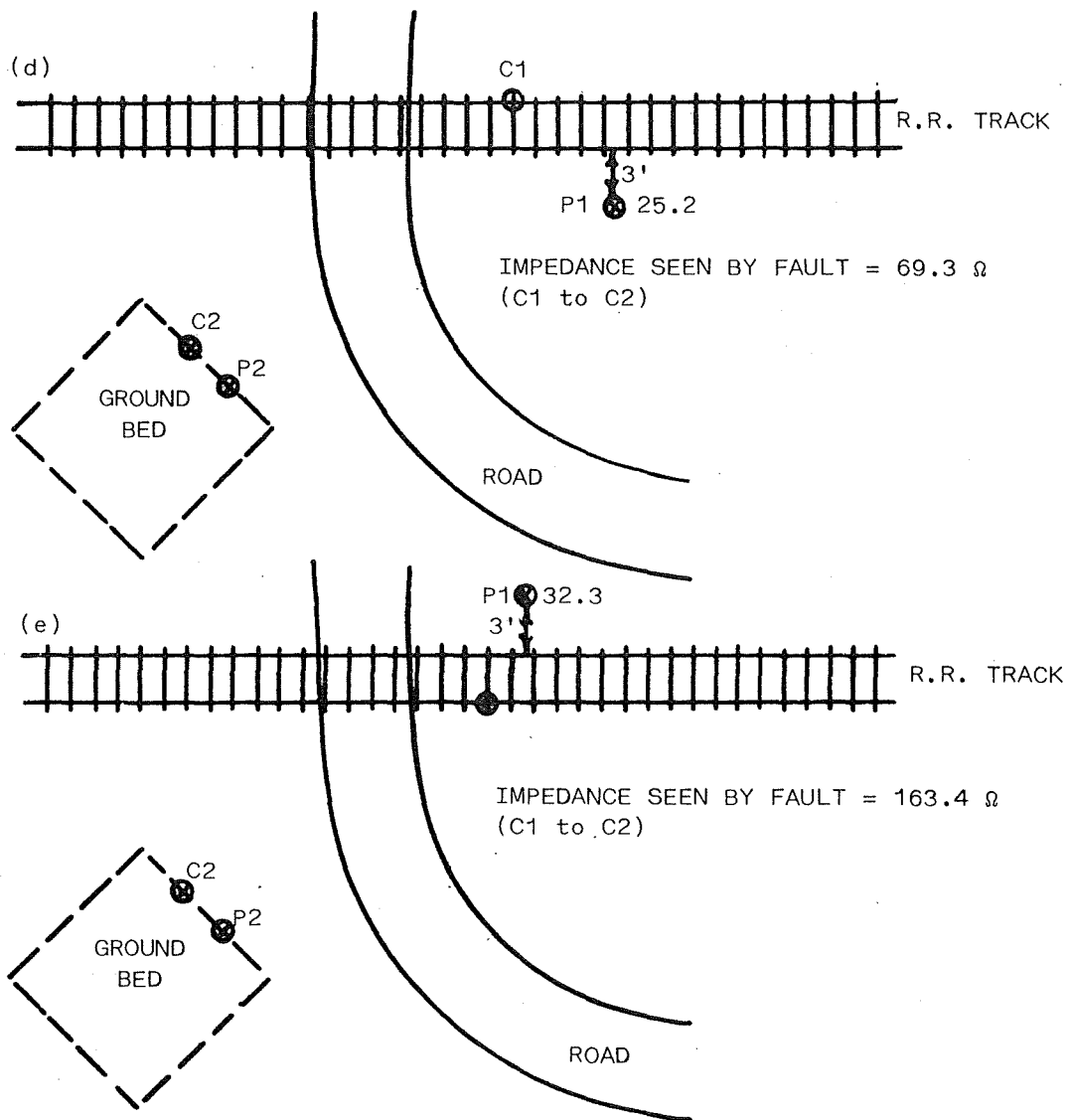

FIGURE 6.5 Touch Potential Measurements at Railroad Track,  
Granite Quarry (continued)

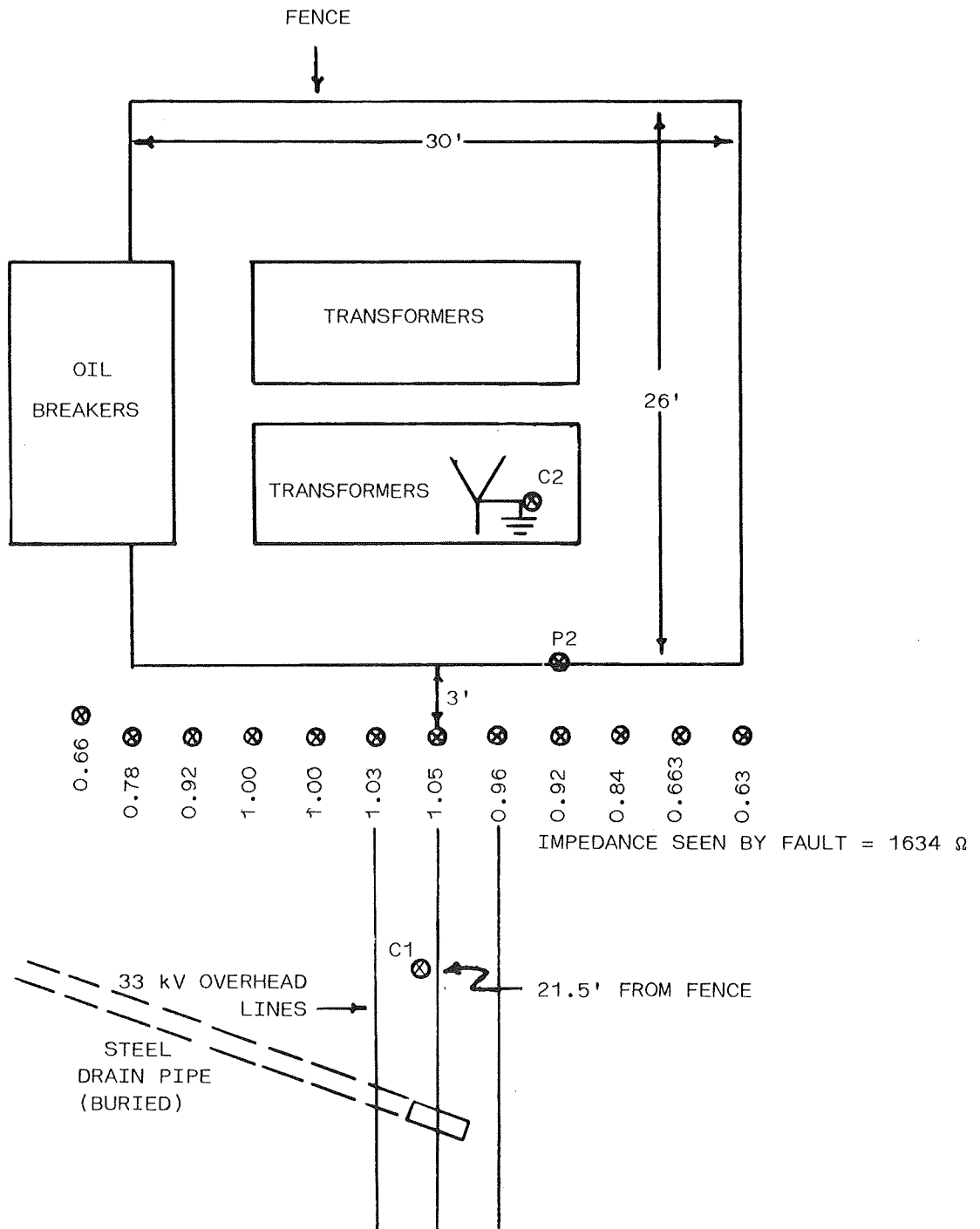

FIGURE 6.6 Touch Potential Measurements at Traprock Quarry, Main Substation; Fault to Ground

Multiplying this fault current by the 1.05 volts of touch potential per ampere of fault current yields 21.2 volts. This is the maximum touch potential that a person would experience while touching the substation fence during a phase-to-earth fault on the 33 kV line.

The second set of measurements was also taken at the main substation. However, this time the return current electrode C1 was connected to a steel drain pipe under the 33 kilovolt lines as shown in Figure 6.7. Approximately two and one-half feet of the drain pipe is exposed under the power lines, and in the absolute worst case one of the conductors could come in contact with it. The pipe is located 32 feet from the fence surrounding the substation. The maximum touch potential was found following the measurement procedure to be 1.08 volts/ampere. It was located along the side of the substation nearest the fault, but near the corner closest to the buried drain pipe. This location was confirmed by series of measurements surrounding the maximum touch potential measurement location. The impedance seen by the fault, measured between points C1 and C2, was found to be only 19.1 ohms. Therefore, for a fault to the steel drain pipe from the 33 kilovolt lines, the fault current that would flow would be 1727.7 amperes. Multiplying the fault current by the maximum touch potential measured above gives a maximum touch potential to the substation fence of 1866 volts. This is a very dangerous potential indeed and is due to the very low resistance of the buried drain pipe.

The third set of touch potential measurements was taken at the crushing plant and is shown in Figure 6.8. The return current electrode was placed at two locations, at a steel well casing and at a metal stake electrode driven into the ground. These locations are C2 and C2-A respectively in the figure. With the return current electrode connected to the well casing, touch potential measurements were made at the door to the breaker building located next to the transformers. The maximum touch potential was measured to be 0.272 volt/ampere for a person touching the door handle. The impedance seen by the fault was measured at 23.1 ohms. For a ground fault from the 4160 volt overhead lines to the well casing, the fault current would be 180 amperes. Therefore, the maximum touch potential to the door handle would be 49 volts. The touch potential was also measured at a set of stairs located near the anticipated fault locations. With the fault electrode located at C2, the touch potential was measured at 1.614 volts/ampere. With a fault impedance of 23.1 ohms, this leads to a touch potential of 290.6 volts. With the fault electrode located at the metal stake C2-A, the touch potential was measured to be 1.818 volts/ampere. The fault impedance to the metal stake was found to be 768 ohms. The touch potential for this case is therefore 9.8 volts. At the crushing plant, a fault to the ground will not produce any dangerous touch potentials. However, a fault to the well casing will produce high touch potentials, and, in the case of the stairs near the fault, dangerously high touch potentials.

High stray currents and input noise were encountered with all the measurements taken at the traprock quarry. It was required to engage the noise filter on the meter in order to obtain accurate touch potential measurements.

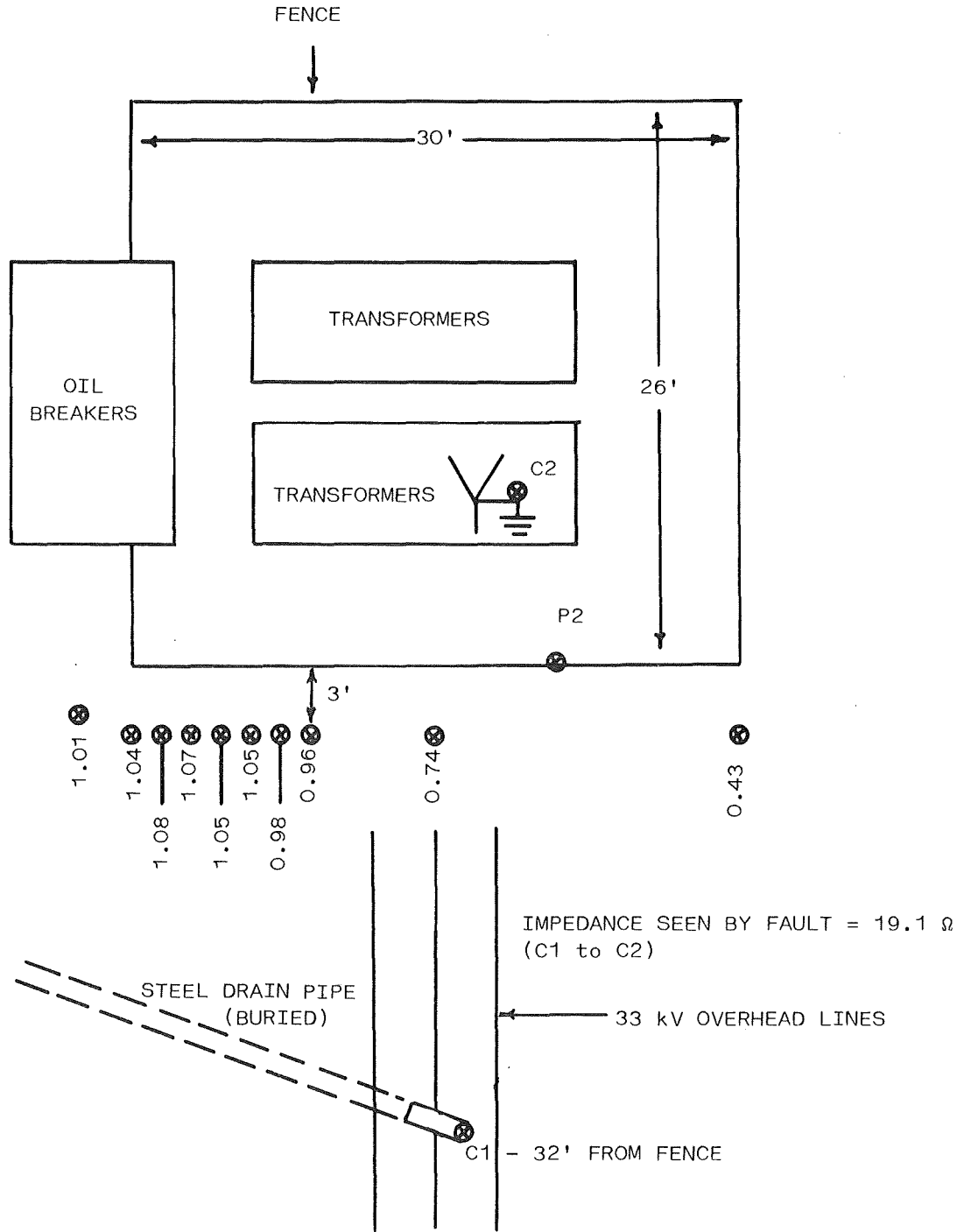

FIGURE 6.7 Touch Potential Measurements at Traprock Quarry, Main Substation; Fault to Metal Drain Pipe

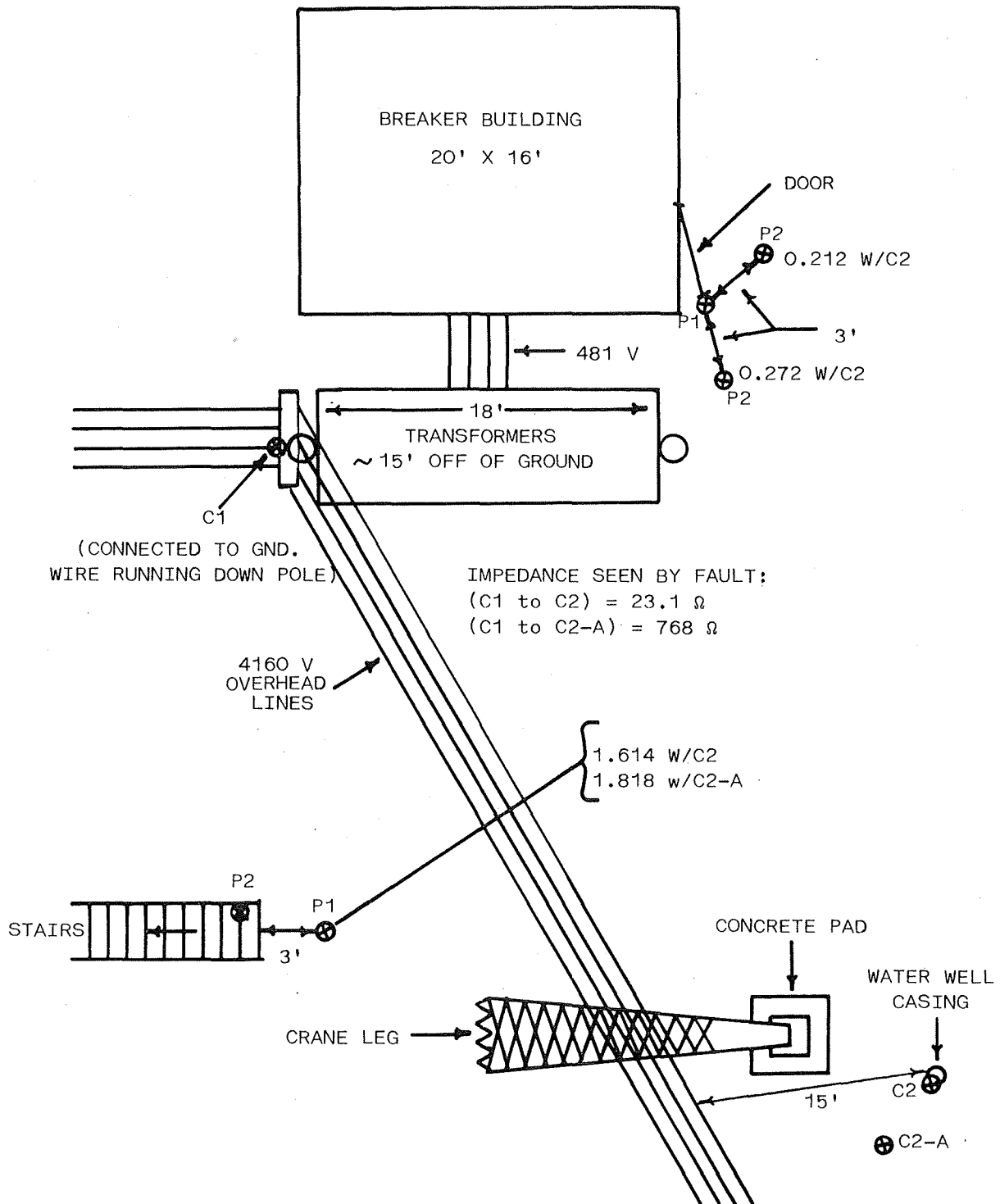

FIGURE 6.8 Touch Potential Measurements at Crushing Plant, Traprock Quarry

### 6.2.3 Difficulty Obtaining Data

The main difficulty encountered during these field tests was very high earth resistivity at the granite quarry and high input noise and stray currents at both locations.

The high earth resistivity was the most difficult problem to overcome. The standard measurement procedure using metal-stake electrodes was impossible to follow because the resistivity meter was unable to circulate enough current through the ground to make a measurement. Fortunately, lower resistance electrodes, in the form of buried steel cable and railroad tracks, were located very near the worst-case fault locations at the granite mine. Using these large metal objects as return electrodes enabled the measurement procedure to be carried out without further modification.

The stray current problem was troublesome but was easier to overcome. At both quarries stray currents large enough to interfere with the resistivity meter were encountered. They were most severe in the vicinity of the substations. In all cases at both quarries, it was necessary to engage the noise filter on the meter to obtain stable touch potential measurements, which increased the time required to take measurements, since the filter slows down the response time of the meter a great deal. Another meter without the capacity to filter out large amounts of input noise would have failed in these field tests.

### 6.3 EFFECTIVENESS OF PROCEDURE

The measurement procedure as outlined in Appendix B was very effective in locating the worst-case touch potentials around mine equipment and facilities. In each case, the worst-case touch potentials were quickly and easily located. Subsequent exhaustive measurements at these sites verified that the location of the highest touch potentials had indeed been found using the measurement procedure.

The only obstacles to the procedure encountered were high earth resistivity and high stray currents. Both of these difficulties were overcome and did not influence the accuracy of the tests.

As long as the power system has a grounded neutral, there is little difficulty interpreting the data. Fault current and touch potential calculations are very straight-forward. However, with an ungrounded delta-connected power system, as encountered at the granite quarry, the interpretation of the data is not as straight-forward. Absolute worst-case touch potential calculations must assume a previous phase-to-ground fault from one of the power conductors.

## CHAPTER 7 - CONCLUSIONS AND RECOMMENDATIONS

The conclusions and recommendations in this chapter pertain to the suitability of the Biddle Digital Earth Tester DET-2\* meter for making the desired measurements, the efficiency and reliability of the procedure developed in locating and assessing potentially dangerous voltage differences, and the further improvement of methods to assess safety.

### 7.1 PERFORMANCE OF THE DET-2\*

As shown in Section 5.2, the DET-2\*, manufactured by the James G. Biddle Company, performed very well in stray current tests and should give reliable readings in the presence of substantial stray current. Our evaluations demonstrated clearly that no other instrument presently available commercially for making measurements of ground field resistance is as immune to stray current. Unless the user is certain that stray current flow is small (no more than 1.0 amperes), the DET-2\* is the instrument of choice.

Using the standard driven-stake electrodes, the DET-2\* failed to provide meaningful measurements under conditions of extremely high earth resistivity encountered in one field test. The investigative team was able to circumvent this problem by using electrodes which were physically much larger than the traditional metal-stake electrodes. This technique is a version of the measurement procedure, recommended when a phase wire could fall on a large metal object in contact with the earth. No alteration of the procedure is believed to be necessary to allow the measurement to be made with the stake electrodes, because any earth resistances sufficiently high to prevent the DET-2\* from making measurements are also high enough to protect workers from shock hazards under the circumstances being investigated.

The DET-2\* is the only device found to be entirely satisfactory for carrying out the designated measurement procedure.

The test instrument is not well suited to potential measurements in underground mines due to surface faults, because the current source and voltmeter are packaged in the same case. Some very expensive geophysical surveying instruments are made in two separate units, but their lack of stray-current immunity, combined with high cost, do not make them competitive with the DET-2\*.

### 7.2 RELIABILITY OF PROCEDURE IN ASSESSING SAFETY

The reliability of the procedure was tested in the field at the WVU ground bed and at two surface non-metal mines. In each case the procedure was followed carefully to determine the greatest hazards

---

\*Reference to specific brands of equipment or trade names in this report is made to facilitate understanding and does not imply endorsement by the Bureau of Mines.

present at the site. Then a systematic and exhaustive search was carried out to locate the points representing the greatest hazard. In each case the exhaustive search and the procedure identified the same points as the most hazardous. When followed closely, the procedure has proven to be completely reliable.

It should be noted that the procedure worked reliably when followed by conscientious individuals who understood and carefully followed each instruction. Before being considered for adoption, the procedure should be tested with less experienced and less thorough individuals to see if ambiguities exist in the instructions or if good intuition appears to be necessary to correctly identify likely hazardous locations and situations.

### 7.3 OVERALL DIFFICULTY IN MAKING MEASUREMENTS

Experience to date indicates that the procedure is very easy to carry out. Time must be allocated to survey thoroughly the areas around substations, power line right-of-way, equipment, and buildings to identify potentially hazardous earth-fault conditions. Once these conditions have been identified, the measurements take but a few minutes. The equipment is lightweight and does not require that long test leads be deployed. The only difficulty experienced so far was caused by the absence of soil around a particular mine, so that electrodes could not be driven into the earth in the traditional manner. Of course, this difficulty would be shared by any method, including the fall-of-potential, which requires driven stakes.

### 7.4 RECOMMENDATIONS FOR ADDITIONAL TESTS OF PROCEDURE

Although the procedure has been demonstrated to effectively identify areas of relatively high touch potential, the accuracy to which the numerical values of these potentials can be determined depends on the certainty to which earth fault currents can be predicted. It is fairly easy to estimate the area of contact of a downed line and to measure the resistance of such a contact for low-voltage conditions. It is known, however, that earth contacts by high-voltage lines often result in ionization of the earth itself, leading to a non-linear relationship between voltage and current flow at the contact point, such that the measured resistance using low voltage may not properly reflect conditions surrounding an actual fault. It is recommended that further study and experimentation be carried out to assess the importance of this non-linear phenomenon on the degree of hazard predicted by the procedure.

As stated in Section 7.2, the procedure located easily areas of greatest touch potential in several tests by conscientious and experienced individuals. It should be tested extensively by a number of groups with experience comparable to those for whom it was designed, such as MSHA inspectors or mine electrical maintenance personnel. Only after it has proven to work well in a great number of situations should it be considered as adequate to base safety decisions upon the results.

## 7.5 RECOMMENDATIONS FOR POSSIBLE REVISIONS OF PROCEDURE

The procedure has been designed to enable the test team to quickly and reliably locate possible hazard areas in all types of mining environments. The requirement of universality led to the adoption of the Biddle DET-2\* as the instrument of choice, since it is lightweight, very resistant to stray current effects, and battery operated. It is also relatively expensive. If extreme portability is not required, then the procedure may be modified to use a portable 60 Hz generator and voltmeter to make the measurements necessary to estimate touch potentials as described in Section 5.4 of this report. Some situations may allow for a realistic staged-fault test, although this type of test is likely to be very dangerous. Utilization of these other techniques for generating test potentials would require modifications to the procedure, mostly to ensure safety of personnel.

Any other revisions of the procedure would depend on the results of the extensive field evaluation discussed in Section 7.4. Although the procedure appears to be unambiguous and reproducible, difficulties experienced in the field may suggest revision of the procedure itself or rewording of the instructions. The need for such revision cannot be predicted at this time.

---

\*Reference to specific brands of equipment or trade names in this report is made to facilitate understanding and does not imply endorsement by the Bureau of Mines.

## LIST OF REFERENCES

1. Dalziel, C.F., Threshold of 60-Cycle Fibrillating Currents, AIEE Transactions, Vol. 79, Pt 3, October 1960, pp. 667-673.
2. Tagg, G.F. Earth Resistances, Pitman Publishing Corporation London (1964), 258 pp.
3. Anonymous, "Getting Down to Earth," Booklet 25T, James G. Biddle Company, Plymouth Meeting, PA, (1970), 48 pp.
4. Anonymous, IEEE Recommended Practice for Grounding of Industrial and Commercial Power Systems, IEEE Standard 142-1982, p. 121.
5. Cooley, W.L., Collins, E., Elrazaz, Z., Kumar, R., McConnell, R., and Jerabek, M., Analysis of Electrical Accident Prevention Countermeasures Final Report, USBM Contract J0113064, West Virginia University, December 1982, BuMines OFR 179-83, 1982, NTIS PB 84-102987, 358 pp.
6. Homce, G.T., An Analysis of Overhead Power-Line Contact Fatalities at Mining Surface Operations, Thesis, Pennsylvania State University, March 1983.
7. Hill, H.W., Jr. Design and Measurement of Driven-Rod Ground Beds, M.S. Thesis, West Virginia University, August 1977.
8. Stevenson, W.D., Jr. Elements of Power Systems Analysis, New York, McGraw-Hill. (1975). pp. 298-342.

APPENDIX A: ELECTRICAL ACCIDENTS RELATED TO GROUNDING SYSTEMS  
IN METAL/NON-METAL MINES

A data base of 405 metal/non-metal electrical accidents (the years 1975, 1976, and 1979)[3] was searched for accidents related to grounding. Four categories of ground-system related accidents are shown.

A-1 Grounding System Intact but Ground-Bed Resistance High

1. Hoist operator wraps steel rope around power line which grounds through frame. (Surface) (Shock, non-disabling)
2. Received shock from stray current from fan cable. (Underground) (Shock, non-disabling)
3. Standing in water, dredge cable sheared by wind. (Dredge) (Shock, fatal)
4. Shocked while getting on shuttle car, apparently caused by leakage from nearby loader cable. (Shock, non-disabling)
5. Attaching ground to electric shovel, ground was energized due to short in lightning arrestor. (Surface) (Shock, minor injury)
6. Attaching ground wire to ground rod, shocked due to short in lightning arrestor. (Surface) (Shock, non-disabling)
7. Two workers electrocuted while checking a pump while electrical storm in the area.

A-2 Grounding System Intact but Ground-Wire Impedance High

1. Desander operator electrocuted when he touched a 2300-V OCB which was inadequately grounded.
2. Worker electrocuted when he touched equipment with a faulty ground connection.
3. Worker was electrocuted when he bridged between a poorly grounded control box and the frame of a crusher.

A-3 Grounding System Not Intact

1. Carrying screen on back which caught on conveyor that was energized due to a short. (Surface) (Shock, non-disabling)
2. Company president electrocuted when he attempted to throw switch to an ungrounded water pump while standing in the water.
3. A worker electrocuted when he touched an ungrounded crusher motor.
4. Electrical leadman electrocuted when he attempted to raise an energized neutral ground wire (sic) over front end loader. Ground connection to wire was broken some time earlier.
5. Company president electrocuted/drowned when he contacted a pump with a phase-to-frame fault for which no ground wire had been provided.
6. Bulldozer operator electrocuted when he stepped directly from his equipment to an electric shovel with a phase-to-frame short and an open ground wire.
7. Laborer electrocuted when he touched the frame of equipment with a 480-V phase-to-frame fault and open ground wire.

8. Foreman electrocuted when he touched a conveyor with a phase-to-frame short circuit and an unconnected ground wire.
9. Wash plant operator electrocuted when he bridged between two ungrounded pieces of equipment with phase-to-frame faults on different phases.
10. Manager electrocuted while standing in water near a trailing cable when it was pulled loose from a connector causing two phase wires and a ground to come in contact with a dredge frame in water.
11. Electrician's helper electrocuted when he contacted improperly grounded junction box which was shorted to 110 V.

#### A-4 Possible Grounding System Inadequacy

1. Worker electrocuted when he touched a pipe at one phase potential while boat was at another phase potential.
2. Worker electrocuted when he touched conveyor frame which was energized by a phase-to-frame fault in the motor.
3. Laborer electrocuted when he grasped the energized frame or case of a submersible water pump on quarry bottom.
4. A worker was electrocuted when the boom of a dragline he was touching contacted a high-voltage line.
5. Touched a junction box and was shocked while repairing a 4170-V pump motor. (Underground) (Shock and electrical burn, minor injury)
6. Shocked by start button on pump. (Surface of Underground mine) (Shock, non-disabling)
7. Shocked by pump switch. (Surface) (Shock, non-disabling)
8. While checking electrical motor, received shock from a knob of limit switch on overhead door. (Surface) (Reaction to electrical, non-disabling)
9. Shutting pipe valve off, pipe was hot. (Shock, non-disabling)
10. Touched pipeline shorted to power conductor. (Surface) (Shock, non-disabling)
11. Shocked while turning water valve. (Surface of underground) (Shock, non-disabling)
12. Loose connection energized grinder frame. (Surface) (Shock, non-disabling)
13. Received shock while cleaning electrical panel. (Surface) (Shock, non-disabling)
14. Gravel chute live due to short in 5-HP motor. (Surface) (Shock, fatal)
15. Shocked while plugging a banana plug into a socket. Grabbed handrail and worsened shock (sic). (Surface) (Electrical burn, non-disabling)
16. While changing a starter, retrieved a piece, causing an arc to the ground which caused starter to come apart (sic). (Surface) (Reaction to electrical, non-disabling)

APPENDIX B - PROCEDURE FOR THE DIRECT MEASUREMENT  
OF TOUCH POTENTIALS\*

CONTENTS OF APPENDIX B

	Page
B.1 INTRODUCTION: CAUTIONS, FEATURES AND LIMITATIONS.....	118
B.2 INSTRUMENT SELECTION.....	119
B.3 OVERVIEW OF METHOD.....	119
B.4 GENERAL GUIDELINES FOR ELECTRODE PLACEMENT.....	121
B.4.1 Machine with a Circular Footprint.....	122
B.4.2 Machine with a Square Footprint.....	123
B.4.2.1 Fault Adjacent to Side of Square.....	123
B.4.2.1 Fault Adjacent to Corner of Square.....	125
B.4.3 Machine with a Rectangular Footprint.....	127
B.4.3.1 Fault Adjacent to Long Side of Rectangle....	127
B.4.3.2 Fault Adjacent to Short Side of Rectangle....	129
B.4.3.3 Fault Adjacent to Corner of Rectangle.....	131
B.4.4 Machine with an Irregular Footprint.....	133
B.5 SPECIFIC RECOMMENDATIONS FOR SELECTED MINE TYPES.....	134
B.6 DETERMINATION OF FAULT CURRENT VALUES.....	135
B.7 INTERPRETATION OF RESULTS.....	136
B.8 MITIGATION OF TOUCH POTENTIAL HAZARDS.....	136

---

\*Developed under USBM Contract No. H0338023 to West Virginia University

## B.1 INTRODUCTION: CAUTIONS, FEATURES AND LIMITATIONS

Personnel making electrical measurements on power systems are ALWAYS subject to some risk of electrical shock. ANY METAL OBJECT OR WIRE CONNECTED TO A POWER SYSTEM SHOULD BE ASSUMED TO BE LETHAL UNTIL IT HAS BEEN TESTED FOR VOLTAGE. The grounding system is NOT an exception to this rule. People HAVE been shocked by ground beds, wires, etc.

Neither the ground-bed resistance method nor the technique described here tests the ability of the grounding conductors to carry the high currents of a phase-to-ground fault. Additional physical inspections or high-current tests should be performed to verify that the grounding system can carry these currents. The magnitude of possible fault currents can be found from the tests described in the last section of this procedure.

- CAUTIONS:
1. THESE METHODS VERIFY THE CONTINUITY, BUT NOT THE AMPACITY OF A GROUNDING SYSTEM.
  2. GROUND BEDS MAY BE SHOCK HAZARDS; CHECK FOR VOLTAGE BETWEEN THE GROUND BED AND A STAKE DRIVEN IN THE EARTH THREE FEET FROM THE BED BEFORE PROCEEDING WITH ANY OTHER MEASUREMENTS.

The degree of safety of a grounding system is usually assessed by a measurement of its ground-bed resistance. An alternative technique of directly measuring shock potentials is presented here. Each technique has its merits. The following guidelines should help determine which is more suitable for a particular mining application.

Touch-potential measurement is recommended when:

- (1) It is physically impossible to disconnect the ground bed.
- (2) The power system cannot be shut down without severe economic penalties.
- (3) Ground faults could reasonably be expected to occur near the ground bed or near equipment grounded by the bed.
- (4) The 'footprint' of grounded equipment is comparable to the size of the ground bed. ('Footprint' here is defined as the outline of the part of the machine in contact with the earth.)
- (5) The grounding system is not well documented and mostly hidden from view.

Ground-bed resistance measurement is recommended when:

- (1) The ground bed is relatively small and conveniently disconnected.
- (2) The quantity or type of equipment to be grounded to the bed changes frequently.
- (3) Equipment connected to the bed changes location significantly between measurements.
- (4) Ground faults are very unlikely to occur near the ground bed or grounded equipment.

If a particular power system is better characterized by the first list above than by the latter one, then the procedure explained here should be applicable.

## B.2 INSTRUMENT SELECTION

It is recommended that a commercial meter built for making ground-bed resistance measurements be used for the touch potential measurement. Any four-terminal meter built for this purpose will be suitable provided that (1) it uses a measurement frequency less than 500 Hz; (2) it produces an open-circuit voltage (between the current terminals) of less than 100 volts; and (3) it works reliably with up to 10 amperes of stray ac or dc current. The first condition assures that the measurement will be relevant to the power-frequency operation of the power system; the second makes sure that the instrument itself will not be a source of electrical shocks; and the last condition insures good measurements in the electrically hostile mining environment.

## B.3 OVERVIEW OF METHOD

Figure B.1 shows the basic schematic of the method. Essentially, a low-level fault (typically 10-20 mA) is staged using the internal current source of the test instrument. Touch potential due to this fault is measured by the voltage detector of the same unit. The instrument meter displays touch potential in volts per ampere of fault current. This number must be multiplied by the largest anticipated ground-fault current to obtain the worst-case touch potential. For example, if the instrument indicated 0.100, on a system where the maximum ground-fault current was expected to be 250 amperes, the maximum touch potential would be 25 volts.

The instrument connections are much like those of the fall-of-potential measurement; personnel familiar with this technique should have little difficulty with measuring touch potentials. One current connection and one voltage connection are made to the ground bed (or grounded equipment) under test, and the second current and voltage connections are made to test electrodes away from the bed (or grounded equipment).

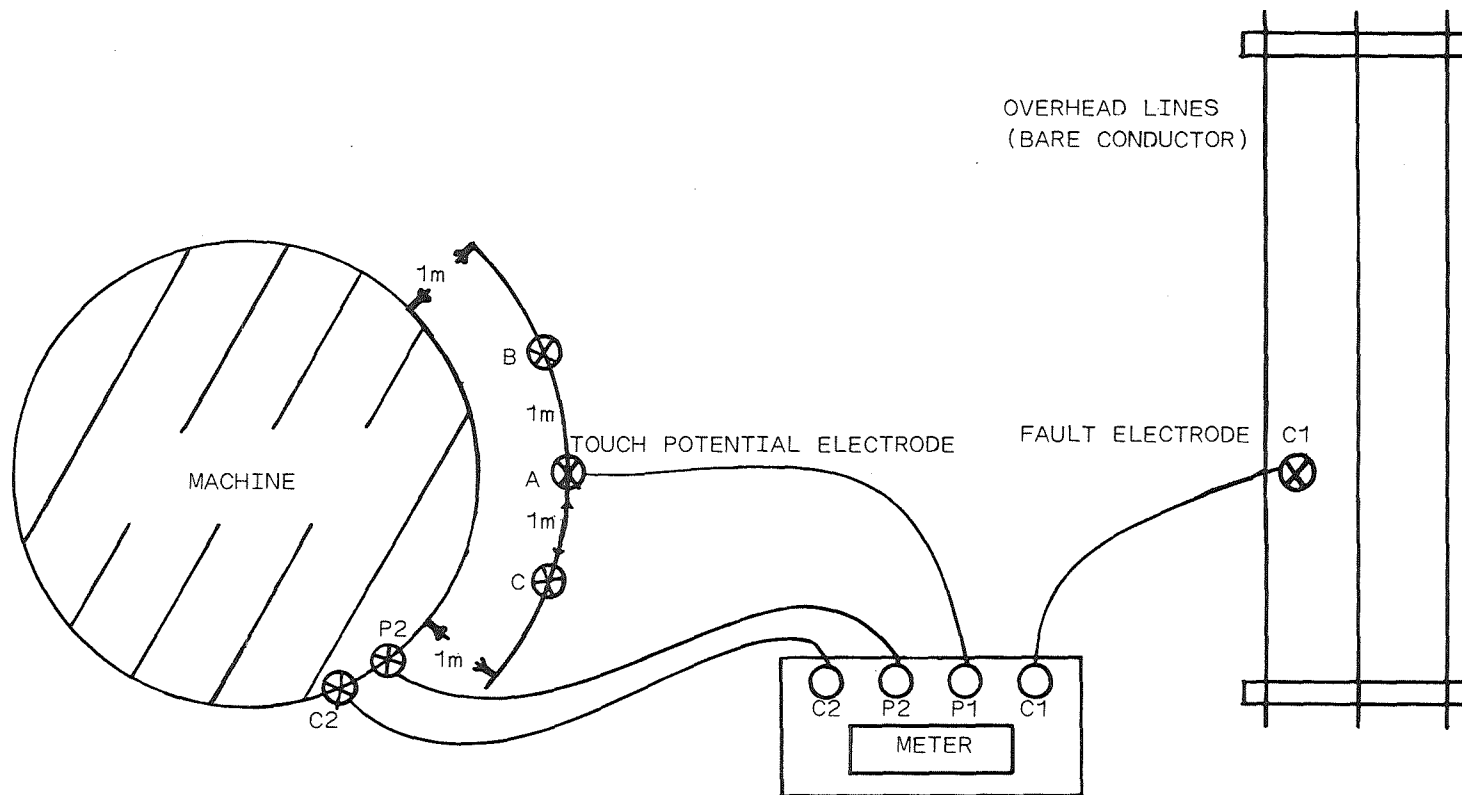

FIGURE B.1 Measuring Touch Potential at a Machine with a Circular Footprint

Differences between the fall-of-potential method and the touch-potential method lie in the locations of these last two electrodes. In the fall-of-potential method, the current electrode is located as far as possible from the ground bed, and the potential electrode is placed at various locations on a line between the ground bed with the current electrode. In the touch-potential measurement, the potential electrode is placed three feet from the ground bed, and the current electrode is located where a ground fault may occur.

#### B.4 GENERAL GUIDELINES FOR ELECTRODE PLACEMENT

As explained above, one current connection is always made to the ground bed. This connection is either made directly, if the test is performed near the bed, or indirectly, if the measurement is done at a piece of grounded equipment. The indirect connection is accomplished by attaching the test lead to the metal frame of the grounded equipment; this establishes electrical continuity to the ground bed through the ground wire.

One voltage connection is also made to the ground bed, indirectly or directly, (as above). It is important that this be a separate wire from the meter to the bed or to the grounded equipment, NOT a jumper between the two meter terminals. A separate clamp should be provided for each connection.

The second current connection should be made to a test stake driven into the ground, at the closest point to the ground bed OR any grounded equipment where a bare phase conductor could come into contact with the earth. If overhead lines pass close to remote grounded equipment, as well as close to the substation where the ground bed is built, the procedure should be performed in both places, even if the distance from the remote-grounded equipment to the overhead line is larger than the distance from the ground bed to the nearest phase-conductor grounding point. NOTE: In some instances, the overhead line passing by remote grounded equipment may be a high-voltage transmission or subtransmission line. A ground fault on one of these high-voltage lines may produce shock hazards which cannot be eliminated even by well-engineered ground beds. This procedure will nonetheless help quantify these hazards.

The second potential connection is also made to a test stake or electrode. Placement of this test electrode is the most difficult part of the measurement procedure. It must be placed three feet from grounded equipment at the point which will produce the maximum instrument reading (the maximum voltage for a given fault current). This location is not always obvious, but time spent checking different locations the first time the measurement procedure is conducted at a given mine site should not have to be repeated during subsequent tests. The paragraphs below list some general guidelines; the following section has some

specific suggestions for different mine types. However, these guidelines and suggestions are no substitute for experience. Any incidence at a mining property of metal objects being 'live' should be investigated using this procedure, by placing the potential connection at that site.

#### B.4.1 Machine with a Circular Footprint

When the touch potential is to be measured near a ground bed or a grounded machine which has a circular footprint, the potential electrode should be placed as close as possible to the current electrode (while maintaining the 3-foot spacing from the edge of the equipment). The most common example of this would be a dragline. Note that the 3-foot spacing should be measured along the ground from the outermost point on the dragline which a person could be expected to touch, NOT from the edge of the tub. The specific steps to be carried out are listed below.

1. Connect one potential lead (P2) and one current lead (C2) of the resistivity meter directly to the machine or object to be tested, as shown in Figure B.1.
2. Locate the fault current electrode (C1) at the point closest to the machine where a bare phase conductor is likely to come in contact with the earth.
3. Locate the touch potential electrode (P1) three feet from the furthest projection on the machine that a person can touch from the ground and directly between the machine and the fault electrode (position A). Record the instrument reading.
4. Relocate the touch potential electrode (P1) three feet to either side of position A (positions B and C), and record the instrument readings there. If the readings at B and C are less than at A, then A is the location of maximum touch potential.
5. If either B or C has a higher reading than A, then take an additional reading one meter from the electrode with the higher reading, on the side of the electrode opposite location A.
6. If the reading at this fourth location is less than at location B or C (depending on which was higher than A), then B or C (again, depending on which was higher than A) is the location of the maximum touch potential.
7. If the reading at this fourth location is greater still, then a fifth reading one meter beyond the fourth is required. Continue this measurement pattern until a maximum reading is obtained. The location of the maximum reading is the location where the maximum touch potential will occur.

8. Measure the two terminal resistance between the fault electrode (C1) and the machine. Leave C2 connect P1 to C1 with a jumper. Record the reading.

9. Calculate the fault current that will circulate between the fault and the machine. The fault current is equal to the voltage of the phase conductor with respect to earth divided by the resistance between the fault and the machine. For example, if the (line-to-line) voltage is 7200 V, corresponding to a line-to-neutral voltage of 4160 V, and the measured resistance is 1230 ohms, then the fault current is  $4160/1230 = 3.38$  A.

10. The maximum touch potential that a person will experience is equal to the fault current multiplied by the maximum instrument reading obtained in steps three through seven.

#### B.4.2 Machine with a Square Footprint

If the touch potential is to be measured near an object with a square footprint, the potential electrode should be placed in at least two different locations. First, it should be positioned as above, closest to the current electrode but still three feet from the edge of the object. Next, the potential electrode P1 should be placed three feet diagonally off the corner closest to the current electrode C1. If these first two potential-electrode positions are more than three feet apart, then the touch potential should be measured in a third position: halfway between the first two locations. If this third position yields the highest instrument reading, then additional positions in the vicinity of this third location should be probed until the maximum is found.

B.4.2.1 Fault Adjacent to Side of Square--If the likely fault location is off the side of the square, the steps outlined below are appropriate.

1. Connect one potential lead (P2) and one current lead (C2) of the resistivity meter directly to the machine or object to be tested, as shown in Figure B.2.
2. Locate the fault current electrode (C1) at the point closest to the machine where a bare phase conductor is likely to come in contact with the earth.
3. Several locations for touch potential measurements need to be investigated. Place the touch potential electrode (P1) at these locations:
  - A. One meter from from the machine directly between the machine and the fault electrode (point A).
  - B. One meter from the machine at the center of the side closest to the fault electrode (point B).

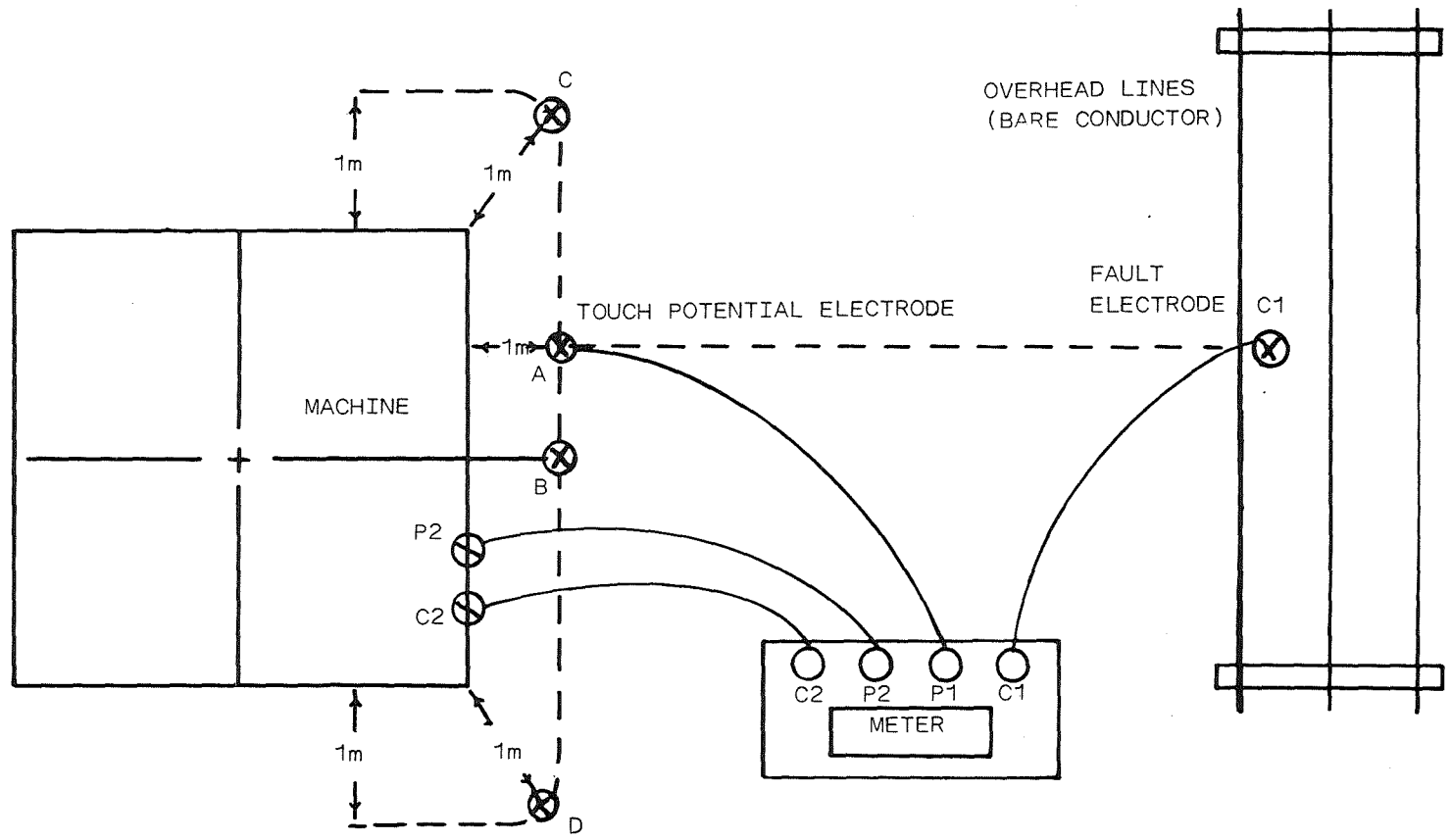

FIGURE B.2 Measuring Touch Potential at a Machine with a Square Footprint, Fault Nearest One Side

- C. One meter from the machine at the two corners closest to the fault electrode (points C and D).

Make a measurement at each of these locations and find the location which gives the maximum reading.

4. Take additional measurements one meter on either side of the maximum reading found in step 3. If these lateral measurements are less than the central measurement, then the central location is where the maximum touch potential will occur.

5. If either of the lateral readings is higher than the central reading, then another measurement needs to be taken one meter beyond the higher lateral reading. Continue this measurement pattern until a maximum reading is found.

6. Measure the two-terminal resistance between the fault electrode (C1) and the machine. Leave C2 and P2 connected to the machine and connect P1 to C1. Record the reading.

7. Calculate the fault current that will circulate between the fault and the machine. The fault current is equal to the voltage of the phase conductor divided by the resistance between the fault and the machine.

8. The maximum touch potential that a person will experience is equal to the fault current multiplied by the maximum instrument reading obtained in steps three through five.

**B.4.2.2 - Fault Adjacent to Corner of Square**--If the likely fault location is off a corner of the square, then the procedure shown next is appropriate.

1. Connect one potential lead (P2) and one current lead (C2) of the resistivity meter directly to the machine or object to be tested, as shown in Figure B.3.

2. Locate the fault current electrode (C1) at the point closest to the machine where a bare phase conductor is likely to come in contact with the earth.

3. Locate the touch potential electrode (P1) at these points near the machine:

- A. One meter from the corner nearest the fault electrode (point A).

- B. One meter from the midpoints of the two sides nearest the fault electrode (points B and C).

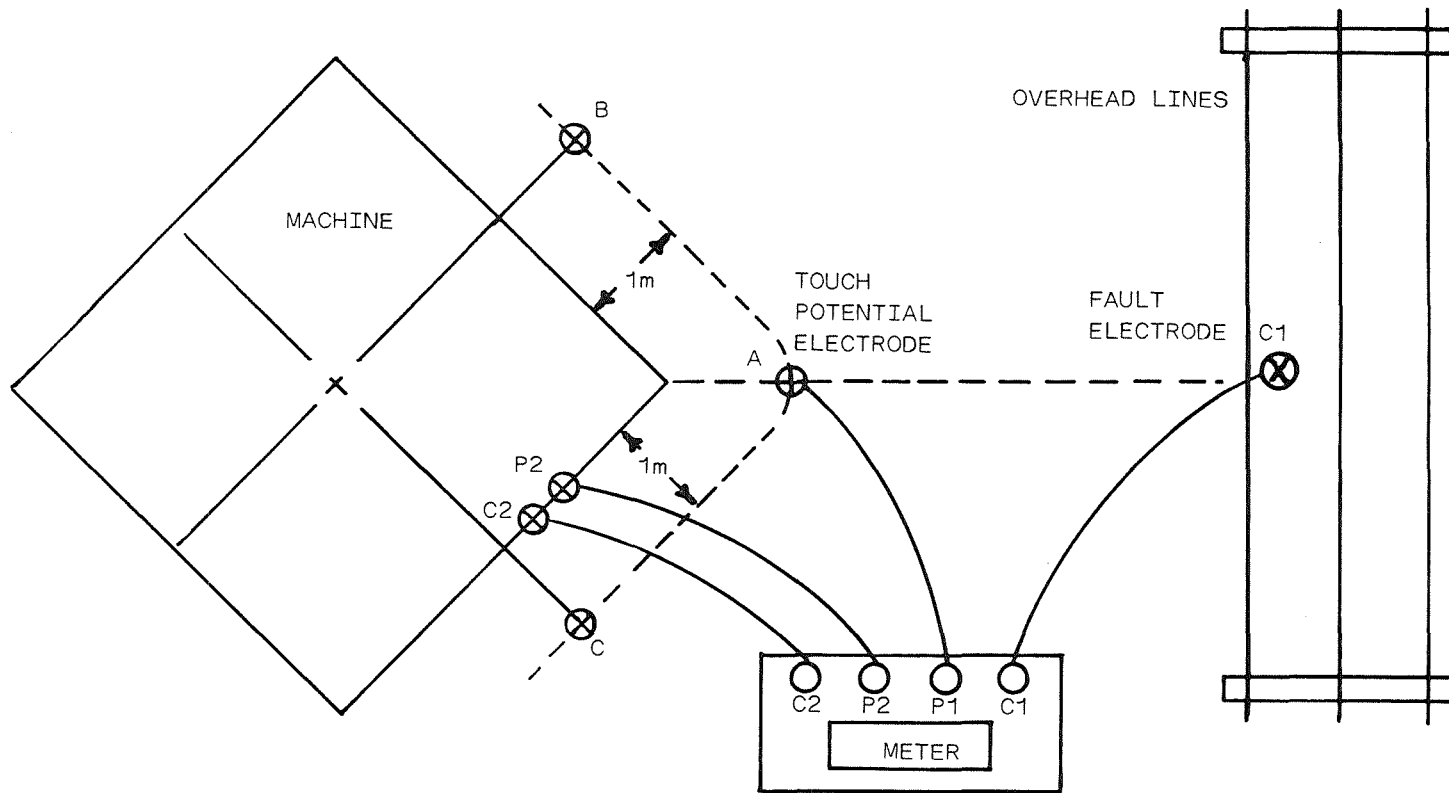

FIGURE B.3 Measuring Touch Potential at a Machine with a Square Footprint, Fault Nearest One Corner

Make measurements at these locations and find the location which gives the maximum reading.

4. Take additional measurements one meter to either side of the maximum reading found in step three. If these lateral measurements are less than the central measurement, then the central location is where the maximum touch potential will occur.
5. If one of the lateral readings is higher than the central reading, then another measurement needs to be taken one meter beyond the higher lateral reading. Continue this measurement pattern until a maximum reading is found.
6. Measure the two-terminal resistance between the fault electrode (C1) and the machine. Leave C2 and P2 connected to the machine and connect P1 to C1. Record the reading.
7. Calculate the fault current that will circulate between the fault and the machine. The fault current is equal to the voltage of the phase conductor divided by the resistance between the fault and the machine.
8. The maximum touch potential that a person will experience is equal to the fault current multiplied by the maximum instrument reading obtained in steps three through five.

#### B.4.3 - Machine With a Rectangular Footprint

If the object has a rectangular footprint, two more potential-electrode positions should be added: three feet off the middle of a short side of the object and three feet off the long side of the object. The short side and the long side chosen should be the closer ones to the current electrode. As above, intermediate positions between these initial positions should be tried until the maximum instrument reading is obtained.

B.4.3.1 - Fault Adjacent to Long Side of Rectangle--If the likely fault location is off the long side of the rectangle, follow the steps below.

1. Connect one potential lead (P2) and one current lead (C2) of the resistivity meter directly to the machine or object to be tested, as shown in Figure B.4.
2. Locate the fault current electrode (C1) at the point closest to the machine where a bare phase conductor is likely to come in contact with the earth.
3. Several locations for touch potential measurements need to be investigated. Place the touch potential electrode (P1) at these locations:

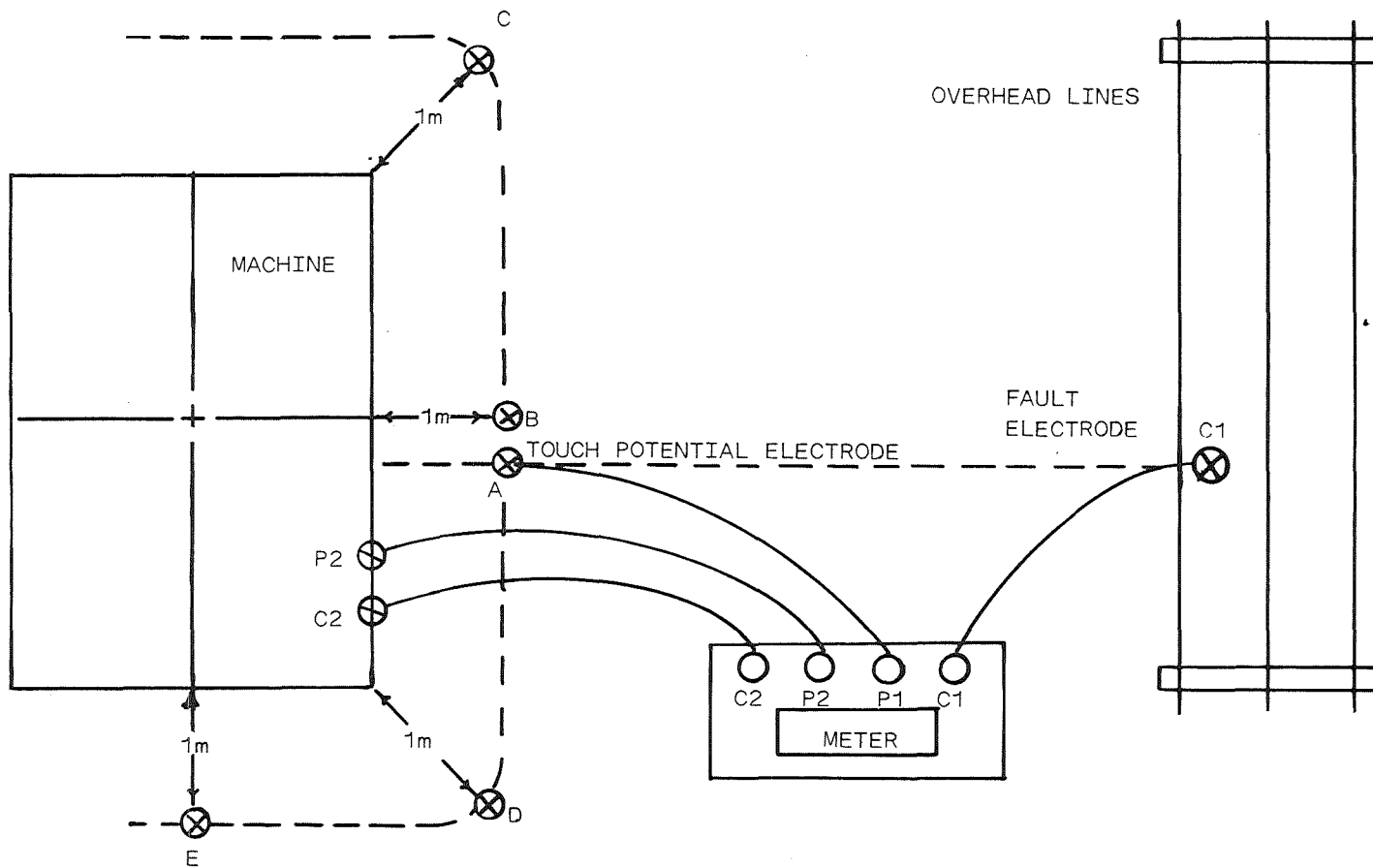

FIGURE B.4 Measuring Touch Potential at a Machine with a Rectangular Footprint, Fault Nearest a Long Side

- A. One meter from the machine directly between the machine and the fault electrode (point A).
- B. One meter from the machine at the center of the side closest to the fault electrode (point B).
- C. One meter from the machine at the two corners closest to the fault electrode (points C and D).
- D. One meter from the machine at the center of the short side closest to the fault electrode (point E).

Make a measurement at each of these locations and find the location which gives the maximum reading.

- 4. Take additional measurements one meter on either side of the maximum reading found in step 3. If these lateral measurements are less than the central measurement, then the central location is where the maximum touch potential will occur.
- 5. If either of the lateral readings is higher than the central reading, then another measurement needs to be taken one meter beyond the higher lateral reading. Continue this measurement pattern until a maximum reading is found.
- 6. Measure the two-terminal resistance between the fault electrode (C1) and the machine. Leave C2 and P2 connected to the machine and connect P1 to C1. Record the reading.
- 7. Calculate the fault current that will circulate between the fault and the machine. The fault current is equal to the voltage of the phase conductor divided by the resistance between the fault and the machine.
- 8. The maximum touch potential that a person will experience is equal to the fault current multiplied by the maximum instrument reading obtained in steps three through five.

B.4.3.2. - Fault Adjacent to Short Side of Rectangle--If the likely fault location is off the short side of the rectangle, the steps outlined below are appropriate.

- 1. Connect one potential lead (P2) and one current lead (C2) of the resistivity meter directly to the machine or object to be tested, as shown in Figure B.5.
- 2. Locate the fault current electrode (C1) at the point closest to the machine where a bare phase conductor is likely to come in contact with the earth.

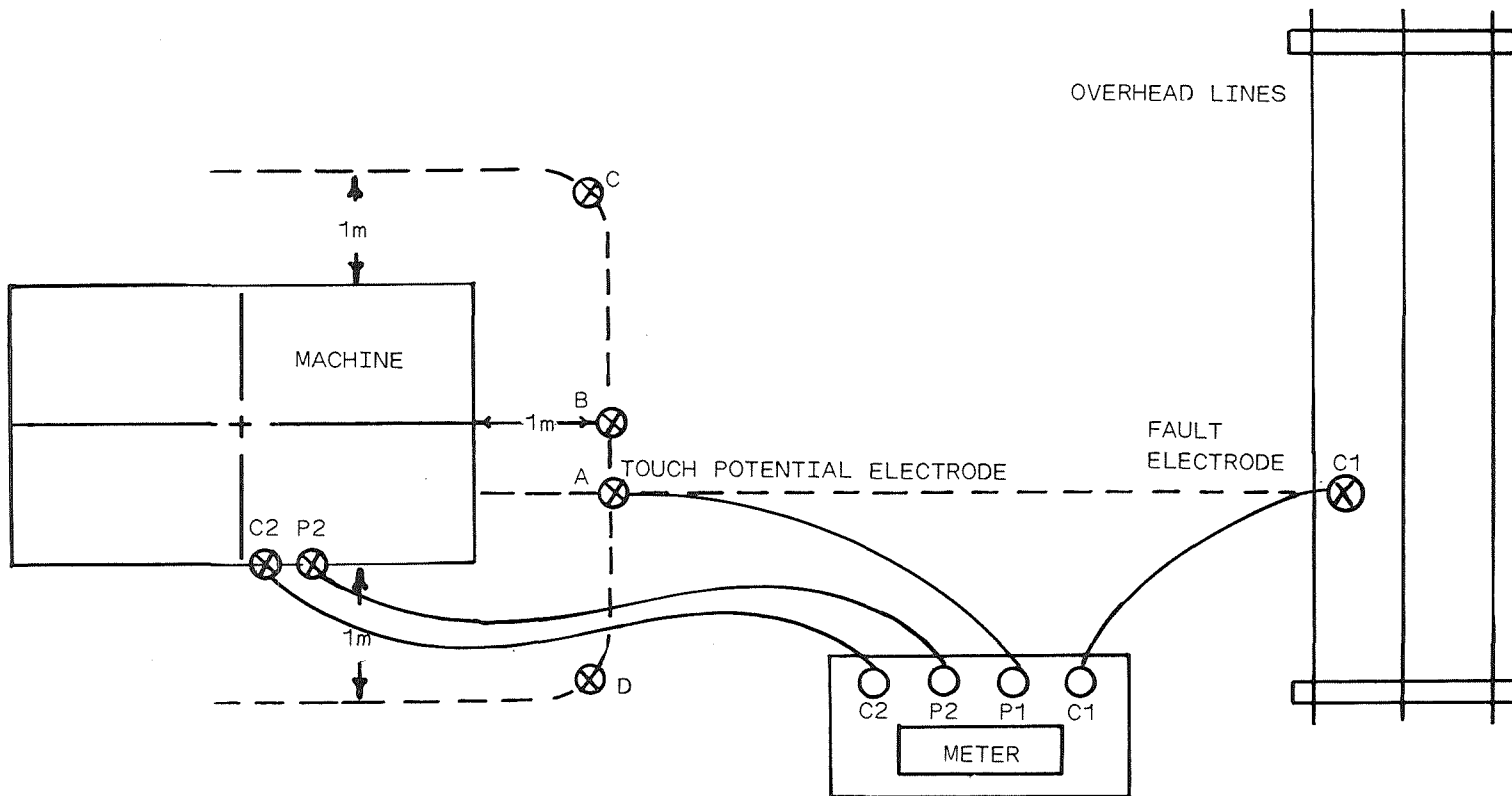

FIGURE B.5 Measuring Touch Potential at a Machine with a Rectangular Footprint, Fault Nearest a Short Side

3. Several locations for touch potential measurements need to be investigated. Place the touch potential electrode (P1) at these locations.

- A. One meter from the machine directly between the machine and the fault electrode.
- B. One meter from the machine at the center of the side closest to fault electrode (point B).
- C. One meter from the machine at the two corners closest to the fault electrode (points C and D).

Make a measurement at each of these locations and find the location which gives the maximum reading.

4. Take additional measurements one meter on either side of the maximum reading found in step 3. If these lateral measurements are less than the central measurement, then the central location is where the maximum touch potential will occur.

5. If either of the lateral readings is higher than the central reading, then another measurement needs to be taken one meter beyond the higher lateral reading. Continue this measurement pattern until a maximum reading is found.

6. Measure the two-terminal resistance between the fault electrode (C1) and the machine. Leave C2 and P2 connected to the machine and connect P1 to C1. Record the reading.

7. Calculate the fault current that will circulate between the fault and the machine. The fault current is equal to the voltage of the phase conductor divided by the resistance between the fault and the machine.

8. The maximum touch potential that a person will experience is equal to the fault current multiplied by the maximum instrument reading obtained in steps three through five.

B.4.3.3 - Fault Adjacent to Corner of Rectangle--If the likely fault location is off the corner of the rectangle, the steps outlined below are appropriate.

- 1. Connect one potential lead (P2) and one current lead (C2) of the resistivity meter directly to the machine or object to be tested, as shown in Figure B.6.
- 2. Locate the fault current electrode (C1) at the point closest to the machine where a bare phase conductor is likely to come in contact with the earth.
- 3. Locate the touch potential electrode (P1) at these points near

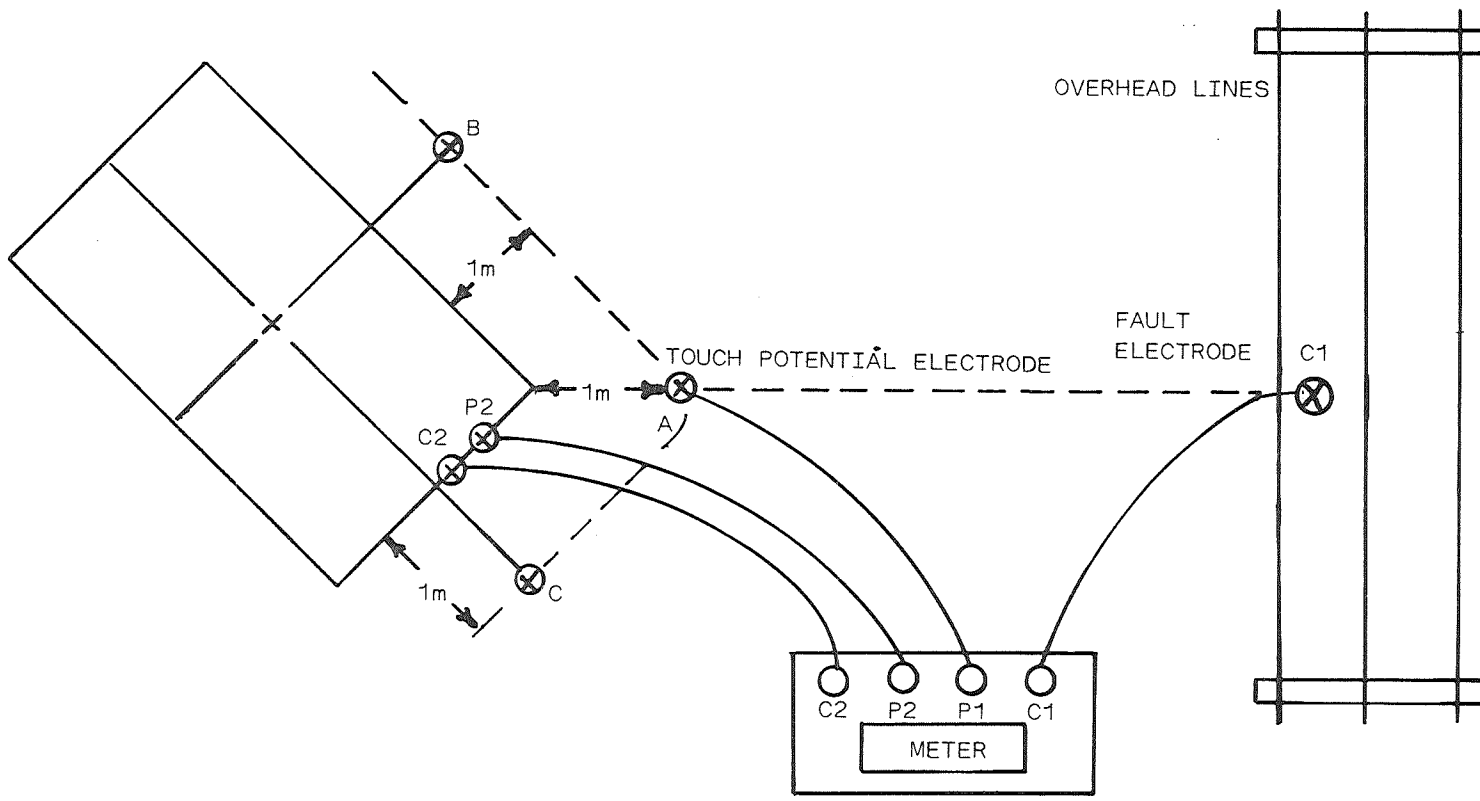

FIGURE B.6 Measuring Touch Potential at a Machine with a Rectangular Footprint, Fault Nearest One Corner

3. Locate the touch potential electrode (P1) at these points near the machine:

A. One meter from the corner nearest the fault electrode (point A).

B. One meter from the midpoints of the two sides nearest the fault electrode (points B and C).

Make measurements at these locations and find the location which gives the maximum reading.

4. Take additional measurements one meter to either side of the maximum reading found in step three. If these lateral measurements are less than the central measurement, then the central location is where the maximum touch potential will occur.

5. If one of the lateral readings is higher than the central reading, then another measurement needs to be taken one meter beyond the higher lateral reading. Continue this measurement pattern until maximum reading is found.

6. Measure the two-terminal resistance between the fault electrode (C1) and the machine. Leave C2 and P2 connected to the machine and connect P1 to C1. Record the reading.

7. Calculate the fault current that will circulate between the fault and the machine. The fault current is equal to the voltage of the phase conductor divided by the resistance between the fault and the machine.

8. The maximum touch potential that a person will experience is equal to the fault current multiplied by the maximum instrument reading obtained in steps three through five.

#### B.4.4 - Machine with an Irregular Footprint

Irregularly-shaped objects provide the greatest challenge. If the object has a shape which can be approximated by those discussed above, then the recommendations for that shape can be followed. Special attention should be given to narrow extensions of the object footprint, such as outriggers on drills, dragline buckets, and conveyor belts. Measurements should be made off the ends of these extensions, beginning with those which are closest to the current electrode C1. It may be necessary to consider several current-electrode positions if the object is large and ground faults could occur at different points near the object. The potential electrode should be placed three feet off the end of any extension that a person can touch while standing on earth, regardless of whether or not the extension is in contact with the earth. The specific steps to be carried out are listed below.

1. Connect one potential lead (P2) and one current lead (C2) of the resistivity meter directly to the machine or object to be tested.
2. Locate the fault current electrode (C1) at the point closest to the machine where a bare phase conductor is likely to come in contact with the earth.
3. Locate the touch potential electrode (P1) at these points near the machine:
  - A. One meter from the machine directly between the machine and the fault electrode (point A).
  - B. One meter from the machine at all narrow projections or extensions.
  - C. One meter from the machine at the center of narrow sides of the machine nearest the fault electrode. Make measurements at these locations and find the location which gives the maximum reading.
4. Take additional measurements one meter to either side of the maximum reading found in step three. If these lateral measurements are less than the central measurement, then the central location is where the maximum touch potential will occur.
5. If one of the lateral readings is higher than the central reading, then another measurement needs to be taken one meter beyond the higher lateral reading. Continue this measurement pattern until a maximum reading is found.
6. Measure the two-terminal resistance between the fault electrode (C1) and the machine. Leave C2 and P2 connected to the machine and connect P1 to C1. Record the reading.
7. Calculate the fault current that will circulate between the fault and the machine. The fault current is equal to the voltage of the phase conductor divided by the resistance between the fault and the machine.
8. The maximum touch potential that a person will experience is equal to the fault current multiplied by the maximum instrument reading obtained in steps three through five.

#### B.5 SPECIFIC RECOMMENDATIONS FOR SELECTED MINE TYPES

Separate Ground Beds. An additional test should be performed at mines which follow the practice (required in coal mines) of having two separate ground beds. The current electrode should be placed to simulate a ground fault as close as conceivable to the station ground, and the touch potentials measured at the safety ground. The potential electrode should be positioned as above, close to the current electrode, but three feet from the bed. This test will evaluate the

effectiveness of ground-bed separation. Ground faults near the safety ground bed should be probed as outlined in Section B.4, treating the bed as a 'machine' with the same footprint as the bed.

**Dredging Operations.** Although a dredge is surrounded by water, it is treated like any other machine in the touch-potential measurement (although the potential probe has to be located in the water). Special attention should be given to the side of the dredge where personnel get on or off, but highest touch potentials will usually be encountered on the side of the dredge closest to the shore power feed. The current probe should be positioned for the closest ground fault to the dredge. This may be at a cable coupler close to the dredge, in addition to the usual overhead line locations.

**Open-pit Mines.** For mines with ring feeds, care should be taken to ensure that the closest possible ground fault be used when checking for touch potentials on pit equipment. An overhead line does not have to feed a particular machine to cause a shock hazard at the machine when it is downed.

**Underground Mines.** It is not practical to check touch potentials on underground machinery due to a surface ground fault. Measurements will have to be made at the ground bed on the surface.

## B.6 DETERMINATION OF FAULT-CURRENT VALUES

The instrument readings obtained from the procedures previously outlined determine maximum values of mutual resistances, that is, touch potentials per ampere of fault current. Values of maximum ground-fault current must be found to convert these instrument readings into touch potentials. There are three principal sources of these maximum currents: (1) engineering estimates from line impedances and assumed fault impedance; (2) staged-fault tests, and (3) the experimental approach explained below. Of the three methods, the first is the most approximate, as it requires assuming a value for the ground-fault impedance. Because this impedance is a critical parameter in the calculation, large errors can be introduced.

Staged-fault tests produce much more reliable numbers, but the potential danger to personnel and the electrical stress on equipment make this an unattractive alternative. Also, variations in earth resistivity and the length of phase conductor in contact with the earth produce a wide range of fault currents. However, for overhead lines above 15 kV, there is no good alternative.

The experimental approach is to experimentally measure the resistance seen by the faulted phase. Dividing the line-to-neutral voltage by this resistance produces an estimate of the ground-fault current. This approach works if the ground-fault resistance is much larger than the source impedance (usually true) and the line voltage is low enough so that ionization of the earth is not appreciable (usually true for 15 kV or less). Merits of this method are that variations in earth resistivity are taken into account, and that special

situations, such as phase conductors falling on ungrounded metal objects, can be explicitly considered.

Figure B.7 illustrates the procedure. A current is circulated between the system neutral and an electrode corresponding to the downed phase conductor. This electrode may be a length of bare conductor on the ground, representing the phase conductor or may be a metal object which a phase conductor could fall on. (The chosen object should not be connected to the grounding system, as this would not produce substantial ground-fault current; the fault would be line-to-neutral.) The ground fault should be located at the worst-case position of the current electrode, determined above. Note that the grounding resistor, if present, would be correctly included in the ground-fault resistance.

The resistance measured above should be divided into the highest line-to-neutral voltage expected on a continuous basis. Because the measured resistance is a low estimate of the fault impedance, the fault current calculated will be a conservative (high) estimate of the maximum fault current. This estimated current may be unreasonably high if the measured resistance is very low, due to the neglected impedance of the transmission and distribution system.

#### B.7 INTERPRETATION OF RESULTS

The maximum instrument reading obtained previously, multiplied by the maximum ground-fault current, yields the worst-case touch potential. If the maximum fault current was found from the experimental procedure of the last section, the results should be reviewed to verify that the ground-fault resistance was measured at the same location as the current electrode was placed for the original test.

Touch potentials of 100 volts or more are unacceptable. If the tests reveal values close to, but less than, 100 volts the test procedure should be reviewed and additional measurements should be taken to ensure that the worst-case values have indeed been found. Values approaching 100 volts can be lethal in a wet or otherwise low-resistivity area.

#### B.8 MITIGATION OF TOUCH-POTENTIAL HAZARDS

Reduction of touch potentials, or reduction of hazards due to these potentials, cannot be fully treated here. Listed below are some methods of attacking the problem. In general, the hazard is reduced by decreasing the ground-fault current, by decreasing the mutual resistance (voltage per ampere of fault current), or else keeping personnel away from an area of high potentials.

Touch potentials can be reduced by increasing the separation of overhead lines and equipment (or ground beds) from possible ground-fault locations. Moving either the overhead line or the equipment will reduce the hazard. If the high touch potential is

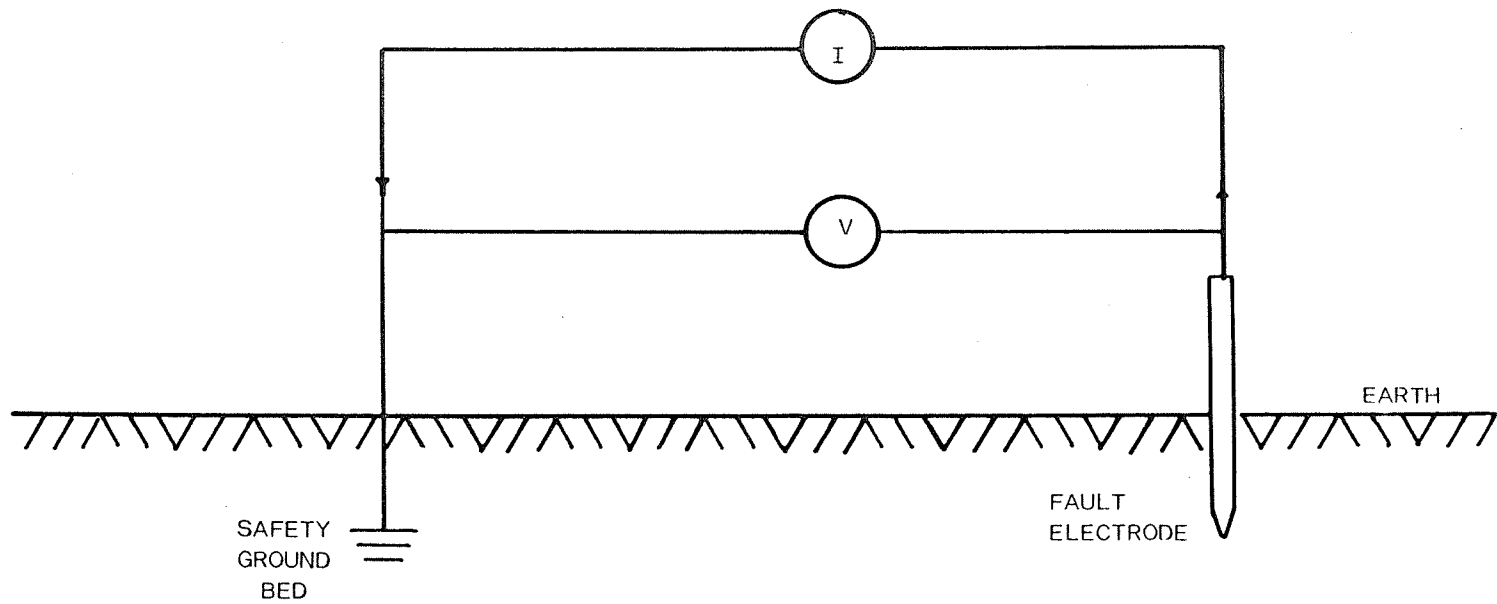

FIGURE B.7 Determination of Expected Fault Current

confined to a small area, such as the dragline bucket near an overhead line, keeping personnel away from the area may be effective. Adding additional rods to narrow sides of ground beds will reduce touch potentials near these sides. Reducing ground-fault current, by moving metal objects out of the right-of-way of distribution lines (to increase the ground-fault impedance), by increasing grounding-resistor value (to increase the resistance in series with the fault) or by placing gravel in low-resistivity areas under lines (to increase ground-fault impedance) will also decrease touch potentials.

If these techniques do not reduce the hazards sufficiently, redesign of the grounding system may be necessary. Separation of grounds may be advantageous; in some cases, the opposite procedure of combining separate ground beds (if permitted) may provide relief.