

# Molded polymer-coated composite bone void filler improves tobramycin controlled release kinetics

Benjamin D. Brooks,<sup>1</sup> Kristofer D. Sinclair,<sup>2</sup> Sherry N. Davidoff,<sup>3</sup> Scott Lawson,<sup>3</sup> Alex G. Williams,<sup>3</sup> Brittany Coats,<sup>4</sup> David W. Grainger,<sup>1,3</sup> Amanda E. Brooks<sup>1,2</sup>

<sup>1</sup>Department of Pharmaceutics and Pharmaceutical Chemistry, University of Utah, Salt Lake City, Utah 84112-5820

<sup>2</sup>Elute Inc., 417 Wakara Way, Suite 3510, Salt Lake City, Utah 84108

<sup>3</sup>Department of Bioengineering, University of Utah, Salt Lake City, Utah 84112-5820

<sup>4</sup>Department of Mechanical Engineering, University of Utah, Salt Lake City, Utah 84112-5820

Received 24 July 2013; revised 2 November 2013; accepted 16 November 2013

Published online 26 December 2013 in Wiley Online Library (wileyonlinelibrary.com). DOI: 10.1002/jbm.b.33089

**Abstract:** Infection remains a significant problem associated with biomedical implants and orthopedic surgeries, especially in revision total joint replacements. Recent advances in antibiotic-releasing bone void fillers (BVF) provide new opportunities to address these types of device-related orthopedic infections that often lead to substantial economic burdens and reduced quality of life. We report improvements made in fabrication and scalability of an antibiotic-releasing polycaprolactone-calcium carbonate/phosphate ceramic composite BVF using a new solvent-free, molten-cast fabrication process. This strategy provides the ability to tailor drug release kinetics from the BVF composite based on modifications of the inorganic substrate and/or the polymeric component, allowing extended tobramycin release at bactericidal concentrations. The mechanical properties of the new BVF composite are comparable to many reported BVFs and validate the relative homogeneity of

fabrication. Most importantly, fabrication quality controls are correlated with favorable drug release kinetics, providing bactericidal activity to 10 weeks *in vitro* when the polycaprolactone component exceeds 98% w/w of the total polymer fraction. Furthermore, in a time kill study, tobramycin-releasing composite fragments inhibited *S. aureus* growth over 48 h at inoculums as high as 10<sup>9</sup> CFU/mL. This customizable antibiotic-releasing BVF polymer-inorganic biomaterial should provide osseointegrative and osteoconductive properties while contributing antimicrobial protection to orthopedic sites requiring the use of bone void fillers. © 2013 Wiley Periodicals, Inc. *J Biomed Mater Res Part B: Appl Biomater*, 102B: 1074–1083, 2014.

**Key Words:** bone void filler, osteomyelitis, tobramycin, controlled release, polycaprolactone, implant infection, joint replacement, revision surgery

**How to cite this article:** Brooks BD, Sinclair KD, Davidoff SN, Lawson S, Williams AG, Coats B, Grainger DW, Brooks AE. 2014. Molded polymer-coated composite bone void filler improves tobramycin controlled release kinetics. *J Biomed Mater Res Part B* 2014;102B:1074–1083.

## INTRODUCTION

As the world population ages, orthopedic surgeries are projected to exceed six million per year by 2030.<sup>1</sup> Chief among these is total joint replacement (TJR) surgeries, including total hip arthroplasty (THA) and total knee arthroplasty (TKA). Concurrent with the rising numbers of primary TJRs, THA revisions are projected to exceed 50,000 annually by 2030, with TKA revision surgeries projected to be nearly 5 times higher.<sup>2</sup> Although infection rates remain consistently low for primary TJR procedures, overall numbers of affected individuals are increasing. Many revision arthroplasty surgeries are attributed to periprosthetic joint infections: infection rates for total joint revision surgeries persist as high as 8–15% despite significant efforts to introduce new bone graft materials, utilize high potency systemic antibiotic treatments, and develop new combination devices.<sup>3,4</sup> Many

of these infections require revision surgeries, adding more than \$50,000 (U.S.) per surgery and exposing the patient to numerous risks and compromised quality of life.<sup>5,6</sup> As global demands for TJR procedures burgeon, so do concerns of infection, particularly those associated with antibiotic resistant pathogens. Therefore, it is necessary to develop and implement new antimicrobial strategies to reduce the costs associated with revision TJR procedures to prevent, what will otherwise become, a considerable economic burden.

A critical component of TJR procedures, whether primary or revision, is bone void fillers (BVs), that support host bone mass for medical device integration. Currently, the demand for bone void fillers is estimated at ~\$1.3 billion of an expanding \$29 billion total orthopedics biomaterial market.<sup>7–9</sup> BVF needs for knee reconstruction will exceed \$600 million by 2030 and close to another

**Correspondence to:** A.E. Brooks (e-mail: amanda.brooks@pharm.utah.edu)

Contract grant sponsors: Elute Inc. (USA), the State of Utah Technology Commercialization and Innovation Program, and the University of Utah Undergraduate Research Program

**TABLE I. Different material compositions of antibiotic-releasing molded polymer-controlled bone graft composites used for this study. Ratios of polymers PCL and PEG were changed as the matrix and poragen, affecting the drug-release kinetics.**

Group	PCL (mg)	PEG (mg)	Synthetic Bone (mg)	Tobramycin (mg)
1	142.5	7.5	350	5.5
2	147	3	350	5.5
3	150	0	350	5.5

\$150 million for THA (estimated from an average 12.7 mL and ~\$1,800 per surgery).<sup>10,11</sup> Current BVF products are classified as medical devices in the United States and fall into several categories: (1) autograft (i.e., intra-operative patient-harvested bone), (2) allograft (i.e., cadaveric-sourced decellularized bone tissue), and<sup>1</sup> synthetic bone fillers (e.g., calcium phosphate (CaP) granules, hybrid calcium carbonate/CaP coralline ceramic bone graft, hydroxyapatites, HAPs).<sup>12,13</sup> Although each of these BVFs recapitulates aspects of the native structure of cancellous bone, the success of the product depends on the ability of the BVF to be highly biocompatible (minimal foreign body response), bioresorbable and osseointegrative (replaced by natural regenerated host bone), and to have minimal cross-contamination (no risk of disease transmission).<sup>12-14</sup> BVFs also are selected based on socio-cultural, religious and physician preference factors, and radio-opacity.

The clinical success of bone void fillers relies on the surgeon's skill in correctly packing the orthopedic defect to facilitate rapid revascularization of the implant site, leading to subsequent osseointegration of the bone void filler and the prevention of disease susceptible sequestra. BVF offers maximum wound packing efficiency and high surface area to provide a cellular environment conducive to bone remodeling and tissue integration.<sup>15</sup> Often, however, the joint replacement surgical site remains minimally vascularized, especially after revision procedures, facilitating osteomyelitis and subsequent osteonecrosis (sequestra).<sup>16</sup>

To address the risk of osteomyelitis at orthopedic surgical sites, highly porous BVFs utilize biodegradable components (e.g., inorganic and polymer phases) to provide drug delivery capability for either treatment or prophylactic prevention of osteomyelitis.<sup>2-6,15,17-20</sup> Previous studies conducted by Brooks et al. have shown that cancellous allogenic bone graft fragments impregnated with various antibiotic-releasing polymer coatings deliver controlled amounts of antibiotics, intended for local delivery to bone graft sites.<sup>7,14</sup> Advantages of such a delivery system include control over local dosing, providing high drug concentrations locally while reducing systemic drug exposure. Such a local targeted approach minimizes the development of antibiotic resistance by maintaining sustained drug amounts sufficient to both prevent and treat microbial infection locally throughout the clinically relevant 6-8 week postsurgical time point (determined by the TJR hardware exchange standard of care for a two-stage revision), eliminating broad-spectrum antibiotic overuse and

poor patient therapy compliance, and avoiding systemic toxicity associated with high antibiotic doses.<sup>14,21,22</sup>

This BVF with adjunct drug delivery capabilities is a combination medical device with multiple advantages over current devices.<sup>23,24</sup> Nonetheless, several disadvantages associated with fabrication of the original BVF drug delivery system,<sup>14,21,25</sup> using allograft fragment dip-coating were limiting to production consistency and ultimately reliable efficacy. First, consistent drug loading on each cancellous fragment during polymer/drug spray or dip-coating was challenging, likely resulting from the high intrinsic variation in allograft crouton surface areas and coating inconsistencies. Second, scalability to high volume of consistently sized and drug-coated allograft bone fragments that administer predictable amounts of drug was challenging and time-consuming, but required to move the concept forward toward clinical use.

To overcome these disadvantages while leveraging the advantages of local, sustained drug delivery through the 6-8 week desired clinical window, a new fabrication process for controlled delivery of antibiotic from a polymer-coated synthetic BVF composite was developed using a customizable solvent-free, molten-casting procedure. Drug loading and subsequent versatility of drug release kinetics were achieved by employing different blending ratios of two known biomedical polymers, polycaprolactone (PCL) and polyethyleneglycol (PEG). *In vitro* antibiotic release profiles were analyzed using Zone of Inhibition studies (ZOI) against *Staphylococcus aureus*, the single most causative organism in osteomyelitis cases.<sup>7</sup> Also, while BVFs are not specifically designed to be load-bearing devices, mechanical properties were assessed by compressive testing. Last, to test the effectiveness of the new implant fabrication process, controls were instituted for the dimensions, mechanical integrity, and shelf life of the implants. This new process resulted in extended release profiles with antibiotic bioactivity observed beyond 8 weeks, comparable mechanical properties, and more reliable metrics for quality control compared to previously reported methods.

## MATERIALS AND METHODS

**Fabrication of Polymer-Coated Inorganic BVF Fragments**  
ProOsteon 500R<sup>TM</sup>, a clinical grade commercial hybrid coralline inorganic bone void filler (Biomet, USA) was morselized using a mortar and pestle. Morselized granules were sieved and particles between 125 and 400  $\mu\text{m}$  were included in all subsequent fabrication steps. Polycaprolactone 10 kD (PCL, Sigma 440752) was mixed with various concentrations of polyethylene glycol 20 kD (Sigma P2263) (see formulations in Table I) and heated at 75°C in a metallic tray until the polymers completely melted to blend (Figure 1). Based on previous work single molecular weights of each polymer were utilized during all experiments.<sup>14,21,22</sup> Morselized ProOsteon granules (~60% w/w, Table I) and tobramycin sulfate (Research Products International T45000-1.0; 10% w/w, Table I) were then well mixed in a metal tray with a metallic spatula into the molten polymer mixture. Importantly, tobramycin was chosen for incorporation as a model antibiotic due to its thermostability and clinical familiarity.<sup>26-28</sup> Subsequently, the polymer-coraline substrate-drug composite molten

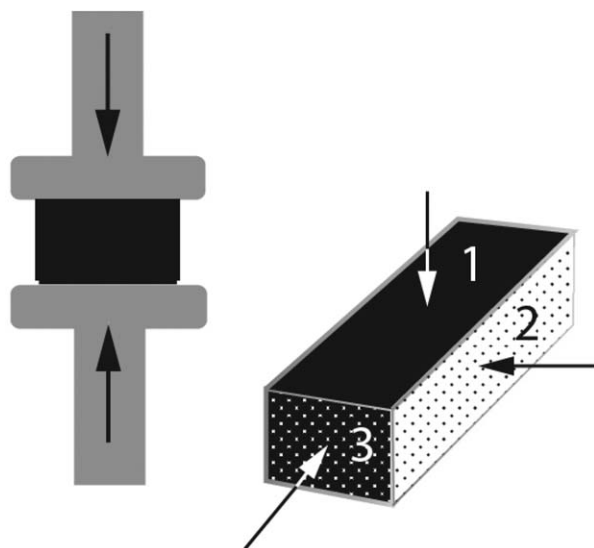

**FIGURE 1.** Schematic describing the three compression directions used to assess the mechanical integrity of the molded BVF polymer composite material.

mixture was compressed into a silicone mold (Grace Biolabs, dimensions 2 mm × 2 mm × 6 mm). Each mold had an adhesive backing and was adhered to the surface of a petri dish. A different mold adhered to a different petri dish was used for each formulation prepared. All molds were cleaned with acetone and 70% ethanol and allowed to dry between batches. Each Petri dish containing a mold was placed on the hot plate (preheated to 75°C) prior to packing. After all of the 2 mm × 2 mm × 6 mm rectangles of the silicone mold were filled with molten composite, the fragments were removed from the heat and allowed to cool in the mold for a minimum of 5 min up to 30 min at room temperature. Subsequently, a metal spatula was used to pry the BVF molded fragments from the mold. Each device was placed in a microcentrifuge tube and protected from light until use. Devices were either used the same day (control for shelf life studies) or stored according to the designated conditions for the shelf life study (Table II).

#### Device Quality Control Tests

The following quality control analyses were performed on all individual BVF molded fragments: (1) size measurements

including length, width, and height (spec: <10% deviation from standard), (2) weight measurement (spec: <5% deviation from standard),<sup>1</sup> and (3) qualitative assessment of surface roughness (spec: no visually apparent large defects). Visual inspection was performed on a dissecting microscope at 10× magnification from three areas on each surface. In addition, the following quality control tests were performed on batches intended for *in vitro* preclinical testing: (1) SEM images at 5×, 50×, and 500× were taken to evaluate for consistent texture and (2) mechanical tests were performed as outlined below.

#### Culture of *S. aureus* ATCC Strain 49230

ATCC *Staphylococcus aureus* strain 49230 was streaked from a TSB glycerol –80°C freezer stock onto a blood agar plate (5% sheep blood, BD Biosciences, USA) and allowed to grow up to 3 days at 37°C. For all ZOI studies, individual colonies were picked with an individual sterile cotton swab from a blood agar plate that was no more than 3-days-old into sterile saline. A solution of 10<sup>5</sup> CFU/mL in saline was made using a nephelometer (BD Biosciences) for use in all ZOI experiments immediately prior to use in the experiment. All liquid cultures of *S. aureus* were grown in Tryptic Soy Broth (TSB, BD Bioscience) + 10% fetal bovine serum (TSB). Note that serum was included to provide a rigorous bacterial challenge and to approximate the potential of serum protein to bind eluting antibiotic in a physiological environment, although this is not reported to be a significant issue for tobramycin.<sup>27</sup> Cultures were assessed for absorbance using spectrophotometry (OD = 600 nm) to determine growth curves.

#### Drug Release

Devices with varying tobramycin loads ( $n = 5$ ) were tested for drug release as previously described.<sup>14,21,22</sup> Briefly, tobramycin was released from fabricated devices into 3 mL of PBS. At each time point (24 h and each week through the remainder of the experiment), the complete release volume was drawn off and replaced with fresh PBS. To determine release kinetics, tobramycin in release media was derivatized with *o*-phthalaldehyde (OPA) and subsequently detected via fluorescence ( $\lambda_{\text{ex}} = 365 \text{ nm}$ ,  $\lambda_{\text{em}} = 460 \text{ nm}$ ), as previously described.<sup>21,22</sup> Additionally, release drug in 500  $\mu\text{L}$  was then dried down on a filter paper disc (6 mm

**TABLE II.** Summary and comparison of mechanical properties for molded BVF fragments containing antibiotic and polymer to those with only polymer (no drug). Compression tests were performed at two load rates and three test configurations (See Figure 1). Only direction had a significant effect on the mechanical properties with Direction 3 resulting in a higher modulus and lower ultimate stress.

		Direction 1		Direction 2		Direction 3	
		Rate 1	Rate 2	Rate 1	Rate 2	Rate 1	Rate 2
Rate 1 = 0.5 mm/min							
Rate 2 = 2.0 mm/min							
E(MPa)	Drug	187.72 (79.49)	226.19 (30.33)	180.35 (10.85)	182.85 (100.48)	558.13 (194.71)	455.11 (235.75)
	No Drug	225.38 (67.57)	217.46 (38.63)	210.15 (42.19)	163.69 (79.31)	490.49 (159.22)	464.07 (239.44)
$\sigma$ (MPa)	Drug	12.26 (1.97)	13.06 (1.44)	13.83 (1.12)	14.71 (1.06)	10.48 (1.76)	10.96 (2.01)
	No Drug	12.98 (3.03)	13.42 (1.51)	15.11 (2.13)	14.78 (1.89)	12.70 (2.53)	13.99 (1.10)

Values reported as "Mean (St.Dev.)"

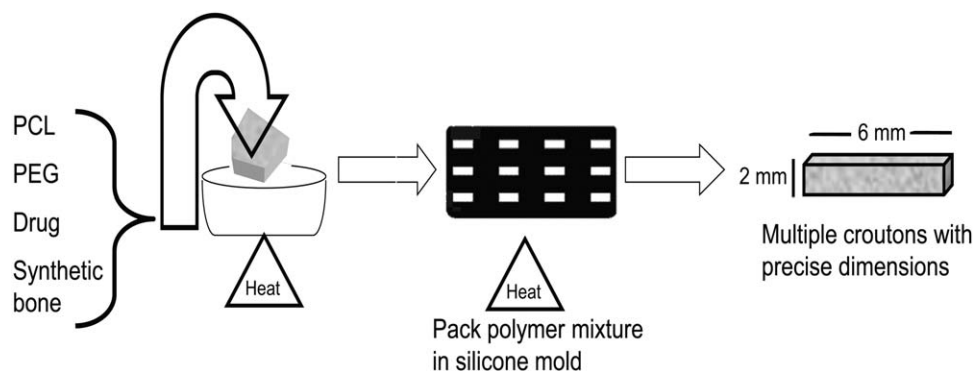

**FIGURE 2.** Schematic view of the fabrication process for a molded degradable polymer-ceramic composite bone void filler containing controlled-release capability for antibiotic.

diameter) as previously described.<sup>21,22</sup> These discs were then placed on a Brain Heart Infusion (BHI) agar plate streaked with  $10^5$  CFU/mL (determined using a nephelometer) *S. aureus* (ATCC strain 49230) and allowed to grow for 16 h at 37°C. The ZOI around each disc was measured with calipers and reported as an average of replicate samples ( $n = 3-5$ ).

A modified minimal inhibitory concentration<sup>7</sup> assay for time kill was performed to test drug antimicrobial activity. Drug-releasing devices were placed in 2 ml of TSB+10% FBS and  $10^5$ ,  $10^7$ , or  $10^9$  CFU of *S. aureus* (ATCC strain 49230) were inoculated into the media. Experiments were performed in triplicate. Samples were allowed to grow for 48 h at 37°C with shaking (125 RPM). The optical density (600 nm) of the media was measured at 30 min, 1 h, 2 h, 4 h, 8 h, 24 h, and 48 h to create a bacterial growth curve. Nondrug releasing (polymer blend-ProOsteon composite only) devices were used as controls.

### Mechanical Testing

Antibiotic-loaded composite BVF samples were subjected to unconfined uniaxial compression across 3–5 identically prepared 2 mm × 2 mm × 6 mm rectangular samples, fabricated as described above. Tests were performed on an Instron 5943 mechanical testing system controlled by an interfaced computer. Compression tests were performed by subjecting samples to a linearly applied load until failure, defined by a 40% decrease in maximum stress. Samples were tested at two load rates (0.5, 2.0 mm/min) selected to represent rates corresponding to walking and running.<sup>29</sup> Samples were also tested along three principal axes to determine anisotropic behavior (Figure 1).

### Shelf Life Study

Fabricated devices made as described above were stored in individual microcentrifuge tubes under ambient air. Multiple tubes containing implants for each condition were sealed in plastic bags and stored in the dark at  $-20^{\circ}\text{C}$ ,  $4^{\circ}\text{C}$ ,  $25^{\circ}\text{C}$ , and  $55^{\circ}\text{C}$  for 24 h, 1 week, 1 month, and 2 months in all combinations ( $n = 3$ ). Morphology (SEM), mechanical tests, and ZOIs as outlined above were performed on each sample

( $n = 3-5$ ) to determine if storage affected activity of the released antibiotic, mechanics of the device, or accelerated polymer degradation.

### Statistics

Significance was determined ( $p < 0.05$ ) using a one-way analysis of variance for all ZOI experiments and kinetics experiments. A three-way analysis of variance was performed to assess the effect of direction, rate, and presence/absence of drug on the ultimate strength and Young's modulus of the bone graft samples from compression. Storage and temperature effects on mechanical integrity were evaluated by comparing all specimens to control samples (1 week post-manufacturing stored at room temperature) using a Dunnett's test.

### RESULTS

Bone graft (commercial clinically used BVF hybrid coralline product) was morselized and exhibited a median size of approximately 410  $\mu\text{m}$  ( $n = 2$ ) with a substantial size range of 34–1020  $\mu\text{m}$  (data not shown). Less than 5% of the morselized particulate fell outside this size range. It was subsequently sieved to isolate particle sizes between 125 and 400  $\mu\text{m}$  for inclusion in the antibiotic-eluting BVF composite. Fabricated antibiotic-eluting coralline BVF was produced as outlined in the materials and methods in batches of 10–12 with dimensions of 2 mm × 2 mm × 6 mm  $\pm 10\%$  for each dimension as determined by caliper measurements (Figure 2). Each fragment was also weighed to find an average weight (data not shown). If the weight of any individual fragment fell greater than 10% outside the average weight, that fragment was excluded from all additional analysis. Regardless of the ratio of the polymer components in each specific batch (see Table I), the inorganic materials fraction comprised at least 60% of the bulk weight and the drug portion was maintained at 10% w/w. Importantly, fragments extracted from the silicon mold were not friable and were easily handled, having more malleability with increasing PEG content. This protocol was easily scalable and customizable, exhibiting distinct advantages over previous coating/fabrication techniques. Quality control steps

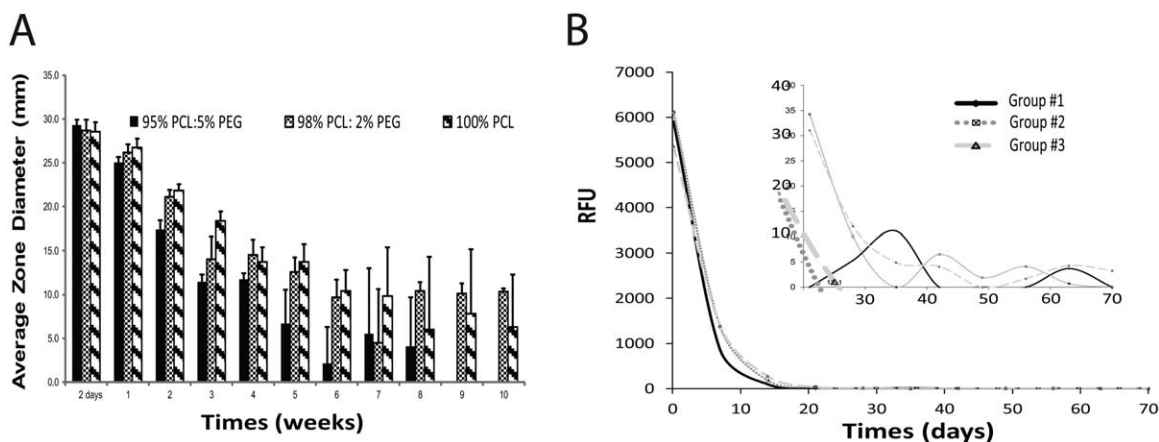

**FIGURE 3.** A: To further characterize the polymer control of antibiotic release, a fluorescence assay was performed measured as Relative Fluorescence Units (RFU). Although it appears that all drug is released by 20 days, the inset in the graph shows that drug is still being released. B: To further characterize and confirm bioactivity of synthetic, antibiotic-containing fragments based on a difference in the ration of PCL to PEG, zone of inhibition studies using *S. aureus* strain 42930 were performed. Regardless of the ratio of the polymers, antibiotic activity is extended to at least 8 weeks. Note that as the amount of PEG is increased the duration of bioactivity is decreased. With increasing amounts of PCL it is evident that bioactivity should extend beyond 10 weeks. For Group description see Table 1.

including assessments of weight, dimensionality, and smoothness for each device as well as SEM and mechanical testing were performed for each batch.

Device homogeneity was assessed via mechanical testing along multiple axes (Figure 1). While this bone graft was not intended for structural support but merely as void filler to support host bone regeneration, the structural properties are important to ensure the mechanical quality of grafting and to ensure that drug loading does not compromise graft properties. Devices were mechanically characterized in 3 different directions, at two different rates, and with or without the antibiotic (Table II). A three-way ANOVA ( $p < 0.05$ ) across all variables showed no significant differences with load rate or between specimens with and without antibiotic. Compressive ultimate stress in Direction 3 was significantly reduced compared to the other directions [ $p < 0.05$ , Figure 4(A)], and the elastic modulus of the device tested in Direction 3 was significantly increased [ $p < 0.001$ , Figure 4(B)] suggesting that the specimens are transversely isotropic.

After characterizing the physical properties of fragments from each batch ( $n = 3-5$ ), drug release kinetics were assessed based on the different ratios of PCL to PEG, which were predicted to change the porosity of the matrix and consequently, the rate of drug elution from the antibiotic-loaded BVF composites (shown in Table I). A published fluorescence assay (LOD = 0.0625 mg/mL) based on derivatization of tobramycin with OPA was performed to determine drug release [see Figure 3(a)].<sup>22</sup> The inset in the Figure 3(B) shows that measurable tobramycin release was observed throughout the 8-week assay period.

Since the kinetics assay used cannot specifically determine the amount of tobramycin released,<sup>22</sup> antimicrobial activity above the MIC (previously determined to be 4 micrograms/mL), was assessed using ZOI assays. Regardless of the polymer ratio, antibiotic *in vitro* killing activity against *S. aureus* was observed to at least 8 weeks. Not surprisingly, as the PEG fraction of the BVF composite was increased, the duration of antimicrobial activity decreased (i.e., release kinetics were faster). Conversely, increasing

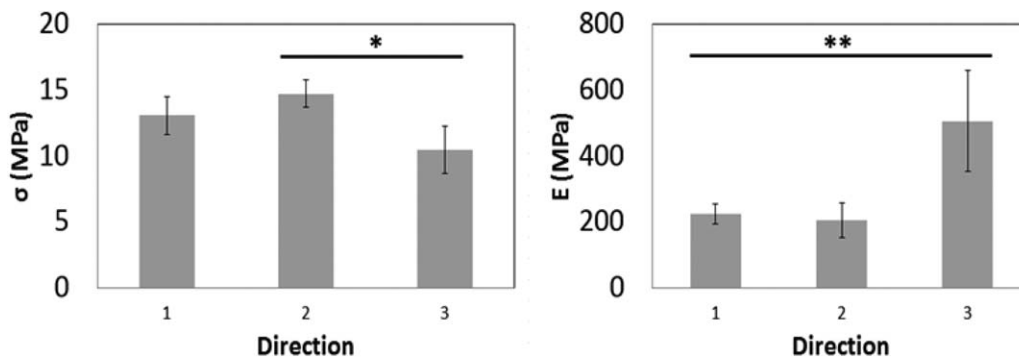

**FIGURE 4.** Summary of molded composite mechanical characterization plotted as (A) ultimate stress ( $\sigma$ ) or (B) Young's modulus ( $E$ ) versus the three compression directions. Load rate and the presence/absence of drug had no significant effect on material properties, so all data points were combined in the above plots. Direction 3 had significantly lower ultimate stress ( $*p < 0.05$ ) than Direction 2, and a significantly higher Young's modulus ( $**p < 0.001$ ) than Direction 1 and 2, representative of a transversely isotropic material.

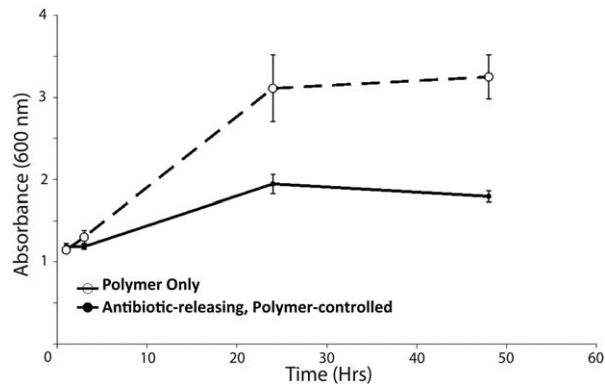

**FIGURE 5.** *S. aureus* strain 42930 growth rates as monitored by optical absorbance (y-axis, wavelength 600 nm) in the presence of polymer-controlled, antibiotic-releasing bone composite matrix compared to a non-antibiotic-containing counterpart.

amounts of PCL in the device prolonged killing durations and indicated that antimicrobial activity may extend beyond 10 weeks (see Figure 4).

The limit of antimicrobial activity was investigated *in vitro* based on a modified MIC time kill study (Figure 5). The growth rate of *S. aureus* ATCC strain 49230 bacteria, indicated by optical absorbance (600 nm) in the presence of antibiotic-releasing BVF composite, was compared with non-antibiotic containing controls *in vitro* ( $n = 3$ ). Even at a high bacterial inoculum ( $10^9$  CFU *S. aureus*), the antibiotic-containing BVF composite was able to control bacterial growth over 48 h. In an analogous experiment where antibiotic-releasing bone graft or its antibiotic-free control were embedded in nutrient agar and  $10^9$  CFU *S. aureus*

were spread on the nutrient agar surface, bacteria were unable to grow and no colonies were noted on the antibiotic-releasing bone graft after 48 h ( $n = 5$ ) (data not shown) while controls showed no such inhibition.

To assess the stability of antibiotic incorporated in the BVF composite, drug elution kinetics and antimicrobial properties were determined after storage at one of four temperatures, protected from light for a designated period of time (Figure 6). Fragments ( $n = 3-5$ ) were removed from storage conditions at designated time points and assessed for drug release into PBS. SEM imaging, was also done at each time point to assess polymer degradation as indicated by amount of coralline BVF visible in the images. Dark areas within each SEM were polymer whereas the lighter areas were the inorganic materials as evident from pure polymer or pure BVF controls.<sup>21</sup> Based on these images, it is apparent that more BVF is visible after 1 month storage at 55°C. Nevertheless, device storage did not result in distinguishable changes to the drug release kinetics (Figure 7). Antimicrobial activity of tobramycin released from the stored samples, as determined by ZOI studies, regardless of the storage time at -20°C, 4°C, 22°C, and 55°C retained strong activity against *S. aureus* for the entire study duration (Figure 8).

Mechanical compressive strength of stored devices was also determined. Specimens containing antibiotic were evaluated by compressing in Direction 3 at a load rate of 2 mm/s. Figure 9 shows compressive stress and modulus after 1 and 2 months of storage in each condition as indicated. Compared to control specimens stored for 1 week at room temperature, ultimate stress significantly ( $p < 0.0001$ ) increased for after 1 and 2 months of storage. The moduli also slightly increased after 1 and 2 month storage, but

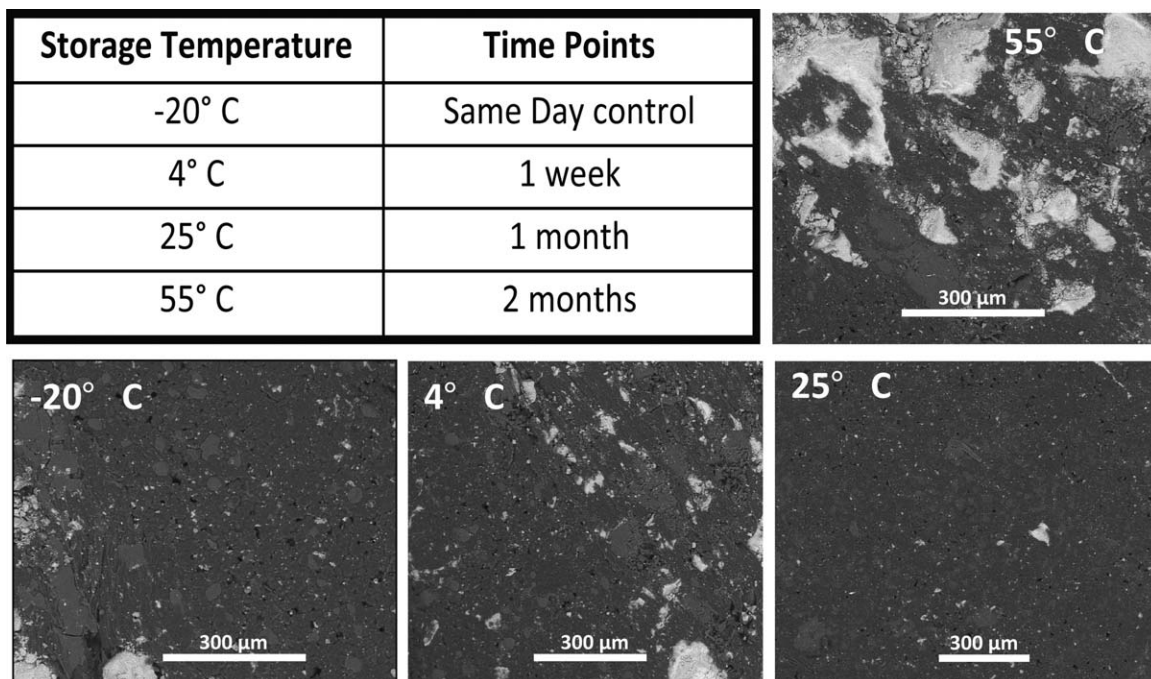

**FIGURE 6.** Evaluation of storage conditions. Polymer-controlled, antibiotic-releasing bone fragments were stored at one of four temperatures and evaluated at each time point shown in the table above. An example of SEM images from 1 month storage is shown. Scale bar = 300 microns.

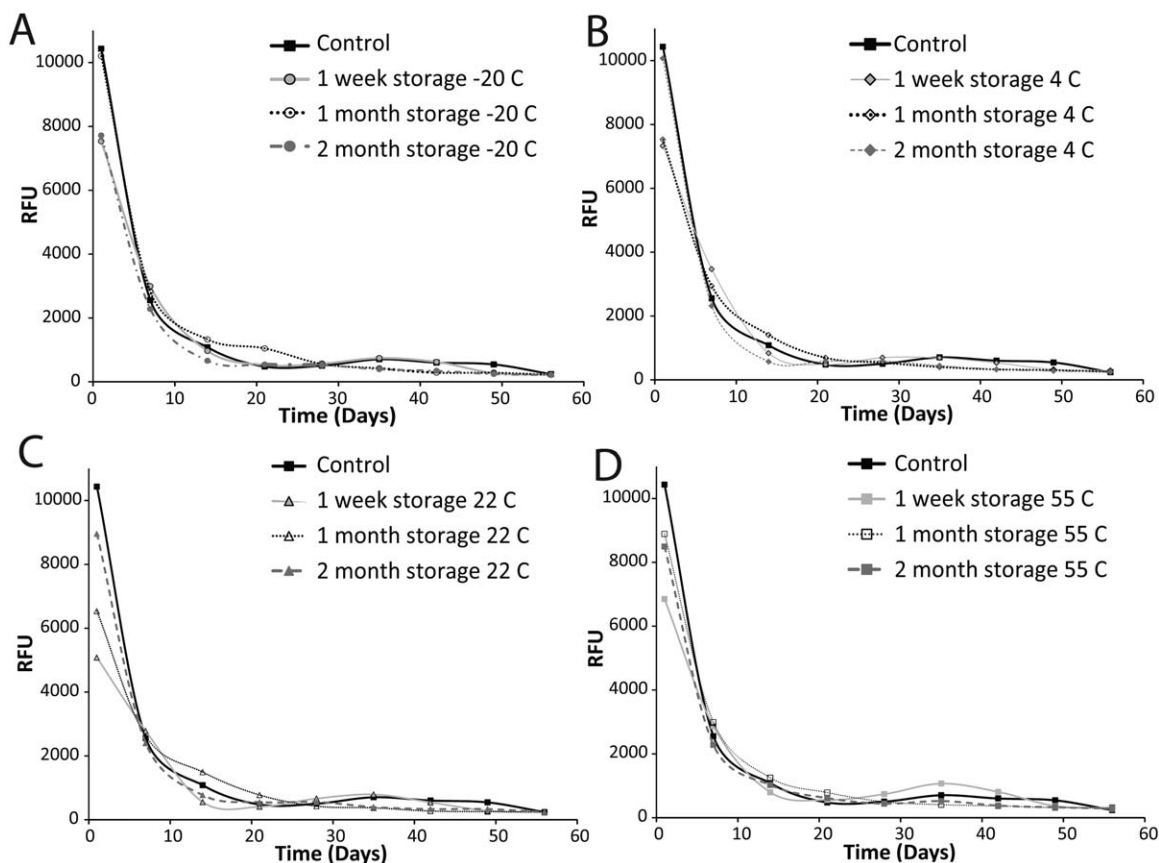

**FIGURE 7.** Release kinetics of tobramycin in implant as detected by a fluorescence assay (RFU, relative fluorescence unit) based on the derivatization of tobramycin with OPA. A: Samples were stored  $-20^{\circ}\text{C}$ . B: Samples were stored and  $4^{\circ}\text{C}$ . C: Samples were stored at  $\sim 22^{\circ}\text{C}$ . D: Samples were stored at  $55^{\circ}\text{C}$ . After 1 day, the release is indistinguishable from the control fragments that were not stored prior to release.

were not statistically significant ( $p \geq 0.27$ ) for all comparisons due to larger variability. Storage temperature had no effect on either of the mechanical parameters and no significant differences were found between the 1 and 2 month specimens. These data suggest that the devices generally increase their mechanical integrity after 1 month of storage and maintain it for at least an additional month of storage, regardless of the storage condition. One exception to this may be the specimens stored at  $55^{\circ}\text{C}$  which exhibited a slight degradation after 2 months, although this was also not statistically significant.

## DISCUSSION

Despite the diversity of different BVFs available for clinical use, all are variations of porous calcium-based inorganic scaffold biomaterials, either synthetic or human-derived. Regardless of the specific BVF implanted, its use in arthroplasty still represents a nonviable foreign body in tissue with the associated risks of adverse host inflammatory response and susceptibility to infection. This is reflected in the clinical difficulties addressing orthopedic infections in TJR surgeries<sup>23,24,30</sup> and the increasing use of antibiotic-containing bone cements.<sup>31,32</sup> Unfortunately, very few BVFs release antibiotics and those that do release drugs (e.g.,

OSTEOSET<sup>®</sup> T, etc.) suffer from early burst release, which limits their duration to far shorter than the clinical target of 6–8 weeks.<sup>7,25</sup> Thus, extended antibiotic release, beyond the initial early burst release phase, is necessary to address the threat of persistor pathogens in the implant site and adjacent tissues. Importantly, extended antibiotic release may eliminate these cells that can resist acute-phase antimicrobial exposure to produce later-stage infections and potentially give rise to antibiotic resistant pathogens.<sup>33</sup> Previous efforts by Brooks et al reported synthetic or cadaveric allograft BVF either spray-coated or dip-coated with an antibiotic-containing degradable polymer coating<sup>14</sup>; however, the heterogeneity of both cancellous allograft croutons and polymer/drug dip-coating procedures produced challenges with inconsistent coating homogeneity and drug loading. The fabrication process described in this manuscript sought to avoid the pitfalls of earlier efforts, which were time-consuming and tedious, while maintaining or improving drug releasing performance.

Antibiotic-releasing bone substitutes often consider the immediate peri- and post-operative acute contamination risk periods as crucial for eliminating pathogens threatening the implant site.<sup>35–37</sup> Drug delivery in these current BVF systems is generally a short, intense burst effect within the first few days of implantation, which quickly exhausts the drug load,

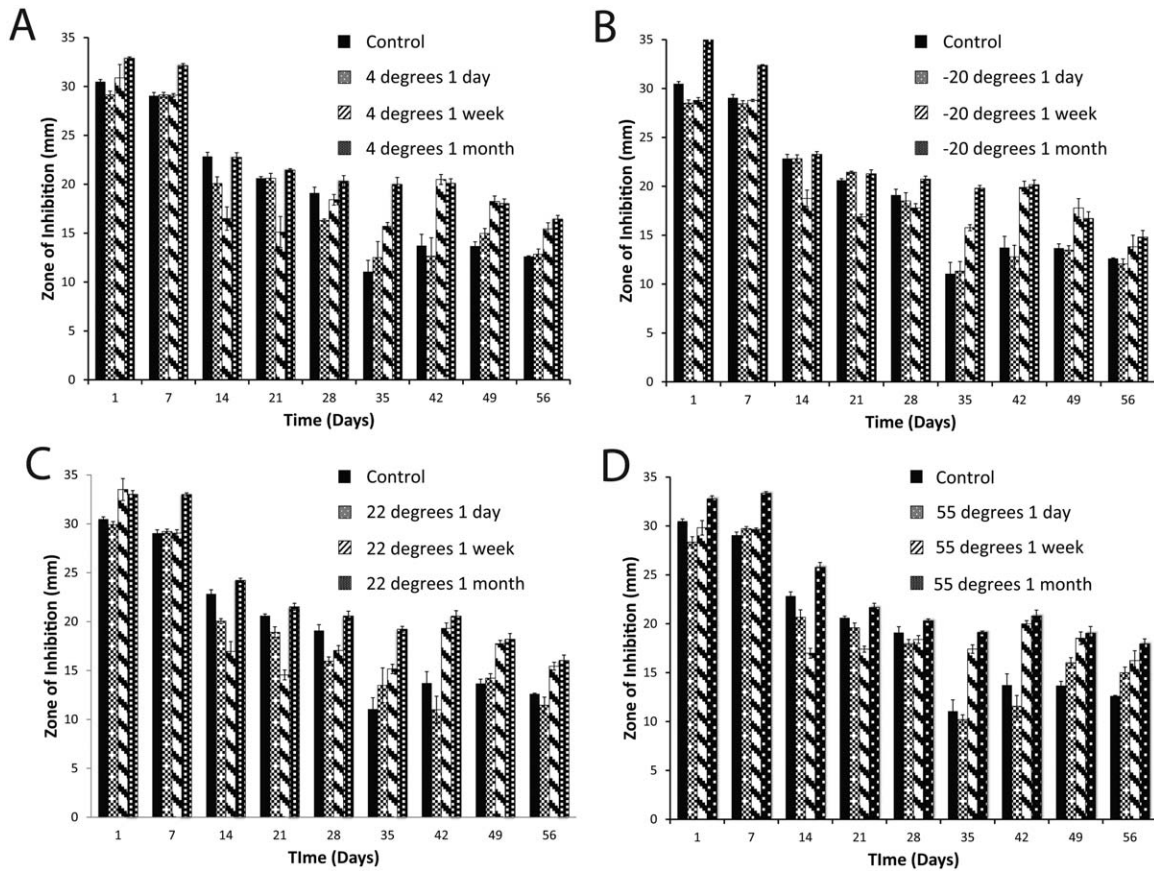

**FIGURE 8.** Antimicrobial activity of released tobramycin as determined by Zone of Inhibition assays with *S. aureus* strain 49230 to 8 weeks. Molded composite materials were stored at various temperatures shown for 1 week, 1 month, or 2 months and then drug was released into PBS to 8 weeks. Release data shown for samples stored at (A)  $-20^{\circ}\text{C}$ , (B)  $4^{\circ}\text{C}$ , (C)  $22^{\circ}\text{C}$ , and (D)  $55^{\circ}\text{C}$  and times indicated.

providing rapid, local antimicrobial protection above the MIC for several days<sup>35–37</sup> but not longer. This applies also to clinically popular antibiotic-releasing bone cements (distinct from BVFs), but in this case, up to 50% or more of the antibiotic

load is trapped within the polymerized cement matrix and does not release.<sup>12,20,38</sup> Such a rapid burst release is often not indicative of a true controlled drug delivery, but merely surface blooming of drug often due to phase separation. To

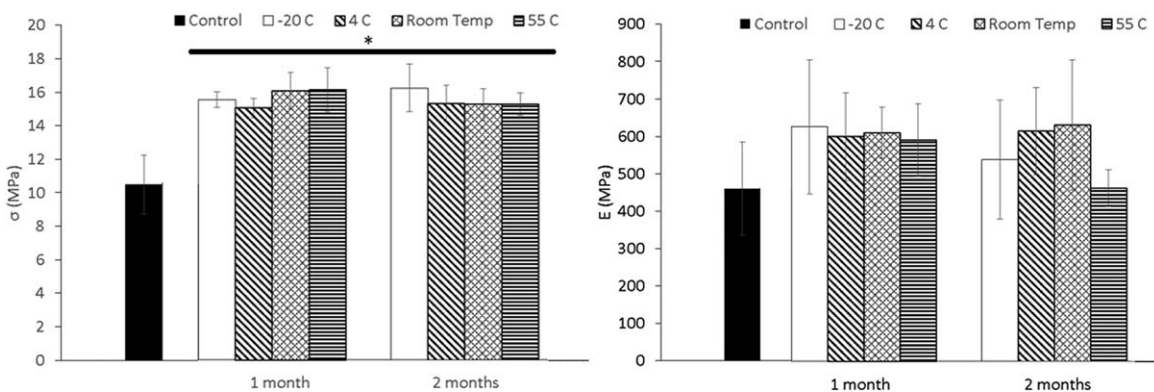

**FIGURE 9.** Shelf life and storage effects on the ultimate stress (A) and modulus (B) of molded BVF composite devices tested after 1 and 2 months of storage resulted in higher ultimate stress and moduli than controls stored for only 1 week, but only ultimate stress was significant ( $*p < 0.001$ ). Storage temperature did not significantly affect the mechanical integrity, including specimens stored at  $55^{\circ}\text{C}$  which did exhibit a slight degradation in the modulus after 2 months. Group 2 fragments.



avoid the uncontrolled release that often plagues local delivery systems, differences in the Hildebrand constants and phase separation between the polymer components based on their relative rates of polymer crystallization<sup>39–41</sup> justified the use of PEG to induce domains within the cast blended polymer BVF composite to provide porosity via aqueous permeation, PEG dissolution, and extraction from the polymer matrix.<sup>14</sup> This intended polymer matrix skeletonization and porosity impacts the tobramycin release kinetics by transitioning device release mechanisms from aqueous permeation/dissolution-limited to drug diffusion-limited kinetics. Importantly, storage at various temperatures did not appear to significantly compromise drug release, as indicated by the elution kinetics and ZOI of fragments stored for 2 months prior to releasing the antibiotic into PBS.

Although the antimicrobial properties of the BVF composite were thoroughly characterized in the course of this study, the primary mode of action for the antibiotic-eluting BVF composite is intended as a void filling graft without the necessity for structural support.<sup>42</sup> Nevertheless, an analysis of the mechanical integrity of the release system is also crucial, revealing detail about the consistency of the fabrication process and the impact of antibiotic incorporation. Unlike antibiotic cement, compression testing of the BVF composite device revealed that inclusion of drug solids does not significantly compromise the device's mechanical integrity (Table II). Furthermore, storage of the antibiotic BVF composite up to two months did not significantly reduce the mechanical integrity of the specimen. Mechanical testing along different axes of the BVF (Figure 1) provides an indication of the structural anisotropy of the composite BVF. Regardless of compressive direction, compressive stress ( $\sigma$ ) was between 12 and 15 MPa and modulus ( $E$ ) from directions 1 and 2 was  $\sim 200$  MPa; whereas, from direction 3 (long dimensional axis),  $E$  was  $\sim 500$  MPa. Importantly, the ProOsteon 500R<sup>TM</sup> synthetic BVF inorganic material comprising the majority mass component was reported to have similar compressive strength and modulus as cancellous bone (5.5 MPa).<sup>15,42</sup> Other common BVFs can be divided into five main categories: hydroxyapatite, tricalcium phosphates, composites, calcium sulfate, and bioactive glass, each producing varied compressive strengths and moduli. However, those values obtained for the current BVF system fall within this same range with compressive strengths similar to hydroxyapatite (e.g., Cerabone, Endobon, etc.) and moduli similar to some of the composite BVFs (e.g., HydroSet, etc.).<sup>43</sup>

The BVF combination device described here represents a second-generation bone graft concept from the initial reporting,<sup>14</sup> embodying not only improved molded fabrication (i.e., consistency, ease, etc.) but also enhanced drug delivery and antimicrobial activity (e.g., for tobramycin, a release greater than 10 weeks, Figure 2). The new composite molding process also provides not only versatility in BVF molded morphology, but also a moldable, carvable product suited to bone bed and implant wound site to minimize/prevent formation of inadvertent avascular dead spaces (Figure 1). Additionally, reduced PCL and PEG molecular

weights in this composite result in a moldable putty-like solid BVF. On the basis of the studies described here, the process specifically provides: (1) more streamlined fabrication, (2) accessible quality control measures,<sup>1</sup> (3) ability to maintain shelf life for up to 1 year, as indicated by consistent drug release and bioactivity over 60 days shelf life at 55°C, a condition reported to be equivalent to 1 year of room temperature storage, (4) desirable and tailored drug release kinetics for long periods based on a PEG polymer poragen within the blended degradable polycaprolactone matrix, and (5) mechanical integrity that avoids friability and handling issues for practical deployment into implant sites. This versatile platform can accommodate different antibiotics and drugs for release, even in combinations. Future work will focus on *in vivo* performance and anti-infective efficacy for this combination medical device in pre-clinical infection models.

#### ACKNOWLEDGMENTS

The authors acknowledge J. DeGooyer for helping with device fabrication and Dr. A. Khandkar for morselized granule sizing.

#### REFERENCES

- Jiranek WA, Hanssen AD, Greenwald AS. Antibiotic-loaded bone cement for infection prophylaxis in total joint replacement. *J Bone Jt Surg* 2006;88:2487–2500.
- Kurtz SM, Lau E, Ong K, Zhao K, Kelly M, Bozic KJ. Future young patient demand for primary and revision joint replacement: National projections from 2010 to 2030. *Clin Orthop* 2009;467:2606–2612.
- Conterno LO, da Silva Filho CR. Antibiotics for treating chronic osteomyelitis in adults. *Cochrane Database Syst Rev* 2009;3.
- Landersdorfer CB, Bulitta JB, Kinzig M, Holzgrabe U, Sörgel F. Penetration of antibacterials into bone. *Clin Pharmacokinet* 2009;48:2009.
- Kurtz SM, Lau E, Watson H, Schmier JK, Parvizi J. Economic burden of periprosthetic joint infection in the United States. *J Arthroplasty* 2012;27:61–65.e1.
- Kurtz SM, Lau E, Schmier J, Ong KL, Zhao K, Parvizi J. Infection burden for hip and knee arthroplasty in the United States. *J Arthroplasty* 2008;23:2008.
- Brooks BD, Brooks AE, Grainger DW. Antimicrobial medical devices in preclinical development and clinical use. In: Moriarty TF, Zaat SAJ, Busscher HJ, editors. *Biomaterials Associated Infection*. New York: Springer; 2013. pp 307–354.
- Richards RG, Moriarty TF, Miclau T, McClellan RT, Grainger DW. Advances in biomaterials and surface technologies, *J Orthop Trauma* 2012;26:703–707.
- Vasilev K, Cook J, Griesser HJ. Antibacterial surfaces for biomedical devices. *Expert Rev Med. Devices* 2009;6:553–567.
- Simchi A, Tamjid E, Pishbin F, Boccaccini AR. Recent progress in inorganic and composite coatings with bactericidal capability for orthopaedic applications. *Nanomed Nanotechnol Biol Med* 2011;7:22–39.
- Gunnam R. The future of orthopedic implants analysis and forecasts to 2016. GBI Research, 2010.
- Bostrom MP, Seigerman DA. The clinical use of allografts, demineralized bone matrices, synthetic bone graft substitutes and osteoinductive growth factors: A survey study. *HSS J* 2005;1:9–18.
- Giannoudis PV, Dinopoulos H, Tsiridis E. Bone substitutes: An update. *Injury* 2005;36:S20–S27.
- Brooks AE, Brooks BD, Davidoff SN, Hoglebe PC, Fisher MA, Grainger DW. Polymer-controlled release of tobramycin from bone graft void filler. *Drug Deliv Transl Res* 2013;3:518–530.
- Nandi SK, Roy S, Mukherjee P, Kundu B, De DK, Basu D. Orthopaedic applications of bone graft and graft substitutes. *Indian J Med Res* 2010;132:15–30.

16. Costerton JW. The etiology and persistence of cryptic bacterial infections: A hypothesis. *Clin Infect Dis* 1984;6:S608–S616.
17. Kanellakopoulou K, Giamarellos-Bourboulis EJ. Carrier systems for the local delivery of antibiotics in bone infections. *Drugs* 2000; 59:1223–1232.
18. Koort JK, Suokas E, Veiranto M, Mäkinen TJ, Jalava J, Törmälä P, Aro HT. In vitro and in vivo testing of bioabsorbable antibiotic containing bone filler for osteomyelitis treatment. *J Biomed Mater Res A* 2006;78:532–540.
19. McKee MD, Wild LM, Schemitsch EH, Waddell JP. The use of an antibiotic-impregnated, osteoconductive, bioabsorbable bone substitute in the treatment of infected long bone defects: Early results of a prospective trial. *J Orthop Trauma* 2002;16:622–627.
20. Winkler H, Stoiber A, Kaudela K, Winter F, Menschik F. One stage uncemented revision of infected total hip replacement using cancellous allograft bone impregnated with antibiotics. *J Bone Joint Surg Br* 2008;90:1580–1584.
21. Davidoff SN, Call BP, Hogrebe PC, Grainger DW, Brooks AE. A robust method to coat allograft bone with a drug-releasing polymer shell—biomed 2010. *Biomed Sci Instrum* 2010;46:184.
22. Sevy JO, Slawson MH, Grainger DW, Brooks AE. Assay method for polymer-controlled antibiotic release from allograft bone to target orthopaedic infections—biomed 2010. *Biomed Sci Instrum* 2010;46:136.
23. Garvin KL, Hinrichs SH, Urban JA. Emerging antibiotic-resistant bacteria: Their treatment in total joint arthroplasty. *Clin Orthop* 1999;369:110–123.
24. Guide to the Elimination of Orthopedic Surgical Site Infections. APIC, 2010.
25. Brooks BD, Davidoff SN, Grainger DW, Brooks AE. Comparisons of release of several antibiotics from antimicrobial polymer-coated allograft bone void filler. *International Journal of Biomedical Materials Research*. 2014 (In Press).
26. Mousset B, Benoit MA, Delloye C, Bouillet R, Gillard J. Biodegradable implants for potential use in bone infection. *Int Orthop* 1995; 19:157–161.
27. Begg EJ, Barclay ML. Aminoglycosides—50 years on. *Br J Clin Pharmacol* 1995;39:597–603.
28. Brandl M, Gu L. Degradation of tobramycin in aqueous solution. *Drug Dev Ind Pharm* 1992;18:1423–1436.
29. Biewener AA, Taylor CR. Bone strain: A determinant of gait and speed? *J Exp Biol* 1986;123:383–400.
30. Pulido L, Ghanem E, Ashish Joshi MPH, Purtill JJ. Periprosthetic joint infection: The incidence, timing, predisposing factors. *Clin Orthop* 2008;466:1710–1715.
31. Bourne RB. Prophylactic use of antibiotic bone cement: An emerging standard—in the affirmative<sup>1</sup>. *J Arthroplasty* 2004;19: 69–72.
32. Terry AC, Quanjun C. Antibiotic laden cement: Current state of the art. AAOS.
33. Schmidmaier G, Gahukamble AD, Moriarty TF, Richards RG. Infection in fracture fixation: Device design and antibiotic coatings reduce infection rates. Moriarty TF et al (Eds) *In Biomaterials Associated Infection: Immunological Aspects and Antimicrobial Strategies*, Springer, 2013, pp. 435–453.
34. Wenke JC, Owens BD, Svoboda SJ, Brooks DE. Effectiveness of commercially-available antibiotic-impregnated implants. *J Bone Joint Surg Br* 2006;88:1102–1104.
35. Winkler H, Kaudela K, Stoiber A, Menschik F. Bone grafts impregnated with antibiotics as a tool for treating infected implants in orthopedic surgery—One stage revision results. *Cell Tissue Bank* 2006;7:319–323.
36. Witsø E, Persen L, Løseth K, Bergh K. Adsorption and release of antibiotics from morselized cancellous bone. In vitro studies of 8 antibiotics. *Acta Orthop Scand* 1999;70:298–304.
37. Witsø E, Persen L, Løseth K, Benum P, Bergh K. Cancellous bone as an antibiotic carrier. *Acta Orthop Scand* 2000;71:80–84.
38. Roberts JA, Kruger P, Paterson DL, Lipman J. Antibiotic resistance—What's dosing got to do with it? *Crit Care Med* 2008;36: 2433–2440.
39. Chuang WT, Jeng US, Sheu HS, Hong PD. Competition between phase separation and crystallization in a PCL/PEG polymer blend captured by synchronized SAXS, WAXS, DSC. *Macromol Res* 2006;14:45–51.
40. Wei-Tsung Chuang KSS. Kinetics of phase separation in poly( $\epsilon$ -caprolactone)/poly(ethylene glycol) blends. *Journal of Polymer Research*. 2005;12(3):197–204. doi: 10.1007/s10965-004-1868-9.
41. Liu KL, Widjaja E, Huang Y, Ng XW, Loo SCJ, Boey FYC, Venkatraman SS. A new insight for an old system: Protein-PEG colocalization in relation to protein release from PCL/PEG blends. *Mol Pharm* 2011;8:2173–2182.
42. Moore WR, Graves SE, Bain GI. Synthetic bone graft substitutes. *ANZ J Surgery* 2001;71:354–361.
43. Van der Stok J, Van Lieshout EMM, El-Massoudi Y, Van Kralingen GH, Patka P. Bone substitutes in the Netherlands—A systematic literature review. *Acta Biomater* 2011;7:739–750.