

Proximity Detection Zones

Designs to Prevent Fatalities Around Continuous Mining Machines

By Peter T. Bissert, Jacob L. Carr and Joseph P. DuCarme

Mine workers in an underground coal mine are exposed to many hazards and potential hazards on a daily basis such as unstable mine openings, coal and rock dust, high noise levels, fires and explosions, and heavy machinery. While many engineering and process controls have been established to mitigate the risks of these hazards, working with and in proximity to large, mobile equipment remains a significant risk to miner safety.

Some of the most hazardous jobs for an underground coal miner involve operating or working in the vicinity of continuous mining machines (CMMs). Since 1984, 39 miners have been killed when struck or pinned by a CMM (MSHA, 2015).

A common coal mining method in the U.S. is the room-and-pillar method, in which coal is cut and removed from the earth in a grid-like pattern of

openings called entries and cross-cuts (Figure 1). CMMs (Photo 1) are used extensively in room-and-pillar mining.

CMMs feature a large cutting drum that cuts coal from the seam, gathers it into the pan, and conveys it back through the boom for haulage (Figure 2). They are typically operated by remote control, allowing the operator to remain at a safe distance

IN BRIEF

- Underground coal extraction commonly utilizes remote-controlled crawler-mounted heavy equipment known as continuous mining machines that cut coal from the solid formation.
- Miners working with or near these machines are regularly exposed to the risk of serious injury from being struck or pinned.
- Based on an analysis of 39 fatalities involving continuous mining machines, it is estimated that proximity detection systems can help prevent such injuries by preventing hazardous machine movements.
- Design of proximity detection zones significantly affects the effectiveness of intelligent proximity detection systems.

Figure 1

Room & Pillar Mining Method

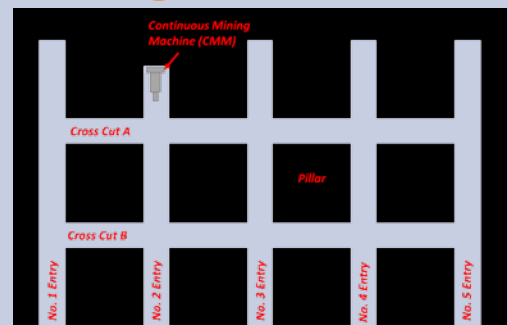

Peter T. Bissert works at NIOSH's Pittsburgh Mining Research Division (PMRD). He has been involved with research on proximity detection systems and refuge alternatives, and will be leading a project on mine escape technologies that will focus on utilizing thermal imaging cameras, air and gas monitoring, and various localization techniques to help miners escape post-disaster. He holds a B.S. in Mechanical Engineering from Pennsylvania State University, and an M.S. in Mechanical Engineering from Carnegie Mellon University.

Jacob L. Carr holds a B.S. and an M.S. in Mining Engineering from the University of Nevada, Reno, where he also performed research on the computer-assisted control of surface mining equipment and on heat and mass transport in rock. Since joining NIOSH's PMRD he has conducted research on underground mine illumination, communications and tracking, proximity detection and lockout/tagout. Currently, he is working with industry partners to transfer the developments in proximity detection and lockout/tagout into common use in the mining industry. Carr is pursuing a Ph.D. at Penn State.

Joseph P. DuCarme is a senior mechanical engineer in the Electrical and Mechanical Systems Safety Branch at the PMRD Laboratory. His research has focused on proximity detection for continuous mining machines, development of intelligent lockout/tagout technology for stationary machinery, and various investigations and analyses related to machine safety. DuCarme holds a B.S. in Mechanical Engineering from University of Pittsburgh.

Figure 2
CMM Components

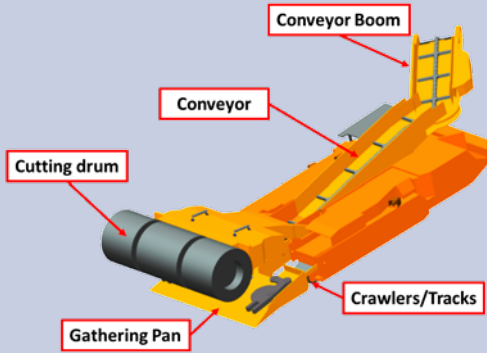

from the machine when coal is being cut from the solid formation. In many cases, due to limited visibility and space, operators may work in close proximity to a CMM. This may put the operator in danger of being struck by the machine or pinned between the machine and the ribs or roof (walls or ceiling of the mine opening).

To prevent such incidents, proximity detection systems have been developed and are now required on all CMMs in underground coal mines, with the exception of full-faced CMMs (MSHA, 2015). Full-face CMMs mine the entire width of an entry and have integral roof bolting equipment, which require miners to ride onboard the machine. Proximity detection systems feature several (typically four) electromagnetic field generators installed on CMM machines, while miners wear personal alarm devices (PADs). The governing principle is that the closer a PAD-equipped miner gets to the CMM, the higher the electromagnetic field strength. When a miner is detected in hazardous proximity to the CMM, the proximity detection system first provides a visual and audible warning to indicate a warning zone incursion, then if the miner enters the stop zone, it completely halts all machine tram and conveyor boom functionality.

The shapes and sizes of these zones represent predefined distances from the machine, and are configured via hardware settings or software. The zones are static except when the CMM is cutting coal. Known as mining mode, this feature reduces the zones toward the rear of the machine to allow the operator to get out of the way of oncoming shuttle cars. Note that machine motions that could harm the operator (such as a conveyor boom swing) are not prevented during mining mode. Figure 3 illustrates an example set of warning and stop zones. For the remainder of this article, systems with zones of this type will be referred to as conventional proximity detection systems.

NIOSH researchers have developed the intelligent proximity detection (iPD) system, which differs from conventional systems in that it utilizes multiple stop zones to selectively disable potentially dangerous machine motions while allowing safe motions to continue uninterrupted. This is accomplished by utilizing all of a CMM's generators to determine the position of the miner relative to the machine through trilateration, whereas conventional proximity detection system zone incursions are a result of a high electromagnetic reading when a miner gets within a predefined distance of the CMM.

Figure 3
Conventional Proximity Detection System Zones

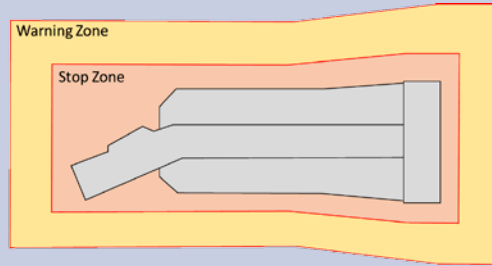

Photo 1: Example of a CMM showing the cutting drum.

By defining specific zones in which only select machine actions are prevented when a miner is present, the iPD system provides operators more latitude to safely position themselves around the CMM to best perform their work. The additional freedom may lead to safer, more efficient CMM operation by providing the operator and other crew members more flexibility while performing tasks near the CMM, and by preventing unintentional machine shutdowns associated with conventional proximity detection systems when a miner enters the stop zone.

Ultimately, these advantages also help to build miner acceptance of proximity detection systems. While iPD systems have not yet been implemented in commercially available proximity detection systems, the intention of the iPD design is to provide worker protection at least equivalent to conventional proximity detection while giving miners more flexibility to perform their work.

Intelligent Proximity: Zone Configurations

This article presents two iPD zone configurations. Neither is presented as a recommendation; rather, they are examples for comparing factors associated with establishing zone definitions. The first, iPD 1, is shown in Figure 4 (p. 74). Zones 1 and 2 are dynamic, meaning that they follow the position of the conveyor boom as it pivots laterally to load coal onto haulage equipment. Zones 3 through 10 are static and based on the CMM chassis (frame).

Each zone is associated with a set of CMM functions that are disabled whenever a miner is detected within that zone. The logic governing which functions are disabled is shown in Table 1 (p. 74). NIOSH researchers designed this zone layout as an example of one potential configuration for selective machine function shutdown (Carr & DuCarme, 2013; Carr, Jobs, Lutz, et al., 2015; DuCarme, Carr & Reyes, 2013; Jobs, Carr & DuCarme, 2011; Jobs, Carr & DuCarme, 2012).

Figure 4
iPD 1 Zone Configuration

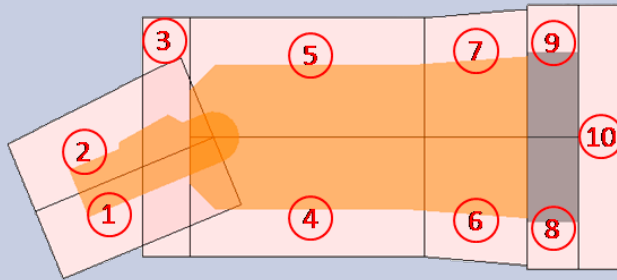

4) Zone 11 has been added to iPD 2 to account for the area that exists between Zones 1 and 2 around the conveyor boom. This prevents any unsafe conveyor boom motions when an operator is near the tail of providing a buffer between Zones 1 and 2.

5) Zones 12 and 13 have been added to iPD 2 to account for a miner being on top of the CMM.

Investigation Methodology

To gain insight into the safety potential afforded by different proximity detection zone configurations, NIOSH researchers conducted an analysis of 39 fatalities that occurred between 1984 and 2015 in which a miner was struck or pinned by a CMM in an underground U.S. mine. The objectives of this analysis were to estimate the number of cases for which a proximity detection system may have prevented the incident, and to identify the potential safety benefits of iPD systems compared to conventional systems.

MSHA fatality investigation reports were reviewed and analyzed for each incident to determine whether a conventional or iPD system could have prevented the fatality. Although it is mandated that all machine tram and conveyor boom functionality is shut down when a miner enters any stop zone around a CMM, for the purposes of this analysis it was assumed that all machine functions would be shut down on a commercial proximity detection system based on manufacturer designs. Additionally, it is assumed that iPD systems would selectively disable machine functions as previously described. In considering conventional proximity detection, it is assumed that all machine motion would

be blocked when a miner is detected in any stop zone, while iPD systems would selectively disable machine functions as previously described.

As one example, on Nov. 17, 2012, a CMM operator was pinned while backing the machine out of the first cut of a crosscut that was being developed. According to the MSHA investigation report, the operator was pinned between the left side of the cutting drum and rib (side of coal pillar; Figure 6, p. 77). Based on the fatality position as indicated in the report, the operator likely pivoted the machine, which resulted in the incident.

NIOSH analysis concluded that a conventional proximity detection system could have prevented this incident, as the machine would have shut down once the operator entered the stop zone. For both iPD 1 and iPD 2 zone configurations, the operator would have been in Zone 9; analysis further concluded that both intelligent zone configurations could have prevented the incident, as the pivoting actions would have been prevented (left tracks only reverse, or left tracks reverse and right tracks forward would have been disabled).

Table 1
iPD 1 Zone Configuration Logic

			Zone									
			1	2	3	4	5	6	7	8	9	10
			○: Allowable Action X: Disabled Action									
Machine Motion	Code		1	2	3	4	5	6	7	8	9	10
Tram (locomotion using left and/or right crawlers)	both forward	F	○	○	○	○	○	○	○	○	○	X
	right only forward	RF	X	○	○	X	○	○	X	○	X	X
	left only forward	LF	○	X	○	○	X	X	○	X	○	X
	both reverse	R	X	X	X	○	○	○	○	○	○	○
	right only reverse	RR	X	X	X	○	X	X	○	X	○	○
	left only reverse	LR	X	X	X	X	○	○	X	○	X	○
	right forward/left reverse	LP	X	○	X	X	○	○	X	○	X	X
left forward/right reverse	RP	○	X	X	○	X	X	○	X	○	X	
Conveyor	raise	CU	X	X	○	○	○	○	○	○	○	○
	lower	CD	○	○	○	○	○	○	○	○	○	○
	swing right	CR	X	○	○	○	○	○	○	○	○	○
	swing left	CL	○	X	○	○	○	○	○	○	○	○
Cutter head	raise	HU	○	○	○	○	○	○	○	X	X	X
	lower	HD	○	○	○	○	○	○	○	X	X	X
Gathering pan	raise	PU	○	○	○	○	○	○	○	X	X	X
	lower	PD	○	○	○	○	○	○	○	X	X	X
Cutter motor	H	○	○	○	○	○	○	○	X	X	X	
Conveyor motor	C	X	X	X	○	○	○	○	○	○	○	○
High speed tram			X	X	X	X	X	X	X	X	X	X

The 10 zones were created to capture all possible machine motions that could affect a given location, and to provide zone logic to allow operators to perform actions that would not put them at risk. For example, different machine actions would be disabled for a miner standing in Zone 4 compared to a miner standing in Zone 6, due to the pivot point of the machine (intersection of Zones 4-7).

The second zone configuration, iPD 2, is shown in Figure 5. Zones 1, 2, 11 and 12 are dynamic and change based on the position of the conveyor boom. Zones 3 through 10 and 13 are static and based on the CMM chassis. Table 2 describes the zone logic for iPD 2. Major differences between the two configurations include:

1) The functions blocked by Zones 1 and 2 in iPD 2 depend on the position of the conveyor swing. If the conveyor is centered (within a preset tolerance), the functions blocked are less restrictive than if the conveyor is swung either left or right.

2) Forward and reverse tram functions in iPD 2 are blocked for Zones 4 through 9 to prevent incidents when a miner is beside the CMM.

3) All tram functions in iPD 2 are blocked for Zones 6 and 7 to prevent any unsafe pivoting motions.

Figure 5
iPD 2 Zone Configuration

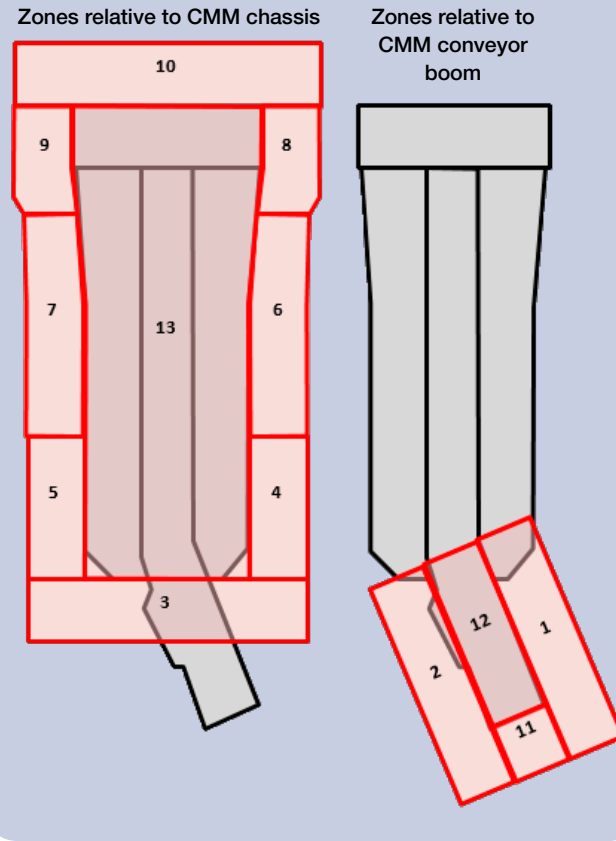

Evaluating Past Incidents to Assess Fatality Reduction Potential

The MSHA report for each of the 39 fatal incidents was evaluated to determine if conventional or either of the two iPD systems could have prevented the fatality. The most important element for each incident is the victim’s location relative to the CMM (i.e., zone). Clear, specific information is not available in the reports for all cases, therefore, for some fatalities multiple zones are identified as possible locations of the victim at the time of the incident. Similarly, all possible machine motions that may have caused the incident were identified.

Given the mandate that all machine tram and boom functionality be shut down when a miner enters a stop zone, for the purposes of this analysis it was assumed that all machine functions would be shut down on a commercial proximity detection system based on manufacturer designs. For each of the two proposed intelligent system configurations, if the associated logic would have blocked the possible hazardous machine motions identified, it is assumed that the system would have prevented the incident and the resulting fatal injury. The results of this analysis are shown in Tables 3 and 4 (pp. 76-77).

Conclusion

Operating or working with CMMs is one of the most hazardous jobs in an underground coal mine. Miners have been fatally struck or pinned by a CMM 39 times

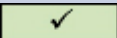

Table 2
iPD 2 Zone Configuration Logic

Machine Motion		Code		Zone														
				Tail centered		Tail left of center		Tail right of center		All tail positions								
				1	2	1	2	1	2	3	4	5	6	7	8	9	10	11
Tram	both forward	F	○	○	○	×	×	○	○	×	×	×	×	×	×	○	×	×
	right only forward	RF	×	○	×	×	×	○	×	×	×	×	×	×	×	×	×	×
	left only forward	LF	○	×	○	×	×	×	×	×	×	×	×	×	×	×	×	×
	both reverse	R	○	○	○	○	○	×	×	×	×	×	×	×	○	×	×	×
	right only reverse	RR	×	×	×	×	×	×	×	×	×	×	×	×	×	×	×	×
	left only reverse	LR	×	×	×	×	×	×	×	×	×	×	×	×	×	×	×	×
	right forward/left reverse	LP	×	○	×	×	×	×	×	○	×	×	○	×	×	×	×	×
	left forward/right reverse	RP	○	×	×	×	×	×	×	○	×	×	×	×	○	×	×	×
Conveyor	raise	CU	○	○	○	○	○	○	○	○	○	○	○	○	○	×	×	○
	lower	CD	○	○	○	○	○	○	○	○	○	○	○	○	○	×	×	○
	swing right	CR	×	○	×	○	×	○	○	○	○	○	○	○	○	×	×	○
	swing left	CL	○	×	○	×	○	×	○	○	○	○	○	○	○	×	×	○
Cutter head	raise	HU	○	○	○	○	○	○	○	○	○	○	×	×	×	○	○	×
	lower	HD	○	○	○	○	○	○	○	○	○	○	×	×	×	○	○	×
Gathering pan	raise	PU	○	○	○	○	○	○	○	○	○	○	×	×	×	○	○	×
	lower	PD	○	○	○	○	○	○	○	○	○	○	×	×	×	○	○	×
Cutter motor	H	○	○	○	○	○	○	○	○	○	○	○	×	×	×	○	○	×
Conveyor motor	C	○	○	○	○	○	○	○	○	○	○	○	○	○	○	×	×	×
High speed tram			×	×	×	×	×	×	×	×	×	×	×	×	×	×	×	×

Table 3

Comparison of Configurations

Fatality	Date (Y-M-D)	Possible Zone(s) for victim location		Machine Motion(s) that may have caused accident	Potential prevention of fatal accident		
		iPD 1	iPD 2		Conventional	iPD 1	iPD 2
1	1984-10-15	4	4	F, LF, RF	✓	X	✓
2	1988-06-22	1	1	RF, LP	✓	✓	✓
3	1988-12-12	4	4	RF, LR, LP	✓	✓	✓
4	1990-02-01	4	4	RF, LR, LP	✓	✓	✓
5	1990-03-29	4	4	F, RF, LF	✓	X	✓
6 ⁽¹⁾	1990-11-12	4, 5 (on conveyor)	13	C	X	X	X
7	1990-12-17	4	4	RF, LR, LP	✓	✓	✓
8	1991-09-25	1	1	LR, LP	✓	✓	✓
9	1992-09-02	4 (on board)	4 (on board)	R, RR, LR, LP	X	X	X
10	1993-07-19	8, 10	8, 10	F, LF, RF, RP	✓	X	✓
11 ⁽¹⁾	1993-11-05	8, 9, 10	10, 13	H	X	X	X
12	1993-12-27	1	1	RF, LR, LP	✓	✓	✓
13	1995-03-24	1	1	RF, LP	✓	✓	✓
14 ⁽¹⁾	1995-04-18	1, 2, 3 (on conveyor)	12	C	X	X	X
15	1996-10-21	4	4	LR, LP	✓	✓	✓
16	1997-03-28	5	5	LF, RR, RP	✓	✓	✓
17	1997-07-26	1	1	F, RF, LF	✓	X	✓
18	2000-01-21	8, 9, 10	10, 13	F, LF, RR, RP	✓	X	✓
19	2000-05-12	4	4	RF	✓	✓	✓
20	2000-08-15	4	4	RF, LR, LP	✓	✓	✓
21	2001-04-12	1	1	None (CMM struck by other machine)	X	X	X
22	2001-11-21	8	8	LF, RR, RP	✓	✓	✓
23	2002-03-22	1	1	RF, LR, LP	✓	✓	✓
24	2002-08-12	1	1	F, RF, LF	✓	X	✓
25	2003-04-15	5	5	LF, RR, RP	✓	✓	✓
26	2003-10-22	6, 8	8	LF, RR	✓	✓	✓
27 ⁽²⁾	2004-02-01	2	2	RP	X	X	X
28	2004-04-03	8	8	LF, RP	✓	✓	✓
29	2004-05-18	1	1	RF, LR, LP	✓	✓	✓
30 ⁽³⁾	2008-04-18	1, 2	1, 2, 11	--	X	X	X
31	2008-10-16	4	4	R, LR, LP	✓	X	✓
32	2010-04-22	2	2	F	✓	X	✓
33	2010-06-24	4	4	LP	✓	✓	✓
34	2011-03-25	1	1	RF, LR, LP	✓	✓	✓
35	2012-07-27	1	1	LR, LP	✓	✓	✓
36	2012-11-17	9	9	LR, LP	✓	✓	✓
37	2013-02-13	1	1	CR	✓	✓	✓
38	2014-02-21	1	1	LP	✓	✓	✓
39	2015-01-28	1	1	LP	✓	✓	✓

 Fatality that could have been prevented by proximity detection
 Fatality that could not have been prevented by proximity detection

Note. ⁽¹⁾Proximity detection is not likely to have been a preventive factor since the incident occurred during maintenance. These systems as designed may interfere with various maintenance tasks and are unlikely to be used. ⁽²⁾This incident occurred on a full-face CMM (cutting drum spans the entire width of an entry) with an integrated roof bolter. The bolter operator was pinned when he exited the onboard cab. A system with a silent zone (designated zone where a mine worker is allowed) may have been effective if designed for full-face CMMs. ⁽³⁾This incident occurred on a CMM with a mobile bridge conveyor system (continuous haulage). Special design considerations would be necessary to adapt proximity detection to accommodate the presence of continuous haulage equipment while still providing worker protection.

since 1984. MSHA has mandated that all CMMs (except full-faced CMMs) be equipped with commercially available proximity detection systems to improve miner safety by preventing the CMM from contacting a miner and also by providing audible and visual warnings to alert the miner when in an unsafe zone.

NIOSH researchers have developed a prototype iPD that aims to provide equivalent safety to conventional proximity detection systems while improving the operational efficiency of the system. This is accomplished by disabling only unsafe actions and allowing operators more freedom to position themselves to accomplish their work. To evaluate the safety performance of conventional and intelligent systems, the research team reviewed and analyzed the 39 fatal incidents involving CMMs.

The study results indicate that 82% of the fatalities could have been prevented by conventional systems. Two different iPD zone configurations were presented to illustrate the different factors that affect performance and both were analyzed over the same set of 39 fatal incidents. This showed that iPD 2 could have prevented 82% of the fatality cases (the same as conventional proximity), while iPD 1 could have been a preventive factor in only 62% of the incidents.

This indicates that by implementing iPD into commercially available proximity detection systems, miners could have the safety benefits of proximity detection systems while potentially having more freedom to move around the machine. They may also be able to work more efficiently, thus potentially enhancing acceptance of the systems. The results of the analyses were based on MSHA investigation reports. While sufficient incident data are not available to yield statistically validated conclusions, the analyses performed provide insight into the effectiveness of proximity detection systems.

While iPD 2 appeared to be superior to iPD 1 in this particular study, due to the iPD 1 zone logic definitions that allowed for tramming motions when a miner is detected on the side of the CMM, the comparison more importantly illustrates that zone configuration definitions are critical to proximity detection system effectiveness. Ultimately, neither iPD 1 nor iPD 2 should be considered recommended designs, but rather, examples of how the zones for an intelligent proximity detection system could be configured, and how different parameters affect the ability to prevent worker injury. It should also be noted that many other factors can influence the performance of proximity detection systems, such as conveyor elevation, cutting drum elevation, tramming and mining mode (Carr, et al., 2015). These factors should also be taken into consideration when designing zone configurations for intelligent proximity systems.

While proximity detection systems operating on the electromagnetic principle have been developed specifically for underground coal mining equipment, this technology can be applicable in various industries where other localization-based sensing technologies, such as GPS, are not feasible. Additionally, electromagnetic proximity detection could be integrated into existing systems to enhance the localization and detection capabilities of humans and machinery through sensor fusion. Possible examples include surface mining, construction sites,

Figure 6

Location of Operator Fatality

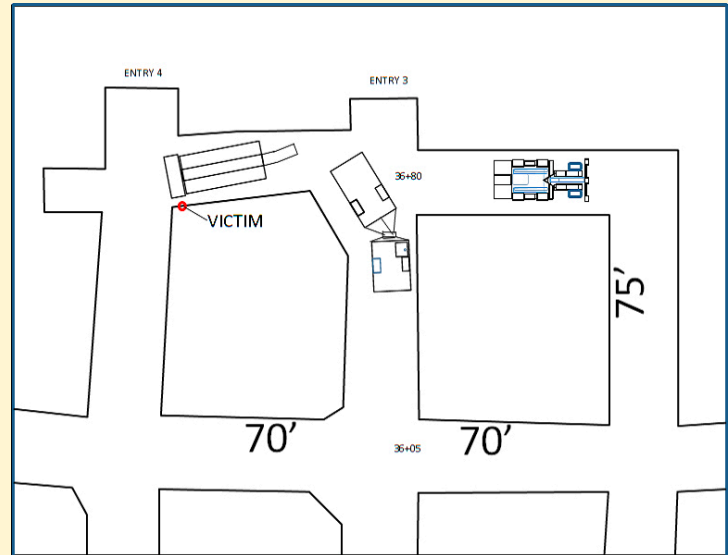

Table 4

Overall Analysis Results

	Conventional proximity	Intelligent proximity	
	NIOSH analysis	iPD 1	iPD 2
Percent of fatalities in which proximity detection was likely to have been a preventive factor	82%	62%	82%

oil and gas exploration, agriculture and crop management, warehousing and distribution, and underwater exploration. **PS**

References

Carr, J.L. & DuCarme, J.P. (2013). Performance of an intelligent proximity detection system for continuous mining machines. 2013 SME Annual Meeting, Feb. 24-27, 2013, Denver, CO.

Carr J.L., Jobes C.C., Lutz T.J., et al. (2015). Underground field tests of second-generation proximity detection systems on continuous mining machines. 2015 SME Annual Meeting, Feb. 15-18, Denver, CO, Preprint 15-081.

MSHA. (2015). Proximity detection systems for continuous mining machines in underground coal mines (30 CFR Part 75, MSHA-2010-0001). *Federal Register*, 80(10).

DuCarme, J.P., Carr, J.L. & Reyes, M.A. (2013). Smart sensing: The next generation in proximity detection. *Mining Magazine*, July/August, 58-66.

Jobes, C.C., Carr, J.L., DuCarme, J.P., et al. (2011). Determining proximity warning and action zones for a magnetic proximity detection system. 2011 IEEE Industry Applications Society Annual Meeting. doi:10.1109/ias.2011.6074392

Jobes, C.C., Carr, J.L. & DuCarme, J.P. (2012). Evaluation of an advanced proximity detection system for continuous mining machines. *International Journal of Applied Engineering Research*, 7(6), 649-671.

MSHA, District 8. (2013, June 24). Report of investigation: Underground coal mine fatal machinery accident, Nov. 17, 2012 (CAI-2012-17). Retrieved from <http://arlweb.msha.gov/FATALS/2012/ftl12c17.pdf>

MSHA. (2015). Preliminary accident reports, fatalities and fatal investigation reports. Retrieved from <http://arlweb.msha.gov/fatals>