



# Influence of Temperature on Generator Current and Magnetic Field of a Proximity Detection System

Jingcheng Li<sup>1</sup> · Adam Smith<sup>1</sup> · Jacob Carr<sup>1</sup> · Bruce Whisner<sup>1</sup>

Received: 14 January 2019 / Accepted: 25 January 2019 / Published online: 13 February 2019

© This is a U.S. government work and its text is not subject to copyright protection in the United States; however, its text may be subject to foreign copyright protection 2019

## Abstract

Electromagnetic-based proximity detection systems (PDSs) are utilized on mining machinery to protect workers from being pinned or struck. These systems generate magnetic fields covering the space around a machine, and a miner-wearable component (MWC) detects the field. The PDS determines the distance of miners relative to the machine based on the detected magnetic flux density in the magnetic field. This information is used to establish warning and shutdown zones around the machine. Maintaining a stable magnetic field is essential for system accuracy. However, components used to generate magnetic fields can be influenced by temperature changes. Depending on ventilation conditions and seasonal alternation, a PDS can be subject to significant temperature fluctuation. To better understand and quantify this phenomenon, researchers from the National Institute for Occupational Safety and Health (NIOSH) developed an experimental apparatus to study the influence of temperature on magnetic field generator circuits used in PDSs. Results from the study show that the electric current through a generator can be influenced by both ambient and internal temperatures, modifying the magnetic field that is produced. These findings show that temperature can significantly influence the ability of PDSs, used in underground coal mines, to accurately determine a worker's position in relation to mining machine.

**Keywords** Magnetic field · Magnetic distribution model · Proximity detection system · Temperature

## 1 Introduction

Electromagnetic-based proximity detection systems have been developed to reduce machine-related accidents in underground coal mines. The first proximity detection systems installed in underground coal mines were developed for continuous mining machines (CMMs). There are five of such proximity detection systems that are approved for

use in US mines by the Mine Safety and Health Administration (MSHA) [1, 2].

There are several basic components that interact within an electromagnetic proximity detection system (PDS). A PDS includes two main elements: a set of generators to create magnetic fields around a CMM and a set of magnetic probes to detect the fields. These systems can determine if a miner is located at a safe distance from the machine based on the detected magnetic flux density. Stability of the magnetic fields is essential for system accuracy.

Several disturbance factors exist that can have an adverse effect on the magnetic fields. To minimize these adverse effects, it is necessary to identify and characterize these disturbance factors. Environmental factors, such as the presence of metal, including the metal body of a machine and the steel structure of wire mesh, in the magnetic field have been studied [3, 4]. This paper describes a study of another such environmental disturbance factor, namely the influence of temperature on the ferrite-core generators used in a PDS.

Two types of temperatures can influence a generator: internal and ambient. Depending on ventilation conditions and seasonal alternations, the ambient temperature of a generator

---

✉ Jingcheng Li  
JLi16@cdc.gov

Adam Smith  
ASmith9@cdc.gov

Jacob Carr  
JCarr1@cdc.gov

Bruce Whisner  
Bwhisner@cdc.gov

<sup>1</sup> Pittsburgh Mining Research Division, National Institute for Occupational Safety and Health, 626 Cochrans Mill Road, Pittsburgh, PA 15236, USA

can be subject to wide variation. A generator is a magnetic radiation antenna with a copper wire wound around a ferrite core. Both the copper wire and the ferrite core consume electrical energy, which will generate heat, creating internal temperature change. This study investigated the effects of both internal and ambient temperature changes.

## 2 Method and Experimental Setup

In this study, the generator current and temperature of a proximity detection system were both measured and recorded. The measurements were used to determine the relationship between the current and temperature. Both continuous current and pulse-modulated current are used. Figure 1 shows a block diagram of the instrumentation used in the experiment. A National Instruments (NI) PXI 7854R module in an NI PXIe 1082 chassis generates a 73-kHz analog signal that feeds to an RF power amplifier. The amplifier provides current to the generator, which produces the magnetic field. The winding of AWG 17 copper wire for the generator has 36 turns on a ferrite core with dimensions of 190.5 mm × 25.4 mm (7.5 in. × 1 in.). A matched capacitor to the generator circuit, labeled C in Fig. 1, is connected between the amplifier and the generator. The analog current signal is measured by a current transformer probe and digitized by an NI 9223 module in the measurement unit of volts (not amperes). The measurement is then fed to a computer through a USB port. A type T thermocouple is bonded to the surface at the center of the generator to measure the temperature of the generator. The temperature signal is fed to a computer through an NI 9211 module and a USB port. All acquired data is fed to a computer for post-processing.

Temperature fluctuation can also impact the electrical properties of the capacitor, C. To minimize the influence of temperature on the capacitor, it is placed in a thermoelectric cooler—a Koolatron Thermoelectric Cooler. This keeps the capacitor environment constant at a low temperature throughout the study.

A similar cooler is also used to cool down the generator to determine the relationship between its current and constant ambient temperature.

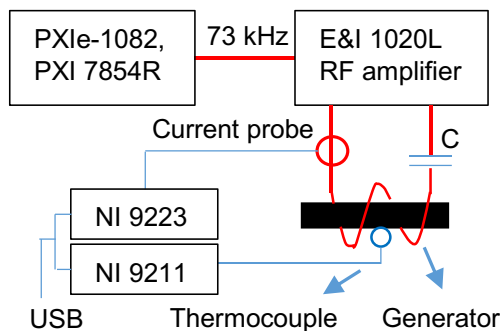

Fig. 1 Block diagram of the system instrumentation for the experiment

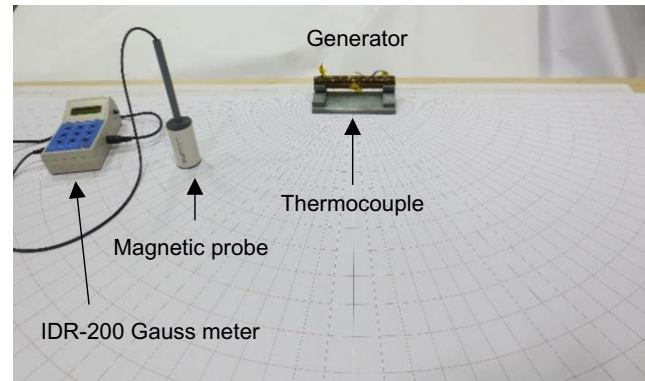

Fig. 2 Generator, gauss meter, and thermocouple used in the experiment

Figure 2 shows the actual generator used in the experiment which is positioned on an elevated wooden table approximately 1 m from the ground. The light-colored dot at the center of the generator is the thermocouple that is glued onto it. An IDR-200 Gaussmeter with its magnetic probe is also shown in the figure. A polar coordinate system is used to facilitate measurement of location coordinates of a given point in the space around the generator and of magnetic flux density at the point.

## 3 Test Results

The test results with the system running with a continuous current are presented first, followed by the test results for a pulse-modulated current. The effect on magnetic field accuracy is also presented.

The relationship between temperature and magnetic field generator current is not linear. Figure 3 shows the change in root-mean-square (RMS) current as internal temperature increases as the system was operated for a period of approximately 110 min. The generator was exposed to air with a room temperature of 79.00 °F (26.10 °C). The room temperature was measured with another thermocouple set on the table 1 m away from the generator under test. The heating that

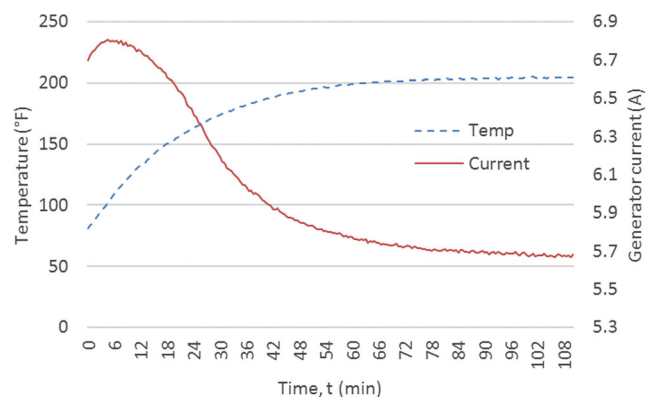
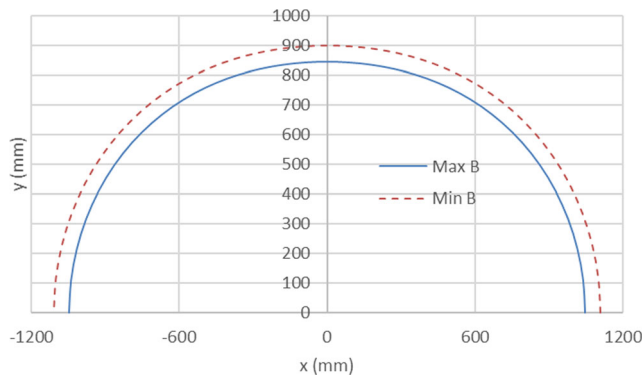

Fig. 3 Change of current with temperature for the generator running with continuous current in RMS value

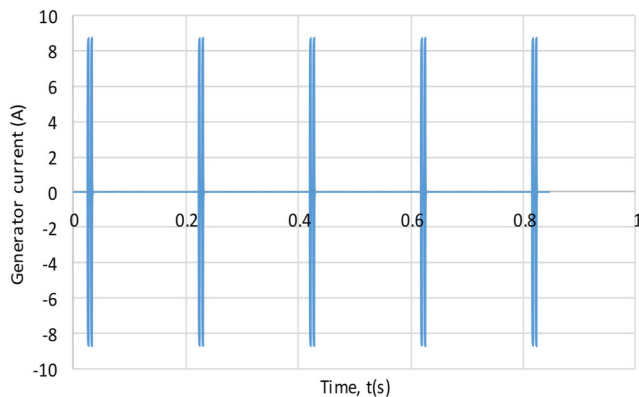

**Fig. 4** Magnetic shells with maximum and minimum magnetic flux densities,  $B$ , associated with maximum and minimum generator current

occurred during the test was entirely due to an internal temperature increase. As shown in Fig. 3, the current can change by up to 20% with a temperature change from 80.80 to 205.00 °F (27.10 to 96.10 °C).

The magnetic flux density  $B$  changes with the current. Figure 4 shows two magnetic shells. A shell is defined as all points around the generator with a given value of  $B$ . The inner shell represents the magnetic field distribution associated with the maximum current and the outer one with the minimum current observed during the test as shown in Fig. 3. The discrepancy between these two shells indicates the change in location accuracy due to the magnetic field distribution fluctuation resulting from the temperature fluctuation. As shown in Fig. 4, the location calculated at a high temperature (a low current) can be farther away from the generator than it should be, as indicated by the inner shell. The margin of calculated location errors shows in the area between these two shells.

Some proximity detection systems run with a modulated current and, in particular, use a low-frequency square wave to modulate a high-frequency current. The square wave, in this case, serves as a switch. The high-frequency current is switched on to allow it to flow through the generator when the square wave is at the high level, and the current is cut off when the square wave is at the low level. This arrangement



**Fig. 5** A series of sets of two modulated pulses with a frequency of 73 kHz for the peak-to-peak current

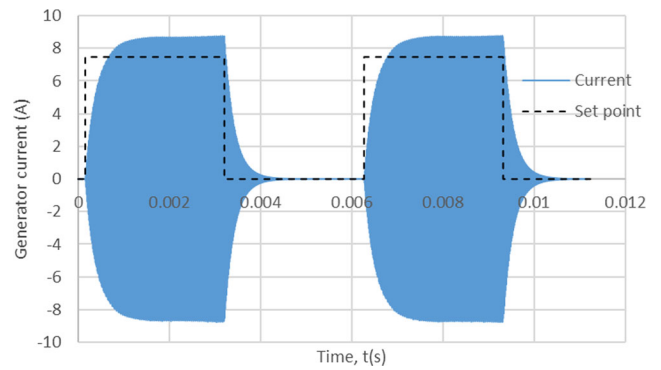
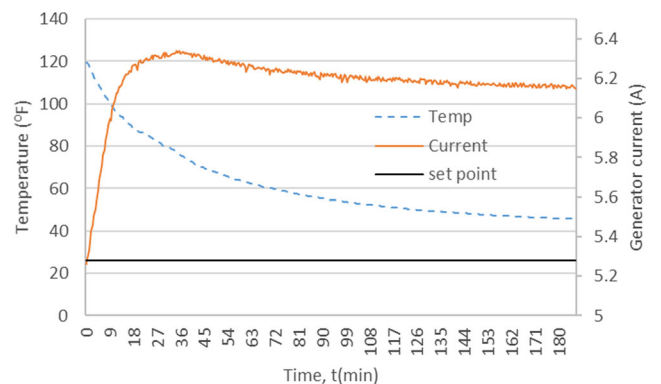

**Fig. 6** Measured 73-kHz-current waves and set points for a set of dual pulses

allows the generators of a multi-generator system to run in sequence, producing magnetic fields covering overlapping spaces with no interference. Figure 5 shows the modulated current waves (peak-to-peak) used in this study. In Fig. 5, there are five sets of the pulse-modulated current within a second. Each set consists of two individual pulses. The frequency of the current in each pulse is 73 kHz. Each pulse has a width of 0.003 s. The gap between two pulses within a set is 0.003 s.

Figure 6 gives a closer look at this pulse-modulated current for one set of two pulses. Figure 6 also shows the current set point as a dashed line, which represents the set output current positive peak value. The pulse current is apparently distorted because of the energy-storing components of the circuit, namely the system inductor and capacitor. As a result, the pulse current has a slow rising time and a slow falling time. The actual current is also noticeably higher than the set point of the current due to a lower temperature than the initial temperature at the time the current was set. It is worth noting that a distorted current wave can also cause a similar distortion of the magnetic field produced by the current. A distorted field could, in turn, result in an inaccurate field measurement reading and an inaccurate location calculation.

Figure 7 shows the relationship between the current in RMS and generator temperature after the generator was moved into a cooler with an ambient temperature of



**Fig. 7** The change of the generator current with temperature with the current initially set at 5.278 A in RMS value

46.00 °F (7.80 °C) to cool down from an initial internal temperature of 120.00 °F (48.90 °C). (The generator was uniformly pre-heated to 180.00 °F, or 82.20 °C, and after the temperature dropped to 120.00 °F, or 48.90 °C, the current output was set to 5.278 A in RMS, and measurements were started.) As shown in Fig. 7, the current increased up to 20% as the generator cooled. As the magnetic field is produced by the current, a similar proportional change occurs in the magnetic flux density. Ambient temperature fluctuation can thus cause a magnetic flux density change, which causes a fluctuation of the location calculations of the system as demonstrated in Fig. 4.

As shown in Figs. 3 and 7, both continuous and pulse-modulated generator currents can change with temperature. Also, as shown in the figures, both current types appear to follow the same trend of change. The lower the temperature is, the greater the current generally becomes, and vice versa. As shown in Fig. 3, the current changes by around 20% with a change in internal temperature of around 124.00 °F (69 °C) for the system running in continuous current mode. As shown in Fig. 7, the current also changes by around 20% with a temperature change of 74.00 °F (41.1 °C) for the system running in pulse-modulated mode although the measurements were made in a different temperature range. This suggests that the system running in the pulse-modulated mode can be more susceptible to ambient temperature change. It is understandable that a generator running with a pulse-modulated current consumes much less electrical energy to maintain its own internal temperature than one running with continuous current.

## 4 Discussion

NIOSH researchers have constructed two identical and independent laboratory proximity detection systems, and conducted the same temperature-current experiment for both systems. The test results showed a similar relationship between generator current and temperature. NIOSH researchers also conducted a number of the experiments in different temperature ranges, different days, and times for the generators on both systems. For all of these experiments, the effect of temperature on generator current remained the same.

The cause of the generator's current change with temperature is that the electrical properties of the generator change with temperature. The magnetic properties of the ferrite core change with temperature which lead inductance of the generator to change [5, 6]. The effect varies with the magnetic materials used for core. The electrical resistance of both the copper wire and the ferrite core of the generator also changes with temperature [6, 7]. The changes of both inductance and resistance will cause an impedance change of the generator causing a corresponding change in current. As a consequence, the magnetic field changes accordingly.

As illustrated in this study, the generator current reacts slowly as the internal temperature stabilizes. This suggests that system calibration procedures should account for the settling time needed for the current to stabilize. This may take several minutes to several tens of minutes. This also suggests that system calibration should take into account temperature difference between the calibration environment and the working environment. A location calculation error may result if a calibration is performed in one environment and the system runs at another environment at a very different temperature without temperature compensation. A system calibration performed on the surface, for example, could potentially cause errors in a location calculation if the working environment of the system is underground and the temperature on the surface is substantially different from that underground. This also suggests that if a proximity detection system operates alternately in a strongly ventilated area and a less strongly ventilated area, a generator could experience both internal and ambient temperature changes. If the changes are substantially large, location calculation errors may occur. If calibration is performed on-site in a working environment with a small ambient temperature fluctuation after the internal temperature of generators has been stabilized, a small fluctuation in accuracy is expected. With a system used on the surface, daily temperature variation may affect system accuracy.

As mentioned earlier, NIOSH researchers have constructed two identical laboratory proximity detection systems. To stabilize the generator current against temperature variations and other current-disturbing factors, they introduced a feedback control system to each of the systems. Tests showed that the feedback control system could effectively stabilize the generator current against both internal and ambient temperature fluctuations of the generators. Even better, the feedback system could also be able to correct the distortions of the pulsed current for the generators as shown in Fig. 6.

## 5 Limitations

Because the internal temperature is influenced by the ambient temperature and vice versa, it is difficult to perform an analysis of the influence of one while completely isolating it from the other. This paper provides only one of the ways to study their influence on proximity detection systems.

Observations show that temperature has a similar effect on the matched capacitor, though this paper focuses on an analysis of the influence of temperature on the generator only. A temperature fluctuation can lead to changes of the capacitance and resistance of the capacitor. These changes would be expected to be small, depending on the temperature change and the quality of capacitor. Because the capacitor is part of the generator circuit, it will also affect the generator current. The combined effect of temperature on both generator and

capacitor could be greater for generator current than just for the generator alone.

The experiments in this study show that the generator current can be susceptible to temperature changes. The tests also show that susceptibilities vary with generators. This suggests that it is a challenge to develop a manual compensation strategy to compensate for the temperature susceptibilities of proximity detection systems. An automated feedback control system can be used to account for the variations of the temperature susceptibilities of the generators. A stabilized and controllable generator current is essential to having stabilized system performance.

## 6 Conclusions

This study identifies one influential factor—the temperature both internal and ambient on generator current of a proximity detection system, and the magnetic field produced by the current. The measurements show that the generator current can change with temperature, which results in a corresponding magnetic flux density distribution change that can cause a location calculation error as given in the area between two shells in Fig. 4 if the temperature change is not compensated. The occurrence of an error and size of the error depends on the range of temperature change and the susceptibility of the generator to temperature. In general, the greater the temperature range, the larger the error will be. The measurements also show that current has a slow response to a temperature change. This suggests that waiting until the temperature of a generator has stabilized before starting a system calibration could reduce a system error. This also suggests that it is necessary to develop an automated control system to stabilize the generator current against temperature fluctuation. Stabilized current is essential to ensuring a stabilized magnetic field, which is, in turn, critical to ensuring accurate location calculation from the system. Integration of these findings into system design by PDS manufacturers will result in improved performance that can save lives and make mines safer.

**Acknowledgments** The authors sincerely thank Mr. Jeffrey A. Yonkey and Mr. Joseph DuCarme for their support in designing and conducting this study.

## Compliance with Ethical Standards

**Conflict of Interest** The authors declare that there is no conflict of interest.

**Disclaimer** The findings and conclusions in this report are those of the author(s) and do not necessarily represent the views of the National Institute for Occupational Safety and Health. Reference to specific brand names does not imply endorsement by the National Institute for Occupational Safety and Health.

**Publisher's Note** Springer Nature remains neutral with regard to jurisdictional claims in published maps and institutional affiliations.

## References

1. Mine Safety and Health Administration (2013) Approval & Certification Center, Proximity Detection Systems, <https://arlweb.msha.gov/TECHSUPP/ACC/lists/18Prox.pdf>. 2013
2. Mine Safety and Health Administration (2015) Department of Labor, Proximity Detection Systems for Continuous Mining Machines in Underground Coal Mines. Federal Register Vol. 80, No. 10. 30 CFR Part 75, MSHA-2010-0001
3. Li J, Carr JL, Waynert JA, Kovalchik PG (2013) Environmental impact on the magnetic field distribution of a magnetic proximity detection system in an underground coal mine. *Journal of Electromagnetic Waves and Applications (JEWA)* 27(18):2416–2429(14)
4. Li J, DuCarme J, Reyes M, Smith A (2017) “Investigation of influence of a large steel plate on the magnetic field distribution of a proximity detection system,” presented at SME Annual Meeting, Denver, CO, Feb 18–22. 2017
5. Goldman A (2002) “Handbook of modern ferromagnetic materials,” Second Printing, Kluwer Academic Publishers Group, 101 Philip Drive, Assinippi Park, Norwell, MA 02061, pp. 66–67, 605–606. 2002
6. Magnetics, Inc. (n.d.) “Designing with magnetic cores at high temperatures,” <https://www.mag-inc.com/design/design-guides/designing-with-magnetic-cores-at-high-temperatures>
7. Kuphaldt TR (n.d.) Chapter 12 – physics of conductors and insulators in lessons in electric circuits, vol. 1, <https://www.allaboutcircuits.com/textbook/direct-current/chpt-12/temperature-coefficient-resistance/>