

## Preprint 03-065

### MEASUREMENT OF AIRFLOW IN A SIMULATED UNDERGROUND MINE ENVIRONMENT USING AN ULTRASONIC ANEMOMETER

C. D. Taylor  
R. J. Timko  
M. J. Senk  
A. Lusin

Natl Inst for Occupatnl Sfty & Health  
Pittsburgh, PA

#### ABSTRACT

Federal regulations require that methane liberated at the face be diluted and removed to maintain methane gas concentrations below 1 pct (CFR) in working places and intake air courses. The delivery and distribution of intake air at the face is critical for effective face ventilation. Improved techniques for monitoring the movement of intake air to the face are needed.

A test system was developed and a computer program written for using a three-axis ultrasonic anemometer to measure airflow in a simulated mine entry. Results of tests conducted in the entry showed that the anemometer is a valuable tool for measuring mine airflow conditions near the face.

#### BACKGROUND

The highest methane concentrations in coalmines are usually found near faces of entries where coal is being mined. To maintain methane concentration below 1 pct an adequate quantity of intake air must be supplied to the face. A rotating vane anemometer is routinely used to measure air speed at the end of the curtain or tubing. A pitot tube with a manometer can be used to measure velocity pressure, which can then be applied to a mathematical formula and converted to air speed. The quantity of intake air reaching the entry is calculated by multiplying the average air speed by the cross-sectional area of the tubing or curtain. Past studies have shown that these flow quantities may not be good estimates of how much air actually reaches the face (Thimons et al., 1999).

Better estimates of face airflow could be made if the velocities were measured closer to the face. However, it is difficult to get accurate readings of air velocities in by the tubing or brattice because the direction and magnitude of the flow are constantly changing in this area. Instruments such as the vane anemometer measure average speed in only one direction. Unless the anemometer is properly aligned with the direction of the airflow, the resultant air speed values will not be accurate.

Ultrasonic anemometers have been designed for measuring airflow velocities in three-dimensional space. With a three-axis

anemometer, orientation of the instrument with flow direction is not necessary to measure speed. The anemometer can also record rapid changes in velocity. The instrument used for this research had a sampling rate of 40 Hz, and sample data was reported at 1 Hz.

The ultrasonic anemometer has been used to map large scale flow patterns in enclosed rooms and has provided quantitative information concerning the amount of air movement and variations in flow (Yost et al., 1992).

The objective of this work is to determine if a three-axis ultrasonic anemometer could be used to evaluate airflow movement in a test facility where underground mining conditions were simulated. The paper describes the development and use of a protocol for collecting and analyzing data obtained with the anemometer.

#### TEST CONDITIONS

##### Surface Test Facility

Tests were conducted in the NIOSH Pittsburgh Research Laboratory's Ventilation Test Gallery (Figure 1). One side of the gallery was designed to simulate a mining entry with a 2.2 m (7-ft) high roof and ribs 5 m (16-1/2 ft) apart. For half of the tests the entry

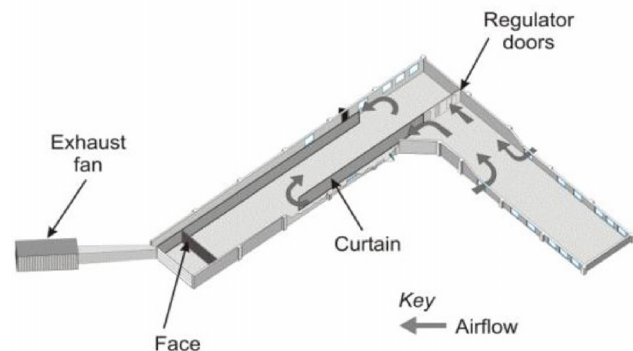

Figure 1. Ventilation Test Gallery



Figure 2. Three-axis ultrasonic anemometer

width was reduced to 4 m (13 ft) by building a wall 1 m (3 1/2 ft) from the right rib.

An exhaust fan draws approximately 5.9 m<sup>3</sup>/s (12,500 cfm) of air from the gallery. To simulate air flow in an underground mine, air was directed toward the entry face using a 2.2 m (7 ft) high brattice curtain that was supported by a wood frame constructed 0.6 m (2 ft) from the left side of the entry. The end of the blowing curtain was 10.7 m (35 ft) back from the face for all tests. Airflow between the curtain and the rib (2.8 or 4.7 m<sup>3</sup>/s, 6,000 or 10,000 cfm) was adjusted by opening or shutting regulator doors. The average air speed at the end of the blowing curtain was measured with a vane anemometer by performing a moving vertical traverse of the cross-sectional area.

## EQUIPMENT

### Three-Axis Anemometer

Air speed and direction measurements were made using a three-axis ultrasonic anemometer manufactured by the Gill Instruments, Ltd, Great Britain (References to specific products does not imply endorsement by NIOSH) (Figure 2).

The operation of this device is based on the principle that the speed of a sound pressure wave varies with the local air speed. The anemometer has a linear response and an absolute calibration that depends only on sensor spacing and transit time accuracy.

The anemometer uses sound pulses to determine the air-velocity vector, which is resolved into the three directional components (U, V and W). These orthogonal components correspond to flow toward and away from the face (U direction), right and left across the entry (V direction) and up and down (W direction).

An overhead two-dimensional traversing system was used to support the anemometer as it was moved to each sampling locations (Figure 3). The overhead system included a 0.6-m (2-ft) wide garage door panel that was attached to two roof-mounted rails. A 3.7-m (12-ft) long panel was used in the 4-m (13-ft entry) and a 4.6-m (15-ft) long panel in the 5-m (16 1/2 ft) entry. A 4-wheel trolley moved along a rail that was attached to the front edge of each panel. A round aluminum rod, 25-mm (1 inch) in diameter by 0.4-m (14-in) long, was connected to the bottom of the trolley. A specially designed bracket was used to attach the anemometer to the aluminum rod. The anemometer could be rotated or moved vertically in the bracket. The anemometer was inverted with the sensor head positioned 1.1 m (3.5 ft) from the floor

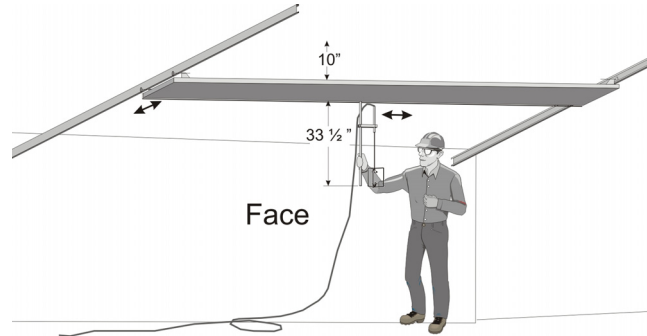

Figure 3. Support system for moving anemometer

and roof. All measurements were made at this elevation.

An arrow that was printed on one end of the sensor head was used to indicate the reference direction. The anemometer was rotated in the bracket until the arrow was pointed toward the face. All direction readings were made with respect to the arrow orientation (Figure 4). For example, with the arrow directed toward the face, flow toward the face was reported as 180 degrees and flow away from the face was reported as 360 degrees. The angle in degrees that describes the direction of flow increases in a clockwise direction as viewed from above the instrument.

Four vertical lines, corresponding to the sampling distances from the left side of the entry (see Figure 5) were placed on the face. With the printed arrow directed toward the face, a beam from a laser, mounted on the anemometer bracket, was aligned with each of the lines. The alignment of the beam was checked during testing to assure that the anemometer had not rotated in the bracket.

## SAMPLING PROCEDURE

A 4 x 9 grid of sampling locations was used. Flow measurements were made for two entry widths, 4 and 5 m (13 and 16 1/2-ft), and two intake flows, 2.8 and 4.7 m<sup>3</sup>/s (6,000 and 10,000 cfm). A repeat test was performed for each operating condition and results averaged for each location sampled (Figure 5).

The overhead traversing system was used to manually move the anemometer from one location to the next. The instrument was positioned at each location by aligning it with the distances marked on the door panel rails and on the front of the door panel. After

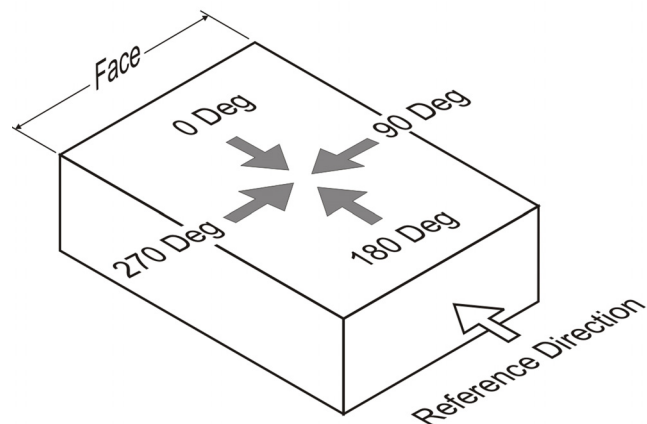

Figure 4. Reference angle directions in degrees

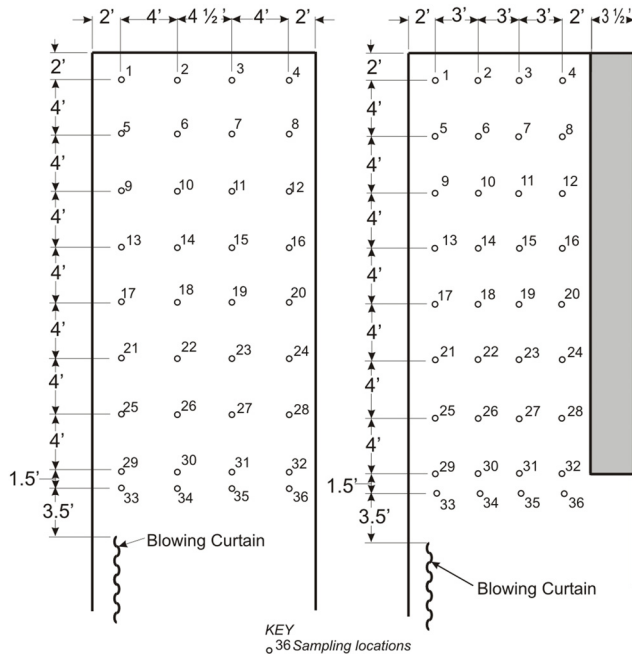

Figure 5. Measurement locations in gallery

positioning the instrument, all personnel left the gallery to avoid disturbing the airflow patterns during testing. Data was collected and recorded for three minutes.

The three-minute sampling period (180 samples) was chosen to provide average flow magnitude and direction readings that would include the expected range of values. After data collection was completed in each row, the anemometer was moved either toward or away from the face to the next row where measurements had not been made.

#### DATA ACQUISITION

The anemometer was attached to a Power Communication Interface (PCI) box that provided power and collected signals from the anemometer. The anemometer was configured using software (ANEMCOM, Version 3.04) provided by the manufacturer. The configuration settings used during these tests are given in Table 1.

A software program written and developed by NIOSH personnel, ANEMVENT 2002, facilitated the acquisition and analysis of data obtained with the ultrasonic anemometer. More information about the program is available in the software instruction manual.

The ANEMVENT 2002 program creates an EXCEL data spreadsheet for storing U, V, and W velocity components generated by the anemometer. When configured in the UVW Polled mode (see Table 1) one set of U, V, and W velocity components is recorded each

Table 1. - Configuration and Tabular Options using Windmaster Anemometer

Output mode	ASCII, UVW, polled
Output units	m/s
Measurement average	Off
Sample period	1 Hz (1 sample per second)
Baud rate	36,400
Parity	8 Data, No parity

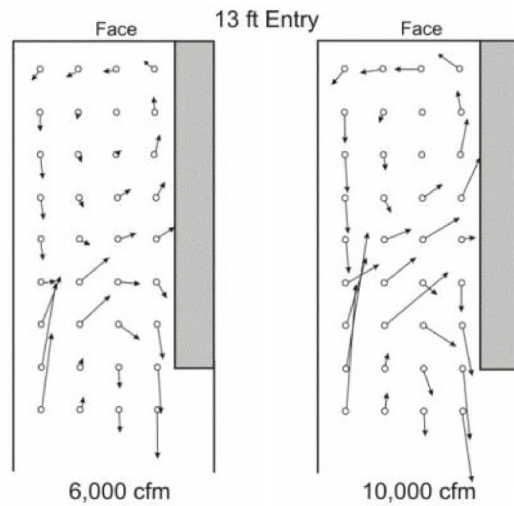

Figure 6 Flow profiles in 13ft entry

second when the PCI is queried by the software program. The average value for each U, V, and W component is calculated for every three-minute sampling period. The flow angle and magnitude for the flow direction in the horizontal plane are calculated using the average U and V values. The direction and speed data are transferred to a second EXCEL spreadsheet that uses algorithms and EXCEL functions to create a chart containing vector lines that illustrate flow at each location sampled.

#### RESULTS, DISCUSSION AND FUTURE RESEARCH

##### Qualitative Flow Profiles

The flow profiles in Figures 6 and 7 are drawings adapted from vector lines created with the EXCEL charts. For each location, the direction of the line indicates flow direction, and the length of the line

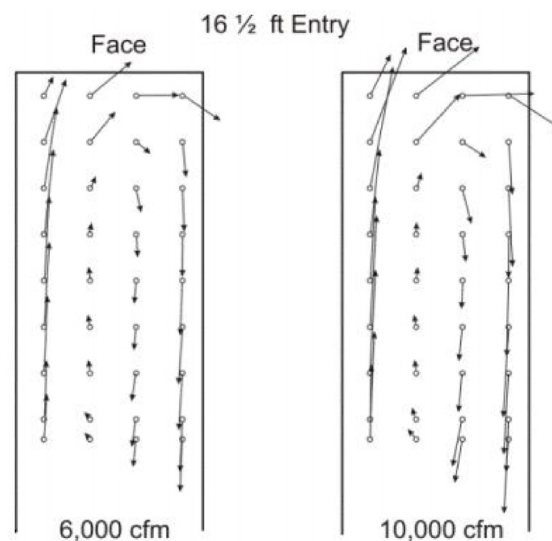

Figure 7. Flow profiles in 16-1/2 ft entry

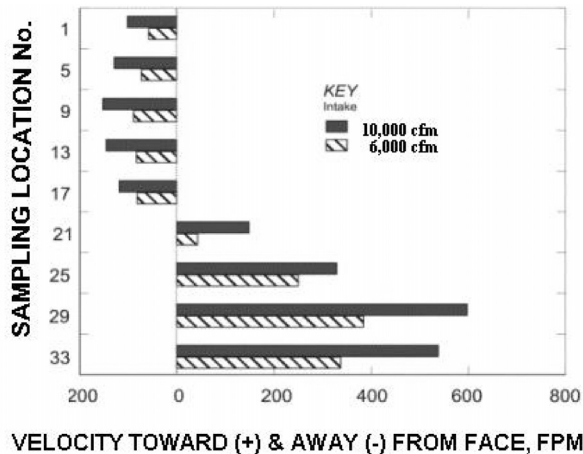

Figure 8. Air speed toward face in 13 ft entry, 2 ft from the left side

is proportional to the magnitude.

A comparison of the profiles provided two specific results. First, increasing the intake flow quantity from 2.8 to 4.7 m<sup>3</sup>/s (6,000 cfm to 10,000) cfm increased air velocities for both entry widths but did not significantly change the direction of flow.

Second, airflow directions in the 4- and 5- m (13 and 16 1/2-ft) entries were significantly different. In the 4-m (13-ft) wide entry the flow profile formed a pattern approximating the shape of a "figure 8." Air moved from the curtain along the left rib for about 4-m (13-ft) before turning right, flowing toward the right rib, and paralleling the right rib to the face. Air moved from right to left across the face, back toward the curtain along the left rib before turning again to the right rib. Airflow in the 5-m (16 1/2-ft) entry traveled in a simpler pattern. It moved from the curtain up the left rib to the face, left to right across the face and back along the right rib.

**QUANTITATIVE FLOW, U AND V COMPONENTS**

The U and V components of the airflow were used to compare velocity profiles for air moving toward and parallel to the face. The U values were measured at sampling locations 0.6-m (2-ft) from the left rib and the V values at locations 0.6-m (2-ft) from the face. Air velocity measurements in the U direction are shown in Figures 8 and 9. Figures 10 and 11 show flow velocities in the V direction.

The velocities in the U and V directions varied for different entry widths and intake quantities. As expected, velocities measured in the U and V directions increased when the intake air quantity was

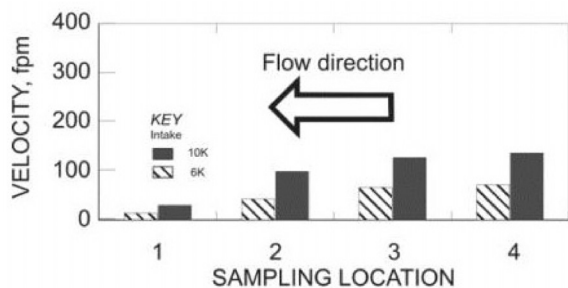

Figure 10. Air speed across face in 13 ft entry, 2 ft from face

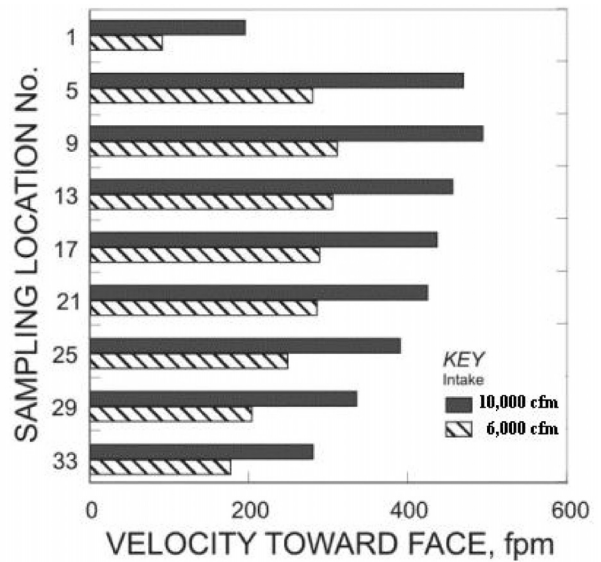

Figure 9. Air speed toward face in 16-1/2 ft entry, 2 ft from the left side

increased from 2.8 to 4.7 m<sup>3</sup>/s (6,000 to 10,000 cfm). In the 4-m (13-ft) wide entry the reversal in velocity in the U direction was the result of the figure 8 flow pattern (Figure 9). In the 5-m (16 1/2-ft) entry velocity readings in the U direction generally increased as the air moved toward the face.

For the same intake quantity, velocities across the face were higher in the 16 1/2-ft entry. Air velocities increased as the air moved across the 5-m (16 1/2-ft) face and decreased across the 4-m (13-ft) face.

**QUANTITATIVE FLOW, TURBULENCE**

The flow profiles described above were drawn using time averaged velocity and direction data. The individual (one second) readings for flow direction and speed were plotted versus time to show how much the readings varied during each 3-minute test. The scatter plots in Figure 12 show how the direction readings varied at two adjacent locations (21 and 22) in the 5-m (16 1/2 ft) entry when the intake flow was 4.7 m<sup>3</sup>/s (10,000 cfm). The average flow direction at both locations was approximately 180 degrees (i.e. toward the face), but the flow direction varied much more at location 22. Scatter plots showing the changes in speed with time are shown in Figure 13. Airspeed varied much more at location 21 where the average magnitude was much higher.

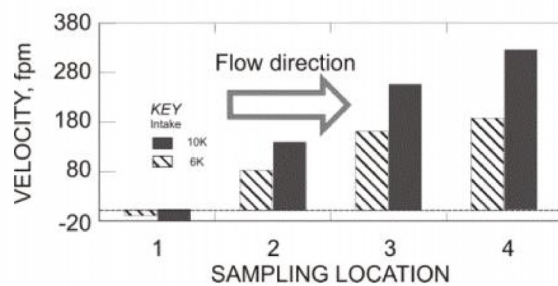

Figure 11. Air speed across face in 16-1/2 ft entry, 2 ft from face

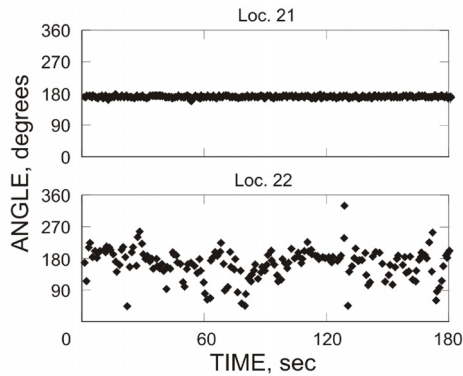

Figure 12. Flow direction at two locations

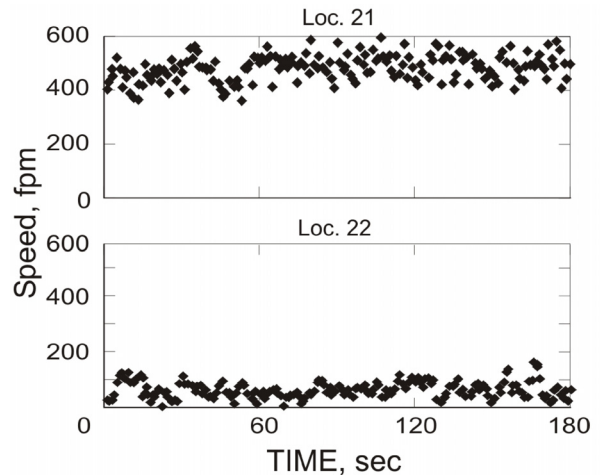

Figure 13. Speed measurements at two locations

### FUTURE RESEARCH

To measure airflow at a simulated mining face, researchers adapted a three-axis ultrasonic anemometer and developed a computer program. The ultrasonic anemometer provided airflow information that could not be obtained with instruments normally used for measuring airflow, such as a vane-type anemometer. The resulting data showed how entry geometry and intake flow quantities affected airflow profiles.

To simplify the flow patterns this study was conducted with an empty entry. During future studies airflow measurement will be taken with equipment, such as a model-mining machine, at the face. Tests with the model-mining machine will include the operation of machine-mounted sprays and a simulated scrubber. Past research has shown that the machine-mounted water sprays and scrubber have a large effect on methane dilution at the face. The three-axis anemometer will be used to characterize how airflow at the face is affected by spray and scrubber operation.

Practical considerations of test time and available equipment limited the number of sampling locations to 36. The locations were evenly distributed throughout the test area. When drawing the flow profiles it was assumed that the flow patterns remained uniform between sampling locations, especially between locations near the center of the entry. However, it is more difficult to estimate flow speeds and directions between the sampling locations and the face or ribs.

Differences in velocity profiles between 2 and 1 ft of the left rib of the entry were noted using measurements taken with a vane anemometer. For a 5-m (16 1/2 ft) entry with an air quantity of 4.7 m<sup>3</sup>/s (10,000 cfm), velocity measurements were taken 0.6 and 0.3 m

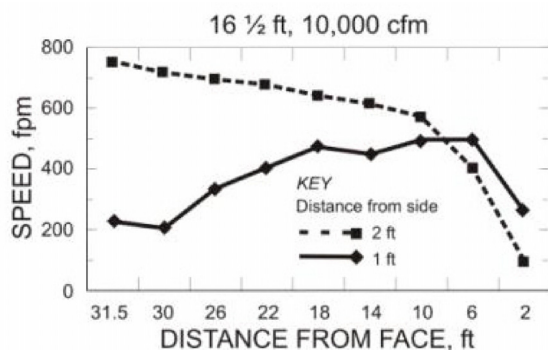

Figure 14. Speeds 2 ft and 1 ft from the left rib

(2 ft and 1 ft) from the left rib with a hand-held vane anemometer. Figure 14 shows that, while velocities 0.3 m (1 ft) from the left rib decreased as one moved away from the curtain, velocities measured 0.6 m (2 ft) from the left rib tended to increase while moving toward the face from the curtain. A similar increase in velocity was seen with the ultrasonic measurements. Additional locations will be sampled closer to the entry face and ribs with the three-axis anemometer to better identify differences in speed and direction in these border areas.

Measurements will also be taken at different heights in the gallery. No vertical velocity profiling took place during these tests since all data were collected in a single plane, midway between the floor and roof. The W (vertical) component of flow was measured, and, although always smaller than the U and V components, it varied in magnitude and direction. Measurements in multiple vertical planes will provide data for plotting flow in the UV (horizontal) and UW (vertical) planes.

As part of a cooperative study with the University of Kentucky Department of Mining Engineering, data obtained in these studies will be compared with the results from small-scale airflow studies, which used Particle Imaging Velocimetry (PIV) to measure airflow patterns (Wala, et. al., 2002). If there is good correlation between the full-scale and small-scale study flow measurements, PIV data may provide the information needed to interpolate air speed and direction data in areas not sampled during the gallery studies.

The flow velocity and flow direction measurements made with the ultrasonic anemometer was constantly changing during the three minutes that data were collected. The amount these readings varied depended on the sampling location and the test operating conditions. The flow direction and speed data collected each second were plotted versus the test elapsed time to compare the relative variation in readings. The variation in the velocity readings can be related to the flow turbulence. Flow turbulence will be calculated during future tests and its impact on methane dilution and removal will be evaluated.

During future studies, a three-axis anemometer will be used to evaluate the effects of other factors, such as exhaust ventilation and curtain setback distance, on face air direction and speed. For the same operating conditions, methane will be released at the face of the mining entry and methane concentrations measured at the same locations used to measure airflow. The airflow and methane profiles will be compared to determine the relationship between the airflow and methane concentrations.

#### REFERENCES

- Code of Federal Regulations (CFR-30) 75.323, (b)(ii).
- Thimons, E. D., Taylor, C. D., Zimmer, J. A., 1999, "Evaluating the Ventilation of a 40-Foot Two-Pass Extended Cut," NIOSH Report of Investigations (RI 9648).
- Yost, M.G., and Spear, R.C., 1992, " Measuring Indoor Airflow Patterns by Using a Sonic Vector Anemometer, American Industrial Hygienist Association Journal, Vol. 53, November, pp. 677-680.
- Wala, A., Tuner, D., and Jacob, J, 2002, "Experimental Study for Mine Face Ventilation System for Validation of Numerical Models," Proceedings of the North American/Ninth U.S. Mine Ventilation Symposium, pp. 191-196.