

CRYOGENIC SLURRY METHOD TO EXTINGUISH WASTE BANK FIRES¹

Ann G. Kim and Andrew M. Kociban²

Abstract. The U. S. Bureau of Mines (USBM) has developed a cryogenic heat transfer method to extinguish waste bank fires, which features an injected slurry of liquid N₂ and granular CO₂. The heat-absorbing character of the cryogenic slurry is due to its low temperature (-180° C), and to changes in state from the solid or liquid to the gas phase. The phase change also produces a 500-fold increase in volume, creating a cold pressure wave that moves radially from the injection point. The cold wave absorbs heat, produces an inert atmosphere, and forces smoke and fumes from the combustion zone to the surface. Thus, the injected slurry causes a relatively quick cooling of the burning material, while the expansion of the evaporating gas maintains the cool atmosphere for an extended period. The movement of the inert gas is controlled by pressure and buoyancy. In injection and heat transfer tests, the slurry was effective at lowering the temperature of an enclosed bed of burning coal to below -100° C. Low temperatures were maintained for 1 month. The USBM is currently planning a full-scale test to control a waste bank fire with the cryogenic slurry. Preliminary estimates indicate that the cost of injecting a cryogenic slurry is comparable to the cost of more conventional control methods for abandoned mine land (AML) fires. The cryogenic slurry may be also applicable to extinguishing fires in abandoned mines and to other subsurface fires.

Introduction

Waste bank fires on abandoned mined land negatively affect safety and environmental quality in many communities in coal-mining States. A survey conducted in 1968 (McNay 1971) listed 292 waste bank fires in 13 States, affecting over 1,200 ha. For 1988, the Office of Surface Mining Reclamation and Enforcement (OSM) listed 225 surface fires (table 1) on the AML Inventory (OSMRE 1989). These affected an area of over 405 ha and had an estimated reclamation cost of \$42 million. The average estimated cost to control a waste bank fire was over \$200,000 in the eastern United States and less than \$100,000 in the west.

In the past, mining companies dumped waste in any convenient area within or near the mine property. Subsequent abandonment of the mine and development of nearby real estate have placed many of these waste banks in populated urban or suburban areas. Waste bank fires, often caused by indiscriminate dumping of trash or by spontaneous combustion, are sources of noxious odors and toxic fumes. The subsurface combustion of the waste can also cause surface subsidence. These AML fires degrade the environment, can create human health problems, and can depress the value of nearby property, frequently affecting a much larger area than the waste bank.

At present, there are few effective methods for extinguishing such fires at a reasonable cost. Excavation was used in 80% of waste bank fire control projects between 1970 and 1990 (Kim and Chaiken 1993). The minimum cost per project was less than \$10,000, while the maximum was over \$1 million. At least 25% of the excavation projects were unsuccessful. Excavation is both expensive and hazardous. It requires men and equipment to work in close proximity to a fire, exposing them to a potentially dangerous environment. Excavation requires moving large amounts of hot material, large areas to spread and quench the material, and an area to dispose of the cooled material. It also exposes hot material to an essentially unlimited supply of oxygen and can propagate the fire. The failure of excavation projects is usually due either to not removing all the burning material or to replacing material that has not completely cooled.

¹Paper presented at The International Land Reclamation and Mine Drainage Conference and the Third International Conference on Abatement of Acidic Drainage, Pittsburgh, PA, April 24-29, 1994.

²Ann G. Kim, Supervisory Research Chemist, Andrew M. Kociban, Physical Science Technician, U.S. Department of Interior, Bureau of Mines, Pittsburgh, PA 15236.

Surface sealing with incombustible material is frequently used as a control technique because of its relatively low cost. Although surface seals suppress evidence of combustion, they do not extinguish fires. The surface seal is intended to exclude oxygen, limiting the rate of combustion. However, waste bank fires usually smolder and can continue to propagate with as little as 2% oxygen. Therefore, the air present in the bank at the time of sealing can support a fire for a relatively long period of time. The seal must be maintained so that no additional oxygen is introduced while the heated material cools below the reignition point. A conservative estimate of this time period is 20 yr. Since sealing does not address the problem of removing heat, unless properly constructed and well maintained, surface seals fail within 1 to 3 yr after construction.

The use of heat removal methods to extinguish waste bank fires requires delivering a heat transfer medium to the combustion zone and then removing the heated medium. The use of an extinguishing agent like water has not been routinely successful because of problems with controlling its distribution (Dalverny 1988, McNay 1971). When water is introduced into a subsurface fire, either by injection or by surface infiltration, it usually does not saturate the combustion zone and is therefore ineffective in controlling the fire.

The movement of a liquid through a nonhomogeneous porous bed (i.e., an abandoned mine or waste bank) is controlled by gravity. A liquid extinguishing agent moves downward through the larger branches of a nonuniform fracture network with little lateral dispersion; erosion makes the branches larger, causing more of the liquid to flow through the same restricted volume. The same constraints apply to surface application of a liquid extinguishing agent. Uniform distribution of a liquid through the combustion volume is the primary problem in using any liquid as a heat transfer agent.

Ideally, a fire control method for waste banks would be remotely emplaced, thus reducing the exposure of men and equipment to potential danger; would be effective in a relatively short period of time; would involve the use of a heat transfer agent that would move equilaterally from a centralized point; and would be at least no more expensive than conventional methods. Water-based liquid extinguishing agents, no matter how they are applied, normally do not satisfy these criteria.

However, a cryogenic liquid or liquefied gas, such as nitrogen or carbon dioxide, is a potentially efficient heat transfer medium. Because of the extremely low temperature of cryogenic liquids, they absorb large quantities of heat. Changes in state from the solid or liquid to the gas phase also absorb heat and produce a

Table 1. Surface fires on abandoned mine lands, 1988.

State or Tribe	Surface fires	Cost, \$K
Alabama	14	601
Colorado	9	173
Iowa	1	97
Illinois	2	260
Indiana	3	833
Kansas	2	400
Kentucky	43	5,698
Missouri	6	474
Montana	23	2,589
Navajo	3	320
New Mexico . .	4	686
North Dakota	1	NA
Ohio	4	280
Pennsylvania .	33	11,963
Tennessee . . .	2	5
Utah	9	731
Virginia	10	838
Washington . .	1	10
West Virginia .	48	16,351
Wyoming	7	138
Total	225	42,447

NA Not available.

600-fold increase in the volume of the material. The expansion of the gas from the point of injection produces uniform distribution of the heat-absorbing gas, forces hot combustion gases out of the pile, and also displaces oxygen (fig. 1).

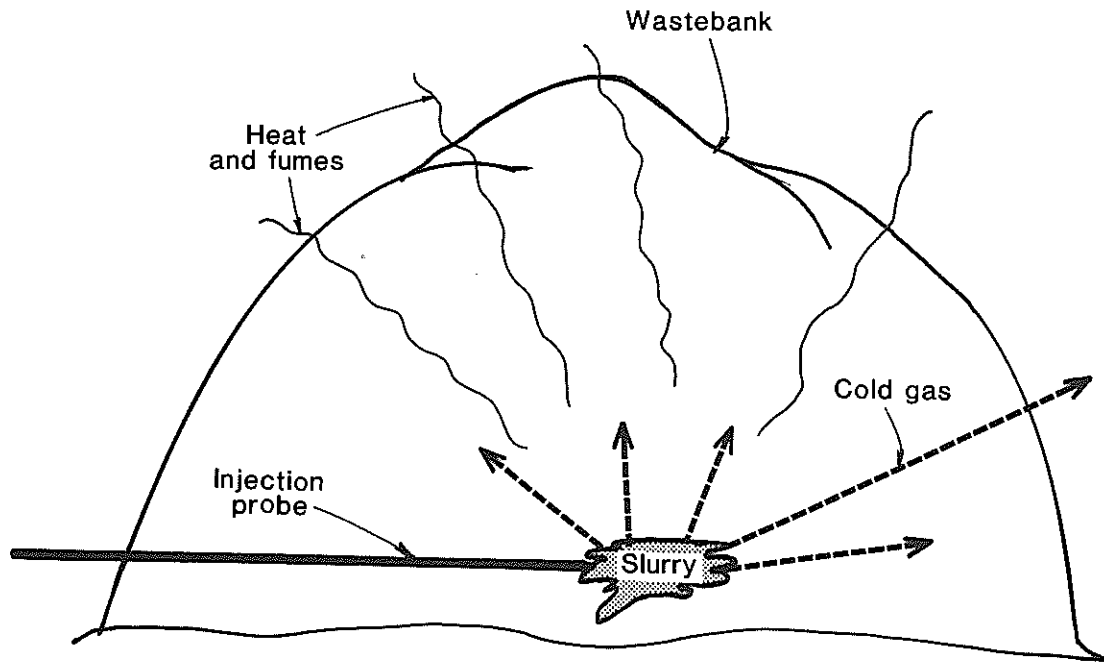

Figure 1. Schematic of heat removal related to cryogenic slurry injection.

Despite its theoretical advantages, the injection of cryogenic liquids as a heat removal technique for controlling subsurface fires has not been investigated. The injection of cryogenic N_2 has been used to control fires in active mines, but in such cases, the gas is warmed and vaporized before injection, and the control of combustion is based on oxygen exclusion. In AML fires, the smoldering combustion and the amount of stored heat, as well as the physical characteristics of waste banks or abandoned mines, limit the effectiveness of oxygen exclusion as a fire control method. The injection of a cryogenic liquid or very cold gas, however, has the advantages of heat removal capacity and uniform distribution of the extinguishing agent. Cryogenic injection is also theoretically superior with respect to safety, effectiveness, and efficiency, and it appears to be comparable in cost to other methods of extinguishing AML fires.

Experimental Work

To determine the limiting parameters and operating conditions for cryogenic injection as a method of extinguishing waste bank fires, the USBM conducted a series of small-, medium- and large-scale tests. In the initial small-scale tests, a 200-L drum was filled with approximately 310 kg of coal waste. The injection point was in the middle of the drum, and thermocouples were positioned at the same level and above and below it.

In the first test, CO_2 was obtained from a standard cylinder, in which it existed as a liquid at a temperature of $21^\circ C$ and a pressure of 58 kg/cm^2 . When the liquid flowed from the cylinder, evaporative cooling caused the temperature of the CO_2 to drop to $-78.5^\circ C$. As the pressure dropped, the liquid CO_2 was converted to a solid. In the small-scale test, the drop in pressure at the injection point caused the liquid CO_2 to solidify immediately. The formation of this CO_2 snowball blocked the point of injection and limited the distribution of the cold CO_2 .

Ten tests were conducted using liquid nitrogen, injected at a temperature of -196°C . The initial tests with liquid nitrogen showed better distribution than with CO_2 , but indicated high heat transfer losses in the delivery lines. With a modified injection nozzle (perforated sides and a closed end) and insulated (standard pipe insulation) lines, the distribution was improved and more rapid cooling was achieved. In all tests, the effect of injection on other thermocouples was observed within minutes and temperatures below 0°C were sustained for approximately 12 hr. For three tests, the refuse material in the barrel was moistened, and the injected liquid nitrogen apparently floated on the interstitial water, enhancing the lateral movement of the nitrogen.

Medium-scale tests of liquid nitrogen injection were conducted in a 4.5 m^3 box constructed of steel grate and filled with coal waste. Thermocouples were inserted into the bed of coal waste 0.3, 0.6, and 1 m below the surface. The injection point was at the horizontal and vertical midpoint of the waste bed. These tests indicated that if the refuse was wet, the formation of ice during cryogenic injection could contain and direct the flow of the liquid nitrogen. However, at any point where the refuse was dry, the liquid nitrogen would act like a liquid and flow to the bottom of the box. It was noted that as the liquid nitrogen evaporated, the expanding gas acted like a piston, forcing warm air out of the porous bed.

The USBM's Surface Trench Burn Facility was used for large-scale tests. It is a refractory-lined concrete structure, 2 m by 2 m by 6 m, that can hold approximately 40,000 kg of coal or coal waste. Temperature profiles from an array of 63 thermocouples (fig. 2) were used to characterize the liquid distribution and cooling efficiency.

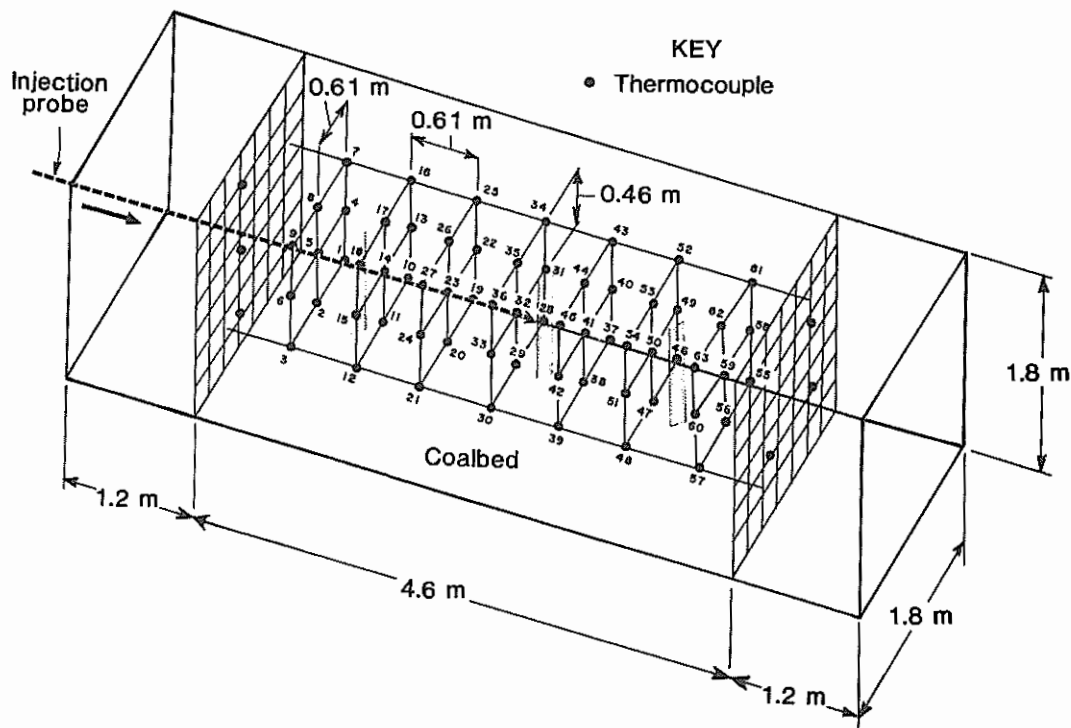

Figure 2. Diagram of thermocouple array in Surface Trench Burn Facility. Coal, 12,700 kg, run-of-mine high-volatile bituminous; volume, 15 m^3 .

In the first test in the Surface Trench Burn Facility, liquid nitrogen (5,000 kg) was injected into the center of the coal at the rate of 950 L/h. Prior to injection, the maximum temperature of the coal was approximately 100°C (fig. 3). Within a few minutes of the start of injection, the temperature near the injection

point was -68°C . In one-half hour, the temperature of half of the trench was less than 0°C . When injection was completed, approximately one third of the bed was at -170°C . After 12 days, the temperature in the trench ranged between -60° and 5°C . It was approximately 8 weeks before the temperature at all stations in the trench was above 0°C .

To improve the distribution of the heat transfer medium, tests were conducted on producing and injecting a slurry of solid CO_2 in liquid nitrogen (table 2). As noted in earlier tests, CO_2 exists in a liquid state only when it is under pressure. When the pressure is released, the CO_2 solidifies. By producing a granular CO_2 snow and combining it with liquid nitrogen, a pumpable slurry is obtained (Chaiken et al. 1991). Deposition of the solid CO_2 partially inhibits the downdip movement of the cryogenic liquid.

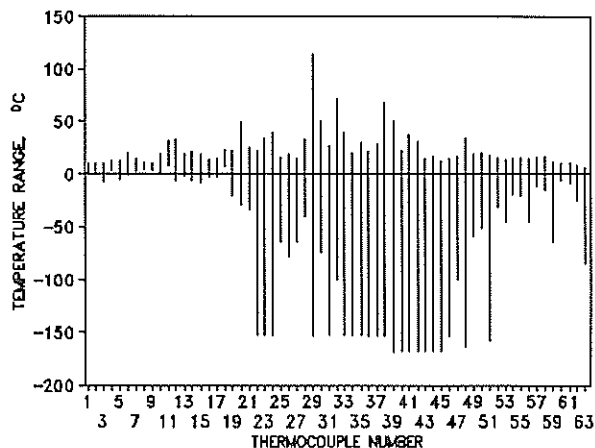

Figure 3. High and low temperatures measured during liquid nitrogen injection in Surface Trench Burn Facility .

Table 2. Physical properties of cryogenic fluids.

	Nitrogen (N_2)	Carbon dioxide (CO_2)	Slurry, 50/50 by weight
Molecular weight g/mole. .	28	44	36
Boiling point $^{\circ}\text{C}$. .	-196	-78	-180
Heat capacity, solid or liquid cal/g/ $^{\circ}\text{C}$. .	0.475	0.5	NAp
Heat capacity, gas cal/g/ $^{\circ}\text{C}$. .	0.25	0.20	NAp
Heat of vaporization cal/g. .	48	136	NAp
-dH _f cal/g. .	98	190	138
Specific volume, liquid or solid cm^3/g . .	1.25	0.66	1.04
Specific volume, gas cm^3/g . .	800	509	622

NAp Not applicable.

A prototype apparatus to produce the CO_2 snow and combine it with liquid nitrogen has been designed and assembled (fig. 4). Liquid or gaseous CO_2 is pumped through a bell shaped-nozzle; the rapid expansion forms finely powdered CO_2 particles. At the same time, liquid N_2 is injected into the nozzle to cool the CO_2 to the temperature of the nitrogen, approximately -196°C . The liquid nitrogen and solid CO_2 form a slurry in the mixing tank. A vent in the mixing tank releases the pressure caused by the vaporizing gases. The slurry flows by gravity from the mixing tank to a holding tank. Another stream of liquid nitrogen flows through a jet

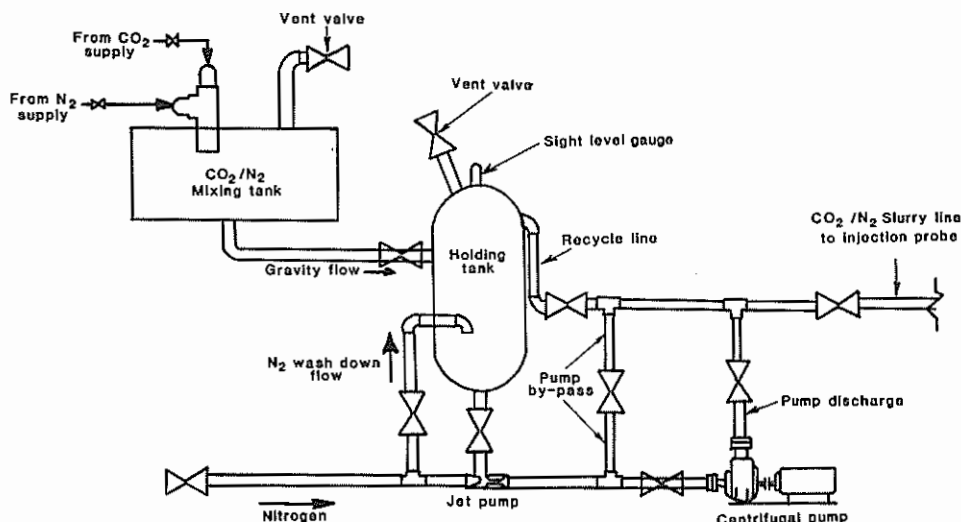

Figure 4. Prototype apparatus for making and injecting cryogenic slurry.

pump, entraining the slurry from the holding tank and carrying it through the injection line³. The injection line ends in a pointed injection probe (fig. 5) with 0.24- and 0.64-cm holes around the circumference. When the slurry of liquid N₂ and solid CO₂ is pumped into a bed of coal or coal waste, the nitrogen vaporizes and the carbon dioxide sublimates. The temperature near the probe drops to -180° C, and the expanding cold gas lowers the temperature in the surrounding volume.

Two tests of slurry injection in the Surface Trench Burn Facility were conducted. In the first test, the apparatus was cooled with liquid nitrogen, then operated in a batchwise, alternating mode. The slurry was produced in one tank, then this portion of the system was isolated and the nitrogen vapor pressure was used to force the slurry through the delivery lines into the bed of coal particles. Six batches, of approximately 100 L each, were injected. At the end of the injection phase, the remaining liquid nitrogen was injected to completely cool the bed of coal. During injection, increasing the CO₂ content of the slurry increased the probability that the delivery lines would become plugged. Slight warming and nitrogen pressure were used to clear the lines. Maintaining sufficient liquid N₂ in the slurry and eliminating sharp bends in the delivery lines minimized this problem.

During the second injection test at the trench, again using an alternating system of making the slurry in one tank while injecting it from the other, ten 100-L batches of the cryogenic slurry were injected. Fires had been started at several locations in the top third of the bed. Prior to injection, the temperature in parts of the bed exceeded 400° C (fig. 6). One day after injection, temperatures in the bed ranged from 100° to -180° C. One week after injection, 25% of the bed was still below 0° C, and after 1 month, the average temperature was 5° C (fig. 7). The variations in temperature observed at two thermocouples, TC 54 in the top of the bed and TC 56 in the bottom of the bed, indicate the effect of the movement of hot combustion gases over time and

³The original design included a cryogenic pump. However, it did not function effectively and was bypassed in all tests.

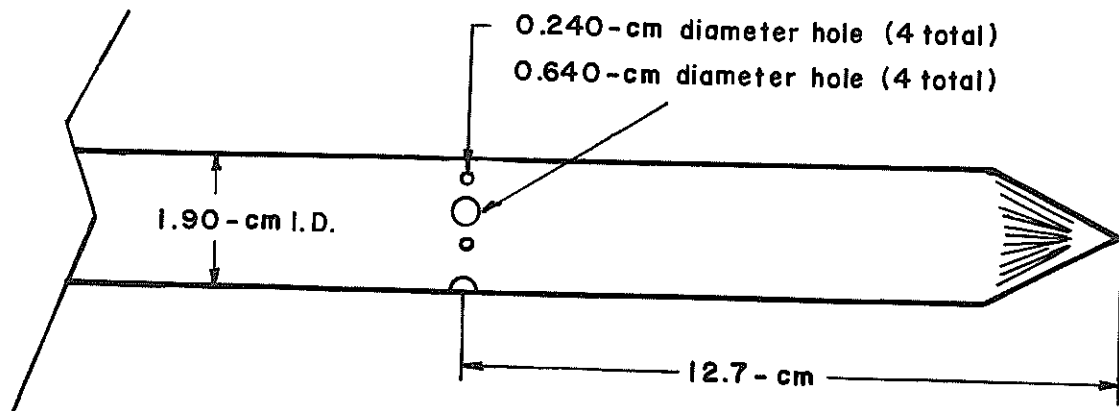

Figure 5. Injection probe for cryogenic injection.

the insulating properties of the coal. Temperatures at both thermocouples were relatively high after 1 week, but at the end of a month they were below the 100° C reignition point.

The tests in the Surface Trench Burn Facility indicated that the injection of cryogenic slurry is an efficient heat transfer method for remote fire control. The expansion of the cold gas produces a cold wave that forces heated air and gaseous combustion products out of a porous bed, displaces O₂, and lowers the temperature of the material below the reignition point.

Potential Applications

To evaluate the application of the technique to potential sites, the amount of cryogenic slurry needed to extinguish fires was estimated for two waste banks and an underground mine. The first consideration was the amount of material and the total heat content. A map or survey of the site was used to estimate its volume and temperature distribution. Based on the total heat capacity (-dH₁) of the slurry and the heat content of the site, amounts of cryogenic fluids with a comparable heat content were calculated.

In a typical waste bank fire, less than 5% of the material may be actively burning at any given time. Some of the material will be heated by the fire, and some will be at or near normal temperatures. To extinguish the fire, it is necessary to stop combustion and to remove stored heat. The heat content is a function of the mass of material, its heat capacity, and the temperature distribution.

The first site evaluated was a bituminous coal waste bank. The bank was approximately 70 m long, 30 m across at its widest point, and a maximum of 12 m high (table 3). It was a valley fill with an approximately oval cross section. The waste bank had an estimated volume of 19,600 m³ (700,000 ft³), and contained 35 x 10⁶ kg (38,500 st) of coal refuse. At this bank, although there was visual evidence of extensive combustion, data on the temperature distribution at depth were not available. For purposes of estimating the heat content, it was assumed that the average temperature of material in the bank is 20° C above normal. The heat capacity of bituminous coal refuse is 0.4 cal/g/° C. On this basis, the bank has a heat content of 1.8x 10⁸ kcal. The cryogenic slurry of liquid nitrogen and solid CO₂ has an estimated heat removal capacity of 138 kcal/kg. Approximately 1.4 million kg of slurry would be needed to remove the stored heat.

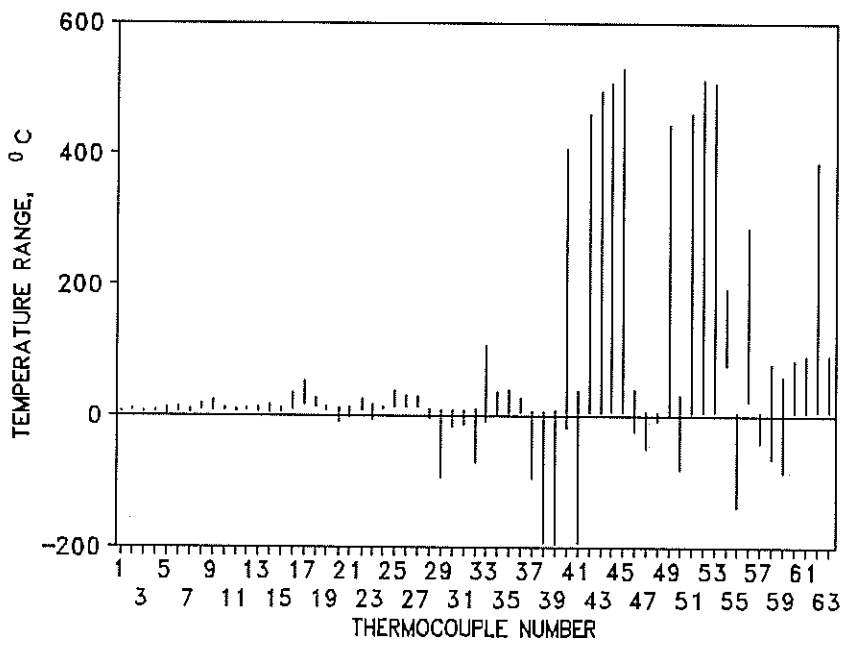

Figure 6. High and low temperatures measured during injection of cryogenic slurry (Test No. 2) in Surface Trench Burn Facility.

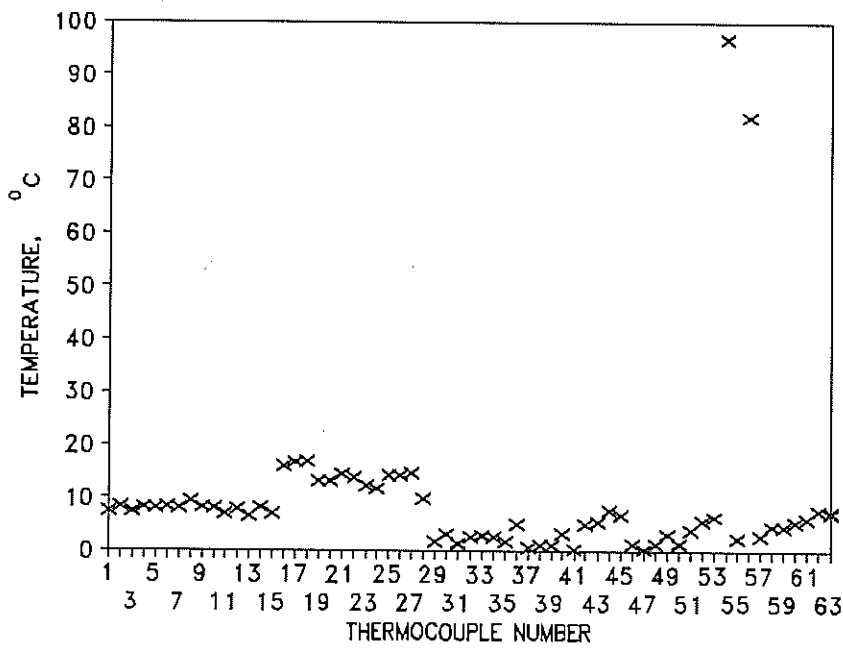

Figure 7. Thermocouple temperatures 1 month after slurry injection (Test No.2) in Surface Trench Burn Facility.

Table 3. Estimated slurry requirements for fire extinguishment

	Bituminous waste bank	Anthracite waste bank	Underground mine
Volume m ³ . .	19,600	2,250	428,000
Mass 10 ⁶ kg. .	35	2.9	830
Total heat content . . 10 ⁶ kcal. .	180	84	1,200
Slurry equivalent 10 ⁶ kg. .	1.4	0.6	8.7

At an anthracite waste bank, a topographic survey and a temperature survey were used to estimate the material requirements for cryogenic injection. This bank was in the form of a truncated cone and had a volume of 2,250 m³. With a density of 1.6 g/cm³ and a porosity of 20%, the bank contains 2.9 x 10⁶ kg of anthracite waste. At this site, a temperature survey was conducted by inserting 15-m sections of 1-cm stainless steel tubing horizontally into the bank. Temperatures, measured as a function of distance from the surface, ranged from 19° to 850° C. Treating the measured temperatures as a normal distribution, it was estimated that 70% of the bank was below 100° C, 17% was between 100° and 300° C, 4% between 300° and 500° C, and less than 9% was above 500° C. These values were integrated to estimate a total heat content of 84 x 10⁶ kcal, equivalent to 600,000 kg of cryogenic slurry.

In the underground mine scenario, both the volume of material in the mine and the overlying rock were considered. Temperature data were available for both materials. Considering 2.4 m of coal and 15 m of overlying shale, the heated volume contained 830 x 10⁶ kg. The temperature distribution indicated that 97% of the coal was at or below 100° C; the remaining 3% had an average temperature between 100° and 300° C. The temperature of the heated rock was 10° to 25° C above normal. The total heat content was 1.2 x 10⁹ kcal, the equivalent of 8.7 x 10⁶ kg of cryogenic slurry.

A cryogenic slurry injection project could be implemented in three phases. The first phase would include the acquisition of data about the site. These data would be used in determining the amount of cryogenic materials needed, in designing the injection manifold, and in establishing an injection schedule. The second phase would be a small-scale test of the injection equipment. The purpose of this test would be to verify the design parameters and to check for unforeseen problems. The third phase would be the full-scale slurry injection to extinguish the fire. Assuming no unforeseen or major delays, this type of project could be completed within 6 months to 1 yr. Although the example given here is hypothetical, the bank dimensions and the projected costs are considered to be typical of AML waste bank fires.

In tests at the USBM, smoke and hot gases were observed being forced from the burning pile. The expansion of the inert gas may displace volatile combustion products and might also produce a low oxygen environment in the immediate vicinity of the waste bank. The low temperature of the expanding gas appears to minimize the combustion odor problem, but appropriate safety equipment should be available in case of deteriorating ambient air quality.

Conclusion

The work the USBM has performed to date indicates that the use of a cryogenic slurry of liquid nitrogen and solid carbon dioxide may be a significant improvement in the methods of extinguishing AML waste bank fires. The slurry can be produced with relatively simple equipment and injected with a jet pump. The expansion of the cold gas absorbs heat and displaces air and combustion gases. Cryogenic injection should be safer and more effective than conventional methods of controlling AML fires and would appear to be no more expensive to implement.

Literature Cited

- Chaiken, R. F., E. F. Divers, A. G. Kim, and L. E. Dalverny. 1984. Calamity Hollow Mine Fire Project (in Five Parts). 4. Quenching the Fire Zone. BuMines RI 8863, 18 p.
- Chaiken, R.F., A.G. Kim, A.M. Kociban, and J.P. Slivon, Jr. Cryogenic Slurry for Extinguishing Underground Mine Fires. U.S. Patent Application, December 6, 1991.
- Dalverny, L. E. and R. F. Chaiken. 1991. Mine Fire Diagnostics and Implementation of Water Injection with Fume Exhaustion at Renton, PA. BuMines RI 9363, 42 p.
- Dalverny, L. E. 1988. Heat Removal Methods for Control of Underground Abandoned Coal Mine Fires. BuMines IC 9184, p. 343-347.
- Kim, A.G. and R.F. Chaiken. 1993. Fires in Abandoned Coal Mines and Waste Banks. BuMines IC9352, 58 p.
- Kim, A.G. 1992. Cryogenic Extinguishment of Waste Bank Fires. p. 276-289. In Proceedings of the 14th Annual Abandoned Mined Land Conference. (Chicago, IL, Aug 23-27, 1992).
- McNay, L.M. 1971. Coal Refuse Fires, An Environmental Hazard. BuMines IC 8513. 50 p.
- U.S. Office of Surface Mining, Reclamation and Enforcement. 1989. A National Inventory of Abandoned Mine Land Problems, Division of Abandoned Mined Land Reclamation.