

POST-ACCIDENT MINE COMMUNICATIONS AND TRACKING SYSTEMS

Thomas Novak, *Fellow, IEEE*, David P. Snyder, *Member, IEEE*, and
Jeffery L. Kohler, *Senior Member, IEEE*

The National Institute for Occupational Safety and Health, Office of Mine Safety and Health
PO Box 18070
Pittsburgh, PA 15236

Abstract—Recent mine disasters in the United States exposed various inadequacies and gaps in mine-safety technology. Congress responded to these tragedies by enacting the Mine Improvement and New Emergency Response Act of 2006 (MINER Act), which resulted in the most significant change to mine-safety laws in 30 years. To help meet the requirements of the MINER Act and to help eliminate future tragedies, the National Institute for Occupational Safety and Health (NIOSH) initiated aggressive research programs for developing new, and enhancing existing, mine-safety technologies. A major research emphasis addressed the lack of post-accident communications, which surfaced as a critical deficiency in some disasters. As a result, three communications approaches emerged as viable technologies – enhanced leaky-feeder, wireless-mesh, and medium-frequency systems. This paper describes the operation, application, advantages, and disadvantages of each system, as well as the challenges associated with underground wireless communications.

Index Terms—Mine communications, mine disasters.

I. INTRODUCTION

On June 15, 2006, the President signed into law the Mine Improvement and New Emergency Response Act [1], commonly known as the MINER Act. The Act was created in response to a cluster of mine tragedies that occurred in early 2006 at the Sago, Alma No. 1, and Darby No. 1 mines. This legislation amended the Coal Mine Health and Safety Act of 1977, resulting in significant changes to U.S. mining laws. A portion of the Act charged the National Institute for Occupational Safety and Health (NIOSH) with developing and improving mine-safety technologies while expediting their commercialization and implementation.

The MINER Act prominently identified the need for wireless, post-accident communications and electronic tracking systems. The Act requires each coal mine to submit an emergency response plan, which includes post-accident communications and tracking, to the Mine Safety and Health Administration (MSHA) within three years of the enactment date. Post-disaster investigations indicated that

reliable post-accident communications may have saved many lives through improved escape and rescue procedures.

In 2006, no MSHA-approved communications and tracking systems that met the intent of the MINER Act were commercially available [2]. As a result, NIOSH established a comprehensive research program to develop new, and enhance existing, communications technologies for post-accident applications in underground coal mines. Unfortunately, an underground coal mine provides an extremely difficult environment for applying traditional wireless communications.

The active areas of a mine consist of a labyrinth of tunnels imbedded in a tabular coal seam. Intersecting tunnels, referred to as *entries* and *crosscuts*, are arranged in a grid fashion and commonly extend for miles in various directions. Coal-seam thickness usually dictates the tunnel height, which can be less than three feet, but rarely more than eight feet, while the width of the tunnels typically ranges from 16 to 20 ft. The tunnels follow coal-seam undulations, resulting in limited line-of-sight distances along entries. Furthermore, the communications systems must be designed and installed to maximize their survivability after a catastrophic event, such as an explosion, fire, major roof fall, or water inundation. The survivability of the required infrastructure, therefore, must rely on system redundancy and component hardening. A catastrophic event may also compromise a mine's ventilation control devices, allowing accumulations of dangerous methane concentrations. Thus, post-accident communications systems must meet MSHA's *permissibility* requirements. To be approved as *permissible*, an electrical system must be intrinsically safe; otherwise, components must be housed in MSHA-approved, explosion-proof (XP) enclosures [3]. In either case, the system must be incapable of igniting a surrounding, explosive mixture of methane and air. This additional constraint imposes further restrictions on practical designs.

Three types of communications technologies have demonstrated potential for meeting the requirements envisioned by the MINER Act – enhanced leaky-feeder, wireless-mesh, and medium-frequency systems. Each system possesses unique advantages and disadvantages, and because underground coal mines vary considerably in size and layout,

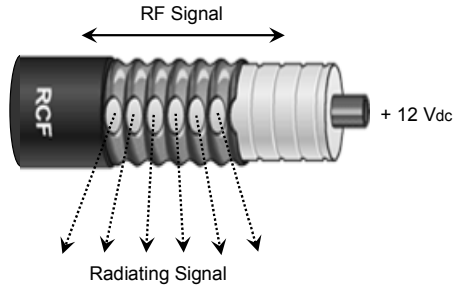

Fig. 1. Leak-feeder cable.

more than one type of system may be needed to meet the communications requirements for a given mine. The operation and application of each system are discussed below. (It should be noted that a through-the-earth communications system is being developed and has significant potential for post-accident applications; but, at the time of writing, it is not yet ready for commercialization. Therefore, this type of system will not be discussed.)

II. ENHANCED LEAKY-FEEDER SYSTEM

Because of the time constraint imposed by the MINER Act, NIOSH investigated existing and demonstrated technologies that could be modified, enhanced, and applied to post-accident communications. The leaky-feeder system has a long history of success in tunnel applications [4], and it has been used in some coal mines for routine communications since the 1980s. Its feeder cable acts as both a transmission link and a distributed antenna. The coaxial-type cable is designed to radiate, or *leak*, a portion of its transmission signal through holes in its surrounding metallic shield, as illustrated in Fig 1. Therefore, radio signals are permitted to enter and exit the cable, providing two-way communications along its entire length. The cable's center conductor conveniently supplies a dc voltage to power the system's in-line amplifiers.

While most existing leaky-feeder systems operate in the VHF band (30–300 MHz), the enhanced system operates around 450 MHz, within the UHF band (300–3000 MHz). This higher frequency allows wider bandwidths that, in turn, permit the transmission of more data at higher rates. Also, UHF signals demonstrate better free-space propagation characteristics (through crosscuts and around the corners of coal pillars) [5]. As a tradeoff, the higher frequency requires more expensive feeder cable and causes greater line attenuation and coupling losses.

A. Basic Operation

UHF signals propagate very poorly in coal or its surrounding strata; thus, signal transmission is confined to mine openings (entries and crosscuts). Therefore, leaky-feeder cable must be strung throughout a mine wherever

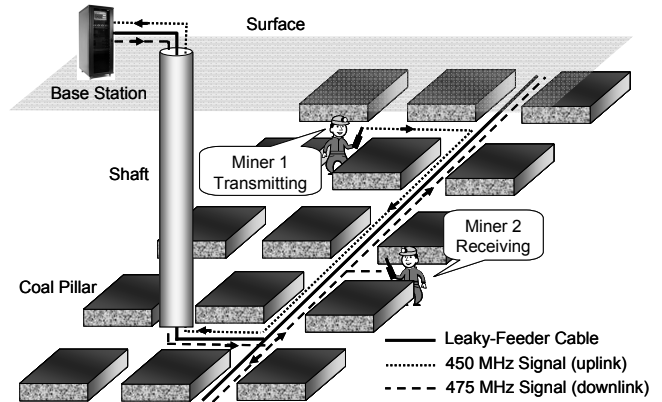

Fig. 2. Basic operation of the enhanced leaky-feeder system.

access to communications is required. Fig. 2 illustrates the basic operation of the system. The head end of the feeder cable connects to a base station located at a control center on the surface. Non-radiating coaxial cable typically connects the base station to the mine's leaky feeder, which is installed along a mine entry in Fig. 2. The base station controls the flow of communications within the mine. Fig. 2 shows Miner 1 transmitting from a radio handset. An analog format with frequency modulation (FM) is presently used for voice communications, with separate transmit and receive frequencies to allow duplex communications. For example, the signal from Miner 1's handset is transmitted at 450 MHz. At this frequency, a signal is only amplified in the *upstream* direction towards the cable's head end. A frequency-translation repeater, within the base station, receives the 450 MHz signal and retransmits it back onto the leaky feeder at 475 MHz. In-line amplifiers along the feeder amplify this retransmitted signal only in a *downstream* direction away from the head end. Miner 2, along with any other miner on the same channel within proximity of the leaky feeder, will receive Miner 1's transmission.

Sixteen channels are available on the enhanced leaky-feeder system. For routine communications, separate channels can be used for individual job functions, such as by maintenance and construction crews. Using separate channels reduces communications traffic and its associated bottlenecks. In the event of an emergency, however, the system is capable of paging all channels simultaneously.

B. System Arrangement

Fig. 3 presents a general arrangement of the enhanced leaky-feeder system. For permissibility purposes, the system is sectioned off into *cells* that are separated by *barriers*. A barrier allows radio signals to pass through the feeder cable but blocks dc power from transferring between cells. Thus, all amplifiers in a given cell are powered from a single power supply dedicated to that cell. The *injection points* allow a dc voltage from the power supply to be imposed on the center

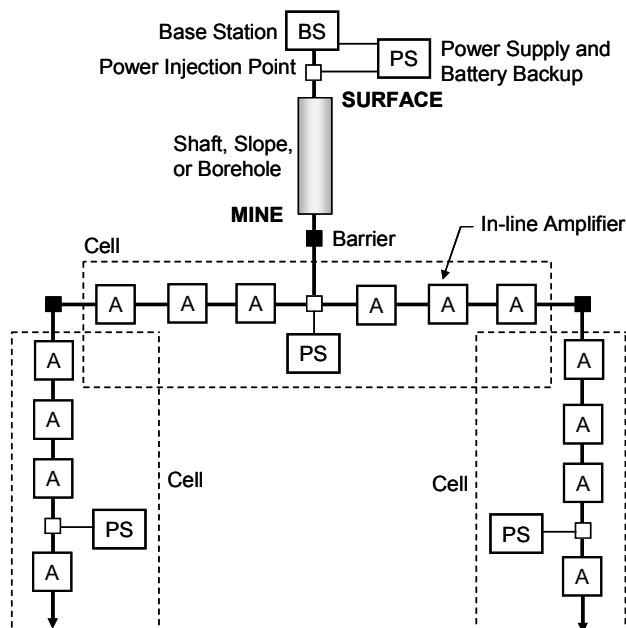

Fig. 3. General arrangement of a leaky-feeder system.

conductor of the leaky-feeder cable. Since the system must operate after a catastrophic event, each power supply requires a battery backup. Lead-acid batteries are used for this application. The batteries and their associated charging equipment are housed in an MSHA-approved, explosion-proof enclosure within each cell location. All other communications components are approved as intrinsically safe. A typical spacing between adjacent power supplies is 5000 ft.

Bidirectional, in-line amplifiers with automatic gain control are used to overcome line losses in the leaky-feeder cable, as shown in Fig. 3. The amplifiers are typically spaced at intervals of 1000 ft. At present, an auto-reversing, MSHA-approved amplifier is not yet available. Instead, as previously mentioned, existing amplifiers boost *transmit frequencies* for all channels in one direction and their associated *receive frequencies* in the opposite direction.

C. Extended Coverage

Reliable communications coverage for a leaky-feeder system is limited to the mine entry in which the feeder cable is located, plus short distances in perpendicular crosscuts with some propagation around coal pillars. The enhanced system, however, allows expanded coverage but requires additional infrastructure. Fig. 4 illustrates two techniques for extending coverage. The figure shows three parallel entries, with a leaky-feeder cable installed in the track entry. The escapeway is an open entry free of equipment that could hinder signal propagation. This type of entry provides an

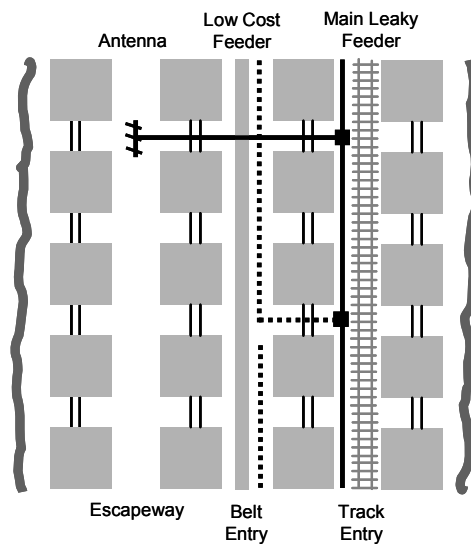

Fig. 4. Extended communications coverage.

opportunity for applying directional antennas. Special low-loss splitters are used to branch off the main leaky-feeder cable to connect antennas in the escapeway. The antennas are commonly spaced at 1000-ft intervals. Unfortunately, the belt-conveyor structure in the belt entry provides enough obstruction to render antennas ineffective. As shown in Fig. 4, stringing low-cost, leaky-feeder cable in the belt entry provides an effective alternative.

D. Survivability

The most important function of a mine communications system is to provide post-accident communications between mine workers and surface personnel. Therefore, a system's survivability after a catastrophic event, such as an explosion, fire, major roof fall, and even water inundation, is critical. Any of these events can severely damage communications infrastructure; therefore, system redundancy and component hardening are necessary for attaining survivability.

The size and layout of an underground mine can vary considerably. A significant percentage of workers are clustered in the working sections where coal is extracted, while others are scattered throughout the mine, performing safety examinations, construction, maintenance, and supply transportation. Thus, each mine must perform its own risk assessment to establish a design and layout to maximize coverage and survivability of its communications system if a catastrophic event occurs.

Component hardening can certainly improve the chances of a communications system surviving a major event. Nevertheless, it may not be practical to design components to withstand the destructive forces associated with a catastrophic event for all cases and locations in a mine.

Redundant communication paths allow for a backup path to operate in the event the primary path fails. The key is to physically isolate the redundant path so that a catastrophic event will not damage or destroy both paths.

NIOSH funded the installation of a full-scale, leaky-feeder system that extends over eight miles at a coal mine in West Virginia. For a major portion of the system, redundancy is established by providing an alternate communications path through an overland, fiber-optic link between an air shaft and the primary base station at the elevator shaft. Using an overland surface link provides the ultimate redundant path in terms of physical isolation. If the underground feeder between the two shafts is damaged or destroyed, communications are resumed through the surface link. As an example, the primary communications path in Fig. 5 is along the leaky feeder in the mine, which is connected to the primary base station, via the elevator shaft. If the feeder cable between Miners 1 and 2 is destroyed, the transmitted signal from Miner 1 is rerouted back to the air shaft and up to the secondary base station. The secondary base station then relays the signal to the primary base station over the fiber-optic link. However, this rerouting process is not seamless because of the directional issues associated with the presently-used amplifiers described earlier. Manual switching of *transmit* and *receive* frequencies is necessary. This issue should be resolved when an MSHA-approved, auto-reversing amplifier becomes available.

There are always portions of a mine where surface access cannot be utilized. In these situations, an independent, redundant path, although not as effective, can be established in a parallel entry.

E. Tracking System

The MINER Act also requires that each mine's emergency response plan includes a system that allows *above-ground personnel to determine the current or immediately pre-accident location of all underground personnel*. The enhanced leaky-feeder system is incapable of providing this function. Instead, a separate tracking system must be installed. Radio Frequency Identification (RFID) is a common tracking technique that can be employed for this application [6].

An RFID tracking system utilizes electronic *readers* and *tags*. Readers are typically installed at stationary locations throughout the mine, and each reader is encoded with a specific location identifier. A tag is usually a small transmitter, or transceiver, attached to a miner's hardhat. Each tag transmits a unique code that identifies the miner wearing the tag. With some systems, a reader transmits an interrogation signal to request a response from any tag within its range. If a tag receives an interrogation signal, it transmits its identification code to the reader. With other systems, a tag intermittently transmits its information on a continual basis. In either case, the reader then transmits its location, along with the miner's identification, to the surface

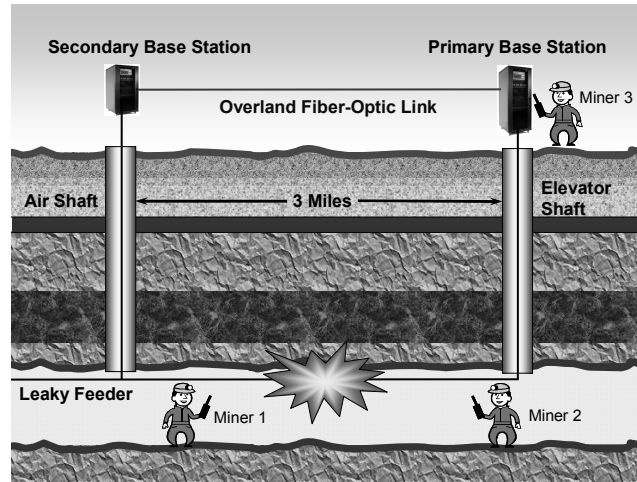

Fig. 5. Redundant path established by a surface, overland link.

control center via leaky-feeder, twisted pair, fiber-optic cable, or wireless relaying. A video monitor within the control center can then display the location of the miner on a mine map. This type of tracking is referred to as *zone-based RFID* because the miner's recorded location is within a zone defined by the reader's range and spacing. Thus, the *resolution* of the system depends on the number of readers for a given area. Some systems utilize a technique, *Received Signal Strength Indicator* (RSSI), to further improve resolution. If a miner is within range of two adjacent tags, the reader compares the signal strength from each tag and estimates the miner's location between the two points. By utilizing the changing signal strengths of the two tags, the system can also determine the miner's direction of travel. However, the accuracy of such systems can be affected by various factors, such as coal-seam undulations and equipment obstructions.

A relatively new approach, *Reverse RFID*, is being developed as an alternative. With this technique, the locations of the readers and tags are reversed, as implied by its name. Tags are installed at stationary locations throughout the mine, while each miner wears a reader on his/her belt. The tags are designed to periodically transmit their location codes. When a reader receives this information, it retransmits the tag location and the miner's identification to the leaky-feeder, which in turn transmits the information to the surface control center for processing.

A battery-powered tag, with an estimated ten-year life, is less expensive than a reader. Therefore, system resolution can be increased in a more cost-effective manner. Moreover, the system uses RSSI, to further improve resolution.

F. Advantages/Disadvantages

A major advantage of the leaky-feeder system lies in its history of successful operation in numerous mines. Thus some mine operators are familiar with the equipment and its operation. It is a demonstrated technology, and the enhanced

NIOSH-developed system provides post-accident reliability by means of redundant circuits. Expanded coverage into adjacent entries can be achieved by antennas or low-cost, leaky-feeder cable. All components of the enhanced system have received MSHA approval, and NIOSH has successfully demonstrated a full-scale system in a large operating coal mine. Power supplies and battery backups only occur in a few locations for the entire system. This is a significant advantage from a maintenance standpoint and allows the locations to receive additional roof support and protection. Furthermore, in the event of an emergency, mine rescue teams would only have to account for a few potential ignition sources, rather than accounting for batteries scattered throughout the mine. In addition, the system does not rely on proprietary protocols or software. Although the present system uses analog voice communications, the system possesses adequate bandwidth to handle digital communications, as well as other digital data.

A disadvantage of the enhanced leaker-feeder system is that feeder cable must be strung continuously throughout the mine to provide coverage wherever communications are needed. Also, the rigid construction of the cable makes it difficult to recover during retreat mining operations. The existing analog format for voice communications does not provide the versatility of a digital format. (Digital radios are available but are not yet MSHA-approved.) Another disadvantage results from the system's inability to function as a tracking system; therefore, separate tracking equipment must be purchased and installed.

III. WIRELESS-MESH SYSTEM

Wireless-mesh systems utilize discrete nodes to form a network for relaying communications signals, in a node-to-node fashion, throughout the mine or to the surface. Several types of node-based systems exist, including LAN and Wi-Fi. The type of system developed by NIOSH is referred to as an *ad hoc, partial-mesh* system.

The terms *partial-mesh* define a system in which any node can communicate with any other node *within its range*, as compared with a *full-mesh* system where all nodes are able to communicate with each other. Since a *full-mesh* system is impractical in mining applications, the term *partial* is usually dropped, and the system is simply referred to as a wireless-mesh system. Unlike the leaky-feeder system, a digital format is used, and signals are not routed through a central base station. Furthermore, the system allows direct person-to-person communications. A simplified mesh arrangement is shown in Fig. 6, with the nodes depicted as gray dots. Each node basically consists of a router, transceiver, antenna, and battery backup (Fig. 7).

A. Basic Operation

The wireless-mesh system operates within the UHF band at 900 MHz. Research shows 900 MHz to be an optimum

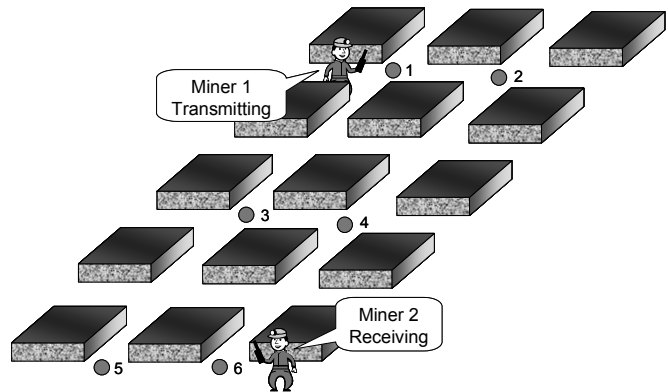

Fig. 6. Wireless-mesh system.



Fig. 7. Node components for a wireless-mesh system.

frequency for signal propagation in coal mines [5], particularly around pillars. Straight-line communication distances can extend to 2500 ft through air, but a node spacing of 1000 ft may be more realistic to provide coverage overlap. The system detects when a radio handset is within range of a node and automatically connects the radio to the network. Thus, the handsets of Miners 1 and 2 are connected to the network in Fig. 6 by *access nodes* 1 and 6, respectively. Fig. 6 shows that multiple paths are available for transmitting the signal between the sender and receiver, such as 1-2-4-6 and 1-3-5-6, with each path requiring four *hops* (number of intermediate devices between the sender and receiver). Prior to establishing communications, micro-processors within the nodes work in concert to determine the optimum path, via the *backhaul nodes*, between the sender and receiver. A handset can also function as a node for extending coverage temporarily. It should be noted that each *hop* introduces a small time delay along the communications path; however, even with extremely large mines, this should not be an issue.

The wireless-mesh system uses a modified Zigbee protocol to allow compressed voice communications, which are not supported by a true Zigbee protocol. The advantages of this approach include the following: (1) Ad hoc mesh capabilities maximize flexibility for extending and/or repairing networks, (2) Low bit-rate voice communications

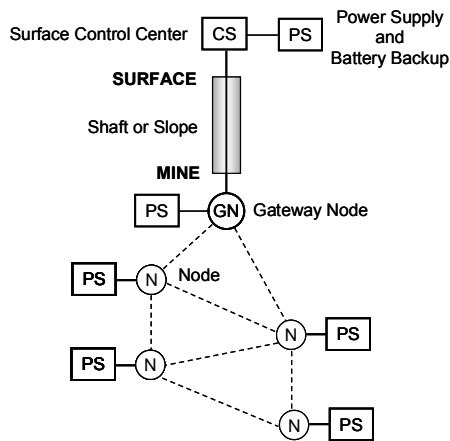

Fig. 8. Arrangement for a wireless-mesh system.

can extend the range between nodes and support future interoperability with low bit-rate systems, such as through-the-earth and medium-frequency, and (3) An operating frequency of 900 MHz has excellent in-mine propagation characteristics.

B. System Arrangement

Fig. 8 depicts a simplified arrangement for a wireless-mesh system. The solid lines indicate hard-wired connections, while the dashed lines show possible wireless connections. All communications to the surface control center must flow through a gateway node, which provides the transition between the wireless underground network and the hard-wired network at the surface control center. Fig. 8 shows the gateway node located in the mine, but it may also be located at the surface.

To avoid excessive cable runs, each node requires a battery backup, with an associated 120-Vac charging circuit. The number and arrangement of the nodes depends on the physical characteristics of the mine and the coverage, range, and overlap desired.

C. Extended Coverage

Communications coverage can be extended simply by adding nodes within the range of existing nodes, keeping in mind that each node must have access to a 120-Vac power supply. Equipment and concrete-block stoppings cause some signal attenuation, but it can be accommodated by node spacing. For extending coverage temporarily, a radio handset can act as a node as illustrated in Fig. 9.

D. Survivability

Fig. 6 shows a variety of communications paths between Miner 1 and Miner 2. If a given node fails along an established communications route, the system reconfigures its path to circumvent the failed node and maintain uninterrupted communications. With sufficient coverage overlap between nodes, the mesh arrangement exhibits an

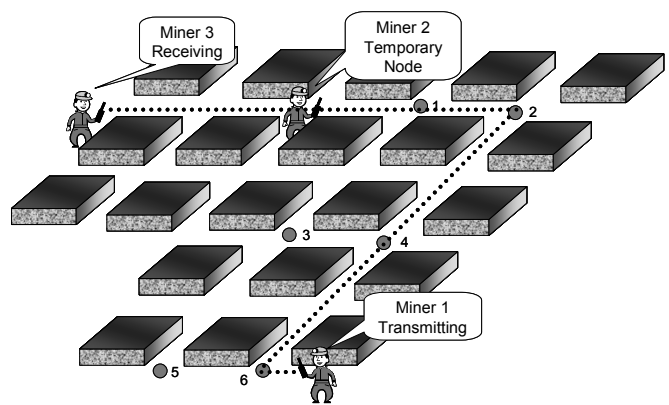

Fig. 9. Handset of Miner 2 being used as a node.

inherent redundancy, which enhances reliability by helping to ensure that the system will operate when one or more of its components fail.

A full-scale, wireless-mesh communications system was installed and successfully demonstrated at an underground coal mine in West Virginia. This installation provides wireless communications in haulage and belt entries, spanning 12,000 feet from a mining section to the surface. The in-mine installation includes 26 mesh nodes and 4 leaky-feeder bridge nodes, with 2 gateway nodes located at the shaft and slope portal entrances. A unique feature of the wireless-mesh system is its ability to connect with a leaky-feeder system, thus permitting the formulation of a hybrid communications system.

E. Tracking System

A significant advantage of the wireless-mesh system is its capability of functioning as a tracking system. This tracking capability is integrated into the communication system such that the nodes act as readers and the radio handsets act as tags. The system functions as the previously described RFID system. Similar to an RFID tag, each radio is assigned a unique identification code that is intermittently transmitted without the user's need to key the handset. The system also uses RSSI to help improve tracking accuracy. A situational-awareness video display accompanies the network servers in the mine's operations center and displays each miner's location on the mine map, as illustrated in Fig. 10.

F. Advantages/Disadvantages

Unlike the leaky-feeder system, the wireless-mesh system uses a digital format and allows direct person-to-person communications without the need for signals to be routed through a central base station. The system relays signals via nodes, eliminating the need for a feeder cable. Another advantage of the wireless-mesh system is its inherent redundancy, which significantly enhances its survivability. The system is self-healing, in that it is capable of reconfiguring its communications path to circumvent failed

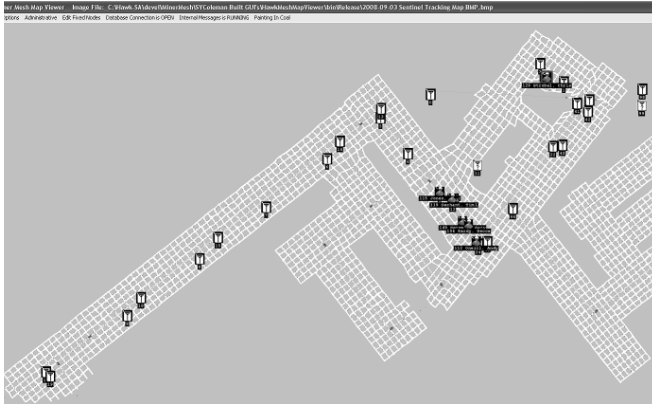

Fig. 10. Video display for wireless-mesh tracking system.

nodes. Overland communications links can also be utilized to further enhance survivability. A huge advantage of the system is its ability to function as a tracking system, as well as a communications system, thus eliminating additional equipment and its associated installation costs.

On the down side, the wireless-mesh system consists of sophisticated technology, which is new to the mining industry. As a result, it lacks a history of reliable operation in a mining environment or any application with a coverage area comparable to a mine. Furthermore, the system utilizes a proprietary protocol, which tends to eliminate the use of other manufacturers' equipment. Unlike the leaky-feeder system, battery backups are not clustered in a few locations. Instead, each node has its own battery, resulting in stored-energy sources distributed throughout the mine that may be a concern during post-accident rescue operations.

IV. MEDIUM-FREQUENCY SYSTEM

The medium-frequency (MF) system operates at 470 kHz, which is in the medium-frequency range of 300 kHz to 3000 kHz. Unlike the leaky-feeder and wireless-mesh systems, the medium-frequency system is not intended for routine mine-communications. Its primary role, instead, is to provide an alternative, communications backup in the event of an emergency. Because of its low operating frequency and power limits, this system is capable of only localized propagation through air; however, more importantly, its signal couples to any nearby metallic structures and cables [6]. This *parasitic coupling* can result in communication distances in excess of two miles.

A. Basic Operation

The medium-frequency system consists of a hand-held microphone attached to a single-channel transceiver that is connected to a ferrite loop antenna. The transceiver modulates voice communications onto a 470 kHz carrier signal. Because of the significant magnetic component at this frequency, the radiated signal couples to all conductive materials in the vicinity of its antenna, such as pre-existing



(a) Portable MF radio



(b) UHF/MF transceiver

Fig. 11. Medium-frequency devices.

phone lines, metallic lifelines, power cables, water pipes, and conveyor structures. Depending on the type of conductor, a signal can travel a few miles and still maintain enough strength to be picked up by another MF transceiver. The conductive medium acts as a distributed antenna along its entire length, similar to a leaky-feeder.

B. System Arrangement

The size of this type of radio and its associated antenna requires a carrying case the size of a briefcase, as shown in Fig. 11-a. Unlike a UHF device, the radio cannot be worn by a mine worker because of its size. As previously mentioned, these radios are intended for emergency communications, but they may find applications for routine communications in small mines. Radios can be stored at strategic locations throughout the mine to be used in emergency situations.

The medium-frequency system requires no infrastructure since it utilizes existing metallic conductors. Thus, its application is limited to mine entries with continuous metallic objects. However, twisted-pair wires can be strung through entries to allow transmission where continuous metal objects do not exist. Multiple insulated conductors, with a single end of one conductor tied to ground, provide the best signal propagation. Because of the inefficiency associated with its small antenna, the radio's antenna should be positioned very close to the transmission medium while transmitting. The distance is less critical for reception.

In addition to the portable radio, a *bridge node* (cross-band repeater) was developed to permit interconnection between UHF and MF devices and is shown in Fig. 11-b. The two globes on the enclosure separately house the UHF and MF antennas. The UHF antenna picks up the 450 MHz signal from a UHF radio handset, and the bridge node translates the frequency to 470 kHz to couple onto a metallic conductor. The reverse process occurs along the conductor downstream, as illustrated in Fig. 12.

C. Extended Coverage

An MF bridge node can be used to extend a leaky-feeder communications into a working section. A bridge node can be located near the end of a leaky-feeder cable and re-propagate the UHF signal onto a power, or other, conductor

as a MF signal. Another bridge node can be used to re-convert the MF signal back to UHF in the working section.

If a twisted-pair conductor is used as the transmission medium, branch conductors can be used to extend coverage into crosscuts. Experimentation with the connections may be required to maximize signal strength in these branches.

Present medium-frequency systems are analog systems that support voice communications. Thus, if nodes are used to extend coverage, noise is amplified along with the signal. Even though the lower bit rate associated with medium frequencies creates a challenge, a digital system is being developed to eliminate the cumulative effect with noise amplification.

D. Survivability

Post-accident investigations have shown that large-diameter power conductors often survive, and maintain their continuity, after a catastrophic event. Thus, medium-frequency systems could play an invaluable role in post-accident escape and rescue procedures. In addition, redundant circuits of inexpensive twisted-pair conductors could be installed in a fashion similar to leaky feeders.

E. Tracking Systems

The medium-frequency system is designed to be an emergency voice communications system, and it has no tracking capabilities. Also, since the present MF system is an analog system, it is incapable of being used for transmitting tracking data to the surface. However, as mentioned above, a digital system with this capability should be available in the near future.

F. Advantages/Disadvantages

The medium-frequency system provides a relatively inexpensive method for emergency communications. It does not require a dedicated conductor for establishing communications, and metallic conductors often survive catastrophic events. Inexpensive twisted-pair conductors can be used if a dedicated conductor is desired. The MF system's operation is simple and does not require proprietary protocols. A bridge node allows the use of standard UHF handsets and can be used for extending a leaky-feeder.

A disadvantage of the medium-frequency system is that it cannot be used for primary communications, except in very small mines. Although the device is portable, it is not wearable like a UHF radio. The MF system does not have tracking capabilities, and it is not yet MSHA-approved for post-accident applications, although it is in the approval process at the time of this writing.

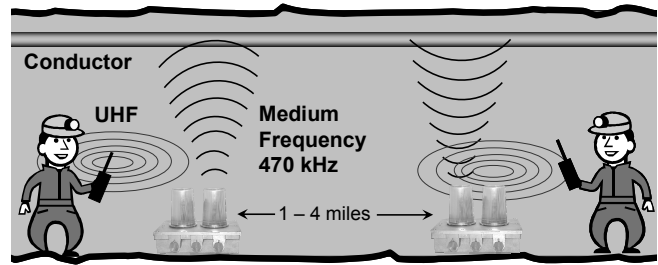

Fig. 12. Medium-frequency bridge nodes.

V. CONCLUSIONS

Wireless mine communications technologies and associated tracking systems were described in this paper. These systems represent dramatic improvements in post-accident communications, as compared with existing systems. While the operational characteristics of these systems fall short of being perfect, mineworkers will be afforded far superior post-accident functionality. Future enhancements and interoperability features will further improve post-accident system availability in those applications where two or more system types have been incorporated into the overall system design.

Some mines will be able to meet their communications needs with only one type of system, while other mines may require a combination of systems. The leaky feeder and wireless-mesh systems are designed for routine, as well as emergency, communications. As such, it is anticipated that mines will experience benefits, other than safety, from the expanded capabilities of these systems.

REFERENCES

- [1] United States Public Laws, PL 109-236, "Mine Improvement and New Emergency Response Act of 2006 (MINER Act)," Jun. 15, 2006.
- [2] Nutter, R.S., "Underground Coal Mine Communications and Tracking Status – Sago Plus One Year," *Conference Record of the IEEE Industry Applications Society*, Oct. 2007, New Orleans, pp. 2086-2089.
- [3] Code of Federal Regulations, Title 30, Part 75.506, "Electric face equipment; requirements for permissibility."
- [4] Martin, D.J.R., "Leaky-feeder radio communications: A historical review," *34th IEEE Vehicular Technology Conference*, May 1984, vol. 34, pp. 25-30.
- [5] Emslie, A.G., R.L. Lagace, and P.F. Strong, "Theory of the propagation of UHF radio waves in coal mine tunnels," *IEEE Transactions on Antennas and Propagation*, Mar. 1975, vol. AP-23, No. 2, pp. 192-205.
- [6] Anonymous, "Radio Frequency Identification RFID - A basic primer," Association for Automatic Identification and Mobility (AIM) Inc. WP-98/002R2, Version 1.3, 2007.
- [7] Sacks, H.K. and R.L. Chufo, "Medium-frequency propagation in coal mines," *Proceedings of the Fourth WVU Conference on Coal Mine Electro-Technology*, M.D. Aldridge, ed. Morgantown, WV, Aug. 1978, pp. 27-1 – 27-12.