

Monitoring and removal of CO in blasting operations

Marcia L. Harris*, Richard J. Mainiero

*National Institute for Occupational Safety and Health, Pittsburgh Research Laboratory,
626 Cochrans Mill Road, P.O. Box 18070, Pittsburgh, PA 15236, USA*

Received 20 June 2007; received in revised form 5 September 2007; accepted 4 October 2007

Abstract

Toxic fumes produced by detonating explosives in surface mining and construction operations pose potential hazards to workers and the public. Blasting operations produce both toxic and nontoxic gaseous products; the toxic products are mainly carbon monoxide (CO) and the oxides of nitrogen (NO_x). Since 1988, there have been 17 documented incidents in the United States and Canada in which carbon monoxide (CO) is suspected to have migrated through ground strata into occupied enclosed spaces as a result of proximate trench blasting or surface mine blasting. These incidents resulted in 39 suspected or medically verified carbon monoxide poisonings as well as one fatality. At worst people may be fatally poisoned and the least to be expected is increased public objections to blasting. Local and state agencies could demand a cessation of the blasting requiring more expensive mechanical means to break the rock. This paper discusses the most feasible means of preventing CO migration, mitigating CO that has migrated, and detecting CO in an underground enclosed space and may help reduce the exposure of unsuspecting area residents to carbon monoxide and help prevent the implementation of unnecessary regulations and limitations on blasting. Single-hole shots and small-scale multiple-hole blasts were performed that indicate promising means of prevention and mitigation.

Published by Elsevier Ltd.

Keywords: Explosives; Blasting; Carbon monoxide; Fumes; CO poisoning

1. Problem

A potential hazard to workers and the public exists in surface mining and construction operations when explosives blasting is conducted. Blasting operations produce both toxic and nontoxic gaseous products; the toxic products are mainly carbon monoxide (CO) and the oxides of nitrogen (NO_x). The implications and possibilities for minimization of such products have been studied for decades. Early research addressed toxicity issues associated with blasting in confined spaces such as underground coal mines. Over the past decade there has been an increased interest in the toxic gases that are released during some large surface mine blasts. At the same time, the mining and construction industries have been concerned with toxic detonation products that may travel laterally through the earth rather than vent to the atmosphere. Since 1988, there have

* Corresponding author. Tel.: +1 412 386 5780; fax: +1 412 386 6595.

E-mail addresses: mharris@cdc.gov (M.L. Harris), rmainiero@cdc.gov (R.J. Mainiero).

been 17 reported incidents where explosive-generated CO moved through the earth and accumulated in nearby underground enclosed spaces (Santis, 2001; Martel et al., 2001; Harris et al., 2004a,b). Investigators could usually identify a probable pathway from the blast to the affected structure. Likely pathways included old trenches filled with porous material intersecting the blast site, horizontal sedimentary bedding, unconsolidated material in a horizontal plane, and hill seams (a pathway caused by a movement of rock layers on a hill side) together with sumps, drains, the gaps between basement floors and walls, unlined wells, and direct openings (such as cracks) in structure walls. These reported incidents resulted in 39 suspected or medically verified CO poisonings as well as one fatality. Santis (2001) summarizes 10 of the incidents that occurred in private residences and one that occurred in a manhole. In each case, overburden heavily confined the explosive in the blasts, restricting the venting of explosive gases directly to the atmosphere. All the blasts were in or near residential areas and none of the blasts were excavated immediately. Five of the blasts were within 6.1–15.2 m of the affected homes, three were 30.5–45.7 m away, and one was 122 m away. The single fatality resulted from blasting-produced CO migrating into a manhole pit.

In open-pit blasting operations, wind rapidly dilutes the vented gases during the fragmentation process and continues to dilute the gases slowly emanating from the muck pile. Generally, trench blasting near occupied dwellings is done with heavy explosive confinement with a focus on preventing fly rock and minimizing air blast damage. Consequently, there is little to no surface heave or venting for most of the shots.

2. Background

Explosive produced CO migrating from a blast into nearby enclosed spaces appears to be a recently documented development with cases first documented in 1988. This may be due to more blasting occurring in suburban environments. Since then, similar cases have occurred and been documented (Santis, 2001). Several preventative and mitigative techniques have been recommended but there has only been one previous study examining CO migration from a blast site which concluded the methods used did not significantly limit the CO production and migration (Martel et al., 2001). Blasters need to know which techniques are most likely to be successful.

Several methods of prevention and mitigation have been applied when an instance of CO migration has been encountered. These methods include immediate excavation of the shot, installation of vent holes on the top of the shot, excavation of a trench in an attempt to intercept the migration pathways, installation of PVC-piped vent holes for negative pressure application near the affected structure, and blast plan modification. In the cases when vent holes were excavated on top of the shot and an intercepting trench were employed, the CO either continued to migrate or these tactics were ineffective in removing the existing CO from the ground (Harris et al., 2004a). Excavation and refill of the blasted material after each blast, installation of vents around a blast, blasting sequence modification, and explosive type modification did not have a significant effect on limiting the CO production and migration (Martel et al., 2001).

In 2002, a blasting-related CO migration incident occurred in Amherst, New York (Harris et al., 2004b). During the project, many techniques were employed in an attempt to prevent CO from migrating away from the blast and into nearby homes or businesses. Some of these techniques included removing the loose top material before blasting combined with using blast mats for flyrock prevention, blasting into an open pit to provide movement for release of the fumes, blasting no more than twice a day in a given area, and changing the explosives used. The technique that appeared to best prevent CO from migrating was applying negative pressure from the drill's dust collection system over a borehole near the muck pile to pull the CO out of the ground. No CO appeared in nearby underground structures while employing the negative pressure. However, in a case where conditions would not permit negative pressure application, nearby storm sewer manholes measured in excess of 1500 ppm CO after the shot. Immediate excavation was not a viable option in Amherst but at a construction site in Latrobe, Pennsylvania, excavation of a blasted material without refilling appeared to show some promise (Harris et al., 2005).

The two most successful techniques for preventing CO migration were the use of a vacuum to pull CO out of the ground and immediate excavation after the shot; both of these techniques are also recommended by the Institute of Makers of Explosives (2001). To further evaluate these techniques, research programs were carried out at the National Institute for Occupational Safety and Health (NIOSH), Pittsburgh Research Lab (PRL).

A 2004 study involving the injection of CO into 3 m deep boreholes at PRL demonstrated that CO can migrate through the surrounding ground strata and remain in the ground for several days (Harris et al., 2005). Negative pressure applied to boreholes around the injection site demonstrated that CO can be pulled out of the ground, thereby lessening the horizontal migration of CO in the ground. The tests showed a dramatic difference between the natural rate of CO decrease within surrounding strata and the rapid rate of decline with the application of negative pressure. The research described in this paper examines the effects of negative pressure application and immediate excavation after single-hole and multiple-hole blasts.

3. Method

3.1. Single-hole detonations

Field studies were conducted at the NIOSH PRL site. The study began with single-borehole shots and later tested multiple-borehole shots. The initial study was conducted using nineteen, 6.35 cm diameter monitoring holes drilled approximately 3 m deep and approximately 1.5 m apart (Fig. 1). The holes were lined with 3 m long, 5 cm inside diameter (ID) PVC pipe (Fig. 2). The bottom 1.5 m of the pipe was perforated with multiple rows of 0.64 cm diameter holes spaced 8 cm apart vertically every 90° around the pipe circumference to allow for infiltration of gases from the ground. Each monitoring hole was equipped with a PVC cap that included a port for installing two 0.64 cm outside diameter (OD) sampling tubes. One line was extended approximately 2.4 m into the hole and the other extended approximately 0.3 m into the hole.

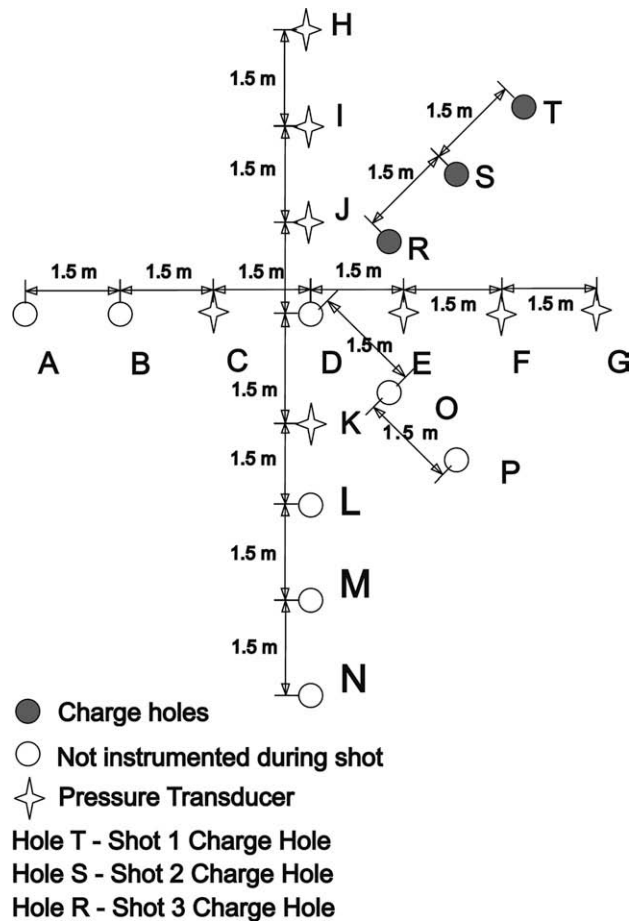

Fig. 1. Layout of single-hole shots.

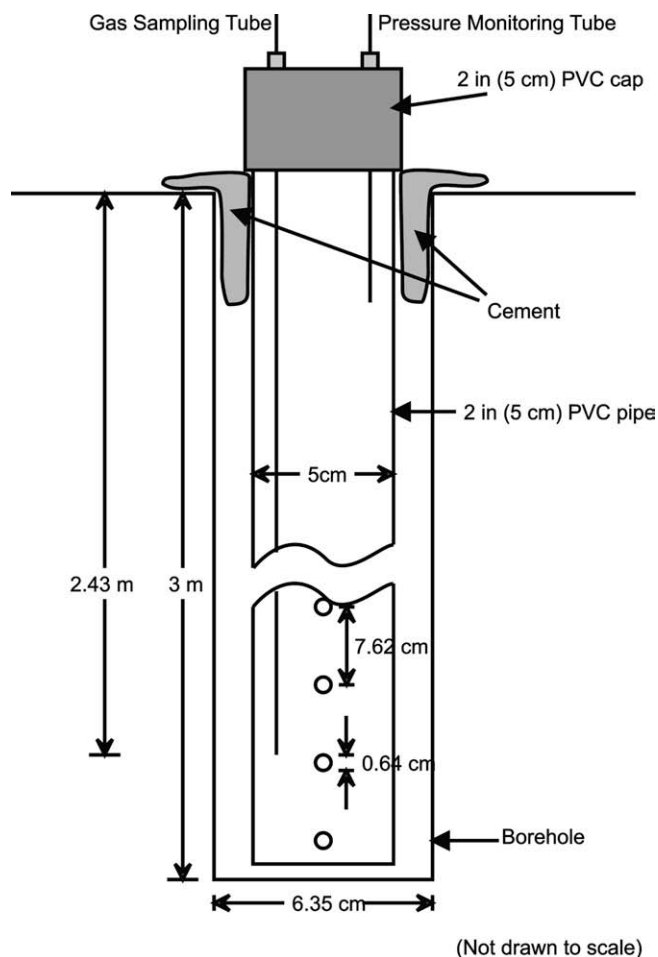

Fig. 2. Monitoring hole configuration.

Prior to each shot, instrumentation for acquiring pressure and vibration data was set up. Pressure measurements at the time of detonation were obtained from pressure transducers placed on the short (0.3 m depth) tube. A total of eight transducers were used to measure pressure histories at surrounding monitoring holes. Table 1 details the experimental setups for shots 1–3. The explosive charge was placed at the bottom of the hole and the remainder of the hole was stemmed with sand.

A cap-sensitive emulsion or dynamite was used in all of the shots. TNT has been shown to produce significant quantities of CO when detonated in the absence of oxygen (Harris et al., 2003; Urbanski, 1964). Therefore, to ensure that a large quantity of CO was produced and available for migration, every hole was loaded with a 50/50 PETN/TNT cast booster (5 cm diameter by 5 cm long) in addition to the other cap-sensitive emulsion explosive.

After the detonation, the pressure transducers were removed from the various holes and on-line gas analyzers were installed. Two Testo 350¹ electrochemical cell-based gas analyzers were used to determine periodically the concentration of CO, NO, NO₂, and O₂ in the holes surrounding the shot hole. To avoid sample dilution in the monitoring hole, the analyzer pump drew the sample from the tube placed near the bottom of the hole while the exhaust from the analyzer was returned to the top tube, thus maintaining a closed system. The instruments were allowed to sample for more than 2 min at a rate of 1.2 L/min before stabilized

¹ Reference to specific products does not imply endorsement by NIOSH.

Table 1
Instrumentation of single-hole shots

Shot designation	Charge holes	Total charge weight (kg)	Pressure transducer placement	Mini-seismograph placement	Gas analyzer placement
1	T	1.766	C E F G H I J K	E G H J	F R
2	S	1.660	C E F G H I J K	E G H J	E I
3	R	1.653	C E F G H I J K	C G H K	I K

measurements were recorded. Barometric pressure data were obtained from the Allegheny County Regional Airport located 7 km from PRL.

Negative pressure application during the single-hole shots was applied by connecting the hose of an ordinary shop vacuum to a monitoring hole liner. Fig. 3 illustrates this application.



Fig. 3. Negative pressure application using a Shop-Vac.

3.2. Multiple-hole detonations

For the multiple-hole shots, the same sampling method was employed. The liners were the same although the shots and monitoring holes were located in a different location at PRL. Fig. 4 illustrates the layout for the shots. Table 2 lists the charge weights used in shots 4–6, as well as the placement of mini-seismographs and pressure transducers. In Table 2, R refers to row, H refers to hole, and M refers to monitoring hole.

Each of the multiple-hole shots was intended to consist of 6 holes. Shots 5 and 6, however, ultimately were comprised of 5 holes. During the loading of shot 5, one of the charges would not safely load into Hole R4H3. Some holes were already loaded and stemmed. Therefore, the decision was made to load the remainder of the holes and proceed with the shot. Only 5 holes were loaded for shot 6 because the R5H2 PVC pipe liner was damaged during the application of negative pressure after shot 5. The liner could not be removed or safely loaded with a charge.

The drill rig’s dust collection system was used as the source of negative pressure for the multiple hole shots. In Fig. 5, the end of the drill boom was set on top of a lined drill hole. The dust collector was started and ran for more than 2 h.

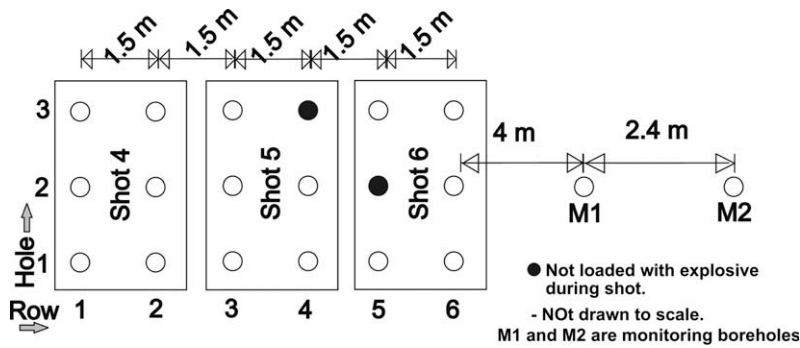

Fig. 4. Layout of multiple-hole shots.

Table 2
Instrumentation of multiple-hole shots

Shot designation	Charge holes (delays (ms))	Total charge weight (kg)	Pressure transducer placement	Mini-seismograph placement
4	R1H1 (0)	1.475	R6H1	R6H1
	R1H2 (25)	1.470	M1	M1
	R1H3 (100)	1.448	M2	M2
	R2H1 (175)	1.463		
	R2H2 (250)	1.442		
	R2H3 (300)	1.455		
5	R3H1 (0)	1.484	M1	M1
	R3H2 (25)	1.489	M2	M2
	R3H3 (100)	1.486		
	R4H1 (175)	1.487		
	R4H2 (250)	1.692		
6	R5H1 (0)	1.914	M1	M1
	R5H3 (25)	1.880	M2	M2
	R6H1 (100)	1.889		
	R6H2 (175)	1.910		
	R6H3 (250)	1.926		



Fig. 5. Negative pressure application using the drill rig dust collection system.

4. Results

A single-hole shot was conducted in Hole R (Fig. 1) and no attempt was made to prevent migration or to remove CO from the ground. Fig. 6 displays the continuous sampling of Holes K and I over a 17-h time period starting about 5 h after the shot. During the first 8 h of sampling on Hole K (2.9 m from the shot), the CO increased to a measurement of 7200 ppm before starting a decline almost 14 h after the shot. Likewise, the CO measurements from Hole I (2.3 m from the shot) increased to a maximum value of 3500 ppm, 10 h after the detonation before starting to decrease. The barometric pressure history is also displayed in Fig. 6. During this time frame, it does not appear that barometric pressure had an effect on the CO measured in the holes and without mitigation, it required an extended period of time for the detonation fumes to disperse.

A negative pressure was applied to Hole S after a charge was detonated in Hole T. Fig. 7 shows the negative pressure applied 2 h after the detonation of the main explosive charge. The continuous sampling for one half-hour

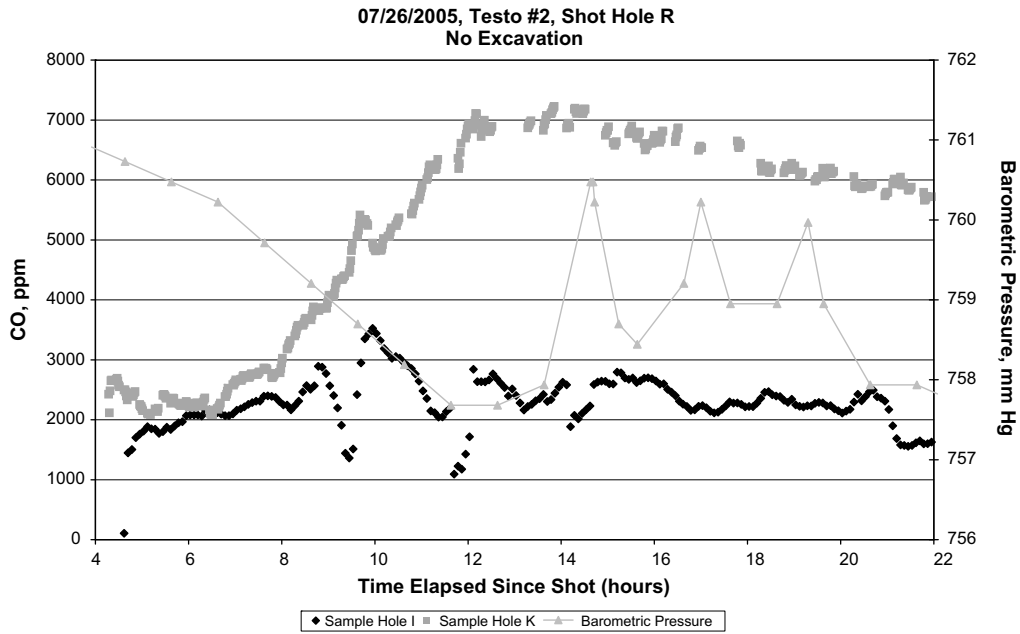

Fig. 6. CO measurements over time without mitigation.

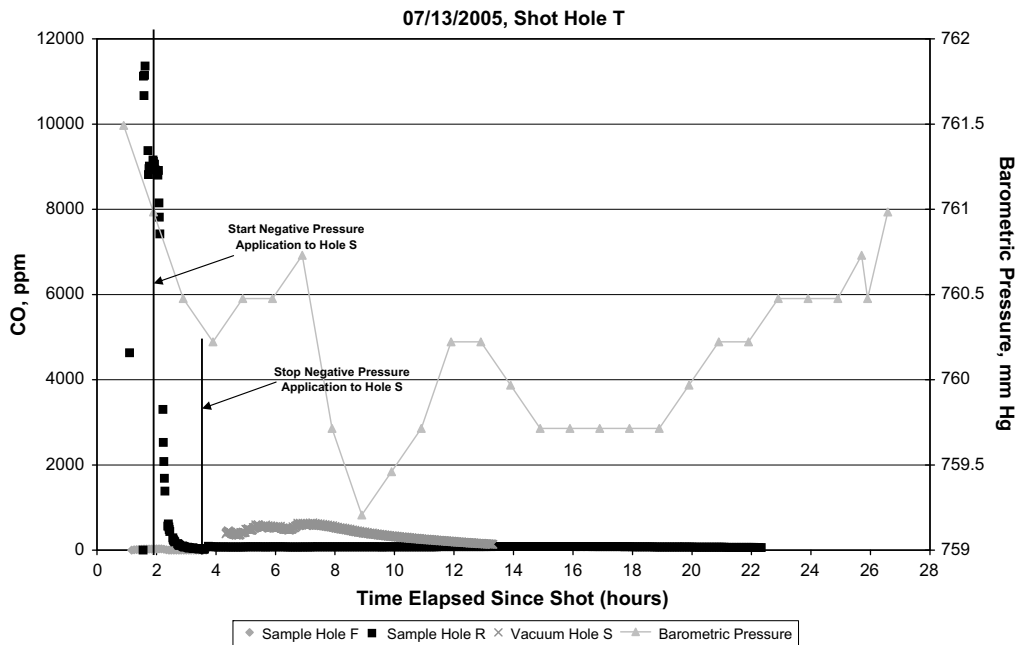

Fig. 7. CO measurements over time with vacuum application.

before negative pressure application measured CO greater than 7000 ppm, sometimes greater than 11,000 ppm. When the negative pressure was applied to Hole S, CO levels were halved within 2 min. One half-hour later, the CO measurements within Hole R dropped from 7000 to 200 ppm. Hole F did not accumulate as much CO as Hole R. The highest measurement of CO in Hole F was 30 ppm, 2 h after the detonation. When the vacuum was applied 2 h after the detonation, the measurements of CO immediately decreased

to and remained at zero within a couple minutes. By applying a negative pressure near the shot or source of fumes, the gases were removed before they could migrate.

After a charge was detonated in Hole S, the charge hole was excavated. Excavation started approximately one half-hour after the detonation. Fig. 8 shows that Hole E had CO measurements as high as 12,000 ppm about 1 h and 45 min after the shot. The CO decreased over the next 3 h until it was less than 500 ppm. Overnight, the CO measurements in Hole E eventually declined to 100 ppm. Within 5 h after the charge detonation, Hole I measured 700 ppm CO. After 5 h, the CO measurements started to decrease until they were 20 ppm or less 22 h after the shot. Immediate excavation of the shot was another way to remove the fumes along with the shot material from the ground before the gases could migrate.

In an attempt to account for the distance of the monitoring hole from the shot and the weight of explosives used in the blast, the scaled distance for each monitoring hole was calculated. The scaled distance is commonly used in predicting the peak particle velocity of seismic waves. The scaled distance, SD, is calculated as

$$SD = d/(W)^{1/3} \tag{1}$$

where d is the distance from the shot in meters and W is the total weight of explosive charges in kg (Hopler, 1998). The scaled distance for each monitoring hole was calculated for holes approximately 1.5 and 3 m from the shots in which CO was measured. Fig. 9 displays the measured CO/SD vs. the time elapsed since blast detonation for shots 1, 2, and 3.

When immediate excavation occurred, after an initial high CO/SD over 17,000 at 1.5 m from the shot, the CO/SD dramatically decreased to less than 200 approximately 28 h after detonation. At a hole 3 m from the shot, the CO/SD peak was nearly 800 which then also decreased to 4 within 28 h. Similar results were seen immediately upon vacuum application. When vacuum was applied, the CO/SD was 3800 at 3 m from the shot but reduced to less than 9 about 3.5 h after detonation. At a location 1.5 m from the shot, the CO/SD was 1200 and reduced to 220 within 3.5 h. The reductions of CO/SD occur, in both cases, within 28 h or just a little over 1 day. However, when nothing is done to abate the CO within the ground, the time frame becomes much longer. The CO/SD is 10,500 within the first hour and slowly declines over the next 72 h to 630 at a point 1.5 m from the shot. The CO/SD values at a location 3 m from the shot reach 155 which is not as high but they

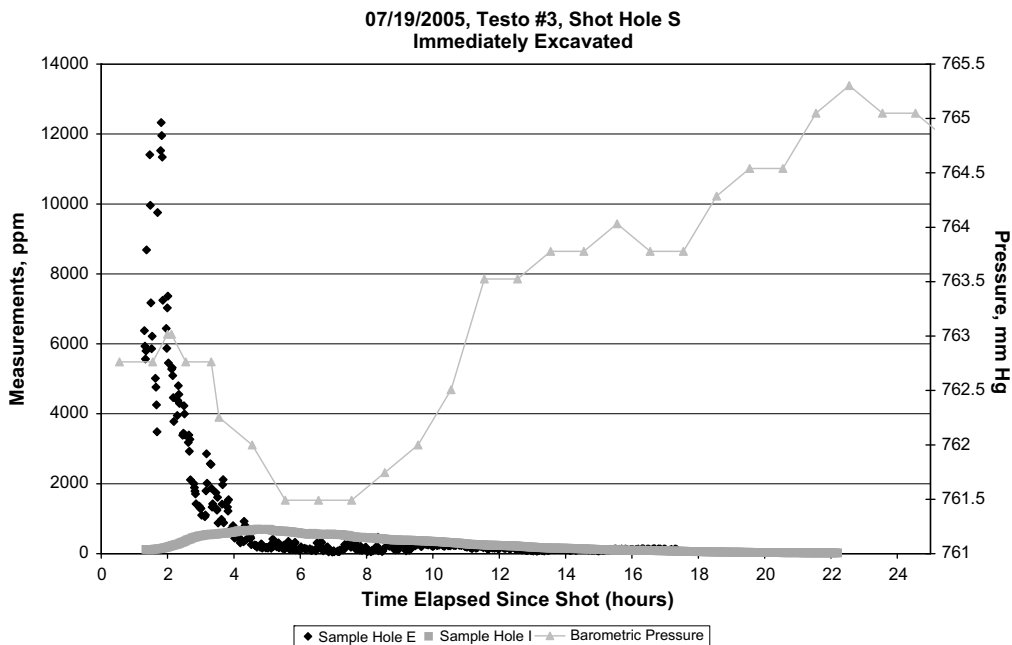

Fig. 8. CO measurements over time with immediate excavation.

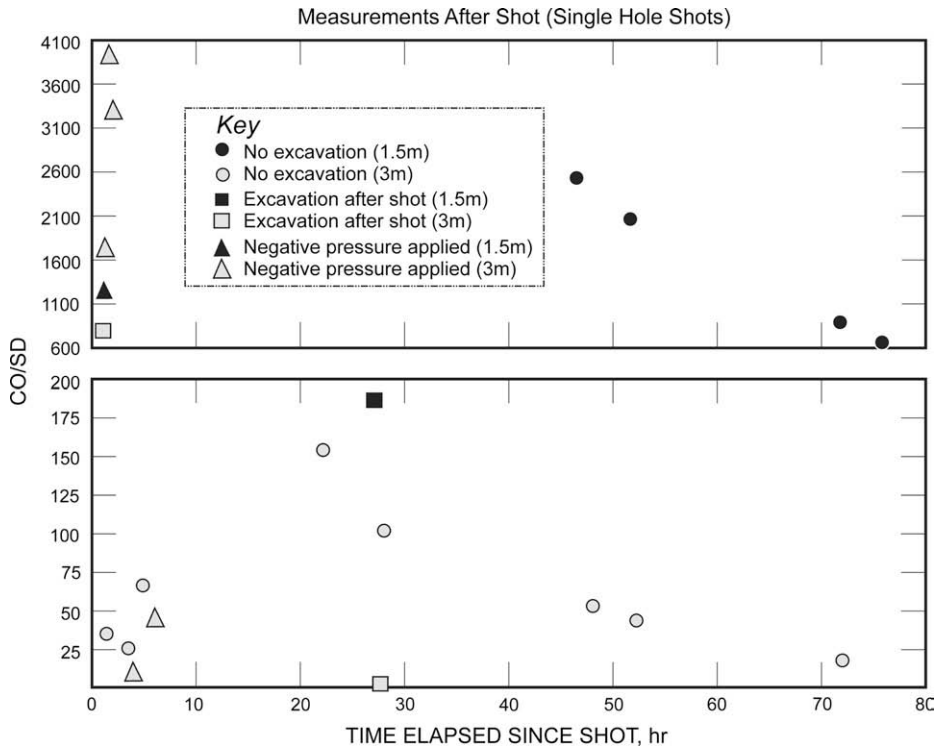

Fig. 9. CO measurements over time comparing no action, immediate excavation, and negative pressure application after single-hole shots. do take as long to lessen to 17. The advantages of using negative pressure extraction such as quick, timely, and localized fumes extraction are displayed.

Some multiple-hole shots were performed in an attempt to repeat the results of the single-hole shots but on a larger scale. In Fig. 10, measurements taken in a hole 1.5 m from the edge of Shot 4 are shown. The CO

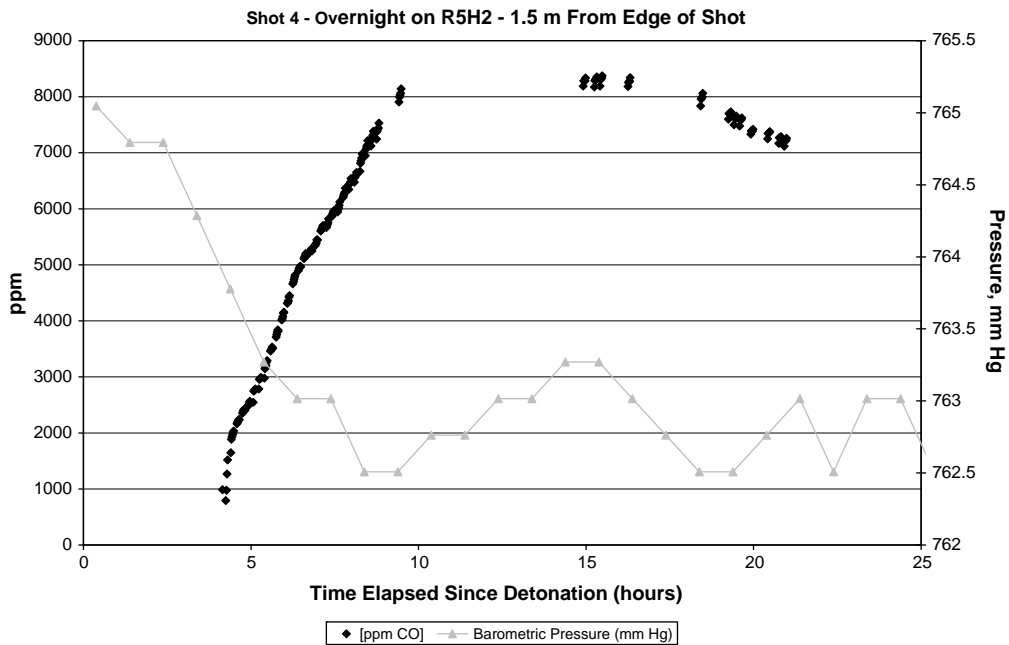

Fig. 10. CO measurements over time after a multiple-hole shot without mitigation.

measured within the hole exceeded 8000 ppm about 9.5 h after the shot detonated. Twenty hours after the shot detonation, it appears the CO was starting to decline at a relatively slow rate. A gap appears in the continuous monitoring data due to an automatic rinsing of the CO detector cell with fresh air when the CO measurements are too high; this prevents failure of the electrochemical cell. The barometric pressure is also plotted. The barometric pressure appears not to affect the rate of increase or decrease within the first 24 h after detonation. Again, without mitigation, it takes an extended period of time for the detonation fumes to disperse.

Fig. 11 displays a comparison of CO measurements after multiple-hole shots with and without excavation and with negative pressure application. Without excavation, the highest CO/SD for Hole R5H1, 2.7 m from the shot edge, was 4066 (off scale). The CO/SD decreased over a period of several days until they measured less than 122. When shot excavation was performed immediately after detonation, the maximum CO/SD from the shot edge was only 100. Fig. 11 shows the duration of CO presence after immediate excavation to be significantly shorter than when nothing was done. When a negative pressure was applied, the CO/SD 5.8 m from the shot edge never rose higher than 15. With the 2 forms of intervention, the CO/SD was comparatively much lower and of shorter duration.

Fig. 12 displays the CO/SD during the first 50 h after the multiple-hole shot detonations. The time durations of the negative pressure application and shot excavation are shown. Both commenced approximately 45 min after shot detonation. The excavated shot was open for approximately 22 h, while vacuum was applied for 2 h. Again with no intervention, peak CO levels are higher and last longer than when preventive or remedial actions are taken.

5. Discussion

There are several factors that cannot be controlled or predicted with the tests performed or other tests like these. The naturally occurring fracture system may be predicted somewhat if there is an outcrop or geologic data which indicate the general fracture orientation. However, geological anomalies and fractures may not be readily apparent. With each successive blast, new fracture patterns are created that may serve as potential pathways for CO migration. The measurements at one location after one shot may not be relevant at the same distance after another shot due to newly created pathways. Therefore, the results reported here can be evaluated qualitatively but not quantitatively.

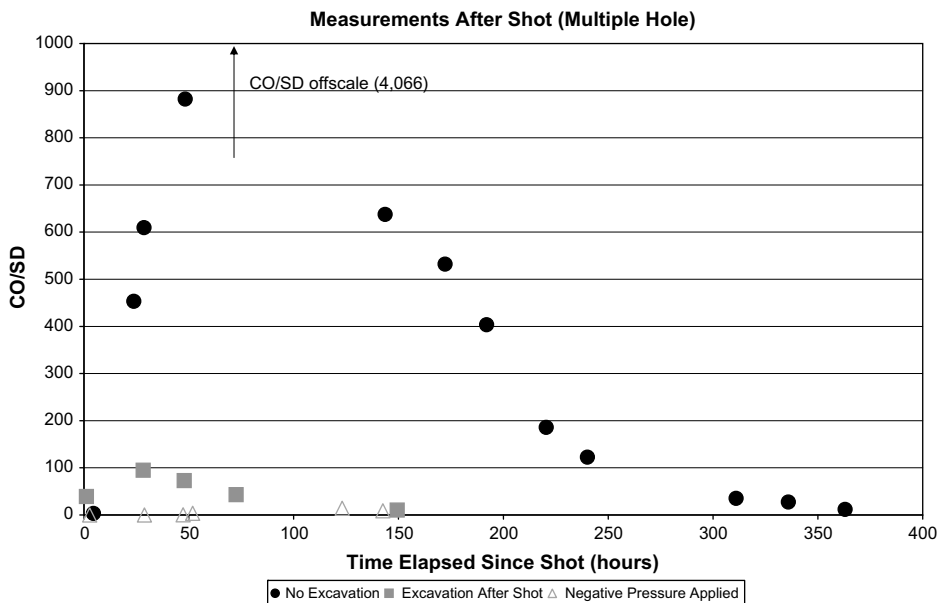

Fig. 11. CO measurements over time comparing no action, immediate excavation, and negative pressure application after multiple-hole shots.

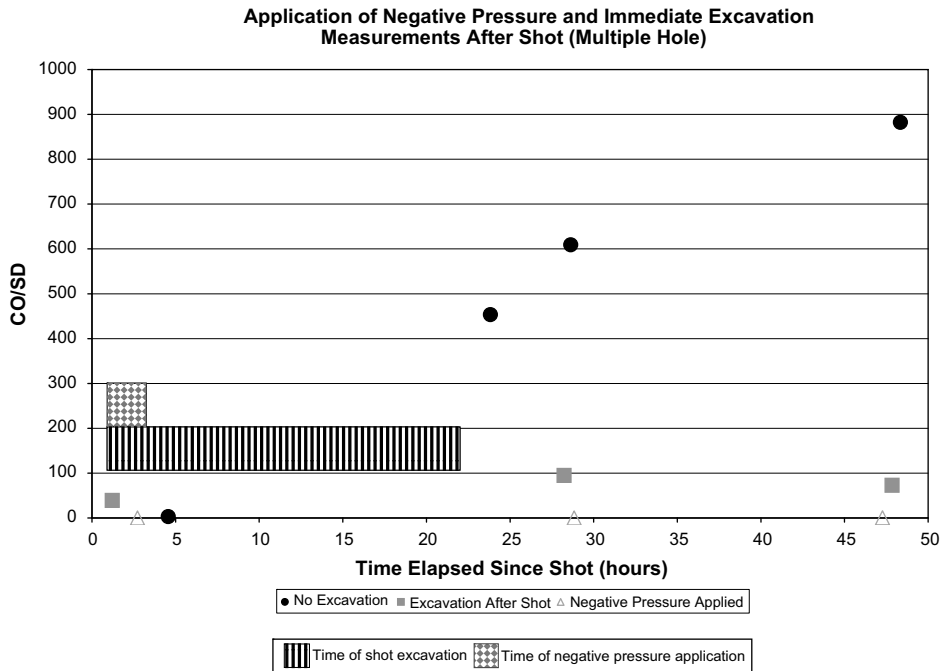

Fig. 12. Application of negative pressure and immediate excavation measurements after shot.

In both the single-hole and multiple-hole shots and without any intervention, CO remains in the ground for significantly long periods of time. The NIOSH recommended exposure limit (REL) is 200 ppm (NIOSH, 2005). In these two instances, CO measured greater than 200 ppm in some sample locations more than 3 and 9 days after the detonations (single hole shots 1.5 m from shot edge and multiple hole shots, 2.7 m from shot edge). Fig. 9 displays CO/SD values at 1.5 and 3 m from single-hole blasts. Without intervention, the values appeared to peak 3 m from the shot 22 h after the detonation. The values slowly declined over a period of 3 days. Fig. 11 also displays measurable CO levels more than 2 weeks after the multiple-hole detonations.

When excavation was performed after shot detonation, most of the CO appears to be removed along with the muck pile. When comparing Figs. 6 and 8, the effects of excavation are clearly shown. Although the maximum CO value was higher in Fig. 8 (>12,000 ppm at Hole E) the values quickly dropped within 5 h and remained lower than 700 ppm when excavation was performed. Over a period of hours, the levels of CO increased to greater than 7000 ppm (Hole K) as shown in Fig. 6. Only after nearly 14 h without any intervention do the CO rates start to decline, but the rate of decline is much slower than with excavation (Fig. 8). Similar results can also be seen in Fig. 9. Fig. 11 displays results after multiple-hole shots. Without excavation much higher CO/SD values are depicted and remain for a longer duration than when excavation is performed.

The effects of negative pressure application are shown in Fig. 7 after a single-hole detonation. Fig. 12 also shows that by applying a negative pressure, CO did not accumulate within the sampling holes. Negative pressure has been applied in past CO migration incidents. As in Amherst, New York, the negative pressure was applied close to the blast site with no resulting migration (Harris et al., 2004b). It would be best to apply the negative pressure as close to the blast site as possible when trying to mitigate the impacts of CO migration. If the negative pressure is applied closer to an occupied underground space than to the blast, there is potential that the CO would be drawn to the occupied area and create more of a hazard. Also, the location of the dust collection system exhaust should be known and avoided to prevent CO poisoning by the drill operator. The driller should also take the precaution of wearing a personal CO monitor to ensure no possible overexposure to CO while applying negative pressure with the drill rig.

The effects of weather were not investigated in this study but may have an effect. However, barometric pressure changes did not appear to affect the CO transport. No apparent correlations between the rate of CO increase/decrease and barometric pressure were seen in Figs. 6–8, or 10.

6. Summary

After a blast, CO can migrate through the ground and into underground enclosed spaces. CO may not appear for several hours, but once it does appear, it can linger for several days. Barometric pressure changes do not appear to affect the increase or decrease of CO migration. The results reported here suggest that application of negative pressure to a borehole is the most effective way to remove CO from the ground. Negative pressure applied away from occupied buildings can minimize CO migration. An available source of negative pressure is the dust collector on the drill rig. By placing the drill boom over an existing open hole near the blast, the dust collector would be large enough to create a negative pressure at a high flow rate. Immediate excavation also removes the CO before it has time to migrate, but this is not as effective as application of negative pressure. The most promising, cost-effective, and feasible methods appear to be application of negative pressure near the blast site to mitigate CO and immediate excavation to prevent CO accumulation and migration.

The findings and conclusions in this report are those of the author(s) and do not necessarily represent the views of the National Institute for Occupational Safety and Health.

References

- Harris, M.L., Rowland, J.H., Mainiero, R.J., 2003. In: Toxic fume comparison of a few explosives used in trench blasting, vol. 2. International Society of Explosives Engineers, pp. 319–336.
- Harris, M.L., Rowland, J.H., Mainiero, R.J., 2004a. In: Blasting related carbon monoxide incident in Bristow, Virginia, vol. 2. International Society of Explosives Engineers, pp. 319–327.
- Harris, M.L., Rowland, J.H., Mainiero, R.J., 2004b. In: CO migration from trench blasting in Amherst, New York, vol. 2. International Society of Explosives Engineers, pp. 25–39.
- Harris, M.L., Sapko, M.J., Mainiero, R.J., 2005. In: Field studies of CO migration from blasting, vol. 2. International Society of Explosives Engineers, pp. 49–69.
- Hopler, R.B. (Ed.), 1998. *Blasters' Handbook*, 17th ed. International Society of Explosives Engineers (ISEE).
- Institute of Makers of Explosives, 2001. Fumes from Blasting Operations. <http://www.ime.org/dynamic.php?page_id=48>] (accessed 24.08.2007).
- Martel, R., Trepanier, L., Boutin, L., Lavigne, M., Lévesque, B., Sanfaçon, V., Auger, P., Galarneau, L., Brousseau, P., 2001. Carbon monoxide poisoning from blasting operation in construction works. *An Earth Odyssey*, 1456–1464.
- NIOSH, 2005. NIOSH Pocket Guide to Chemical Hazards. DHHS (NIOSH) Publication No. 2005-151.
- Santis, L.D., 2001. A summary of subsurface carbon monoxide migration incidents. In: *Proceedings of the Twenty-Seventh Annual Conference on Explosives and Blasting Technique*. International Society of Explosives Engineers 2-AS, pp. 143–154.
- Urbanski, T., 1964. *Chemistry and Technology of Explosives*, MacMillan, New York, Vol. 1, pp. 318–319.