

EVALUATION OF MINE ILLUMINATION SYSTEMS  
USING NUMERICAL MODELING

Thomas Novak  
Pittsburgh Mining and Safety Research Center  
Bureau of Mines  
U.S. Department of the Interior  
Pittsburgh, PA

Robert Goldstein  
Mathematical Applications Group, Inc.  
Elmsford, NY

ABSTRACT

The analysis of a machine-luminaire configuration is a time-consuming process requiring the construction of a machine mockup, installation of a designated lighting arrangement, and an extensive set of illumination measurements. This entire process, however, is well suited to computer analysis. By simulating the machine geometry and the characteristics of the desired luminaires, the incident light levels can be calculated at the required set of points. This Bureau of Mines paper presents a general description of the techniques involved in performing this simulation.

INTRODUCTION

The Mine Safety and Health Administration (MSHA), U.S. Department of Labor, provides a method of evaluating an illumination system prior to its installation in an underground coal mine. This method requires the construction of a machine mockup that conforms to the shape and dimensions of the actual mining machine on which the lighting fixtures will be mounted. The designated luminaires are mounted on the mockup at their specified locations, with their proper orientations. The mockup, with its associated illumination system, is then centered in a simulated mine entry, which is a black room that excludes all exterior light. This room has movable roof and walls which can be adjusted to determine the maximum and minimum dimension of the mine entry in which the machine can be operated.

The illumination levels are determined by dividing the surfaces (face, roof, floor, and ribs) into square fields having areas of  $4\text{ft}^2$ . Incident light measurements are taken at the corners of each square by orienting the light sensor for a maximum reading. The average illumination for each square is determined by averaging the readings at its corners. The walls and the roof of the simulated entry are adjusted until the average illumination of each square field is at least  $2\text{fc}$ .

It is obvious that the method of evaluation is a time-consuming process. As a result, the Bureau of Mines awarded a contract to the

Mathematical Applications Group, Inc. (MAGI) for the development of a computer simulation program for evaluating coal mine illumination systems. MAGI has previously developed computer techniques for simulating three-dimensional geometric structures to analyze geometry-dependent physical properties. Therefore, the goal of the project was to incorporate these computer techniques into a system for accurately predicting coal mine illumination levels.

A program of this nature must be able to perform the following functions:

- a. Process a numerical model of a mining machine which is supplied as input.
- b. Accept a specification of the types and locations of illumination sources.
- c. Determine which luminaires contribute to the illumination at a specified set of points.
- d. Record the incident illumination levels at each detector point in an organized, easily interpreted format.

#### MACHINE MODELING TECHNIQUES

By experimentally determining the candlepower of a light source, one can easily predict the unobstructed illumination at a specific point by the Lambert cosine law:

$$E = \frac{I}{d^2} \cos \theta$$

This states that the illumination  $E$  is directly proportional to the candlepower  $I$  of the source and the cosine of the angle of incidence  $\theta$ , and inversely proportional to the square of the distance  $d$  between the source and the point. However, in order to accurately predict the illumination provided by a set of luminaires at any point in a mine entry, one must also account for the effects of shadowing due to the machine itself. Thus, an accurate representation of the mining machine must be created.

The mining machine is represented by a numerical model. The model is created by a "building block" approach in which basic predefined shapes (boxes, cylinders, cones, etc.) are combined according to prescribed rules to form more complicated objects. In constructing the model, each of these basic shapes is assigned specific dimensions and a location in a three-dimensional coordinate system. The totality of these forms then represents a complete numerical description of the desired model.

As an example, refer to Figure 1 for the construction of a simplified continuous miner model. The ripper head of the miner is modeled by a cylinder referred to as CYL 1. Its location is first defined by the  $x$ ,  $y$ ,

z coordinates at the center of either base. Thus, if the right base of the cylinder is chosen, its location would be defined by the point (4,1,1). The dimensions of the cylinder are then given by its axis vector and its radius. The axis vector is defined by the x y z coordinates, which give its magnitude and direction from the location point. Since the cylinder is 8 ft long with its axis parallel to the x axis in the negative direction, the axis vector is defined by (-8, 0, 0). The radius of the cylinder is 1 ft.

The cutter boom of the continuous miner is represented by a box, which is referred to as Box 2. It can be located by defining any corner of the box. If the corner indicated in Figure 1 is selected, its location is defined by the point (2.5, 3.5, 5). Its dimensions are then defined by three vectors which originate at the location point and give the magnitude and direction of the length, width, and height of the box. The length of the box is 2 ft in the negative y direction and 4 ft in the negative z direction. Thus, its length is defined by the coordinates (0, -2, -4). Since the box is 5 ft wide in the direction parallel to the negative x axis, its width is defined by the coordinates (-5, 0, 0). Similarly, the height of the box is defined by (0, -1, 0.5).

The main frame and the discharge boom of the machine are modeled by Box 3 and Box 4, respectively. These boxes are given locations and dimensions by the same method used for Box 2. Thus, the entire input to the program for the machine model of Figure 1 would consist of the following data:

```
CYL 1: Location = (4, 1, 1)
        Axis Vector = (-8, 0, 0)
        Radius = 1

BOX 2: Location = (2.5, 3.5, 5)
        Length = (0, -2, 4)
        Width = (-5, 0, 0)
        Height = (0, -1, 0.5)

BOX 3: Location = (3, 3.5, 17.5)
        Length = (0, 0, -12.5)
        Height = (0, -3.5, 0)

BOX 4: Location = (1, 3.5, 23.5)
        Length = (0, 0, -6)
        Width = (-2, 0, 0)
        Height = (0, -1, 0)
```

These data are read by the program and stored for the calculation phase. The accuracy of the machine model can be verified by generating a line drawing of the model on a video display. A detailed model of a continuous miner, which was generated by the numerical modeling process, is illustrated in figure 2.

## LUMINAIRE MEASUREMENTS

Experimental measurements must be made for a representative sample of each type of luminaire. These measurements determine the luminaires' iso-intensity characteristics in order to define an average luminaire for each type. The candlepower is determined as a function of the angular light distribution of the luminaire. This is accomplished by positioning a photometer at a fixed location and varying the orientation of the luminaire by the use of a goniometer. Some luminaires are equipped with a protective metal cage. The measurements are taken with the cage in place to account for its effects on the variation in light output. Incident light measurements (in foot-candles) are made for every 10 degrees of orientation, resulting in a spherical, latitude-longitude arrangement. These data are then reduced to define the candlepower of the luminaire for each angular location by

$$I = E d^2$$

where

E = incident light measurement (fc)

d = distance from the photometer to the luminaire (ft)

These data are then stored in a luminaire library.

## LUMINAIRE LOCATION AND ORIENTATION

Once the luminaire types are modeled and stored in the luminaire library, only the types of the luminaires desired and their locations and orientations on the machine need to be specified. Figure 3 shows two machine lights (Type 1) and two headlights (Type 2) mounted on the model of a continuous miner. The location of a luminaire is defined by x y z coordinates, using the same coordinate system utilized in the machine modeling process. Thus, the location of the center of luminaire 1 is defined by the point (-2.5, 3.75, 15.5). Each luminaire is assigned an aim and an axis vector which define its orientation on the machine. Since the axis vector of luminaire 1 is directed toward the face, parallel to the z axis in the negative direction, it is defined by the coordinates (0, 0, -1). Its aim vector is directed toward the roof parallel to the positive y axis; therefore, the aim vector is defined by the coordinates (0, 1, 0). The entire input that defines the locations and orientations of the four luminaires illustrated in Figure 3 would consist of the following:

LUM 1: Type = Type 1  
Location = (-2.5, 3.75, 15.5)  
Aim = (0, 1, 0)  
Axis = (0, 0, -1)

LUM 2: Type = Type 2  
Location = (-2, 3.75, 7)  
Aim = (0, 0, -1)  
Axis = (0, 0, -1)

LUM 3: Type = Type 1  
 Location = (2.5, 3.75, 15.5)  
 Aim = (0, 1, 0)  
 Axis = (0, 0, -1)

LUM 4: Type = Type 2  
 Location = (2, 3.75, 7)  
 Aim = (0, 0, -1)  
 Axis = (0, 0, -1)

The location of the luminaires can also be defined by an alternate method. This requires displaying the machine model on the graphics terminal and using movable crosshairs to define the luminaire's position on the model. However, the aim and the axis vectors must still be defined.

Prior to starting the illumination calculations, the program determines the validity of the locations of the luminaires. It tests whether any point on the axis of each luminaire lies outside the mine entry or inside any geometric shape comprising the machine model. If either case occurs, the luminaire has been improperly located, and the program is terminated.

It should also be noted that high-intensity discharge lamps and incandescent lamps can be treated as point emitters owing to their compact sources of illumination. However, the point source approximation for fluorescent luminaires becomes invalid owing to the length of the arc tube. Therefore, the program automatically divides the tube into smaller segments and treats such segment as a point emitter.

#### ILLUMINATION CALCULATIONS

Once the luminaires are positioned on the machine model and the dimensions of the mine entry are specified, the illumination calculations begin. As an example, assume three luminaires located on a model of a continuous miner and a detector point D located on the right rib, as illustrated in figure 4a. The calculations proceed in the following manner:

(1) The distance  $d$  from luminaire 1 to the detector point D is calculated by

$$d_1 = (x_1 - x_D)^2 + (y_1 - y_D)^2 + (z_1 - z_D)^2$$

where  $x_1, y_1, z_1$  are the coordinates that define the location of luminaire 1 and  $x_D, y_D, z_D$  are the coordinates that define the location of the detector point. The distances  $d_2$  and  $d_3$  are then determined in a similar fashion.

(2) Since the location of the luminaires with respect to the detector point is known, the candlepowers ( $I_1, I_2,$  and  $I_3$ ) of the luminaires are determined from the prestored angular distribution data.

(3) The program tests whether the candlepower of any luminaire is equal to zero; if so, the illumination contribution  $E$  of the luminaire is assigned the value of zero. If the candlepower of the luminaire is greater than zero, the illumination contribution of the luminaire is calculated ignoring the cosine correction, by

$$E = \frac{I}{d^2}$$

Since luminaire 3 is a headlight which is oriented toward the face, the detector point  $D$  does not lie within the angular distribution pattern of the light as shown in figure 4b. Thus, the prestored angular distribution tables would contain the value of zero for luminaire 3 in this particular situation. Therefore,  $E_3$  is assigned the value of zero. Since point  $D$  is within the angular distribution patterns of luminaires 1 and 2, the illumination contribution of each luminaire is calculated as follows:

$$E_1 = \frac{I_1}{d_1^2} \text{ and } E_2 = \frac{I_2}{d_2^2}$$

(4) To determine the possible effects of machine shadowing, a ray tracing is performed for each luminaire whose illumination contribution  $E$  is greater than zero. A ray is traced from the location point of each applicable luminaire to the detector point. If a ray intersects any component of the machine model, the contribution of the luminaire is assigned the value of zero. Thus from figure 4c,  $E_1$  is set equal to zero.

(5) As mentioned earlier, the present method of measurement requires the use of a cosine-corrected photometer. These measurements are made by orienting the probe in a trial and error fashion until the maximum reading is obtained. The reading thus displays the summation of the illumination contributions of each luminaire, taking into account the cosine of their angles of incidence.

To duplicate this procedure, the detector point  $D$  is surrounded by an imaginary hemisphere which is divided into degrees of latitude and longitude. Each pair of angles determines a possible orientation of the axis of the detector probe. For a given axis direction, the program computes the angle of incidence  $\theta$  for each luminaire and the following quantity:

$$E_D = \sum_n E_n \cos \theta_n$$

This procedure is repeated for each latitude-longitude pair, which results in approximately 200 orientations being tested. Thus, the program scans through a series of angles as shown in figure 4d. For the sake of simplicity, the diagram is illustrated in a two-dimensional mode. Since luminaire 2 is the only luminaire that contributes to the illumination at the detector point  $D$ , the maximum reading is obtained with the

normal of the probe aimed directly at this luminaire. Therefore, the angle of incidence is equal to zero, and the maximum illumination at point D is equal to  $E_2$ .

After all the detector points on a given entry surface have been completed, the averages within each 2-ft by 2-ft square are computed and the entire matrix of results is printed. The program then repeats the entire process until all five entry surfaces have been covered. The output format for a 6-ft-high by 12-ft-wide coal face is illustrated in figure 5. Any average illumination level that falls below the required level of 2 fc is flagged with an asterisk for easy identification.

## RESULTS

To verify the accuracy of the illumination calculations, simple structures were mocked up, consisting of cardboard boxes placed on the floor of a simulated mine entry. Readings were taken on a 2-ft by 2-ft grid to coincide with the computer output pattern. The computed results from one of these tests are shown in figure 6. The calculations were in good agreement with the experimental readings, with differences generally less than 8 percent. A few scattered locations, especially those at low illumination levels, showed larger differences. Other tests at MSHA's Illumination Laboratory produced similar results.

Experimental measurements for the various types of luminaires have shown that their deviations from the average light output can vary as much as 10 percent. Thus, the computer simulation provides a more standard means of evaluation than present methods, since the average light output for each type of luminaire is used for the calculations.

The computer simulation program will significantly decrease the time involved with the present method of evaluating mine illumination systems. Computer-generated models of mining equipment, with sufficient detail to produce accurate results, can be created in approximately 2 hours, as opposed to 8 hours for the construction of a less detailed machine mockup. The numerical models can be stored indefinitely and retrieved as needed for future evaluations, whereas a mockup must be constructed for each different evaluation owing to storage and material limitations. Modifications to existing models (the addition or removal of a canopy, etc.) can be accomplished without having to recreate a new model.

## CONCLUSION

The computer simulation program described should be a viable alternative to experimental measurements for evaluating mine illumination systems. Once the machine is numerically modeled and the characteristics of the desired luminaires are determined, the user need only specify the locations and orientations of the luminaires on the model to accurately predict the incident light levels on all mine surfaces. The program accounts for the effects of shadowing by tracing simulated light rays from each luminaire to an array of detector points, and the output of the illumination levels is recorded in an organized and easily interpreted format.

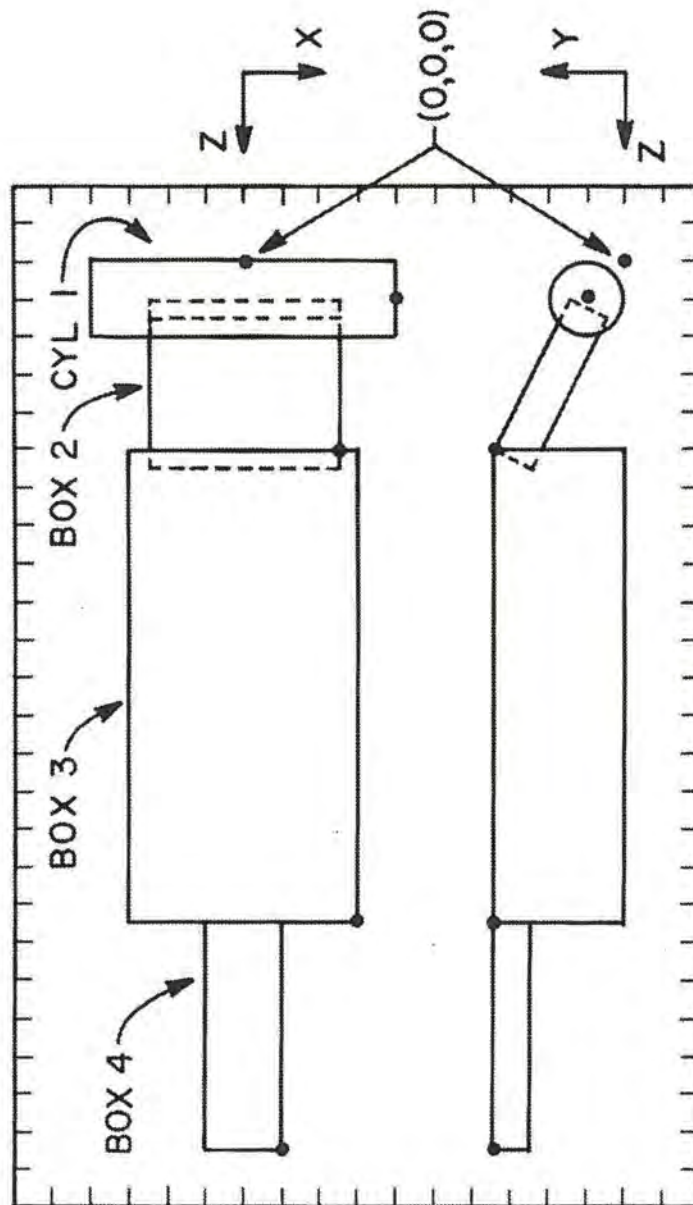

FIGURE 1.--Simplified model of a continuous miner

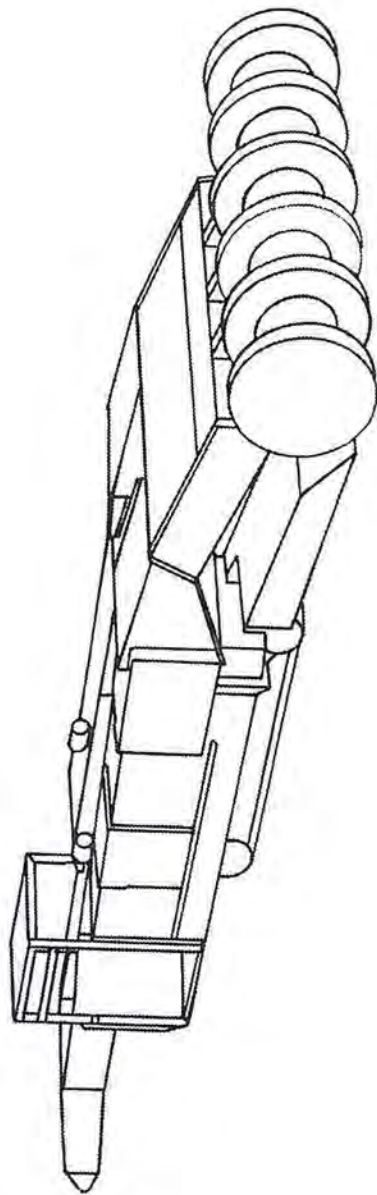

FIGURE 2.--Actual computer generated line drawing of a continuous miner

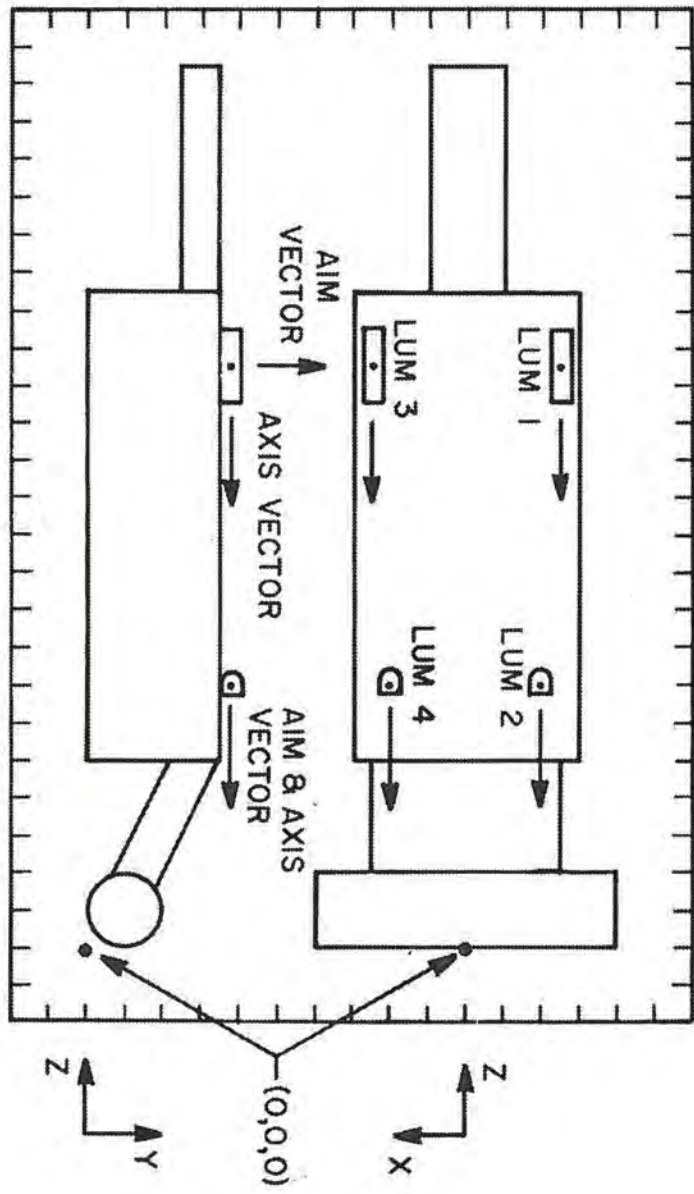

FIGURE 3.--Location of luminaires on the machine mockup

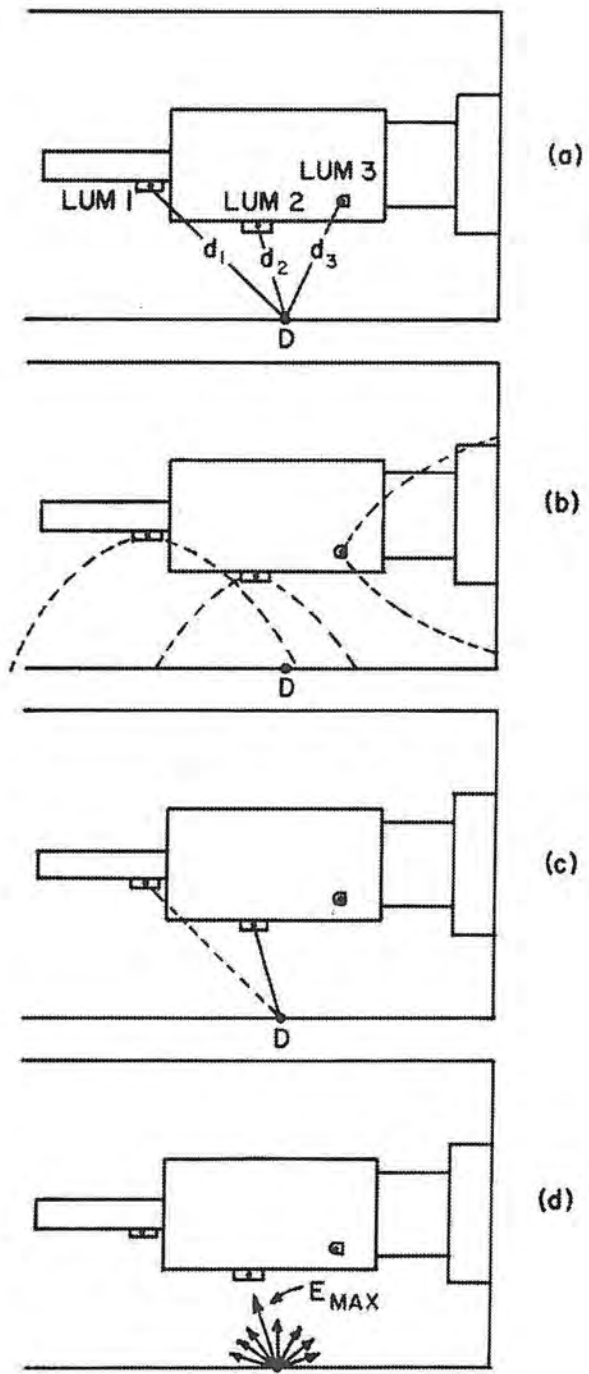
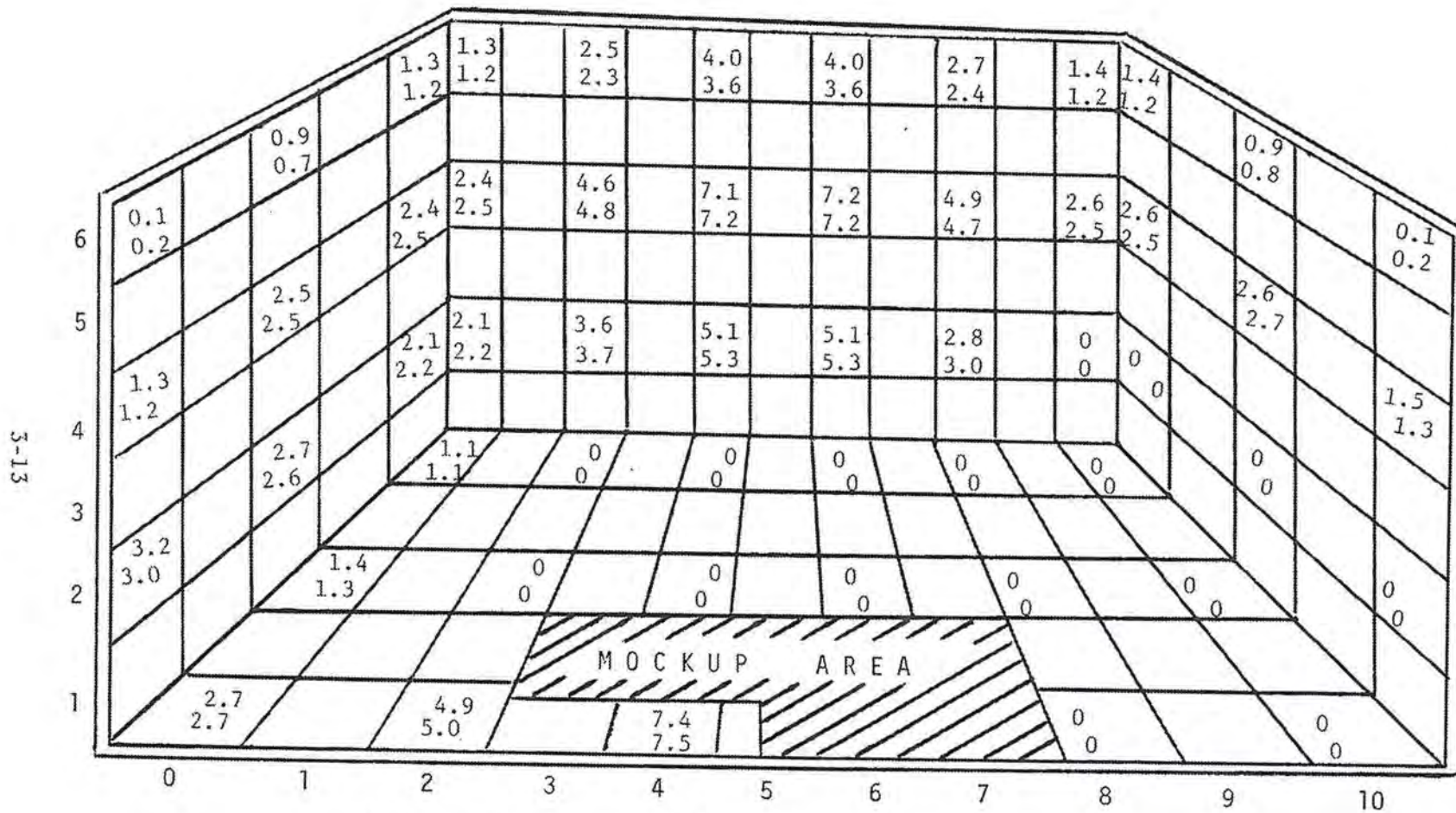

FIGURE 4.--Illumination calculations

F A C E

	0	2	4	6	8	10	12
	1.0	1.2	2.8	4.8	2.7	1.1	1.1
Avg.	1.2*	2.1	3.9	3.9	2.0	1.2*	
	1.2	1.4	3.0	5.0	2.9	1.4	1.3
Avg.	1.4*	2.3	4.2	4.2	2.2	1.4*	
	1.4	1.5	3.2	5.6	3.1	1.4	1.5
Avg.	1.3*	2.3	4.2	4.1	2.2	1.3*	
	1.0	1.3	3.0	4.9	2.9	1.3	1.1

FIGURE 5.--Output format



Upper number is computed (fc); lower number is measured (fc)

FIGURE 6.--Calculated and measured results

MINE POWER SYSTEMS I

MINE POWER SYSTEMS II

MINE INSTRUMENTATION

West Virginia  
University

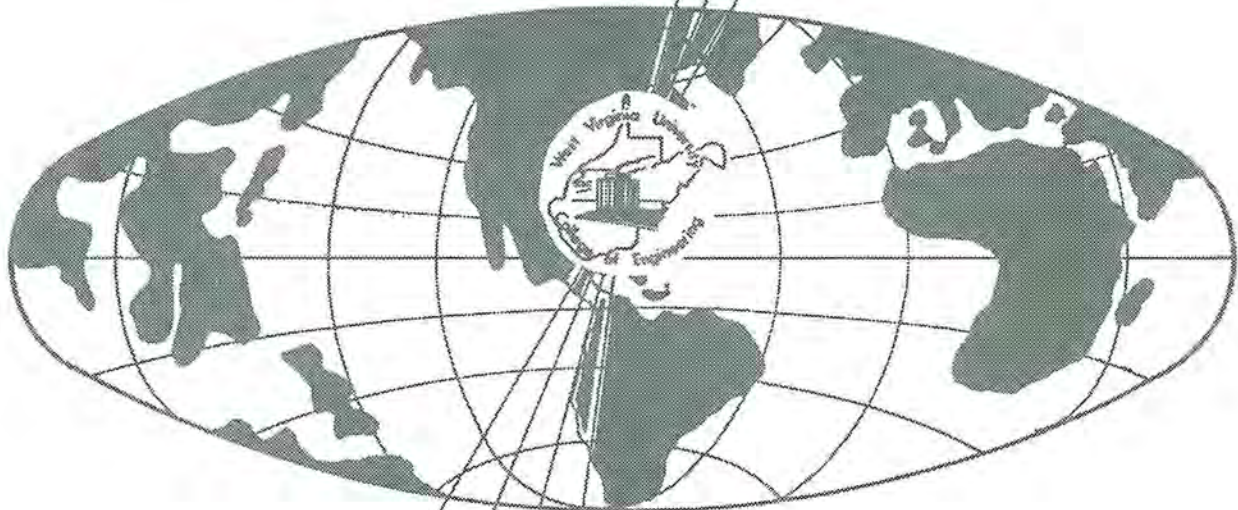

MINE ILLUMINATION

MINE COMMUNICATIONS

POWER INSTRUMENTATION

AUTOMATIC CONTROL AND MONITORING

Proceedings of  
THE FOURTH WVU CONFERENCE  
ON COAL MINE ELECTROTECHNOLOGY  
August 2-4, 1978

PROCEEDINGS  
OF THE  
FOURTH WVU CONFERENCE  
ON COAL MINE  
ELECTROTECHNOLOGY

AUGUST 2-4, 1978

LAKEVIEW INN AND COUNTRY CLUB  
NEAR  
MORGANTOWN, WEST VIRGINIA

SPONSORED BY

WEST VIRGINIA UNIVERSITY  
COLLEGE OF ENGINEERING  
DEPARTMENT OF ELECTRICAL ENGINEERING  
AND  
MINING INDUSTRY COMMITTEE  
IEEE INDUSTRIAL APPLICATIONS SOCIETY



AND  
U.S. BUREAU OF MINES  
IN COOPERATION WITH  
DEPARTMENT OF ENERGY  
AND  
MINE SAFETY AND HEALTH ADMINISTRATION

1. Report No.	2.	3. Recipient's Accession No.	
4. Title and Subtitle Proceedings of the Fourth WVU Conference on Coal Mine Electrotechnology		5. Report Date October 1, 1978	6.
7. Author(s) M. Dayne Aldridge, Editor		8. Performing Organization Report No.	
9. Performing Organization Name and Address Department of Electrical Engineering West Virginia University Engineering Sciences Building, 8th Floor Morgantown, WV 26506		10. Project/Task/Work Unit No.	11. Contract or Grant No. Purchase Order No. J0188034
12. Sponsoring Organization Name and Address U.S. Bureau of Mines Pittsburgh Mining and Safety Research Center 4800 Forbes Avenue Pittsburgh, PA 15213		13. Type of Report Final Report	
15. Supplementary Notes		14.	
16. Abstract  A compilation of papers presented at the Fourth WVU Conference on Coal Mine Electrotechnology in Morgantown, West Virginia, on August 2-4, 1978. Papers cover areas of electric power, electronic communications, detection and location of trapped miners, and electronic sensors and monitoring systems.			
17. Originator's Key Words Mining, Mine Fires, Mine Gases, Mine Ventilation, Safety, Underground Explosions, Sensors, Monitoring, Data Systems, Data Processing, Electronic Instruments		18. Availability Statement  Release Unlimited	
19. U. S. Security Classif. of the Report Unclassified	20. U. S. Security Classif. of This Page Unclassified	21. No. of Pages 521	22. Price