

Using Ventilation Control Technology to Reduce Respirable Dust Exposures at US Metal/Non-Metal Mining Operations

A B Cecala¹, J A Zimmer¹, J F Colinet¹, R J Timko¹, G J Chekan¹ and D E Pollock¹

ABSTRACT

It has long been known that ventilation is a cost-effective method to lower respirable dust concentrations in all types of mining applications. The National Institute for Occupational Safety and Health has been working on a number of different research techniques that use ventilation as a critical component to lower respirable dust levels at surface and metal/non-metal operations in the United States. This article presents five such research efforts. The first research area discusses how improving the ventilation flow patterns in an iron ore mill facility lowered respirable dust concentrations by 31 per cent throughout the primary grinding area. The second research area examines how respirable dust levels were lowered at a dimensional stone shop by using air cleaning units suspended from the ceiling. A third area discusses how improvements in ventilation at underground limestone mines lowered respirable dust concentrations. The fourth area examines how improvements in dust filtration and pressurisation systems significantly impacted the air quality in enclosed cabs of surface mining equipment. The last area presents a newly developed clothes cleaning technique. This technique uses an air spray manifold to blow dust from a worker's clothing in an enclosed booth, which confines the dust for capture and removal by a baghouse dust collector. These research areas represent an array of different control technologies to lower respirable dust concentrations. Ventilation is an integral part of these control technologies.

INTRODUCTION

The effective use of ventilation has long been known as a critical component for the mining industry. Fundamentally, ventilation is aimed at providing sufficient airflow throughout underground mining operations. Providing clean air to miners while diluting and removing contaminants and gases from working faces in underground mines is a critical function of ventilation; ventilation can also provide however, a vast array of other useful functions in the mining industry.

Reducing respirable dust exposures to workers is a constant goal throughout the mining industry, and various applications of ventilation techniques can be a major contributor toward reaching this goal. When engineers and health and safety specialists investigate methods and techniques to lower dust levels in surface and metal/non-metal operations, such control measures as water sprays, surfactants, dust collection systems, cyclones, and electrostatic precipitators usually come to mind. Ventilation should also be viewed as a useful technique to improve air quality and lower respirable dust exposure in these types of operations.

One benefit with the use of ventilation is that many times it encompasses an entire structure and thus has the potential to lower exposures to numerous workers. One such example was a study performed by the Bureau of Mines a number of years ago regarding the use of total mill ventilation systems, emphasising the need for an effective ventilation flow pattern in mineral processing operations (Cecala *et al*, 1993). The goal of a total mill ventilation system is to bring clean makeup air in at the base of a structure and draw this air up through the building, clearing major dust areas as air flows towards the top of the structure. This dust-laden air is then exhausted from the top of the walls or at the roof of the structure.

During this research study, average respirable dust levels were reduced by 40 and 64 per cent at two field evaluation sites. These significant reductions were achieved throughout the entire structure with only a relatively minor amount of ventilation air added in reference to the size of the structure. The targeted air quantity necessary for this total mill ventilation system is at least ten air changes per hour. This technique is believed to be the most cost-effective method to lower respirable dust concentrations throughout an entire mineral processing structure, and it demonstrates the impact that ventilation can have at these types of facilities.

This manuscript will discuss five different research studies conducted by the National Institute for Occupational Safety and Health (NIOSH) which use ventilation in some application to lower workers' respirable dust exposures at surface and metal/non-metal mining operations. As federal standards for health issues continue to require lower levels in the future, engineers and health and safety specialists must investigate novel approaches to improve air quality. The goal of the research discussed in this manuscript is to provide an array of applications where ventilation can be used to reduce respirable dust exposures.

FIVE RESEARCH STUDIES USING VENTILATION TO LOWER RESPIRABLE DUST LEVELS

Improving ventilation at an iron ore processing plant

Through a cooperative work effort between the Tilden Mining Company LC, the United Steelworkers of America, and NIOSH, a number of studies have been performed over the past three years in an effort to lower respirable dust levels at these processing facilities. We will limit our discussion in this research area to an evaluation performed in March 2004 examining the impact of ventilation changes on the air quality at the Tilden iron ore facility. This facility was located near Ishpeming, Michigan, and was a 26 600 m² structure with an internal air volume of 1 273 500 m³. Initially, a number of different approaches and techniques were investigated, but as time progressed, it became evident that the most substantial impact on lowering respirable dust levels could be achieved through improvements in the ventilation flow pattern within a structure. This was achieved by changing the quantity of air that entered and was exhausted from the structure. Ventilation at this operation was performed by using roof-mounted fans in either the intake or exhaust mode, which is common throughout the iron ore industry.

During the first day of testing, the operation's normal ventilation setup was evaluated. Figure 1 shows a summary of this ventilation setup with the exhaust fans indicated by arrows exiting and intake fans indicated as arrows entering the structure. To evaluate this original ventilation design, the structure was broken down into three distinct areas: primary grinding (northern-most portion), secondary grinding with pebble mills, and filtering and flotation (southern-most portion). Respirable dust samplers were located in these three areas, with the greatest focus being on the primary grinding mills. The only other mechanical ventilation provided was from two intake heater fans located at the base of the facility, one located on the east and the

1. National Institute for Occupational Safety and Health (NIOSH), Pittsburgh Research Laboratory, PO Box 18070, Pittsburgh PA 15236, USA.

other on the west side of the building. The volume of air being exhausted from the structure was 54 700 m³/min, as compared to 17 000 m³/min being brought into the structure. These ventilation air volumes were calculated based upon the values provided by the facility and the assumption that all the fans were operating at their rated output. The two intake heater fans accounted for 12 800 m³/min, or 75 per cent of the total intake airflow. Dust sampling under this ventilation setup was performed for approximately 20 hours of testing.

The imbalance between the intake and exhaust air volumes with this ventilation setup was substantial; therefore it was decided to modify the ventilation to a more balanced design. It should be noted that although the goal was to lower respirable dust concentrations throughout the entire facility, the main priority was to lower respirable dust concentrations in the primary grinding area. Dust levels in the primary grinding area were higher than in the other areas because of the amount of dust liberated from the numerous conveyor lines feeding the primary grinding mills, as well as the amount of dust being liberated from the mills themselves. In an effort to focus on this area, a ventilation change was initiated as shown in Figure 2. The two intake heater fans were again used to bring a significant portion of intake air into the facility. For this modified design, there were 11 exhaust fans operating in the primary grinding area, 12 intake fans in the secondary grinding area, and eight exhaust fans operating in the filtering and flotation area. The volume of air being exhausted from the structure was approximately 26 600 m³/min, with approximately 29 600 m³/min brought into the structure through the roof intake fans and two heater fans. This ventilation design was again tested for approximately 20 hours.

During this phase of testing, a smoke flare was released into one of the intake fans over the pebble mill. Since properly operating intake fans should move an air parcel ten fan diameters before being reduced to ten per cent of the fan's air velocity, the roof-mounted fans should introduce a parcel of air into the lower parts of the building (Industrial Ventilation, 2001). These roof-mounted fans are all 1.2 m in diameter and should introduce a slug of air at least 12 to 15 m into the structure. Since this testing was performed during the winter months, introducing cold outside air into the structure should also assist the air parcel's ability to flow down into the lower levels of the structure. From visual observations during this smoke flare release, it appeared that the intake fan chosen for this testing was not operating at the calculated airflow. The smoke remained within the top one-quarter of the structure and tended to drift towards the southern portion of the building (toward the flotation and filtration area). As test personnel walked through the secondary grinding area, it was very difficult to feel the intake air being delivered into the structure by the intake fans. Since the walkway was only 9.1 m below the intake fans, airflow should have been perceivable at this level.

Since the intake air appeared to be drifting towards the flotation and filtration area, it was decided to modify the ventilation setup again in an attempt to provide a greater quantity of the intake air moving in the northern direction towards the primary grinding mills. Figure 3 indicates the second modification to the ventilation design which was evaluated for approximately eight hours during the last day of testing. This ventilation setup was composed of 24 exhaust fans and 12 intake fans, along with two base heater intake fans. The volume of air exhausted from the structure was approximately 32 000 m³/min, with 29 600 m³/min being brought into the structure through the roof intake fans and two base heater fans. The amount of intake air was identical to the previous test, but the exhaust was changed in an attempt to decrease the flow toward the flotation and filtration area while increasing the airflow to the primary grinding mill area.

Table 1 shows the average respirable dust concentration as determined by the instantaneous respirable dust monitors used in this study and provides a comparison of the three different ventilation designs tested. Obviously, the last ventilation design was the most effective at lowering respirable dust levels, particularly in the primary grinding area, which was the main area of emphasis. When compared to the first two ventilation designs, this ventilation design lowered respirable dust concentrations in the primary grinding area by 31 and 25 per cent, respectively. This is a very significant reduction when one considers it was achieved by using the existing fans and simply varying the intake and exhaust flow patterns. Respirable dust levels were also slightly lower in the pebble mill and the flotation and filtration areas with the last ventilation setup. This study indicates the impact that ventilation can have to lower respirable dust levels throughout a large-volume iron ore processing structure.

TABLE 1
Average respirable dust concentrations in mg/m³ for three ventilation setups.

Location	Setup #1 Day	Setup #1 Night	Setup #2 Day	Setup #2 Night	Setup #3 Day
Primary #2	1.06	1.21	0.66	0.38	0.44
Primary #4	0.72	0.70	0.59	0.59	0.45
Primary #6	1.15	1.34	1.37	1.49	0.98
Primary #8	1.23	1.34	1.18	1.23	0.86
Primary #10	-	0.97	1.05	0.91	0.72
Primary #12	0.67	0.72	0.79	0.88	0.75
Average	0.97	1.05	0.94	0.91	0.72
Pebble #1	0.32	0.38	0.38	0.31	0.29
Pebble #3	0.42	0.42	0.47	0.51	0.42
Pebble #6	0.34	0.35	0.48	0.50	0.35
Pebble #9	0.49	0.50	0.51	0.56	0.49
Pebble #12	0.38	0.41	0.36	0.43	0.38
Average	0.39	0.41	0.44	0.46	0.38
Flotation #3	0.25	0.32	0.35	0.34	0.24
Flotation #9	0.27	0.34	0.45	0.40	0.31
Average	0.26	0.33	0.40	0.37	0.27

Air cleaner units at dimensional stone operation

This study evaluated small air cleaning units suspended from the ceiling at a dimensional stone operation. These units were installed to reduce respirable dust levels to workers during the winter months. Dimensional stone operations sell a variety of products for decorative applications, as well as a vast array of tabletops and countertops. After the stone is removed from quarries in large blocks and slabs, it is cut using various sized saws to fabricate the numerous products. Although the actual stone type varies from operation to operation, much of this dimensional stone contains silica-bearing material, which makes the dust generated during the cutting and shaping even more hazardous to the workers. During warm temperatures, the shop doors where this stone cutting takes place are open to the outside atmosphere, which provides natural ventilation to dilute the dust generated. During cold weather, these doors are closed to maintain acceptable work temperatures for employees and to keep water lines from freezing. This causes dust levels to significantly increase.

To lower respirable dust levels during the winter season, one operation installed a number of small air cleaning units that were suspended from the ceiling. NIOSH was evaluating ways to

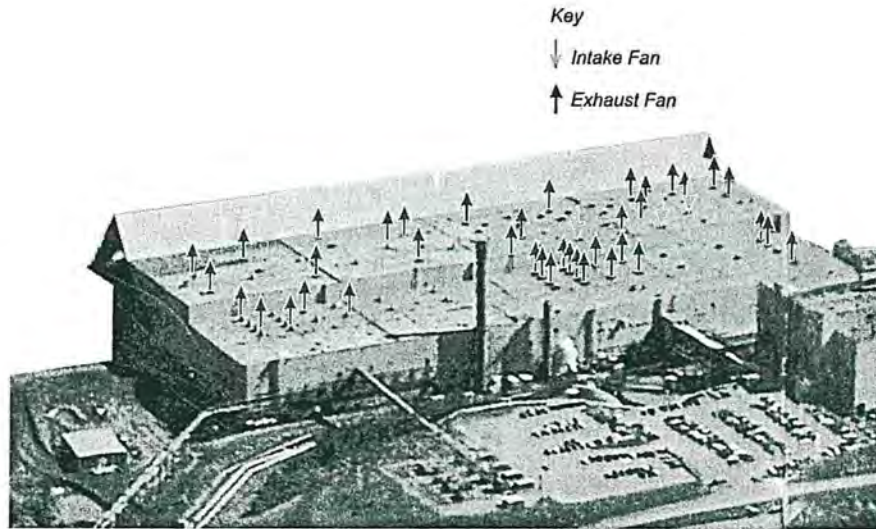

FIG 1 - Baseline or normal ventilation setup.

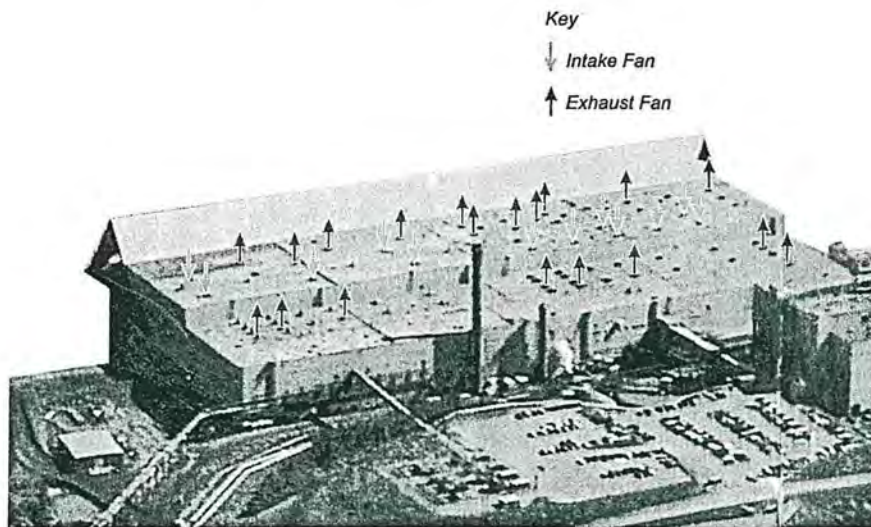

FIG 2 - Ventilation setup #2.

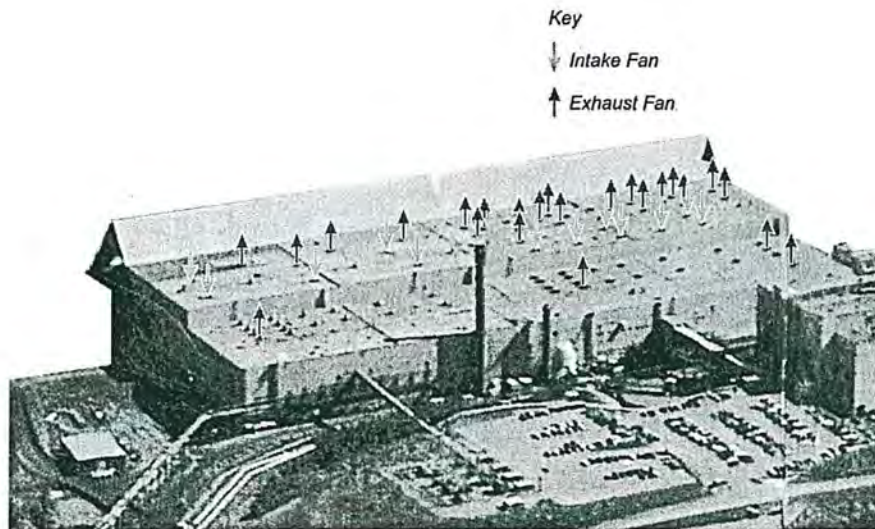

FIG 3 - Ventilation setup #3.

lower respirable dust levels in these types of operations and one part of this study was to determine the effectiveness of these small air cleaner units. The stone being processed at this operation had an 85 - 90 per cent silica content.

The air cleaning units were positioned in and around one particular processing shop. These units were designed to take 57 m³/min of dust-laden air from within the facility, filter it and then return it to the shop area. These units were rectangular shaped boxes that housed two filters, a pre-filter and final (high efficiency) filter.

On the first day of testing at this operation, respirable dust levels were evaluated in the process shop area with the existing filters in the air cleaner units. Plant management stated that the filters on the cleaning units had been in use for three to four months. During this testing, air velocity measurements were taken with a vane anemometer, indicating that only a minimal amount of airflow was being cleaned through these units. The air volume in each of the six units was below 14 m³/min and it appeared that the units were not able to handle the additional pressure created by the dust loading on the filters. Figure 4 shows the six different dust sampling locations along with the location of the six air cleaner units. These sampling locations provided a profile of respirable dust levels throughout the entire processing shop area. This figure also indicates the location of the shop machinery: a computerised saw, a polisher machine, and a chop saw.

After this initial day of testing, new pre-filters and final filters were installed into six air cleaning units. The objective was to determine the maximum air cleaning potential of the units with new filters and to compare the results to those achieved with the filters that had three to four months of use. Once all new filters were installed, the identical dust measurements were again performed for the second day of testing. Airflow measurements were then taken on a number of air cleaning units to determine the airflow quantity with the new pre-filters and final filters. Periodically throughout the day, additional airflow measurements were taken to determine relative changes. From these measurements, it was determined that as the filters loaded with dust and the pressure differential across the filters increased, there was a drastic decrease in the air quantity flowing through the unit.

Figure 5 indicates the average respirable dust concentration obtained with the instantaneous dust monitors at the six sample locations for this study. With the new filters, there was a 48 per cent reduction in respirable dust levels when compared to the filters with three to four months of use. Based on the results of this study, it appears that the increased airflow through the air cleaning units was the major factor in reducing respirable dust concentrations in the processing shop. In an effort to verify this, a series of airflow measurements were taken on the discharge port of two of the air cleaner units. For the first day of testing with the used filters, the air volume was determined to be 8.5 m³/min. When the used filters were removed, the unit delivered 73 m³/min. After new filters were installed, the airflow was reduced to 55 m³/min, which is within 2.5 per cent of the rated output of the unit. After a full day of testing with the new filters (day two), a 20 per cent loss in airflow was determined with a resulting air volume of 44 m³/min. At the end of the second day of testing with the new air filters (day three), there was a 57 per cent loss in airflow with a resulting air volume of 24.8 m³/min. After two more days, or the fourth day of using the new filters, the air volume was reduced by 77 per cent to an air volume of 12.7 m³/min. The manufacturer of the air cleaner unit was contacted and informed of the problem of reduced air flow through the unit as the filters loaded with dust. A modification to the unit is being considered at the present time. An improved blower that is able to handle the increased pressure without the drastic fall-off in air flow is also currently being evaluated.

Although these results were disappointing based on the rapid decline in air volume with filter use, this testing indicated the potential these air cleaning units could have to improve the air quality in dimensional stone processing shops, especially through the winter months when the shops are closed. As previously stated, there was a 48 per cent reduction in respirable dust concentrations when new filters were used in the air cleaning units and they were able to clean and deliver their rated volume of air. The individuals working in the processing shop indicated that they were able to see a noticeable change in the air quality at this level. This work also indicated how some technology ultimately does not supply the intended level of

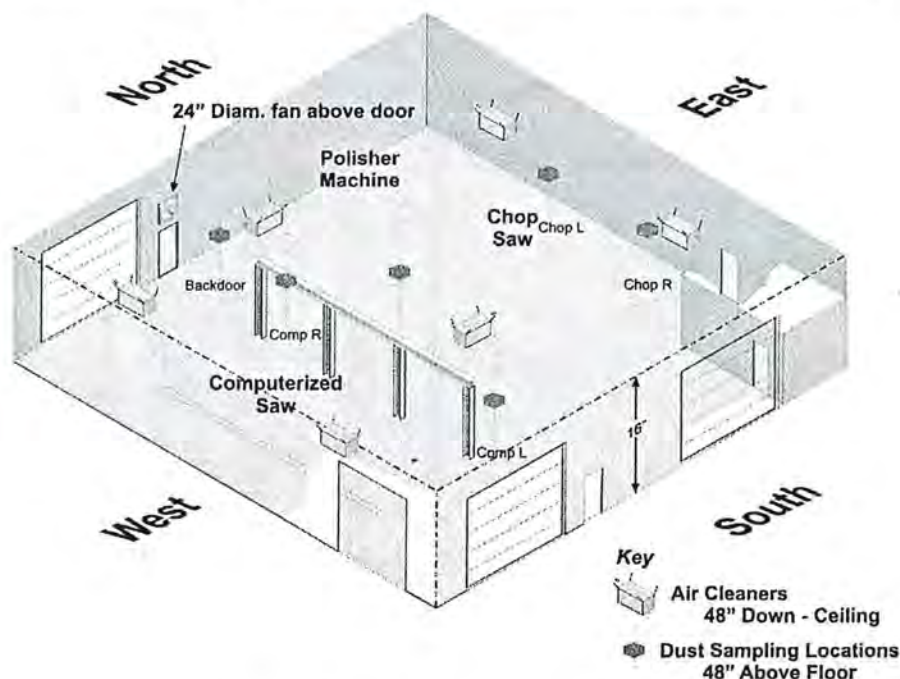

FIG 4 - Air cleaner units and dust sampling locations.

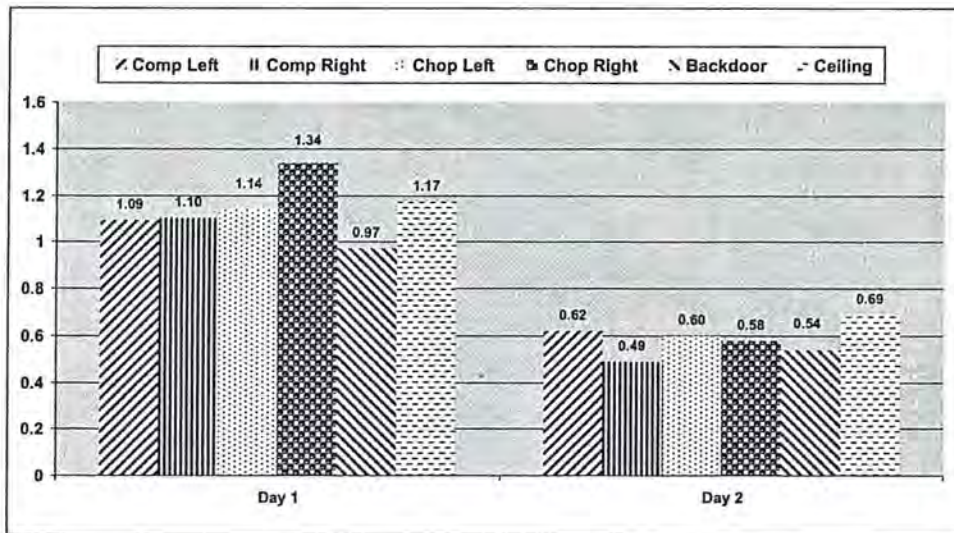

FIG 5 - Respirable dust concentrations in mg/m^3 for filters that had been in operation for three to four months (day one) and new filters (day two) on six air cleaning units.

protection. The dimensional stone operation had good intentions when it purchased these units to improve the air quality in its processing shop. The operation was unaware that the air cleaner unit performance decreased drastically after minimal dust loading and only provided a minimal improvement to the air quality for a relatively short time period. These air cleaner units were not designed to handle the level of dust encountered in these types of dimensional stone operations. In working with the manufacturer, we are hoping that the units can be modified with an improved blower that is able to handle the pressure drop from the dust loading on the filters and will provide a more reasonable time period before the filters need to be cleaned or changed.

Evaluating ventilating air movement in underground limestone mines

Underground limestone mines typically have large entries, ranging in cross-sectional areas from 46 to 223 m^2 . Air quantities flowing through these large-opening entries result in low velocities, typically less than 0.13 m/s. Because of the low air velocities, the air may become stratified and readily affected by seasonal patterns in natural ventilation. In addition, limestone mines may have minimal or no mechanical ventilation and often do not have stopping lines to control air movement throughout the mine. Consequently, it can be difficult to measure air velocities and define airflow patterns by using conventional airflow measuring equipment.

A research effort was performed to evaluate air movement and flow patterns in underground limestone mines by measuring respirable dust levels generated from production shots. Production shots generate a considerable volume of respirable dust and serve as a distinctive point source of dust. In this study, respirable dust was monitored with an instrument that uses light-scattering technology to log dust concentrations in real-time. Respirable dust ($<10 \mu m$) that becomes airborne after the shot can remain entrained in the air at very low velocities. This 'dust cloud' moves with the general airflow pattern in the mine and the dust monitor records the dust concentration, generating a time-dependent curve. The shape of the curve is directly related to the distance of the monitor from the production shot. As the distance between shot and dust monitor increases, the time interval for measurable dust increases but the peak concentration becomes less. Multiple shots in the same location create a dust cloud that is easily distinguishable. This sampling also identified the length of time that was needed for the ventilation in each mine to clear the dust

from the mines after the shots. The original study involved a number of different limestone mines; however only one example will be presented in this report to show the applicability of this technique to evaluate ventilation flow patterns in large-opening mines (Chekan *et al*, 2004).

Figure 6 shows the mine workings and ventilation setup. The mine originally relied solely on natural ventilation without the assistance of booster fans. Airflow to the faces, especially in the northern and southern areas of the mine, was minimal and air velocity and direction were difficult to characterise with anemometer or smoke tube measurements. Dust from shots tended to migrate through the mine with little directional flow.

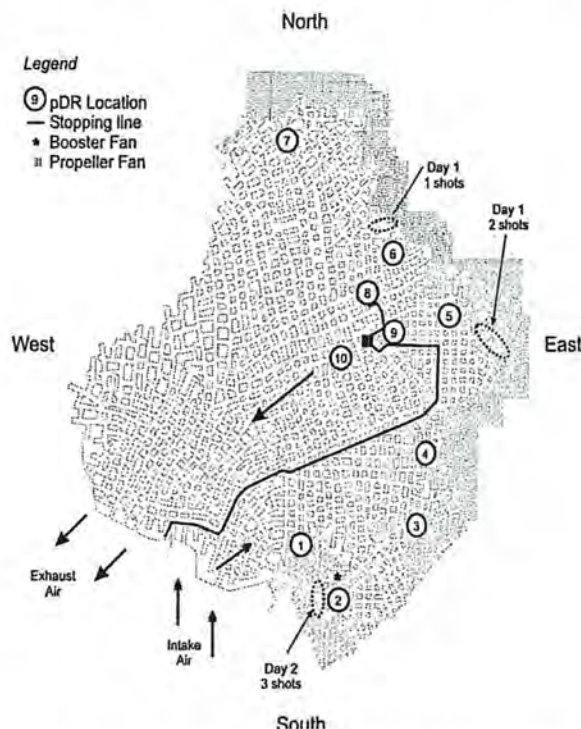

FIG 6 - Mine workings for case study, showing location of dust monitors, curtain line, and fans.

Mine management eventually began a more systematic approach to mining, as shown in the future developments projections. These projections required that some extensive rehabilitation work be performed, which included major upgrades in the ventilation system to improve airflow at the faces. This ventilation upgrade included:

1. two Hartzell Series 10S, 3.66 m diameter, high- volume, low-pressure propeller fans each rated at 212 m³/s, which established a directional airflow from the southern portals to the fan;
2. a Spendrup Model 1000-50-26H, 1.37 m diameter axial vane booster fan rated at 92.7 kW and 42.4 m³/s, which provided localised ventilation to the working faces; and
3. the installation of approximately 50 curtain stoppings on the southern and eastern side of the mine to provide improved airflow to the active faces.

Owing to the vast workings and the need to provide sufficient air to the new working faces, the two propeller fans were installed inside the mine, rather than at the portal (typical location). On the exhaust side of the fan was a large abandoned benched area. The plan was to dump the exhaust air into this area, where the dust would dilute and eventually exit the mine at portals to the west.

The study was conducted after the new ventilation system installation had been completed. The dust monitoring locations chosen for this study were based on smoke tube measurement testing, resulting in locations near faces and also spaced to cover areas of interest where the airflow was consistent.

Table 2 summarises the results of the dust surveys for the two days of sampling. Shown in the table are the:

1. number of shots for each sampling day;
2. station number;
3. station distance from the shot;
4. peak and average concentrations; and
5. elapsed time needed for the dust cloud to arrive, the time of peak concentration, and the time to the end of the dust cloud.

The three shots on day one were designed to monitor the movement of dust from nearby faces located east of the fan and determine if the ventilation was sufficient to prevent the dust from migrating to other areas of the mine. One shot was located near station 6 and 2 shots were located near station 5. The location and time spacing of shots (the first shot near station 6 was four minutes before the two simultaneous shots near station 5) provided two different signatures on the dust monitors. The dust monitors showed that dust from the first shot migrated past station 6 to station 8, then to station 9 at the fan. Dust from the next two simultaneous shots migrated past station 5, then to station 9 at the fan. The dust monitor at station 9 (fan) showed only one peak value, indicating that the dust from the different shot locations merged and reached the fan at approximately the same time.

Since dust was recorded at station 8, some dust was obviously passing the fans. The lower velocity of 0.18 m/s, lower peak value, and longer duration of the dust cloud in comparison to the other stations all indicate however, that most of the dust from all three shots made a direct path to the fans. Station 10, located approximately 152 m from the fan on the exhaust side, showed that velocities remained high but dilution was occurring, as

TABLE 2
Estimated velocity of dust cloud for case study.

Station	Day 1 - 3 shots						
	Approximate distance from shot (m)	Peak conc (mg/m ³)	Average conc (mg/m ³)	Arrival time (min)	Peak time (min)	End time (min)	Estimated average velocity (m/s)
6	61.0	7.9	1.4	1.2	6.8	152.8	0.34
8	260.0	3.2	1.2	12.8	25.0	211.7	0.18
5	198.0	22.2	3.4	4.5	8.0	66.2	0.31
9 - Fan	365.8	13.2	3.5	10.3	18.0	74.2	0.34
10	579.1	4.0	1.8	13.3	27.0	198.5	0.38
1	No dust recorded from shots						
2	No dust recorded from shots						
3	No dust recorded from shots						
4	No dust recorded from shots						
7	No dust recorded from shots						
	Day 2 - 3 shots						
2	122.0	18.8	5.0	5.2	24.3	284.0	0.16
3	487.7	1.9	1.1	30.5	58.8	237.2	0.15
4	731.5	1.2	0.8	36.8	61.0	292.0	0.19
5	1188.7	1.2	0.6	55.2	75.7	325.7	0.23
9 - Fan	1371.6	1.1	0.7	60.0	85.5	328.7	0.24
10	1585.0	0.7	0.4	72.8	119.3	354.7	0.23
1	No dust recorded from shots						
6	No dust recorded from shots						
7	No dust recorded from shots						
8	No dust recorded from shots						

evidenced by the lower peak and average concentrations and the longer duration of the dust cloud. No dust was recorded at stations 1, 2, 3, 4, or 7, showing that the established ventilation was sufficient to keep the dust from migrating to the northern and southern areas of the mine.

Day two was designed to evaluate airflow patterns from distant face locations in the southern section of the mine. There were three shots that were approximately 1432 m from the main fan. All three faces were shot simultaneously in the same general area of the mine. The results from this test were notably different from day one results, but even from this distance, the fans did show a distinguishable airflow pattern.

As expected, station 2, located 122 m from the shots, showed the highest peak and average concentrations (18.8 and 5.0 mg/m³, respectively), but the duration of the dust cloud was long (278 minutes), indicating that the nearby booster fan was moving air to these headings but not effectively enough to remove the dust. The leading edge of the dust cloud then moved in sequence to stations 3, 4, and 5, located in the general air circuit, and then moved on to station 9 at the main fans. The peak and average values at station 2 were high in comparison to those at the remaining stations. Stations 3, 4, 5, and 9 all showed a similar pattern of long duration and low average and peak concentrations of the dust cloud. Even at these low values, the signature of the dust cloud was evident at all of the stations. These low values may indicate that a majority of the dust took a more direct path to the main fans; but since the arrival times at each successive station are in sequence, the data more likely suggest that the dust cloud was being diluting in the south-eastern area of the mine and gradually migrated to the main fans.

The calculated velocities at each station were consistent, increasing slightly as the dust cloud approached the fan. The velocity on the exhaust side of the fan (station 10) was also consistent. No dust was recorded at station 1, indicating that no dust was migrating back towards the intake portals. Also, no dust was recorded at stations 6, 7, or 8, showing that the dust was not migrating past the fans to the northern areas of the mine.

The study showed that the new ventilation system provided an improved directional airflow in the overall mine air circuit. Day one of sampling gave higher velocities than day two, showing a relation of airflow with proximity to the fans. The average velocity of the dust cloud from the two days of sampling was 0.25 m/s. The retention time or the length of time it took the dust cloud to clear the fans was estimated by using the 'end time' at station 9. This gave dust retention times on day one and day two of 1.2 hrs and 5.5 hrs, respectively.

Filtration and pressurisation systems for enclosed cabs

Many different types of mobile equipment used in surface mining utilise enclosed cabs to protect equipment operators. The overburden removal process is extremely dusty and can cause excessive exposure to respirable dust, especially crystalline silica. After equipment is used for years, many components of the enclosed cab deteriorate and the cab effectiveness at protecting the worker from dust is greatly reduced. In an effort to retrofit older enclosed cabs to provide acceptable air quality to the equipment operator, an effective retrofitted filtration and pressurisation system is essential.

NIOSH believes that there are two key components necessary for an enclosed cab to be effective from an air quality standpoint:

1. a well-designed filtration system, and
2. cab integrity.

A filtration system should be composed of both a recirculation and outside (makeup) air system. The majority of air inside an enclosed cab should be recirculated through a high quality filter

medium. This allows air to be conditioned (heating or air conditioning) to the cab operator's comfort without major air changes that significantly impact the size, capability requirements, and ultimately the cost for conditioning the cab air. Another consideration is to have separate fans for makeup and recirculating air.

A major component in an effective filtration system is to have the makeup air positively pressurise the enclosed cab. This results in any system leakage to travelling from the inside of the cab to outside, preventing dusty air from entering the cab. It is also highly recommended that the makeup air be positively pressurised after being filtered to eliminate any possibility of dust-laden air being drawn into the system. Additionally, the makeup air should optimally be located on the cab the furthest practical distance from the dust sources (Organiscak and Page, 2001). This reduces the amount of loading on the filters and increases the amount of time between cleaning or replacement. Finally, the discharge for makeup air into an enclosed cab should be located high in the enclosure, preferably at the roof. This allows the clean air to be blown down over the equipment operator's breathing zone without becoming contaminated by in-cab dust sources.

One last design criterion is a top-down approach to the clean air flow pattern. In most current systems, the intake and discharge for the recirculation air is located in the roof unit. Although this is acceptable, the most beneficial design is to blow in clean air from the roof and draw the recirculated air out from the bottom of the cab. This allows the dust-laden air to be drawn out of the cab near the worker's feet and away from the breathing zone. Discharging clean air low in the cab can entrain a significant amount of dust from soiled work clothes, boots, and a dirty floor (Cecala *et al*, 2001). Figure 7 represents an ideal schematic for an effective filtration and pressurisation system on a drill cab.

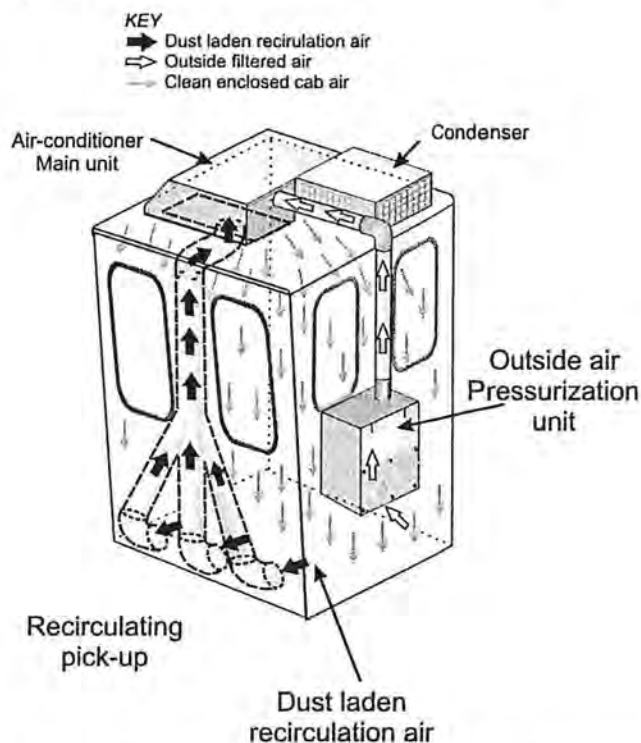

FIG 7 - Schematic for effective filtration and pressurisation system.

The second component for dust control effectiveness is cab integrity. Cab integrity is necessary in order to achieve some level of pressurisation. Field testing has shown that installing

new door gaskets and plugging and sealing cracks and holes in the shell of the cab have a major impact on increasing cab pressurisation. To prevent dust-laden air from infiltrating into the cab, the cab's static pressure must be higher than the wind's velocity pressure. Although higher static pressures help overcome outside wind speeds, a major drawback is that this necessitates more air being delivered by the outside air unit, causing more loading on the filters. Higher air flows through filters can also decrease the filter's efficiency by allowing more contaminants to flow through the filter media. Another drawback to higher airflows is that they create more air conditioning requirements (heating and cooling) for operator comfort, which increases the size and cost.

When a loss of cab pressure is determined, this indicates that there is either a filter loading problem or a cab integrity failure. Filter maintenance should be performed periodically when a predetermined pressure loss occurs over time. A sudden increase in pressure normally indicates a major failure in one of the filters and this problem needs to be immediately corrected.

It has been shown through numerous NIOSH field studies that effective air filtration and pressurisation systems can reduce the equipment operator's respirable dust exposure, as well as provide a working environment that is more controllable and comfortable. In one study, a drill operator's respirable dust exposure was reduced from 0.64 mg/m³ to a level of 0.05 mg/m³ with a new filtration and pressurisation system. This represents a 79 per cent reduction in respirable dust concentrations when outside dust measurements were normalised because pre-testing levels were significantly higher than post-testing. When considering the reduction in silica exposure, the drill operator had an average silica exposure of 57 µg/day for pre-testing, as compared to 3.5 µg/day for post-testing.

Air filtration and pressurisation systems can be very effective in removing the respirable size range of dust particles (less than 10 µm), which are harmful to a worker's lungs. The systems can also provide pressurisation to the enclosed cab many times without requiring any changes to the enclosure. The pressurisation of 50 to 100 Pa ensures that the wind does not blow dust from outside into the cab.

Clothes cleaning technique

A cooperative research effort between UNIMIN Corporation and NIOSH has resulted in an improved method for cleaning dust-soiled work clothing at mineral processing operations. This new clothes cleaning process was implemented in the milling facility at UNIMIN's Marston, North Carolina operation. From testing at this facility, it has been shown that this newly developed technique is a quick, safe, and effective method to clean dust-soiled work clothing.

Currently in the United States, the only approved method to perform clothes cleaning by the federal mining regulatory agency is to use a HEPA-filter vacuuming system. To perform this technique, a worker uses the vacuum hose and manually moves the nozzle over his/her soiled clothing in an attempt to remove the contamination. This is a very difficult and time-consuming task to perform. Because of this, few workers actually use this technique and prefer to use a single compressed air hose to blow dust from their work clothing, even though this is not an approved method of cleaning. Normally this is performed at high pressures and in the open work areas, which not only contaminates the worker, but co-workers as well. While investigating a new approach to perform this clothes cleaning process, it was critical to be able to meet the federal regulations and standards and come up with a process that workers would want to use.

The initial step of the clothes cleaning process design was to develop a safe area to clean clothing. An enclosed booth was purchased from a manufacturer and installed at the Marston

facility. This booth provided the worker sufficient space to effectively perform the cleaning operation. Above the door was an open grate that provided an intake for the ventilation airflow. A return air plenum located on the bottom-back wall of the booth was ducted to the baghouse dust collector system, which provided a constant flow of air through the enclosure. Since the booth is under constant negative pressure, it proved to be an effective area for clothes cleaning because it did not allow any dust leakage to the workplace.

The next critical step was to develop an effective method to remove the product from the clothing. To do this, air nozzles were installed in a spray manifold that used compressed air to blow the dust from the worker's clothes. A considerable amount of design effort went into determining the most effective spray nozzle manifold configuration, with numerous laboratory tests conducted at the NIOSH Pittsburgh Research Laboratory. Through this laboratory testing, researchers evaluated the impact of varying cleaning distances, clothing type, nozzle types, nozzle spacing, air pressure, and spraying duration to optimise the cleaning effect.

The final design was composed of an air spray manifold fabricated from 38 mm schedule 80 plastic PVC pipe that was capped at the base. The air spray manifold was actuated by the worker performing the cleaning process by operating a timer-set pneumatic valve located on the top of the manifold. The pneumatic valve had a safety interlock option which would automatically shut the air supply to the manifold if the exhaust ventilation system failed to keep the booth under sufficient negative pressure. Twenty-six flat-fan air nozzles were mounted along the manifold, spaced on 51 mm centres. The bottom nozzle was a circular design located 152 mm from the floor. This nozzle was used in coordination with a ball-type adjustable fitting that was directed downwards to clean the individual's work shoes or boots.

At a pressure of 208 kPa, the air spray manifold system expels 4.7 m³ of air for the typical cleaning period. In order to supply this compressed air volume to the air nozzles for effective cleaning, a 0.45 m³ air reservoir tank was necessary. This tank was installed at the operation and was typically pressurised to the 1.04 MPa level which holds approximately 5.1 m³ of air at this pressure. The air reservoir was located directly behind the cleaning booth and hard-piped to the air spray manifold located inside the booth. Supply air to the manifold was regulated down to 208 kPa. The air regulator was located in a lock-box enclosure to prohibit anyone from tampering with the air pressure. Figure 8 shows the cleaning booth, air reservoir, and air manifold configuration.

A matrix of tests was performed at the Marston facility to evaluate the effectiveness of this newly developed technique. For this field testing, the new clothes cleaning technique was compared to the vacuuming system and the single handheld compressed air nozzle. In addition, two different coverall types were tested, being 100 per cent cotton and a cotton-polyester blend. Prior to each test, the coveralls were soiled with limestone dust to a degree that represented an extreme case of soiling. Results of testing indicated that the manifold cleaned the clothes ten times faster and removed 50 per cent more dust than the single air nozzle or vacuuming methods.

Table 3 provides the cleaning times and the remaining dust weights on the coveralls from the three different techniques evaluated. These values represent averages calculated for two NIOSH test personnel for a total of 96 tests. Figure 9 shows the effectiveness of the cleaning techniques tested.

The worker performing the cleaning process is required to wear a half-mask fit-tested respirator with an N100 filter, hearing protection, and full-seal goggles. Respirable dust samples taken inside the respirator of the test personnel performing the clothes cleaning process showed minimal to no respirable dust exposure. In more than half of the 48 tests performed with the air spray

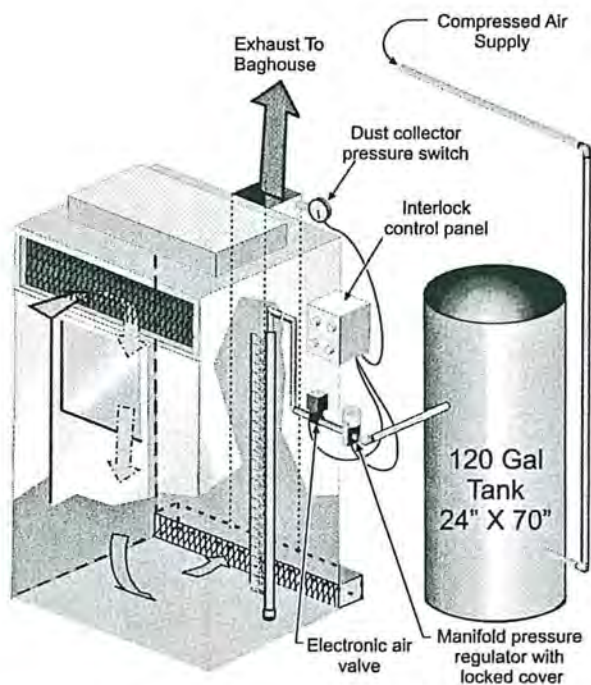

FIG 8 - Clothes cleaning technique design.

TABLE 3

Amount of dust remaining on coveralls after cleaning time for cotton and polyester/cotton blend coveralls.

Cleaning method	Cotton		Poly/Cotton blend	
	Dust on coveralls (grams)	Clean time (seconds)	Dust on coveralls (grams)	Clean time (seconds)
Vacuuming	63.1	398	45.5	346
Air hose	68.8	183	48.4	173
Manifold	42.3	17	21.9	18

manifold, the test subject's respirable dust concentration remained at 0.00 mg/m³ inside the half-mask respirator. In the remainder of the tests, the value remained very low with an overall average respirable dust concentration of 0.02 mg/m³.

Another factor evaluated during this study was the cleaning effectiveness of the process on two different coverall fabrics. Table 3 also indicates that there was a significant improvement with the cleaning effectiveness of the polyester/cotton blend coveralls when compared to the pure cotton type. This issue should also be considered by operations implementing this new clothes cleaning process.

The new clothes cleaning process proved to be very efficient since the worker only needed to don the required personal protective equipment (PPE), enter the booth, actuate the automatic valve, slowly spin in front of the air spray manifold (taking roughly 17 seconds), and exit the booth with clean clothing. This process has been demonstrated to be a much more effective method to remove dust from a worker's clothing than methods currently used by workers. The clothes cleaning process is not currently approved for use in the mining industry in the United States and companies wishing to use this technique must file a petition for modification to the Mine Safety and Health Administration. Although this process was designed for workers in the mining industry, it is applicable to any industry where contaminated work clothing is a problem.



FIG 9 - Effectiveness of three different clothes cleaning techniques.

CONCLUSION

The purpose of this report was to provide a number of different applications where ventilation improved the air quality in the surface and metal/non-metal mining industry. The technology discussed ranged from improving the ventilation design in a large iron ore processing facility to ventilating a small booth used to remove dust from a worker's clothing. In all cases, the ventilation component of this research provided a crucial component in improving the air quality and lowering respirable dust exposures to workers in the mining industry. One function of this manuscript was to broaden the view on ventilation by highlighting some recent technology that has proven to be effective in the NIOSH dust control research program.

REFERENCES

Cecala, A B, Klinowski, G W and Thimons, E D, 1993. Reducing respirable dust concentrations at mineral processing facilities using total mill ventilation system, BuMines RI 9469.

Cecala, A B, Organiscak, J A and Heitbrink, W A, 2001. Dust underfoot - enclosed cab floor heaters can significantly increase operator's respirable dust exposure, *Rock Products*, 104(4):39-44.

Chekan, G J, Colinet, J F and Grau, R H, 2004. Evaluating ventilating air movement in underground limestone mines by monitoring respirable dust generated from production shots, in *Proceedings Tenth US Mine Ventilation Symposium*, Anchorage, Alaska, 17 - 19 May.

Industrial Ventilation - A Manual of Recommended Practice, 2001. 24th edition (American Conference of Governmental Industrial Hygienists: Cincinnati).

Organiscak, J A and Page, S J, 2001. Improved cab air inlet location reduces dust levels and air filter loading rates, *NIOSH Technology News*, 485.