

Proceedings
of the
8th US Mine Ventilation Symposium

June 11-17, 1999
Rolla, Missouri

Jerry C. Tien
Symposium Chairman and Proceedings Editor

**Department of Mining Engineering
School of Mines and Metallurgy
University of Missouri-Rolla**

Sponsored by

Underground Ventilation Committee of SME
Joint Committee of the Coal Division
and Mining & Exploration Division
and
The University of Missouri-Rolla

Published by
University of Missouri-Rolla Press
Rolla, Missouri ♦ 1999

Comparison Of Methane Concentrations At A Simulated Coal Mine Face During Bolting

Charles D. Taylor
NIOSH
Pittsburgh, PA 15236
U.S.A

Edward D. Thimons
NIOSH
Pittsburgh, PA 15236
U.S.A.

Jeanne A. Zimmer
NIOSH
Pittsburgh, PA 15236
U.S.A.

ABSTRACT

Strategies for monitoring methane levels during roof bolting in an extended cut entry were evaluated. Testing was conducted at the Pittsburgh Research Laboratory's methane test gallery. Operating conditions were varied and methane releases at the face and drill holes were simulated. Methane readings were taken at the face, and at locations outby the face. Results show that, when the major source of methane was at the drill holes, the highest methane readings were at locations on or 6.1 m (20 ft) inby the bolting machine. Methods for selecting better outby sampling locations, when the majority of the methane is released at the face, are examined. During roof bolting it is easier to sample at these outby locations rather than at the face. Further testing is needed to determine what relationship exists between methane concentrations at the outby locations and at the source of the methane release.

KEYWORDS: Roof bolting, Methane monitoring, Ignitions

INTRODUCTION

Almost half of all continuous coal mine sections today have approvals for making extended cuts. Any cut, with a continuous mining machine, that extends more than 6.1 m beyond permanently installed roof support (usually the last row of roof bolts) is considered an "extended cut." Research at the Pittsburgh Research Laboratory (PRL) includes the development and testing of sampling strategies for monitoring methane levels during extended cutting.

Frictional ignitions can occur during mining and bolting operations. During mining, a flammable mixture of methane, primarily released from the face, is ignited when it comes in contact with hot metal deposited on the rock by the cutting bits.

A review of MSHA roof bolter face ignition reports, for the period 1981 through 1994, shows that almost all the ignitions during bolting originated at the collar of the drill hole. In most cases, methane was ignited by a hot drill bit that had been cutting hard or abrasive rock. Usually the flame started at the hole and traveled only a short distance. The source of the methane during these bolting incidents is believed to be roof gas feeders at or near the drill hole.

Methane is liberated at the face at a lower rate than during mining, but the gas can accumulate at the face if

insufficient face ventilation is provided. For some of the bolter ignitions, methane at the face could have contributed to the spread of the flame from the drill hole.

Drilling usually occurs away from the face. During bolting of an extended cut entry the face could be 11 m (36 ft) or more from the roof bolter. The primary way to assure that methane concentrations are not ignitable is to monitor methane levels near the drill hole. Measurements must also be taken during bolting to determine methane concentrations at the face.

Federal regulations require monitoring of methane levels at the mining face during mining and roof bolting to assure that gas concentrations do not exceed one percent. Monitoring must be conducted:

"At 20-minute intervals, or more often if required in the approved ventilation plan at specific locations, during the operation of equipment in the working place." (CFR 75.362 (d) (1) (iii))

The readings are to be taken at least 0.3 m (1 ft) from the face or roof. In most cases the readings are accomplished by holding a methanometer approximately 0.3 m from the face.

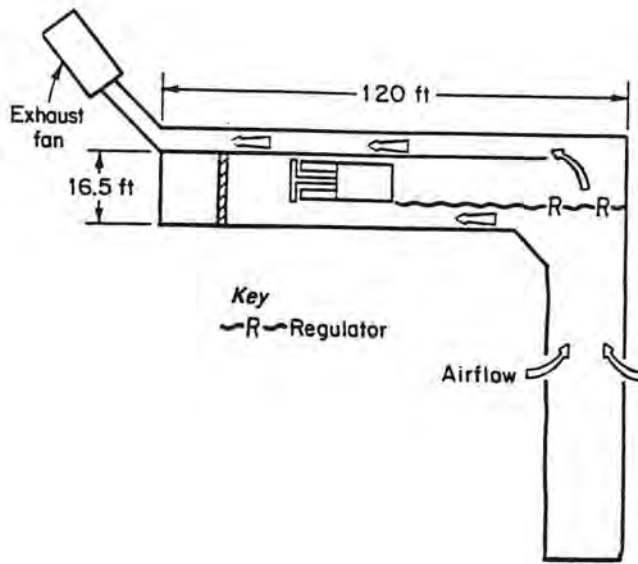

Figure 1. Methane test gallery.

If the distance to the end of the cut is more than 6.1 m, it is more difficult to comply with the monitoring requirements because the readings must be taken from under permanently supported roof. If the entry is not bolted up to the face, "...extendable probes or other acceptable means..." (CFR 75.362 (d) (2)) must be used to position the methanometer at the face.

Several different techniques have been tried to measure methane at the face during bolting of a deep cut. None of the techniques currently available for making methane measurements during bolting are easy to use, or have been widely accepted. Compliance with the methane standard would be easier if there were alternative sampling locations outby the face. Outby sampling locations closer to the bolting operation could also provide better measurements of methane when the primary liberation point is the drill hole.

During a series of tests at the PRL, an extended cut roof bolting operation was simulated in the surface test facility. Methane concentrations were measured at three locations 0.3 m from the face, and eight locations farther outby the face. Methane concentrations were measured at the face and outby locations for different gas release locations and operating conditions. Comparisons of concentrations at the sampling locations were made using scatter diagrams and linear models.

Test Facility and Roof Bolter

Testing was conducted in PRL's Methane Test Gallery. One side of the "L" shaped building (see figure 1) is designed to model an underground mining face entry which has dimensions, 5 m (16.5 ft) wide by 2.1 m (7 ft) high by

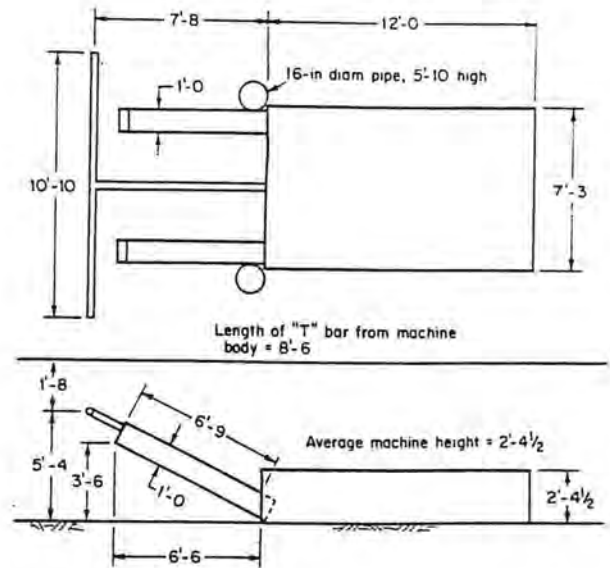

Figure 2. Model roof bolting machine.

37 m (120 ft) long. The return air from the face exits the entry behind a brattice and wood wall located on the right side of the entry.

A full-scale model of a roof bolter (figure 2) was used during these tests. The width of the model bolter was made slightly narrower than a normal bolter to conform in proportion to the 5 m width of the entry. The model had two drill booms, which were kept in a fully raised position, and an ATRS system (T-bar).

Methane Sampling Locations

Catalytic heat of combustion methanometers were used to monitor methane levels at each of 11 sampling locations. The locations were divided into three areas designated, "face," "sweep" and "machine." The sampling locations are described below and show in figure 3.

Face Area (Locations 1, 2 and 3)

- 1 0.3 m from roof and manifold and 0.6 m (2 ft) from right wall
- 2 0.3 m from roof and manifold at center of entry
- 3 0.3 m from roof and manifold and 0.6 m from left wall

The face instruments remained at the same location for all tests. Methanometers are usually positioned at one of these locations to meet current methane sampling requirements. Concentrations at the three locations were averaged to determine the "average face concentration."

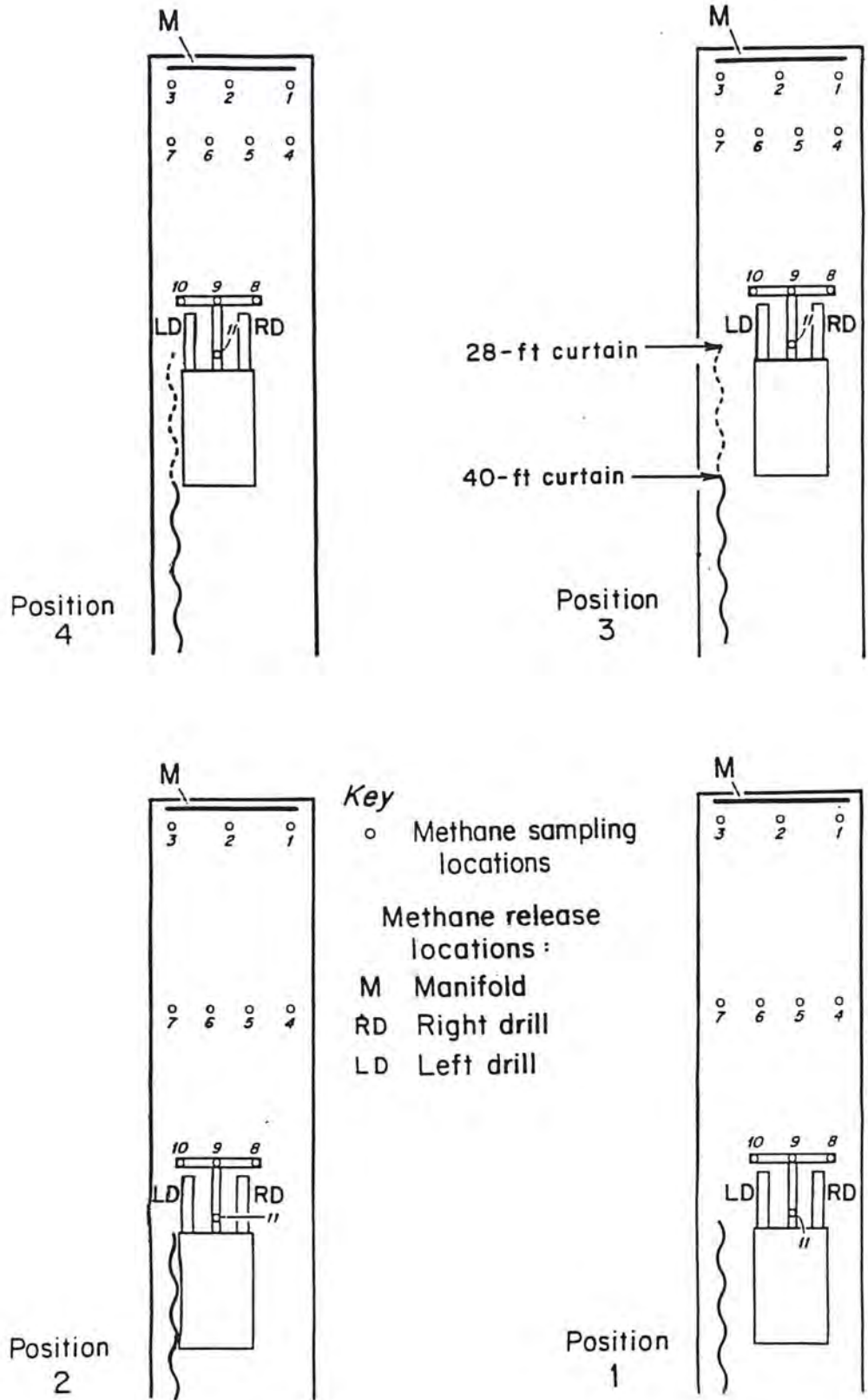

Figure 3. Bolter positions and methane release and sampling locations.

Sweep Area (Locations 4, 5, 6 and 7)

- 4 0.3 m from roof, 0.6 m from right wall,
- 5 0.3 m from roof, 1.8 m (6 ft) from right wall,
- 6 0.3 m from roof, 3 m (10 ft) from right wall, and
- 7 0.3 m from roof, 4.3 m (14 ft) from right wall

The sweep locations were always 6.1 m in by the "last row of bolts." The distance from the face varied with machine position. A person standing under the last row of bolts could use a 6.1 m pole to hold a methanometer at any of the sampling locations in the sweep area.

Machine Area (Locations 8, 9, 10 and 11)

- 8 Right end of ATRS "T-Bar," 0.3 m from roof
- 9 Middle of ATRS "T-Bar," 0.3 m from roof
- 10 Left end of ATRS "T-Bar," 0.3 m from roof
- 11 0.3 m from roof, at the last row of bolts and above the centerline of the bolter

The sampling locations did not change on the machine but did move when the bolter changed position.

Methane Release Locations

During continuous mining of coal, most methane in the face area comes from either the newly exposed face, or pieces of broken coal as they are crushed by the rotating miner head. During roof bolting it is more difficult to determine the major methane emission sources. An analysis of MSHA roof bolter reports, mentioned earlier, indicates that most of the methane comes from roof feeders near the drill holes.

Separate tests were conducted to simulate release of methane from either the face or roof bolt drill holes. Release locations are shown on figure 3. To model uniform face emissions, methane was released through four 3.7 m long horizontal pipes positioned at the center of the face. Holes, 2 mm (1/16 in) in diameter, were drilled 5 cm (2 in) apart on top and bottom of each pipe. Emissions from the drill hole were simulated by placing the end of the gas supply hose against the roof, adjacent to either the right or left drill booms. The end of the hose was covered with a perforated plastic bag. The gas release rate for all tests was for all tests was 2.4 l/sec (5 cfm).

Operating Conditions

Machine positions, intake flow and curtain setback distance were varied to simulate different conditions that could be encountered during roof bolting. There were 12 different operating conditions, and each test condition was repeated once. The results of the replicated tests were averaged. The variables for each test are given in Table 1 and described in more detail below. Tests with the 12 operating conditions were repeated for each of the methane release locations.

Machine Position

Tests were conducted with the roof bolter at four different positions (figure 3). The machine was positioned so the bolter controls, adjacent to the drill booms, would be under the last row of bolts. For these tests it was assumed the last row of bolts was either 8.5 or 12 m (28 or 40 ft) from the face. Therefore the operators' controls were 8.5 m from the face when at positions 3 and 4 and 12 m from the face when at positions 1 and 2. Moving from positions 1 and 2 to positions 3 and 4 would have required an underground bolter to have installed three rows of bolts (4 ft centers).

Intake Air Flow and Curtain Position

Total airflow entering the test gallery was approximately 397 m³/min (14,000 cfm). Blowing brattice was used to direct intake airflow toward the face. The brattice was attached to a wood frame that was constructed 0.6 m from the left side of the entry. Regulator doors (figure 1) were opened or closed to provide intake curtain flows of either 113 or 198 m³/min (4,000 or 7,000 cfm). Intake flow was measured using an anemometer traverse at the inby end of the brattice.

Curtain setback distance was 12 m for all tests with the bolter at positions 1 or 2. At bolter positions 3 and 4 tests were conducted with 8.5 and 12 m setback distances. The latter distance represented advancement of the curtain to the last row of bolts.

Data Collection

Prior to the start of each test the desired operating conditions (curtain setback, intake flow and machine position) were set up. Next, the valve to release gas from one of three locations (face, right drill, left drill) was opened. After allowing 5 minutes for gas and air to mix in the gallery, data was collected for the next 5 minutes. For the entire 10 minute test period, data from each methanometer was down-loaded every 2 seconds to a personal computer via an A/D conversion board. A computer spreadsheet was used to calculate the average methane concentration for each sampling location.

RESULTS

The graph on figure 4 compares the effects of the methane release location with methane concentrations measured for the three sampling areas. Concentrations from all tests for a given sampling area were averaged for each release location. The concentrations were highest at the face when gas was released from the manifold, and highest at

Table 1.—Test operating conditions

Test Condition	Distance Curtain from Face (m) ft	Intake Flow Quantity	Machine: Right or left side of entry	Machine Distance From Face
1	40	7000	Right	40
2	40	7000	Right	28
3	40	7000	Left	40
4	40	7000	Left	28
5	28	7000	Right	28
6	28	7000	Left	28
7	40	4000	Right	40
8	40	4000	Right	28
9	40	4000	Left	40
10	40	4000	Left	28
11	28	4000	Right	28
12	28	4000	Left	28

the sweep and machine locations when gas was released from the right or left drill locations.

For the manifold release tests, concentrations measured at the face were compared to concentrations measured at the sweep and machine locations. Scatter diagrams (figure 5), drawn for each of the outby locations, include data for all 12 test conditions. The "best straight line" was drawn through each of the scatter diagrams using the method of least squares. Estimators of each line's slope (b_1) and y intercept (b_0) are given in Table 2.

The student t distribution was used to determine, for each straight line, if there is a statistically significant difference (95% confidence) between the slope of the line and zero. If the slope is not significantly different from zero it can be concluded that there is no linear relationship between the variables (Table 2). "P values" are also given in Table 2 for each straight line. A "P-Value" less than 0.05 indicates there is a statistically significant (95% confidence or greater) relationship between the concentrations at the face and outby locations.

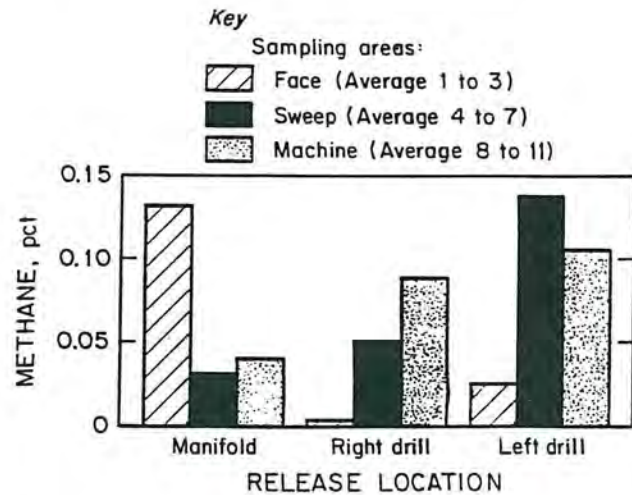

Figure 4. Effects of release location on concentration.

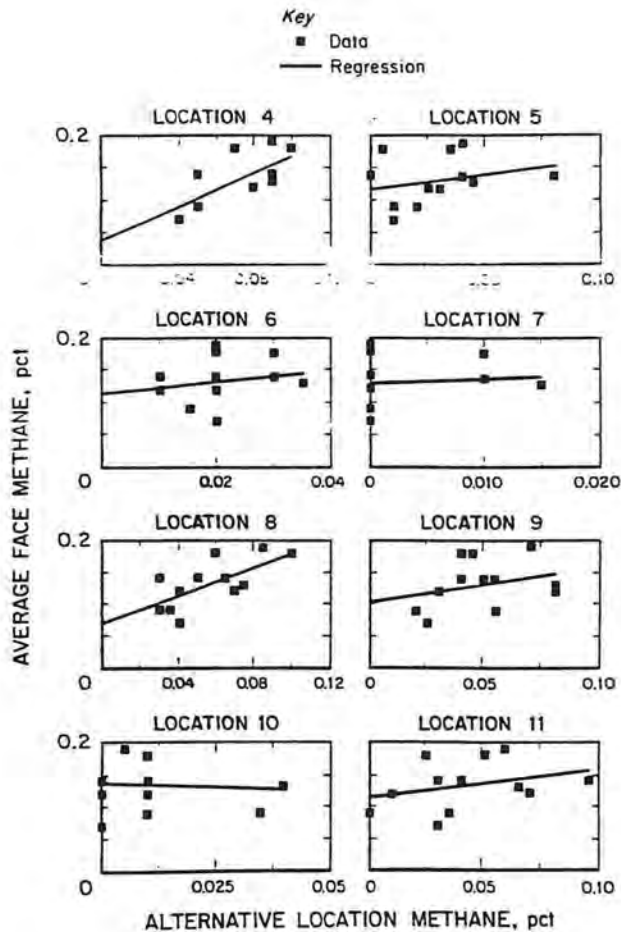

Figure 5. Comparison of methane concentrations at face and outby locations.

DISCUSSION AND CONCLUSIONS

Changing the methane release location had a large effect on concentrations measured in each of the sampling areas. The effects of release location on concentration can be partly explained by noting the distance between the source and sampling location. The closer the source, the higher the concentration. Airflow patterns also had an effect on concentration.

With the aid of smoke tubes, airflow diagrams were drawn for each condition tested. Figure 6 illustrates a typical airflow diagram from the roof bolter tests. In general, intake air moved up the left side of the entry, across the face, and back the right side of the entry to the return. Eddy currents formed between the right and left side flows. All of the methane released from the manifold passed through the sweep and machine sampling areas. Only part of the methane released from either drill release location reached the face.

Based on the distance from the methane source and airflow patterns during roof bolting, it would be expected during roof bolting that:

- Gas concentrations will be higher in the sweep and machine areas when the major source of the methane is from the drill hole.
- Gas concentrations will be higher at the face when the major methane source is from the face.

These expectations were confirmed by the sampling data (figure 4).

Concentrations at the face were compared to concentrations measured outby the face, for tests having manifold gas releases. The average of the three face readings was used to represent the single reading that would be taken at the face to determine compliance with the current methane standard. Scatter diagrams were drawn to show the relationship between the average face concentration and concentrations at the eight outby locations.

Linear regression techniques were used to draw the "best straight line" through each set of data. A linear model was used because it is the simplest model, and there is no reason to believe any other model would fit the data better.

The student t distribution was used to determine if there was a significant relationship between concentrations at the outby locations and the average concentration at the face. The "t-test" results showed that, at the 95% confidence level, there were significant relationships between concentrations at locations 4 and 8 and the face. For the other outby sampling locations there were no significant relationships to face concentration.

The airflow pattern (figure 6) shows that airflow from the face passes over locations 4 and 8. It would be expected, therefore, that there would be some relationship between gas levels at the face and the outby sampling locations.

A test of significance does not prove that an outby sampling location should, or should not be used as an alternative sampling location for face sampling. The results do indicate that, using straight lines as models, there is a statistically significant relationship between the average face concentration and the concentrations measured only at locations 4 and 8.

The scatter diagrams show how much the data points were spread around each of the straight lines. Values for R^2 , a measure of the clustering of points about a regression line, are given in Table 2. Although the scatter of data around the lines for locations 4 and 8 is

Table 2.—Results for "best straight lines"

Avg. Face conc. Vs	Y-Intercept (b_0)	Slope (b_1)	t-test 95% Confidence (Significance)	R ² (Percent)	P-Value
Loc. 4	.04	1.29	yes	48.7	.01
Loc. 5	.12	.52	no	9.2	.34
Loc. 6	.12	.72	no	2.5	.62
Loc. 7	.13	1.17	no	4.2	.52
Loc. 8	.07	1.11	yes	48.1	.01
Loc. 9	.10	.60	no	9.8	.32
Loc. 10	.14	-.35	no	1.6	.69
Loc. 11	.11	.45	no	10.6	.30

less than for the other sampling locations, the R² values are still relatively low. When using data measured at the outby locations to predict face concentrations, the variation about the regression lines must be taken into account. Part of the variation was due to changes in the operating conditions (curtain setback, curtain flow, and machine position). Further studies are needed to determine the relative importance of these and other factors.

The action level for methane at the mining face is 1.0 percent. Concentrations measured during these tests were less than 0.2 % methane. Future testing will be conducted with higher methane flow rates to determine if the same relationships obtained from the current study are true for face and outby sampling locations. With data concentrations near the action level, confidence limits can be determined for the straight line models.

The results show that methane concentrations were higher at the machine and sweep locations when methane was released at the drill hole. Using sampling locations closer to the drilling operation (e.g., sweep and machine locations) could provide better predictions of methane concentrations at the drill holes. Additional testing is needed to determine what relationship exists between concentrations at the sweep and machine locations and locations adjacent to the drill hole. Methane sampling locations should not be changed unless it can be demonstrated that the change provides the same or greater level of safety for the worker.

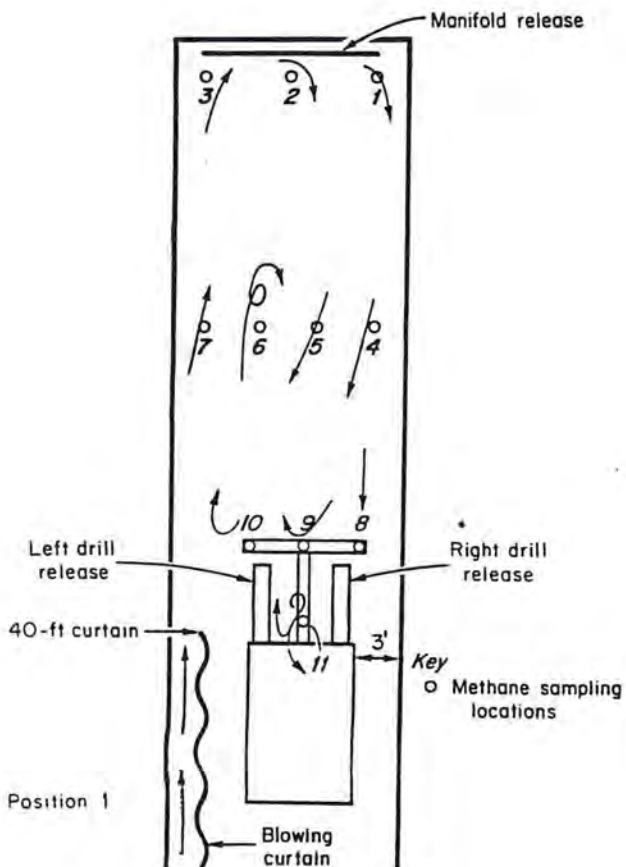

Figure 6. Face airflow patterns