

**DESIGN PARAMETERS OF ROOF SUPPORT SYSTEMS
FOR PRE-DRIVEN LONGWALL RECOVERY ROOMS**

S. C. Tadolini
T. M. Barczak
NIOSH
Pittsburgh, PA

ABSTRACT

Reduction in the recovery time required and improvements in safety during a longwall face move have compelled coal mine operators to examine and use pre-driven longwall recovery rooms. The recovery entry is developed at the longwall stop position and supported ahead of time so that the required combinations of standing and internal supports can be installed before the longwall face approaches. A calibrated three-dimensional finite element model, developed in conjunction with an underground test area, provided the critical components and design principals for a comprehensive parametric study. The study indicates that vertical, horizontal, and shear stresses concentrated on the outby abutment pillar corner of the recovery room resulting in deformations in the immediate roof above the primary roof support anchorage level. The results of the numerical model and field site observations indicated that the combination of the internal bolting system and the standing concrete supports are critical for the successful and safe extraction of the longwall equipment. Cable supports installed at an angle over the pillars can help stabilize the disturbed zone above the adjacent fender and outby pillars, however; standing supports are required in most sedimentary roof conditions to increase stability and assure a safe longwall extraction.

INTRODUCTION

Moving longwall equipment from the end of the current panel into the next start or set-up room has always been an operation that requires thorough engineering and planning. Conventional methods require that a pre-determined location be established and preparations be made between 12 to 14 shearer cuts from the extraction point. After each cut is taken, welded wire mesh or chain link material is placed above the shield canopy so that the mesh overlies the shields to be extracted at the longwall stop position. The selected material is usually reinforced with steel wire ropes that run the width of the longwall panel. The last 8 to 10 ft are mined and the shields are not advanced. This area is prepared for shield extraction by installing wire mesh or chain-link material against the mine roof and pinned with bolts. In most cases, either hand-held drilling equipment or specialized single boom bolters designed for this application are used. The meshing and bolting cycle times can vary from operation to operation and are usually a function of the immediate roof condition. Experience in the longwall recovery areas of this particular field site has shown that the weak roof must be heavily reinforced with wire mesh and long bolts to control the area during the tear-down and extraction process.

Recent improvements to the longwall extraction process have been made with the introduction of nylon woven geotextile materials. The material is usually provided in one pre-assembled sheet that permits coverage of the entire longwall roof area. Briefly, the fabric is brought into the mine in a roll and is transported down the longwall face on top of the conveyor pan. The material is hung up on the shield tips and is unrolled so it will unwind behind the shields as the face continues to advance, usually 25 to 40 ft. At the longwall stop position the material is bolted to the roof using the same equipment and techniques utilized in a traditional extraction. While these preparations are necessary to minimize the hazards of roof falls and prevent failed material from falling into the position of the extracted shield, they can also slow the advance rates, impede production, and, more importantly, do not eliminate the hazards associated with applying the wire-mesh or geotextile materials during the shield recovery process. When the face withdrawal begins, additional reinforcements or support such as roof bolts, cribbing, I-beams, props, and even polyurethane injection may be required to stabilize the entry for safe shield removal. The area restricted, which often makes the movement and installation of these materials cumbersome and potentially hazardous.

As an alternative to this described method, mines have investigated and utilized pre-driven recovery rooms for longwall face moves. This entry is developed and supported ahead of time so that the required combination of standing and internal support and reinforcement can be installed before the longwall face approaches. The major benefit of this approach is that the supports are placed under traditional development mining conditions, installed with an automated temporary roof support (ATRS) roof bolting system. The ATRS limits the exposure of the operators to the hazards associated with roof bolts installed with hand-held equipment and narrow profile line bolters under unsupported and highly stressed roof. Pre-supported recovery rooms would also permit all of the required supports and reinforcement to be installed prior to the front abutment pressures, which can create production problems and support delays using traditional longwall equipment recovery methods.

To investigate the feasibility of a pre-driven longwall recovery room, a pre-driven room was mined and supported between two existing recovery chutes as shown in Figure 1. The recovery room, driven 170 ft long and 16 ft wide, was supported with several types of internal roof reinforcements and high-capacity roof-to-floor cuttable concrete cribs. Instrumentation was installed to monitor the loading and stiffness characteristics of the cribs and differential sag-stations were used to help evaluate the roof behavior. Additionally, understanding the actual field re-

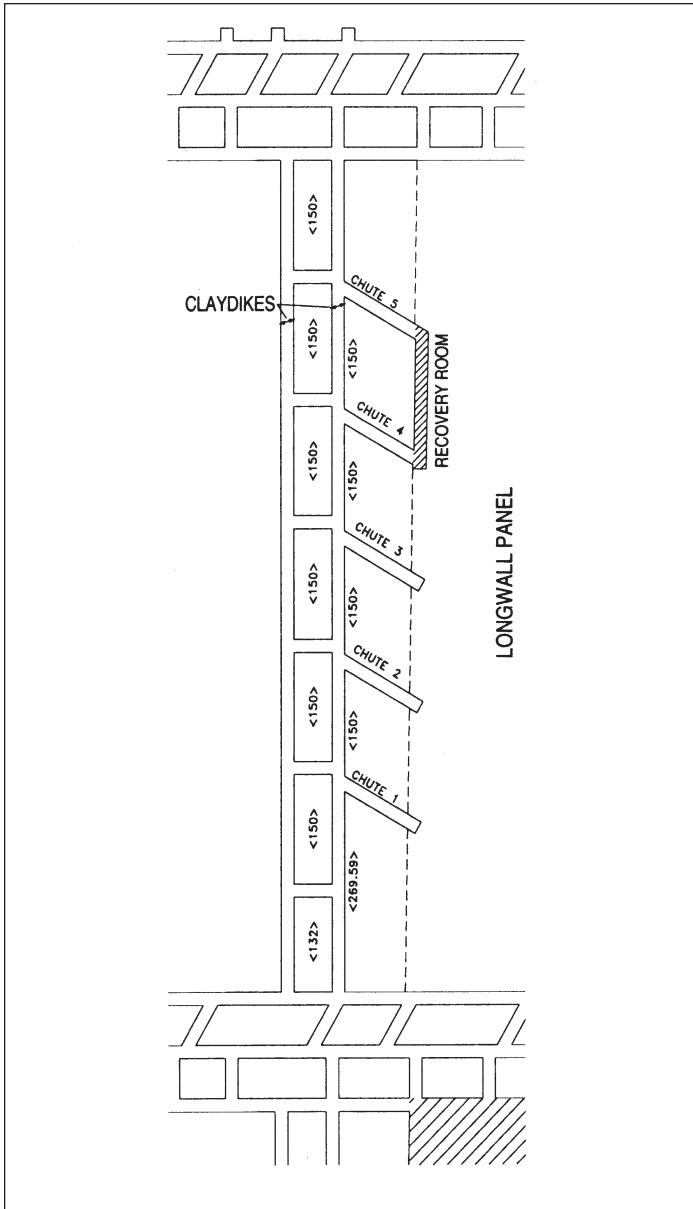

Figure 1. Plan view of longwall recovery area. Recovery room between chutes no. 4 and no. 5.

recovery entry were mined 16 ft wide. The overburden depth was 312 ft and coal seam was 7.5 ft thick. The pillar centers in the area are shown to be 150 ft long and 65 ft wide. The recovery chutes were driven 120 ft into the longwall block on approximately 150 ft centers. The immediate roof consists of laminated shale that is 6 ft thick, overlain by gray shale of various thicknesses. A weak layer of claystone in the immediate floor ranged from 1 to 1.5 ft thick with an underlying competent limestone 5 ft thick. In general, this roof is considered extremely weak with calculated Coal Mine Roof Rating (CMRR) values that range from 40 to 45 (Molinda and Mark, 1994). Another consideration, and one of the reasons this area and method were selected, was the presence of a series of clay dikes that intersect the coal seam and interrupted the roof and floor members. These features are not new to this operation and the areas adjacent to the dikes were generally found to be extremely weak and unconsolidated. Operations felt that the safest way to extract the longwall equipment from this area, limiting personnel exposure to the hazards, would be to use a pre-driven recovery room. The clay dike zones would be supported with additional bolts and surface control measures prior to the forward abutment stresses created by the approaching longwall.

FINITE ELEMENT RESULTS

The finite element models for longwall mining encompass a large area because they must include the adjacent gob zones from the previously mined panels, the entry and pillar systems, and the moving longwall face. The only viable solution to obtain realistic results was to use 3-dimensional simulation. Due to the large size of the area of interest, the finite element modeling must be portioned into two steps, the global model and the sub-models. The global model is used to investigate the overall rock behavior around the longwall panel while the sub-model focuses on a particular section to allow detailed analyses. ABAQUS, used for this study, uses a sub-model linked with the global model by computed displacements to reduce the model size for the local response analysis. A cross-section of the sub-model is shown in Figure 2. To conduct this investigation the modeling consisted of three steps:

1. A global model was used to determine the magnitude and changes in the abutment pressures as the longwall face advanced toward the proposed recovery room. The goal was to determine the worst conditions the recovery room would be subjected to during the extraction.
2. A sub-model is extracted for the panel at the center of the global model. Two rows of concrete cribs, one at the center and the other against the inby rib of the proposed recovery room are installed.

sponse of the room and supports was supplemented with 3-dimensional finite element models. This paper describes the design process, support methodology, monitoring, and numerical results and presents specific suggestions and recommendations based on this research work.

RECOVERY ROOM TEST SITE AND GEOLOGY

The 1,000-ft-wide longwall face is located in the Herrin No. 6 coal seam in Illinois. A pre-driven recovery room was driven between the inby ends of the no. 4 and no. 5 recovery chutes, as shown in Figure 1. The five recovery chutes were developed months prior to the mining, reinforcement, and support of the recovery room. The recovery chutes are traditionally used as multiple access ways to remove face equipment during the longwall extraction. The longwall chutes and the

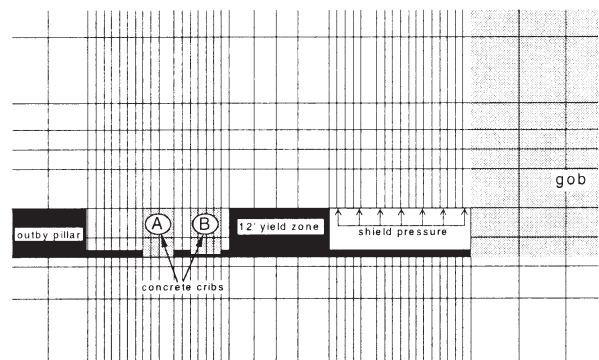

Figure 2. Cross-section of the 3-dimensional sub-model.

- The sub-model is used to simulate the cement crib loading, stress distribution around the recovery room, and the yielding of both the immediate roof and floor under the loading conditions to which the recovery room may be subjected.

Based on the finite element modeling results and engineering analyses, a complete reinforcement and support system design for the proposed recovery room was recommended.

The Global and Sub-model

The dimensions of the global model were 1,080 ft wide by 630 ft long and 350 ft high consisting of one-half the region from the previously mined panel and one half the region from the unmined panel. The global model consists of more than 105,000 elements run at 1/6 step per increment, requiring up to 20 hours of computer run time. The abutment pressures generated as a result of longwall mining were simulated using a special gob model (Morsy and Peng, 2001). All of the materials, coal, roof, and floor, were assumed to behave linearly-elastic until they reached yield as defined by the Mohr Coulomb failure criteria. Beyond the yield point the materials were considered to behave perfectly plastic.

The changes on the abutment pressures were investigated for three longwall face locations, that is, when the face was 60, 18, and 12 ft from the recovery room. The global model revealed that when the face was 12 ft from the inby rib of the recovery room, the 12 ft coal pillar fender yielded completely. This was defined as the worst possible scenario for the internal and external reinforcement and support systems. The peak abutment pressures of 1,200 to 1,500 psi were 3.5 to 4.4 times the estimated original vertical stress as a function of overburden (1.1 psi/ft x 312 ft). As expected, the abutment pressures at the center of the longwall face were larger than those calculated at both ends of the panel.

A three-dimensional sub-model, 168 ft long by 9 ft thick and 350 ft high, was extracted from the global model to represent the recovery room. As shown in Figure 2, two rows of 4-ft diameter concrete cribs were installed and a uniformly distributed load of 166 psi was applied to roof to simulate the powered shield support. A crib capacity of 900 tons was simulated to determine the abutment pressures applied as the longwall approached. The portion of the abutment pressures transferred to crib A, located close to the oncoming face, was 480 psi and 500 psi for crib B, which was located in the center of the recovery entry. The calculated maximum roof deflections above and adjacent to the cribs were approximately 2.8 inches.

REINFORCEMENT AND SUPPORT SYSTEM DESIGN

The result of the 3-dimensional finite element results provided the necessary criteria for consideration for the final reinforcement and support system design for the proposed recovery room. The main considerations were:

- The immediate roof above the recovery room, consisting of a 6-ft thick laminated shale, yields during the initial development of the recovery room.
- When the longwall face is 12 ft from entering the recovery room, the 12-ft coal block or fender pillar had yielded.
- The immediate roof continues to yield to a depth of 15 ft and the outby barrier pillar yields to a depth of 4 ft upon the arrival of the large forward abutment pressures.

- The immediate floor is claystone that yields on the outby side of the recovery room, but not under the concrete cribs.
- The roof in the outby portion of the recovery room away from the cribs, over the abutment pillars, could yield and fail as the longwall panel approaches.

Roof and Rib Bolting

Based on the five major points obtained from the modeling, combined with strata engineering experience, a roof and rib bolting plan was designed and implemented as shown in Figure 3. Two-piece, 9 ft long, highly tensioned resin-assisted bolts were specified to confine and maintain the weight of the laminated shale in the entire recovery room. The capacity of the bolts, 46,200 lbs or 23.1 tons, was nearly double the required design load of 12 tons. The majority of the bolts were installed with a 12-inch-square, 1/2-inch-thick plywood board and 8-inch-square bearing plates. To enhance the support capacity and provide the required suspension component, should a separation occur above the primary bolting system, three, 0.6-inch-diameter, 15-ft-long cable bolts with a 30 ton capacity, were installed through a roof channel as secondary reinforcement between the rows of primary bolts. The primary bolts and secondary cables were installed on a 4-ft row spacing. To help establish and maintain surface control, the entire roof was screened with 8-gage welded wire mesh. This operation's experience with prior longwall removals in the weak laminated shale roof dictated that full screening and a dense roof bolt pattern be utilized to control the immediate roof.

Additionally, two cables were installed as close as possible to the inby and outby side ribs of the recovery room. The outby side rib cable bolts were inclined at 30 degree angles from vertical to support the weak laminated shale roof adjacent and above the outby pillar. The model indicated that the roof in this zone could yield and fail as the longwall panel approached the area. The inby side cable bolts, angled at approximately 60-degrees from vertical, over the inby side rib of the shields to be recovered were installed to prevent shear failure in front of the longwall shields due to the yielding in this zone. These cable bolts would also help prevent the falls that have traditionally occurred immediately behind the longwall shields as they were removed.

The outby pillar rib was reinforced from the roof to the floor with welded wire mesh that was bolted with a full-column, resin-grouted, 4-ft-long, 1/2-inch rebar bolts. The bolts were placed in conjunction with 12-inch-square, 1/2-inch-thick, plywood boards and 8-inch-square bearing plates. The bolts were placed on about 5-ft staggered row spacing at the top and bottom of the mesh panels. The inby panel rib of the recovery

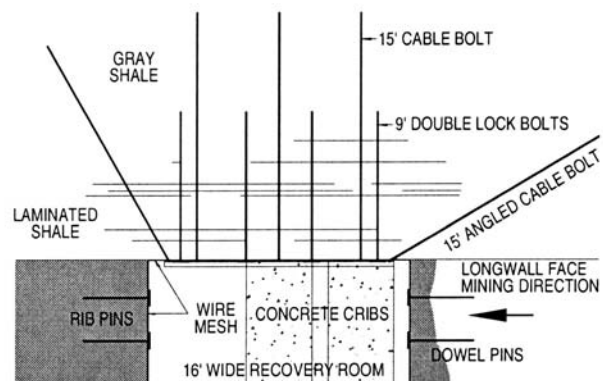

Figure 3. Roof and rib reinforcement system application.

room was reinforced with 1-inch-diameter wooden dowels anchored with resin. The dowels were 4-ft-long, and 12-inch square plywood boards served as the bearing plates. Wooden dowels were used for this application so they could be easily cut by the shearer and transported on the coal conveyor system.

For comparison and evaluation purposes, the calculated roof reinforcement of all of the installed reinforcement systems, the roof and cable bolts, was determined using the method described by Oylar *et al.*, 1998. This quantitative rating is calculated by determining the load capacity of each support per unit area of coverage, multiplied by the length of the system. The Reinforcement Density Index (RDI) has the units of psi ft. Because two-types of support were used, the supports were summed. The calculated RDI for the recovery room was 487 psi ft. Upon review of previous recovery room data, no roof fall failures (29 cases) were reported when the RDI was greater than 218 psi ft (Oylar *et al.*, 1998). The index calculated for this case does not take into account the additional surface and rib control achieved by using welded wire mesh, roof channels, rib bolts, and wooden dowels.

Standing Support

The standing support selected for the project was a 48-inch diameter Minova¹ cuttable crib. To ease the construction process and minimize interference to coal production, the crib and bag materials were supplied in traditional concrete trucks and pumped to the site through a 3.5-inch diameter pipe. The steel pipe was dropped down the 5.5-inch casing that was placed in the original 8-inch diameter borehole, allowing enough room for a communications line that was critical to the pouring process. The cribs were poured in two lifts into a 5-mil thick plastic bag supported by reusable fiberglass forms. Two rows of staggered cribs were placed on 10-ft crib spacings. The first row was placed about 1-ft from the inby side rib of the recovery room while the second row was placed in the center of the entry. To provide some additional yielding capability, roof contact was established by filling 4-ft square woven nylon bags or pillows filled with a pliable cementitious grout. The pliable grout was supplied from the surface down the 3.5-inch diameter pipe and the bags filled until they were in contact with the mine roof. The final height of the cribs ranged between 81 and 88 inches while the bag thickness varied between 8 and 14 inches. The engineering specifications for the concrete materials were 3,500 psi for the crib and 800 psi for the bags. Based on the strength of the 34 cribs with a diameter of 48 inches and the dimensions of the recovery room (16 ft wide and 170 ft long), the total standing support capacity being used to minimize the mechanisms of a weighting failure distributed across the room was calculated to be 550 psi. The plan view of the crib locations and internal roof support system are shown in Figure 4.

Instrumentation

An instrumentation package was selected that would help evaluate the performance of the cribs and the primary and secondary roof support systems. Ten differential sag-stations were installed across the room and in the recovery chutes to monitor roof deformation. The differential sag-station anchors were located at the 6-, 10-, and 15.5-ft depths into the mine roof. Roof-to-floor closure stations were established at the same locations so that the floor stability could be evaluated. Six cribs spaced along the length of the recovery room were fitted with flat-jack load cells placed between the top of the concrete crib and the bag so that actual crib loads could be measured. To complement the crib loading behavior, metal datum pins were driven into the concrete cribs and bags so that the actual crib displacements could be determined. The crib support stiffness, an indication of performance and a key component for evaluation, could be determined by measurement of the crib load and displacement. Figure 5 shows the specific cribs that were instrumented and the cross-section

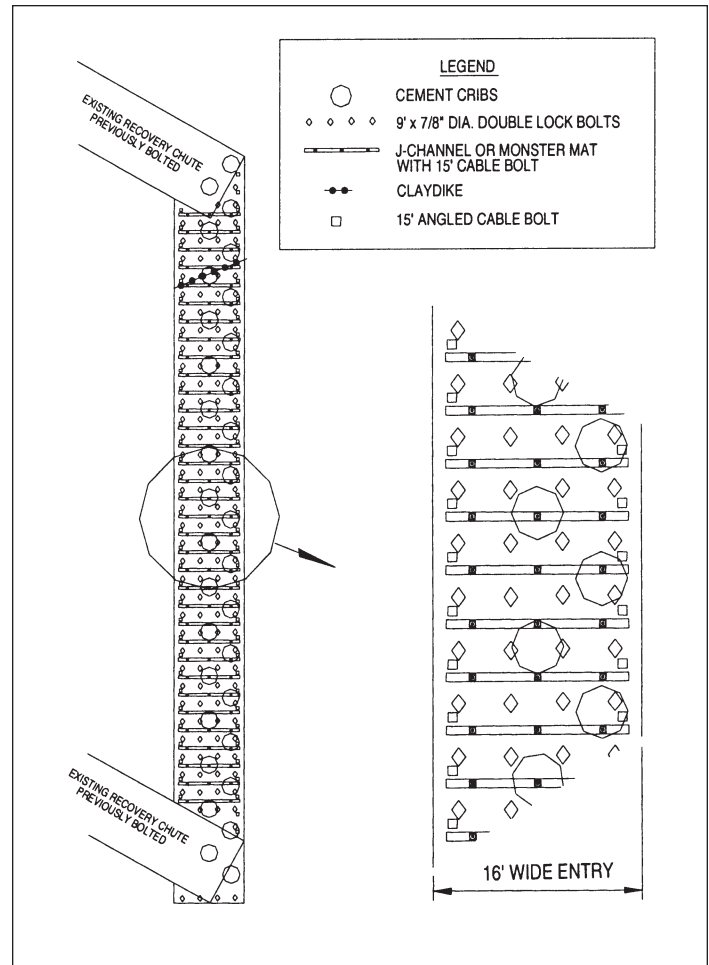

Figure 4. Plan view of the standing support and internal roof reinforcement system.

A-A illustrates the approximate measurement configuration. Individual shield loading was also monitored from the on-board computer at the stage loader area. The loads were transmitted by the data acquisition system transducers installed on the longwall shield legs. The shields had a working capacity of 650 tons. Figure 6 shows a photograph of a small zone of completed ribs, roof reinforcement, and instrumentation.

TEST SITE RESULTS

The area had been driven, reinforced, and the crib pouring took place 39 days or 1,100 ft before the longwall face was to enter the area. This allowed for proper curing of the concrete materials. The instrumentation package was completed with the installation of the differential sag-stations when the longwall face was 980 ft inby the recovery room. The data were read and evaluated on a weekly basis until the face was within 200 ft, and then the data were read daily. When the face was within 100 ft, the test instrumentation was read every shift. For the final 50 ft, personnel continuously monitored the instrumentation and documented roof, pillar, and crib behavior until the longwall safely entered the recovery room. The actual roof-to-floor closure was limited to a maximum of 1.50 inches when the longwall face was approximately 16 ft from entering the room. The differential sag-station located in the same area recorded that only 0.40 inches of the movement was attributed to roof separations and the remaining 1.10 inches was the result of floor heave.

¹ Mention of specific manufacturers or products does not imply endorsement by the National Institute for Occupational Safety and Health.

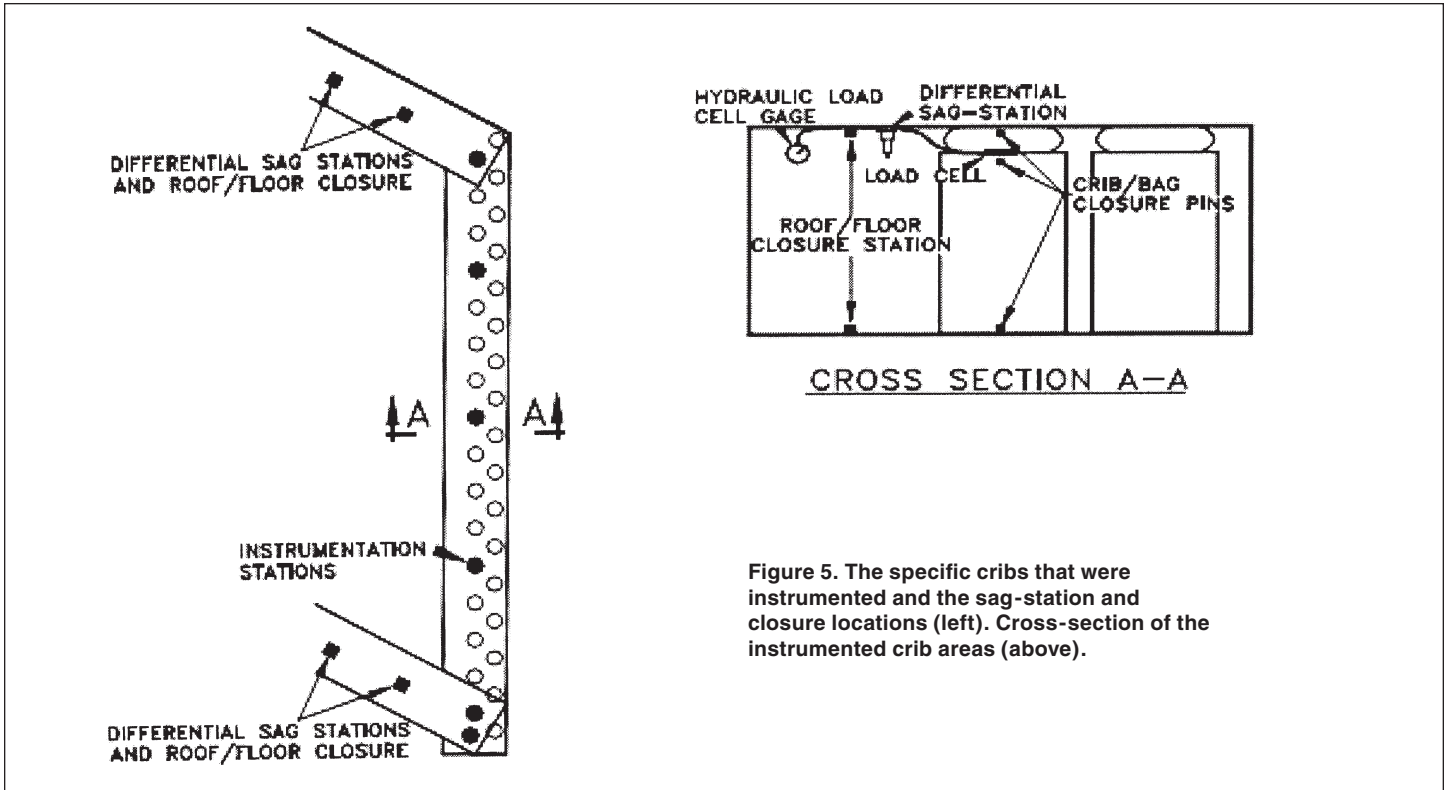

Figure 5. The specific cribs that were instrumented and the sag-station and closure locations (left). Cross-section of the instrumented crib areas (above).

The greatest measured crib load was approximately 1,000,000 lbs. This load, coupled with the crib displacements, results in a stiffness calculation for the concrete crib and the bag of 1.69×10^6 lb/inch. This value is significant because it represents an indication of the resistance to load. While this stiffness helped minimize roof closure and movement, the stiff material properties may have caused the cribs to fail in a brittle mode as shown in Figure 7.

While a traditional bolting system probably would have little value in preventing a weighting failure, it does provide significant confinement and prevents roof falls in weak roof conditions. When supplemented with the



Figure 6. Photograph of completed cribs, roof supports, and instrumentation.

longer high-capacity cables, especially between the inby side rib of the recovery room and the shield tips, it appeared that only minor loading was transferred from the roof to the cribs. The walk or travel way between the center cribs and the outby side rib remained open and no falls occurred along the entire length. The roof yield zone identified in the model was supported with the primary bolts and the angled cables. Based on the differential sag-station data it appeared that the cables were successful in suspending the lower roof members bound by the tensioned roof bolts. The total roof bolting system, with a calculated reinforcement index of 487 psi ft was effective but highly conservative. The number and lengths of the bolts and cables were more than adequate in this case. For future applications, the bolting system should be evaluated for specific roof strengths as well as tectonic and gravitational forces. The support on the inby and outby ribs of the recovery room proved to be extremely successful in controlling rib spalling and sloughage throughout the mining process. The rib support systems provide confinement to the outby pillar and the inby panel fender, which may have increased the residual pillar strength and minimized the respective pillar yield zones.

POST LONGWALL RECOVERY ANALYSIS

An additional benefit of a 3-dimensional finite element model is the ability to calibrate the sub-model with actual field data to assist with a parametric or "what if" behavior scenarios. These can include altering the crib spacing, over-burden depths, and crib stiffness. The behavior of the pre-driven recovery was analyzed with no cribs and compared to the cribs placed on the 10-ft staggered spacing. The horizontal, vertical, and shear stresses were determined and resolved into displacements, plastic deformation, and subsequent bolt and crib load. The complete analysis is presented in *Tadolini, 2003*.



Figure 7. Brittle crib failure prior to the longwall entering the recovery room.

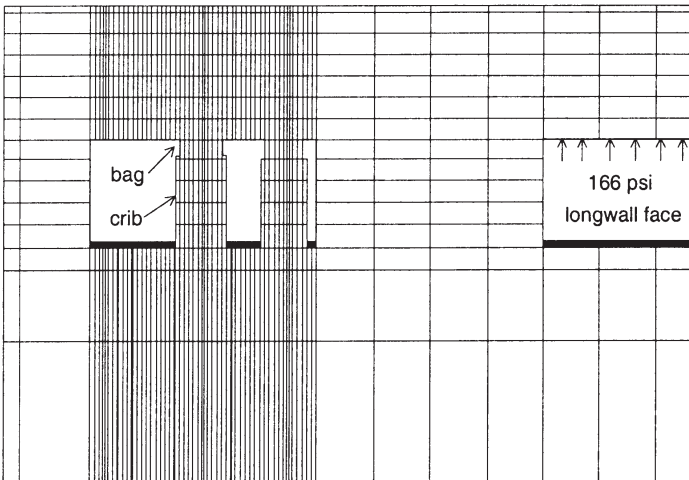

Figure 8. Cross-section of the recovery room entry.
Note shield pressure and crib locations.

Sub-Model Results with Bolts Only-No Cribs Installed

The first series of models examine the behavior of the pre-driven longwall recovery room with no standing concrete cribs installed. The resistance to closure and loading is only provided by the primary resin-assisted tension bolts and the cable bolts. The resin-assisted bolts are installed with 9 tons (18,000 lbs) of pre-tension and the entry has supplementary cables installed between the rows with 1 ton (2,000 lbs) of active bearing plate load. The cross-section of the sub-model and the plan view of the bolting support plan are presented in Figures 8 and 9 (both Figures show the location of the cribs for the next phase of the analysis). The longwall is moving into the recovery room from right to left and the longwall shields are exerting 166 psi on the roof immediately above the contact area.

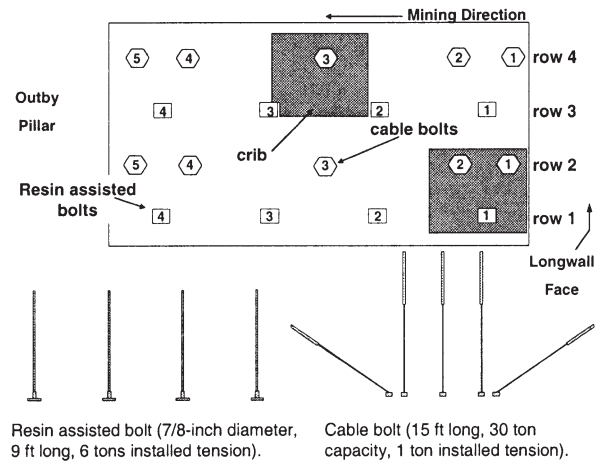

Figure 9. Plan view of the bolt locations and cross-section of the applied bolting systems.

As the longwall approaches the test area where the fender pillar is 16 ft wide, the bolt loads were determined and the roof movement at the center of the 16-ft wide recovery room was calculated. The computer model determined a roof movement or displacement of 3.00 inches. The individual bolt and cable loads are presented in Table 1.

Table 1. Individual bolt loading in pre-driven entry with no cribs. The longwall panel is 16 ft from entering the entry.

Bolt No.	Row 1 Tension Bolt Load (tons)	Row 2 Cable Bolt Load (tons)	Row 3 Tension Bolt Load (tons)	Row 4 Cable Bolt Load (tons)
1	23.2	17.9	23.2	17.9
2	23.4	13.5	23.4	13.5
3	14.4	8.9	14.4	8.9
4	9.4	3.2	9.4	3.2
5		-0.8		-0.8

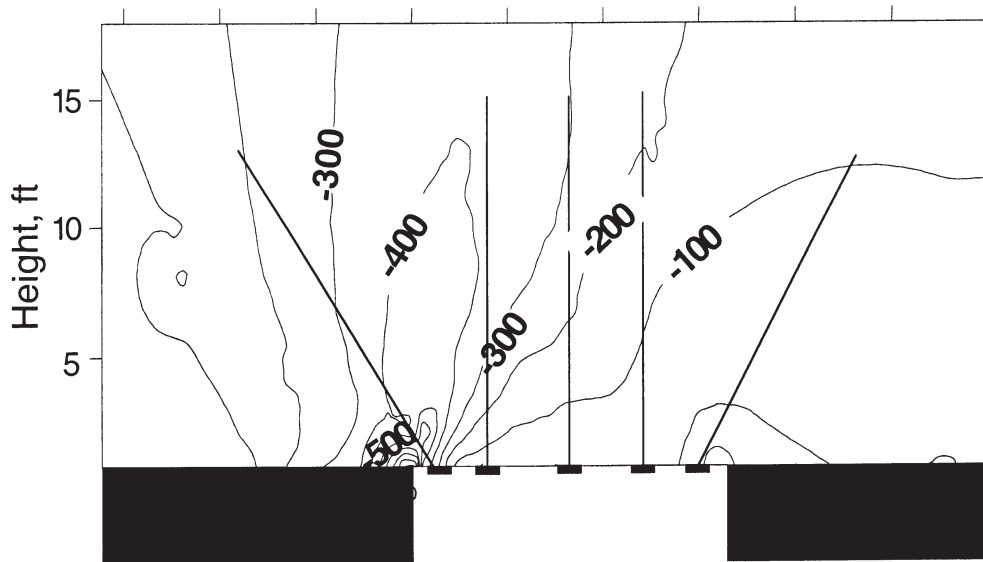

Figure 10. Shear stress distributions across row 1, resin-assisted tensioned bolts, over the recovery room. No cribs installed.

Stress Analysis: The 3-dimensional finite element model was used to determine the vertical, horizontal and shear stresses of the recovery room entry as the forward abutment load materializes on the roof and pillars that form the pre-driven recovery room. As expected, based on the concentration of the horizontal and vertical stresses, the highest shear stresses are located in the corner adjacent to the outby pillar. These shear stresses are capable of causing yield in the corner area that can extend into the immediate roof. The shear stresses in the roof area of the tensioned bolts in row 1 and the cable bolts in row 2 are shown in Figures 10 and 11. The maximum shear stress, approximately 400 psi, is exerted near the outby pillar edge.

Plastic Strain Deformation: The final phase of this analysis on the behavior of the pre-driven recovery room is probably the most revealing with respect to the permanent roof damage and the areas where falls can initiate and propagate. The stresses exerted on the roof are transformed to plastic deformation and contoured for analysis. Figure 12 illustrates the plastic strain in the roof for the area reinforced with the tensioned roof bolts. The plastic strains indicated highlight and area where permanent roof failure has propagated through the roof to a depth of 14 ft. As shown, this tensile roof failure is well above the 9 ft primary bolt length.

Sub-Model Results with Bolts and Concrete Cribs on a 10-ft Row Spacing

A sub-model was constructed to evaluate both the crib and bolt support behavior of the pre-driven longwall recovery room. This was the actual spacing used in the field study and the case used to calibrate the model. The concrete cribs were placed in a staggered row spacing of 10 ft as previously shown in Figures 3 and 9. The order of support placement was that the bolts were installed first and then the cribs poured. A crib can be placed underneath an intrinsic bolt support reinforcement which affects the individual bolt loads as shown in Figure 9.

Table 2. Individual bolt loading in pre-driven entry with concrete cribs on a 10-ft row spacing. The longwall panel is 16 ft away.

Bolt No.	Row 1 Tension Bolt Load (tons)	Row 2 Cable Bolt Load (tons)	Row 3 Tension Bolt Load (tons)	Row 4 Cable Bolt Load (tons)
1	12.8	10.0	11.2	9.6
2	11.3	2.1	4.1	0.2
3	7.5	0.8	3.8	-9.8
4	-7.4	-6.9	6.9	0.5
5		-0.8		-0.8

Note: Negative values indicate compressive bolt loads.

As the longwall approaches the test area, where the pillar fender is 16 ft wide, the bolt loads were determined and the roof movement realized at the center of the 16 ft wide recovery room was calculated. The roof displacement was 2.20 inches. The individual crib load was 960 tons. The individual bolt and cable loads are presented in Table 2.

As shown, the maximum loads of the primary tension bolts occur in the row nearest the outby abutment pillar. The maximum tension bolt load is 12.8 tons (25,600 lbs). The cable loading is also reduced dramatically by placing the concrete cribs into the support scenario. The highest load is 10 tons (20,000 lbs). As the longwall face pillar fender is mined, the reduced strength of the pillar the standing concrete crib supports help prevent roof displacements. When no cribs were installed and support was solely provided by the tension and cable bolts, the room closure was greater, 3.00 inches. When the concrete cribs are installed and the fender pillar is reaching the yielding state, the closure is reduced to 1.6 inches.

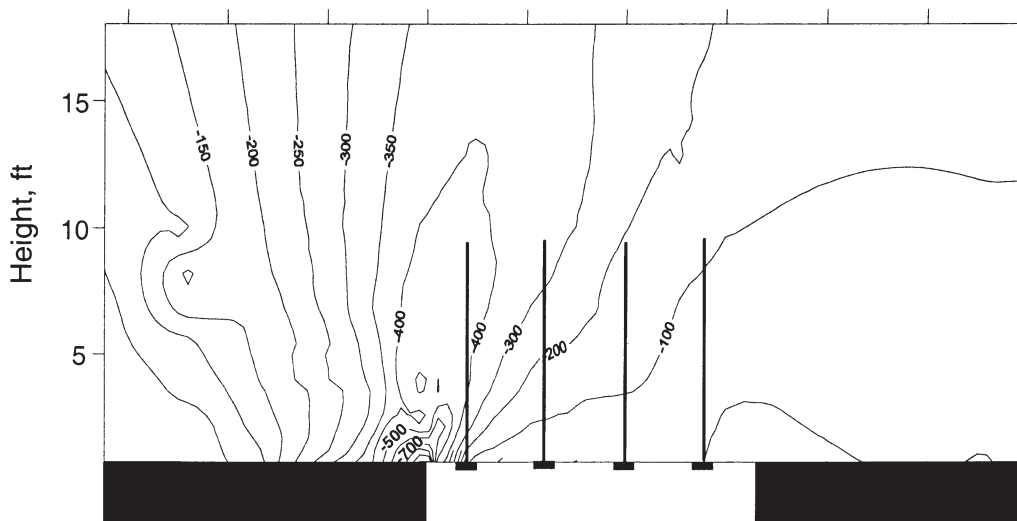

Figure 11. Shear stress distributions across row 2, cable bolts, over the recovery room. No cribs installed.

This large reduction is attributed to more load being carried by the crib system which reduced roof movement and subsequent separation. The plastic strains in the roof, when cribs were installed, were also analyzed to provide insight into prospective roof damage.

Plastic Strain Deformation: The plastic strain deformation was the final step of the analysis on the behavior of the pre-driven recovery room with concrete cribs installed on 10-ft row spacings. The stresses previously described were converted to plastic deformation and revealed the permanent “damage” that took place in the immediate and main roof structures. The plastic strain in areas of bolt rows 1 and 2 are shown in Figure 13 and 14, respectively.

As shown, a yielding zone developed in the immediate roof near the outby barrier pillar. It is interesting to note that the yielding across the roof areas reinforced with cable bolts is smaller than the zones reinforced with the tensioned bolts. This is because the cable bolts near the outby pillar accept the shear forces, which reduces the yield zone. Figure 13 indicates that small amounts of plastic strain are experienced slightly above the primary bolt horizon. The cable supports were designed to accept the additional loading of roof separations in the primary support horizon, these loads do not approach the design capacity of the cable systems if only vertical loads are applied. As the roof continues to move, the cribs have the capacity to accept additional loads and a redistribution of loads will take place. The area next to the outby abutment pillar appears to be a critical zone, even if standing concrete cribs are installed for support. The individual bolt loads are well within design capacities but the formation of plastic strains above the primary supports suggest that cable bolts may be critical for maintaining roof stability until the shields have safely entered the area.

MECHANISMS OF POTENTIAL FAILURE FOR PRE-DRIVEN LONGWALL RECOVERY ROOMS

As the longwall face approached the pre-driven recovery room, the front abutment loads are exerted over the fender pillar and onto the bolt system and standing supports in the recovery room. Under these conditions, the inby fender pillar would yield and the depth or distance of the yield zone would be dependent on the magnitudes of the abutment loads. As the inby fender pillar totally yields, the residual strength of the pillar is decreased to a fraction of the original intact strength. The intact strength is dependent on the width, height, and coal strength properties.

When the inby fender pillar is in a critical state of yielding, it is subjected to considerable front abutment pressures. As the inby fender pillar begins to yield and is reduced to 10% of the original intact pillar strength, the high abutment pressures *jump* over the recovery room and apply the forces to the outby abutment pillar, which can cause abutment pillar yielding.

As the inby fender pillar totally yields and is continually removed with the longwall shearer, the support capacity approaches zero and the remaining abutment pressure must transfer to the internal bolting support systems, the concrete cribs, and the outby abutment pillar. At that time, if the load on the cribs exceeds the crib capacity, they would fail and increase the likelihood that the roof could collapse into the entry.

The worst possible condition for a longwall equipment recovery occurs if the inby fender pillar collapses after yielding ahead of the longwall shields and the equipment is unable to enter the pre-driven room. When

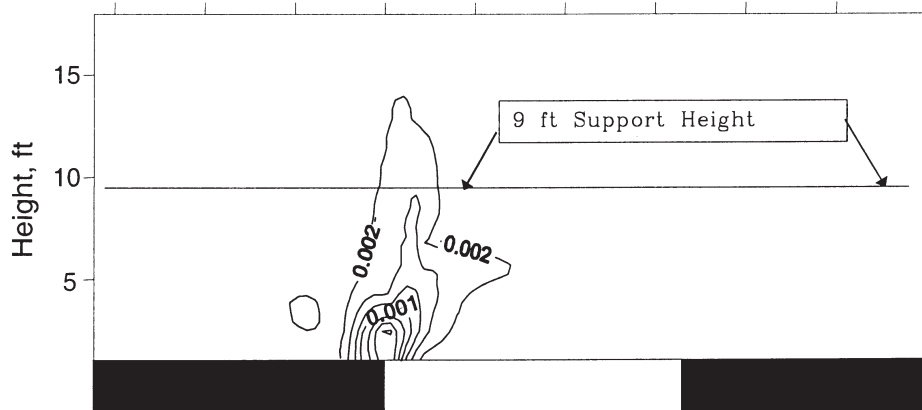

Figure 12. Plastic Strain distributions across row 1, resin-assisted tensioned bolts, over the recovery room. No cribs installed.

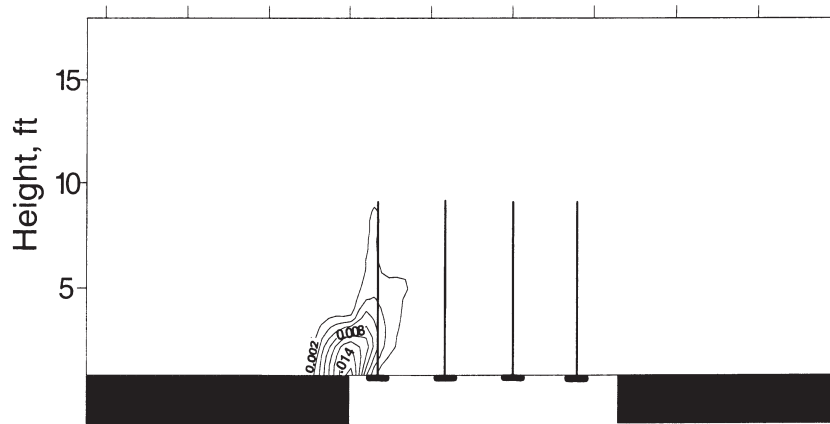

Figure 13. Plastic strain distributions across row 1, resin-assisted tensioned bolts, over the recovery room. Concrete cribs installed on 10-ft row spacing.

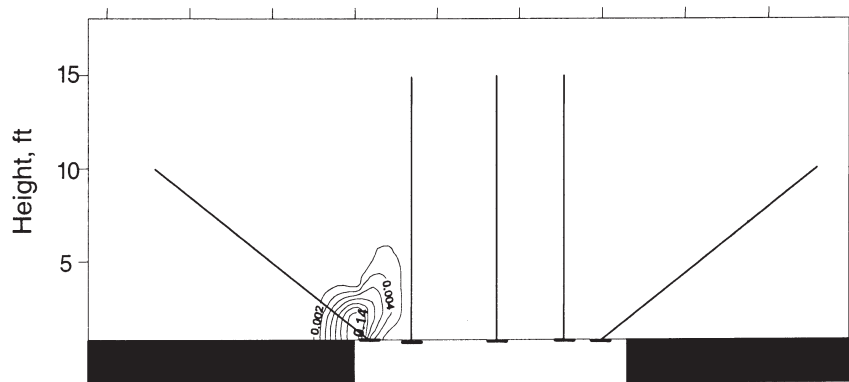

Figure 14. Plastic strain distributions across row 2, cable bolts, over the recovery room. Concrete cribs installed on 10-ft row spacing.

this occurs, the immediate roof above the inby fender pillar is largely unsupported and a roof failure onto the cribs and in front of the shields is likely. If the internal bolting reinforcement and any standing supports (concrete cribs, wooden cribs, props, etc.) collapse, the outby abutment pillar would be subjected to high loading and a new cave line can be formed near the outby pillar line by the increased shear stress concentrations and subsequent plastic deformations. The entire immediate roof could collapse making the equipment extraction very dangerous and nearly impossible.

EFFECT OF PRIMARY AND SECONDARY REINFORCEMENTS AND STANDING SUPPORTS ON THE STABILITY OF THE RECOVERY ROOM

As previously described, the primary roof bolt support reinforcement system is used to maintain the stability of the pre-driven longwall recovery room before the longwall approaches the area. Depending on the number and spacing of the bolts, the support density helps to maintain the local stability of the pre-driven recovery room during the initial mining process and secondary support system installations. As shown, some of these supports may end up above a concrete or wooden crib support and can be in compression once the roof movement develops that loads the cribs. These bolts serve no role in the final reinforcement scenario unless the cribs directly underneath should collapse and fail. The secondary intrinsic reinforcements, in this case cable bolts, are used to increase the reinforcement density to help resist roof movements and redistribute abutment pressures.

From the analyses presented, two areas of the roof are critical to assuring the stability of the pre-driven recovery room; the roof areas above the inby fender pillar and the outby abutment pillar. Because the roof yield zones have the potential to extend into the roof beyond the anchorage horizon of the primary bolts, cable bolts, or longer combination bolting systems should be used in the outby side of the recovery room to reinforce these areas. The cables provide reinforcement and are anchored high enough into the roof to be effective in the cases analyzed. The cable bolts installed vertically in the middle of the pre-driven recovery room provided only minimal support because much of the load was carried by the concrete cribs. This may have been a function of the installation tension and subsequent bearing plate loads.

CONCLUSIONS & RECOMMENDATIONS

The moving of longwall equipment from the completion of a current panel to the next set-up or start room remains a critical operation from both a safety and productivity perspective. Pre-driven recovery rooms can allow the safe and rapid retrieval of the longwall equipment, but history indicates that the support systems used must be carefully engineered, designed, and applied.

The pre-driven recovery room loading mechanism is complex. As the longwall face approaches the recovery room, the size of the fender pillar is reduced. The front abutment pressures are applied to the fender pillar, the recovery room roof, and the outby barrier pillar. As the longwall panel fender becomes thinner, the peak strength of the coal is reached and yield of the fender pillar begins. The abutment pressures, previously carried by the panel fender, transfer to the support systems installed in the pre-driven recovery room and onto the outby barrier pillar system. As the panel fender strength is reduced to a low residual strength and then eliminated completely by extraction, the abutment forces must transfer to the support system installed in the pre-driven recovery room and the outby abutment pillar system. The transfer phase of the large abutment loads can occur rapidly, loading the standing support and bolting

systems. The designs of these two components are critical for safe and efficient longwall equipment retrievals.

A field test area was established to evaluate a pre-driven longwall recovery room. A 3-dimensional finite element model ABAQUS was used to examine the stresses, deformations, and yield zones that may be encountered during the longwall mining extraction. A conservative design was applied at the test site based on the results of the model, an understanding of the weak roof and how it behaved under load, and a critical technical review of previous case studies.

Two rows of 48-inch diameter concrete cribs were poured in place with a concrete fill design specification of 3,500 psi. As described, several of the concrete cribs experienced brittle type failures caused by uneven loading near the crib edges. Even in this partially failed mode, the remaining strength of the cribs was sufficient to allow the safe entry of the longwall equipment system into the pre-driven recovery room.

Based on the instrumentation data obtained from the pre-driven recovery room and the field observations, the 3-dimensional ABAQUS model was calibrated. The calibrated model was used to evaluate the bolting and crib support systems. The loading of the bolts and cables near the outby pillar also confirmed the behavior observed in the preliminary test area and referenced in the literature.

As the longwall reduces the width and strength of the inby fender pillar, the immediate roof can start to deflect down and toward the edge of the failing fender pillar. This action creates tensile stresses and plastic deformation in the zone of roof near the outby barrier that loaded the primary bolt and cable system. In the test area, the crib systems were intentionally installed near the inby fender pillar and inside the centerline of the entry to restrict this rotational movement. However, as evidenced by the 3-dimensional finite element modeling and subsequent analyses, the bolting systems not directly reinforcing the roof near a crib may be subjected to higher loads and required to perform more of the work. Secondary cable bolts installed directly underneath or near cribs contributed very little toward maintaining stability. During the design process, the bolting system used must consider two distinct loading conditions; the immediate roof loads realized during the initial development and the heavy abutment forces applied to the supports during the longwall entry into the pre-driven recovery room. If the cribs are too stiff and experience brittle failure before the longwall panel can safely enter the pre-driven room, the bolting support system, particularly the longer high-capacity cable bolts, may play a vital role in maintaining the immediate roof and help resist main roof caving.

The results of this research can be summarized by the following suggestions for the initial design of a pre-driven longwall recovery room:

- √ Both standing cribs and cable bolts should be used in conjunction with the primary bolting system to support pre-driven recovery rooms.
- √ The row spacings of the concrete cribs are dependent on entry room width and overburden depth. Initial trials should be conservative to prevent weighting type failures. If two rows are selected, concrete cribs should be placed near the fender pillar and the outby abutment pillar. If only one row is selected, it should be placed near the fender pillar. These are the areas identified as highly susceptible to shear failures in the immediate roof and the zone critical for safe entry into the recovery room. The cribs also enhance pillar stability by providing confinement to the pillars as sloughed coal piles off and around the cribs.

- √ To supplement the crib supports, vertical cable supports should be installed between crib locations. The length should be long enough to extend beyond the predicted yield depth of the immediate roof.
- √ Angled cable bolts should be installed into the roof above the inby fender pillar and the outby abutment pillar to help support the immediate roof in the event of shear failures. This is particularly important if the immediate roof is classified as weak.
- √ It should not be necessary to install secondary cable supports or high-capacity roof bolts in locations where cribs will be placed. Under normal extraction conditions the standing support will alleviate the loading upon the roof and cable bolts. The caveat being if the cribs are not properly designed and fail before the longwall shields have entered the area, the existing secondary cable supports *will be* subjected to high loading. In this scenario, secondary cable bolts where cribs are placed could be beneficial.

Pre-driven longwall recovery rooms can be safely designed and used to extract longwall equipment. Combinations of intrinsic bolting systems and standing support must be used to cope with the potentials of roof fall and weighting type failures. This research effort concludes that the primary bolting system should be designed to minimize the potential of roof fall failures during the development cycle. The cribs and strategically placed cable bolts are a critical component to reduce the potential of weighting failures that can lead to a massive collapse of the roof before the longwall can safely enter the area. These support components have a

symbiotic relationship and assist each other throughout various stages of the mining process. Both are therefore prudent for a safe and successful longwall equipment recovery.

ACKNOWLEDGEMENTS

The authors would like to thank Dr. Yunqing Zhang for the assistance provided with the numerical modeling study presented in this paper.

REFERENCES

- Molinda, G. M. and Mark, C., 1994, "Coal Mine Roof Rating (CMRR): A Practical Rock Mass Classification for Coal Mines," U.S. Bureau of Mines IC 9387, 83 pp.
- Morsy, K. M. and Peng, S. S., 2002, "Evaluation of a Mine Panel Failure Using the Local Mine Stiffness Criteria - A Case Study," Transactions, Vol. 312, pp. 8-19.
- Oyler, D., Frith, D., Dolinar, D. R., and Mark, C., 1998, "International Experience with Longwall Mining into Pre-driven Rooms," Proceedings 17th International Conference on Ground in Mining, Morgantown, WV, Aug 4-6, pp. 44-53.
- Tadolini, S. C., 2003, "Ground Control Support Considerations for Pre-Driven Longwall Recovery Rooms," Ph. D. Dissertation submitted to College of Engineering and Minerals Resources, West Virginia University, Morgantown, WV, 163 pp.