

Effect of Three-Winding Transformer Models on the Analysis and Protection of Mine Power Systems

Mathew P. Oommen and Jeffrey L. Kohler, *Senior Member, IEEE*

Abstract—Computer-aided loadflow and fault analyses of mine power systems are routinely conducted to ascertain system performance and also to provide information to assist in the protection and coordination of these systems. Three-winding transformers are frequently encountered in mining applications, typically at continuous miner and longwall sections where there exists a need for dual utilization voltages. These transformers are often modeled as a three-bus system neglecting the secondary to tertiary winding impedance and the effect of base changes. This paper analyzes the impact of more accurate transformer models on voltages and fault currents which are realized from loadflow and fault studies of mine power systems.

Index Terms—Fault analysis, load flow analysis, power system analysis, power system modeling, transformer models.

I. INTRODUCTION

THE design of a mine power system should always be supported with computer analyses, including loadflow, fault, and machine starting. Engineers now have access to a variety of loadflow and fault analysis programs [1]–[3]. However, the availability of such tools does not eliminate the need for accurate system modeling. Oftentimes, these tools are used without an appropriate understanding of their capabilities and limitations.

System modeling is a key component in the proper evaluation of any power system. This, for example, includes the representation of cables, loads, correction devices, and transformers. The results from the analysis of mine power systems will only be as accurate as the model that is represented by the user. Most programs in use today can assist the user in easily specifying most of the components encountered in a mine power system. However, the representation of three-winding transformers and the effect of inaccurate models is not well understood in the context of mine power systems. The need for accurate representation is all the more important since more systems are utilizing dual voltages at longwall and continuous miner power centers.

Paper PID 98-01, presented at the 1993 Industry Applications Society Annual Meeting, Toronto, Ont., Canada, October 2–8, and approved for publication in the IEEE TRANSACTIONS ON INDUSTRY APPLICATIONS by the Mining Industry Committee of the IEEE Industry Applications Society. Manuscript released for publication February 17, 1998.

M. P. Oommen was with the Department of Mineral Engineering, The Pennsylvania State University, University Park, PA 16802 USA. He is now with Marston International, Inc., St. Louis, MO 63021 USA.

J. L. Kohler was with the Department of Mineral Engineering, The Pennsylvania State University, University Park, PA 16802 USA. He is now with the National Institute of Occupational Safety and Health, Pittsburgh Research Laboratory, Pittsburgh, PA 15236 USA.

Publisher Item Identifier S 0093-9994(99)03859-1.

Utilities have long appreciated the need for accurate transformer models. There is a variety of models one could use for intricate modeling of transformers to accurately delineate their performance under steady-state and transient conditions [4]–[6]. Unfortunately, mine power systems analysis, for the most part, has not considered the impact of even simpler representation and its effects on mine power system design and protection.

II. THREE-WINDING TRANSFORMERS

Transformer equivalent circuits are typically based on the parameters obtained from open- and short-circuit tests [7]–[9]. An approximate model is often obtained by neglecting the shunt admittance.

Both the primary and secondary windings of a two-winding transformer have the same kilovoltampere rating. However, all three windings of a three-winding transformer may have different kilovoltampere ratings. The impedances of each winding of a three-winding transformer may be specified as a percent or in per-unit based on the rating of its own winding, or could be referred to a common base.

In the case of three-winding transformers, the impedances may be measured by the standard short-circuit tests and could be represented as follows [10]:

- Z_{ps} leakage impedance measured in primary with secondary short circuited and tertiary open;
- Z_{pt} leakage impedance measured in primary with tertiary short circuited and secondary open;
- Z_{st} leakage impedance measured in the secondary with tertiary short circuited and primary open.

If these impedances are referred to the primary circuit, the impedances of each individual winding can be computed as follows [10], [11]:

$$\begin{aligned} Z_p &= \frac{1}{2}(Z_{ps} + Z_{pt} - Z_{st}) \\ Z_s &= \frac{1}{2}(Z_{ps} + Z_{st} - Z_{pt}) \\ Z_t &= \frac{1}{2}(Z_{st} + Z_{pt} - Z_{ps}). \end{aligned} \quad (1)$$

The individual impedances referred to the primary circuit are related to the leakage impedances as follows:

$$\begin{aligned} Z_{ps} &= Z_p + Z_s \\ Z_{pt} &= Z_p + Z_t \\ Z_{st} &= Z_s + Z_{pt}. \end{aligned} \quad (2)$$

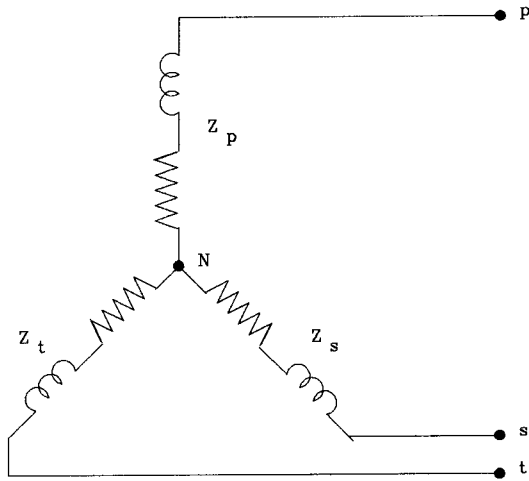

Fig. 1. Single-phase equivalent of three-winding transformer.

The impedances of the windings computed in (1) can be represented as a Y single-phase equivalent of the three-winding transformer with the magnetizing current neglected. This representation is shown in Fig. 1. The neutral point (N) is a fictitious neutral that has no physical meaning, but is necessary in the representation.

III. SYSTEM MODELING

In a computer-aided analysis of a mine power system containing a three-winding transformer, the points p, s, and t in Fig. 1 are connected to the buses designating the primary, secondary, and tertiary, respectively. However, in a system representation, the values of Z_s and Z_t must be referred to their individual kilovoltampere bases.

For example, given Z_{ps} , Z_{pt} , and Z_{st} referred to the transformer's primary kilovoltampere base (consistent with the respective winding voltages), one could apply (1) to compute values for Z_p , Z_s , and Z_t . These values, however, are based on the primary kilovoltampere rating.

Given that the kilovoltampere rating of the primary, secondary, and tertiary winding are kVA_p , kVA_s , and kVA_t , respectively, the following base transformations have to be made to prepare the model for computer analysis:

$$\begin{aligned} Z_s &= Z_s \left(\frac{kVA_s}{kVA_p} \right) \\ Z_t &= Z_t \left(\frac{kVA_t}{kVA_p} \right). \end{aligned} \tag{3}$$

This base change is necessary, since all impedances during analysis will be converted to a uniform system base.

Fig. 2(a) shows the often used inaccurate representation of three-winding transformers ignoring the second-to-tertiary impedance. Fig. 2(b) depicts the more accurate four-bus model developed in this section.

IV. SYSTEM ANALYSIS

The previous sections have introduced and developed the modeling aspect of three-winding transformers. However, to

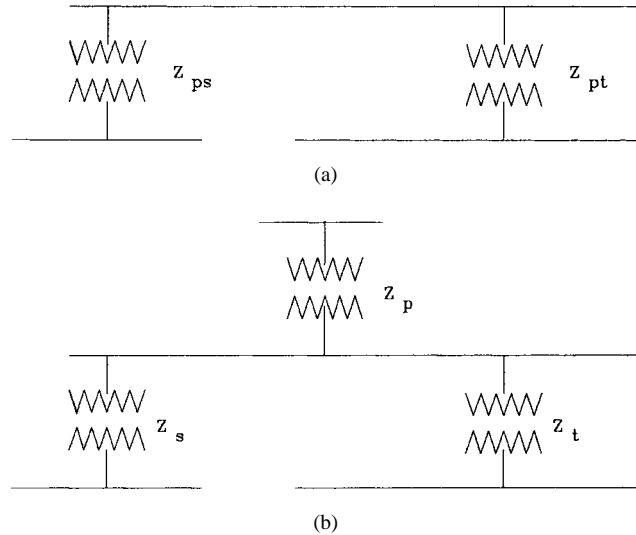

Fig. 2. (a) Inaccurate representation of three-winding transformer. (b) Correct three-winding transformer winding.

compare the two models, it is necessary to perform an analysis of a typical mine power system containing a three-winding transformer. Fig. 3 shows a typical longwall section employing a three-winding transformer.

The program used to evaluate the mine power system is called MPAP and was developed at the Mine Electrical Laboratory, The Pennsylvania State University, University Park. The program provides a single platform for performing loadflow analysis, symmetrical fault analysis, and first-cycle (transient) fault analysis. Details of the program may be found in [12].

The analysis was performed on three cases.

- 1) Case I is the base case, where the transformer is represented as a three-bus system, ignoring the secondary-to-tertiary impedance. Furthermore, it is assumed that Z_{ps} and Z_{pt} are not converted to their individual winding capacities (kilovoltamperes).
- 2) Case II also employs a three-bus representation, but the necessary base changes are performed to convert Z_{ps} and Z_{pt} to their respective kilovoltampere bases.
- 3) Case III uses the complete four-bus model of the three-winding transformer with the appropriate base changes.

In all cases, it is assumed that the manufacturer-specified values for leakage impedances are referred to the primary circuit of the transformer.

The values used for the analysis are as follows:

$$\begin{aligned} Z_{ps} &= 3.5\% (X/R = 4) \\ Z_{pt} &= 5.5\% (X/R = 6) \\ Z_{st} &= 3.0\% (X/R = 4). \end{aligned}$$

The utility short-circuit capacity is assumed to be 280 MVA at 7.2 kV.

A. Loadflow Analysis

Table I summarizes the results from the three cases. The values shown are percentage differences of Cases II and III as compared to the base case.

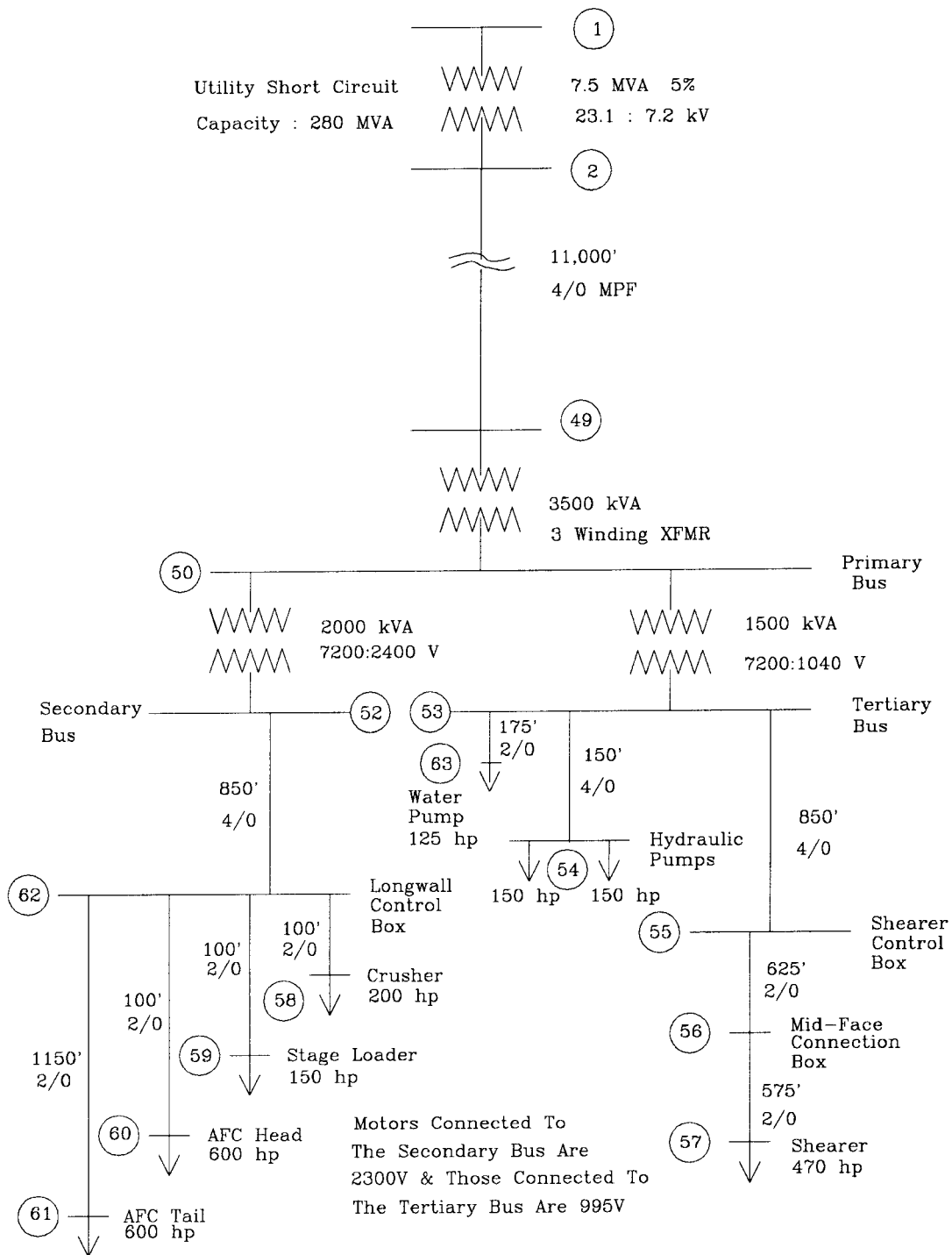

Fig. 3. Example of longwall power system.

Given voltage values V_1 , V_2 , and V_3 for Cases I, II, and III, respectively, the values in Table I were computed as

$$\left[\frac{(V_2 - V_1)}{V_1} \right] * 100 \tag{4}$$

for Case II, and as

$$\left[\frac{(V_3 - V_1)}{V_1} \right] * 100 \tag{5}$$

for Case III.

It can be easily seen that the relative change is minimal in both cases. There is, however, a small improvement in voltage regulation. This can be explained by the drop in line impedance between transformer buses due to the base change in Case II and due to the effective transformation to smaller impedances in the three-winding representation in Case III.

B. Fault Analysis

Table II shows the comparative results of symmetrical fault analysis, and Table III shows the results from symmetrical

TABLE I
PERCENTAGE INCREASE IN VOLTAGE MAGNITUDES
COMPARED TO INCORRECT MODEL IN CASE I

Bus	Case II	Case III
1	0.00	0.00
2	0.02	0.01
52	0.88	0.52
53	1.20	0.44
62	0.91	0.54
63	1.21	0.44
54	1.21	0.44
55	1.27	0.47
61	0.94	0.55
60	0.91	0.54
59	0.91	0.54
58	0.91	0.54
56	1.35	0.50
57	1.43	0.53

TABLE II
PERCENTAGE INCREASE IN SYMMETRICAL FAULT
CURRENTS COMPARED TO INCORRECT MODEL IN CASE I

Bus	Case II	Case III
1	0.00	0.00
2	0.00	0.00
52	24.87	26.32
53	59.88	61.45
62	17.65	19.01
63	38.44	40.03
54	45.73	47.28
55	19.36	20.25
61	10.47	11.57
60	16.74	18.09
59	16.74	18.09
58	16.74	18.09
56	9.88	10.44
57	6.61	7.02

fault analysis. These results are percentage changes referred to Case I as the base case.

Given fault currents I_1 , I_2 , and I_3 , for Cases I, II, and III, respectively, the values in Table II were computed as

$$\left[\frac{(I_2 - I_1)}{I_1} \right] * 100 \tag{6}$$

for Case II, and as

$$\left[\frac{(I_3 I_1)}{I_1} \right] * 100 \tag{7}$$

for Case III.

It can be seen that there is a significant difference that can be observed in Cases II and III. The most significant, in both tables, can be observed at the tertiary bus and the buses connected to it. Results show that the fault current can be higher by as much as 60% compared to the incorrect model in Case I. The results of the more accurate three-winding model are higher than those of Case II.

TABLE III
PERCENTAGE INCREASE IN FIRST-CYCLE FAULT
CURRENTS COMPARED TO INCORRECT MODEL IN CASE I

Bus	Case II	Case III
1	0.02	0.01
2	-0.10	0.20
52	16.48	25.04
53	42.08	58.94
62	10.61	15.89
63	27.79	36.48
54	32.38	42.93
55	10.89	14.30
61	4.70	7.48
60	10.12	15.08
59	10.16	15.13
58	10.15	15.12
56	3.34	4.80
57	0.82	1.59

The results directly affect the protection and coordination of such a system. For example, the main molded case breaker on the secondary and tertiary buses will be affected and so will the instantaneous settings for the distribution system overcurrent relays.

A similar analysis was performed on another longwall system to ensure that these results were not peculiar to the example under scrutiny. The analysis yielded results similar to those summarized in the above results.

V. TEMPERATURE EFFECTS AND HIGHER ORDER TRANSFORMER MODELS

The previous analysis used manufacturer-supplied data which is assumed to be for transformers operating at 170 °C. For a transformer at 20 °C, the X/R ratio is expected to be about 1.6 times higher than that at 170 °C. Therefore, it is necessary to consider this effect to determine the difference in maximum fault analysis.

An analysis, similar to that in the previous section, was performed to investigate the effects of temperature. Compared to the three-winding four-bus model, the values differed by 2% for two systems which were analyzed. These included the example system and the verification system.

Higher order transformer models can be utilized to incorporate the effects of mutual coupling across windings. These models are typically represented as impedance matrices [13]. These can then be incorporated into the system representation [14]. The development of such models requires more detailed information from manufacturers.

VI. SUMMARY

This paper has presented the impact of accurate, three-winding transformer models in the analysis of mine power systems. Although the disparity in voltage regulation is minimal, the enhanced representation of three-winding transformers seriously affects the results of both steady-state and first-cycle fault analysis. Fault current magnitudes could be underestimated by as much as 60% at strategic locations in the mine

power system. This directly affects the choice and sizing of protective and coordination devices used in mine power systems. The effect of winding temperature is also important, but the values do not vary too much from values computed for correctly represented four-bus three-winding transformer models.

Computer analysis of mine power systems is routinely utilized to analyze and evaluate mine power systems. Accurate system modeling of components in the power system is essential for proper analyses of these systems. The accurate modeling of three-winding transformers is critical, considering their widespread use in longwall and continuous miner sections.

REFERENCES

- [1] F. C. Trutt, L. A. Morley, and R. A. Rivell, "Interactive mine power system analysis, U.S. Bureau of Mines, Washington, DC, Tech. Rep. on Contract J0199060, 1981.
- [2] F. C. Trutt and L. A. Morley, "Mine power system analysis," *IEEE Trans. Ind. Applicat.*, vol. 24, pp. 839–845, Sept./Oct. 1988.
- [3] F. C. Trutt and J. L. Kohler, "A noniterative approach to mine power system analysis," in *Conf. Rec. IEEE-IAS Annu. Meeting*, 1984, pp. 113–116.
- [4] R. C. Degeneff and P. J. McKenney, "A method for constructing reduced order transformer models for system studies from detailed lumped parameter models," *IEEE Trans. Power Delivery*, vol. 7, pp. 649–655, Apr. 1992.
- [5] V. Brandwajn, H. W. Dommel, and I. I. Dommel, "Matrix representation of three-phase N-winding transformers for steady-state and transient studies," *IEEE Trans. Power App. Syst.*, vol. PAS-101, pp. 1369–1378, June 1982.
- [6] F. Leon and A. Semlyen, "Reduced order model for transformer transients," *IEEE Trans. Power Delivery*, vol. 7, pp. 361–369, Jan. 1992.
- [7] S. J. Chapman, *Electric Machinery Fundamentals*. New York: McGraw-Hill, 1985, pp. 66–70.
- [8] A. E. Fitzgerald, C. Kingsley, and S. D. Umans, *Electric Machinery*. New York: McGraw-Hill, 1985, pp. 45–48.
- [9] V. E. Mablekos, *Electric Machine Theory for Power Engineers*. New York: Harper & Row, 1980, pp. 29–31.
- [10] W. D. Stevenson, *Elements of Power System Analysis*. New York: McGraw-Hill, 1982, pp. 153–155.
- [11] *IEEE Recommended Practice for Power System Analysis*, ANSI/IEEE Std 399-1980, Nov. 24, 1980, pp. 65–66.
- [12] M. P. Oommen and J. L. Kohler, "An improved model for analyzing industrial power systems," in *Proc. 11th WVU Int. Mining Electrotechnology Conf.*, 1992, pp. 22–31.
- [13] M. J. Gorman and J. J. Grainger, "Transformer modeling for distribution system studies—Part I: Linear modeling basics," *IEEE Trans. Power Delivery*, vol. 7, pp. 567–574, Apr. 1992.
- [14] M. J. Gorman and J. J. Grainger, "Transformer modeling for distribution system studies—Part II: Addition of models to Y_{BUS} and Z_{BUS} ," *IEEE Trans. Power Delivery*, vol. 7, pp. 567–574, Apr. 1992.



Mathey P. Oommen received the B.Tech, M.S., and Ph.D. degrees in mining engineering from The Pennsylvania State University, University Park, in 1985, 1988, and 1994, respectively.

While at The Pennsylvania State University, he served as a Graduate Research Assistant from 1986 to 1994, a Teaching Assistant from 1989 to 1994, a Software Development/Support and Computer Consultant from 1991 to 1994, and he developed, distributed, and supported a computer program for mine power systems analysis while earning his advanced degrees. Upon graduation, he joined Marston & Marston, Inc. as a Project Mining Engineer. He is currently the General Manager of the Indonesia Representative Office, Marston International, Inc. Balikpapan, Indonesia, and is a past Senior Project Mining Engineer of Marston & Marston, Inc., St. Louis, MO.

Dr. Oommen is a member of the Society of Mining, Metallurgy, and Exploration.



Jeffrey L. Kohler (S'74–M'76–SM'88) received the B.S. degree in engineering science in 1974 and the M.S. and Ph.D. degrees in mining engineering in 1976 and 1983, respectively, from The Pennsylvania State University, University Park.

He worked as an Electronics Technician and then as an Electrical Engineering Assistant while an undergraduate. While working toward the advanced degrees, he was an Instructor of Mining Engineering at The Pennsylvania State University. From 1979 to 1982, he was a Senior Associate with Ketron, Inc. In 1983, he joined the faculty of the Department of Mineral Engineering, The Pennsylvania State University, where he was an Associate Professor and Director of the Mine Electrical Laboratory. His teaching and research interests included electrical engineering applications in the mineral industries. He is currently with the National Institute of Occupational Safety and Health, Pittsburgh Research Laboratory, Pittsburgh, PA, where he is Research Director.

Dr. Kohler is the Past Chairman of the Mining Industry Committee of the IEEE Industry Applications Society and a member of the Society for Mining and Exploration.