

sistence, and continued development of new methods and tools to add to those already at hand should put off the day of "doing without" for many years.

The possibility of resource exhaustion, especially in view of the long and increasing lead time needed to carry out basic field and laboratory studies in geology, geophysics, and geochemistry and to synthesize and analyze the information gained from them counsels against any letting down of our guard, however (17). Research and exploration by government, academia, and industry must be supported and encouraged; we cannot wait until an eleventh hour to mount a "crash program."

## Technological Insurance Against Shortages in Minerals and Metals

The Bureau of Mines has under way programs on recycling and more economical production of metals.

Ralph C. Kirby and Andrew S. Prokopovitch

The United States is faced with the challenge of producing more minerals and metals from lower grade resources.

The United States has an insatiable appetite for minerals. With but 6 percent of the world's population and only 6 percent of the world's land area, we consume 23 percent of the world's nonenergy minerals. In the last year and a half this pattern of usage has not changed appreciably. Stated in other terms, in the last 35 years we in the United States have consumed more minerals than all of mankind from the beginning of time up to about 1940. The forecast for the future is that in the next 25 years our mineral needs may triple. The supply is deteriorating steadily as demand increases, domestic high-grade ores are being used up, and other nations compete with us for world supplies. To meet this challenge requires a strengthening of U.S. metallurgical processing research and development efforts.

The nation has been a net importer of minerals since World War II. By the year 2000, we may be forced to get more than

half of our nonfuel mineral requirements from foreign sources unless we move to increase their availability from domestic sources.

The United States is dependent on imported manganese, chromium, aluminum, platinum, and many other minerals and metals (Fig. 1). For example:

1) We import 90 percent of our aluminum needs, and yet there are unlimited aluminum-bearing resources in the United States in the form of clay and anorthosite. Economically viable processes for recovering the alumina from these resources must be developed to reduce our reliance on imported bauxite.

2) We import 25 percent of our iron and steel requirements, and yet billions of tons of nonmagnetic taconites lie virtually untouched.

3) We import 85 percent of our fluorine requirements, and yet in the processing of phosphate rock we discard more fluorine than we use.

4) We import about 70 percent of our nickel, gold, and silver, and yet we have do-

### References

1. M. J. Carr, R. E. Stoiber, C. L. Drake, *Geol. Soc. Am. Bull.* **84**, 2917 (1973); S. Ishihara, T. Igarashi, C. Nishiwaki, *ibid.* **86**, 292 (1974); R. H. Sillitoe, *Nature (London)* **250**, 542 (1974); J. Kutina, *Miner. Deposita*, in press.
2. J. D. Lowell, *Econ. Geol.* **63**, 645 (1968).
3. D. J. Richards and F. Walraven, *Miner. Sci. Eng.* **7**, 234 (1975).
4. L. C. Rowan, *Am. Sci.* **63**, 393 (1975).
5. ———, P. H. Wetlauffer, A. F. H. Goetz, F. C. Billingsley, J. H. Stewart, *U.S. Geol. Surv. Prof. Pap.* **883** (1974).
6. R. G. Schmidt, *U.S. Geol. Surv. Open-File Rept.* **75-18** (1975) (see also the *Washington Post*, 22 Feb. 1975, for discussion in the United Nations of international implications).
7. I. Zietz, personal communication.
8. M. A. Chaffee, *U.S. Geol. Surv. Prof. Pap.* **907-B** (1975).
9. *Geological Survey Research 1974* [*U.S. Geol. Surv. Prof. Pap.* **900** (1975)].
10. E. Roedder, *U.S. Geol. Surv. Prof. Pap.* **440-JJ** (1972).
11. G. J. Rosasco, E. Roedder, J. H. Simmons, *Science* **190**, 557 (1975).
12. J. T. Nash, *Econ. Geol.* **66**, 1268 (1971).
13. S. R. Wallace, W. B. MacKenzie, R. G. Blair, *ibid.* **63**, 87 (1968); S. R. Wallace, *Trans. Soc. Min. Eng. AIME* **256**, 216 (1974).
14. S. R. Wallace, N. K. Muncaster, D. C. Jonson, W. B. MacKenzie, A. A. Bookstrom, V. E. Surface, in *Ore Deposits of the United States, 1933-1967*, J. D. Ridge, Ed. (American Institute of Mining, Metallurgical, and Petroleum Engineers, New York, 1968), pp. 605-640.
15. D. H. Richter, N. R. D. Albert, D. F. Barnes, A. Griscom, S. P. Marsh, D. A. Singer, *The Alaskan Mineral Resource Assessment Program* [*U.S. Geol. Surv. Circ.* **718** (1975)]; *U.S. Geol. Surv. Misc. Field Study Maps MF-655, A-L*, with texts.
16. E. T. Degens and D. A. Ross, Eds., *Hot Brines and Recent Heavy Metal Deposits in the Red Sea* (Springer-Verlag, New York, 1969).
17. *Mineral Resource Perspectives, 1975* [*U.S. Geol. Surv. Prof. Pap.* **940** (1975)].
18. P. W. Guild, in *Metallogenetic and Geochemical Provinces*, W. E. Petrascheck, Ed. (Springer-Verlag, Vienna, 1974), pp. 10-24.

mestic resources of these metals which also await the development of viable technologies for their exploitation.

5) We import 97 percent of our rutile requirements, and yet we have large deposits of ilmenite which could easily supply our titanium metal and TiO<sub>2</sub> pigment needs.

To overcome these dependencies, in part at least, it will be necessary to make real innovations and take major steps forward in exploration, mining methods and ore transport, processing low-grade resources, improved materials development, substitution and use, and secondary resource recovery. This will result in more efficient use of our resources and also will help ensure an adequate supply of mineral resources in the future.

### Bureau of Mines Program

The metallurgy activity has been an integral part of the Bureau of Mines since its formation when Congress established in the Department of the Interior a bureau of mining, metallurgy, and mineral technology. The need for this work has been confirmed by subsequent legislation. To execute the primary charter, the general purpose of the current metallurgy program of the Bureau of Mines is to help improve the nation's minerals and metals posture. Research and development are directed toward providing the scientific and technical information necessary to encourage and stimulate the nonfuel minerals industry to make the expeditious advances in technology that will encourage the private sector to produce an adequate and continuing supply of mineral raw materials at accept-

Mr. Kirby is chief of the Division of Metallurgy, Bureau of Mines, U.S. Department of the Interior, Washington, D.C. 20240. Mr. Prokopovitch is a staff metallurgist in the Division of Metallurgy.

able material and energy costs, and with a minimum of waste and environmental degradation.

The Bureau of Mines metallurgy program is oriented toward the accomplishment of the following objectives. Under "Advancing Minerals Technology," research is conducted that will result in major improvements in metals and minerals processing technology. "Minimizing Mineral and Metal Needs" covers research that will yield high-quality materials with improved performance and with increased service lives, which will result in more efficient use of our mineral resources.

The objective of "Secondary Resource Recovery" is developing methods for recovering metals and minerals from mineral and industrial wastes, for upgrading and refining these metals and minerals, and for developing uses for them.

Much of the metallurgy program addresses the problem of treating lower grade ores, recycling, and better utilization of resources. It reflects, too, the dominant influence of the supply situation, the patterns of energy consumption, and the impact of environmental constraints. Significant among the needs that this program is designed to satisfy are the development of: (i)

economic methods to recover minerals and metals from ore bodies of progressively lower grade; (ii) improved materials and metals that have reduced rate of deterioration and are suitable for use with high temperatures, in corrosive environments, or in other adverse conditions encountered in chemical and metallurgical applications; (iii) new or improved methods for preventing pollutants in the off-gas streams, liquid effluents, and waste products of mineral processing plants; (iv) new non-standard innovative methods of recovering metals and minerals that maximize efficiency and minimize pollution; (v) metallurgical processes that use less energy or use low-cost sources of energy; (vi) improved technology for increasing the proportion of our nation's minerals supply obtained through recovery and utilization of the valuable constituents in currently discarded scrap; and (vii) wider use of mineral materials that are abundant, and origination of substitutes for scarce minerals.

While the metallurgy program is designed primarily to meet long-term national needs, it is also concerned with current problems of broad scope that affect the nation's immediate mineral position. In many instances, industry, as groups or as individual companies, participates in cooperative cost-sharing projects to accelerate the work.

### Advancing Minerals Technology

*Nonmagnetic taconite iron ores.* The United States in the past was fortunate in having a large supply of high-grade direct shipping iron ore in the Lake Superior District deposits, the major sources of iron ore for the United States steel industry. These high-grade iron ore deposits, containing about 55 percent iron, eventually gave out and it became necessary to turn to the taconite ores which contain only about 35 percent iron. Magnetic taconites became the major domestic source of iron but were limited in extent and imposed limitations on expansion of production. To assure adequate supplies of iron ore to meet expanding needs in the years ahead, research was conducted to develop the technology for concentrating the much larger domestic resource of nonmagnetic taconite ores.

The Bureau of Mines attention to iron ore research has now focused on the vast nonmagnetic taconites of the western Mesabi range in Minnesota. In the past year, experimentation was started on an initial bulk sample of 350 tons of these taconites. The research included a pilot plant for flotation studies of the type and scale leading to the Tilden, Michigan, plant of the Cleveland Cliffs Iron Company (I).

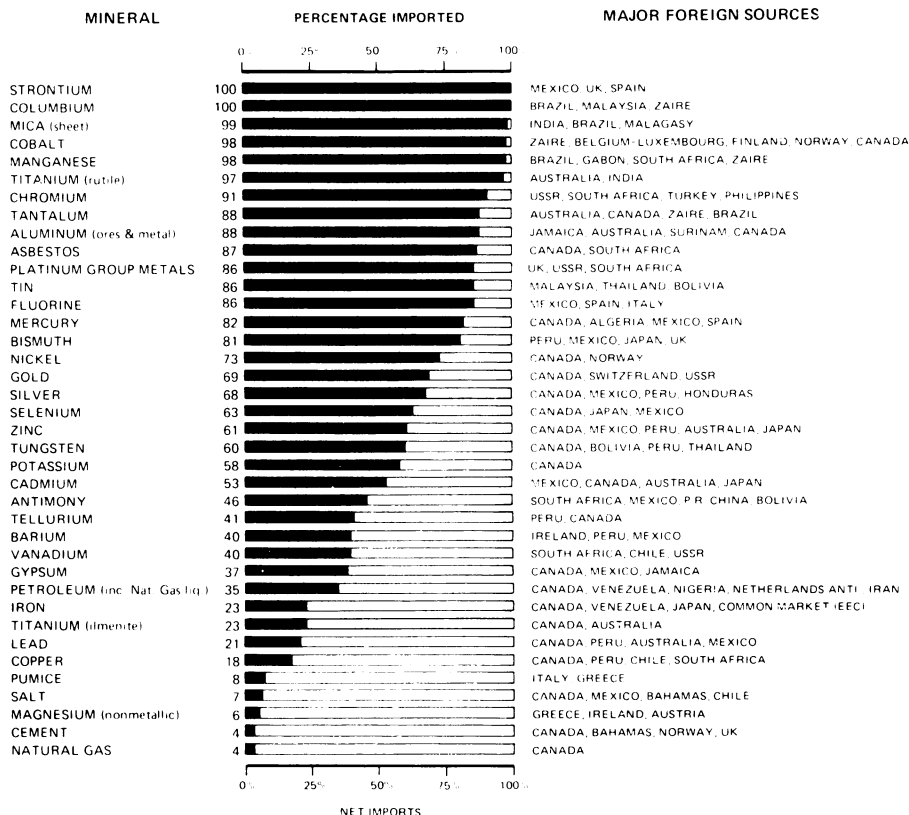

Fig. 1. Imports supplied a significant percentage of the total U.S. demand in 1974.

MATERIAL	FORMULA	% Al	% Al <sub>2</sub> O <sub>3</sub>	TONS/TON Al
ALUMINA	Al <sub>2</sub> O <sub>3</sub>	53	100	2
BAUXITE		25	47	4
Boehmite	Al <sub>2</sub> O <sub>3</sub> ·H <sub>2</sub> O			
Diaspore	Al <sub>2</sub> O <sub>3</sub> ·H <sub>2</sub> O			
Gibbsite	Al <sub>2</sub> O <sub>3</sub> ·3H <sub>2</sub> O			
CLAY		20	38	5
Kaolinite	Al <sub>2</sub> O <sub>3</sub> ·2SiO <sub>2</sub> ·2H <sub>2</sub> O			
SHALE	Impure clay	15	28	7
ANORTHOSITE		14	27	7
Albite	Na <sub>2</sub> O·Al <sub>2</sub> O <sub>3</sub> ·6SiO <sub>2</sub>			
Anorthite	CaO·Al <sub>2</sub> O <sub>3</sub> ·2SiO <sub>2</sub>			
ALUNITE	K <sub>2</sub> SO <sub>4</sub> ·Al <sub>2</sub> (SO <sub>4</sub> ) <sub>3</sub> ·4Al(OH) <sub>3</sub>	20	37	5
DAWSONITE	NaAl(OH) <sub>2</sub> CO <sub>3</sub>	19	35	5

Fig. 2. Alumina content of selected resources.

Alternative technologies for processing these resources, alone or in combination, are: (i) selective flocculation-cationic flotation; (ii) reduction roasting-magnetic separation; and (iii) wet high-intensity magnetic concentration. Pilot plant feasibility studies incorporating these three are planned for the roasted products so that economic comparisons can be made between the competing processes.

**Aluminum.** Although the United States produces about one-third of the world's aluminum, it must import 90 percent of the raw materials needed. Bureau of Mines forecasts of the aluminum situation show that U.S. demand for aluminum in the 1960's increased at an average annual rate of 9.4 percent, with a projected long-term growth rate of 6.5 percent, higher than that of any other metal. While there is no worldwide shortage of bauxite, the United States must increasingly compete with other industrialized countries also seeking reliable sources of supply at acceptable prices. The drastic increase in bauxite mining taxes imposed by Jamaica about 2 years ago, subsequent similar actions by other producers, and strong trends toward nationalization of mining operations add to the uncertainty of U.S. supplies. Furthermore, bauxite-producing countries are increasingly demanding that alumina ( $Al_2O_3$ ) plants and aluminum (the free metal) smelters be built in their own countries in order that they may export intermediate or end products of higher value and thus increase their revenues and provide jobs locally.

From the standpoint of national interest,

there is thus an urgent need to advance a technology that will allow the United States to make use of its ample domestic resources for aluminum production. For the long term, our reserves of bauxite are essentially negligible. On the other hand, there were, according to a 1967 report (2), more than 160 billion tons of alumina in the United States in sizable deposits of anorthosite, clay, laterite, shale, and low-grade bauxite (1). This report did not cover other resources that could become important to domestic alumina production—alunite, dawsonite associated with oil shale, and coal mine wastes. New, large deposits of alunite, overlooked in previous explorations, have recently been reported. Dawsonite's potential rests with the development of oil shale as a major energy source, and doubling coal production will produce large quantities of mining wastes containing both alumina and unrecovered coal.

For more than 50 years the Bureau of Mines has been involved in research on methods of extracting alumina from domestic resources. As an important part of this work an extensive series of cost and technical evaluations was prepared of extraction processes developed both within and outside the Bureau. These studies showed that none of the proposed processes was competitive with the Bayer process. The alumina content of some of the resources being considered is shown in Fig. 2.

Three principal factors contributing to the higher cost of alumina from domestic resources are: (i) nonbauxitic sources contain less alumina (typically 25 to 30 per-

cent  $Al_2O_3$ ) than bauxite (about 50 percent  $Al_2O_3$ ) and contain more gangue materials; (ii) processes for domestic resources are more complex and require high-cost materials of construction; and (iii) the processes for treating nonbauxitic materials require at least twice as much energy per ton of alumina as the Bayer process. Figure 3 shows block diagrams comparing the Bayer process with acid leaching of clay. Figure 4 shows the miniplant that was designed to treat approximately 70 pounds (1 pound = 0.45 kilogram) of raw material per hour from domestic resources, and to obtain data for designing a larger pilot plant for the most promising technique. In January 1974, invitations were issued to companies having U.S. smelting facilities to join the Bureau of Mines in a cooperative, cost-sharing effort. Ten companies have responded: Aluminum Company of America; Aluminum Company of Canada, Ltd.; Alumax, Inc.; Anaconda Aluminum; Combustion Engineering, Inc.; CONALCO, Inc.; Kaiser Aluminum and Chemical Corp.; Martin Marietta Aluminum, Inc.; Reynolds Metals Co.; and Vereinigte Aluminium-Werke AG. The Bureau of Mines also has bilateral agreement on this project with the Canadian Centre for Mineral and Energy Technology.

Nitric acid leaching of clay was the first process tested in the miniplant project. Calcined clay is leached with hot nitric acid, and the solution containing aluminum nitrate is separated from the solids, which are washed and discarded. Iron is removed from the solution by solvent extraction, and the purified solution is evapo-

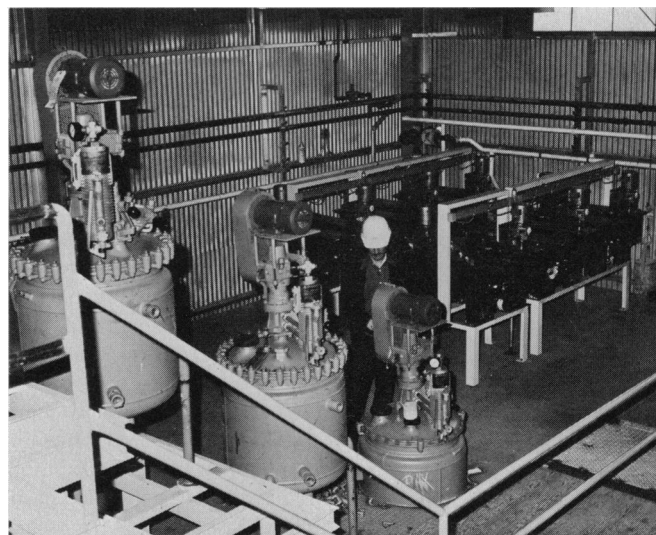
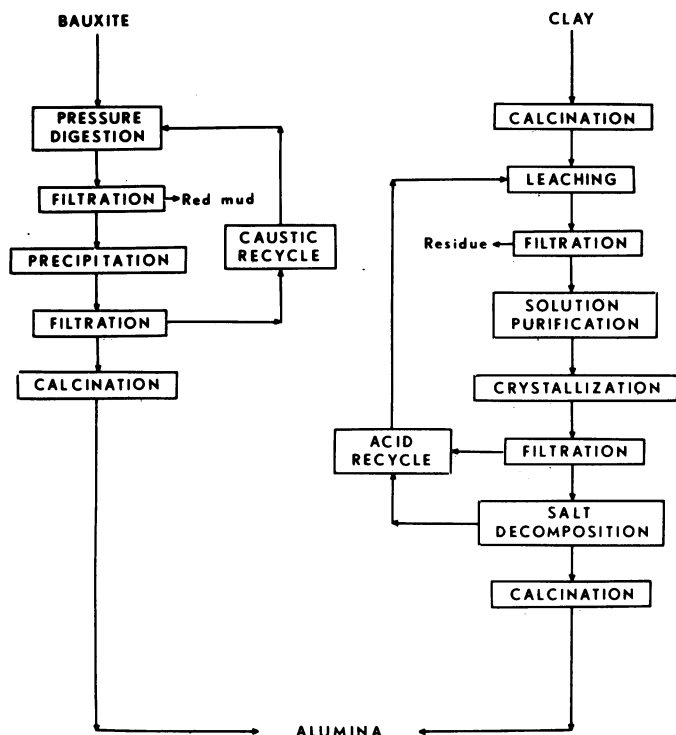

Fig. 3 (left). Comparison of methods for recovering alumina from bauxite or clay. Fig. 4 (right). Miniplant operated by the Bureau of Mines for determining the amenability of various nonbauxitic raw materials for alumina production. The research is being performed at the Bureau's Boulder City Metallurgy Research Laboratory under a cost-sharing cooperative agreement with ten private companies.

rated to crystallize aluminum nitrate non-hydrate. The latter is thermally decomposed to alumina and nitric acid for recycling. The thermal decomposition step is a major problem in this process because energy consumption is high and heat transfer is difficult.

The second miniplant, now under construction, will process clay with hydrochloric acid. The process is similar to the clay-nitric acid process, except that aluminum chloride hexahydrate is the salt crystallized. Because of the lower water of crystallization, energy consumption is reduced; but requirements for materials of construction are more difficult to meet than for nitric acid processing. An alternative to evaporation-crystallization is to precipitate the aluminum chloride hexahydrate by sparging the solution with hydrogen chloride gas. There are indications that this may reduce energy consumption even further.

Anorthosite is our largest single alumina resource, and its processing will be studied in the third miniplant to be built. Because of the large amounts of sodium and calcium oxides present, acid processing is not feasible, and lime-soda sinter or lime sinter methods must be used.

Sulfurous acid processing of clay will be the project of the fourth miniplant. Calcined clay is leached with sulfurous acid, and the solution is separated from the solids, which are washed and discarded. The aluminum sulfite solution is autoclaved under controlled conditions of temperature and pressure to precipitate a crude alumina, which is then purified by a modified Bayer process to cell-grade alumina. Sulfur dioxide liberated during autoclaving is recycled to the leach step.

Other potential sources of alumina include alunite, dawsonite, coal mining wastes, and coal fly and bottom ash. Vast quantities of these are available, and with increasing attention to coal as a source of energy they may become important as alumina resources in the near future.

**Nickel and cobalt.** The United States imports about 80 percent of its nickel needs. Value of imports exceeded exports in 1974 by nearly \$400 million, and the deficit is projected to reach \$1 billion by the year 2000.

The United States has about 7 billion tons of low-grade nickel-copper sulfide resources averaging about 0.2 percent nickel, principally as gabbro in the Duluth, Minnesota, area. Recently, new surface deposits of nickel laterites have been identified in southwest Oregon and northwest California, amounting to more than 400 million tons of ore containing about 0.7 percent nickel. Additional quantities are believed to exist at greater depths than those cur-

rently delineated. These new submarginal deposits could represent a major addition to the U.S. potential nickel supply. The Bureau of Mines is investigating new methods for treating both of these resources.

The Duluth, Minnesota, gabbro deposits contain cobalt in addition to copper and nickel; and to be economic a process must recover all three metals. A scheme now under study appears to have some promise. The ore is treated by flotation to recover a bulk sulfide concentrate of the copper, nickel, and cobalt. This concentrate is smelted to yield a matte which is leached in two stages with sulfuric acid. The first-stage leach, made at ambient pressure, selectively extracts the nickel and cobalt, leaving a residue containing the copper. The leach liquor is subsequently treated by solvent extraction and electrolysis to recover the nickel and cobalt, whereas the residue is leached at elevated temperature and pressure to obtain copper leach solution low in iron. The copper in this solution is then obtained by electrowinning. In tests to date, about 95 percent of the nickel and copper has been recovered from the matte by the two-stage procedure.

The lateritic material is not amenable to physical beneficiation and must be treated by a hydrometallurgy procedure. Such a procedure is being developed by the Bureau of Mines to selectively recover the nickel and cobalt. In laboratory evaluation of the process, the oxides in the laterite were selectively reduced with carbon monoxide at temperatures from 350° to 600°C. For material containing more than about 5 percent magnesia, pyrite addition or heat treatment after reduction was necessary to achieve satisfactory nickel and cobalt extraction for this range of reduction temperatures. Multistage leaching of the reduced material at ambient temperature and pressure in the presence of oxygen, ammonium sulfate, and ammonium hydroxide extracted up to about 90 and 85 percent of the contained nickel and cobalt, respectively.

The waste material from the laterites after removing nickel and cobalt contains a small percentage of chromium. Since the United States at the present time is completely dependent on imported chromium, the development of a satisfactory recovery process for the chromium in lateritic wastes would ensure at least a part of U.S. needs. At present, the Bureau of Mines is investigating the feasibility of recovering chromium from these lateritic wastes.

**Extraction of titanium from abundant domestic ilmenite.** The United States imports about 80 percent of its titanium needs and prices of rutile, the principal raw material used in the production of titanium

tetrachloride, have risen sharply as demands have taxed the limited supplies available. The United States has only marginal and submarginal deposits of rutile, but has large deposits of ilmenite. Because of the high iron content of ilmenite, its application as a feed for titanium tetrachloride is not generally feasible, since iron consumes expensive chlorine which becomes a waste disposal problem. Ilmenite is used extensively as raw material in the sulfate process for preparing titanium dioxide pigment, but here disposal of the large amounts of waste ferrous sulfate has been an increasingly troublesome problem. As pigment production capacity must be increased, new plants are invariably chloride process plants (with titanium tetrachloride being used as feed) that in turn put additional demands on rutile imports.

For a number of years the Bureau of Mines has been conducting research on methods of producing rutile substitutes from abundant domestic ilmenite.

A process that has been developed involves direct chlorination of finely ground ilmenite in a fluidized coke bed. Titanium tetrachloride and ferric chloride are recovered separately by fractional condensation of the off gases from the chlorinator. The ferric chloride by-product of the reaction is then reacted with oxygen gas in a separate fluidized-bed dechlorinator to yield ferric oxide and chlorine, which may be recycled to the ilmenite chlorinator. The by-product ferric oxide may be pelleted and used as blast furnace feed. The results of this project have been of interest to the titanium industry. Consideration is now being given to a cooperative, cost-sharing, large-scale pilot plant to facilitate technology transfer to commercial practice.

A novel "mineral synthesis" technique is used in another process in which ilmenite is smelted with coke and lime to produce pig iron and a high-titania slag. The slag is treated with titanium pyrophosphate as a fluxing agent, under oxidizing conditions, and then quenched. Rutile crystals then separate from the slag and are recovered after a leaching step with dilute sulfuric acid. A synthetic rutile containing about 90 percent TiO<sub>2</sub> is the final product. A preliminary cost evaluation shows promising economics for the process.

In a third process a carbonate-flux smelting technique is used to treat ilmenite; 99 percent of the titania is recovered as slag and more than 95 percent of the iron is recovered as pig iron. The titania slag is then leached to produce a low-iron sodium titanate intermediate product that can be used as a feed for the sulfate process, yielding titania pigment. Use of this flux-smelting technique to provide the sodium titanate for manufacture of TiO<sub>2</sub> pig-

ment eliminates the generation of large quantities of iron sulfate and the inherent problems relating to its disposal.

**Lead and zinc.** Lead and zinc smelters based on conventional pyrometallurgical technology cannot be built and operated economically on a small scale. Moreover, the increased costs of transporting ores and concentrates to a smelter limits production of lead and zinc from smaller mines. These factors have contributed to a decrease in U.S. overall production of lead and zinc. If full potential of our lead and zinc resources is to be realized, a more efficient process is needed capable of operating at small scale and at low cost.

The Bureau of Mines, therefore, is developing an aqueous chlorine leaching procedure combined with fused-salt electrolysis. The process is environmentally attractive and is effective in extracting nearly all of the metal values contained in sulfide concentrates (Fig. 5). Lead-zinc concentrates are chlorinated in aqueous slurry to produce lead chloride and elemental sulfur, and to solubilize metal values. After filtration, the residue is treated with hot brine to solubilize lead as the chloride. The lead chloride is crystallized from brine and dried. Lead and chlorine are recovered by electrolysis in a fused-salt bath; cadmium, silver, and copper are obtained from the leach liquor (which already contains zinc) by treatment with zinc dust, and the minerals are recovered by fire refining. The purified solution is evaporated to recover zinc chloride; the zinc and chlorine are then obtained by fused-salt electrolysis, and the chlorine is recycled.

**Phosphate and fluorine.** Resources of phosphate rock in the United States are estimated to be billions of tons. These resources could supply domestic demands for hundreds of years. However, if we consider only those resources which are exploitable by today's technology, production will decline sharply after 1985.

The most important phosphate resource in the United States is the Bone Valley Formation in Florida, where 100 million tons of ore are mined annually. This amounts to three-quarters of the domestic production and one-quarter of the world's production; however, large losses, of almost 40 percent, of phosphate minerals occur in the mining and processing of the ore. As yet this phosphate cannot be recovered economically with the technology available.

A promising long-term alternative is the direct digestion or acidulation of unbeneficiated Florida land-pegble matrix. Research thus far has shown that minus 20-mesh ore may be treated with sulfuric acid at 60°C in agitated, baffled vessels, with controlled throughput to allow the forma-

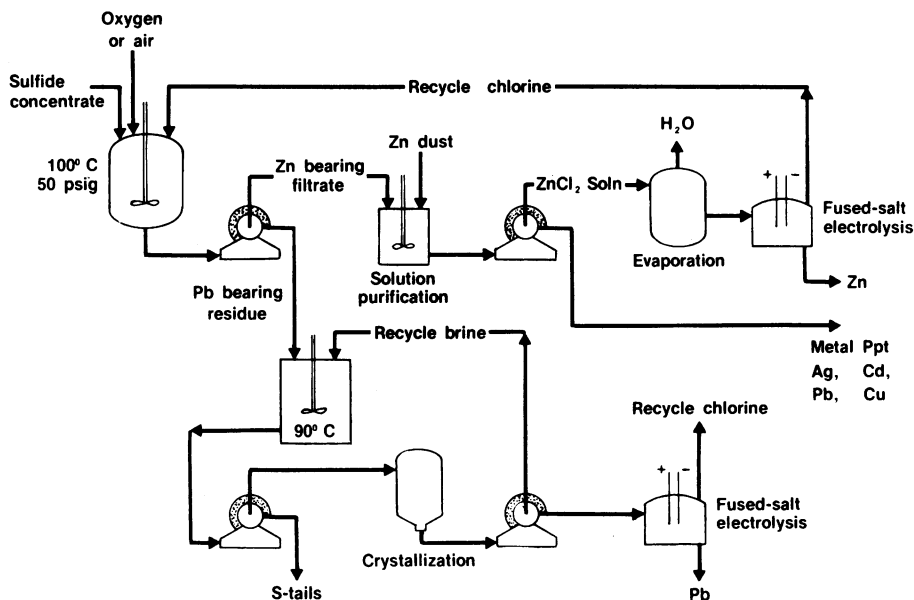

Fig. 5. Flowsheet for processing of lead-zinc sulfide concentrates.

tion of large, easily filtered gypsum crystals. Phosphate recovery is 95 percent, compared with slightly more than 60 percent by present technology, and the residue is a sandy, easily filtered material that can be used to backfill mined areas. However, acid consumption is a little higher; the phosphoric acid product is only 30 percent  $P_2O_5$ , and will have to be concentrated; and the alumina content of the product is somewhat high—but these problems do not appear to be insurmountable.

In cooperation with the Florida State Bureau of Geology, the Bureau of Mines has been characterizing the phosphate-bearing Hawthorn Limestone Formation that underlies the phosphate land-pegble region of Florida. The formation is estimated to contain 2 to 4 billion tons of  $P_2O_5$ , at a concentration of 5 percent, which is lower than the average of 14.7 percent  $P_2O_5$ , being mined domestically. The Hawthorn Formation is not being mined because of the lack of a suitable beneficiation procedure. However, the Bureau of Mines has been able to obtain concentrates containing up to 30.5 percent  $P_2O_5$ , with an attendant recovery of 81.5 percent of the phosphate by a fatty acid flotation process. These results indicate that this vast phosphate resource could be profitably utilized as raw material for phosphate fertilizer.

A companion problem is the recovery of fluorine values from the phosphate ore. The United States now imports 80 percent of the fluorspar it consumes annually, yet the fluorine content of the phosphate rock mined is more than enough to satisfy our needs, if it can be recovered. Most is now scrubbed out as fluosilicic acid and is discarded, or remains as contaminant in the product phosphoric acid. Bureau work has

shown how the waste fluosilicic acid may be converted simply to fluorspar. This involves (i) removing silica and other impurities by precipitation with ammonia, followed by filtration, and (ii) reacting the ammonium fluoride filtrate with lime to form fluorspar. Ammonia evolved is recycled back to the silica precipitation step. Alternatively, the fluosilicic acid may be converted to anhydrous hydrofluoric acid. Although this is somewhat more complicated than the conversion to fluorspar, yields are good and the product is of high purity.

Other work at the Bureau of Mines is focused on methods for more efficiently recovering the fluorine content of the phosphate rock. One approach which shows considerable promise is acidulation with recycle phosphoric acid, rather than sulfuric acid. The fluorine is mainly evolved in a single stream which may be easily recovered for further processing, as just described. Tests to date have shown that 95 to 98 percent of the  $P_2O_5$ , and more than 95 percent of the fluoride can be extracted by this method, and that 80 to 85 percent of the fluoride is evolved in the acidulation step. Current processes recover less than 50 percent of the fluoride in the rock.

**Copper.** The United States has large resources of copper, but the average grade of ore being mined is steadily declining as the more desirable deposits are worked out. Advances in technology are needed to make sure that our domestic resources can continue to be processed economically. Leaching of ore in place after fracturing is receiving increased attention. Because of the relatively high mining and beneficiation costs associated with working

## MAJOR

	SHORT TONS
IRON	32,000,000*
LEAD	508,000
COPPER	483,000
ALUMINUM	265,000
ZINC	106,000
CHROMIUM	54,000
NICKEL	34,000
TIN	12,900
ANTIMONY	22,400
MAGNESIUM	4,500

## MINOR

MERCURY	342
TUNGSTEN	250
TANTALUM	100
COBALT	240
SELENIUM	15

## PRECIOUS

SILVER	1,893
GOLD	21
PLATINUM GROUP	12

\*Includes Exports

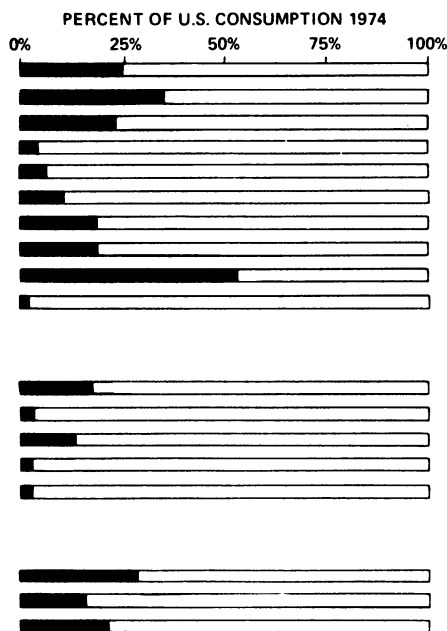

Fig. 6. Scrap metals recycled in the United States.

low-grade deposits, as well as the increasingly difficult problems of disposing of mining and milling wastes, the Bureau of Mines has been actively investigating in situ or solution mining techniques and is cooperating with industry to increase the efficiency of this technique for treating oxidized copper ores (1).

A significant development is the application of in situ leaching techniques at the Emerald Isle, Arizona, mine of El Paso Natural Gas Company. The company has been open-pit mining an oxide copper deposit and recently, in cooperation with the Bureau of Mines Salt Lake City Metallurgy Research Center and Twin Cities Mining Research Center, performed leaching tests on a 15,000-ton fractured ore sample at the floor of the pit. Copper has been recovered from the leach solutions by cementation.

**Uranium.** By 1990, the United States will be importing at least half of its uranium needs unless technology for recovering uranium at acceptable costs from low-grade domestic resources becomes available.

Because of the rapid depletion of our high-grade uranium deposits, future nuclear development will require the utilization of low-grade domestic resources containing less than 0.1 percent  $U_3O_8$  or dependence on foreign supplies (1). For this reason, the Bureau's research is concentrating on new and improved processes for the recovery of uranium from low-grade and refractory sources.

Virtually all of the uranium being extracted from domestic sources comes from sandstones of New Mexico, Wyoming, and

Utah. Until recently, uranium could be extracted from these ores by a simple dilute sulfuric acid leach at ambient temperature. Recovery of more than 95 percent of the uranium was common. Now, however, large mills are beginning to experience difficulty in dissolving this percentage of uranium from some of their ores because of interference from carbonaceous and sulfidic constituents. The Bureau of Mines is developing leaching procedures for treating these ores. The most successful procedure involves hot sulfuric acid leaching with the addition of nitric acid. Uranium extractions exceeding 90 percent have been attained from an ore by this method versus 25 percent for conventional leaching. In situ or solution mining techniques offer potential low capital and operating costs for treating these lower grade materials with a minimum of environmental problems. In situ leaching with sodium carbonate has been applied to an unconsolidated uraniumiferous ore body and leaching is being considered for sandstone using acid leaching. This technology is in its infancy, and at this time much more fundamental and engineering data must be developed before in situ leaching is broadly applied to uranium resources.

### Minimizing Mineral and Metal Needs

The increasing demand for materials of construction is a serious drain on the limited U.S. supply of minerals. A major portion of this demand originates from a need to produce replacement materials. For example, a substantial portion of the steel ca-

capacity in the United States is being used to replace corroded and rusted steels already in use. Nickel, cobalt, and other critical materials are used in high-temperature alloys that have short service lives. While longer lasting materials are needed for applications at both low and high temperatures, the alternative approach of developing domestically available substitutes or interchangeable materials would have a greater impact on reducing demand for critical materials and provide some insurance against shortages.

Minimization of mineral and metal needs by development of high-quality and improved-performance materials from abundant domestic resources, such as iron and molybdenum, will lead to subsequent reduction in the demand for scarce or imported materials in short supply. Among the several facets of the research at the Bureau of Mines on this objective are fundamental studies to determine the oxidation kinetics and the corrosion mechanisms of iron and iron-chromium alloys in order to provide the base from which better materials can be made and from which interchangeable substitutes can be developed. The corrosion problem alone is responsible for annual replacement of materials worth more than \$20 billion, most of it attributed to iron-base alloys.

The Bureau is using a unique approach in its study aimed at understanding the mechanisms of corrosion and passivation with respect to iron and iron-chromium alloys. This approach utilizes a linear ion accelerator in conjunction with advanced physical techniques, such as Auger electron spectroscopy. The techniques are being used to study the formation of ultrathin oxide and sulfide films on iron-chromium alloys at temperatures from 24° to 300°C and in atmospheres of  $O_2$ ,  $SO_2$ , and  $CO_2$ . Studies have been carried out during the initial stages of metallic oxidation and corrosion. In addition, measurements have been made of the diffusion rates of carbon, sulfur, and other impurities from the bulk of the metal to the surface where impurities can affect corrosion reactions.

Also, a new technique for preparing sample alloys is being developed. With the linear ion accelerator, alloying additions to pure metal samples are being implanted in precise quantities and well-defined geometries in the crystal lattices at metal surfaces. This technique makes it possible to evaluate metallic corrosion in a new and precise manner, and adds a new dimension to corrosion research. It also may herald a new method for producing bimetallic materials.

In order to provide alloys for use at high temperature, research workers at the Bureau of Mines have turned their attention

to iron, the only inexpensive alloy base that might fulfill the high-temperature requirements. Several techniques with potential for producing the essential properties are being examined. Emphasis is placed on incorporating ultrafine, refractory oxide particles in iron to strengthen it. Powder metallurgy techniques are utilized. The research has centered on ultrafine refractory oxide dispersoids because they retain the strength of metals to high temperature better than other types of strengthening mechanisms. Of the iron-strengthening techniques studied, internal oxidation, oxy-reaction, and powder blending methods produced the strongest alloys. These conclusions are based on stress-rupture tests at 800°C, the present target.

### Secondary Resource Recovery

*Metallurgical recycling as a partial solution to materials shortages.* The gap between our minerals and metals requirements and the remaining easily accessible world supplies is widening. As the nation's needs continue to grow and as per capita consumption of materials in other countries increases at an even faster rate than ours, it is becoming increasingly difficult for the United States to fill its ever-growing minerals deficit by primary domestic production and imports, even at increasing prices. A partial solution to this vexing problem is to increase our capability for recycling of minerals and metals contained in waste materials. Figure 6 illustrates the opportunities for increasing the recycling of scrap metals in the United States.

Bureau research is directed toward development of methods to recover the valuable mineral constituents in metallurgical wastes, and to improving the recovery and quality of the secondary resources being recycled. Widespread application of the results of this research should increase the portion of U.S. metal needs met by scrap. For example, the iron discarded in urban refuse is one of our most important low-grade metal and mineral resources, our only growing and renewable mineral resource.

*Stainless steel flue dusts.* For many years the Bureau of Mines has been concerned with the refining of secondary metals such as lead, zinc, copper, and brass. More recently, attention has been focused on recovering metals and minerals from a variety of unused or underused wastes to encourage more complete recycling.

An estimated 10 million pounds of chromium, 2.5 million pounds of nickel, and 250,000 pounds of molybdenum are lost each year in the wastes generated in the production of stainless steel. About 40 percent of this lost material is found in the flue dusts; the remainder occurs as mill scale and grinding swarf.

A treatment procedure has been developed for recovering over 90 percent of the metals from these wastes in an alloy containing 60 to 67 percent iron, 3 to 9 percent nickel, 9 to 17 percent chromium, and 0.25 to 4 percent molybdenum. This alloy can be recycled to the stainless steel furnaces.

The method consists of converting a mixture of flue dust, mill scale, grinding swarf, and coke breeze to pellets; a small quantity of Portland cement is used as a binder, and the pellets are reduced by preliminary heating in a furnace, followed by secondary reduction with ferrosilicon for more complete recovery of chromium. The process is versatile enough to accommodate a variety of charge ingredients with no adverse effect on the process. Zinc and lead, which are found in the flue dust, also are recovered as by-products in the form of oxide fume containing up to 40 percent zinc and 20 percent lead.

*Aluminum dross.* Another phase of metallurgical recycling is concerned with the waste dross and slag associated with primary production of aluminum. Large tonnages of aluminum-containing dross are generated annually by the aluminum industry, part of which is recovered in the secondary aluminum industry by a process in which large quantities of salt slag also are produced. The slag, containing fluxing salts, aluminum metal, and aluminum oxide, is currently disposed of by dumping. As a result, valuable metal and oxide are lost and the salts composing the flux can lead to pollution problems.

To reclaim the valuable slag constituents and eliminate the pollution problems, the Bureau of Mines had developed a hydrometallurgical process to recover the salt flux and most of the aluminum metal for recycling to the aluminum dross treatment furnace. The reclaimed aluminum oxide also has use as a constituent in preparing hot-top compounds and as a source of alumina for the cement industry.

Also, a method is being developed by the Bureau of Mines to recover metallic aluminum from dross without the objectionable salt slag being formed. In this method an inert atmosphere is used instead of a salt flux to protect the aluminum metal from

oxidation. Recovery of 80 to 100 percent of the aluminum metal contained in primary dross is effected by simply heating and stirring the dross in the inert atmosphere.

*Metal recovery from waste industrial solutions.* Waste solutions from industrial electroplating, etching, and pickling operations contain thousands of tons of valuable metals. In many cases the metal content of the waste solutions is greater than that of the primary ores now being processed. The lack of technology for treating plating wastes to recover metal values has encouraged the disposal of spent solutions to sewers and streams. Significant tonnages of the valuable metals can now be recovered with the Bureau's "waste-plus-waste" process, which can be successfully used to economically treat the major types of acid and alkaline plating wastes containing cadmium, chromium, copper, nickel, and zinc, and to treat both concentrated and dilute wastes. The process consists of the addition of an acid waste to an alkaline waste, in suitable proportions, so that at the optimum pH values of the mixtures, metals are virtually quantitatively precipitated. In the five waste-plus-waste combinations investigated, successful recovery of the metals always resulted. Also, the filtrate from the processing was relatively harmless compared with the original wastes and meets most water quality standards.

In summary, during the last three decades the United States has been a net importer of minerals, and the forecast for the future behooves us to implement a strategy of technologic insurance against shortages in minerals and metals by making real innovations and taking major steps forward in minerals processing and allied fields. To meet the challenge of producing lower grade domestic resources, the Bureau of Mines is conducting an integrated program for advancing minerals technology, minimizing mineral and metal needs, and improving the recovery of secondary resources for recycle. Although the program is designed primarily to meet long-term national needs, it is also concerned with current problems of broad scope that affect the nation's immediate mineral position.

### References

1. J. Rosenbaum, *Science* 191, 720 (1976). Rosenbaum discusses new developments and transfer of the developed technology to new industrial practice, while we attempt to depict the present and future role of research and development in meeting the long-term national needs.
2. "Potential Sources of Aluminum," Bureau of Mines Information Circular 8335 (U.S. Bureau of Mines, Washington, D.C., 1967).

## Technological Insurance Against Shortages in Minerals and Metals

Ralph C. Kirby, and Andrew S. Prokopovitch

*Science*, 191 (4228), • DOI: 10.1126/science.191.4228.713

### View the article online

<https://www.science.org/doi/10.1126/science.191.4228.713>

### Permissions

<https://www.science.org/help/reprints-and-permissions>