



SURFACE VEHICLE RECOMMENDED PRACTICE

J3057™

FEB2017

Issued

2017-02

Ambulance Modular Body Evaluation-Quasi-Static Loading
for Type I and Type III Modular Ambulance Bodies

RATIONALE

This SAE Recommended Practice was developed by members of the SAE Truck Crashworthiness Committee in support of the ambulance industry's need to apply science to the design and testing of the ambulance Modular Body for Type I, Type I-AD, Type III, and Type III-AD bodies. The Recommended Practice was validated collaboratively by industry and government partners through extensive testing funded and managed by the National Institute for Occupational Safety and Health, the Department of Homeland Security and the Ambulance Manufacturers Division of the NTEA. An independent analysis of the testing methodology and resulting data was performed by government and private members of the automotive and commercial vehicle testing community.

1. SCOPE

This SAE Recommended Practice describes the test procedures for conducting quasi-static modular body strength tests for ambulance applications. Its purpose is to establish recommended test practices which standardize the procedure for Type I and Type III bodies, provide ambulance builders and end-users with testing procedures and, where appropriate, provide acceptance criteria that, to a great extent, ensures the ambulance structure meets the same performance criteria across the industry. Descriptions of the test set-up, test instrumentation, photographic/video coverage, and the test fixtures are included.

2. REFERENCES

2.1 Applicable Documents

The following publications form a part of this specification to the extent specified herein. Unless otherwise indicated, the latest issue of SAE publications shall apply.

2.1.1 SAE Publications

Available from SAE International, 400 Commonwealth Drive, Warrendale, PA 15096-0001, Tel: 877-806-7323 (inside USA and Canada) or +1 724-776-4970 (outside USA), www.sae.org.

- SAE J211-1 Instrumentation for Impact Test - Part 1 - Electronic Instrumentation
- SAE J211-2 Instrumentation for Impact Test—Part 2: Photographic Instrumentation
- SAE J1727 Calculation Guidelines for Impact Testing
- SAE J1733 Sign Convention for Vehicle Crash Testing

SAE Technical Standards Board Rules provide that: "This report is published by SAE to advance the state of technical and engineering sciences. The use of this report is entirely voluntary, and its applicability and suitability for any particular use, including any patent infringement arising therefrom, is the sole responsibility of the user."

SAE reviews each technical report at least every five years at which time it may be revised, reaffirmed, stabilized, or cancelled. SAE invites your written comments and suggestions.

Copyright © 2017 SAE International

All rights reserved. No part of this publication may be reproduced, stored in a retrieval system or transmitted, in any form or by any means, electronic, mechanical, photocopying, recording, or otherwise, without the prior written permission of SAE.

TO PLACE A DOCUMENT ORDER: Tel: 877-606-7323 (inside USA and Canada)
Tel: +1 724-776-4970 (outside USA)
Fax: 724-776-0790
Email: CustomerService@sae.org
<http://www.sae.org>

SAE WEB ADDRESS:

**SAE values your input. To provide feedback on this
Technical Report, please visit
http://standards.sae.org/J3057_201702**

2.2 Other Publications

ECE R66 Uniform Technical Prescriptions Concerning the Approval of Large Passenger Vehicles with Regard to the Strength of their Superstructure

3. DEFINITIONS

RIGID MOVING BARRIER: A non-deformable barrier in the form of a platen attached to a rolling carriage intended to impart kinetic energy into the Modular Body during the dynamic pre-load test.

DYNAMIC TEST PLATEN: A structurally stiff, flat plate attached to the rigid moving barrier or other device used as a dynamic load input device.

BODY MOUNT: The production component or components used to connect the modular body to OEM chassis frame rails.

MODULAR BODY: A second-unit body installed by a final stage ambulance manufacturer as a patient compartment.

QUASI-STATIC PLATEN: A structurally stiff flat plate, with a length, width and, therefore, overall surface area that exceeds that of the roof and is used to evenly transfer the static test loading to the Modular Body.

CURB WEIGHT: The weight of the complete ambulance; chassis, cab, and body, including full complement of fuel, lubricants, and coolant.

QUASI-STATIC TEST: The quasi-static test applies a uniform force to the roof of the modular body using the quasi-static platen.

SIMULATED FRAME RAILS: A rigid test fixture to which the body mounts are used to attach the modular body.

4. REQUIREMENTS

The modular body strength testing is designed to evaluate the crush resistance, operation of doors, and body mount-to-frame connections in a 90-to-180° rollover accident. The loading is divided into two phases:

1. a dynamic pre-load that simulates the side loading on the roof rail of a modular body as it impacts the ground during a vehicle roll beyond 90°; and
2. a quasi-static roof strength test that simulates the loading on the modular body when the vehicle is inverted.

Both phases are conducted on a modular body attached to the same simulated frame rails using the ambulance manufacturer's body mounts.

To assist with the description of the modular body orientation and direction of motion, an SAE J1733 reference system is shown for the modular body relative to its original orientation on the vehicle. This is illustrated in Figure 1.

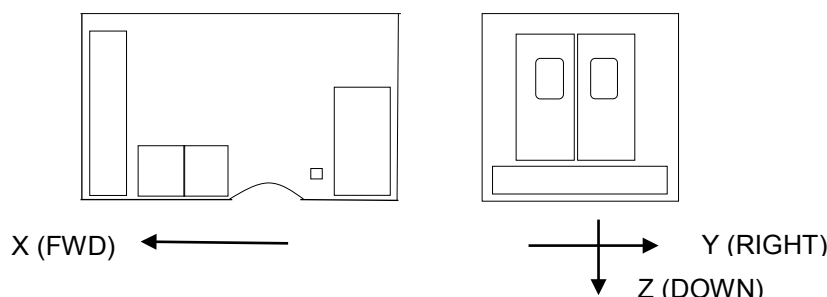

Figure 1 - Reference frame

- 4.1 The dynamic test platen attached to the rigid moving barrier shall be sufficiently rigid to meet the limits described in 7.4.
- 4.2 When under quasi-static loading during the roof crush test, the vertical displacement of the modular body shall not exceed the limits described in 7.5 when measured from ceiling-to-floor along the 4 locations of the body reference points, located at positions representing $25\% \pm 1\%$, and $75\% \pm 1\%$ of the overall length (OAL) and overall width (OAW) of the modular body, as illustrated in Figure 2.

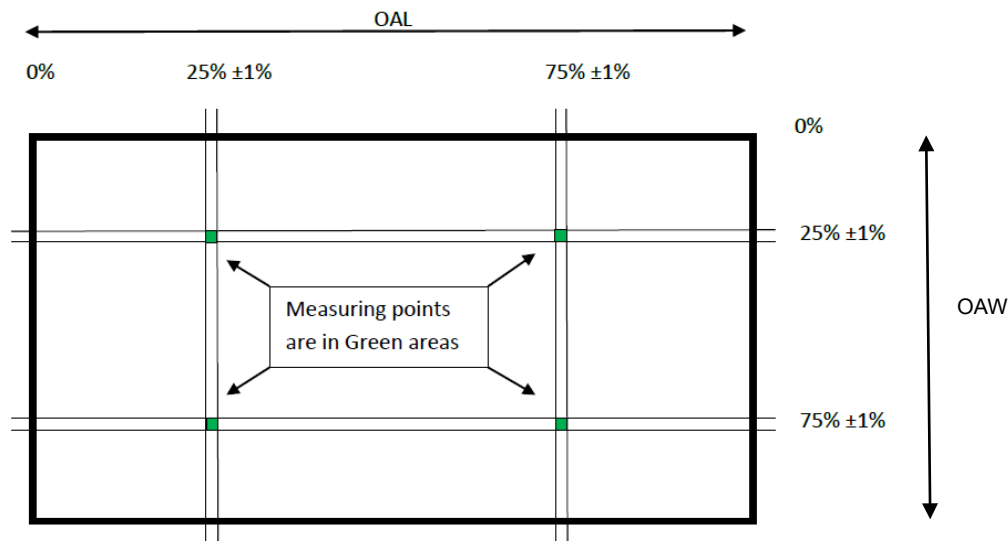

Figure 2 - Location of vertical displacement measurements

5. DYNAMIC PRE-LOAD TEST PROCEDURES

In the dynamic pre-load, the dynamic test platen attached to the rigid moving barrier impacts one side of the modular body, with the modular body mounted at an angle so that the dynamic test platen initially contacts the roof rail of the modular body. This test simulates roof edge impact to ground in a vehicle rollover.

Either side of the modular body may be loaded, depending on whether a driver side or passenger side leading rollover is to be simulated. However, if the modular body or its mounting is not symmetric, such that it may result in a strong or weak side, the weak side of the assembly should be evaluated.

- 5.1 The modular body shall be affixed to the simulated frame rails using the ambulance manufacturer's body mount system.
- 5.2 The simulated frame rails of the test modular body shall be affixed to the ground at a roll angle of $20^\circ \pm 1^\circ$.
- 5.3 The longitudinal axis of the modular body shall be perpendicular to the direction of travel of the dynamic test platen.
- 5.4 The dynamic test platen is oriented vertically.
- 5.5 The pre-load configuration is shown in Figure 3.

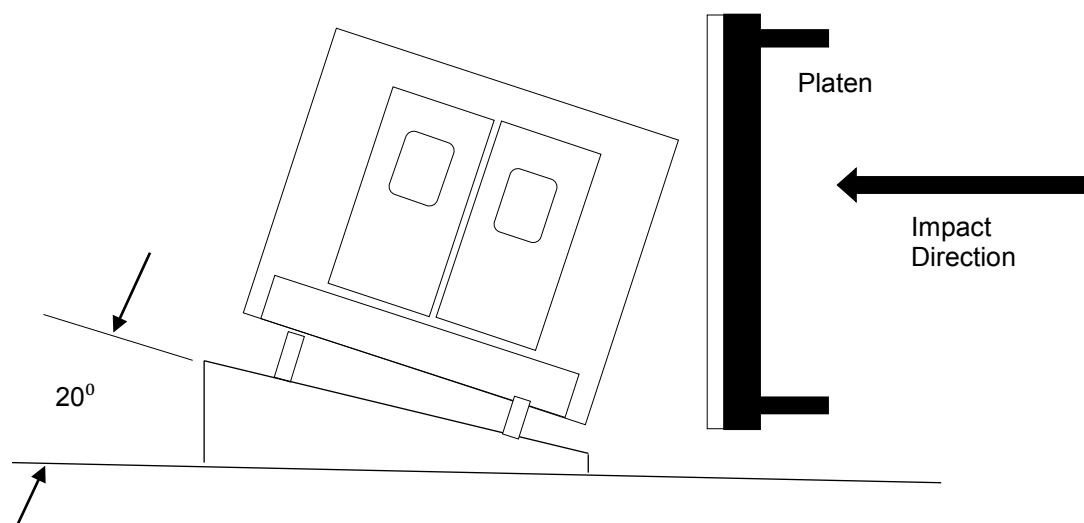

Figure 3 - Dynamic pre-load configuration

5.6 The target speed and design parameters for the dynamic test platen and its supporting structure is computed as described in 5.7.

5.6.1 For the pre-load phase of the test, the minimum energy level is 37965 Joules (28000 ft-lbf). The recommended minimum energy is based on measured results from an ECE R66 test of a typical, modern (2005 model year) type III ambulance. Manufacturers can, at their discretion, exceed this minimum energy level.

5.6.2 A rigid dynamic test platen shall be used to simulate the ground contacting the side of the modular body during a rollover event.

5.6.2.1 The dynamic test platen shall be sufficiently large and positioned such that the modular body will only be in contact with the mid-face of the dynamic test platen, not the upper or lower edge.

5.6.2.2 The width of the dynamic test platen should be sized such that it extends a minimum of 15.26 cm (6 inches) beyond the fore and aft ends of the modular body.

5.6.2.3 The face of the dynamic test platen is to be covered with a 19 mm (0.75 inch) thick layer of plywood. The dynamic test platen must be rigidly attached to the front of its carriage such that the assembly is a rigid moving barrier.

5.7 Rigid Moving Barrier

NOTE: This Recommended Practice was validated using a rigid moving barrier as the dynamic load input device. The design for dynamic load input device used during validation testing is provided as Figures 4 and 5 for reference. The dynamic input device had a weight of 14170 pounds, with a target velocity of 3.44 m/s (7.69 mph) and target kinetic energy of 37.96 kJ (28000 ft-lbf). The discussion that follows defines those parameters needed to reproduce the kinetic energy developed during the dynamic load test. However, other forms of dynamic pre-load are acceptable as long as they meet test conditions and energy levels described herein.

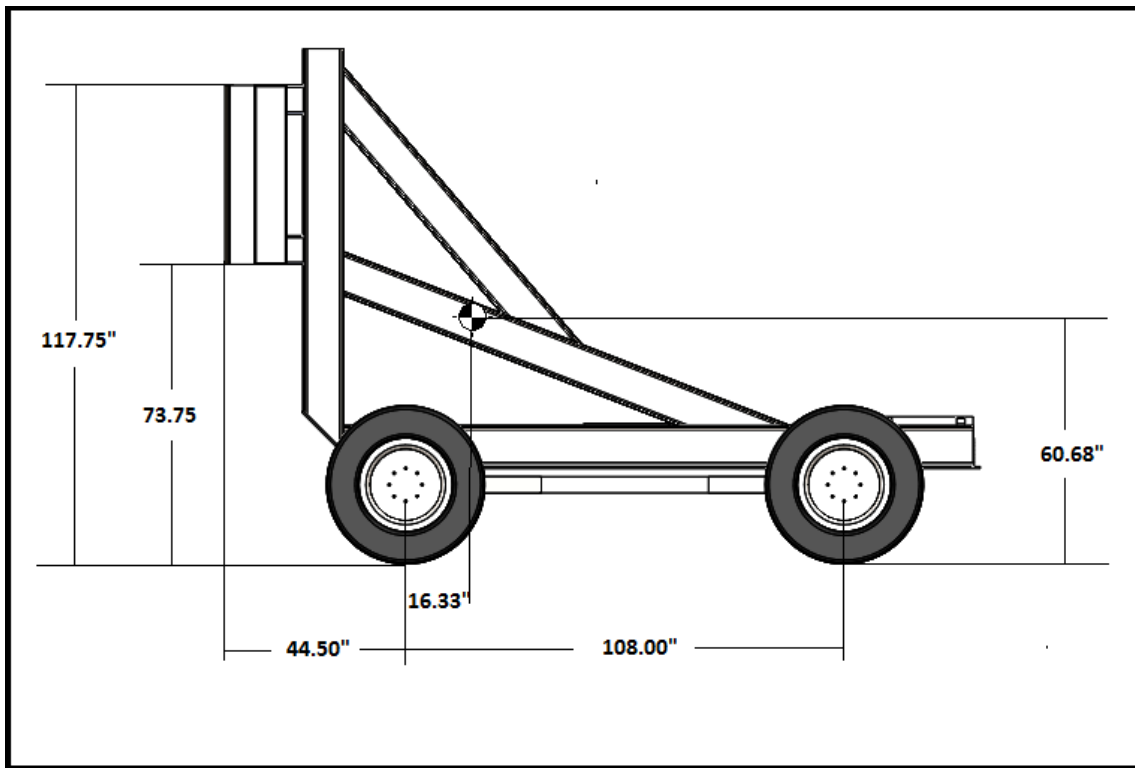

Figure 4 - Side view of dynamic load impact device

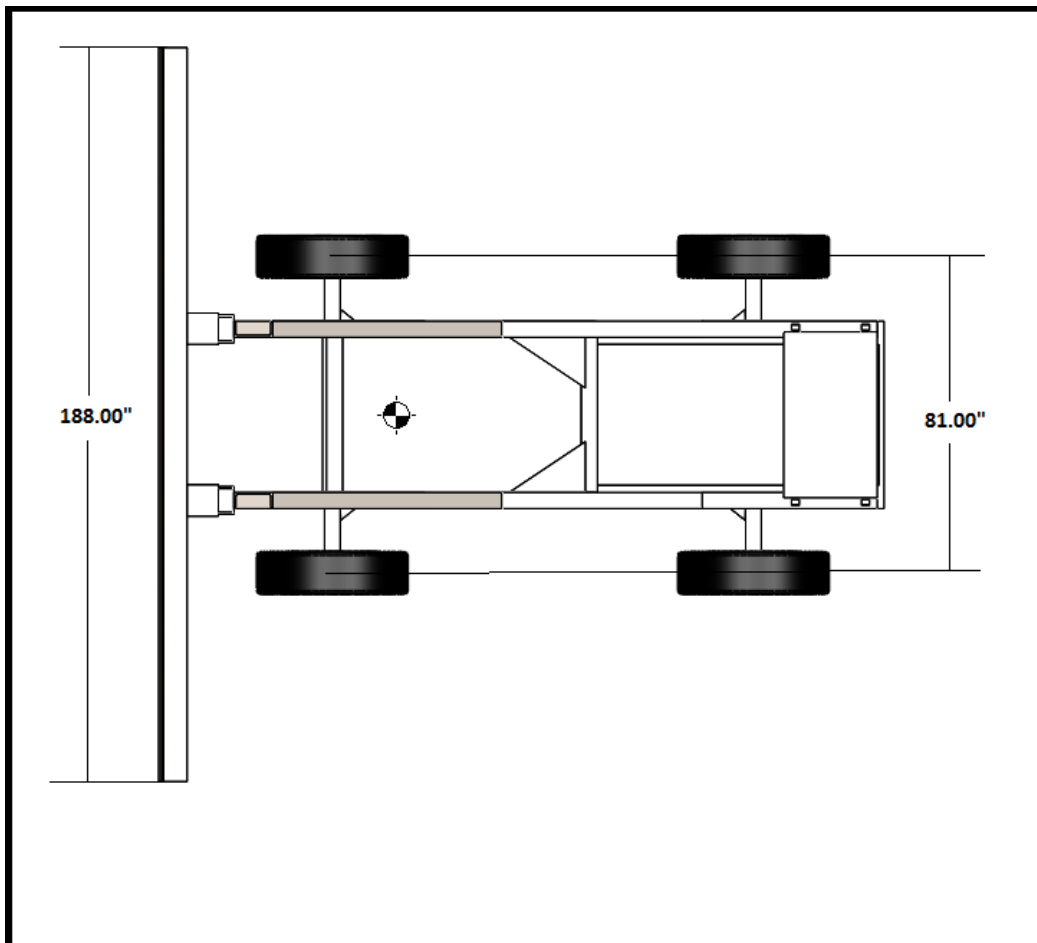

Figure 5 - Top view of dynamic load impact device

For the dynamic pre-load phase of the test, the rigid moving barrier, which includes the dynamic test platen, its carriage, all included structure, all suspension, braking and tire elements, and all instrumentation shall have a total mass of between 2268 kg (5000 pounds) and 6804 kg (15000 pounds). The rigid moving barrier is towed and released to freely roll into the modular body at the target impact velocity shown below. System drag should be considered to achieve the target velocity at impact versus when the rigid moving barrier is released from the tow system. Ballast shall be added as necessary to the rear of the carriage to stabilize it and obtain the target mass. The rigid moving barrier impact velocity to obtain the desired pre-load energy level is computed with the equation shown below.

$$VRMB (SI) = \sqrt{\frac{2 * KE}{M}} \quad VRMB (US) = C * \sqrt{\frac{2 * KE * G}{M}} \quad (Eq. 1)$$

where:

- VRMB = Rigid Moving Barrier Impact Velocity for the Dynamic Pre-Load Test in meters per second (m/s) for SI units or Miles Per Hour (mph) in US customary units
- M = Mass of the rigid moving barrier in Kilograms (kg) for SI or pounds (lbs) for US units
- KE = Kinetic Energy of the rigid moving barrier at the Instant of Impact in Joules (J) for SI or Foot-Pounds Force (ft-lbf) for US units
- C = Conversion Factor to Convert from Feet Per Second to Miles Per Hour, 1/1.4667 (mph/ft/s). Only needed for the US customary calculation
- G = Gravitational Constant, 32.174 (lb-ft/s²/lbf). Only needed for the US customary calculation

The rigid moving barrier velocity at impact, based on the minimum 2268 kg (5000 pounds) and maximum 6804 kg (15000 pounds) allowable weight of the rigid moving barrier, will be a maximum of 5.79 m/s (12.94 mph) and minimum of 3.34 m/s (7.47 mph).

5.8 Instrumentation and Observations

- 5.8.1 Follow SAE J211-1 for all electronic instrumentation data acquisition, including front-end sensors. All video shall be captured and processed according to the most recent version of SAE J211-2.
- 5.8.2 Follow SAE J1727 for all post-processing calculations.
- 5.8.3 Record the applied dynamic test platen load with load cells installed between the dynamic test platen and its carriage. Triaxial load cells are recommended.
- 5.8.4 It is recommended that the acceleration of the dynamic test platen be recorded as this data is necessary to calculate the energy transferred to the modular body at impact. If used, accelerometers should be located on the platen adjacent to each load cell.
- 5.8.5 Record the acceleration of the rigid moving barrier using a triaxial accelerometer on the aft side of the dynamic test platen, and also near the cg of the Rigid Moving Barrier.
- 5.8.6 Record the impact velocity using a high-speed optical sensing system and a high-speed timing device.

5.9 Post-Test Inspection and Performance Requirements for the Dynamic Preload Test

- 5.9.1 Validate the kinetic energy of the Rigid Moving Barrier met or exceeded the minimum acceptable value of 37965 Joules (28000 ft-lbf).
- 5.9.2 Verify that all Modular Body entry doors can be opened individually.

- 5.9.3 Inspect the dynamic test platen face to ensure that no permanent deformation is found. Damage to the 19 mm (0.75 inch) plywood face is acceptable.
- 5.9.4 Inspect the test fixture to ensure the base remained at the test angle of $20^\circ \pm 1^\circ$.
- 5.9.4.1 The modular body must remain attached to the simulated frame rails through at least two body mounts, with at least one body mount attached on each simulated frame rail.

6. QUASI-STATIC TEST PROCEDURES

Following successful completion of the testing described in Section 5, the Type I, Type I-AD, Type III, or Type III-AD modular body that was subjected to the dynamic pre-load test shall be utilized in the quasi-static roof crush test. The modular body shall withstand a force equal to 2.5 times the curb weight of the vehicle applied to the roof in the process described below.

- 6.1 The force shall be quasi-statically applied by a rigid quasi-static platen.
- 6.2 The quasi-static platen shall be sufficiently large and positioned such that the module will only be in contact with the interior of the quasi-static platen, not the outer edge. In other words, the length, width, and surface area of the quasi-static platen shall exceed the surface of the roof line to which the loading will be applied. The quasi-static platen shall have a degree of freedom in the lateral direction as to not resist the modular body's tendency to rack during the load test. Figure 6 shows a typical test setup for the quasi-static roof crush test.

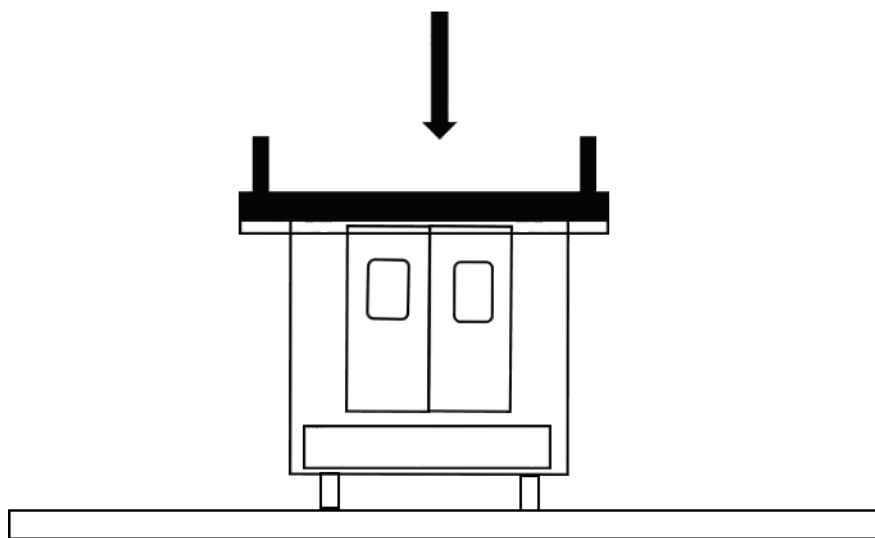

Figure 6 - Typical roof load test setup

- 6.3 All non-structural components that extend above the roof line shall be removed.
- 6.4 Mark the four locations of vertical displacement recording devices in accordance with Figure 2.
- 6.5 Install vertical displacement recording equipment in marked locations.
- 6.6 All entry doors are to be closed and latched but not locked.
- 6.7 Instrumentation
- 6.7.1 All video shall be captured and processed according to the most recent version of SAE J211-2.

- 6.7.2 Acquire instrumentation data at a sample rate no less than 10 samples per second.
- 6.7.3 Record the applied load from the quasi-static platen to the roof of the modular body, with load cells or other devices.
- 6.8 Roof Quasi-Static Test Sequence
- 6.8.1 Position the modular body with the roof that was dynamically preloaded facing the quasi-static platen.
- 6.8.2 The quasi-static platen shall be positioned parallel to the X-Y plane of the chassis. The quasi-static platen moves parallel to the vertical or Z axis of the chassis as illustrated in Figure 1.
- 6.8.3 Lower the quasi-static platen until contact is made with the modular body. Continue loading until a total load of 500 pounds is achieved. Document the vertical displacement at the four vertical displacement reference points. This is the vertical displacement reference position.
- 6.8.4 Loading is increased at an average rate of no less than 150 lb/s and no greater than 1000 lb/s.
- 6.8.5 Increase the load until 100% of the quasi-static test load is achieved.
- 6.8.6 Document the ceiling vertical displacement at the four defined positions.
- 6.8.7 After maintaining at least 100% of the quasi-static test load for a minimum of 10 seconds, the test loads shall be reduced to the curb weight test load
- 6.8.8 Ensure the test load is controlled such that personnel may safely enter the test area. A mechanical stop is recommended to limit movement of the platen beyond a safe zone.
- 6.8.9 Open each modular body entry door individually.
- 6.8.10 Remove the load from the modular body.
7. ACCEPTANCE CRITERIA
- 7.1 The modular body must remain attached to the simulated frame rails through at least two body mounts, with at least one body mount attached on each simulated frame rail, through both phases of testing (dynamic and quasi-static roof crush).
- 7.2 The rigid test floor fixture used in the dynamic test remained at $20^\circ \pm 1^\circ$ post-test.
- 7.3 All doors remained latched and closed during each phase of testing (dynamic, quasi-static roof crush).
- 7.4 The dynamic test platen attached to the Rigid Moving Barrier did not permanently deform by more than 6 mm (0.25 inch) during the Dynamic Pre-Load Test (damage to the plywood face is considered acceptable).
- 7.5 The rigid moving barrier and dynamic test platen shall not impact the test fixture to which the modular body is affixed.
- 7.6 The actual quasi-static test load shall be at least 2.5 times the vehicle curb weight.
- 7.7 Verify that the maximum measured vertical displacement at any one or more of the four indicated reference points in the modular body did not exceed 130 mm (5.125 inches) during the quasi-static test.
- 7.8 Verify that all entry doors were able to be opened as per 5.8.5.2 and 6.8.9.

8. NOTES

8.1 Revision Indicator

A change bar (I) located in the left margin is for the convenience of the user in locating areas where technical revisions, not editorial changes, have been made to the previous issue of this document. An (R) symbol to the left of the document title indicates a complete revision of the document, including technical revisions. Change bars and (R) are not used in original publications, nor in documents that contain editorial changes only.

PREPARED BY THE SAE TRUCK CRASHWORTHINESS COMMITTEE OF
THE TRUCK AND BUS BODY AND OCCUPANT ENVIRONMENT STEERING COMMITTEE