

**NIOSH**

U. S. DEPARTMENT OF HEALTH, EDUCATION, AND WELFARE  
Public Health Service  
Center for Disease Control  
National Institute for Occupational Safety and Health

the  
**RECIRCULATION**  
of **INDUSTRIAL**  
**EXHAUST AIR**

...SYMPOSIUM PROCEEDINGS



THE RECIRCULATION OF INDUSTRIAL EXHAUST AIR

*Proceedings of a Symposium sponsored by the  
National Institute for Occupational Safety  
and Health at Cincinnati, Ohio 45226, October 1977.*

*Contract No. 210-77-0056*

U.S. DEPARTMENT OF HEALTH, EDUCATION, AND WELFARE  
Public Health Service  
Center for Disease Control  
National Institute for Occupational Safety and Health  
Division of Physical Sciences and Engineering  
Cincinnati, Ohio 45226

April 1978

## **DISCLAIMER**

The contents of this report are reproduced herein as received from the contractor.

The opinions, findings, and conclusions expressed herein are not necessarily those of the National Institute for Occupational Safety and Health, nor does mention of company names or products constitute endorsement by the National Institute for Occupational Safety and Health.

NIOSH Project Officer: Alfred A. Amendola  
Principal Investigator: Franklin A. Ayer

**DHEW (NIOSH) Publication No. 78-141**

## PREFACE

These proceedings of the symposium on "The Recirculation of Industrial Exhaust Air" are submitted under Contract No. 210-77-0056 to the National Institute for Occupational Safety and Health of the U.S. Department of Health, Education, and Welfare. The symposium was held in Cincinnati, Ohio, on 6-7 October 1977.

The objective of this symposium was to discuss the development of technical criteria for the recirculation of industrial exhaust air. With emphasis on the protection of the worker's health, technical subject matter discussed included: (1) decision logic for determining recirculation feasibility; (2) design and performance guidelines for recirculation systems; (3) availability of air cleaning and monitoring systems; and (4) maintenance guidelines.

Mr. Robert T. Hughes, Chemical Agents Control Section, Control Technology Research Branch, Division of Physical Sciences and Engineering, National Institute for Occupational Safety and Health, Cincinnati, Ohio, was the Symposium General Chairman.

Mr. Alfred A. Amendola, Control Technology Research Branch, Division of Physical Sciences and Engineering, National Institute for Occupational Safety and Health, Cincinnati, Ohio, was the Symposium Vice-Chairman and Project Officer.

Mr. Franklin A. Ayer, Manager, Technology and Resource Management Department, Center for Technology Applications, Research Triangle Institute, Research Triangle Park, North Carolina, was the Symposium Coordinator and Compiler of the proceedings.

## ABSTRACT

The recirculation of industrial exhaust air is a means for reducing industrial energy requirements.

NIOSH sponsored a study by Arthur D. Little, Inc., to develop guidelines to help insure that the design, installation, and operation of recirculating systems will assure the health and safety of employees within the workplace. The purpose of this symposium was to review that study and to discuss recirculation in general, with special attention given to the needs of industry and the system designer.

Topics covered included the logic and procedures to evaluate the assumption, with certain restrictions, that all chemicals are potentially suitable for a given recirculation/process situation; the needs of industry and the system designer; contaminant monitoring; and recirculation practices and research in Sweden.

It was concluded that recirculation is feasible to conserve energy provided that certain specific precautions are taken to protect the health of the worker. In addition it was recommended that additional technical information should be obtained that would concentrate on real-life experiences in attempting to validate the guidelines that have been developed and would include results of studies that industry has undertaken on its own.

This report was submitted by the Research Triangle Institute, Research Triangle Park, North Carolina, in fulfillment of Contract No. 210-77-0056.

## CONTENTS

	Page
<b>Preface</b> .....	iii
<b>Abstract</b> .....	iv
<b>6 October 1977</b>	
<b>Welcome</b> .....	1
Walter M. Haag	
<b>Introductory Remarks</b> .....	3
Robert T. Hughes, Seminar Chairman	
<b>Development of a Recommended Approach for Recirculation of Industrial Exhaust Air</b> .....	7
P. R. Nayak, Ph.D	
R. S. Stricoff (Speaker)	
J. H. Hagopian (Speaker)	
<b>Technical Critique of Recirculation of Industrial Exhaust Air Criteria</b> .....	27
William L. Dyson, Ph.D.	
<b>A Regulatory Perspective on the Recirculation of Industrial Exhaust Air</b> .....	37
James Lim	
<b>Panel Discussion: Overall Assessment of Criteria Development</b> .....	41
Robert T. Hughes	
John H. Hagopian	
R. Scott Stricoff	
William L. Dyson, Ph.D.	
James C. Barrett	
James Lim	
<b>Industrial Energy Management</b> .....	55
Richard H. Stephens, Ph.D. (Speaker)	
Herbert M. Kosstrin, Ph.D.	
Dimitri E. Pavlakis	
<b>Utilization of Air Cleaning Equipment in Exhaust Air Recirculation Systems</b> .....	71
John T. Talty	

## CONTENTS (con.)

	Page
Monitoring of Particulates in Recirculated Air . . . . .	89
Steven H. Chansky	
<b>7 October 1977</b>	
Validation of Design Criteria for Recirculation of Industrial Exhaust Air Systems . . . . .	105
Lawrence F. Bullock	
Air Recirculation From Foundry Operations . . . . .	117
Robert W. Potokar	
A Consultant's View on Air Recirculation . . . . .	123
George M. Hama	
Air Recirculation Practices and Research in Sweden . . . . .	129
Lars Olander	
Recapitulation . . . . .	139
Peter W. Kalika	
Closing Remarks . . . . .	145
Robert T. Hughes	
Appendix. List of Speakers and Attendees . . . . .	147

## WELCOME

Walter M. Haag\*

I would like to take this opportunity on behalf of the National Institute for Occupational Safety and Health and its Director, Dr. John Finklea, to welcome you here today in this important endeavor. I think it comes at a time when energy is foremost on all of America's minds.

Before I take a few moments and acquaint you with the work that NIOSH has done in the area of Exhaust Air Recirculation, I would like to draw your attention to the fact that this past year the Institute and the Division of Physical Sciences and Engineering, in particular, have embarked on a new effort that we refer to as simply control technology assessment. This effort is largely directed to the positive aspects of identifying where good engineering controls and other protective measures are in the workplace in both the private and public sectors, and in trying to encourage the exchange of that information among the various professionals and other groups that are interested in occupational safety and health.

This past year we have had four major contracts associated with assessing the use of good engineering controls, monitoring, work practices, and in the use of personal protective equipment. We are just in the process of completing one of those efforts in the plastics and resin industry. We hope to have that final report available within the next month or two, so the findings of that study will be generally available. I encourage you to review that material and be aware of this important endeavor. We also have contractual efforts underway in the foundries industry, the Textile Finishing Industry, and the Secondary Smelters Industries.

This year, we have a number of other studies planned, and I think you will find that the assessments and the work that is being done, are in areas that are of interest to you as engineers and other professionals.

I would like to take a few moments to acquaint you with the work that NIOSH has undertaken in the area of exhaust air recirculation.

When it first became apparent that the cost of energy was increasing and would continue to increase, and that the availability of energy at any cost was questionable, the stage was set for energy conservation. One method of conservation is the reuse of air that has already been tempered. This recirculation of air, while returning useful energy to the workplace, also returns unwanted contaminants.

---

\*Director, Division of Physical Sciences and Engineering, NIOSH, Cincinnati, Ohio.

NIOSH, recognizing that there would be a need for guidelines, which, when followed, would enable industry to recirculate exhaust air while maintaining a safe and healthful workplace, began its program to develop those guidelines. The program began with a contract effort by Southwest Research Institute in 1974-75. This was followed by a symposium held in October 1975, which served to present the contract results and as a place to discuss the topic of recirculation. The next step was to take the knowledge already gained and add to it in order to develop guidelines. We entered into another contract, this time with Arthur D. Little, Inc. We meet here today and tomorrow in order to learn what knowledge the latest contract has produced and share what we have learned since the last symposium.

Our next step will be to validate the proposed guidelines in industrial applications and do some limited research through a pilot study into various components of recirculation systems.

The ultimate goal is to develop useful guidelines for the design and operation of recirculation systems. I am sure that the presentations and discussions of this symposium will help further that goal.

## INTRODUCTORY REMARKS

Robert T. Hughes\*

We probably all have heard many a naturalist, describing the seriousness of the energy situation in the world today. I recently ran across a description of the situation that is very interesting, and I would like to pass it on to you.

Science tells us that life has existed on the planet Earth for approximately 1 billion years. If we could compress that 1 billion years into a single calendar year so that on January 1st life appeared as some kind of protozoa in some kind of tropical sea, the following December 31st, at 12:00 midnight, would be today.

It is interesting to see when some important events happened in our compressed year, and for our purposes today we can start in early July, because that is when the first oil and gas deposits began to be formed. Two months later, in early September, coal began to be laid down. In October, the first chicken-sized lizards--predecessors of the dinosaurs--began to be found. On Halloween, the first mammals appeared. By the second week in December, the dinosaurs had evolved into gargantuan reptiles, some of them 2 or 3 stories tall. Their nervous systems were primitive and unable to cope with their changing environment, so the dinosaurs fell into extinction. On December 26, the Colorado River began its 10-million-year task of creating the Grand Canyon by erosion.

Finally, on December 31, the last day of our year at 5 o'clock in the morning, the first creature with a spark of creative intelligence began to walk erect. It was man! Two hours later the earth falls into the grasp of the Ice Age, and there it remains until 11:15 p.m. Just think--we're only 45 minutes from the end of our geologic year, and we are just emerging from the Ice Age!

Our oldest recorded history is about 5,000 years old. That's about the same time the wheel was invented, and the oldest living things on the planet--the giant sequoias--were born. On our geologic time scale, the time is 3 minutes before midnight. Columbus discovered the new world at 18 seconds before midnight. The industrial revolution began at 8 seconds before midnight--using for energy the wind, flowing water, and wood--all things that nature replenished as they were used. Then, at 4 seconds before midnight a man named Edwin Drake made an important discovery in Pennsylvania--he discovered oil and the industrial revolution took on a new look.

---

\*Control Technology Research Branch, National Institute for Occupational Safety and Health, Cincinnati, Ohio.

Counting down to the present--3 seconds, 2 seconds, 1 second, midnight--we find ourselves in the full heat of the Age of Fossil Fuels. We now receive about 94 percent of all of the energy we use from coal, oil, and natural gas, and only about 6 percent from other sources, chiefly water power and nuclear power.

A child who is born today will use in his lifetime, at today's rates of consumption, 175 tons of coal, 2,000 barrels of oil, and 7-1/2 million cubic feet of natural gas.

Looking into the future, we can predict that our natural gas may run out at about 1 second after midnight; that our remaining supplies of oil may become economically irretrievable at about 4 seconds after midnight; and that our coal will last only until 18 seconds after midnight. We must face the inescapable conclusion that when the history of this planet Earth is finally written, the chapter called the Age of the Fossil Fuels will be so very short that it will represent only a few seconds of our geologic year.

It is mandatory that we seek and use all of the energy conservation procedures and methods available to us. Recirculation of exhaust air is one such item. It probably, in the overall scope of the energy usage, is just a second in the geological year just mentioned. But it must be considered.

For a recirculation system to be an acceptable method of energy conservation, suitable criteria must be available for system design, performance, and operation that will assure worker protection from harmful toxic contaminants. Recirculation has been employed infrequently in the past with the result being that criteria have not been developed that will successfully permit a consistent and safe approach to the design and operation of the recirculation systems. We have an urgent need for such criteria as industry is turning in ever-increasing numbers to recirculation. Improper system installation, design, or operation could result in severe exposure to toxic contaminants.

A NIOSH-sponsored study with the Southwest Research Institute in 1974-75 provided a baseline for recirculation criteria. Perhaps the most important finding of this initial study was that it was not possible to develop a hard-and-fast list of toxic chemical agents which may or may not be recirculated, and that each process situation must be evaluated on its own merit regarding recirculation. For example, exhaust air containing a highly toxic chemical may be recirculated with little or no problem if the total amount of the chemical were small compared to the overall airflow within the workplace. Conversely, a moderately toxic chemical may not be at all suitable if the total quantity was high with regard to the overall workplace airflows. Using the baseline obtained with the 1974 study, a second study with Arthur D. Little has been completed that assumes, with certain restrictions, that all chemical agents are potentially suitable for recirculation. This study provides the logic and procedures to both objectively and quantitatively evaluate this potential for a given recirculation/process situation and provides assistance to the designer in designing the system.

The objective of the symposium is to review the results of the second study and to discuss recirculation in general, with special attention given to the needs of industry and the system designer. It is the system designer and

industrial user who need the final criteria so that recirculation can be put into operation in a manner that will assure a healthful working environment.

At this point, I would like to clarify three points which have caused some previous concern:

1. the work discussed here is neither to encourage nor discourage recirculation, but, as just mentioned, to provide assistance to those who choose this method of energy conservation;
2. recirculation is only one of several methods of conserving energy in the industrial workplace; and
3. the criteria and guidelines resulting from this study are not intended in any manner to be regulatory in nature.



## DEVELOPMENT OF A RECOMMENDED APPROACH FOR RECIRCULATION OF INDUSTRIAL EXHAUST AIR

P. R. Nayak, Ph.D.,  
R. S. Stricoff, and  
J. H. Hagopian\*

### Abstract

*Recirculating exhaust systems can provide for substantial reductions in consumption of energy for conditioning makeup air, while maintaining a healthful and comfortable working environment. In some instances, it may be possible to reduce the level of toxic materials in the workplace while conserving energy. Therefore, given the reduced availability of energy sources at any price, significant savings may accrue from the use of recirculating exhaust systems in those situations where large volumes of makeup air must be conditioned to maintain worker comfort and process control.*

*However, industrial exhausts often contain toxic contaminants, frequently of unknown type and at unknown concentration levels. When these exhausts are emitted into the outside atmosphere, the health impacts on employees within the plants are generally small. Recirculation implies cleaning such exhausts and delivering them back into the plant. Such a procedure may lead to adverse health impacts in any of the following situations:*

- 1. the planned level of cleaning is inadequate;*
- 2. contaminants exist in the exhaust which are not cleaned because their existence is not known;*
- 3. the air cleaner fails to perform its function, resulting in the delivery of inadequately cleaned or uncleaned exhaust air into the plant; or*
- 4. contaminants (such as carcinogens) exist in the exhaust for which the preferred policy is to eliminate their presence in the employees' breathing environment as completely as possible.*

*It is the intent of this paper to present an outline of information which will help insure that such situations do not arise in practice.*

### INTRODUCTION

The recirculation of industrial exhaust air provides an engineering approach toward energy conservation that has a potentially wide application throughout

---

\*All at Arthur D. Little, Inc., Cambridge, Massachusetts.

industry. Because of the novelty of recirculating systems and the consequent lack of accumulated experience, however, the possibility exists of hazardous exposure of personnel to toxic materials in the recirculated exhaust. NIOSH has therefore sponsored two analytical studies of the safety aspects of industrial exhaust recirculation, the second of which was conducted at Arthur D. Little, Inc. This paper summarizes the approach adopted in the ADL study. For further detail, the reader is referred to the final report based on the ADL study, to be published by NIOSH in the near future.

This study represents an initial effort to develop a practical approach for exhaust air recirculation. It is recognized that, as recirculating exhaust installations become more common and as this approach is applied, modification and refinement may be appropriate. One effort for validation is planned by NIOSH during 1977-78, and the results of NIOSH-sponsored field validation efforts will provide important input to the revision of this report. As various industrial facilities evaluate and implement exhaust air recirculation, it is hoped that their experiences will be shared in the technical literature.

## GOALS AND LIMITATIONS

The goal of this study was to provide guidelines to help insure that the design, installation, and operation of recirculating systems is undertaken and completed in a manner which will assure the health and safety of employees within the workplace.

The study did not take a stand on the pros and cons of recirculating exhaust systems, except in those instances in which they were clearly considered demonstrably unsafe. Instead, the study concentrated on developing general system specifications and design procedures which, if adhered to, will insure that no adverse impacts on employees' health are experienced. However, the procedures provided are such that the economic advantages of recirculating systems can be estimated and maximized.

Further, this study did not attempt to guide the detailed design of or the specification of hardware for a recirculating ventilation system. Rather, a general procedure was developed for assessing the applicability of recirculation and developing general system specifications to assure that recirculation is undertaken safely.

## GENERAL PHILOSOPHY

The overall philosophy applied in ADL's study may be summarized succinctly as follows:

1. The overall goal of safety analyses of recirculating industrial exhaust systems is to insure that no person is exposed to hazardous concentrations of any chemical in the exhaust.
2. Regardless of the reliability designed into a recirculating system, it may eventually fail. The consequences of a failure must be adequately mitigated.

3. Because of the complexity and relative novelty of recirculating industrial exhaust systems, a multifaceted approach must be utilized in their design and installation. Facets are: extrapolation from past experience; in-plant surveys of airflow rates, contaminant concentration levels and transients; analytical studies; and post-installation testing.

## ISSUES OF CONCERN

The main criterion guiding the ADL study was safety. This criterion required identification and consideration of numerous factors which influence the safe design and operation of a recirculating system. Overall, these factors could be categorized under the headings of safety, economics, technical feasibility, and engineering feasibility.

### Safety

Inadequate safety in a recirculating exhaust system may result from one or more of the following causes:

1. The planned level of cleaning is inadequate.
2. Contaminants exist in the recirculated exhaust that are not cleaned because their existence goes unnoticed.
3. System failures occur.
4. Contaminants (such as human carcinogens) exist in the exhaust for which the preferred policy is to eliminate their presence in the employee's breathing environment as far as possible.
5. Contaminants exist for which the safe limits are nowhere clearly spelled out.
6. System components fail to meet design specifications.
7. Recirculation of an exhaust results in reduced dilution ventilation in neighboring areas.

### Economics

Economic factors that will need to be taken into account in assessing a recirculating exhaust system are:

1. the availability and cost of energy;
2. the cost of design studies for a recirculating system;
3. the capital cost of air cleaners, monitors, alarms, bypasses, and ductwork; and
4. operating costs (maintenance, parts, power, personnel, training, etc.).

### Technical Feasibility

Whether or not a system is technically feasible will depend principally on:

1. whether an air cleaner is available with the desired efficiency for each of the contaminants requiring cleaning; and
2. whether a technique is available for detecting reduced performance of the system.

## Engineering Feasibility

An engineering feasibility assessment must address several issues including the following:

1. estimation of the input parameters required by the analytical models used in system design;
2. availability of space for installing the air cleaner;
3. feasibility of routing ductwork as required; and
4. ability to maintain the system, including the monitor, to adequate levels of performance.

## AIR CLEANERS

The important characteristics of air cleaners that must be taken into account in selecting one or more for a recirculating exhaust system are:

1. the fractional efficiency;
2. the ratings available, defined as the volume of air each unit is capable of cleaning;
3. space requirements;
4. specificity of cleaning ability: whether the cleaner is specific to a contaminant or a group of contaminants; groups might be: particulates, organic vapors, etc.;
5. failure modes: the ways in which cleaner performance can degenerate;
6. ease of detection of failure modes;
7. reliability, or the frequency of failure;
8. ease of maintenance;
9. pressure drop, and its variation with the extent of loading;
10. method of disposal of the collected contaminant, and its possible impact on plant personnel;
11. modifications to airstream characteristics such as humidity, temperature, and ozone content, as well as the possible chemical transformation of contaminants due to reaction or decomposition; and
12. cost, both capital and operating.

It is recommended that these factors be carefully reviewed with expert help before an air cleaner is selected. Factors relating to failure modes, reliability, ease of maintenance, and airstream modification are of particular importance to the development of a safe recirculating system.

## Cleaner Combinations

Apart from the variety of air cleaner characteristics listed above, the designer must also deal with the possibility of combining one or more air cleaners, of the same type or of different types, in series or in parallel. The pros and cons of the various possible combinations are the subject of continuing debate, and it is not believed that general recommendations are possible. The following observations may, however, be useful.

1. When several similar exhausts are to be cleaned, significant safety benefits can be obtained by cleaning them in parallel, and then

mixing the cleaned exhausts before reintroduction into the work space.

2. When particulate and gaseous contaminants coexist in an exhaust, series of cleaners of different types are almost inevitable. An important issue is which phase should be cleaned first, since the first cleaner in the series will see both phases. This may or may not impair its performance.
3. Redundant identical cleaners in series help improve safety but make little economic sense. More useful (with particulates) is prefiltering to increase the life of the main filter, and the use of an absolute filter after the main filter. The absolute filter can act both as a safeguard and as a monitoring device.

## CONTAMINANT CHARACTERIZATION

The types and quantities of contaminants released from a particular process have a major influence on the feasibility of recirculating the process exhaust. The contaminants' characteristics will help to determine whether recirculation is desirable, whether economical cleaning of the exhaust is possible, and whether system monitoring is feasible.

All contaminants in breathing zones and in exhausts to be recirculated must be identified and all concentration levels quantified during the initial stages of recirculation evaluation. No "shortcuts" exist for bypassing this requirement except under a few special circumstances. Thorough knowledge of existing or typical conditions near a process is a prerequisite to determining the impact of recirculation upon the plant area of concern.

Although some contaminants are intuitively more desirable for recirculation than others, the availability of adequate cleaning and monitoring equipment will permit the recirculation of virtually any contaminant. However, it is recommended that substances designated as human carcinogens by OSHA be excluded from recirculation since there are no demonstrated safe exposure levels for carcinogens. Substances suspected of being carcinogenic must be evaluated on a case-by-case basis by qualified health personnel.

## DESIRED OR ALLOWED CONCENTRATION LEVELS

During the design and implementation of recirculation, one must make a conscious decision regarding the concentrations of airborne contaminants that are desirable and/or allowable in breathing zones. There are several sets of established guidelines for the definition of allowable levels of exposure to toxic substances. These include Occupational Safety and Health Administration (OSHA) regulations, NIOSH Criteria Documents, and American Conference of Governmental Industrial Hygienists (ACGIH) Threshold Limit Values (TLVs). While the latter two sources generally reflect more up-to-date judgments on industrial toxicology, the OSHA regulations are mandatory standards.

Where established guidelines for an allowable exposure level do not exist for one or more contaminants at a candidate recirculation site, available toxicological literature should be reviewed by a qualified health professional to select a "pseudo TLV." The absence of established exposure guidelines may

suggest that a contaminant causes no adverse health effects, but is generally likely to mean that the contaminant's presence is not sufficiently widespread to have promoted specific consideration by OSHA, NIOSH, or the ACGIH. It is important to recognize that the employer is responsible for providing a safe and healthful work place, even where specific OSHA regulations do not exist.

One must also be concerned about potential synergistic effects when a mixture of substances is to be recirculated. There are situations in which the simultaneous presence of two contaminants will cause an enhancement (or inhibition) of the anticipated physiological effects of exposure. Such effects follow no recognized pattern, and may be identified only through reviews of previous exposure experience and toxicological results. Such consideration should always be given prior to recirculation of air from processes and worksites where multiple contaminants are present, and this evaluation must also be made by a qualified health professional.

Other factors to be considered in the selection of desired exposure levels include the aesthetic effects and chemical/physical properties of contaminants. Objectionable odors, corrosivity, flammability, and reactivity are appropriate examples.

Finally, one should consider the application of a safety factor to selected exposure levels. Although toxicologically suggested levels can be considered safe, there is no guarantee that these levels will not be exceeded upon implementation of recirculation. The design of any new process or control system entails some degree of uncertainty. Hence, the design of a recirculation system to provide marginally acceptable exposure levels may result in inadequate control upon actual system operation.

#### SURVEILLANCE AND RESPONSE STRATEGIES

If a recirculation system fails, the result may be rapid buildup of contaminant levels in the workplace environment. To prevent such a potentially health-threatening situation from going undetected, it is recommended that all recirculation systems include as an integral component a surveillance subsystem. The function of this subsystem will be to detect system failures and permit a timely response.

In designing a recirculation surveillance system, the approach that one would logically employ would be to consider the exhaust stream contaminants, determine what system(s) are available for surveillance, and select hardware with consideration for cost, reliability, life-span, etc. The types of monitoring approaches that might be considered range from a simple pressure-drop sensor on a particulate filter through nonspecific gas and vapor detectors (like those utilized in smoke detectors) to sophisticated automatic gas chromatograph systems. In addition, consideration might be given to the use of an intermittent, periodic sampling protocol rather than continuous sampling; and sampling of general area air rather than ventilation duct air might be considered.

Of the various approaches to surveillance, no single system is most appropriate in all situations. However, there are some clear-cut mismatches between a monitoring concept and a recirculation application. In order to

assist the recirculation system planner in insuring that his contemplated surveillance system is not inappropriate, several guidelines have been developed describing suggested use conditions for various classes of monitors.

### Automatic Systems

Automatic surveillance is always desirable since it reduces the possibility that human error or neglect may lead to unsafe working conditions. However, automatic monitoring can entail large capital costs, may be prone to mechanical or electrical failure in industrial environments, and will not be available for all contaminants and mixtures of contaminants. Additionally, an automatic monitoring subsystem must satisfy the following operation requirement:

The sum of the time interval between samples and the time needed to implement emergency response activities must be less than the critical response time, i.e., the time interval from system failure to the onset of unacceptable breathing zone concentrations (see fig. 1).

### Manual Systems

Because manual surveillance is prone to failure through human error, this strategy is only recommended where the following conditions are satisfied:

1. the critical response time is greater than 4 hours; and
2. the sum of the time interval between samples and the time needed to implement emergency response activities is less than the critical response time; and
3. the only contaminants present are nuisance (nontoxic) materials; and/or
4. if gases or vapors which are simple asphyxiants are involved, a continuous combustible gas detector (if appropriate) and an oxygen deficiency monitor are employed.

If the above conditions are satisfied and a manual surveillance system is to be utilized, the following minimum procedural steps should be planned:

1. A written monitoring protocol should be prepared and the responsibility for monitoring assigned to a specific employee,
2. All employees should be instructed regarding the impact of recirculation system failure and the planned responses to such failure (which may range from verifying the operation of an automatic bypass damper to plant evacuation).
3. Monitoring results should be recorded in a log, and the log should be regularly checked by plant management and/or safety personnel.

### Area Systems

For an area monitoring system to be appropriate, the following conditions should be satisfied:

1. Contaminant level fluctuations based upon normal process operation should be well characterized quantitatively.

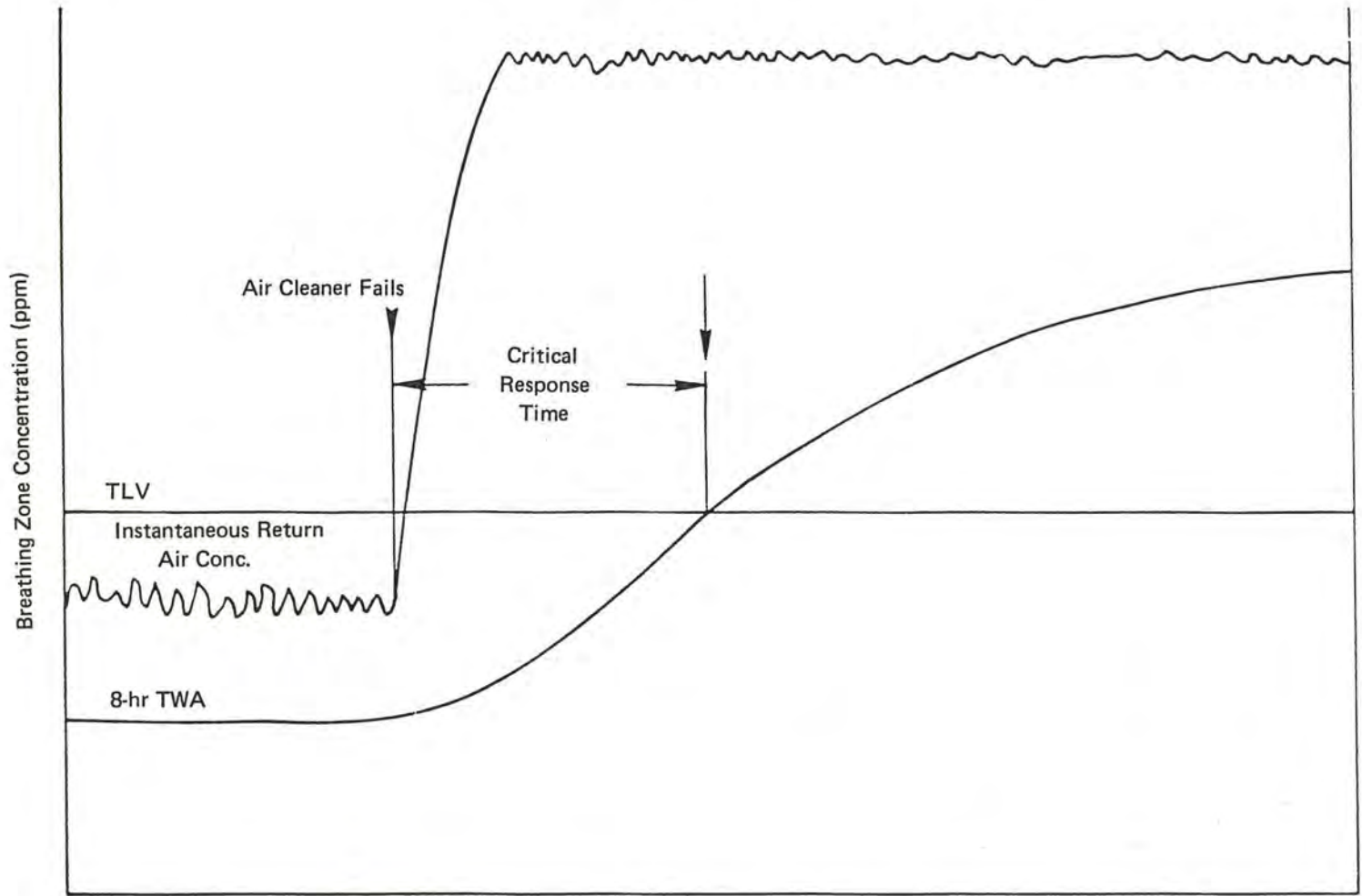

Figure 1. Sample results of transient analysis.

2. Anticipated process-related contaminant level peaks should be below the level (defined in the transient analysis) that is reached at the critical detection time (see fig. 1).
3. The area sensor should include those points that (based upon smoke-tube or tracer-gas airflow studies) are expected to be affected first if the recirculation system fails.
4. The only contaminants present are nuisance (nontoxic) substances.

### Duct Systems

A duct system is recommended when all types of air cleaner failure can be detected, i.e., reduced airflow as well as increased contamination of return air.

### Contaminant-Specific Systems

Contaminant-specific monitoring subsystems may be employed in any installation where:

1. the identities of all contaminants are known;
2. each contaminant whose acceptable level may be exceeded is monitored; and
3. the violation of any contaminant's acceptable level, or the acceptable level of the mixture present, triggers an alarm.

### Nonspecific Systems

The following conditions should be satisfied by any nonspecific monitoring system:

1. The air characteristic measured must be known to change with an increase in the concentration of any contaminant, and combination of contaminants, present.
2. The trigger level selected should be tested to insure that recirculation system failures rapidly trigger an alarm.

### Summary of Surveillance Strategy Selection

Each potential surveillance system, when classified according to its automation, location, and principle of operation, can be placed into one of eight categories. Based upon the guidelines presented, the applicability of each category to any contemplated recirculation system can be judged.

For any contemplated recirculation system, the choice among acceptable surveillance strategies may be made based upon convenience, equipment availability, and cost.

<u>Automation</u>	<u>Location</u>	<u>Principle of Operation</u>	<u>Acceptable</u>	<u>Not Acceptable</u>
Automatic	Duct	Specific	_____	_____
		Nonspecific	_____	_____
	Area	Specific	_____	_____
		Nonspecific	_____	_____
Manual	Duct	Specific	_____	_____
		Nonspecific	_____	_____
	Area	Specific	_____	_____
		Nonspecific	_____	_____

## DESIGN TECHNIQUES

### An Overall Perspective

It is obviously not sufficient for an individual or group interested in recirculation to approach the subject in a completely qualitative fashion. At some point in the process, it becomes necessary to quantify the various parameters which describe feasible systems, to develop firm estimates for system component specifications, and to evaluate the effects of various design options upon contaminant exposures experienced and overall system costs.

One approach to this task involves the close examination of processes conducted by industry and the development of specific system design recommendations on a case-by-case basis. The resulting information might then be presented in a format comparable to that of section 5 of the ACGIH Industrial Ventilation Manual. The design process would thus be simplified and the projected results would be supported with actual industrial experience. Many may argue that this approach is most desirable, and in many respects, they may ultimately be correct. However, the development of the necessary information would entail considerable funds and time.

A second approach requires the development of generalized analytical models capable of representing a wide variety of feasible recirculation systems. If properly formulated, and practical for utilization, such models would allow the evaluation of proposed system designs even where specific industrial experience is lacking. Additionally, they would provide a greater degree of flexibility for designing systems which best serve the needs of a particular facility. A major disadvantage of the approach, however, is that quantification of some specific parameters required by any type of model would necessitate complicated and sometimes difficult characterization of the workplace and the process conducted therein.

In recognition of the advantages and disadvantages of these approaches to recirculation system design, NIOSH has decided that a combination would be most beneficial. Consequently, it not only asked Arthur D. Little, Inc. (ADL), to develop models, but it has commissioned studies to apply the results of our efforts to various specific, common processes. These studies will serve to validate our criteria and models and will provide the specific data necessary to modify our results, where needs are identified. Additionally, they will serve to develop the process-specific type of information necessary to facilitate the implementation of safe recirculation systems in many plants.

The above discussion has been presented to give proper perspective to the scope and nature of the models developed in the ADL study. Although we believe that they are based on sound physical principles, are comprehensive, yield tractable solutions, and incorporate the most important design variables entering into a cost/benefit analysis, we are also of the opinion that they may require substantial improvement before being considered "finalized" in any sense of the word.

### A Typical Model

To satisfy the need for substantial coverage of all commonly used and proposed system configurations for recirculation, a number of related, but distinctly different models were formulated. Each of these, however, is based on the same methodology and assumptions, and is similarly applied. Thus, for example purposes, it is adequate to describe only one.

Figure 2 illustrates a plant area having some amount of natural ventilation and infiltration, a number of makeup air supply units, two or more local exhaust systems, and a general mechanical ventilation system. For completeness, it also shows an inlet stream ( $Q'_{MU}$ ) which represents a volume rate of makeup air not desired to be modified during the implementation of recirculation. All  $Q$ 's on the figure denote volume rates of flow, and are subscripted or superscripted for differentiation.  $C$ 's similarly denote concentrations.

Figure 3 shows the same area as it might appear after recirculation is implemented, although it is to be realized that one or more of the various streams or components may not be desired or appropriate. These can simply be removed from consideration in model equations by the assignment of zero values.

Major features of this particular model include the combination of local and general exhaust air before entrance to a single air cleaning section, non-recirculation of one or more general or local exhaust streams, provision of optional exhaust air bypasses before and after the air cleaning section, and of most significance, the optional premixing of recirculated air with some amount of fresh makeup air before its return to the plant area. Other models address situations where unit collectors are used, separate air cleaning sections are provided for general and local exhaust streams, and where air is bypassed to the outdoors from some point between two air cleaners in series (as might be necessitated by air quality regulations).

Initial model development efforts, in conjunction with the basic objectives specified, led to the conclusion that the most appropriate approach involved

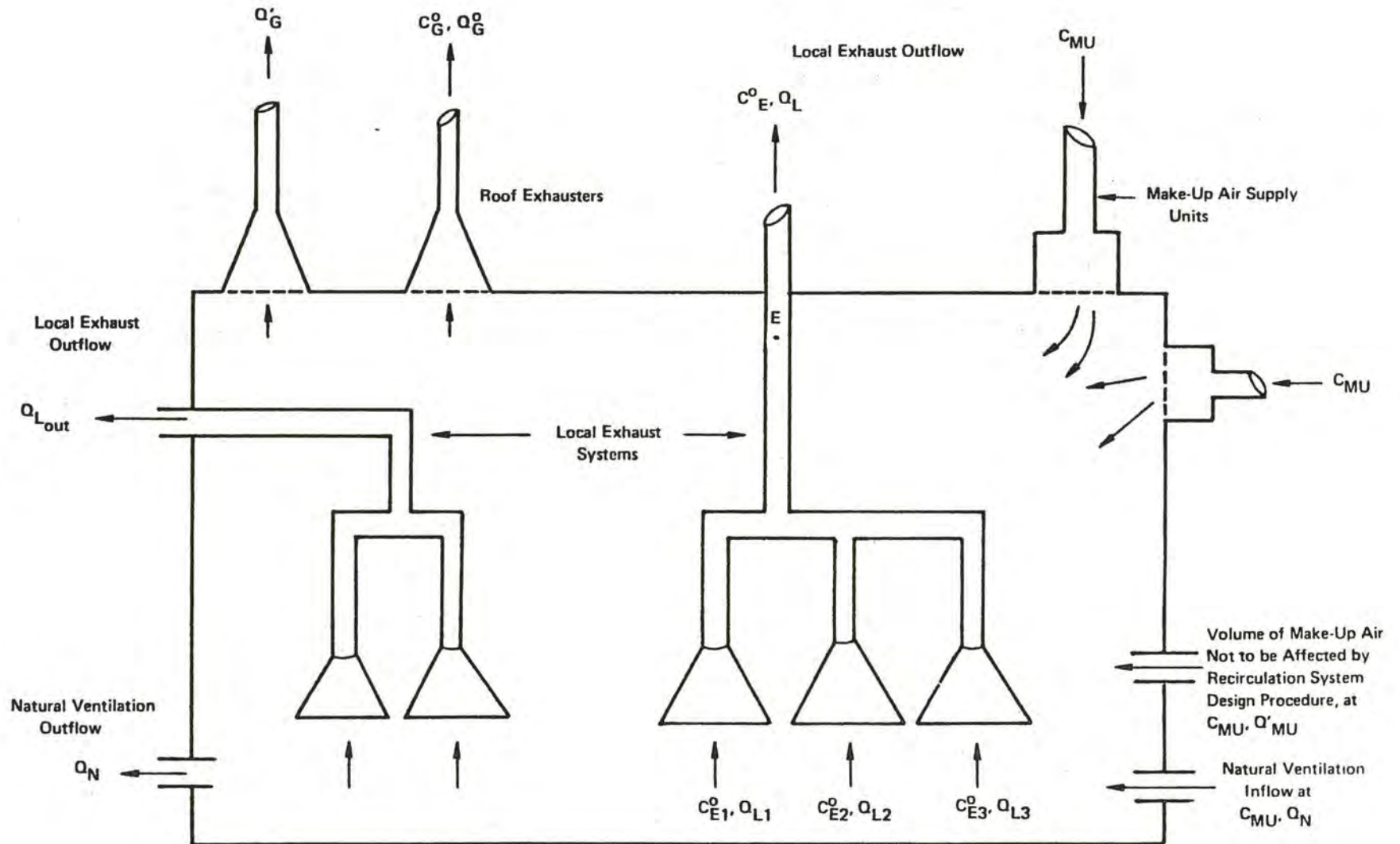
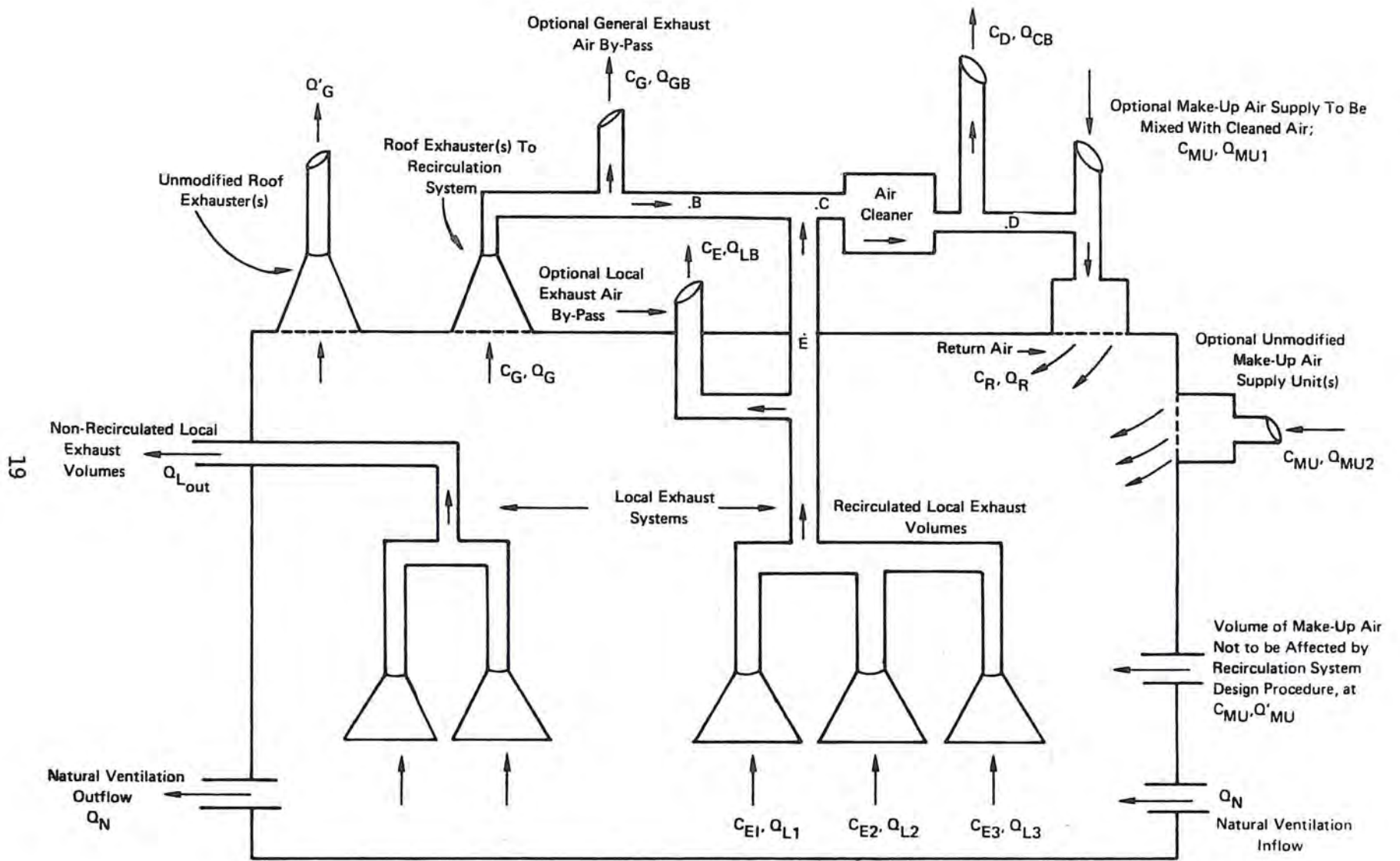

Figure 2. Plant area before recirculation.



19

Figure 3. Plant area with recirculation--Model #1.

the major assumption of steady-state conditions. That is, it was assumed that all concentrations, flow volumes, and air cleaner efficiencies in the system could be represented by constant values for initial system design and optimization purposes. Various arguments that this would lead to overly conservative results, that some plants never achieve steady-state conditions, and others were then accounted for by stipulating that appropriate time-weighted-average parameter values must be measured or estimated for all airstreams entering or leaving the existing or proposed plant area.

Given the steady-state assumption, and a few others, it was then a straightforward procedure to develop equations that allow prediction of the return air contaminant concentration as a function of the original, prerecirculation concentrations in general and local exhaust streams, the associated flow volumes for these streams, an air cleaner efficiency, and other parameters that the user of the model specifies. The equations so developed are presented in exhibit 1. Exhibit 2 defines the flow volume balances that must be satisfied for the equations to be valid.

Definitions for all the symbols used in the expressions, except for one, can be surmised from inspection of the notation on the various exhibits. The final report discusses each parameter at length, in the context of the steady-state assumption. It also provides detailed derivations for these and other equations to demonstrate the methodology used.

The one symbol not defined in exhibit 1 is  $k_p$ . This is a factor, ranging in the closed interval of 0.0 to 1.0, which is called a "contribution factor" of return air to local exhaust systems. By definition, it represents the actual physical fraction of recirculated, locally exhausted air which comes directly from the return airstream. In all but a very few cases, it can be estimated with completely adequate accuracy, by simple inspection of the magnitude of various flow volumes entering and leaving the plant area of interest. The final report discusses how this is accomplished. Of most significance is that final results are quite insensitive to the precise value chosen for  $k_p$ , as long as the return air concentration is much less than the concentration in local exhaust streams.

### The Breathing Zone Equations

Knowledge of contaminant concentrations in return airstreams is insufficient by itself for overall design purposes. Additionally, needed are methods of assessing the effect of the return air upon breathing zone concentrations, and of estimating the cost associated with each feasible system configuration.

The first of these requirements led to the development of two equations we have named "The Breathing Zone Equations." One of these is utilized to relate return air concentrations to breathing zone concentrations for employees not stationed in strong flow fields induced by local exhaust hoods. The other is for employees who may be stationed in such fields. These equations are:

EXHIBIT 1

Typical Model Equations

$$C_D = \frac{(1 - \eta)[U(A+B) + T(D+E)]}{1.0 - (1-\eta)\left(\frac{Q_D}{Q_R}\right)(UF + Tk_R)}$$

$$C_R = \frac{C_D Q_D + C_{MU} Q_{MU1}}{Q_D + Q_{MU1}}$$

where

$$U = \frac{Q_G - Q_{GB}}{Q_G(Q_D + Q_{CB})} \quad \text{if } Q_G = 0, \text{ then } Q_{GB} = 0, \text{ and } U = 0$$

$$A = C_G^o Q_G^o + C_{MU}(Q_{MU2} + Q_{MU}' + k_R Q_L - Q_{MU}^o)$$

$$B = \frac{C_{MU} Q_{MU1} (Q_R - k_R Q_L)}{Q_R} \quad \text{if } Q_R = 0, \text{ then } Q_{MU1} = 0, \text{ and } B = 0$$

$$T = \frac{Q_L - Q_{LB}}{Q_D + Q_{CB}} \quad \text{if } Q_D + Q_{CB} = 0, \text{ then } Q_L \text{ equals } Q_{LB}, \text{ and } T = 0$$

$$D = C_E^o - k_R C_{MU}$$

$$E = \frac{k_R C_{MU} Q_{MU1}}{Q_R} \quad \text{if } Q_R = 0, \text{ then } Q_{MU1} = 0, \text{ and } E = 0$$

$$F = Q_R - k_R Q_L$$

EXHIBIT 2

Flow Volume Balances

$$Q_D = Q_G - Q_{GB} + Q_L - Q_{LB} - Q_{CB}$$

$$Q_{MU1} + Q_{MU2} = Q_{GB} + Q_{LB} + Q_{L_{out}} + Q'_G + Q_{CB} - Q'_{MU}$$

$$Q_R = Q_D + Q_{MU1}$$

$$Q_{MU}^{\circ} = Q_G^{\circ} + Q_L + Q'_G + Q_{L_{out}}$$

$$Q_T^{\circ} = Q_{MU}^{\circ} + Q_N$$

$$Q_T = Q_R + Q_N + Q'_{MU} + Q_{MU2}$$

For employees not in strong flow fields:

$$C_{BZ} = \frac{Q_T^{\circ}}{Q_T} \left( C_{BZG}^{\circ} - C_{MU} \right) + k_{BZ} C_R + \left( 1 - k_{BZ} \right) C_{MU}$$

For employees in strong flow fields:

$$C_{BZ} = C_{BZL}^{\circ} + k_{BZ} \left( C_R - C_{MU} \right)$$

where:

$C_{BZ}$  = TWA breathing zone concentration for some particular employee in the plant;

$Q_T^{\circ}$  = prerecirculation total ventilation rate in the plant;

$Q_T$  = postrecirculation total ventilation rate in the plant;

- $C_{BZG}^o$  = TWA breathing zone concentration in general plant areas not under the direct influence of strong flow fields induced by local exhaust hoods;
- $C_{MU}$  = TWA contaminant concentration, if any, in fresh makeup air;
- $C_{BZL}^o$  = TWA contaminant concentration in plant areas which are under the direct influence of strong flow fields induced by local exhaust hoods;
- $C_R$  = contaminant concentration in return airstreams; and
- $k_{BZ}$  = actual physical fraction of breathing zone air which comes directly from the return airstream.

These equations incorporate a number of novel features and assumptions which provide the key to their understanding. Basic among these are the concepts that:

1. Return air (at concentration  $C_R$ ) will physically replace some known amount of fresh makeup air (at concentration  $C_{MU}$ ) that entered the plant area before recirculation.
2. Increases in the total ventilation rate due to the implementation of recirculation will proportionately lower breathing zone concentrations in general plant areas due to the dilution effect.
3. Some areas in a plant, such as a work station in a large walk-in booth, will not directly experience the dilutory effect of modified total ventilation rates (due to changes in the general mechanical ventilation rate).
4. The physical fraction of breathing zone air which originates in the return airstream, can be measured with a tracer gas technique or conservatively estimated.

A detailed discussion of the rationale underlying each of these concepts, and the manner in which the equations were formulated, is beyond the scope of this paper. Nevertheless, a few words concerning the newly introduced parameter  $k_{BZ}$  are in order.

The parameter  $k_{BZ}$  is a contribution factor similar to the factor  $k_R$  previously discussed. It represents the actual physical fraction of breathing zone air that originates in the return airstream. Introduction of this type of factor was considered to provide certain advantages which the commonly utilized mixing factor,  $k$ , did not. Specifically, these advantages involve the facts that  $k_{BZ}$  can only have a value in the closed interval of zero to one inclusive, that it can be determined or estimated from simple tracer gas studies in many existing plants, and that it may adequately be estimated in many plants from consideration of the volume rates of fresh makeup air and return air entering the plant, and the locations of employees in relation to inlet points.

#### Cost Functions

The last type of relationship that must be defined for system design and optimization purposes is one that relates the cost of the recirculation system

to the volumes of air handled and other parameters of interest. It was beyond the scope of our work to address this question of economics in any great detail, but a simple cost function was formulated and utilized for example purposes throughout our final report.

### Application of a Model

Close inspection of the model equations reveals that some parameters serve to characterize prerecirculation plant conditions, while others must be specified by the user in order for resultant breathing zone concentrations and costs to be assessed. These latter types of data generally include an air cleaner efficiency for the contaminant of interest, and the flow volumes of various bypass and general exhaust streams. Naturally, this leads to the question of what values should be specified for a cost-effective and adequately safe system.

The proper answer to the question requires recognition that any number of recirculation system configurations applied to a plant area may satisfy constraints imposed by health and safety considerations. The major difference among these configurations is simply one of cost. Hence, a user must decide for himself what general types of configurations are appropriate for a particular plant, and must then, by a trial-and-error, repetitive procedure, arrive at the configuration which simultaneously provides adequate safety and acceptable cost savings. The specific approach necessary is fully described, with examples, in the final report for this study.

### Failure Analysis

An important step in the overall design procedure, one which merits individual attention in this paper, is a system failure analysis. The results of this analysis provide necessary data for specification of the monitoring, bypass, and alarm subsystems required for safe operation of each recirculation system configuration addressed. The need for such an analysis is predicated upon the basic assumption that any recirculation system installed may eventually fail, and that the system must be designed to respond to such a failure before hazardous conditions arise. No attempts were made, therefore, to quantify system failure probabilities or rates based on reliability data.

The approach utilized for the failure analysis involves application of model equations, with all parameters optimized, to estimate the postfailure contaminant concentration in the return airstream if the air cleaner completely fails. This concentration, along with a time factor we have called the "rise time" is then utilized to define the "critical response time" within which the monitoring, bypass, and alarm systems must react.

The "rise time" mentioned depends in a complex way upon the location of various breathing zones relative to the return air duct as well as on the nature of the airflow patterns in the plant. It is a quantity that can be measured with relative ease by simulation of failure conditions with a tracer gas release, but which, unfortunately, cannot be estimated with a simple but accurate analytical technique. Given this fact, and the realization that our approach is analogous to the use of common, analytical techniques for transient concentration analysis, it must be noted that this topic requires con-

siderably more attention in future studies. Our approach is state-of-the-art, but that state leaves much to be desired.

A final point is that the analysis only addresses failure modes specific to the components peculiar to recirculation systems. Failures due to duct blockage, power supply interruption, fan motor malfunction, and other similar causes are not addressed. These failure modes and their consequences are not peculiar to recirculating systems. They can occur with equal likelihood in nonrecirculating systems, and it is presumed that adequate measures to deal with them are already in effect.

#### SUMMARY OF GUIDELINES

The following is a concise summary of the major qualitative guidelines developed in the ADL report. Several quantitative guidelines and recommendations also appear in the report. However, these are subject to misinterpretation when taken out of context, and are therefore not included here. The use of these quantitative aids must be based on a careful reading and understanding of the entire report.

The qualitative guidelines are:

1. An initial assessment of the feasibility of recirculation is desirable, if only to insure that all important factors are being taken into consideration in the design phase.
2. No known human carcinogens should be recirculated.
3. All contaminants in the exhaust to be recirculated must be identified, and their concentration levels determined.
4. A qualified health professional should establish permissible levels of these contaminants, based on an examination of the pertinent regulations or, when regulations do not exist, on available toxicological information for the contaminants of concern.
5. All major modes of failure of the recirculating systems that result in health hazards must be identified.
6. A subsystem capable of monitoring system performance, detecting each of the system failure modes, and activating an alarm is an essential requirement.
7. A failure response strategy should be chosen and implemented. Adequate training must be provided to all concerned personnel to insure satisfactory execution of the strategy.
8. The surveillance frequency and response strategy should be based on an analysis of postfailure breathing zone concentration level transients, to insure that adequate time is available for successful implementation of the response strategy.
9. Response trigger levels should be such that no employee is exposed to concentrations violating the TLV, ceiling, or other pertinent limits.
10. Return air should never be directed at an employee, since this leaves no margin of safety in the event of system failure. This is equivalent to requiring a reasonably slow transient breathing zone concentration increase after failure.
11. A performance validation program must be undertaken after installation of the recirculating system. Specific items requiring atten-

tion are: the air cleaner, the monitor, the alarm, and the failure response strategy.

12. A plan for equipment maintenance, periodic monitor calibration, and occasional system testing must be developed, and responsibilities for these assigned. Records should be maintained of these activities. Plant management must lay the greatest emphasis on the proper functioning of the monitoring system, alarm, and failure response strategy.

## TECHNICAL CRITIQUE OF RECIRCULATION OF INDUSTRIAL EXHAUST AIR CRITERIA

William L. Dyson, Ph.D.\*

To critique is to judge that which is worthy of praise as well as to point out limitations. The subject report, "Guidelines for the Recirculation of Industrial Exhaust Air," submitted by Arthur D. Little, Inc., to NIOSH under Contract No. 210-76-0129 (ref. 1), is praiseworthy in many ways. However, when judged from a practical standpoint, it also has several limitations.

The report presents a logical framework for judging the impact on worker safety if exhaust air is recirculated. In this respect, it is certainly an improvement over the report "Development of Criteria for the Recirculation of Exhaust Air" (ref. 2) submitted previously to NIOSH. Few of the considerations for judging the impact of recirculation are original with the subject report. Most have been mentioned previously (ref. 3) or would become self-evident in the planning of a recirculation system. It is, however, the completeness or thoroughness of the present report which is praiseworthy.

The central theme of the subject report is worker safety. This is reasonable since worker safety is a constraint which must be addressed in all recirculation systems. The resulting guidelines are very useful to occupational health personnel for determining the feasibility of recirculation from a health standpoint. The suggestions concerning performance validation, emergency planning, maintenance, and written operating procedures are particularly important reminders that health professionals must be involved at stages beyond feasibility approval. Guidance for the continued assurance of worker safety is the strength of the subject report.

The authors from A. D. Little are careful to point out that the report is not intended as a detailed design manual for recirculation systems. They do, however, occasionally venture away from the central theme of worker safety to present guidelines for selecting equipment or determining the economic feasibility of a recirculation system. These digressions are of limited usefulness to occupational health personnel. Also, because the guidelines in these areas are not fully developed and reference sources are not provided, the report is of limited value to the engineer concerned with design, equipment selection, or economic feasibility. As an example, additional physical and chemical properties that would be important for design and equipment selection, but are not mentioned in chapter 3, are sorbability, electrical or sonic properties,

---

\*Industrial Hygienist, Medical Department, Burlington Industries, Greensboro, North Carolina.

hygroscopicity, agglomerating characteristics, and the potential to poison catalytic converters. A title more representative of the contents of the report might be "Guidelines for Assuring Worker Safety in the Recirculation of Exhaust Air."

In making this commentary on the report I realize that its central purpose was worker safety. It is of value, I think, to point out that this is a limitation of the report itself. When I considered this, one of the questions that came to my mind is, if there were only one copy, where should that copy of the report be located in an industry like ours where there are industrial hygienists and ventilation design engineers. My feeling is that it should very definitely be located in the occupational health professional's office rather than in the design engineer's office. It will be much more useful to him than it will be to the design engineer. It is the type of document that an industrial hygienist might, with some sadistic glee, hand to an engineer who dares to propose recirculation, pointing out all of the health implications to be considered and that are contained in the document, and suggesting to the engineer that he return when he has read the document and understands it. To reiterate, the report is very useful to occupational health personnel in assessing recirculation plans, but it does not provide sufficiently detailed guidance to be helpful to engineers concerned with practical design or economic feasibility. Practical guidance for air cleaner selection is contained in the Air Pollution Manual: Part II from the American Industrial Hygiene Association (ref. 4), and for the economic feasibility of recirculation in a 1951 publication from the New York Department of Labor (ref. 5).

The normal way to approach the modeling of an exhaust recirculation system is through a material balance--input minus removal equals accumulation. Equations depicting the rates of input, removal, and accumulation are integrated between zero and infinite time. The resulting steady-state equations are generally solved for contaminant concentration in the general workroom. Input parameters for those equations that are difficult to measure or must be estimated are the contaminant generation rate, the hood capture efficiency, and the air mixing factor. It is also difficult to relate the general workroom concentration to that which the worker actually breathes.

The authors of the subject report have presented a different mathematical model. As developed in chapter 5 and appendixes A, B, and C, the model is the most unique contribution of the report. The objective of the model is to calculate the contaminant concentration of the recirculated air,  $C_R$ , and then relate this to the worker's breathing zone concentration,  $C_{BZ}$ . The model attempts to address the question of measurability of input parameters, which has been cited as the major shortcoming of previous mathematical models describing recirculation.

It is interesting to note that the abstract of the previous NIOSH symposium on exhaust air recirculation (ref. 6) concluded that "designing of new systems, where possible, is preferable to remodeling or adding on." This is in direct contrast to the present report which states that "generally it is easier to design recirculation systems for retrofitting." This difference of opinion seems partly attributable to the two different mathematical models being considered.

Because it emphasizes the measurability of input parameters, the A. D. Little model is probably more applicable to existing local exhaust systems where the concentration of contaminant in the local exhaust duct,  $C_E$ , can be measured.

Measuring this concentration precludes the need for estimating the contaminant generation rate and hood capture efficiency used in the previous model. If, however, the duct concentration cannot be measured, as in a new system, the A. D. Little model is no better than the previous model in terms of input parameters. In fact, because it requires the estimation of two additional factors,  $k_R$  and  $k_{BZ}$ , as opposed to one, the mixing factor for the previous model, the A. D. Little model may be less desirable for new systems. Clearly, for existing local exhaust systems, the model proposed in the subject report is superior. If for no other reason, this is true because it is more fully developed and integrated into a plan for contaminant monitoring and system failure.

Regardless of the model used, one of the more crucial input parameters is the initial concentration of the contaminant in the breathing zone of the worker,  $C_{BZ}^0$ . Likewise, the ultimate performance validation of the installed system depends upon reliably measuring the worker's exposure to the contaminant (determining  $C_{BZ}$  actual). The guidelines presented in appendix A regarding these parameters are useful. However, reference should be made to recent NIOSH publications on exposure sampling strategy (refs. 7 and 8) as guidelines for improving the reliability of these crucial measurements.

It is stated in the report that for recirculation to be feasible, "the ideal situation would involve an existing ventilation system in which exhaust air is currently being cleaned to comply with EPA regulations." For several reasons, this statement is more correct than the authors may realize. First, EPA regulations limiting the emission of contaminants would provide additional justification for recirculation beyond the energy-saving incentive normally present. Second, our experience at economically removing contaminants from an airstream is greater for chemicals that are regulated by the EPA. Third, automated monitoring systems for specific chemical contaminants are much further developed for those materials now regulated by EPA than for materials that EPA has not addressed.

The report on recirculation submitted by the Southwest Research Institute to NIOSH (ref. 2) addressed the latter two considerations by trying to determine if there are monitors or air cleaners available for specific contaminants. This is important because the availability of contaminant monitoring systems is probably the most serious impediment to "safe" recirculation. Few recirculation systems will be designed that depend upon repeated manual monitoring. If the contaminants are nuisance materials, little monitoring will be done, unless there are complaints. If the contaminants are toxic, then workers, health professionals, and supervisors feel safer with an automatic monitoring system. The guidelines provided by the A. D. Little report are quite reasonable. Perhaps they will stimulate experiments with the recirculation of contaminants for which automatic monitors are not available. Refinement of the concept of a critical response through experimentation is necessary.

Another comment which must be made about the A. D. Little report is one of form rather than content. The authors suggest that ultimately there is no choice but to read and understand the material presented in the appendixes, especially the development of the model. This is a monumental undertaking. The appendixes are equally as long as the main text with far more complexity. The initial system for which the model is developed in appendix A is far too complex to allow gradual development. The reader is immersed in symbols and equations. Only the most dedicated readers will continue through the maze.

It seems that a more desirable approach would have been to start with a simple system such as with one local exhaust, and introduce more complex elements singularly. The value of the report is sufficiently great that it would be a shame to reduce the comprehending audience by unnecessary initial complexity.

#### REFERENCES

1. Arthur D. Little, Inc., "Guidelines for the Recirculation of Industrial Exhaust," Draft Report, Contract 210-76-0129, July 1977.
2. W. J. Astleford, "Development of Criteria for the Recirculation of Exhaust Air," Southwest Research Institute, Final Report Contract CDC-99-74-96, July 1975.
3. American Conference of Governmental Industrial Hygienists, Industrial Ventilation - A Manual of Recommended Practice, 13th ed., 1974.
4. American Industrial Hygiene Association, Air Pollution Manual: Part II - Control Equipment, 66 S. Miller Road, Akron, Ohio, 1968.
5. A. C. Stern, and D. P. O'Neil, "Recirculation from Industrial Exhaust Systems," Monthly Review - New York State Department of Labor, Vol. 30, Nos. 5, 6, and 7, May-July 1951.
6. National Institute for Occupational Safety and Health, "Recirculation of Exhaust Air," proceedings of seminar held October 23-24, 1975, February 1976.
7. N. A. Leidel and K. A. Busch, "Statistical Methods for the Determination of Noncompliance with Occupational Health Standards," National Institute for Occupational Safety and Health, April 1975.
8. N. A. Leidel, K. A. Busch, and J. R. Lynch, "Occupational Exposure Sampling Strategy Manual," National Institute for Occupational Safety and Health, January 1977.

#### DISCUSSION

CHAIRMAN HUGHES: We would like to open the floor for questions at this point, either for Bill Dyson, Scott Stricoff, or John Hagopian.

MR. BILL HALL (Quaker Oats Company, Chicago, Illinois): Are we going to touch on levels of nontoxic dusts that might be permitted in the atmospheres, and are there any known standards by which environmental air may be measured by the plant to determine if the hazard of a dust explosion exists?

MR. STRICOFF: As far as nontoxic or nuisance particulates are concerned, we have, in several places throughout our report, used that case as a specific exception to some of the guidelines that generally apply to the recirculation of toxic materials. Specifically, monitoring requirements where you're dealing with nuisance or nontoxic particulates, and nothing else, are far less critical than monitoring system requirements when one is dealing with toxic materials. As far as the specific levels are concerned, there is, of course, an OSHA standard, as well as a TLV, for uses of nontoxic dusts, and those are legal recommended requirements, airborne levels for worker safety and health.

As far as the explosive dust aspect is concerned, there has been experimental work done to determine the minimum explosive concentrations of different kinds of dust. That research tends not to find its way into the industrial health literature, although it is in fire research literature. There is no method that I'm familiar with for providing an online mechanism for monitoring the explosive concentration of the dust, but the explosive concentration of the dust can be determined from the literature. You can design systems so as to preclude explosive levels and then use a monitoring approach, just looking for changes, assuming that when your system is operating normally you don't have the explosive dust problem.

MR. PHELPS ESHELMAN (General Motors, Warren, Michigan): I have a two-part question for the representatives of Arthur D. Little. In your report that you submitted to us, you talked about air cleaning devices only on systems. Did you take a look at the units that are running in the building with no ductwork attached to them, and why are you penalizing systems which have ductwork, saying that they must be monitored and not the other ones?

The second part of my question is this: Also, in the report you are referring to monitoring of this return air being sent back to the buildings. Do you know of something that will continuously monitor this besides this magic black box you have, and why wasn't more consideration given to area sampling or personal sampling to determine the quality of the air that is being recirculated?

MR. STRICOFF: To answer the second part of your question first, the problem that we have conceptually with using area sampling and personal sampling for evaluating the efficiency of recirculation systems is the time problem that one faces. Looking at the rise time that is normally associated with recirculation system failures, you find that, once there is a failure, you may see rapid and massive increases in toxic level concentrations in the workplace, and relying on personal sampling and area sampling can get you into trouble. Now what we've said is that this should be evaluated, that you should look at what the rise time in fact would be in a particular situation, and if the rise time is sufficiently slow that you can use personal or air sampling, there is nothing wrong with it.

To answer the first part of your question, we, I believe, allowed for that. The "hanging on the ceiling" kind of recirculating system is, as far as one might determine, an area system, and if it was hanging in a room where there were toxic materials and you were relying on it to maintain control over the levels of toxic materials in the room, then it should be evaluated in accordance with the same criteria that apply in more complex systems. Whether that is reasonable or not, I have trouble saying at this point.

The other thing I should have said about that is that monitoring can be very simple depending on how you approach it, and it doesn't, in all cases, require analytical chemistry. Monitoring systems that under some circumstances, some unique circumstances, might be acceptable, could be such things as power failure or circuit breaker indicator, something like that. It really depends on the situation. Where you want to be able to tell when the system has stopped working, and you can do that without getting into carrying little chemistry kits, so much the better.

MR. JEFF GREEN (Kohler Co., Kohler, Wisconsin): Getting back to the question about the monitoring equipment, are you aware of any criteria or equipment used to monitor clean air or return air? I have a problem right now--I'm trying to recirculate some air which is carrying lead dust and trying to find equipment to do that is very difficult.

MR. STRICOFF: The underlying concept of our particular work on monitoring, in our estimation, is that we haven't said a lot of very specific things about monitors and air cleaners, in contrast to the report that Southwest Research Institute did for NIOSH a few years ago. The reason for that is that we felt it was not the most appropriate way to allocate resources that were available. The situation with monitoring and air cleaning is a dynamic one. To take a "snapshot" view of what is available in terms of equipment now is a lot of effort, and if we attempted to do it, by the time we got the work finished it would probably be out of date. Instead, what we tried to do is provide some guidance that really amounts to telling someone what sort of performance requirements should apply to monitoring an air cleaner that is intended for air recirculation systems. If you are going to use an air cleaner you should do certain things. If you are going to use a monitoring system it should perform in certain ways, and what specific kinds of hardware, or even kinds of technology you use to meet those performance requirements is something that is really beyond the consideration--we felt it was one step beyond what we were trying to accomplish.

MR. HAGOPIAN: We also say that unavailability of a monitoring system in cases where there is justified need for one could be cause for concluding that recirculation is not feasible.

DR. DYSON: For your specific problem, the upcoming OSHA standards on lead might completely resolve that for you, since I think they are considering the possibility of prohibiting recirculation of exhaust.

MR. LOUIS DICKIE (DCE Vokes, Jeffersontown, Kentucky): I want to carry the line Phelps Eshelman was on a bit farther, and maybe this is going to be more editorial than question.

I was excited when you began this morning, Bob, with the fact that energy conservation is mandatory and recirculation was a means of doing that. I was a bit disappointed when just a few sentences later you said that this report was neither to encourage nor discourage recirculation. I was even more disappointed with the A. D. Little report, which I think discourages recirculation. It discourages it through what it doesn't say.

One of the speakers mentioned briefly that there is an assumption that all the other ventilation systems in the building have monitors, and that is a false assumption. They do not. The considerable emphasis that this report places on modes of failure and monitors to determine these failures of recirculation systems leaves the impression that this is the only risk involved in a plant. The risk is there without the recirculation if you have failures of the other ventilation systems.

In my mind, the monitor is in the wrong place if it is in the recirculation system. It should be where it measures the air the worker breathes, because the quality of that air is affected by every piece of ventilation in the plant.

I think that in publishing this report, and I can realize A. D. Little's scope was to evaluate recirculation systems, there has to be some sort of preface. It says these safety measures belong to the entire ventilation system any time there are health hazards involved.

Maybe you would want to comment on that, Bob, because I guess that preface is coming from NIOSH.

CHAIRMAN HUGHES: We had a previous discussion on the location of the monitor, as I recall. One thought, and I think maybe Scott and John would want to address this to some degree, is that with the recirculation system you do have a lot of the same problems that you would with a normal ventilation system. If the fan stops working or there is some kind of clogging or blockage to the exhaust, you would have a problem.

The thing that the recirculation system does that the normal exhaust system does not, is that rather than taking that air that has gone through a cleaner and discharging it outside, hopefully in a manner which doesn't reintroduce it, you're introducing that air directly back into the workplace. Any kind of a failure with the air cleaner could create quite the same situation.

Insofar as the method of monitoring, I think that proper procedure for monitoring various situations of recirculation could have almost infinite variations. In some cases it may be required to have very sophisticated monitoring, and in some cases only as much as visually looking at the return and seeing dust particles coming out. Evaluating each individual situation has to be done in a manner which is consistent with that particular system. I don't think there is any other way to say it. Whether the monitor is in the duct or on the worker has to be based on an evaluation of each individual case. I would think that a monitor in a duct discharge is ideal. If that system fails you'll have immediate knowledge of it. If you have combinations of recirculating systems and nonrecirculating systems, yes, the interaction of those systems is going to affect the workplace. In some way you have to monitor the recirculating system. If you have the monitor on the worker, or you're taking a worker sample and the nonrecirculating system fails, you don't know where the failure is.

The worker protection is important, and I think it has to be viewed on an individual basis.

MR. DICKIE: You said you have to have a monitor on the recirculation system, and this puts the stick on recirculation systems as being less safe than other types of ventilation, and that is going to discourage the installation. It puts a penalty on them in the cost standpoint.

Now you can take the same air cleaner, that exhaust-cleaned air outside the building, and that air cleaner can fail and leave the contaminants in the building; but nobody says it needs to be monitored, particularly the fabric collector. The general failure is one of high pressure drop, loss of air, but all of the emphasis is put on the fact that the danger is in recirculating the air, not that it is in other types of failure. I'm not saying there should be no monitor. I'm merely saying monitoring one piece of the total system, specifically recirculation of the local exhaust hood as opposed to space cleaners, is going to put a penalty on recirculation that will cause people not to consider it. The thing that should be monitored is the atmosphere that can be unhealthy to the worker, not performance of a piece of equipment.

CHAIRMAN HUGHES: I believe that any properly operated plant should definitely have a monitoring system to assure that all of the systems are working properly. You would not just monitor the recirculation system alone and ignore the others. I think that by directing the air . . . .

MR. DICKIE: You've answered my question. We both have the same belief. I'm just afraid that the report, to the hundreds of thousands of people that don't have the experience that is in this room, is going to attach a statement of recirculation that will cause them to ignore it, whereas they should have the same types of controls and monitors on their general ventilation, their makeup air, their exhaust, and everything else. That has to be said somewhere or we are going to penalize recirculation of the local exhaust systems to the point that they won't be useful.

CHAIRMAN HUGHES: I think a clarification of that is in order, yes.

MR. JOHN TALTY (NIOSH, Cincinnati, Ohio): I wanted to ask if John or Scott would comment on the statement that was made that the Arthur D. Little report results would either not be able to be used or would in fact not be used by design engineers who would be designing a recirculation system. I think that was most unfortunate.

MR. HAGOPIAN: As you know, we've developed an analytical approach by which design engineers can arrive at general system performance specifications which are optimum for a particular plant area being investigated. It is not going to help them design the hardware, that's true, but it serves the purpose of defining what various flow volumes must be and generally how air should be distributed throughout the workplace. I really don't know what more to say than that. I would like to think that it provides all of the basic information needed for a design engineer.

MR. STRICOFF: To add to that, while it is true the report does contain a fair amount of information that is probably not of interest to the design

engineers, I think it also contains a fair amount of information that is not particularly of interest to industrial hygienists. It is mainly aimed at a full audience. Recirculation isn't something that should be undertaken by a design engineer or industrial hygienist. It is something that should be undertaken by both, and it requires input by both, and cooperative effort by both, and to that end the report is intended to speak to both, and we would hope it would be used that way.

CHAIRMAN HUGHES: With regard to one of Mr. Dickie's original comments on my statement that we were neither encouraging nor discouraging recirculation, I think that was a bad choice of words. What I'm really trying to say is that NIOSH is taking the approach that we want to develop guidelines or criteria, whatever we may call it, to assist people in understanding what the problems may be and how to approach them so that worker health will be considered. We are trying to encourage energy conservation, but our purpose here is to be sure that health is protected.

The other thing I might mention with respect to monitoring and our original intent is that there needs to be some kind of a monitoring device, system, or technique, to assure that the recirculation system, in conjunction with the rest of the ventilation system, is not going to cause a problem. In many cases it is going to be difficult to find the proper equipment, because this type of equipment has not been in demand in the past.

MR. STRICOFF: I don't know if you're familiar with it, but in our draft report we point out and accept with no hesitation the fact that monitoring can be done either in ducts or in workspace. Also, it can be done either manually or automatically, and similarly, it can either be done with contaminant or nonspecific approaches, and we don't pass judgment on any of those approaches. All we've attempted to do is get people to recognize that there are differences, and recognize that there are some types of situations, because of the nature of the contaminant or because of the nature of the physical layout of the workplace and airstream, where specific kinds of monitoring approaches are not appropriate. All that we want to do is help people realize where they shouldn't be doing certain things. We are not attempting to prescribe to people what they should do, because we think that is self-defeating.

MR. ESHELMAN: I don't know if I was fortunate or unfortunate to receive a copy of your preliminary document. The question that has been asked is how can we, the people sitting here, really give an intelligent critique on it when we have not received or even see a copy of this up until today.

Now my other question, or statement, is in response to the gentleman from NIOSH. As a design engineer, I was glad to hear Bill say that he thought the document should stay in the health office, because as a design engineer, I would get discouraged trying to find the information in there that would help me design an exhaust system for recirculation. The information is there. It is in the document. It is buried. You can't find it. Maybe I'm critiquing something here which I shouldn't. Maybe the final report will bring it to light, but it is so deeply buried that as a design engineer I would get discouraged reading it and put it

on the shelf or use it to hold the door open, rather than as a useful tool at the present time.

CHAIRMAN HUGHES: Your comment is well taken. We'll consider these comments in editing for the final report.

MR. JERRY FLESCH (NIOSH, Cincinnati, Ohio): I would just like to point out for the gentleman who asked about the lead problems, that I believe that recirculation has been successfully applied in firing ranges to reduce lead contaminants to acceptable levels, and I have some more information if you would like it.

## A REGULATORY PERSPECTIVE ON THE RECIRCULATION OF INDUSTRIAL EXHAUST AIR

James Lim\*

### Abstract

*The practice of recirculating industrial exhaust air is not widely used in California at present because California's climatic conditions do not make the practice economically attractive. California's current regulations on recirculation are minimal. California's present regulatory posture on recirculation is one of general permissiveness when the recirculation will not result in harmful exposures to workers. It is expected that recirculation will be used more in California as the cost of energy continues to rise. Anticipating this increased use, California views the need to adopt more effective and sensible regulations on recirculation which will provide necessary safeguards to protect employees' health when the exhaust air being recirculated has been exposed to very harmful agents, such as highly toxic or carcinogenic substances.*

When I received a phone call from NIOSH asking if I would come to this symposium and express California's view on regulations pertaining to recirculation of industrial exhaust air, I responded, "I wouldn't know what to say about the subject. I don't think we have any regulations governing recirculation of industrial exhaust air in the work environment. Our only requirement is that the threshold limit value (TLV) not be exceeded. Recirculation of industrial exhaust air is not used much in California, and it is not an issue here." The NIOSH caller said, "That's fine. Just say that at the symposium." I suppose that I could end my presentation here, but I hardly think this would justify my airplane trip to Cincinnati.

The recirculation of industrial exhaust air is not used much in California because our climatic conditions generally do not warrant it. Although parts of California have extreme ambient air temperatures, such as Death Valley, most of our industrial activities are concentrated in areas where the climatic conditions are temperate. The economics of installing and operating industrial exhaust air purifying equipment generally cannot justify recirculation in California where the makeup air requires little or only moderate tempering. We do not have the same situation as the midwest or northern parts of the United States where there are much greater differences in climatic conditions,

---

\*Supervising Industrial Hygiene Engineer, State Department of Health, Berkeley, California.

and where the workplace atmosphere requires substantial heating or cooling. Hence, the recirculation of industrial exhaust air for the purpose of conserving energy has not been a significant concern or consideration in California as it has been in other parts of the United States. However, with the rapidly rising cost of energy and increasingly stringent air pollution regulations requiring the cleaning of externally discharged air, I believe that the practice of recirculating industrial exhaust air in the work environment will become a more attractive and significant consideration in California.

To find out just what regulations California does have on recirculation of industrial exhaust air, I made a search through our General Industry Safety Orders. For those who do not know, California is an agreement State that operates its own OSHA program, and California has its own occupational safety and health standards, unlike most other agreement States that have just adopted the Federal OSHA standards. All of our Cal/OSHA standards and regulations are embodied in a series of safety orders, such as the "Tunneling and Mining Safety Orders," the "Construction Safety Orders," and the "General Industry Safety Orders." Our General Industry Safety Orders, which are in a book more than 2 inches thick, are at least as effective as the Federal standards, and in some cases, more stringent and more comprehensive than the Federal standards. In going through our General Industry Safety Orders, I found two situations or processes where the recirculation of industrial exhaust air is specifically prohibited. Section 3245(f) of California's General Industry Safety Orders prohibits the recirculation of exhaust air from motion picture projection booths, and Section 5153(c) prohibits the recirculation of exhaust air from flammable spray coating operations.

The other sections in our General Industry Safety Orders that refer to recirculation of exhaust air are permissive in nature. Section 5143, which specifies the general requirements for mechanical ventilation systems, has a paragraph "c" which states, "Collecting systems which return air to work areas may be used if contaminants which accumulate in the work area do not result in harmful exposure to employees." Section 5152(a) pertaining to grinding, polishing, and buffing operations states, "Every establishment performing dry grinding, dry polishing, or buffing shall provide suitable hoods or enclosures that are connected to exhaust systems which are run continuously during operations. Exception to this requirement will be made when the concentration at the operator's breathing zone of any airborne contaminant generated by such an operation is below the applicable limit prescribed in Section 5155 or any other section of Title 8." This means that the exhaust air from grinding, polishing, and buffing operations may be discharged into the work environment dirty, as long as the threshold limit value is not exceeded. Even our standard regulating carcinogens states that the exhaust air shall not be discharged to regulated areas, nonregulated areas, or the external environment, unless decontaminated. This means that carcinogen-exposed air which has been decontaminated may be recirculated.

As you can see, except for motion picture projection rooms and spray coating operations, California's present regulatory posture on recirculation of industrial exhaust air allows the practice if the recirculation will not result in harmful exposures to workers. The regulation prohibiting the recirculation of exhaust air in motion picture projection booths is an old California regula-

tion which was instituted to protect the projectionist from exposures of excessive ozone and oxides of nitrogen produced by the projector equipment. California's regulation prohibiting the recirculation of exhaust air from flammable spray coating operations is patterned after a Federal OSHA standard (1910.107, paragraph D9) as an "at least as effective as" standard.

I believe that California needs better regulations on recirculation of industrial exhaust air that will provide more protection of worker's health, even though recirculation is rarely used in California at present. An incident I recall illustrates California's regulatory deficiency on recirculation. About a year ago, an architect telephoned me to verify that Cal/OSHA had no regulations which pertained to the recirculation of exhaust air from polishing beryllium alloys. He said that he was designing an air conditioned dental office building which would include a large dental laboratory. The dental laboratory would manufacture dentures using alloys which contain beryllium, and the manufacturing operations would involve extensive grinding and polishing of beryllium alloys. He said that he was planning to return the exhaust air from these operations into the general air conditioning system of the building after passing the exhaust air through a high-efficiency filter. He wanted to recirculate the air to conserve and minimize air conditioning requirements. I asked him if his plans included fail-safe filter equipment and monitoring for beryllium-contaminated air. He said that he was not planning any unless it was required. Then I explained to him the severe health hazard of beryllium dust, and advised him to design the dental laboratory so that the beryllium alloy polishing operations would be isolated and confined in a separate room with a separate ventilation system and no recirculation of the exhaust air. I do not know if the architect followed my advice.

In discussing the need for better regulations on recirculation of industrial exhaust air with my industrial hygiene colleagues in the Cal/OSHA program, there is general agreement that recirculation should be permitted, but that there should be provisos, such as restrictions, requirements for fail-safe equipment, air monitoring, etc., to protect employees' health when exhaust air that has been exposed to very harmful agents, such as highly toxic or carcinogenic substances, is being recirculated. Since the practice of recirculation is not widely used in California at present, California has not given any priority to the development of better regulations on recirculation. But we expect recirculation to be used more in California in the future, and we are grateful that NIOSH is supporting activities, and symposiums such as this one, to provide the information necessary for development of effective and sensible regulations on the recirculation of industrial exhaust air in the work environment.

#### REFERENCE

1. "California Administrative Code," Title 8, Division of Industrial Safety, General Industry Safety Orders.

## DISCUSSION

MR. WILLIAM HALL (Quaker Oats Co., Chicago, Illinois): I want to comment on one word he used that I thought was most appropriate, and I hope is never forgotten: sensible.

MR. DON SCARBOROUGH (Nordson Corp., Amherst, Ohio): We keep hearing this word "monitoring" cropping up, and I get an implication from the way it is used that we are referring only to instrumental monitoring. I do hope that not only the gentleman from California, but the entire panel here today, recognizes that the human being is a monitoring device and that sight and smell are often far superior to instrumental means available to determine that something just went sour with the ventilation system. I do hope that it is recognized as a viable system of operating, in a sense, as appropriate.

MR. LIM: We in California are open to whether monitors will be required or not. However, I personally think that some of the better candidates for recirculation would be the strong irritants, you know, where the main toxicological factor is irritation. With these substances, monitors may not be necessary, because you'll know if your system isn't working.

CHAIRMAN HUGHES: I might add just one thing to the use of irritants for a monitoring system. I think that irritants may be utilized, but only to supplement some kind of a more positive means, because there is a great difference in the susceptibility of different people to irritants. One of the thresholds can vary considerably. There is no question that if something is an irritant it is going to be an aid, but it can't be used as the sole method.

MR. STEPHEN MESSINGER (OSHA, Cincinnati, Ohio): I would like to make comments on the recirculation of air with the possibility of lead contamination. When you recirculate you're going to have lead throughout the whole plant instead of just one area. You're going to have to deal with it, and you're going to have to monitor with samples, and you're going to have to be sure the other employees are protected. This would go for other contaminants with ingestion hazards.

CHAIRMAN HUGHES: One thing I might mention--I was going to mention it later in more detail--is that NIOSH is conducting validation efforts in conjunction with recirculation. These are just getting under way. In fact, Mr Bullock from Envirex will be speaking tomorrow morning about one of our efforts. In this effort, we are looking at an area in recirculating lead. I don't know whether he is going to discuss that or not, but we have a situation where it is being done, and apparently is effective.

PANEL DISCUSSION:

OVERALL ASSESSMENT OF CRITERIA DEVELOPMENT

Panel Members: Robert T. Hughes  
John Hagopian  
R. Scott Stricoff  
William L. Dyson  
James C. Barrett  
James Lim

CHAIRMAN HUGHES: Our panel discussion will give you the opportunity to ask questions and make comments, even on points that may not have been specifically addressed thus far.

MR. BRUCE MENKEL (Bruce Menkel Consulting Engineers, Dayton Ohio): I have a question for the Arthur D. Little people in regard to modeling. I would like for them to explain a little bit more what they went into and if there is any correlation with actual installations.

MR. JOHN HAGOPIAN (A. D. Little Co., Cambridge, Massachusetts): The validation studies NIOSH is supporting will involve field studies to see how these models work when applied. As far as my giving you more details on the models, that is verbally rather difficult. Basically, the two equations I presented for the concentrations before the air cleaner and for the return air are supplemented by a set of equations which are for flow balances within the plant area. Also used are the breathing zone equations, and then a cost function. Most of the parameters in these equations are concentrations or flow volumes, some of which existed before recirculation was implemented. Some are left to the whim of the designer using the equations. These latter variable parameters are adjusted until you get an optimum cost for a system configuration which is acceptable in terms of safety and health considerations. Of course, the efficiency of the air cleaning section is also included in this procedure.

CHAIRMAN HUGHES: There is a program ongoing to validate these criteria guidelines with respect to actual installations. This is being done by contract. Arthur D. Little is involved, and so is Envirex in Milwaukee. As I mentioned before, Mr. Bullock from Envirex will be speaking to us in the morning regarding the validation method, but the areas that are currently to be included are: lead operations, woodworking, cleanup room, rubber tire manufacturing, home plating operations, and some metal grinding operations. These are ongoing and total effort will be done in about another 11 to 12 months.

MR. WILLIAM HUELSEN (American Foundrymen's Society, Des Plaines, Illinois): There are many of us here who are interested in how you translate what is

contained in the report, which is to a great extent quite theoretical, into a practical ventilation system. How would you approach it, Jim, and how would you monitor it so that we would have acceptable air quality in the workplace, and what limitations might you place upon the system?

MR. JAMES BARRETT (Department of Health, Lansing, Michigan): Let me take the second part of your question first. I've not seen the report, so I cannot be specific to its contents, but I would say that in my opinion there are some limitations in modeling, because there are many different ways of putting together ventilation equipment out in the real world. It depends on the size of the plant, the type of operation, and so forth. So, until I knew better, I would look at the equations as depicting the variables which have to be considered, and their relationships. I certainly would not ascribe any precision to them at this moment, because I simply haven't seen them, for one thing. Remember that the Threshold Limit Values, the OSHA permissible exposure levels, and these guidelines and legal requirements are also rather imprecise. As you go back to the preamble of the ACGIH Threshold Limit Values, you see that they are intended to be guidelines and they are not defined specifications as to what condition may or may not be healthful; they are supposed to be used with some judgment. On that basis alone I can say that the guideline equations would have to be used with considered judgment.

Once the system is designed, depending upon the nature of the system, the contaminants we are concerned about, and the consequences of failure, you can determine the initial amount of surveillance to set up as the study program is developed to determine whether or not the approach is feasible.

Following that, when the system is installed, I think the type of surveillance depends again on the system, and other ventilation systems in the space. There are general ventilation systems and makeup air systems, natural ventilation systems, as well as a particular local exhaust system under consideration for being recirculated. The actual surveillance might be simply pressure drop surveillance over the operation of the system or it might be area monitoring, as we talked about the last time this group met a couple of years ago. Don't forget that there are some OSHA standards coming down the road--when, I can't say--that will require some personal monitoring for different contaminants. These are all additional variables that have to go into the design as to how you're going to evaluate the system overall.

CHAIRMAN HUGHES: We've had some discussion earlier this morning about the difference between workplace, personal, and duct monitoring in regard to the recirculation system itself. Do you have any comment, Jim? I'm speaking of a method by which you assure yourself of a healthy recirculation system.

MR. BARRETT: Well, we are back to what I said a few minutes ago. Some of the personal monitoring may be laid upon all of us, if you will, as the OSHA Standards Completion Project comes around, which contains some specific provisions for personal monitoring. Trying to deal with it objectively, the choice of monitoring would depend on, first of all the toxicity of the material, which determines the consequence of error, or failure, and also the expected rise time in the concentration. This, of course, is a

function of the recirculated air volume with respect to the volume of air in the space and other ventilation systems. If the material is highly toxic, and if it were expected to have a rapid rise time in concentration with serious health effects, then I would think that duct monitoring may be required. That is subject, of course, to the availability and the limitations of the equipment. We have a pretty good idea where we stand on that. It is very spotty, to my knowledge. Area sampling is one method of monitoring in industrial hygiene. We used to take not only personal samples or breathing zone samples for the workers' exposure, but also general area samples, as we call them, to get an appraisal of the miscellaneous sources of contaminant which may be outside the control area of a particular system. Then personal sampling may be a legal requirement with some standards. Those are the things that I would consider in trying to select between personal, area, and duct sampling.

MR. TOM BLOOM (NIOSH, Cincinnati, Ohio): Mr. Lim, I have a question for you. Are there situations which you've uncovered in California where the presence of exterior pollutants, and I'm referring specifically to the Los Angeles area where they have air quality problems, can affect the function or efficiency of a recirculation exhaust system?

MR. JAMES LIM (State Department of Health, Berkeley, California): As you all probably know, the air can get pretty bad sometimes in Los Angeles. I'm not aware of any situation involving recirculation where the outside air is a problem. But I can see where it can be, because along the L.A. freeways, the CO concentration frequently will get up to peak well over 50 ppm.

MR. BLOOM: Since the air quality does vary around the country, is ambient air quality a factor to be considered in the feasibility of recirculation exhaust systems?

MR. LIM: I would certainly think so.

MR. BLOOM: Did Arthur D. Little consider this factor?

MR. HAGOPIAN: Yes, we did. In the equations I presented and in all of the figures which I had on slides, one of the parameters of interest is the concentration of contaminant in the makeup air. If you're worried about CO levels in the workplace, or if you're generating CO, you can look at what the CO level is in incoming fresh air and take it into account.

MR. BARRETT: I would like to add that it would have potentially more effect on the typical once-through type of ventilation system, where you might be contaminating the fresh air intake. If you were in a very highly contaminated area you would then perhaps have the option of putting a very high quality air cleaner on the air intake. In one plant in Michigan a number of years ago, the outside air quality was so poor around their office that they had a pulse jet industrial dust collector to clean the fresh air supply to the office. That is one example I know of. So if you're in that type of a situation you can conceive of a hermetically sealed plant with whatever is necessary for recirculation

systems, and then high quality air cleaning for a little bit of fresh air pressurized into the building, but that would be an extreme case.

MR. LAWRENCE BULLOCK (Envirex, Milwaukee, Wisconsin): Since I haven't had an opportunity to look at your report in more detail, I would like to ask if you could talk a little bit about some of the assumptions you need when developing your model. In particular, when you attempt to measure the baseline level of contaminants you say that you like to look where your worst case, area, or employee is on which to base your decision to recirculate. In terms of fluctuating levels in all mechanical plants, did you state how the stated assumption might be an interim when you assume these conditions?

Secondly, you made some other assumptions that before you can attempt to recirculate, all air mechanically abstracted from the plant should be mechanically made up. You're assuming perfect air balance in the plant when you start. I have yet to see a plant that does this. Could you address some of the assumptions you made to some realistic situations?

MR. HAGOPIAN: We discuss fluctuating processes and realize they cause a problem. If the fluctuations are not over a large range, we indicate that time-averaged values may be used. If they are wide, we make the point that the system should be designed for the worst case, let's say during some time period when the majority of the processes are in operation, again using averages. This is for initial design purposes only.

The report further indicates that when you do have such fluctuations, and if your contaminants have ceiling limits, you have to spot check breathing zone concentrations, using the model, to assure that you don't violate ceiling limits. This would be done by using the model with peak concentrations experienced. The model can also be applied on a real-time basis, if need be. If you have a process emission profile, you can plug the data into the model point by point and obtain corresponding breathing zone concentrations.

In regard to the perfect air balance assumption, we comment that a balanced air system is preferred practice. If the plant does not have a balanced air supply before recirculation, this can be accounted for in equations. But while recirculation is being implemented, we strongly suggest that a balance be obtained.

MR. GORDON ROUSH (Dow Chemical, Midland, Michigan): I would like to find out how far ahead NIOSH is, assuming that eventually a standard will be issued, on recirculation of air. I would like to ask a couple of questions to some specific instances and find out if you've given any thought that might allow us to plan ahead.

I work in an office building where the air is recirculated, and I'm wondering if that air would also have to be monitored in case of, for example, smoking. Nonsmokers might very much like to have their air monitored to make sure they are not overly exposed to cigarette smoke, carbon monoxide.

Have you given any thought to whether certain areas would be exempted? But if as long as you have recirculated air does that mean you have to have some sort of monitor?

CHAIRMAN HUGHES: As I indicated earlier, we are not developing this information for the setting and promulgation of standards. I cannot say whether OSHA or the State governments would feel that certain restrictions or regulations might be imposed on recirculation. I would presume that in some cases they may, such as carcinogens. The NIOSH work has assumed that carcinogens should not be recirculated. I think this is carried into the OSHA standards. It was discussed earlier that the OSHA proposed lead standard may prohibit recirculation.

As far as monitoring is concerned, I don't know whether this would be required by OSHA or the State regulatory agencies.

Insofar as office space is concerned, we've not addressed any of our efforts to that in this program, and I'm not foreseeing that in the immediate future we would address the office area and smoking in particular. Our work is oriented toward the industrial workplace, not the office.

MR. BARRETT: I say at the moment we don't have any thoughts on limitations on heating-ventilating systems, which is basically what we're talking about in offices where a certain amount of air is recirculated and a certain amount is brought in from outside. The question you raised about smoking is one that sooner or later all of us will have to address. It has received a lot of attention nationally and in our Michigan legislature. We all know we can't ride on an airplane and smoke wherever we want to. We've had very few problems with office ventilation systems, and the problems we've had are generally due to thoughtless installation. One that comes to mind is the heating system for the offices and showrooms of three or four automobile dealerships where the air intake unfortunately was from the service part of the building, which meant that carbon monoxide released from the automobile service area made its way into the offices. It is this type of problem we've seen, rather than any overall general problem.

MR. LIM: As I said earlier, we in California are open to the question of whether monitoring is required or not, but in a sense we have no choice in this matter because we are in an agreement State. We are required to have regulations which are at least as effective as the Federal regulations. So if OSHA requires monitoring, then we will have to follow suit. We won't have any choice in the matter. But as far as my personal views go, I oppose any unnecessary monitoring, like monitoring of the office atmosphere with respect to cigarette smoking. That is just too unreasonable.

MR. ROUSH: If we were monitoring a plant that had recirculated air, had not seen any buildup, and the employees were not exposed to the contaminant we knew we emitted into the building, in other words, the contaminant level was not apparently building up in the area, we would not need to continue monitoring of the ventilation system or air monitoring, or personal monitoring; is that right?

MR. SCOTT STRICOFF (Arthur D. Little, Inc., Cambridge, Massachusetts): I would pose a question to you in response. If I monitored my plant today and found that there was no buildup, how would I know tomorrow the air was the same?

MR. ROUSH: We monitored perhaps twice a year for several years.

MR. STRICOFF: The fact that the equipment hasn't failed in the last 2 years doesn't mean it won't fail in the next 6 months, and may mean that it is more likely that the equipment will fail.

MR. ROUSH: What I'm referring to is that the plant doesn't have any sort of air cleaner for contaminants. We've not seen any buildup. We do have recirculated air, with a little bit of makeup air added to it. Now I'm assuming in that case that as long as we are not exposed, we needn't have to worry about monitoring the ventilation system.

MR. STRICOFF: Let me make sure I understand you. You have no air cleaner. You are recirculating without an air cleaner?

MR. ROUSH: Yes, other than a particulate filter you might find in any ventilation system.

MR. STRICOFF: Okay, then assuming that you have no toxic dust present, then the situation that you're in would lend itself to a visual air monitoring system and I think it would be perfectly acceptable.

MR. BARRETT: I'll try to give you a legal answer. So long as employees are not exposed to concentrations above the permissible exposure level, the system would be acceptable. Professional judgment should come in here. We look at the NIOSH criteria documents. We look at the ACGIH TLV's, which have been updated considerably since 1968, we look into the NIOSH compilations of toxic substances, and we research the literature.

I might add here, our State is like California in that we are an agreement State of OSHA. We have adopted all of OSHA's regulations by reference. That is our legislature's desire. But we did hold over some of our own State standards along with OSHA standards, and in particular on the subject of recirculation, we have a requirement that you have to have a bypass duct outdoors. As a matter of practicality and policy we exclude small unit collectors from that particular requirement. But the reason we require the bypass duct is that, if there is a failure of the collector or some other part of the system, the exhaust would be burdened and the operation could become hazardous to the employees. Without stopping the system, the bypass duct could alleviate a hazardous situation.

One of the things I didn't think received a great deal of attention this morning, and not too many questions, but that I hope will be stressed in the report is the necessary maintenance that will be required, recognizing that many people have ventilation systems or other control systems.

MR. HAGOPIAN: There is an entire chapter devoted to that subject that basically outlines what must be done. Specifically, it describes which items must be periodically checked, inspected, tested, etc., and notes that recordkeeping is necessary, that a maintenance plan must be developed, and that such a plan should be based upon the recommendations of the equipment manufacturers.

CHAIRMAN HUGHES: Any plant that has any kind of process which emits a toxic hazardous material is going to have to have some kind of a monitoring scheme, whether it is recirculated or not. Just good practice will demand that. The monitoring that we are talking about in this report of recirculation does not in any way preclude or change that necessity. We are talking here about monitoring, or some kind of a sampling technique, to determine if there is any problem with that recirculation system that could be harmful to the worker.

MR. LARRY JOHNSON (Chevrolet, Warren, Michigan): Mr. Barrett, based on NIOSH criteria, you can recirculate processed air if your cleaning device removes 90 percent of the contaminant. Do you accept the manufacturer's guaranteed results?

MR. BARRETT: Well, first of all, let me say that that particular requirement was written pre-OSHA. It came down to the question of whether or not the workers were overexposed. By OSHA standards, exposure standards would apply, whether the discharge concentration was 10 percent of the TLV or not. That relates to all of the other variables. As to where we would get that information, as to what discharge concentration might be, we would of course rely heavily on the manufacturer's data taken from similar installations, particularly test data, if that were seen necessary, and then if we had questions we would ask to have a test run to be sure.

MR. JOHNSON: You then wouldn't require a monitoring device on recirculated air?

MR. BARRETT: I think, number one, any type of engineering control system needs some kind of surveillance, even if it's just routine pressure testing of ventilation systems to see if they are up to snuff. In recirculation systems, the monitoring or surveillance requirement might be as simple as a standard pressure tap to be sure the volume is maintained; or a little more complex, e.g., a flow switch that might discharge the air outdoors--static pressure control would do that--if the nature of the contaminant and the expected degree of worker hazards indicate that; or very complex systems for something that might potentially contain concentrations of highly toxic substances.

MR. MENKEL: The two gentlemen from Arthur D. Little this morning indicated it was their feeling, and actually a premise of their's, that an endeavor under any circumstances to recirculate a contaminant, such as a carcinogen, back into the plant should not be allowed. I would like to have the opinion of the other members of the panel on this.

MR. STRICOFF: I just want to clarify that. What we intended to say was that in writing a general guideline for people interested in recirculation, we would write, as that guideline, you should never recirculate carcinogens. There is a distinction between saying that, at least the way I look at it, and saying that one should, for example, write an OSHA regulation saying nobody should ever, under any circumstances, recirculate carcinogens. The difference is that one has to be careful about who makes the evaluation and the decision that, yes, this is sufficiently safe and the

contaminant characteristics are such that the recirculation of the carcinogens is okay. In writing general guidelines, we were not prepared to say, well, you should think about it and make a decision. We are on much firmer ground saying don't do it, but that doesn't preclude the possibility of exceptions.

MR. LIM: In regard to carcinogens being recirculated, even if the air is decontaminated, we in California feel that there is no absolute assurance that the air is completely decontaminated, so we would be very reluctant to accept any system that recirculates carcinogenic, or carcinogen-exposed air.

As I said earlier, recirculation is rarely used in California because the economics do not justify recirculation, and I just don't see the recirculation of carcinogens being practical in California because the system that we would require would just be too costly.

DR. WILLIAM DYSON (Burlington Industries, Greensboro, North Carolina): In further response to your question, there are several classes of carcinogens, and by this I am referring specifically to those for which standards are set up and accepted and those for which there are no standards at present. If we accept the premise that you can recirculate as long as the worker is not exposed to material above the threshold limit value or the OSHA standard, then those carcinogens, such as nickel, which have standards set for them, would be acceptable to recirculate. And in addition to that, you see the possibility of excluding from recirculation any contaminant you don't want recirculated just by requiring monitoring capability--this is particularly true of carcinogens if you require specific monitoring.

MR. HUELSEN: I would like to address my question primarily to Bob Hughes about the carcinogens. We have had published in the Federal Register proposed levels for nickel, and in the bare scrap we buy in the foundry industry, our metallurgists tell us there is about 2 to 3 percent nickel; whether you want it or not, this is what is coming in. You have under contract a study on foundry cleaning rooms and on grinding, buffing, and polishing operations. If we know we are getting this 2 to 3 percent nickel in the bare scrap, whether we want it or not, and we begin grinding, we are going to have airborne dust containing metallic nickel. Now how much of that nickel is going to oxidize, we don't know, but nevertheless, the analytical technique will be to take what is on the filter and look for nickel. Well, here we are talking about a suspected carcinogen. How should we proceed? Should we abandon thoughts of recirculating air in the cleaning room, or should we proceed and perhaps have to take some of these systems out in the future?

CHAIRMAN HUGHES: I think that particular dilemma would apply to more areas than just nickel. We spoke of lead earlier. At this time I don't know how to respond, because we don't know what the regulations will be. For instance, when we first started to work on recirculation with Arthur D. Little, the thought was that we would consider all materials and all chemicals as being potential to recirculation except those which were identified by OSHA as carcinogens, and those are the only ones, of

course, that have restrictions. But as we got into this study and we looked more and more into the quite large list of things which are potential carcinogens, it raised quite a dilemma. I think the only thing that we can look at right now is if the material has carcinogens in it and it can be detected and measured and controlled to that level, then it probably would be suitable for recirculation.

MR. HUELSEN: Could I address the limit question? In the Federal Register it states that the limit is set because this is the level of detectability. Now if someone devises a means of detecting nickel at a lower level, the implication is that the standard will drop to this new lower level. So we are concerned with 15  $\mu\text{g}/\text{m}^3$  according to present standards. If the limits of detectability later drop to, say, 1  $\mu\text{g}/\text{m}^3$ , then the implication is that the Permissible Exposure Level (PEL) will drop down there, and I think that in light of the Delaney Clause, we have to be concerned.

CHAIRMAN HUGHES: If you want to project into the future, you probably would be precluded from recirculation because if you control today to the detectable limit, and that detectable limit goes down, then you would not be meeting the levels.

UNIDENTIFIED: If the results of the discussions and research into recirculation exhaust systems proceed to development into an efficient system, I think you can anticipate that there might be a rush by employers to install and buy equipment and manufacturers to manufacture the systems. I think naturally this might raise questions as to the integrity and efficiency of these systems, particularly by employee group unions. Has it been considered a possibility to have "certification programs" for recirculation exhaust systems; if it hasn't, should it be considered?

CHAIRMAN HUGHES: There has been no such thought, and I'm not too sure that there is going to be any thought.

DR. DYSON: From what I see and what I know of industry, I don't believe there should be any worry that there will be an uncontrolled rush to install recirculation systems. There are far too many constraints and there are also means of conserving energy just as applicable, which are not the subject of this symposium.

UNIDENTIFIED: The point I wanted to bring up was that recirculation is an attempt to reduce the contaminant by a cheaper system, not necessarily in quality but in dollars, because of our considerations for energy. I think that going on this, employee groups are extremely reluctant to accept what they consider to be inferior systems, and I think that the more recirculation exhaust systems are available as alternatives, the more we are going to have to sell them to employee groups. I think this is going to raise a few problems with selling the product to the employee.

MR. STRICOFF: I'm not sure that anybody here wants to sell them. Our objective is not to sell recirculation. It is merely to make sure that, if people are going to do it, they are not going to hurt other people in

doing it. The selling aspect is something I would suspect NIOSH would not be particularly anxious to be involved in.

MR. JOSEPH KUKLA (Sentry Insurance, Stevens Point, Wisconsin): I think you brought up a very good point, which we have been touching on. This selling is education. I've seen insurance carriers who were reluctant to insure double risk of exposure. I see a lot of nuisance claims with employees coming out with chest pain, even though they smoke four packs of cigarettes a day, saying, "They recycle that air, I'm exposed." I can see product liability suits where this monitor, or whatever system you're using inside the duct, fails, and you have an employee sue for quite a bit of money from the manufacturer. The monitor on the stack into the park is one thing, and into the workplace is another.

DR. DYSON: Since this is a panel discussion, possibly the panel could make a comment that is not in response to a question. There are probably two or three other areas of the model on recirculation that aren't addressed by the Arthur D. Little report, and I would like to mention those very briefly.

First, the report does not consider the effects of air cleaning on the work environment. Two examples would be where a wet collector is used as a cleaner, and where you are using some type of air cleaner such as a catalytic convertor, or burning process. It increases the temperature and humidity within the work area.

Second, the model does not address the removal of contaminant by internal surfaces within the work environment, such as settling of particulates on the surfaces inside; again lead is an example of this. In general, as the calculations go, using the model would be conservative, which is desirable.

And third, there is in my opinion a problem with input to the model for those sources of contaminants within the working environment which do not have local exhaust systems. As the model is written right now, this is to be taken care of by the initial monitoring for determining  $C_{BZ}$ , the breathing zone concentration of the worker. Increased air movement from the recirculation system may increase generation through volatilization of contaminants in the working environment that are not controlled by exhaust systems.

MR. HAGOPIAN: As far as any changes which might be caused to the airstream by the air cleaner, I agree wholeheartedly that this issue must be given consideration. If you want a dry atmosphere, you shouldn't use a wet collector, obviously. I guess if you're having problems with what we said on this subject, we haven't addressed the issue as clearly as it should be.

The next item mentioned was that we don't take into account the settling of particulate matter. That's true. It would be a complicated issue requiring knowledge of settling velocities, exposed room surface areas, and a host of other factors. The model assumes that the same amount that settled before recirculation will settle after recirculation. For uncontrolled sources within the workplace, we assume that the generation rates before and after recirculation will be the same, and that these can be accounted for through accurate determination of breathing zone concentrations before recirculation is implemented.

MR. BARRETT: Someone said this morning that recirculation is rather novel.

It is not. We've had recirculating exhaust systems in Michigan for years. One of the advantages of having the bypass duct is to get rid of exhaust heat and humidity when they are undesirable. I know some systems in Michigan that recirculate from cast iron machining through wet collectors, and return the air to the plant in the winter when the heat recovery is important and when the moisture doesn't cause any problems; in the summer bypass ducts are open and the air is discharged outside, eliminating the humidity and heat. Heat can be a problem not only with catalytic types of units. I remember some years ago I responded to a request for help in a woodworking plant. They had a large fabric collector connected to woodworking machines. They were complaining of being hot inside the plant in summer, and the temperature rise through the ventilation system from the hood through the collector and the fan was something in the order of 15 degrees. By installing simple bypass ducts they could exhaust for the summer; they got rid of certainly not a heat stress problem but a comfort factor in this case. So I do stress the use of bypass ducts, not only from the standpoint of equipment failure, but for some of the other reasons that Bill mentioned.

MR. STRICOFF: I go back a little bit to an underlying part of the question the gentleman from Dow raised. I'm sure a lot of people here are concerned, as are we, that OSHA may attempt in the relatively near future to regulate recirculation, and I think it is worth mentioning specifically that the objective of the work that we did was not to develop anything that would be close to promoting standards or writing standards, or a basis for a standard for OSHA. Our objective was to provide guidelines for the target audience of users. It would concern me quite a bit if I felt that OSHA was, in fact, seriously using this information as a basis for a standard, but I don't think they are at the present time.

MR. DAVID J. BURTON (D. B. Associates, Salt Lake City, Utah): I guess they say there is nothing new under the sun, when we know we've had recirculation systems in our APAC building ventilation mechanical systems for years. There presumably are a number of specifications that already exist for recirculation: the ASHRAE specifications, the building codes, NFPA codes, and so forth, and the one that comes to mind is the ASHRAE specification for 15 ft<sup>3</sup>/min per person of new air for recirculation. I wondered if your guidelines took into account the existing specifications and regulations.

MR. HAGOPIAN: Am I correct in assuming that when you're talking about existing specifications you are referring to ASHRAE recommendations?

MR. BURTON: Well, I'm referring to ASHRAE and any others that may exist. Did you look into that problem to find out if any others do exist, and to what extent is their effort?

MR. HAGOPIAN: In regard to the volumes of air handled, I think the right answer would be no, we did not. We assumed that if you're controlling toxic contaminants, the amount of air you're handling is substantially more than that amount necessary for the purposes such specifications address.

MR. BURTON: Not necessarily. On an old exhaust system you might have a small volume problem in controlling the handling.

CHAIRMAN HUGHES: In response to that, the standards you mentioned from ASHRAE are more oriented toward the office building, the home, and things of that nature. We are not addressing this study to that. This is to what we call the industrial workplace, where there are industrial processes of contaminants. I don't think you should give consideration, per se, to the idea of air changes per minute or per hour when you're talking about exhaust systems and certain airflows required to capture and remove contaminant. I think there was an effort to look at State regulations, where State regulations may occur.

MR. STRICOFF: What we are concerned with is principally the State regulations that were oriented toward safety and health rather than ASHRAE.

MR. KEN SCHOULTZ (Enviro Control, Rockville, Maryland): I was curious as to whether you considered for recirculation the fact that you might be altering the nature of the exposure. In other words, whether you will be building up a concentration of fine particles, and actually destroying the criteria for which possibility the TLV was based, that being the normal evolution of particulate for a given industrial process.

MR. HAGOPIAN: Actually, you're asking two questions in one. One of them has to do with whether we consider the fact that recirculation may increase the level of fine particulates. The other asks whether a change in size distribution may affect the validity of any permissible exposure limit.

We give you quite an involved example in the report where we were looking at silica dust. It shows that even if you filter out most of the large particles, you can wind up recirculating more fines and get significantly more fines in the breathing zone. The example assumes, however, that the TLV for silica dust is correct.

MR. STRICOFF: Now we come to the hard part. The answer to the second part of your question is basically no, we did not explicitly concern ourselves with the fact that by changing the particle sizes we might be in fact destroying the basis of the TLV. That is an interesting point, I think a good point, but not one that we specifically address.

MR. WILLIAM CHENEY (United Air Specialists, Cincinnati, Ohio): I haven't heard any mention of the suggested criteria of discharge from air cleaner being limited to one-tenth of the TLV. Is that still the criteria that is mentioned, or are you going to drop that?

CHAIRMAN HUGHES: That criteria was not included in this study. We set the criteria that the end result of the total circulation system will not raise the level of the contaminant above the threshold limit value or some other value which has been selected in the design.

MR. STEVE CHANSKY (GCA Corporation, Bedford, Massachusetts): In regard to the question raised about the changing particle size distribution, in reading over the proceedings of the conference in 1975, I talked to Milt Caplan. I referred to some studies under sponsorship by EPA, which interestingly

show that the particle size distribution downstream of filters was not much different than particle size upstream of filters, and this is primarily because the particles that get through--and I'm simplifying this, of course--are due to faults in the fabric, itself, so that those that do get through retain much the same distribution as before. This is of course limited only to fabric filtration, not the mineral filtration.

Faint, illegible text at the top of the page, possibly bleed-through from the reverse side.

## INDUSTRIAL ENERGY MANAGEMENT

Richard H. Stephens, Ph.D.,  
Herbert M. Kosstrin, Ph.D., and  
Dimitri E. Pavlakis\*

### Abstract

*Ten years ago we didn't know we had an energy problem. We seemed to have all the resources we needed. This paper delineates some commonsense guidelines on energy management that are necessary to make sure that 10 years from now we will still have the energy that we need to run the Nation.*

### THE ENERGY PROBLEM

Since the Arab oil embargo in 1973, a lot of information has come to the surface concerning the present energy situation and alternatives for becoming self-sufficient in future years. More recently, the focus of the energy situation has been on President Carter's National Energy Plan, submitted to Congress on April 20, 1977 (ref. 1). A review of the National Energy Plan places in perspective where we were headed before we became enlightened about the energy problem, and where we believe we need to go in order to survive until new, renewable sources of energy can be developed.

#### Reduce Energy Demand

The annual growth rate in energy demand has been 4 to 5 percent over the past decade, as shown in figure 1. In contrast, the National Energy Plan calls for reducing the growth rate to less than 2 percent. This is a short-term goal, one which could only be achieved through effective energy management, particularly focusing on energy conservation.

#### Switch to Coal

A further goal of the National Energy Plan is to develop our coal resources and reduce our dependence on oil and natural gas. Note, for example, that the United States was energy self-sufficient as late as 1950. But since that time, energy consumption has increased at a rate faster than our domestic energy production. Natural gas consumption has been exceeding new discoveries since 1968. The production of crude oil has been declining since about 1970, and even with the discoveries in Alaska, domestic oil production is still in a

---

\*Dr. Stephens is the Manager of the Energy Systems Division, Dr. Kosstrin is the Manager of the R & D Program, and Mr. Pavlakis is a mechanical engineer at Energy Resources Company, Inc., Cambridge, Massachusetts.

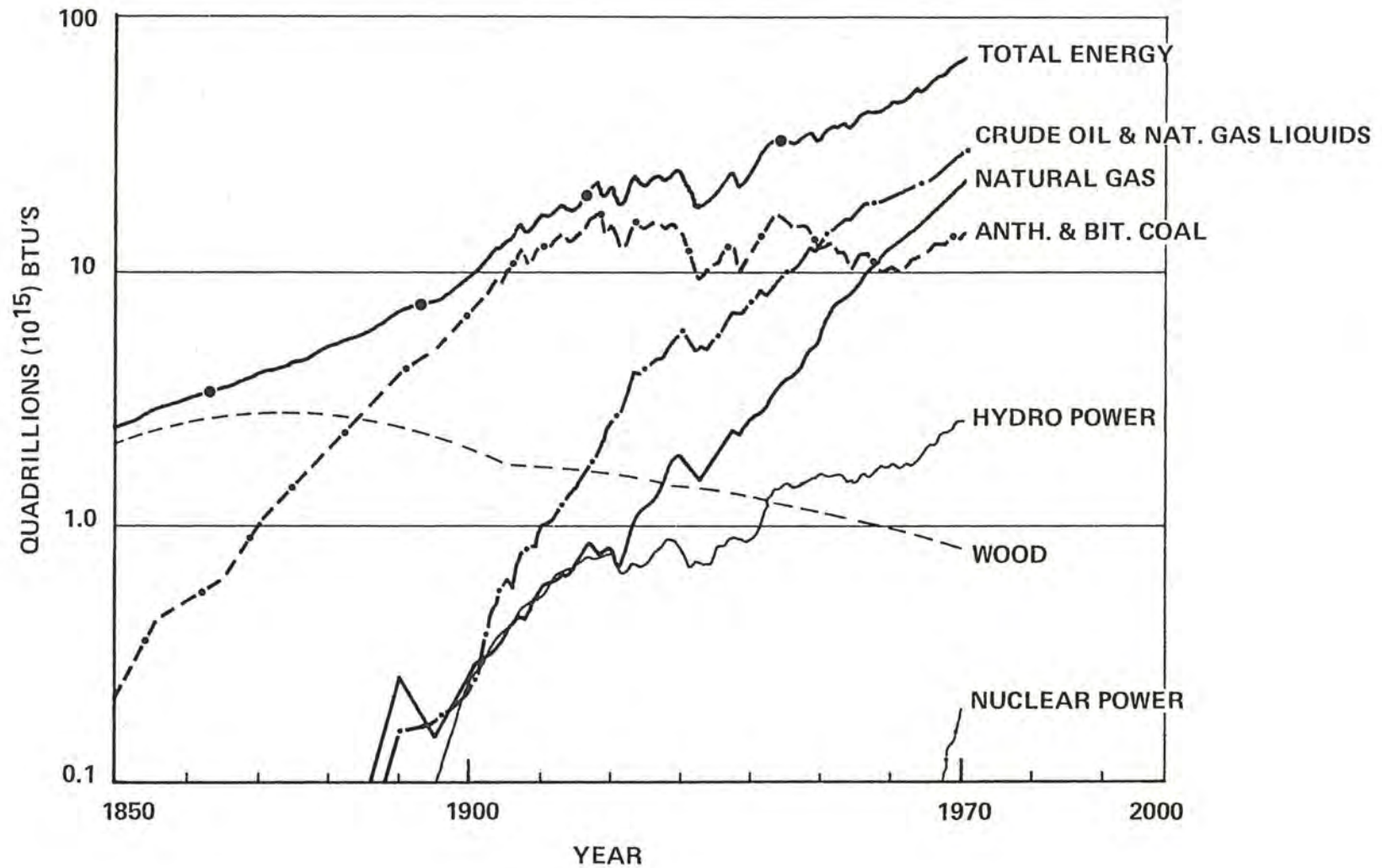

Figure 1. Annual energy consumption in the U.S.A. (ref. 2).

decline. The problem is so acute that the imports of oil amount to 47 percent of the total consumption of petroleum for the last 3 months (ref. 3). Prior to the oil embargo of 1973, our imports were already 30 percent of total consumption. That was over 4 years ago, and the situation is growing steadily worse.

On the other hand, the United States has proven coal reserves estimated to last us as long as 2,000 years. Certainly coal is a much dirtier fuel than petroleum products and represents a significantly worse environmental hazard; but technology is being developed to burn coal in an environmentally acceptable manner.

The relationship between our coal reserves and coal utilization, as compared with petroleum products, is shown in figure 2. The goal of the National Energy Plan to switch from oil to coal is based on the gross imbalance between reserves and production.

## THE SOLUTION--ENERGY CONSERVATION

We cannot afford to sit around and wait for new energy resources to be developed. The only immediate alternative facing us today is that of reducing energy consumption through an effective energy conservation program. The recirculation of industrial exhaust air is only one of several ways of conserving energy consumed in the industrial and commercial sectors of the U.S. economy. In this paper, the focus will be on what makes sense in energy conservation, and on placing in perspective the very many alternatives that energy designers are faced with in trying to develop rational energy conservation strategies.

### Current Usage

The current demand for energy in the United States stands at 74 quadrillion Btu's per year (quads). This is shown broken down into the five consuming sectors in figure 3. Figure 3a shows total gross energy inputs by major consuming sectors for all types of fuels and includes the fuel requirements of electric utilities. More important to industrial energy conservation, however, is the breakdown into the four consuming sectors, as shown in figure 3b. The difference between these two bases is in the energy loss in generation or distribution of electricity.

The energy savings from recirculation of exhaust air can come only from the energy spent for space heating in the industrial and commercial sectors. This is identified in figure 4 based upon the following:

1. Industrial sector--We have estimated the total space heating requirement in the industrial sector to be only 7 percent of the total energy consumption. Hence, the total space heating demand is 1.54 quads.
2. Commercial sector--Almost 60 percent of the energy consumed in the commercial sector, or 2.40 quads, is for space heating.

### Space Heating Target

In space heating applications, energy is lost via the following mechanisms:

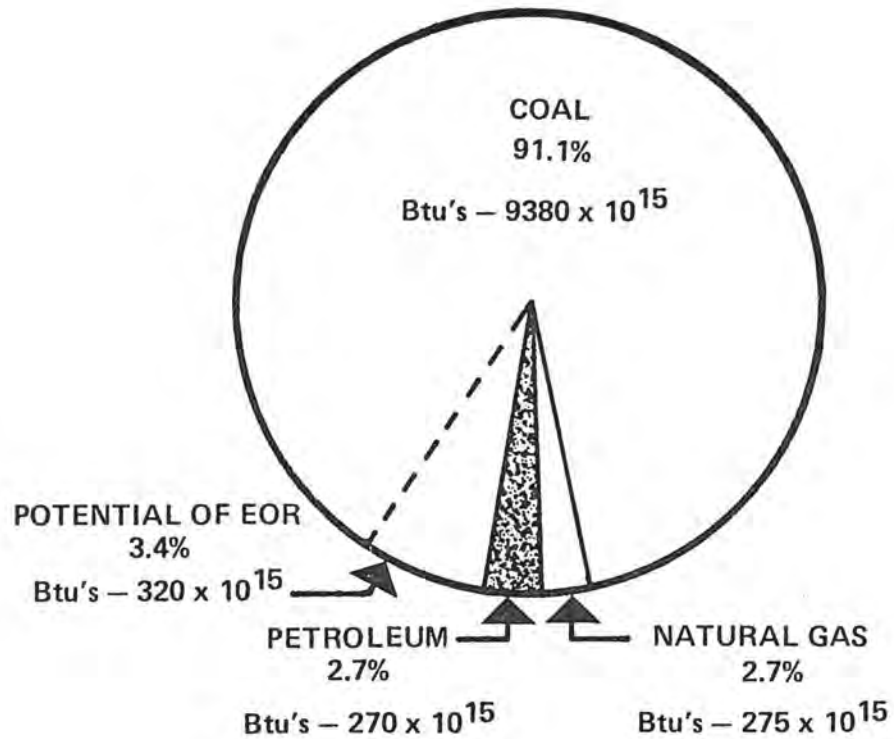

RECOVERABLE U.S. RESERVES

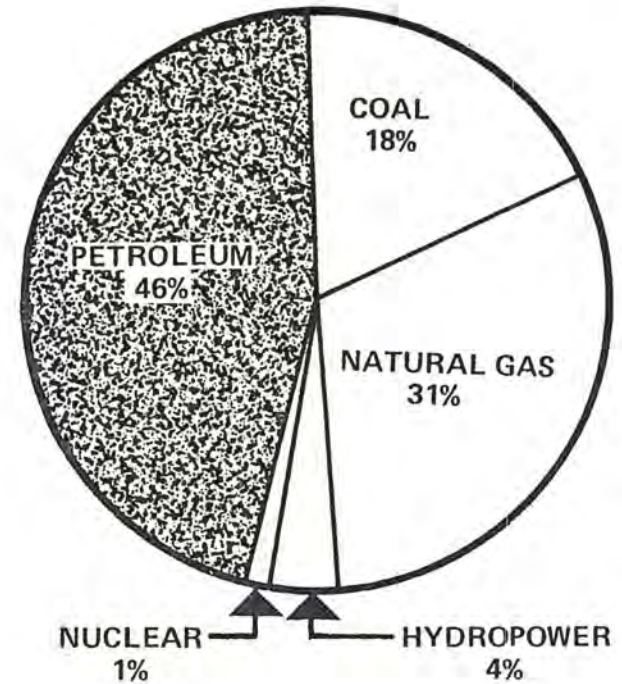
BREAKDOWN OF PRESENT  
U.S. PRODUCTION

EOR = Enhanced Oil Recovery

Figure 2. U.S. reserves and production: The crux of the problem, 1975 (ref. 4).

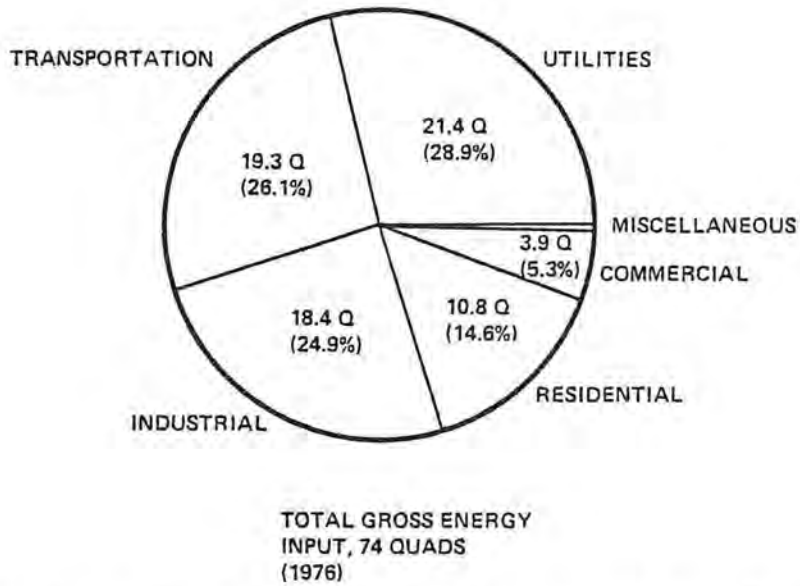

a. Gross energy inputs by major consuming sectors and for all types of fuels.

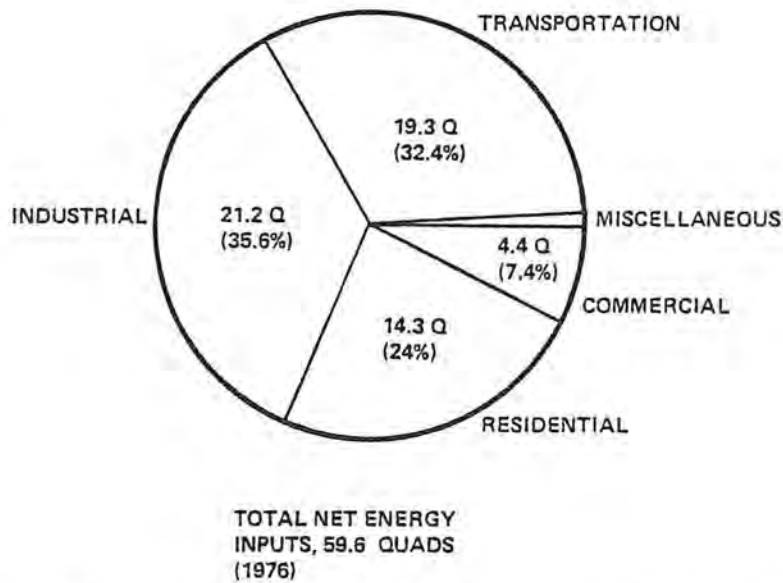

b. Net energy inputs by major consuming sector.

NOTE: The difference between net and gross energy totals consists of conversion losses in the electric sector.

Figure 3. Energy inputs by major consuming sectors (ref. 5).

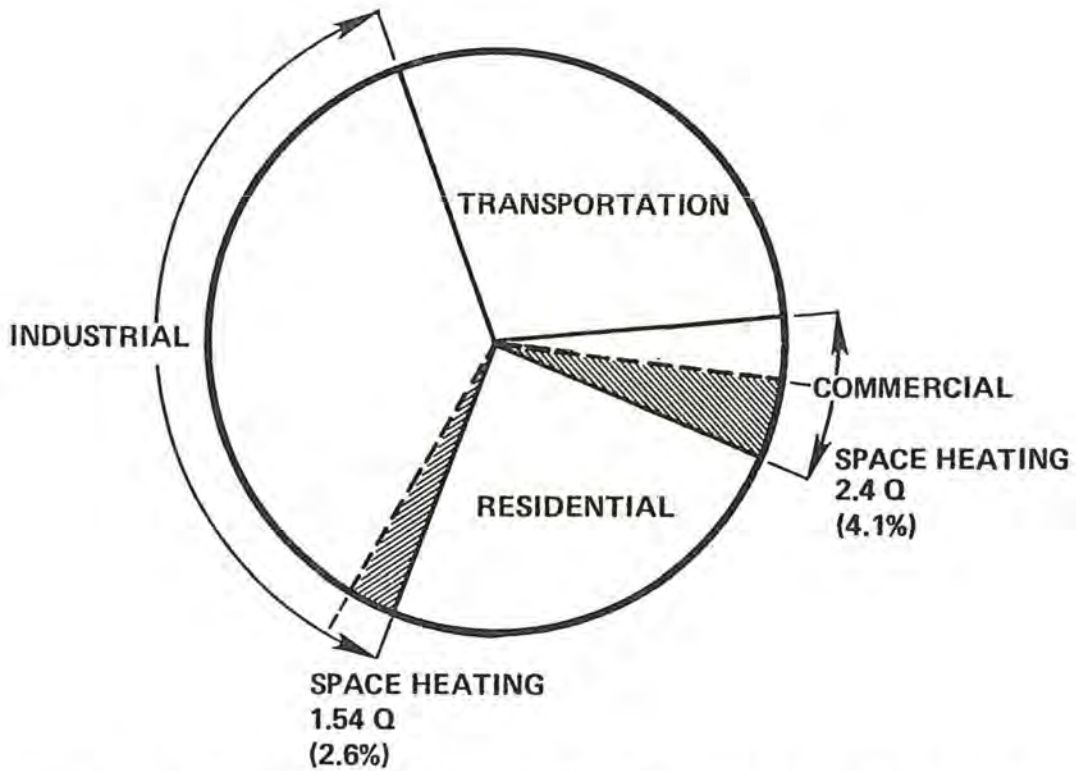

Figure 4. Total net energy inputs (1976) showing fraction used for space heating in the industrial and commercial sectors [5,6,7].

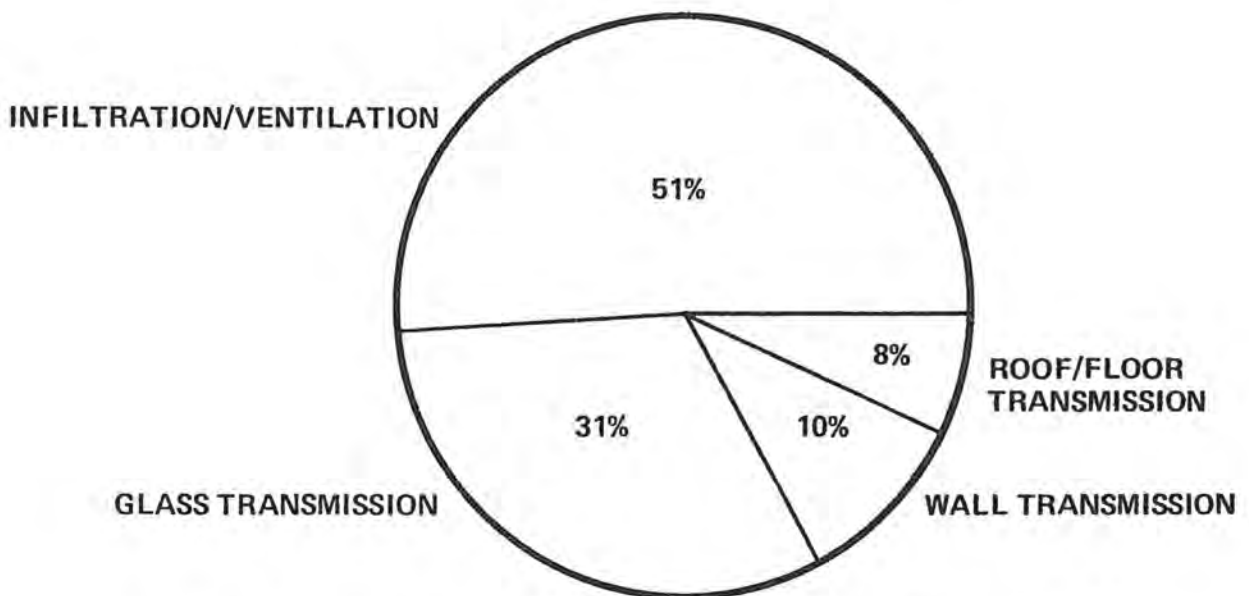

Figure 5. Heat load breakdown for typical 3-story, 400,000 ft<sup>2</sup> office building in typical 5,500° day location [A. D. Little, Inc. estimates, quoted in ref. 7].

1. conduction losses through walls and windows;
2. infiltration losses resulting from the opening and closing of doors, for example; and
3. ventilation losses resulting from fresh-air makeup requirements for buildings.

Calculations based upon the American Society of Heating, Refrigerating, and Airconditioning Engineers (ASHRAE) guidelines for a typical three-story building show that as much as 49 percent of the energy loss occurs by conduction through walls, windows, and doors (ref. 8) (see figure 5). Infiltration from miscellaneous leaks or from opening and closing of doors amounts to another 10 percent of the space heating requirements. Fresh-air makeup accounts for the remaining 39 percent of the space heating requirements.

Note that even at very high recirculation ratios, heat will be required for conduction losses and infiltration losses as well as for a reduced fresh-air makeup. In the author's opinion, it is unlikely that this specific situation will achieve any more than a 30 percent recovery of the space heating requirements. Obviously, the exact amount of energy that could be recovered, either by heat exchange system or by a recirculation system, will vary from situation to situation. As an order of magnitude estimate, we have estimated that approximately 50 percent of the space heating requirements are recoverable.

#### Industrial vs. Commercial

Even though space heating requirements could be fulfilled through recirculation in either an industrial or commercial situation, there are too many sufficient differences between the two environments to expect that major differences in reaction to the recirculation scheme will be experienced. The problem is in assessing the relative degree of difficulty in achieving recirculation as compared to the relative energy benefits to be attained. The industrial and commercial situations are compared in table 1. Note that in a commercial environment, the air is relatively free of hazardous pollutants, suggesting an uncomplicated recirculation system, whereas in an industrial environment (a foundry, for example) the potential for buildup of highly hazardous materials is much greater than in a commercial sector. Likewise,

Table 1. Comparison of commercial and industrial situations.

Factors	Commercial sector	Industrial sector
Contaminants	Minimal	Potential hazard
Space heating requirements	60 percent of total	7 percent of total
Waste heat sources	Few, if any	Several
Exhaust recirculation	Potentially attractive	Limited use

SOURCE: Energy Resources Company (ERCO) assessment.

space heating energy requirements comprise approximately 60 percent of the total energy needs of the commercial environment, whereas they make up only 7 percent of the total energy needs of the industrial environment.

In most cases, the energy designer will consider all the alternatives that he faces for conserving energy. In the case of the commercial environment, the number of alternatives are limited, in many cases, to a trade-off between heat exchange vs. recirculation of industrial exhaust. In the industrial situation, the energy planner can choose from a number of waste heat recovery options from a number of waste heat sources. In most cases, the energy designer will not be limited to air-to-air heat exchange, but in fact will have a number of low-grade heat sources in the plant from which to capture space heat requirements. After all, his space heat requirements are only a small portion of the total energy usage in the plant, and in most cases only a small portion of the total waste heat in the plant. On the basis of this preliminary review, we would conclude that the major target for recirculation technology is in the commercial sector; that in fact the industrial sector will provide very little of its space heat requirements by recirculation of exhaust air.

#### Estimated Net Benefit

Based upon a 50 percent recovery efficiency, the total energy recovery by this technique is slightly in excess of 1 quad or slightly more than 1.5 percent of the energy consumed in the United States. That may not sound like a lot of energy, but is, in fact, equivalent to a half million barrels of oil per day, or approximately one-fourth of the maximum capacity of the Alaska pipeline. Industry has gone to great lengths to build the Alaska pipeline to gain the benefits of the energy there; perhaps industry will also be willing to go to great lengths to reap the benefits of energy conservation techniques such as recirculation of exhaust air.

#### THE PROCEDURE

Up to this point we have discussed energy requirements in the United States in general, and have identified the potential market for industrial exhaust recirculation. We have also suggested, however, that there are several other alternatives that energy planners must consider: heat exchange, recovery from other waste heat sources, and so on. The major questions, then, are: How does one decide? What are the trade-offs between one recovery method and another? Two techniques are vitally important to energy management:

1. energy planning model, which concentrates on energy strategy and focuses primarily on the energy supply situation; and
2. industrial energy activity, which is a tactical recipe for energy conservation focusing on the demand side of the energy equation.

In the paragraphs below, we have described these two down-to-earth methods for assessing the energy supply and energy demand of a given industrial situation. We have also presented a few examples of how these techniques have been put to work in real industrial situations. Together, these two techniques provide a framework from which the energy planner can make rational decisions regarding the recirculation of industrial exhausts by placing them in context with the

many other energy conservation opportunities available to the commercial and the industrial sectors.

### The Energy Planning Model

At the present time there is a great deal of uncertainty regarding energy planning, particularly in the following areas:

1. Fuel availability--Most industries are facing restricted supplies for fuels such as natural gas, propane, and even fuel oil. While coal is available, delays of one or more years are common for obtaining the proper permits and opening new mines.
2. Price fluctuations--The Arab oil embargo has clearly demonstrated that energy has no intrinsic market value, but rather is worth whatever people are willing to pay. Hence, the price for energy several years from now cannot be predicted today with any reasonable accuracy.
3. Several new technologies are being developed, such as fluidized-bed combustion, coal gasification, solar heating, and several others which are in early stages of demonstration or commercialization. These, of course, introduce technical uncertainties into the planning process.

Before energy became a problem, plant designers had very few alternatives to choose from; nor did they need many. Energy was available, it was cheap, and it rarely had a major impact on the cost of the plant outlet. Things have now drastically changed and the energy planner is faced with providing answers for the following questions:

1. What fuel should be used to minimize energy costs without running significant risks of plant shutdown because of restricted supplies?
2. When should old equipment be phased out and new energy-efficient equipment installed?
3. Are large cogeneration-based utility plants more cost-effective than smaller, dispersed equipment, including solar systems, for example?

The energy planner today has literally hundreds of options--most of them not as attractive as options available 10 years ago. To deal with these options, several computer-based programs have been or are currently being developed for energy-use planning at the corporate level. In figure 6, a schematic is shown of one such computer-aided design program having the following components:

1. Input--the program is an interactive program where the engineer tries different plant configurations while on-line with the computer.
2. Executive program--the program handles the actual calculations, optimization, and so on.
3. Data files--these files contain physical/chemical data, descriptions of equipment within the plant, data on material and energy flows, equipment costs, and so on.

Programs such as these have been used historically in the chemical design business for designing a chemical plant. More recently they have been adapted

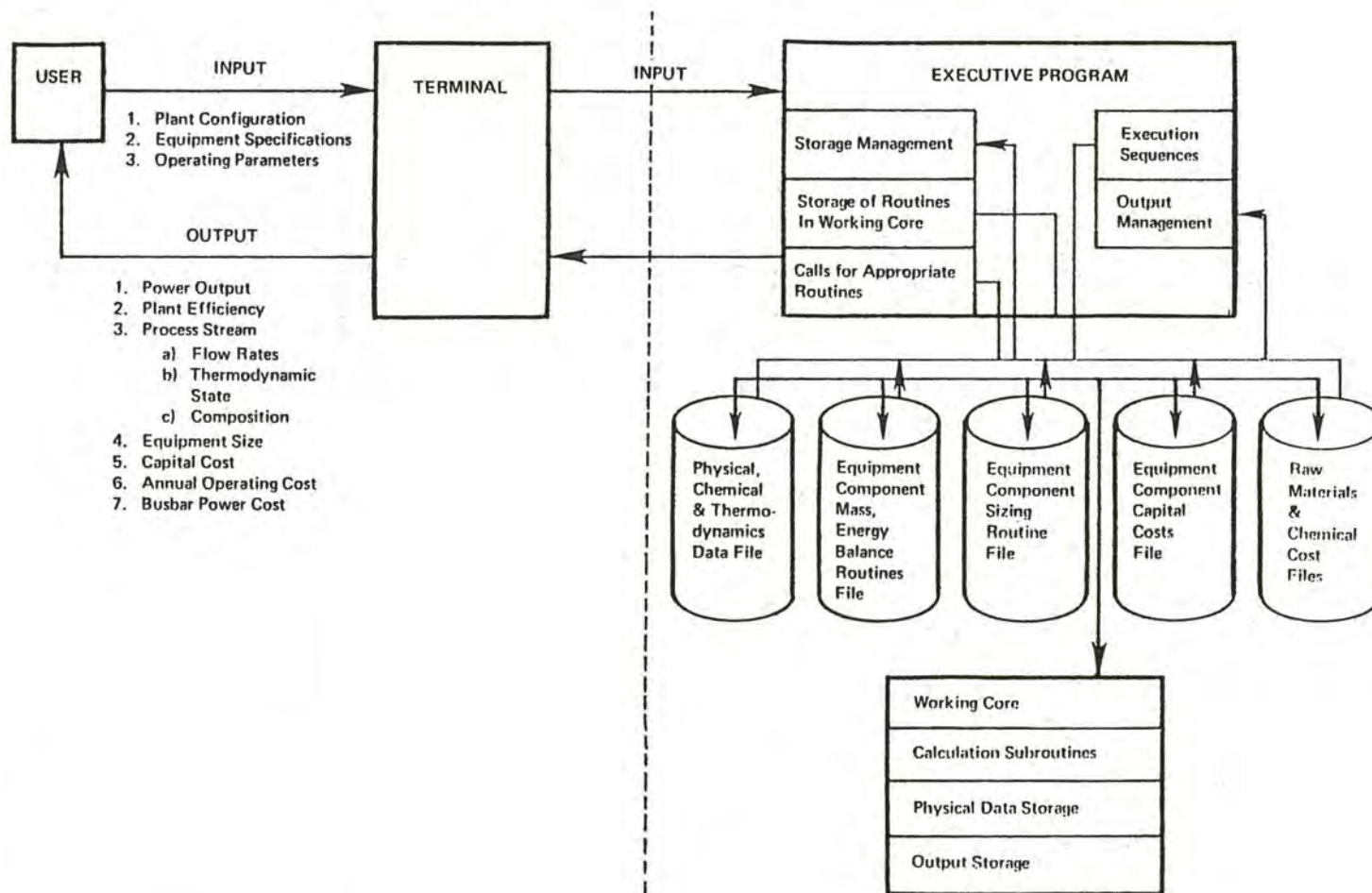

Figure 6. Schematic of computer-aided design.

for providing a cost optimization of energy supply options to suit specific plant situations.

Simplified versions of this type of energy planning model are currently available and in use by a number of companies in the United States, and more advanced, sophisticated versions are currently being developed by industry by EPRI, and within the new Department of Energy.

### The Energy Audit

The demand side of the energy use picture for any industrial situation is much more definable. For the last several years, the technique of industrial energy audits has developed to the point of being a well-developed engineering science. Briefly, this technique traces the energy flow through the plant and determines exactly where energy is spent and where it is lost. Once this is identified, it becomes a matter of straightforward analysis to determine the most cost-effective means for eliminating losses or minimizing them. The steps in an industrial energy audit are detailed in the following paragraphs.

#### Plant Survey--

The first step in an energy audit is to conduct a detailed plant survey to determine the flow of energy for each individual building or industrial operation within a plant. As an example, consider an audit recently conducted for a textile manufacturer using a batch system for dyeing a product. The dye operation has three steps--scouring, dyeing, and rinsing. The temperature of the system and the corresponding energy requirements, either for heatup or for holding at temperature, are shown in figure 7. Similar data are developed for each major energy-consuming operation within the plant.

#### Establish Par Values--

Apart from understanding what each process in a plant consumes in the way of energy, it is also important to establish a par value, i.e., the amount of energy that a reasonably energy-efficient process should be using. As an analogy, consider a golfer who measures his efficiency at the game according to the number of strokes he takes above or below par. The par for each hole is set up according to the number of strokes required by a proficient golfer, if he makes no mistakes and does not rely on luck. The same type of scale can be constructed for each operation in a plant. Note that these are not theoretical limits, but are limits that could be obtained under normal practice.

#### Determine Total Energy Use Patterns--

Once the energy usage and par value for each process in the plant have been determined, then it is possible to simulate the energy flow for the entire plant. For example, the textile mill described previously has an energy flow shown in the Sankey diagram in figure 8. The plant uses both natural gas and fuel oil shown on the left. The fuel oil is used entirely for steam generation while the gas is used both for steam generation and for direct-fired heaters. The plant has several sources of heat loss, as shown across the top of the diagram. The plant achieves a modest amount of waste-heat recovery in the form of heat exchange with hot water, and condensate returned to the boiler. Major losses occur from the fact that the Becks are open to the atmosphere at near-boiling temperature, and therefore considerable heat is lost due to evaporation. Second, a large amount of hot water is literally

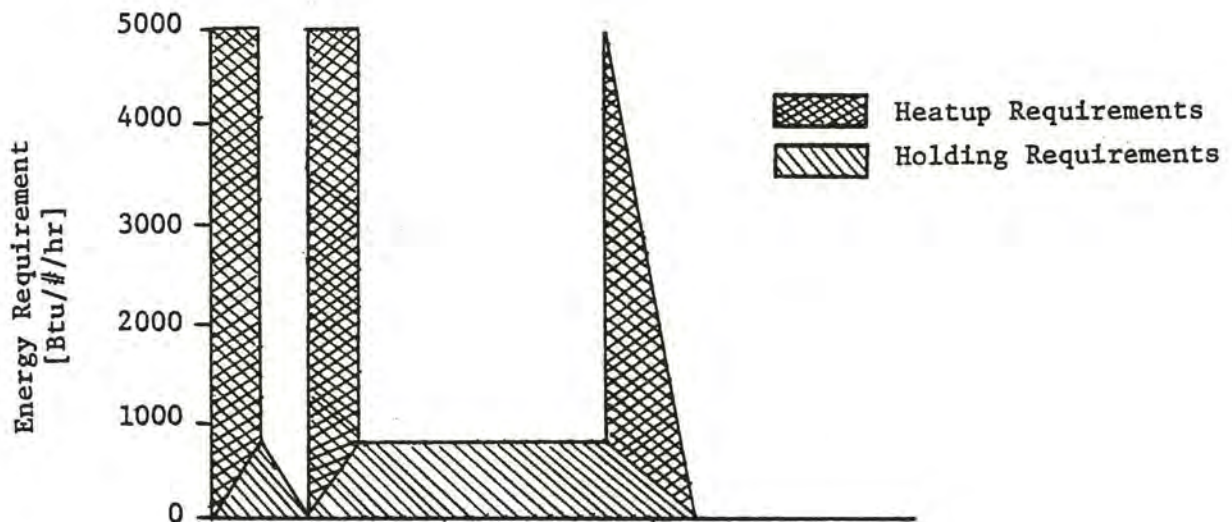
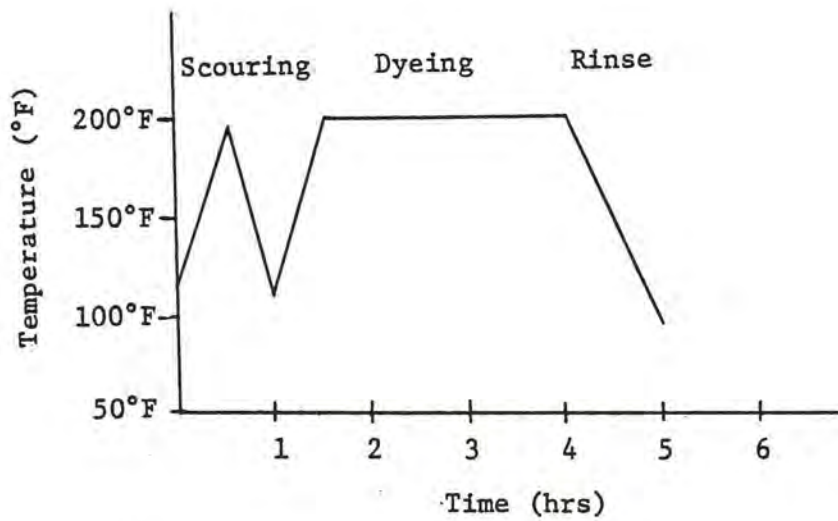

Figure 7. Energy requirements for typical open Beck cycle.

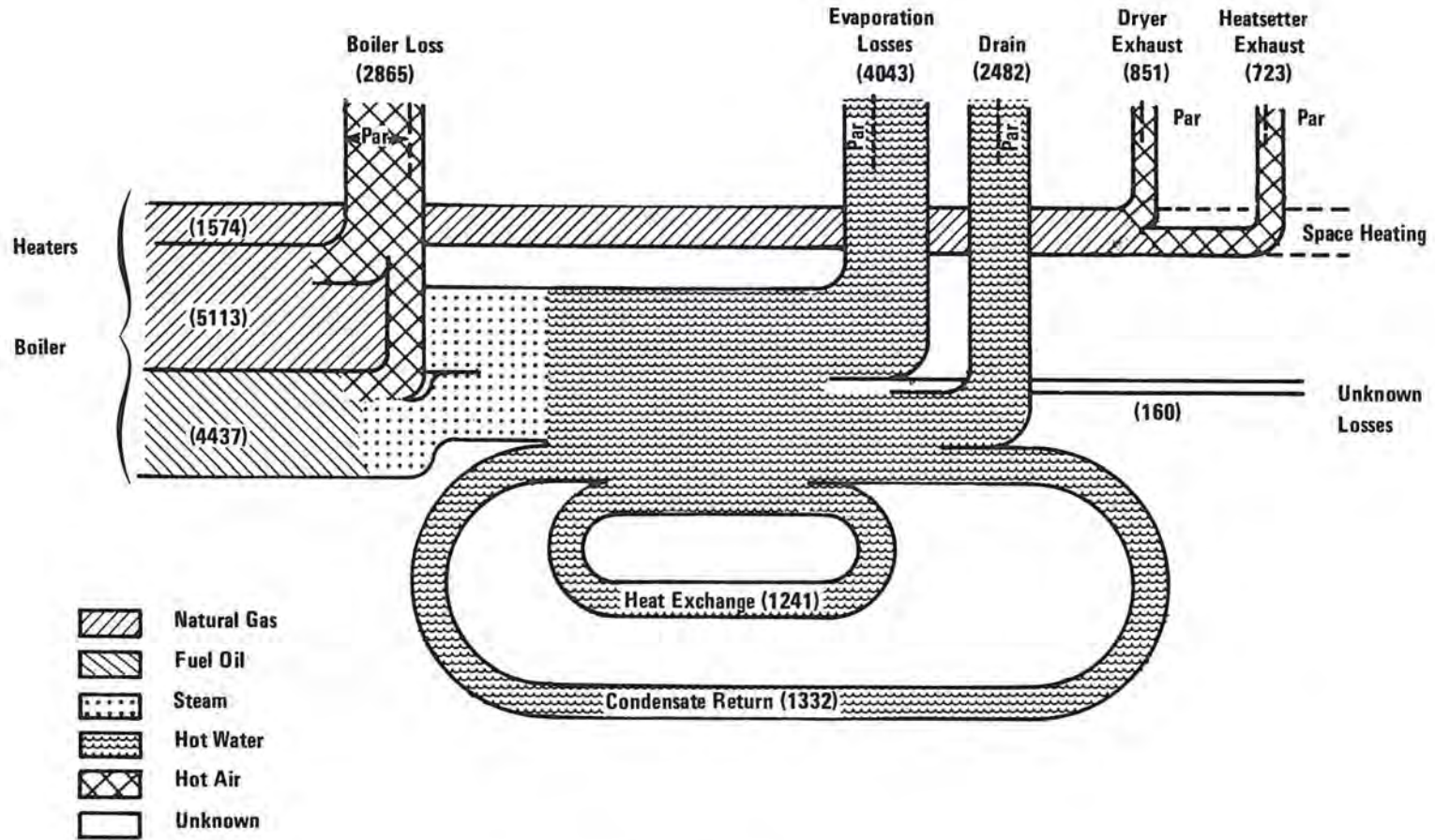

Figure 8. Example energy audit.

down the drain. Finally, note that the space heating requirements on the far right are supplied entirely by exhausting the fabric dryers and heat setters into the building. This is not the most effective system from an occupational safety point of view, but it does show that space heating requirements are much less than the total energy requirements of the plant, and that the amount of waste heat available at the plant is indeed greater than the amount required for providing 100 percent of the space heating requirements.

#### Evaluate Conservation Alternatives--

Experience in the process industries has shown that the first 10 to 15 percent in energy savings comes fairly easily through minor changes throughout the plant. As the company reaches this point, even more sophisticated ideas will be proposed for eliminating unnecessary fuel uses or increasing process efficiencies. The ideas for energy conservation fall into the following three categories:

1. Waste savers--Waste-saving ideas include relatively low capital expenditure projects aimed at specific waste streams. In practically every establishment, there will be a variety of things that can be done that could improve the energy utilization of various operations. These include additional maintenance, added insulation, and so forth.
2. Capital projects--Capital projects are those that could result in significant energy savings but will require significant investments as well. These types of projects include greater utilization of heat exchangers, more efficient use of steam power, recirculation of exhaust air, and the like.
3. Process modifications--The area in which the most significant energy savings can be accomplished in the long term is in major process modifications. Major process changes can take two forms: (1) adding or replacing equipment that increases the flow of production through the plant or reduces costs; and (2) replacing old process schemes with innovative technology.

With each of the types of conservation projects described above, the energy planner must evaluate the cost and energy savings for the technology and choose those mixes of technology that are most cost-effective.

As a result of the steps outlined above, an energy planner will be able to determine where the energy is coming from, where it is going, and what the most effective means are for reducing energy losses. Certainly, in carrying out this procedure, the recirculation of industrial exhaust will be one of the methods considered in step 3. As can be seen from the examples, the opportunities for recirculation of industrial exhaust are more likely to occur in the commercial sector where less competition with other techniques is expected.

#### ENERGY MANAGEMENT IS A FULL-TIME JOB

It is not enough to study the energy situation of a given plant or even enough to figure out what the most cost-effective means are for achieving conservation. Energy conservation must be a corporate endeavor that is given a high priority from the company's top management. Support for an energy conser-

vation program includes both manpower and money necessary to carry out energy savings ideas.

The objectives of an energy conservation program are to:

1. set reasonable goals for energy consumption at each plant;
2. monitor and report energy utilization in each plant; and
3. promote communication on energy conservation both vertically and horizontally within the company.

The idea of goal-setting is an important one because it establishes a reference from which to measure progress in energy conservation. The key step in the energy conservation program is to continuously monitor the energy usage at each plant and compare this usage with target values determined during the energy audit. The monitoring should be accomplished by plant operating personnel for two major reasons. First of all, this type of monitoring program increases the operator's awareness of energy waste within the process, and secondly, it allows a company to capitalize on the operator's know-how in being able to improve process efficiencies. In fact, experience in the process industries has shown that one of the most valuable sources of waste-saving ideas is the operating personnel.

Finally, interplant communication is extremely important to an energy conservation program because it maintains a constant awareness of the need for energy conservation throughout the company. Each plant should report its energy consumption monthly as compared to the target of consumption for that plant. A corporate energy coordinator should review these reports and transmit them directly to top management. At the same time, coordinators should develop a means of communications through a newsletter in order to keep all the company informed of the progress in energy conservation, and also to encourage the exchange of technical information between plants. This type of program has proven to be very effective in both process and manufacturing industries in that it provides a forum for explaining various energy-saving techniques used in different plants.

#### IMPACT OF INDUSTRIAL EXHAUST RECIRCULATION

Over the next several years, particularly in light of the National Energy Plan, energy conservation will become an increasingly more important topic. A new surge in energy planning will come about comparable to the surge experienced shortly after the oil embargo of 1973. It is during the course of this new emphasis and new evaluation work at the plant level that the worth of recirculation of industrial exhausts will be borne out. From the present perspective, however, it is clear that:

1. recirculation can indeed effect significant savings in energy in the coming years;
2. the technique can be quickly implemented on both the industrial and commercial scale; and
3. as a part of a systematic analysis of energy conservation opportunities, recirculation is a welcome addition to the portfolio of techniques currently considered by energy planners across the nation.

## REFERENCES

1. National Energy Plan, Executive Office of the President, Energy Policy and Planning Division, Washington, D.C., U.S. GPO No. 040/000/00380/1, April 1977.
2. H. C. Hottel and J. B. Howard, New Energy Technology, Cambridge, Massachusetts: The MIT Press, 1971, p.4.
3. U. S. Department of the Interior, Bureau of Mines, "Minerals and Materials: A Monthly Survey," Washington, D.C., August 1977.
4. Mining Engineering, May 1975, p. 29.
5. Bureau of National Affairs, Energy Users Report, Washington, D.C., 1977, p. 41.
6. U. S. Energy Research and Development Administration, A National Plan for Energy Research, Development and Demonstration, 77-1.
7. Federal Energy Administration, Project Independence, Vol. 1, November, 1974, p. 127.
8. ASHRAE "Handbook of Fundamentals," New York, 1972, pp. 375-389.

## DISCUSSION

MR. ROBERT POTOKAR (General Motors, Warren, Michigan): I wonder where you got your 7 percent energy, industrial heat?

DR. STEPHENS: The 7 percent is an informal estimate attributed to Westinghouse.\* The space heating requirement in the commercial sector is reasonably well-defined, but the data for the industrial sector is not broken down by end-use and therefore the space heating requirement is not readily available.

Mr. Potokar: Exxon is involved with a survey, and I believe the figure is going to be closer to 20 percent.

---

\*Personal communication from Mr. Michael Glesk, Arthur D. Little, Inc., Cambridge, Mass., September 1977.

## UTILIZATION OF AIR CLEANING EQUIPMENT IN EXHAUST AIR RECIRCULATION SYSTEMS

John T. Talty, P.E.\*

### Abstract

*The energy crisis is providing an incentive for industry in the United States to conserve fuel. A major consideration is the recirculation of industrial exhaust air to reduce energy consumption in heating or cooling workplace air. Air cleaning equipment is an essential component of recirculation systems that must be designed to prevent occupational health problems.*

*Although there is a history of literature on the subject, meaningful design criteria for recirculation systems are very limited. Primary system components are air cleaning equipment and monitoring/alarm equipment. Monitoring equipment requires significant development work in order to assist in safeguarding recirculation systems.*

*It is very important to evaluate each case on its merits to determine the feasibility of recirculation. If feasibility is established, air cleaning equipment must be selected to properly remove specific contaminants. Air cleaning equipment (ACE) is normally designed for the removal of particulates or gases and vapors. The following ACE is considered to have potential for recirculation system design:*

- 1. absorbers/wet collectors,*
- 2. adsorbers,*
- 3. electrostatic precipitators (ESP), and*
- 4. fabric filters.*

*Each of these types of equipment is reviewed from the standpoint of collection mechanism, equipment configuration, performance capability, and applicability to recirculation. Cost data from 1969 for particulate collectors are also summarized.*

*A general approach to design of ACE is presented with the following major factors requiring in-depth study as part of the design process:*

- 1. characterization of air stream and contaminants,*
- 2. collection required,*
- 3. equipment capability,*
- 4. residue disposal,*

---

\*Chief, Control Technology Research Branch, DPSE, NIOSH, Cincinnati, Ohio.

5. costs, and
6. operation and maintenance requirements.

*Options must be evaluated to arrive at a specific design approach. Current studies to improve design criteria for recirculation systems are discussed.*

*Research needs are discussed relating to the following subjects:*

1. ACE performance in recirculation systems,
2. ESP,
3. fabric filtration, and
4. wet scrubbing.

*Conclusions are presented concerning the use of commercial air cleaning equipment and an engineering design approach for recirculation systems.*

## INTRODUCTION

The energy crisis that has developed in the United States is a major problem facing both the public and private sectors of our nation. As we search for solutions to the problem it is evident that two approaches are necessary-- conserve usage and increase the supply of energy resources. As industry searches for methods to conserve the use of energy resources, increasing attention is being given to the concept of recirculating exhaust air so as to conserve the use of energy in heating or cooling air used in the workplace.

In order to prevent the development of major occupational health problems as a result of recirculating air, it is obvious that air cleaning equipment will be a necessary component of systems designed for this purpose.

The purpose of this paper is to review the concept of air recirculation, the applicability of air cleaning equipment (ACE), and design approaches that are appropriate. A discussion of ACE research needs will also be presented. Finally, an attempt will be made to put available information in perspective and to identify certain conclusions reached.

## RECIRCULATION OF EXHAUST AIR

The general concept of industrial air recirculation has been briefly discussed in the literature for many years. A literature search on the subject using the "Compendex," "Pollution," and "Bert" (NIOSH) data bases was performed resulting in 119 citations of which 7 were relevant. The earliest reference found dates back to 1952, which included a specific discussion of the "Recirculation of Cleaned Air from Dust Collectors" (ref. 1). Additional literature considered significant to the subject is identified in references 2, 3, 4, and 5. Although literature does exist on the subject, actual documented industrial experience is very limited, and technical design criteria for recirculation systems have not been developed in sufficient detail.

It should be made clear that the applicability of air recirculation is limited in consideration to air that would otherwise be discharged through an exhaust system to the atmosphere from a ventilation system. An exhaust system is

defined to include hoods, ducts, fans, air cleaners, and necessary monitoring equipment. The concept is not intended to apply to industrial process air, from a furnace for example, which would normally be discharged to the atmosphere through a stack. The basic concept is to return cleaned air to the workplace to reduce the use of energy to heat or cool makeup air. The recirculated air must not produce excessive contamination of the workplace. Established occupational health standards for contaminants provide minimum design criteria that a recirculation system must be able to achieve (ref. 6).

The primary control equipment that must be designed as integral components of a recirculation system are suitable air cleaner and monitoring/alarm equipment. Air cleaners, the primary subject of this report, are discussed in detail in the following sections of this paper.

The basic purposes of contaminant monitoring in a recirculation system are to provide documentation of contaminant levels at specific points in the system and to trigger an alarm mechanism and remedial action if system failure occurs. Failure is defined as discharge of recirculated air to the workplace, which would result in worker exposure to contaminants at levels that exceed Occupational Safety and Health Administration (OSHA) standards. Monitoring equipment capability is considered to be a weak link in the technology for recirculation systems requiring significant development work (ref. 7).

#### AIR CLEANING EQUIPMENT

This discussion of air cleaning equipment (ACE) will cover the types of contaminants that are considered recirculatable and that require removal, the basic types of cleaning equipment, the expected performance and limitations of cleaning equipment, and cost data. The discussion will be focused on use of ACE for primary collection of contaminants, recognizing that precleaning and postcleaning may also be necessary for specific systems.

A basic premise that should underly consideration of the utilization of ACE in recirculation systems is that only those substances for which safe air quality levels have been established or that are known with confidence to be nonhazardous to workers health should be considered recirculatable. In the context of this paper, a safe level is equivalent to an OSHA standard air concentration for particular contaminants or mixtures (ref. 6). A review of 541 single substances has been performed by Southwest Research Institute and it was concluded that 158 contaminants should not be considered for recirculation (ref. 8). The specific criteria for exclusion are quite complex and are presented in the referenced report. The point of this information is that considerable discretion must be used in making a judgment as to whether recirculation should be considered in a particular plant, in advance of attempting to select ACE capable of removing specific contaminants. Once this judgment to recirculate has been made, it is then essential to select or search for ACE that is capable of sufficient contaminant removal.

Air contaminants may be classified as gases and vapors or particulates and may occur singly or in mixtures. This classification also provides a useful basis for discussion of the basic types of ACE available.

Table 1. Major types of ACE in use in industry.

Types of cleaning equipment	Primary contaminant collected	
	Gases and Vapors	Particulates
Absorbers	X	-
Adsorbers	X	-
Incinerators	X	-
Electrostatic precipitators	-	X
Fabric filters	-	X
Mechanical collectors	-	X
Wet collectors	-	X

It is also true that gases and vapors may also be combined with particulates in a particular exhaust airstream and the overall cleaning problem increases in complexity. Recognizing the potential complexities, the basic types of ACE will now be discussed including a description of the capability associated with each. Combinations of ACE in a particular plant may indeed be necessary to properly cope with the airstream contaminants of concern.

As shown in table 1, ACE includes seven basic types of equipment. Although incineration is an effective mechanism for oxidation of organic gases and most odorous materials, the equipment cost and large fuel requirements eliminate it as a realistic technique for recirculation for energy conservation (ref. 9). Mechanical collectors have very poor collection efficiency for smaller particles and are also not considered applicable to recirculation systems (ref. 9). Seven sources were used as basic references in developing the following discussion of equipment that does have potential application to recirculation system design (refs. 10, 11, 12, 13, 14, 15, and 16).

It should be noted that there is a wide variety of ACE that is commercially available. Based on a 1977 Product Guide review (ref. 17) the information in table 2 was obtained to place the subject in perspective.

#### Gas and Vapor Collection

##### Absorbers--

Gas absorption is a mechanism by which constituents are removed from a gas stream by dissolving them in a selective liquid solvent. Absorption equipment is designed to provide thorough contact between the gas and liquid solvent, to allow interphase diffusion of materials. The contact can be achieved by dispersing gas in a liquid solvent or liquid solvent in a gas. Absorbers that use liquid dispersion include packed towers, spray towers or spray chambers,

Table 2. Emission control equipment.

Type	Item having largest no. of manufacturers	No. of manufacturers-
Inertial separators	Cyclone separators	65
Scrubbers and washers	Mechanical scrubbers	64
Fabric and filter collectors	Complete baghouses	65
Other equipment	Direct flame fume incinerator	56
Fans and blowers	-	40

and venturi absorbers. Equipment that uses gas dispersion includes plate towers and vessels with sparging equipment.

Packed towers are commonly filled with plastic shapes which, when wetted by the solvent, present a large area of liquid film for gas contact. Usual flow conditions are countercurrent with the liquid introduced at the bottom flowing upward. This equipment is usually preferred for smaller installations with the preferred tower diameter less than 2 ft.

Spray towers and chambers achieve interphase contact by dispensing the solvent as a spray and passing the gas through it. This equipment is preferred when pressure drop is a major concern and where solid particles exist in the gas stream.

Venturi absorbers achieve interphase contact by means of the differences between the gas velocity and liquid velocity, and the turbulence in the throat. This equipment obtains good liquid-gas mixing but has the disadvantage of short contact time and high pressure drop.

In contrast to packed towers, plate towers employ stepwise contact by means of a number of plates arranged so the gas is dispersed through a liquid layer on each plate. Plate towers are usually selected in larger sizes and where the solvent liquid contains suspended solids that tend to plug packed towers.

A simple method of dispersing gas in a liquid is by injection of the gas through a perforated pipe into a vessel filled with the solvent liquid. This is sparging.

In general, absorber removal efficiencies would require upgrading to achieve acceptable in-plant air quality levels. Exit air from absorbers is close to saturation and would also present a potential water vapor problem in the plant. Absorbers would have limited application in recirculation system design.

## Adsorbers--

Gas adsorption is the phenomenon by which molecules of a fluid contact and adhere to the surface of a solid material. By this process, gases at very small concentrations can be selectively removed from airstreams by specific materials called adsorbents. The constituent adsorbed is called the adsorbate. The most important characteristics of adsorbents are their large surface-to-volume ratios and preferential affinity for individual constituents. The adsorptive power of any adsorbent may vary significantly with the method by which it is prepared as well as the nature of the gas or vapor adsorbed. In most adsorption processes, three steps are involved. First, the adsorbent is contacted with the fluid, and a separation by adsorption results. Second, the unadsorbed portion of the fluid is separated from the adsorbent. Third, the adsorbate is removed from the adsorbent, which thereby regenerates the adsorbent.

Solids possessing good adsorptive properties are numerous. Activated carbon, silica gel, alumina, bauxite, and molecular sieves are some of the widely used adsorbents for gas cleaning.

Adsorption systems are generally of the cyclic, fixed-bed type or the fluidized- and moving-bed type. Most systems are of the fixed-bed design based on a permissible airflow rate and breakthrough of the adsorption zone. The pressure drop in fixed-bed units is higher than fluidized units due to the gas flow through the entire bed, rather than just the adsorption zone. Fixed-bed design requires prediction of the length of adsorption and the desorption cycle. Fluidized beds operate by countercurrent contact of gas and solids. They offer the advantage that for a given pressure drop and cross-sectional area, high gas rates may be used.

Since adsorption efficiency is reduced as retention capacity is approached, monitoring to identify breakthrough is essential in adsorption systems that would be used in recirculation systems. Also, the presence of particulates in the gas stream contaminates adsorbent materials and would necessitate frequent regeneration of the adsorbent. Adsorbents should have wide application in recirculation system design as primary equipment for the collection of gases and vapors.

## Particulate Collection

### Electrostatic Precipitators--

Electrostatic precipitation (ESP) is a process which utilizes forces on electrically charged particles in the presence of an electric field to effect the separation of particles from a gas stream. The principal functions of the process are as follows:

1. generation of corona,
2. particle charging,
3. particle collection, and
4. particle removal.

Corona is a gas discharge phenomenon associated with the ionization of gas molecules by electron collision in regions of high electric field strength. The process requires a nonuniform electric field which is obtained by the use of a small diameter wire as one electrode and a plate or cylinder as the other

electrode. The corona is positive if the wire electrode is positive, and negative if the wire electrode is negative. Negative corona permits operation at higher voltage and is used for most industrial applications.

Recent literature has reported results of laboratory studies that indicate that both ozone and oxides of nitrogen may be produced in the corona discharge of ESP (refs. 18 and 19). Both contaminants are hazardous to health at low concentrations and must be considered a disadvantage in considering the applicability of ESP in air recirculation systems. The following design procedures have been identified to minimize the production of contaminants in an air atmosphere:

1. use a positive corona,
2. select a corona wire of the smallest possible diameter, and
3. heat the corona wire.

The forces acting on a charged particle in a precipitator are gravitational, inertial, electrical, and aerodynamic. The latter two are the principal collection forces in ESP. The collection of a particle depends upon the probability that it will enter the region where the electrical force will result in its deposition on the collection surface. Gas flow is generally turbulent in ESP and this flow determines the trajectory of dust particles in the interelectrode region. The particle velocity due to electrical force is significant only in the region adjacent to the collection electrode. The following equation expresses the theoretical collection efficiency in ESP (ref. 13):

$$\eta = 1 - \exp - \frac{A}{Q} w \quad (1)$$

where  $\eta$  is the efficiency,  $A$  is the collection surface area,  $Q$  is the gas flow rate, and  $w$  is the precipitation rate parameter or effective migration velocity of a particle. In order to obtain an overall collection efficiency, an integration of the above equation for the specific dust particle size distribution range would be necessary.

Once collected at the electrode, the particles must be removed from the ESP. This can be accomplished by means of a liquid flowing down the electrode to wash down the particles or by rapping the electrodes to dislodge the particles. The advantages of wet removal are the minimization of dust reentrainment and elimination of dust resistivity. Some wet removal problems include corrosion, scaling, and slurry disposal. The principal problem with dry removal methods, rapping, is dust reentrainment. Rapping frequency and intensity require close attention in order to minimize reentrainment.

Dust resistivity is one of the major factors limiting ESP performance. If the collected dust is of high resistivity, the current density will be limited by breakdown of the interstitial gases in the dust layer. The two principal methods of overcoming dust resistivity problems are by means of operation at temperatures that will produce a desirable resistivity and the addition of chemical conditioning agents to the gas. The low temperatures prevalent in most exhaust systems should present minimal dust resistivity problems.

The design of ESP equipment is normally based on collection efficiencies ranging from 90 to 99 percent, including small particles. Design is based on equation (1) with the precipitation rate parameter,  $w$ , being the most important consideration. In practice, the selection of  $w$  is made taking into account reentrainment, uniformity of gas flow, electrical sectionalization, and other factors. ESP with positive corona may have applicability to recirculation system design.

#### Fabric Filters--

Fabric filters capture and retain particles by means of simple sieving for large particles, and by means of inertial impaction, diffusion, gravitational settling, and electrostatic attraction. Once a mat or cake of dust particles is accumulated, additional small particle collection is achieved by sieving, as well as by the above mechanisms. Fabric filters are made of woven or felted textile materials in the shape of a cylindrical tubular bag or flat, supported envelope bag. Some commonly used fabrics are cotton, wool, nylon, acrylics, and glass. The filter material is retained in a metal housing with inlet and outlet gas connections, dust storage hopper, and a mechanism for periodic cleaning of the fabric.

The operation cycle of the fabric filter includes two phases. The first is the filtration phase when particles are being deposited and accumulate on the fabric as the pressure drop across the dust deposit increases and airflow decreases. The second phase is the cleaning operation for dust removal with no filtration flow. The two phases also serve as a basis for classification of filters with regard to filtration and cleaning mechanisms.

Both tubular and envelope filter elements are usually installed vertically, allowing dust to fall to a collection point for disposal. Gas is usually introduced at the bottom of a compartment with upward flow. Another major variable is whether the dust will collect on the inside or outside of the filter element.

The cleaning process may be manual or automatic. The most common cleaning methods are by shaking or reversing the flow through the filter cloth. Shaking methods include the following:

1. horizontal or vertical shaking of one end or all of the filter element,
2. vibrating or rapping,
3. fluttering with air currents,
4. snapping with a compressed air pulse, and
5. sonic cleaning.

Flow reversal methods include the following:

1. forcing the cake off by back pressure,
2. collapsing the cloth resulting in flexure and cracking of the cake,
3. snapping with a compressed air pulse, and
4. blowing the cake off with a jet of air.

Although filtration theory has been developed in depth, it is difficult to relate collection efficiency and pressure drop to the actual operation of

fabric filters. Most industrial design is therefore based on past experience and industry practice. The primary design parameters are as follows:

1. air-to-cloth ratio (airflow/cloth area) or filtering velocity,
2. fabric and dust resistance,
3. selection of fabric material, and
4. selection of cleaning method.

Basic equations are available to estimate resistance, or pressure drop. The total pressure drop is the sum of the basic fabric resistance plus the dust resistance. The following equations express this relationship (ref. 10):

$$\Delta P_f = K_f \times V_f, \quad (2)$$

$$\Delta P_d = K_d \times V_f \times C_d, \text{ and} \quad (3)$$

$$\Delta P_{\text{total}} = \Delta P_f + \Delta P_d \quad (4)$$

where

$\Delta P_f$  = fabric/residual dust resistance, in. of H<sub>2</sub>O

$K_f$  = fabric resistance factor, in. of H<sub>2</sub>O/ft/min

$V_f$  = filtering velocity, ft/min

$\Delta P_d$  = dust cake resistance, in. of H<sub>2</sub>O

$K_d$  = dust resistance coefficient, in. of H<sub>2</sub>O/ft/min/grains/ft<sup>3</sup>.

$C_d$  = dust loading, grains/ft<sup>3</sup>.

Fabric filters provide very high collection efficiencies, exceeding 99 percent, including small particles, with pressure drops of 4 to 6 in. of H<sub>2</sub>O. Some potential disadvantages of filters are that liquids can cause failure and some dusts can present a fabric fire or explosion hazard. Fabric filters are considered to have extensive applicability to the design of recirculation systems.

It should be noted that fiber filters, commonly used in air conditioning systems, may also have application for small installations with very light dust loadings.

#### Wet Collectors--

Wet collection is accomplished by the mechanisms of inertial impaction, impingement or interception, diffusion, thermal gradients, and electrostatic attraction. Particle wetting characteristics, condensation of moisture, and liquid evaporation also have an impact on collection of particles. Generally, inertial impaction and interception are the predominant mechanisms for particle collection in wet collectors. Inertial impaction occurs when a particle in the gas approaching a droplet separates from the path of its gas streamline around the droplet and continues on to collide with the droplet. When a particle follows the path of the streamline around the droplet, and a streamline

carrying a particle passes within  $d_p/2$  from the droplet surface, where  $d_p$  = the particle diameter, interception occurs.

There are some 15 categories of wet collectors or scrubbers and from 20 to 30 design variations in each category. Wet collectors may be broadly classified as low- or high-energy scrubbers. Low-energy scrubbers with 1- to 6-in. water gauge pressure drop include simple spray towers, packed towers, and impingement plate towers. High-energy scrubbers with pressure drops of 10 to 35 in. water gauge include the venturi type. Scrubbers may also be categorized on the basis of principle of operation as follows:

1. gravity spray,
2. centrifugal or wet cyclone,
3. self-induced spray,
4. impingement plate,
5. packed bed.
6. venturi, and
7. mechanically induced spray.

Discussion of the details of each of these types of equipment is beyond the scope of this paper but may be found in other sources (refs. 11 and 14).

The following equation expresses the collection efficiency for wet scrubbers (ref. 11):

$$\eta = 1 - \exp(-N_t) \quad (5)$$

where  $\eta$  is the efficiency and  $N_t$  is the dimensionless transfer unit that describes the gas-liquid contacting power. Equations to determine the value of  $N_t$  have been developed for various types of wet scrubbers (ref. 11).

The collection efficiency of wet collection devices is related to the energy input to the equipment. The high operating cost of high-energy scrubbers can result in total costs as high as high-temperature fabric filters and ESP. The high-energy scrubbers can achieve collection efficiencies from 90 to 99 percent for small particles and may have applicability to recirculation system design. Low-energy scrubbers have much lower collection efficiencies for small particles, from 40 to 80 percent, and would have very limited applicability to recirculation systems.

#### Cost Data

Cost data on ACE can be found in a number of sources. However, data are scarce regarding absorbers and adsorbers, most likely because each installation is assumed to be unique and often proprietary. With regard to particulate collectors two primary sources have been identified (refs. 5, and 16). Cost data, dating from 1969, are summarized in table 3 for three types of particulate collection equipment (ref. 16).

Of note in this summary are the generally higher installation costs of fabric filters over ESP equipment, and the high operating cost of wet collectors. It should also be noted that all of the data are not presented on a comparable basis.

Table 3. Cost data for particulate collection equipment.

Type of collector + gas flow extremes	Installed cost range (\$1,000)	Annualized operating cost range (\$1,000)
Wet collector @ 5,000 acfm	3 - 20	1 - 10
Wet collector @ 350,000 acfm	60 - 400	60 - 400
High voltage ESP @ 20,000 acfm	35 - 100	5 - 15
High voltage ESP @ 1,000,000 acfm	500 - 1,200	90 - 200
Low voltage ESP @ 5,000 acfm	10 - 25	2 - 3
Low voltage ESP @ 100,000 acfm	150 - 350	20 - 50
Fabric filter @ 10,000 acfm	10 - 35	3 - 6
Fabric filter @ 1,000,000 acfm	600 - 1,800	200 - 300

It should be noted that variation in ACE cost, especially on an installed basis, is difficult to estimate, and the use of comparative figures is to be done only with caution. Some factors that are variable and make useful cost data difficult to obtain are price variability with volume capacity, accessories included, installation costs, and special construction.

#### DESIGN APPROACH

The design of air cleaning equipment as components of recirculation systems does not involve a single approach. Many parameters must be identified and interrelationships must be understood as the first step of the design process. There are six general areas that must be evaluated in order to proceed with design:

1. Characterization and variability of airstream and contaminants to be recirculated:
  - a. gas properties,
  - b. contaminant properties,
  - c. mass flow rate, and
  - d. buildup of contaminants;
2. Collection required:
  - a. gas removal,
  - b. particulate removal, and
  - c. allowable exhaust and work area concentrations;
3. Equipment capability, limitations, and reliability:
  - a. wet or dry system, and
  - b. efficiency;

4. Residue disposal:
  - a. liquid waste, and
  - b. solid waste;
5. Costs:
  - a. purchase,
  - b. installation, and
  - c. operating; and
6. Operation and maintenance requirements.

Characterization is a very important consideration and should include determination of gas volume, temperature, and moisture content; particle size distribution, density, explosiveness, and concentration; and gas and vapor concentrations.

The selection of a particular piece of air cleaning equipment is based on the degree of contaminant removal that is required. In recirculation systems it must be recognized that monitoring equipment must also be built into the system to help insure proper performance. The general capability and limitations of existing ACE have been previously reviewed in this paper. However, each design must be approached with the objective of acquiring current equipment performance data in order to make the best selection possible.

The disposal of ACE residue is a very important consideration, whether the residue is in the liquid or solid state. This operation must be recognized as an integral component of the cleaning process requiring design attention and cost.

Meaningful cost data are very hard to obtain and use with confidence. Again, each design must include a specific effort to obtain the best available cost figures to form a basis for achieving the best performance for the least cost.

Poor maintenance and improper operation of ACE must be prevented since such practices could result in the return of highly contaminated air to the breathing zone of workers. The proper time to initially address operation and maintenance (O & M) requirements is during the design phase. A specific O & M plan should be developed as a major element of each design.

The design process is not complete without the analysis, in some depth, of alternative solutions to the problem. The viable options should be identified early in the design process and examined in terms of design configuration, performance, and cost.

Initial efforts have been performed to develop design criteria for recirculation systems including analytical models to predict system performance (ref. 8). Contractual studies sponsored by the National Institute for Occupational Safety and Health are underway to further develop design criteria, and conduct criteria validation studies, including pilot studies of air cleaning/monitoring equipment installations. It is expected that the results of these studies will aid in the establishment of a firm basis for the design of ACE in recirculation systems in the future.

## RESEARCH AND DEVELOPMENT NEEDS

The identification of research and development (R & D) needs is not an easy task, regardless of the technical subject of concern. This is true with regard to the cleaning of exhaust air for industrial recirculation systems. The following discussion will be focused on such needs based on this paper and literature sources. Although there are apparent research needs associated with gas and vapor absorption and adsorption cleaning equipment, literature sources do not generally address such research needs. Therefore, those needs will not be discussed in this paper. The general areas to be discussed include:

1. performance of cleaning equipment in air recirculation systems,
2. electrostatic precipitation,
3. fabric filtration, and
4. wet scrubbing.

In general, there is a clear need for the development of valid design criteria and the generation of performance data related to the design and operation of air cleaning equipment, both primary and secondary, as components of industrial exhaust air recirculation systems. Engineering laboratory and field research is needed to verify both the design criteria and performance data for common industrial operations where energy conservation needs are likely to result in firm incentives to recirculate. Data are lacking at the present time to determine exactly how ACE will perform in the context of air recirculation systems. For particulate collection the data must be obtained on the basis of establishing in-duct particle size distribution and determining the fractional efficiency of collection equipment utilized.

It should be noted that existing test methods and performance data have been established in the context of domestic and commercial air filtration applications. Testing methods and performance data for industrial applications must be developed and published in order to advance the state-of-the-art and the use of ACE with confidence in recirculation systems.

ESP research needs have been comprehensively addressed in a report completed in 1970 (ref. 13). Although nearly 7 years have passed, the needs generally remain valid and the relevant needs are specified below:

1. Refine the system model developed in the report.
2. Determine the role of turbulence and electric wind on precipitator performance.
3. Conduct fundamental studies of spark propagation to define voltage and current relationships.
4. Develop quantitative data to relate reentrainment to dust resistivity.
5. Determine the effect of dust layers on corona generation.
6. Develop improved techniques for collection of small particles.
7. Develop techniques for the collection of high resistivity dust.
8. Conduct research on the application of ESP to the following industries:
  - a. pulp and paper,

- b. metallurgy, and
  - c. cement.
9. Develop improved methods for specifying equipment and contracting to provide adequate assurance of proper performance.

An additional area of ESP research is to develop techniques to prevent the generation of gaseous contaminants from the corona discharge (refs. 18 and 19).

Fabric filter research needs were also developed in a report issued in 1970 (ref. 5). The basic needs that are relevant to this paper and remain valid are as follows:

1. Develop basic data relating particle properties to operating performance and cost.
2. Develop basic data on performance and cost of available fabric media and their surfaces.
3. Determine how improved fibers can be developed for use in filtration systems.
4. Develop improved techniques for system design.
5. Identify and evaluate new fabric filter applications.

Wet scrubbing research needs were documented in a report issued in 1972 (ref. 14). The basic needs identified are as follows:

1. Investigate the basic concepts of collection to improve the basis for design.
2. Develop basic data to better define physiochemical parameters.
3. Develop improved equipment incorporating the results of items 1 and 2.
4. Develop improved methods of engineering design and optimization of systems.
5. Develop improved monitoring instruments and evaluate the dynamic response to upsets.

A number of the needs identified above are not unique to a particular type of air cleaner. Specifically, item 9 under the ESP needs, items 1 and 4 under the fabric filter needs, and each of the items under the wet scrubber needs have general application to ACE.

The control equipment industry is a key factor in attempts to fill the above research gaps. In particular, the industry needs to address the need for ACE designed for use in industrial air recirculation systems. This is not to say that existing equipment is not adaptable; however, both airflows and contaminant concentrations in exhaust air systems can differ considerably from those encountered in process effluent airstreams. A recent technical journal article implies that the long-term outlook for control equipment is totally directed to developing equipment to meet air pollution control requirements (ref. 20). Such trends are encouraging, but other applications must not be overlooked, such as recirculation systems.

## SUMMARY AND CONCLUSIONS

The energy crisis is providing an incentive for industry in the United States to conserve fuel. A major consideration is the recirculation of exhaust air to reduce energy consumption in heating or cooling workplace air. Air cleaning equipment is an essential component of recirculation systems that must be designed to prevent occupational health problems.

Although there is a history of literature on the subject, meaningful design criteria for recirculation systems are very limited. Primary system components are air cleaning equipment and monitoring/alarm equipment. Monitoring equipment requires significant development work in order to assist in safeguarding recirculation systems.

It is very important to evaluate each case on its merits to determine the feasibility of recirculation. If feasibility is established, air cleaning equipment must then be selected to properly remove specific contaminants. ACE is normally designed for the removal of particulates or gases and vapors. Subject to the limitations previously discussed, absorbers, adsorbers, electrostatic precipitators, fabric filters, and wet collectors are considered to be applicable to recirculation system design.

Each of these types of equipment has been reviewed from the standpoint of collection mechanism, equipment configuration, performance capability, and applicability to recirculation. Cost data from 1969 for particulate collectors have been summarized.

A general approach to design of ACE is presented with the following major factors requiring in-depth study as part of the design process:

1. characterization of airstream and contaminants,
2. collection required,
3. equipment capability,
4. residue disposal,
5. costs, and
6. operation and maintenance.

Options must be evaluated to arrive at a specific design approach. Current studies to improve design criteria for recirculation systems are discussed.

Research needs are discussed relating to ACE performance in recirculation systems, ESP, fabric filtration, and wet scrubbing.

The following are the major conclusions that have been reached in this paper.

1. There is a growing interest in the recirculation of industrial exhaust air.
2. Valid design criteria and performance data are badly needed to provide a sound basis for design of recirculation systems.
3. Reliable monitoring/alarm equipment needs to be developed to function in conjunction with air cleaning equipment and aid in safeguarding recirculation systems.

4. There is a wide variety of air cleaning equipment commercially available that has potential application in recirculation systems, including absorbers, adsorbers, electrostatic precipitators, fabric filters, and wet collectors.
5. A comprehensive engineering design approach must be rigorously applied to air cleaning equipment in recirculation systems to insure optimum performance and worker protection.
6. Major R & D for air cleaning equipment is needed to improve the overall capability of the equipment. Laboratory and particularly field investigations are needed to evaluate the performance of such equipment in the context of recirculation systems. The control equipment industry is a key factor in attempts to fill research gaps. Both test procedures and performance data need to be established to define the capability of ACE in industrial applications.

#### REFERENCES

1. J. M. Kane, "Operation, Application and Effectiveness of Dust Collection Equipment," Heating and Ventilating, Vol. 49, August 1952, pp. 87-98.
2. J. C. Barrett, "Design Properly for Ventilation Economy," Archives of Environmental Health, Vol. 6, March 1963, pp. 107-113.
3. W. G. Hazard, "Industrial Ventilation," National Safety News, August 1967, pp. 45-51.
4. P. J. Thompson, "In-Plant Air Cleaning," Pollution Engineering, Vol. 5, No. 12, December 1973, pp. 27-29.
5. American Conference of Governmental Industrial Hygienists, Industrial Ventilation: A Manual of Recommended Practice, Committee on Industrial Ventilation, Lansing, Michigan, 1976.
6. Occupational Safety and Health Administration, OSHA Safety and Health Standards (29 CFR 1910), Subpart Z-Toxic and Hazardous Substances, OSHA 2206, January 1976.
7. C. E. Decker, and C. D. Parker, "Contaminant Monitoring Systems," Recirculation of Exhaust Air - Proceedings of Seminar Held October 23-34, 1975, NIOSH Publication No. 76-186, February 1976, pp. 87-96.
8. W. J. Astleford, "Development of Criteria for the Recirculation of Exhaust Air," NIOSH Publication No. 76-186, February 1976.
9. J. M. Kane, "Air Cleaning Devices for Recirculation of Exhaust Air," Recirculation of Exhaust Air - Proceedings of Seminar Held October 23-24, 1975, NIOSH Publication No. 76-186, February 1976, pp. 77-83.
10. Air Pollution Engineering Manual, J. A. Danielson, ed., EPA Publication No. AP-40, May 1973.

11. Gas Cleaning for Air Quality Control: Industrial and Environmental Health and Safety Requirements, J. M. Marchello and J. J. Kelly, ed., Marcel Dekker, Inc., New York, 1975.
12. J. M. Marcello, Control of Air Pollution Sources, Marcel Dekker, Inc., New York, 1976.
13. S. Oglesdy and G. B. Nichols, An Electrostatic Precipitator Systems Study, NTIS PB: 196 380, 196 381, August 1970 and PB: 198 150, October 1970.
14. S. Calvert et al., Wet Scrubber System Study, NTIS: PB 213 016, 213 017, July 1972.
15. C. E. Billings and J. Wilder, Fabric Filter Systems Study, NTIS: PB 200 648, 200 649, 200 650, 200 651, December 1970.
16. Control Techniques for Particulate Air Pollutants, EPA Publication No. AP-51, January 1969.
17. "Product Guide/1977," Journal of the Air Pollution Control Association, Vol. 27, March 1977, pp. 267-271.
18. M. B. Awad and G. S. P. Castle, "Ozone Generation in an Electrostatic Precipitator with a Heated Corona Wire," Journal of the Air Pollution Control Association, Vol. 25, April 1975, pp. 369-374.
19. D. L. Flamm and U. Tangirala, "The Production and Treatment of Gaseous Pollutants in an Electrostatic Precipitator," AIChE Symposium Series, Vol. 73, 1977, pp. 142-145.
20. S. R. Orem, "Control Equipment Industry," Journal of the Air Pollution Control Association, Vol. 27, September 1977, p. 840.

#### DISCUSSION

MR. JOHN ASHE (American Air Filter Co., Louisville, Kentucky): The ESP does exhibit a very low operating resistance or pressure drop. I believe that is why the chart showed the low voltage ESP as a low operating cost device. As a point of clarification, there are two types of electrostatic precipitators, low and high voltage. Very definitely, speaking for the industry, the high voltage type ESP is not recommended for recirculation systems while the low voltage type is.

Ozone emission from the high voltage ESP could be a problem. The low voltage type, however, was specifically designed to minimize ozone emission and has been used for commercial heating, ventilating, and air conditioning systems since the mid 1930's. Gaseous particulate emission, especially ozone, has been a subject of concern to the industry for years. ESP's have been traditionally used for commercial ACT systems, and through modification of design and applicability internal R & D learned where it was generated, and it has been a subject of general control. In fact, in some of our field tests we've found that the out-

side level has exceeded that given off by ESP. In certain laboratory applications where absolute control is desired, a two-stage approach is used where ESP is followed by an absorber, specifically activated carbon, and solved it. However, the normal emission level is significantly low with respect to TLV, according to our tests.

MR. TALTY: I don't think I disagree with anything you said. I think I was pointing out the fact that such contaminants can be generated.

MR. WILLIAM CHENEY (United Air Specialists, Cincinnati, Ohio): The problem is that for years this has been mentioned and never been put to rest. I'm not acquainted with the test that he referred to. I'm acquainted with some of our own, and the ozone production is well below TLV. Honeywell had a test run on their residential air cleaner, and again the internal air going through the ESP was much below the ozone level present outside, and I would like to see if anyone has evidence that the ozone produced by ESP exceeds that TLV for factory air. The State of Pennsylvania for years had a ruling that ESPs could not be used for recirculation of air because of the deadly ozone condition.

MR. TALTY: I think there are data available as to what the generation rate is. You're saying that the gas is generated at a concentration less than the TLV for ozone?

MR. CHENEY: I'm saying factory air in any normal ESP application is well below it.

MR. TALTY: I don't have data at hand that would contradict or support that, and it would be good to cite the data if you can make it available.

MR. CHENEY: I would be glad to give it to you. The question comes up so often I would like to have it clear at some authoritative level. I think it is erroneous.

## MONITORING OF PARTICULATES IN RECIRCULATED AIR

Steven H. Chansky\*

### Abstract

*The various categories of particulate monitoring instruments are identified along with criteria for successfully monitoring particulates in recirculated exhaust air. Each category of instruments is evaluated against these criteria as part of a selection process for identifying the optimum instrumentation. The selected categories are then further examined in terms of their advantages and limitations. Some general comments are also made with regard to the selection of instruments to monitor gaseous pollutants in recirculated exhaust air.*

### INTRODUCTION

While listening to several of the previous papers presented at this symposium and the discussions which ensued, there seemed to be some question as to the definition of monitoring in the context of recirculated air. Therefore, I would like to begin this presentation with my understanding of the definition of monitoring:

The direct readout of the concentration of a subject contaminant on a real-time or continual basis. This is differentiated from the term sampling, which involves manual analytical/weighing procedures.

Please note that this definition does not specify the point of measurement. This provides the latitude of considering either in-duct monitoring at a point or points prior to the release of recirculated air into the work environment, or area or personal monitoring directly in the work environment.

Although the primary emphasis of this paper is to be particulate monitoring, gaseous monitoring is also discussed. Since this latter topic includes over 350 compounds listed in the Federal Register, only a brief presentation about monitoring gaseous substances, which is applicable "across the board" yet not so general as to become trite, will be included. The focus of the presentation will be discussion of the varying monitoring applications for which commercial instruments currently exist, those parameters to be considered in evaluating and selecting instruments for monitoring recirculated air, and some selection hints.

---

\*Manager, Instrumentation Marketing, GCA Corporation, Bedford, Massachusetts.

## GENERAL DISCUSSION OF GASEOUS AND PARTICULATE MONITORING

Table 1 lists the five primary measurement domains in which monitoring instruments are currently utilized. These instruments are typically designed for use in a specific domain and should not be casually utilized in alternative environments. The selection of a commercial instrument for monitoring one or more substances in air should be based on a careful evaluation of the relevant measurement parameters. These parameters are listed in table 2 and include both independent and dependent parameters. The independent parameters relate to the monitoring environment, whereas the dependent variables are related to the monitoring instrument itself.

It should also be noted that some of these parameters impact more on specific airborne contaminants than others. For example, the nature and degree of air movement and particle size distribution are of more concern when monitoring particulates than with gaseous substances. The overall message, therefore, is to be careful in selecting instrumentation. Make sure that the instrument design and sensing principle you are considering is compatible with your mon-

Table 1. Five primary measurement domains.

---

---

1. Outside (ambient) air
2. In-plant air
3. Stack (stationary source) emissions
4. Automotive exhaust (mobile source) emissions
5. Ventilation ducts

---

Table 2. Measurement parameters.

---

---

Independent
• Concentration range of pollutant
• Condition of effluent (temperature, humidity, pressure, interference agents, etc.)
• Movement (velocity, turbulence) of air being monitored
• Particle size distribution
• Chemical composition
Dependent
• Instrument sensing method
• Instrument design

---

itoring requirements. There are many qualified consulting organizations available to assist in the selection process and I encourage you to use them to augment your in-house capabilities when necessary.

#### CATEGORIES OF PARTICULATE MONITORING INSTRUMENTS

In order to assess the suitability of utilizing commercially available instruments to monitor particulate contaminants in recirculated exhaust air, a listing of candidate instrumentation was prepared. Table 3 presents these general categories of particulate monitoring instruments along with some of their respective manufacturers. This listing of manufacturers is not meant to be all inclusive nor should it be considered an endorsement of their products. An attempt is made, however, to identify the major suppliers of each instrument category to provide the reader with a starting point in the event that more specific information is desired.

As table 3 illustrates, there are seven general categories of particulate monitoring instruments available. Light scattering instruments are subdivided into particle counters, which count the number of individual airborne particles in a measured air sample by size range, and nephelometers or photometers, which measure the general scattering of light by particles in a volume of air. In the latter case, the resulting signal can be related to the mass concentration of the particles over a discrete particle size range, knowing the density of the particles.

The second category is opacity monitors, which measure the degree of opacity of particulates in a gas stream. An optical receiver measures the amount of light that is transmitted through the airborne particulates from a light source. The degree of opacity is dependent upon the size distribution and optical properties of the particulates being monitored.

Optical tape samplers, the third category, is similar in principle to opacity monitors except that the particles are collected on a filter tape prior to the measurement of light transmission. The resulting Coefficient of Haze (COH) signal is also dependent on the physical and optical properties of the collected particulates.

The fourth category, called electrical methods, is comprised of three subcategories. The first, electric charge transfer, involves the impaction of a particulate against an electrically conductive sensing element resulting in a small current. The current is then amplified and converted into a voltage readout. The mobility analyzer, the second subcategory, utilizes electrostatic techniques for particle detection. The entering aerosol is electrostatically charged with a number of ions proportional to its size. The charged particles are caused to flow to a current sensor that measures the total collected charge and displays the results in digital or analog format. The third subcategory, ionization gauges, more commonly known as smoke detectors, draws an aerosol into a chamber, resulting in a reduction in the detected ionization current within the chamber.

Condensation nuclei counters comprise the fifth category of particulate measurement instruments listed in table 3. This instrumentation is designed to detect and measure submicron airborne particles. The air being sampled is

Table 3. General categories of particulate monitoring instruments.

- 
- A. Light scattering instruments
    - 1. Particle counters--count individual particles by size  
Bausch & Lomb, Climate, Royco, Particle Measuring Systems
    - 2. Nephelometer or photometer--general scattering of a volume of air  
Leitz Tyndallometer, MRI, Weathermeasurer
  - B. Opacity monitors  
Lear Siegler, RAC, Dynatron
  - C. Optical tape samplers  
RAC, Bendix, GCA
  - D. Electrical methods
    - 1. Electric charge transfer  
Ikor
    - 2. Mobility analyzer  
TSI
    - 3. Ionization gauge  
(only smoke detection and alarm instruments commercially available)
  - E. Condensation nuclei counters  
Environment One Corporation
  - F. Piezoelectric mass monitors
    - 1. Collection by electrostatic precipitation  
TSI
    - 2. Collection by impaction  
Celesco
  - G. Beta attenuation mass monitors
    - 1. Collection by impaction  
GCA
    - 2. Collection by filtration  
GCA, Philips, Frieseke Hoepfner
- 

drawn through a humidifier and then into a cloud chamber in which water is condensed upon the submicroscopic particulates to produce a cloud of micron-sized droplets. The degree of attenuation of a light beam by this cloud is then sensed and recorded.

The sixth category of instruments utilizes piezoelectric techniques to detect and monitor particulate mass concentration. Particles are collected either by electrostatic precipitation or impaction on a vibrating quartz crystal and the change in resonant frequency is measured as the particles are collected. The results can be displayed as an analog output or in digital format.

The last category, beta attenuation instruments, collects the sample on a substrate either by filtration or impaction. The mass is then determined by

the degree of attenuation or absorption of beta radiation passing through the sample from a radioactive source (located above or below the collected sample) as measured by a sensor such as a geiger detector located at the opposite side of the substrate.

#### CRITERIA FOR INSTRUMENT SELECTION

The several categories of particulate monitoring instruments discussed above have each been developed for use in a specific domain and for measuring specific parameters that include: concentration by number of particles; concentration by mass; submicron particle measurement; respirable particle measurement; the measurement of large particles only; etc. The application under discussion, however, has its own set of unique requirements and the objective is to best match the performance specifications of these instruments with such requirements.

In order, then, to meet this objective, a set of six selection criteria was developed and is presented as part of table 4. The first criterion is that the mode of operation be real-time or continual. The reasoning is that the selected monitor must have a fast response time to changes in contaminant levels so that corrective action can be initiated and completed before unacceptable workplace concentrations are reached.

The second criterion is that the instrumentation must perform accurately within a concentration range which brackets the TLVs for the particulate contaminants being monitored. Focusing in on the TLVs for silica-containing, nuisance, and other common particulate contaminants, these ranges are:

0.1 - 15 mg/m<sup>3</sup> or 2 - 5 mppcf.

Please note that although there are parallel mass concentration and particle count standards in the Occupational Safety and Health Administration (OSHA) regulations, these are not interchangeable. In fact, it is very likely that you may be meeting one standard, but be out of compliance with another.

Because of the above dichotomy, a third criterion specifies that the mass concentration standard be the one recognized, and therefore requires that the output from the selected instrumentation be directly related to mass concentration. The rationale here is that OSHA and Mining Enforcement and Safety Administration (MESA) have widely adopted gravimetric (mass concentration) techniques as their methods of compliance and that the results from any instrument selected for this application should be directly compatible with these compliance methods.

The next two criteria relate to the aerodynamic particle size ranges for respirable and total dust. If only respirable dust is being measured, the selected instrument should be capable of collecting and monitoring the particle size range which penetrates a respirable cyclone precollector. The upper particle size associated with this range is 10  $\mu$ m. If total dust is to be measured, however, the monitoring device should be capable of measuring the same particle size range as the total dust compliance or reference method. This method, as specified by OSHA, involves the use of an inverted closed-faced 37-mm filter at a flow rate of 2 l/min. This author was, however, unable to

Table 4. Categories of particulate monitoring instruments  
vs.  
selection criteria.

Criteria	Categories of particulate monitoring instruments				
	Light scattering particle counter	Nephelometer	Opacity monitors	Optical tape samplers	Electric charge transfer
Mode of operation (real time or continual)	Real time or continual	Real time	Real time	Continual	Real time
Concentration range (0.1-15 mg/m <sup>3</sup> [2-50 mppcf])	Up to 100 mppcf	0.01-100 mg/m <sup>3</sup>	Above 10 mg/m <sup>3</sup>	Less than 50 mg/m <sup>3</sup>	0.02-2 x 10 <sup>5</sup> mg/m <sup>3</sup>
Particle size range--respirable (up to 10 micrometers)	0.3-10 micrometers using cyclone	Up to 5 micrometers	Respirable range cannot easily be segregated	Down to 0.3 micrometers	Respirable range cannot easily be segregated
94 Particle size range--total (up to 20 micrometers[?])	0.3 ->10 micrometers	Insensitive to large particles in presence of small particles	Insensitive to large particles in presence of small particles	Down to 0.3 micrometers	Down to approximately 1.0 micrometer
Units of readout (mass concentration)	Particles/ft <sup>3</sup>	mg/m <sup>3</sup>	Percent opacity	Coefficient of Haze (COH)	Proportional to gr/scf for constant density, particle size distribution
Attention and maintenance level (minimal)	Low	Low	Low	Low	Low
Alarm signaling capability (yes)	Yes	Yes	Yes	Yes	Yes

(continued)

Table 4 (con.)

## Categories of particulate monitoring instruments

Criteria	Mobility analyzer	Condensation nuclei counter	Piezoelectric and electr. precip.	Piezoelectric and impaction	Beta attenuation and impaction	Beta attenuation and filtration
Mode of operation (real time or continual)	Real time	Real time	Continual	Real time or continual	Continual	Continual
Concentration range (0.1-15 mg/m <sup>3</sup> [2-50 mppcf])	>2,000 mppcf	Up to 1,000 mppcf	0.1-10 mg/m <sup>3</sup>	0.001-2.0 mg/m <sup>3</sup>	0.02-150 mg/m <sup>3</sup>	0.005-300 mg/m <sup>3</sup>
95 Particle size range--respirable (up to 10 micrometers)	0.005-5 micrometers	Below 0.3 micrometers	Up to 8 micrometers	0.1-10 micrometers with cyclone	0.4-10 micrometers using cyclone	<0.1-10 micrometers using cyclone
Particle size range--total (up to 20 micrometers[?])	0.005-5 micrometers	Below 0.3 micrometers	Up to 8 micrometers	0.1-100 micrometers	0.4-20 micrometers	<0.1-100 micrometers
Units of readout (mass concentration)	Particles per cm <sup>3</sup>	Nuclei/cm <sup>3</sup>	mg/m <sup>3</sup>	mg/m <sup>3</sup>	mg/m <sup>3</sup>	mg/m <sup>3</sup>
Attention and maintenance level (minimal)	Low	Low	High-frequent cleaning of crystal required	High-frequent cleaning of crystal required	Low	Low
Alarm signaling capability (yes)	Yes	Yes	Yes	Yes	Yes	Yes

determine from discussions with NIOSH personnel and other experts in aerosol measurement the upper end of the aerodynamic particle size range sampled via this method. Best estimates seem to suggest that this level would be under 20  $\mu\text{m}$ . Consequently, up to a 20- $\mu\text{m}$  detection capability is specified as the criterion for total dust monitoring, pending additional information.

The last two criteria require that the attention and maintenance level of the instruments be minimal and that the instrumentation offer alarm signaling capability. These are essential requirements to insure reliable long-term operation in industrial environments, as well as the ability to quickly respond in the event that excessive concentrations occur.

#### COMPARISON OF INSTRUMENT CATEGORIES AGAINST SELECTION CRITERIA

Table 4 compares the various categories of particulate monitoring instruments against the seven selection criteria discussed above. The information in this table was compiled from data sheets and brochures of instrument manufacturers, as well as from published information and discussions with scientists and engineers familiar with the design and application of these instruments.

For each category of instruments, the performance specifications pertaining most to the selection criteria are listed. In those cases where there is a definite mismatch between the criteria and performance specifications, a "box" is drawn in to signify this mismatch. The instrument categories best suited to monitoring particulates in recirculated air are those where the performance specifications are most compatible with the selection criteria and where no significant mismatches exist.

This evaluation indicates that two classifications, the nephelometer and beta attenuation, should be further considered in monitoring recirculated air. Both these instrumentation categories are discussed below.

#### A FURTHER EXAMINATION OF THE NEPHELOMETER

As an example of this category of particulate monitoring instrumentation, a schematic of the Tyndallometer, is shown in figure 1. This instrument, manufactured by Leitz in West Germany, is designed for in situ measurements as the sensing chamber is positioned directly in the dust-laden air to be sampled. A luminescence diode (wavelength 0.94  $\mu\text{m}$ ) serves as the light source, and a silicon diode receives the light scattered in an angle of 70°. A direct digital display or analog output is available. As outlined in table 5, an advantage of this unit is that it does perform in situ measurements, obviating the need for a pump to draw a sample into the unit. Also, low maintenance and a direct digital readout in  $\text{mg}/\text{m}^3$  are other benefits.

Although the Tyndallometer is basically insensitive to variations in particle size within the range of about 0.4 to 5  $\mu\text{m}$ , the presence of submicron particles will tend to overwhelm the instrument, resulting in excessively high results. Conversely, the Tyndallometer is relatively insensitive to the presence of larger particles (above 5  $\mu\text{m}$ ), resulting in readings biased on the low side. Also, the unit is calibrated for a specific mass density and care should be taken in applications where variations in density can occur.

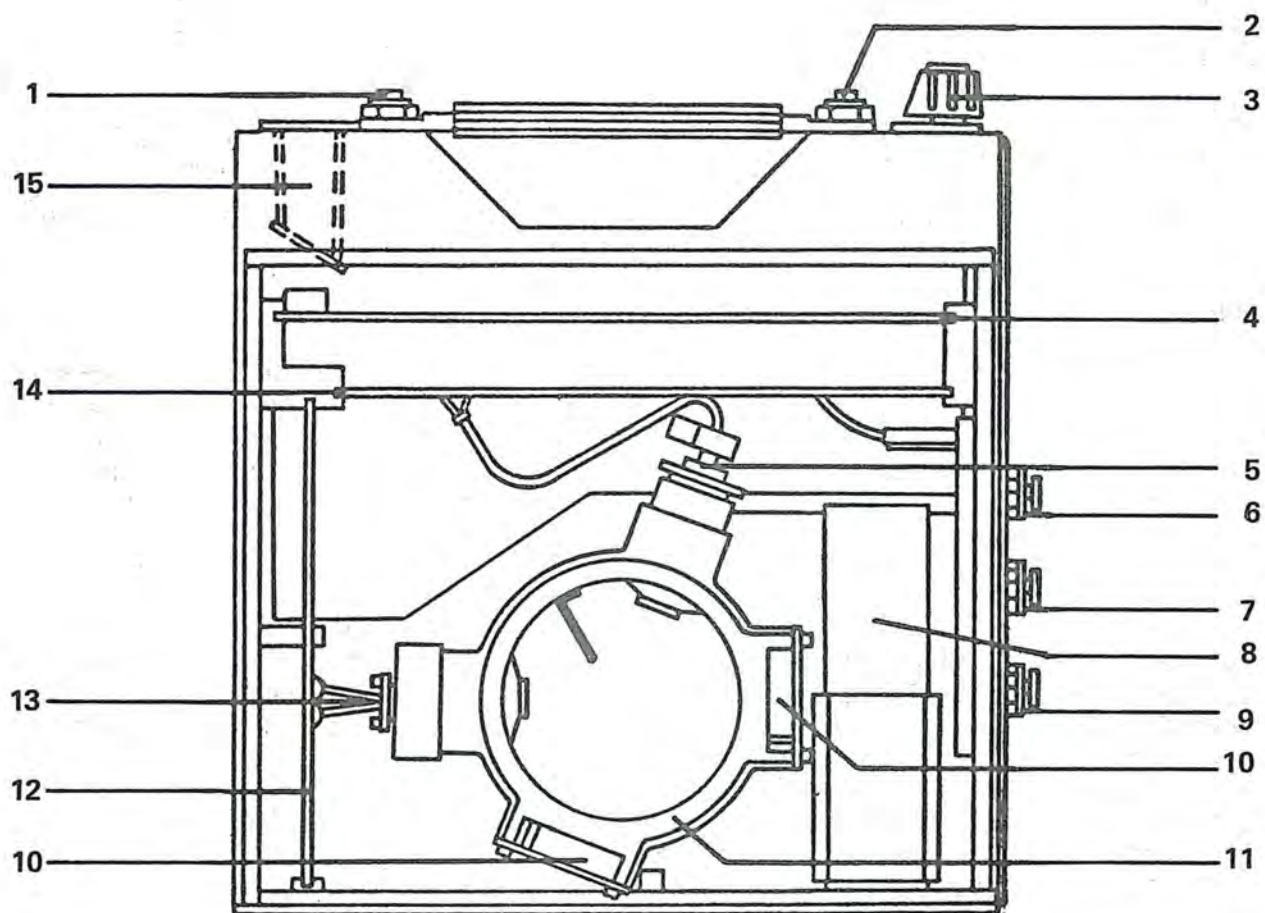

- |   |                                      |   |                                       |    |                                |
|---|--------------------------------------|---|---------------------------------------|----|--------------------------------|
| 1 | Key                                  | 5 | Photo diode                           | 10 | Light trap                     |
| 2 | Balancing key for zeroing            | 6 | Data output                           | 11 | Measuring chamber              |
| 3 | Range switch (measuring mode switch) | 7 | Analogue output                       | 12 | Operating control              |
| 4 | a.c. converter                       | 8 | d.c. converter                        | 13 | Glow diode                     |
|   |                                      | 9 | For mains units or battery connection | 14 | Amplifier                      |
|   |                                      |   |                                       | 15 | Digital measured value display |

Figure 1. Schematic of the Tyndallometer manufactured by Leitz.

Table 5. Further examination of the nephelometer.

---

Advantages

- In situ measurement
- No moving parts--low maintenance
- Direct digital display in  $\text{mg}/\text{m}^3$

Limitations

- Insensitive to particles much above 5 micrometers
  - Presence of ultra fine particles can bias results upward
  - Assumes a specific particle mass density
- 

#### A FURTHER EXAMINATION OF BETA ATTENUATION PLUS IMPACTION

The Model RDM-301 Recording Dust Monitor manufactured by GCA Corporation is an example of this category of particulate monitoring instrumentation. A photo of the unit is shown in figure 2. Dust is collected by impaction as a "spot" on a coated Mylar disc capable of advancing automatically after each cycle with a capacity of 450 samples per disc. A carbon 14 source is utilized as the beta-emitting isotope and the sensor is a Geiger Mueller Detector. The cycle time is programmable from 1 to 99 minutes.

As shown in table 6, the basic advantage of the RDM-301 is that the measurement principle is directly proportional to mass and a digital tape printout directly in  $\text{mg}/\text{m}^3$  is provided. Also the unit can be operated for several shifts without attention. The two primary limitations of the unit for this application are that particles below  $0.4 \mu\text{m}$  in aerodynamic diameter are not collected and therefore not measured; secondly, if in-duct monitoring is required, the sample has to be extracted via a probe with the concomitant possibility of some particle losses within the probe.

#### FURTHER EXAMINATION OF BETA ATTENUATION PLUS FILTRATION

To illustrate this category, a photograph of the Model APM, Aerosol Mass Monitor, is presented in figure 3. This instrument, manufactured by GCA Corporation, collects the dust sample on a high-efficiency filter and measures the mass by beta radiation attenuation. As listed in table 7, the incremental advantage of this approach vs. collection by impaction is that the filter collects particles across the entire particle size spectrum for measurement. Also, a novel flow control system maintains a constant flow. This specific instrument also has been successfully field tested for monitoring particulates in recirculated air from baghouses by the major asbestos producers in Quebec. The primary limitation of this unit is the need to extract the air sample via a probe if in-duct monitoring is required.

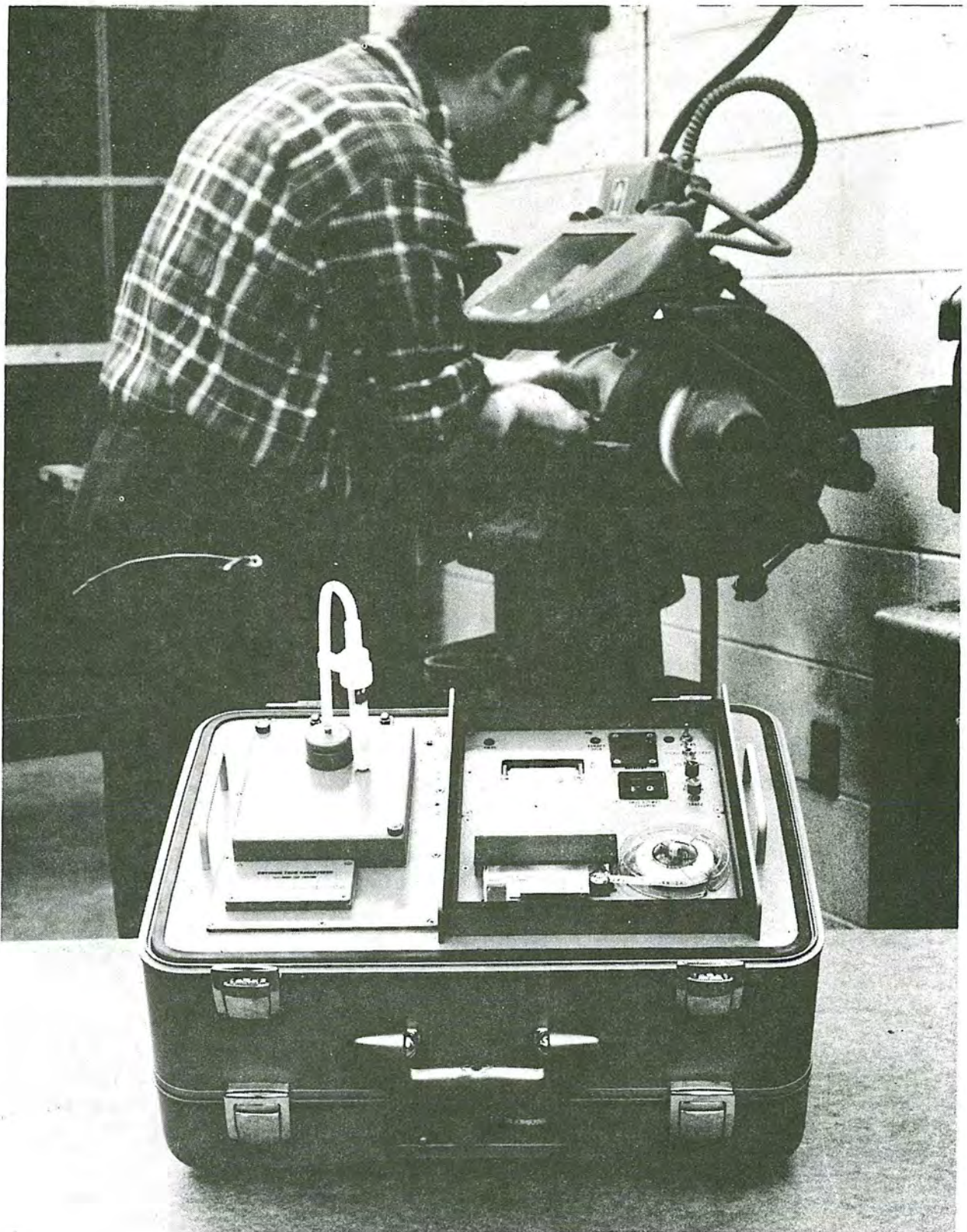

Figure 2. Photo of model RDM-301, recording dust monitor manufactured by GCA Corporation.

Table 6. Further examination of beta attenuation plus impaction.

---

---

Advantages

- Direct readout in  $\text{mg}/\text{m}^3$
- Attenuation of beta radiation directly proportional to mass
- Can be operated for several shifts without attention

Limitations

- Mass contribution of particles below 0.4 microns (aerodynamic diameter) not measured
  - Sample extracted from duct via probe
- 

Table 7. Further examination of beta attenuation plus filtration.

---

---

Advantages

- Direct readout in  $\text{mg}/\text{m}^3$
- Attenuation of beta radiation directly proportional to mass
- High-efficiency filter collects particles across entire particle size spectrum (<0.1-100 micrometers) for measurement
- Constant flow control
- Field tested downstream of baghouses by major asbestos producers in Quebec

Limitations

- Sample extracted from duct via probe
-

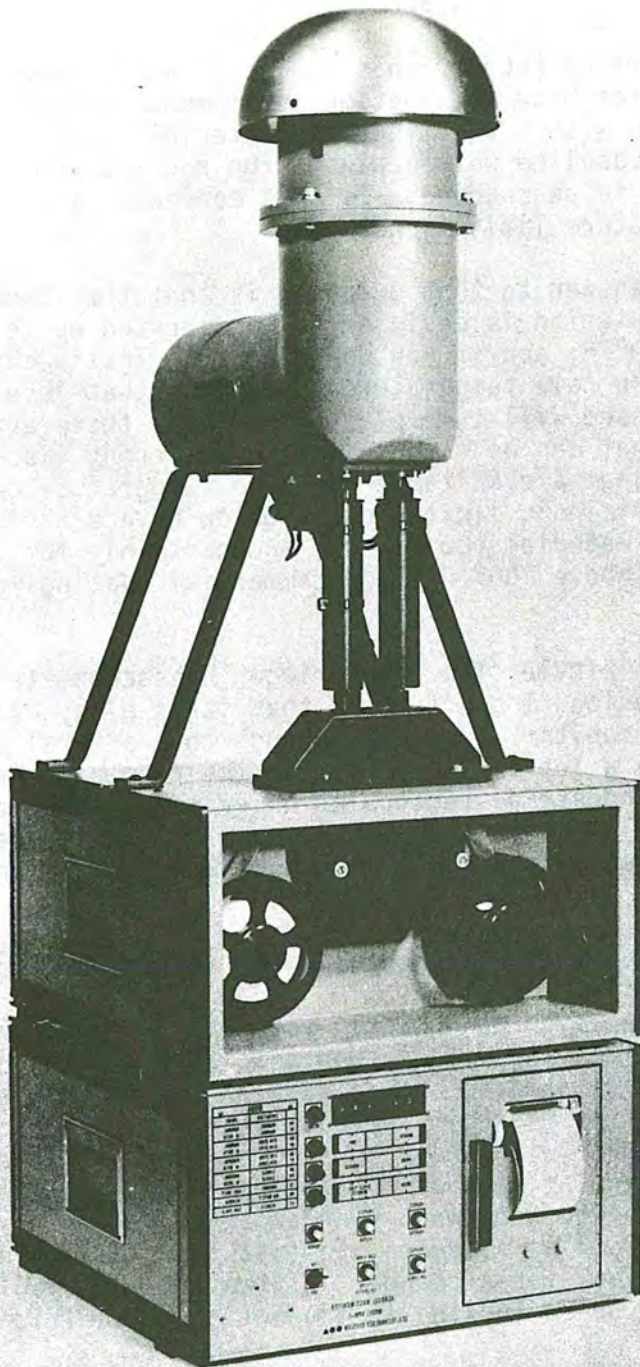

Figure 3. Model APM, aerosol mass monitor (pump module not shown) manufactured by GCA Corporation.

## DISCUSSION

MR. WILLIAM HUELSEN (American Foundrymen's Society, Des Plaines, Illinois): I've heard that on the beta attenuation instruments where you use the disc which is coated with a vaseline-like material, that for warm or hot gas conditions the vaseline will begin to run and the sample will disperse and will give you a false reading. Is this correct? If it is correct, what are the temperature limitations?

MR. CHANSKY: Bill, the answer to that question is that the standard type of commercial instrumentation is designed to be operated up to temperatures of approximately 100° F, and if you do bring such instrumentation into an environment where you have temperatures exceeding that level, the phenomenon that you discussed will take place. However, there are several coating materials that can be used that have different viscosities, and we know of several that are suitable for high temperature applications, so this is not an intrinsic limitation. You do have a choice in terms of the type of coating material you select, and certainly for high temperature applications (above 100° F), the commercial coating would not be recommended.

MR. SCOTT STRICOFF (A. D. Little, Inc., Cambridge, Massachusetts): In the context of recirculation, I don't think that it is always true that you require a real-time monitor. We went through that several times this morning, and I think a lot of the people in the room also believe that in some, if not many, industrial recirculation systems, there are potential situations where real time isn't a requirement. It all depends on the specifics of the location and contaminants, the airflows, and a lot of other things.

MR. CHANSKY: What is required? What would be the replacement for real time?

MR. STRICOFF: It all depends on how quickly you get into a dangerous situation. If all you're dealing with is nontoxic dust, it may be perfectly adequate if the area is sampled once a day. It depends on the situation. The second point is regarding output, and the virtues of mass versus count. I don't disagree with what you said in general terms, although, again, for this particular kind of an application it may be sufficient in some situations where you know what your expected values are, particularly where you're looking at ducts, to just look for an "off-spec" kind of a situation, and look for a change. If that is what you're looking for, then the units you're looking at are not that significant.

MR. CHANSKY: I would say that if you're looking simply for a type of instrument for your application, you're absolutely correct. In terms of something which monitors on a continual, not continuous but continual basis, where you're acquiring data not only on whether you're exceeding the levels or not, but also on what the levels are, for recordkeeping purposes and whatever else that might be required, then mass concentration may be more desirable. Again, to use the terminology you used, I would like to think of these more as guidelines, and I'm sure there are many exceptions that can be mentioned.

MR. LARRY BULLOCK (Envirex, Milwaukee, Wisconsin): I was wondering why you might have excluded devices which are specific for contaminants in your criteria? I think in some applications where exhaust might be, some mechanics are interesting and might be useful.

MR. CHANSKY: Currently, of course, there is no continuous real-time particulate monitor that gives you mass concentrations specific to a given constituent. The way to get around that is by being very conservative, and by knowing what the range of concentration is of a specific constituent existing in your facility. For example, I know Joe Medved up in Saginaw, in central foundry of GM; his people have done a study using personal monitors where they've taken a number of samples periodically and come up with a very good handle on the range of silica levels at various locations in his plant. They can say with confidence that, for example, 95 percent of the time the silica level would not exceed 15 percent in location X. They'll then select a TLV based on this upper silica level. You may be hurting yourself more than is necessary, but the conservative approach in this particular application would probably be recommended, although again, you have to consider each case individually.

MR. BRUCE MENKEL (Bruce Menkel Consulting Engineers, Dayton, Ohio): Question about the application of GCA model APM in Canada, downstream of the bag houses in the asbestos: is that a recirculation operation emission?

MR. CHANSKY: Yes, recirculation emission and ambient air, both. They are recirculating a certain percentage of air back to the workplace. What that percentage is, I'm not sure. I don't know the percentage, but up in Canada, it is mighty cold, and during the wintertime they do recirculate air, returning from the bag house back into the plant.

MR. MENKEL: Use of the APM, are they monitoring just on a concern with bag breakage, or are they also into fiber?

MR. CHANSKY: No, they are using the nephelometer as an indication of bag breakage, but with the APM they are using it as a continual monitor to assure themselves at any time they are not exceeding some preset levels for asbestos. Now again, I don't know how much asbestos is in the mass sample, but they assume 100 percent asbestos, and for those of you interested, please write your comments and I will be able to give you the names of the people most knowledgeable in the Province of Quebec on the program.

MR. DON SCARBROUGH (Nordson Corporation, Amherst, Ohio): Question on your determination of respirable technique: I presume you're using nylon mat cyclone. Can you comment upon the effect of your results of having electrostatic charge borne upon the particulate matter?

MR. CHANSKY: Let me preface any comments I make by saying that this piece of plastic has probably had more money spent on it per pound or per ounce than anything else I can think of in evaluating a specific tool. There have been studies, and I can't specifically name them, on the effect of electrostatic charge on the cyclone. I would be happy to find out for you and get back to you, but GCA has not been involved in any studies of that type.

MR. WILLIAM HEITBRINK: Several years ago, a coworker, Bruce Almich, studied the effect of electrostatic charge upon the nylon cyclone's penetration and found some effects. The cyclone's penetration was affected slightly and the reproducibility of the data was affected. Details of this study can be found in the AIHAJ, vol 35, pp 603-611 (1974). Caplan et al. found that charge had no effect upon cyclone performance. A report of their work can be found in the AIHAJ, vol 38, pp 162-173.

Earlier you mentioned that the capture efficiency of the Millipore 37-mm filter holder has never been fully evaluated. I believe that this is true for all industrial hygiene air sampling devices used to measure total aerosol. The effect of ambient air velocity upon capture efficiency has received very little attention. Some literature which contains relevant experimental data is as follows:

1. Breslin and Stein, 1975, Efficiency of Dust Sampling Inlets in Calm Air, AIHAJ 36: 576-583.
2. Raynor, 1970, Variation in Entrance Efficiency of a Filter Sampler With Air Speed, Flow Rate, Angle, and Particle Size, AIHAJ 31: 294-304.
3. Ogden and Wood, 1975, Effect of Wind on the Dust and Benzene-Soluble Matter Captured by a Small Sampler, Annals of Occupational Hygiene 17: 187-195.

Because these references do not contain specific data on the effect of orientation and wind speeds between 50 and 200 ft/min upon the capture efficiency of the closed-face 37-mm filter holder, NIOSH plans to study these effects contractually.

MR. CHANSKY: For those of you familiar with the Davis criteria for sampling aerosols, estimates of largest particle to be sampled using a personal filter are less than 10 mm. However, there are other criteria that set the upper level much higher than 10 mm. Speaking to some of the NIOSH people directly and asking them the question, they, as you indicated, don't know, and you verified you will be conducting a study this year. Is that correct?

MR. HEITBRINK: Yes.

VALIDATION OF DESIGN CRITERIA  
FOR RECIRCULATION OF INDUSTRIAL EXHAUST AIR SYSTEMS

Lawrence F. Bullock\*

Abstract

*The design guidelines that are recommended in the subject report need to be validated or modified as an added assurance of their usefulness. The best way to check the design criteria is to actually apply them to real-life industrial situations.*

*A status report of efforts to study recirculation in three types of industries is described. Evaluations are ongoing in a foundry, a woodworking facility, and a lead battery manufacturing facility. At the foundry, the potential for recirculation is being evaluated, but results are not available because the study is just underway. Ongoing evaluations at the woodworking and lead battery plants show favorable results, although the investigations are not yet complete.*

Recirculation. Stop and think what it means. I think we have been using that word so often that we sometimes forget exactly what is happening. Imagine deliberately returning partially contaminated air that has a potential for serious consequences upon the health of workers back into a plant area. It must be a serious problem that causes people to do this. It is a serious problem; one on which previous speakers have often dwelled, and whose consequences we feel every day of our lives. I am not here to preach about the energy crisis, but to put recirculation in a light in which we can better see it.

I'm here to discuss the importance of "validation," a word that implies that something is going to be verified or checked, then perhaps disproved, approved, or even modified. However, I do not consider the evaluations that I am about to describe to be a final check, but only a check--a further step beyond the initial approach. All I am saying is that refinements will naturally arise as recirculation technology grows, whether it is due to the advent of a new filter that can be recleaned, or the introduction of some new, sophisticated monitoring device.

The need for a workable set of guidelines is clear, as evidenced by the recent increased interest among energy-conscious plant management. Unfortunately,

---

\*Project Engineer, Envirex, Inc., Milwaukee, Wisconsin.

many plants have responded to the economic pressures of the day or perhaps to the poor advice of an equipment salesman eager to make a fast sale, and have installed systems that sometimes cause more harm than good.

I have seen plenty of attempts to recirculate that have failed. I would like to share a few of them with you today to emphasize the urgent need for proper design criteria. I only present these cases to show that sincere attempts have often been made to recirculate without proper consideration of all the important variables and consequences. I think that the following examples demonstrate this all too clearly.

The first example involves a decision by plant personnel at a certain foundry to pursue the idea of recirculation. Their motivation came after assessing that their energy usage must somehow be cut following a perilous winter filled with threatened gas cutoffs and reduced allocations. As a result, a baghouse exhausting a silica-contaminated exhaust stream was evaluated for its recirculation potential. Consequently, they contracted a sheet metal firm, which designed a system and soon had it installed. After some period of operation, the plant manager asked what would happen if there was some kind of failure in the system. After a quick phone call to the sheet metal firm that installed the system, he learned that a damper would "automatically" bypass the exhaust air in the event of a failure. Not being a person who believed everything he was told, the plant manager inspected the system only to find out that there was indeed a damper in the duct, but that the only method of deployment was manual. Later, an inspection of the exhaust stream revealed a broken bag that had thus far gone undetected. Recirculation was stopped immediately.

In another foundry, a system was designed so that emissions from several different sources were directed to a baghouse and then recirculated. One of the sources happened to be a casting cooling tunnel where hot, decomposing binders were emitting various gaseous products, including carbon monoxide. No attention was directed to the gases in the design, although one plant official remarked that he thought he was going to check for it sometime this winter.

Finally, in another plant, an engineer must have decided that too much heat was escaping from a furnace through an overhead ventilator. He solved the problem by placing an exhaust fan on one of the vertical sides of the hanging overhead canopy that blew the hot air back into the room.

You can see that those two types of engineers would have benefited from a good, workable set of guidelines. The first type realizes that the consequences of his actions do merit help from a set of prethought guidelines, and the second type of engineer doesn't realize it, but should.

Through discussion of the following central topics, I will describe the what, why, where, and how of the validation effort that the Environmental Sciences Division of Envirex is currently performing.

1. the purpose of the validation efforts,
2. why a workable set of guidelines is so desperately needed in industry today,
3. a description of the investigative approach used to validate the guidelines,

4. a brief description of the three types of industrial plants in which the evaluations are taking place, and
5. a closer examination of how two model parameters apply to one of the case histories.

I will then end my talk with some words of caution and optimism. I will try to pattern my comments like the proverbial bologna sandwich that one of my college professors explained how to use when evaluating someone: start off sweet, hit 'em hard with all the points to improve on, then wind up by telling him he's the best employee you've ever had.

The word "validation" can apply to two types of evaluations that are performed. First, a recirculation system that has been designed and installed is validated when a program is undertaken to prove that its performance meets design specifications. As outlined in the A. D. Little report, the important elements of this type of evaluation consist of testing the monitoring system and alarm, testing the failure response strategy, and recording the performance data. However, the second type of validation refers to a broader application of the guidelines, one in which the design criteria and model are used to help insure their usefulness before they are later applied in industry.

The idea of a validation effort first originated when it was realized that the development of a more useful set of guidelines could be enhanced if they were first put through a check. Therefore, this project was initiated to gather field data which would actually serve two purposes.

First, the results of these field evaluations would serve as practical examples of how the guidelines (and perhaps even the model) would actually apply. In addition to the documentation of the individual case histories, the second goal of the validation effort would be to make recommendations for changes or modifications of the guidelines as required at the conclusion of the industrial evaluations. I believe that this process, one of gathering data from field studies prior to final publication, is an important step in the development of documentation that is useful and will truly satisfy the needs of industry.

There is a pressing need for a set of properly validated design guidelines, chiefly for two reasons: to show plants how to decide upon and to safely execute a plan to recirculate; and to show plants that may have tried and failed where they went wrong. As the three examples showed earlier, some plants are willing to risk the health of the worker in order to reduce energy consumption to avoid future cutoffs, or perhaps to alleviate a serious financial burden. But plants ought to be more ready and willing to execute a proper design, installation, and operation of recirculation systems due to the possible legal implications they may be subject to if their actions are ever viewed as improper engineering practice. I believe this is a serious enough reason to do it right.

I would like to describe the approach that I have taken to validate the guidelines and criteria, then give a "status report" on the evaluations which are just underway. And since I have just completed the field phase of one of the evaluations, I will finish by showing how I have applied the various model parameters as outlined in the Arthur D. Little report.

The industries that were initially chosen to be evaluated had to satisfy certain criteria in order to be more representative of typical industrial situations. Ideally, they should represent industries that:

1. are widespread and employ a significant number of employees,
2. have an urgent need for energy conservation measures,
3. would provide a willingness and cooperation so necessary for a study of this type, and
4. have specific processes or areas that have a good potential for recirculation or that already have a recirculation system now operating which could be evaluated.

Furthermore, a diversity of contaminant types and hazards would be desirable in order to better check the guidelines under various conditions. As a result of numerous contacts with plants, three sites were selected which, I believe, satisfy the criteria as outlined above.

The evaluations that are now underway are located in a foundry, a woodworking plant, and a lead battery manufacturing facility.

Before I get into the individual case histories, let me first tell you about the two types of evaluations that are being performed. The first type, called a Phase I evaluation, is one where the following three steps occur:

1. a preliminary investigation,
2. field evaluations leading to a recirculation decision, and
3. system design and installation.

The second type of evaluation, called a Phase II evaluation, is one that is undertaken to evaluate a recirculation system that is already installed and operating. It consists of the following important elements:

1. preliminary investigation,
2. field sampling, and
3. a system evaluation.

The first site that I will describe is the woodworking plant. It is actually a furniture manufacturing facility that has a system operating where the exhaust from a baghouse returns directly to the plant area from which the air is locally exhausted. Since it represents an existing installation, only a Phase II evaluation will be conducted at this site. Because of the low toxic nature of the contaminant and the high efficiency of the dust collector, the system was designed to return the air directly without the aid of a secondary filter or automatic monitoring device. I was told during a preliminary visit that the method of monitoring the most probable type of failure--a bag breakage--is by means of visual observations by the workers located near the outlets of the return ducts. Although this method certainly lacks the sophistication of most monitoring strategies that have been proposed, a conscientious maintenance man assured me that it does work.

He explained that when the system was first installed, several bags broke in the first week because they had been installed improperly. Warnings by the

workers proved effective at that time toward recognition of that type of failure, and none have since occurred through its first year of operation.

The second industrial evaluation, which is just underway, involves a baghouse exhaust stream from a foundry cleaning room. Although three baghouses exhaust the various contaminant sources from within the surrounding plant area, one is undergoing evaluations to assess its recirculation potential because it is the newer and more efficient of the three. Although it currently exhausts three shot blasting operations which emit a heavier dust loading probably composed of a significant amount of particulates in the small size range, a scheme has been developed to identify those sources which may contribute lighter loadings composed of larger size particles. Eventually the ductwork may be rescrambled so that the sources that can be most efficiently controlled will be rerouted to the newest collector. A testing program would then follow to assess what additional collecting and/or monitoring may be required to insure a safe level of contaminants in the return exhaust stream.

In addition, attempts are being made to assess the best method and place in which to reintroduce the recirculated exhaust stream. Because the return air can be thought of as another "source" of contamination (even though small), other areas within the plant are being scrutinized as possible sites for the introduction of the return air, simply because the existing air quality level at these sites can better accommodate the addition of a contaminant source. I think this approach, one of investigating other areas within a plant in which the air is relatively clean or where the worker population is low or nonexistent, is a good approach for virtually any plant considering recirculation. As the authors of the Arthur D. Little report indicate, this scheme lowers the likelihood of exposure to a contaminated exhaust by delaying the exposure time after a failure sufficiently long enough for a proper system response to take effect.

Because this evaluation is not yet complete, a "status report" at this site is unfortunately somewhat premature. And although I have not gone far enough into the study to formulate a firm system schematic, I have seen other successful attempts to recirculate a silica-contaminated process exhaust. An approach used that has proved successful involves several important steps such as, but not limited to, the following:

1. carefully choosing the loading and size range of the exhaust;
2. utilizing a very efficient primary collector such as a baghouse;
3. utilizing a highly efficient secondary cloth filter coupled with pressure sensing switches or other monitoring systems to act in a fail-safe mode of action; and
4. recirculation of the effluent to a cleaner area of a plant, such as a storage area or a core room.

The third evaluation is one that may prove to be the most interesting and perhaps the most controversial. A prototype system was installed by a lead battery manufacturer to examine the feasibility of recirculating a process exhaust stream containing lead oxide particles from a machine that "stacks" lead battery plates. The plates actually are metal grids which have been coated with a dried lead oxide paste. A 1,500 ft<sup>3</sup>/min exhaust stream from the

"stacker" machine is directed to an air cleaning device which consists of two HEPA filters in series.

The exhaust air from the unit is then returned directly to a distribution air plenum above the work station. A little later in my presentation, I will discuss some of the advantages and disadvantages of this practice. But at this time, only a workplace evaluation has been made, and recent duct samples are now undergoing analysis. Nevertheless, I would like to discuss some observations that have been made up to this point in time.

1. My approach in the preliminary evaluations is to quantify all of the necessary parameters called for by the Arthur D. Little model so that predicted levels might be compared with measured values. So far, in-plant measurements show acceptable contaminant levels in the breathing zone of the worker and the surrounding plant area.
2. During 5 months of operation, the company has monitored the performance of the collector, and their evaluations show favorable results. Frequent lead-in-air measurements by the company have shown that the air quality has stayed the same after the system was installed. Regularly taken operator blood lead sample levels have shown no increase due to recirculation.
3. A pressure switch-type monitoring method is currently employed that will immediately shut down the operation or bypass the air in the event of a failure of the first HEPA filter. In addition, a monitoring instrument which will continuously sample the return air duct has been evaluated and its use is envisioned in the final design. The monitor operates by means of a sensitive photometer, and is capable of detecting particulate concentrations down to  $0.001 \text{ mg/m}^3$ . This device would be set at a specified trigger level, and in the event that excessive levels are detected, the system would automatically shut down or bypass the exhaust air.

Although investigations of the prototype system are not yet complete, preliminary results thus far are very encouraging.

Now, I would like to examine how two of the model parameters apply to one of the industrial situations that I have just explained. Of all the model parameters that must be determined, the three which require estimation are  $K_r$ ,  $K_{bz}$ , and  $f$ .

The A. D. Little report defines " $K_r$ " as a number between 0 and 1 which estimates the contribution of the return air to the local exhaust system. It may be directly calculated, or at least have its limits directly computed. " $K_{bz}$ " is also a number between 0 and 1 which estimates the contribution of the return air to the breathing zone. It usually cannot be directly computed; however, a conservative value can be easily estimated. The third factor for which a value must be assigned is " $f$ ". This factor becomes necessary when predicting what the breathing zone concentration will be when a worker is standing within a strong flow field near the openings of large, local exhaust hoods. And since there are no such flow fields at the sites that are being evaluated, I will not discuss the parameter " $f$ " any further. " $K_r$ " and " $K_{bz}$ " need to be more carefully considered when choosing the important elements of a configuration, such as the location of the return airstream. By doing this,

the adverse effects of reintroducing a somewhat contaminated return airstream can be minimized when these values are kept as low as possible. When  $K_r$  is low, this implies that the amount of return air flowing into the recirculated local exhaust is minimized, as typified by a return air duct that is located in a remote area (a storage room or a compressor room, for example). In addition, the choice of a remote site would also reduce the amount of return air flowing through the employees' breathing zone, thus reducing the estimated value for  $K_{bz}$ .

An opposite effect should be seen in the lead battery plant where the return air is ducted back into the worker's breathing zone through an overhead return air plenum. However, this system configuration only affects the calculated value for  $K_{bz}$ , and not  $K_r$ , although both values are estimated to be 1.0. The effect of  $K_r$ , the factor that describes how much of the air flowing into the recirculated local exhaust is return air, does not influence the final calculated value for the return air concentration, because of the high overall system efficiency of the double HEPA filter (one HEPA filter is rated at 99.97 percent efficient for particles greater than  $3 \mu\text{m}$ ), and because of the low contaminant concentration in the fresh makeup air (measured at  $0.002 \text{ mg/m}^3$ ). No matter what value is used for  $K_r$ , the calculated value of the return air concentration remains essentially the same.

The subject report clearly illustrates that the predicted breathing zone concentration is sensitive to effects of the return air contribution factor, ( $K_{bz}$ ) and the return air concentration ( $C_r$ ). It shows that for given values of  $C_r$ , the predicted breathing zone concentration values are at a maximum value when  $K_{bz} = 1.0$ . This point, together with the possible reduced margin of safety in the event of a system failure, emphasizes the undesirability of returning the air directly to the worker's breathing zone, as a quick calculation would show that the predicted breathing zone concentrations could be dramatically reduced merely by directing the air from workers that may be affected.

However, it could be argued that to propose a guideline that says to never direct the air back toward an employee may be too severe. "Never" is a long time. In the case of the lead operation, preliminary evaluations show three positive effects of the overhead return air plenum. First, the return air concentration is so low that the worker is actually "bathed" in a shroud of air as clean as or cleaner than the surrounding background air. Second, the return air from the overhead plenum acts as the "push" component of a push-pull system that helps keep contaminants generated from that operation away from the breathing zone of the worker. Third, the "push air" actually improves the collection efficiency of the exhaust hoods on the machine as evidenced by increased hood face velocities after recirculation was implemented.

In view of the highly efficient filtering system and the two types of monitoring systems previously discussed, frankly I am not sure that the approach at the battery plant isn't a good one. To assume that every system will eventually fail may be one approach toward insuring that some fail-safe mode of

action be considered, but I believe that a consideration of the various probabilities of failure is also an important aspect when discussing a monitoring strategy.

In summary, I have stated that the purpose of my evaluation was to check the workability of the guidelines through the evaluations of existing and proposed industrial situations. I emphasized that an urgent need exists for a set of useful guidelines, and then I explained how the investigative approach was formulated to include a diverse scope of industries and contaminant types for study. Finally, I briefly examined some of the model parameters as they might apply to one of the industrial situations.

I would like to leave you with some preliminary impressions and reservations that I have on recirculation in general and on the guidelines in particular. Although some of these points have been covered before, I believe that they deserve a quick reemphasis.

First of all, I applaud the inroads that the authors have made to give in-plant ventilation studies a rational approach or, perhaps more importantly, a workable mechanism for examining the various economic trade-offs and choices available to the designer. But I also worry about several things.

First, the use of any model implies a number of inherent assumptions that were explained quite well in the document. But I still wonder how such assumptions as steady state, nonfluctuating processes, perfect mixing, balanced systems, etc., will affect the accuracy of the model's predictions.

Second, the probability of a system failing in many cases is more dependent on what happens after the design is put into operation. Improper maintenance will probably be the culprit when a system fails, not the design. Enforcement of a system's properly executed maintenance plan is the key to the continued existence of the recirculation concept.

Third, I am convinced that only a certain number of companies or individuals are in a position to properly use this document. The engineering consultant and the staff of larger companies who have developed the environmental health engineering and industrial hygiene expertise will derive the most benefits from this work. Many others will probably just be confused by the model. However, the guidelines themselves are needed at this point in the development of the recirculation concept, and I believe that the results of the A. D. Little work will provide a useful guide for designers of such systems. I also hope that the results of the various validation efforts will help bridge the gap between the generalized approach as presented, and practical design procedures as needed by the engineering designer today.

## DISCUSSION

MR. JEFF GREEN (Kohler Co., Kohler, Wisconsin): Larry, did you get a chance to look into the cost of these systems, particularly the one on the recirculation of lead, initial cost versus initial cost of traditional system, the long term cost, annual cost, recovery, and so forth?

MR. BULLOCK: Actually, I'm not quite that far in the evaluation; I'm still making measurements in the field phase of the evaluations. I will be looking at the cost a little later on, so that will be in the report.

MR. BRUCE MENKEL (Bruce Menkel Consulting Engineers, Dayton, Ohio): You mentioned in the talk that your validation is going to be on the wood-working, foundry, and battery manufacturing plants. Is that the extent of your contact?

MR. BULLOCK: That is correct. I am quite sure NIOSH will be funding other validation efforts than those three industries. There are three additional industries, I believe a rubber facility, metal grinding. . . .

CHAIRMAN HUGHES: Chrome plating.

MR. MENKEL: That is my second question. Mr. Hughes, you mentioned that yesterday. This is another contract, separate from this?

CHAIRMAN HUGHES: Yes, it is another contract with Arthur D. Little.

MR. MENKEL: Is that contract in effect now?

CHAIRMAN HUGHES: It is in effect. It is in its initial stages. It will be running concurrently with the Envirex work.

MR. JOHN ASHE (American Air Filter, Louisville, Kentucky): Was there a bypass on that lead system?

MR. BULLOCK: Actually, no. This is a prototype system, and at the present time the system is hooked up to the original baghouse and the experimental unit, so if something happens they can divert it to the baghouse. In the following applications, I believe that they intend to put some type of bypass on it so they won't have to shut down the operation in the event of failure.

MR. ASHE: In my experience, this particular type of device exhibits a high pressure problem, and it certainly could build up fast with the resulting drop of capacity, which would affect the performance. Was that considered? Are you testing over time?

MR. BULLOCK: Well, the company has been performing evaluations for a period of 5 months. We are not yet done with the evaluations, and they are monitoring the pressure drop daily across the first filter. They also are shaking the device manually at this time, and very closely monitoring the pressure drop across the first filter. They are concerned with the life of the filter, and thus far the evaluations have shown favorable results.

MR. ASHE: The end result of that pressure drop is an effect on flow, presuming you don't have any other volume control device in the system, such as dampers, variable stand, and so forth, so you're saying the flow remains reasonably constant?

MR. BULLOCK: Right. What they hope is that the baseline pressure level that they measure returns every time the filter is cleaned. Up to now, it has gone up just slightly. If this thing went up dramatically, then . . . .

MR. ASHE: This is, in effect, acting like a baghouse?

MR. BULLOCK: Yes.

MR. ASHE: Cleaning frequently enough?

MR. BULLOCK: Yes.

MR. STRICOFF: In light of the recirculation and the poorly designed systems, as you described at the beginning of your talk, would you advocate the development of guidelines that a small company with any expertise in ventilation engineering could use, or do you think it is a better idea to try to encourage those people to seek outside help before they go to recirculation?

MR. BULLOCK: That is a good question. In theory, guidelines are preferable; however, I believe that at this time only certain companies should attempt recirculation, until some systems have been demonstrated and there are some data available from them. For example, in a baghouse in a foundry cleaning room you know enough about all types of cleaning rooms to be confident enough of what your particle size distribution is and basically what type of exhaust you're dealing with. I think some model-- I hate to say a simple model--but schematic setup that would give the company an approach to start with, some type of cleaner followed by a filter can be developed later on simply by the process when you know what you're dealing with. But at this point in time I don't think anyone has a very good handle on exactly what the characteristics are of these return streams. A lot of small companies don't know enough right now, don't have the expertise to evaluate these things, so I think smaller companies would probably benefit from consulting firms or other individuals who can help them.

CHAIRMAN HUGHES: I personally don't think you should restrict recirculation only to large companies. Any company, small or large, that has an energy problem should, if recirculation is a proper technique and is chosen as good or better than some of the other energy-saving techniques, attempt it. What we are trying to emphasize with the work that we're doing, is that you must have qualified people making the analyses and the decisions with regard to recirculation, because of the fact that it does offer a greater potential for worker health problems. Some of the smaller companies, due to their organizational structure, may not have industrial hygienists or design engineers whose sole purpose it is to look at these things. They should seek help, which they do now. So I don't think you should restrict recirculation. It's just that proper people with the training and expertise to make the decision should be the ones that design the system and make the analysis.

MR. H. S. PEI (Bolt, Beranek and Newman, Cambridge, Massachusetts): In your talk you mentioned that you had some failure response data. I'm wondering, can you give us more description of what you mean in general, or especially regarding the three types of operation you just mentioned?

MR. BULLOCK: I glossed over the idea of failure response. I think I mentioned it in several spots. I was talking in terms of the two factors,  $K_{bz}$  and  $K_r$ . When the practice of returning the air directly to the worker is used, as in the case of the lead plant, the time it takes to implement a failure response strategy must be considered, because the effect upon the worker is immediate. That is one type of failure response rate we spoke of.

Arthur D. Little has a chapter devoted to validation of the guidelines, in which they emphasize that after you have the system installed you should do a number of things to validate the system, one of which is to simulate failure type of activity or failure mode. They don't say expose all your employees to high levels to do this. They say lower the trigger level on your monitor to some level that is acceptable, and then try to simulate a failure mode. I think this is a pretty good approach, just to check the system out.

MR. PEI: I agree. Are you going to have any field data to simulate the failures in case, for example, when an air cleaner or bag is broken, but use the samples to show how the failure occurred, and what would be the levels in the pass?

MR. BULLOCK: I haven't discussed this with the companies I'm dealing with, but I think that is one thing which I plan to do, to try to set these trigger levels lower and try to simulate a response. I think it is a good idea to run the system through an actual check.

MR. PEI: Even though you have your bypass, or you have a lot of safety means, we still would like to see some data or any kind of simulation to show us the levels in the plant in case all the safety ways also fail.

MR. BULLOCK: I also share your concern for a need for that type of data, and I hope to be able to give it to you in my evaluations.

MR. TOM BLOOM (NIOSH, Cincinnati, Ohio): Have you uncovered any advantages or disadvantages of situating the air cleaner inside or outside the plant?

MR. BULLOCK: You're referring to model approach where you have the air cleaner sitting at the operation versus a kind of retrofit baghouse type of thing?

MR. BLOOM: I think in your early slides you showed the baghouse and the flow indication, and in the subsequent slides you had the device 2 or 3 feet from the work station, some distance. One was inside the plant and one was outside the plant.

MR. BULLOCK: That is a little beyond the scope of my work, except I can point out some of the obvious things that happen. If you collect inside, it

helps monitor the temperature drops due to the system and so on. I think a more important issue might be whether or not a company should go with a modular type of system, such as the one in the lead plant, or whether they should try to go in and take a baghouse and try to retrofit it with some type of secondary filter or some scheme to reduce its exposure to possibly recirculate that exhaust, and that is something I've been grappling with. The operational characteristics of a model unit are much better than trying to retrofit a baghouse, because if that system breaks down you're not penalized, say, as in a baghouse breakdown. It is more isolated. The air is returned to the area that is exhausted, so we have a more isolated condition. On the other hand, because the baghouses are already there, you don't have to go out and purchase new collectors. And secondly, you've got a large quantity of air which you can distribute any way you would like. Many problems in plants today in terms of ventilation are because the air is not returned to the areas in which it is needed most. Some type of air makeup unit along the wall to more or less create an actual ventilation pattern through the area can go very far to help remove contaminants. So there is disadvantage to both types of approaches.

MR. ROBERT POTOKAR (General Motors, Warren, Michigan): On the lead recirculation system, what is the air flow of this pilot system? What is this monitor that you've mentioned? Can you describe that in a little more detail?

MR. BULLOCK: Surely. The system originally had design capacity of 2,000 ft<sup>3</sup>/min. The company, because they had modified the installation to suit their own needs, put in the insulated ductwork. They added some things that they thought were desirable. For example, the workers complained that it was too warm in the summertime. There was actually temperature increase through the system, so they installed a series of pipes to help cool the exhaust stream down. This is something they are trying. Because of these added conditions, the flow is approximately 1,500 ft<sup>3</sup>/min, and it varies over the cleaning cycle. The monitoring device is actually a nephelometer that the gentleman spoke of yesterday as being such a good device. Their instrument, which they had borrowed from the company, was actually performing the same function as the one they would actually use, and they had a tape recording device, a strip chart record, to record the levels which it detected.

## AIR RECIRCULATION FROM FOUNDRY OPERATIONS

Robert W. Potokar\*

### Abstract

*The American Foundrymen's Society is an organization sponsored by private industry to develop and communicate technology critical to the foundry industry. Foundries, like other segments of the business community, have become increasingly concerned with energy availability and efficient use of this increasingly scarce resource. To help answer this need, the AFS has formed The Task Force on Energy Conservation Through Exhaust Recirculation. The goal of this group is to fully demonstrate air recirculation from foundry process exhaust. This paper will describe the present state-of-the-art of foundry air recirculation and describe the engineering effort presently being done aiming at installation of properly engineered air recirculation systems.*

To many laymen and engineers alike, it is surprising to find that one of the major uses of energy by all foundries is for heating and distributing makeup air. On a yearly basis, heating, ventilation, and air conditioning (HVAC) energy usage averages over 15 percent of the total energy used by an iron foundry, and during a winter month this percentage may exceed 50 percent. The amount of energy going to HVAC has accelerated in recent years because of increasing pressure from the Occupational Safety and Health Administration (OSHA) and from employees to meet contaminant standards and improve worker comfort. The major efforts in this regard were made before the energy crisis; therefore, little attention was paid to air recirculation or other heat recovery means. Now because of high energy costs, better equipment, improved hood design, less toxic resins, and improved maintenance practice, the time has come to make a serious effort in air recirculation.

First, why air recirculation as an energy conservation means? The majority of the air exhausted from foundries is near ambient temperature. The volume may be in the order of 10 million ft<sup>3</sup>/min in some of the large automotive casting facilities. The fact that we are dealing with large air volumes with low temperature makes the cost effectiveness of heat recovery marginal. Also, heat recovery equipment--heat wheels, heat pipes, air-to-air heat exchangers, etc--only offers a 40 to 60 percent Btu recovery potential, whereby air recirculation approaches 100 percent recovery of the energy of the airstream.

To help coordinate the metal casting industry's efforts on air recirculation, the American Foundrymen's Society's (AFS) Environmental Affairs Director,

---

\*Senior Project Engineering, General Motors Corporation, Warren, Michigan.

William Huelsen, acted as a catalyst to organize some of the industry's leading ventilation engineers and industrial hygienists into the AFS Task Force for Energy Conservation Through Exhaust Recirculation. For those not familiar with AFS, it is an engineering society sponsored by private industry for the purpose of communicating and advancing technology critical to the metal casting industry. The Recirculation Committee has been active since January 1977. The committee's first decision was to focus its efforts on reintroduction of exhaust air into the workplace to conserve energy. We would not consider utilization of dirty exhaust in other processes or the use of unheated makeup air around ventilation hoods to provide the needed draft and exhaust volume. Also, because of reasons previously mentioned, and the fact that suppliers, engineers, and engineering societies are addressing indirect heat recovery, these areas would not be considered.

The day has now come when the ventilation engineer can supersede production, and everything should be done to reduce exhaust from buildings. However, throughout the foundry industry, there has been a minimum of engineering idea exchange on air recirculation and a lack of coordinated effort by industry, government, and equipment suppliers. Hopefully, this task force can coordinate a research and development (R & D) effort and influence suppliers to provide air filtration and monitoring equipment to meet the requirements of air recirculation.

Foundries, as all complex multiprocess facilities, have numerous exhaust streams, all with different temperatures and contaminants. Exhaust emanates from the mold room, core room, shakeout, sand handling systems, cleaning room, and other processes. To obtain a background on present recirculation installations and past attempts, a questionnaire was sent to 3,500 industry executives in February 1977. Based on this survey and on the fact that the exhaust from the cleaning room should have no products of combustion, it was decided that the first process to be fully investigated for recirculation would be the cleaning room.

The cleaning room operations are a conglomerate of processes such as grinding and deburring. They employ the largest percentage of people and run production during periods when other heat-producing operations of the foundry would not be able to supply heat, necessitating the use of outside energy or makeup to replenish exhaust. Generally, the exhaust volume is about 20 percent of the total foundry exhaust.

Of the 3,500 questionnaires sent, a little over 100 were completed and returned; of these, 47 admitted to either having or having tried recirculation systems. The majority doing so were from cleaning room exhaust. No installation was found that we felt represented good engineering practice, which is poorly specified air filtration equipment followed by a return air monitoring system and a bypass to atmosphere in case of efficiency problems. Some of the newer recirculation installations from blast cleaning in the cleaning room are using opacity meters to monitor the cleanliness of the exhaust before return to the work space. However, the sensitivity of opacity meters is quite limited. It would require a path length of 10 ft between the light source and sensor to enable a 1 percent opacity change to relate to a rise in particulate concentration from  $1 \text{ mg/m}^3$  to  $2 \text{ mg/m}^3$ . Because opacity is an optical measurement, it is dependent on particle size distribution and reflectivity characteristics of

the particulates in the gas stream. So, to use an opacity meter, the instrument has to be calibrated versus in-stack mass measurements and the particle characteristics must remain constant over all conditions.

Getting back to the results of the survey, it was found that some foundries have attempted to recirculate from different operations without success. In one case, the recirculation was in operation for a year before it was discovered that the concentration of free silica in the breathing zone was too high due to the recirculation. From this background, it was decided that a demonstration recirculation system be installed on the cleaning room exhaust following these steps: (1) emission characterization, (2) filtration equipment specification, (3) monitoring equipment specification, (4) integration of a complete system, (5) building and installation, and (6) performance testing. This type of engineering sequence would be recommended for all recirculation system installations even if a similar process presently had a system which could be copied.

The AFS research funds are being used to accomplish the first task of emissions analysis. Five foundries have agreed to participate and provide required test ports and access scaffolding. The test will be run in the following manner and the data will not be identified as to their source except to the committee.

Simultaneous inlet and outlet process emission samples of one cleaning room exhaust stack and collector discharge are to be performed in duplicate at each of five foundries. The facilities were selected on the basis of providing a cross section of iron foundries from the large, highly automated to the small operation and a variety of ventilation and collection systems. Each emissions sample is to include all of the following parameters and be performed in the prescribed manner:

<u>Parameter</u>	<u>Method</u>
Total particulate concentration and stack conditions, temperature, velocity, etc.	EPA Methods 1-5
Particle size distribution	In-stack cascade impaction
Carbon monoxide	Wet chemistry
Phenols	Wet impingement, distillation and gas chromatography
Formaldehyde	Wet chemistry
Particulate chemical analysis on fraction $\geq 5 \mu\text{m}$ and $< 5 \mu\text{m}$	
a. Free silica	X-ray diffraction
b. Cristobalite	"
c. Quartz	"
d. Tridymite	"

e. Cu	Atomic absorption spectrophotometry
f. Zn	"
g. Fe	"
h. Organics	Hexane extraction
i. Total inorganics	Difference

The emissions testing is to be completed by November 1, 1977. Following this, a specification will be written for the filtration and monitoring equipment. If these specs can be met by suppliers, a foundry will be sought to install the demonstration system. If equipment development is required, AFS will seek the best route to meet the need. The maximum contaminant concentration in the recirculation airstream is targeted at 10 percent of threshold limit value (TLV). Of course, by using the "Guidelines for the Recirculation of Industrial Exhaust" (ref. 1), this limit may change depending on the actual facility where the equipment is to be installed. We hope that by the April 1978 Casting Congress Meeting, we can make a complete report on this project and then move on to other process exhausts.

#### REFERENCE

1. Arthur D. Little, Inc., "Guidelines for the Recirculation of Industrial Exhaust," Draft Report, Contract No. 210-76-0129, July 1977.

#### DISCUSSION

MR. JOHN TALTY (NIOSH, Cincinnati, Ohio): Are the task force and the demonstration projects going to be addressing operation maintenance requirements of the systems that should be installed, because I think that is a very important aspect, and are they going to be public?

MR. POTOKAR: Yes, certainly. One of the things we would tend to get upset by is the kind of guidelines that are often put out by NIOSH and other government agencies, which give you the very broad concept of what should be done, but when it comes down to how the engineer in the plant should do it and what he has to take into consideration, he is really lost. What we want to do is provide a total system, and try to demonstrate what type of cost, capital and maintenance might be involved so that he would know what to look out for.

MR. JEFF GREEN (Kohler Co., Kohler, Wisconsin): Have you conducted any cost analyses? When do you expect to see your capital recovery?

MR. POTOKAR: You can't do a cost analysis until you know what kind of equipment you need. As soon as the emissions analysis is completed, the next step is to put that into a bid package and go out to vendors and find out what it is going to cost.

MR. GREEN: You haven't done your preliminary?

MR. POTOKAR: Yes, we've done evaluations ourselves. As a committee we have put together a cost evaluation, such as how much energy is used by foundries in different processes, how much is going out the door, that type of thing, so we know the potential is there.

MR. GREEN: You have no preliminary estimates to, say, 5 years for capital recovery?

MR. POTOKAR: Typical ball park figure for the cost of recirculating makeup air is 40 cents per cfm per year, which means if you're blowing the cfm out every day of the year it is going to cost you 40 cents in energy to put that back, so with any type of recirculation system you're not going to get it for a dollar a cfm. You're talking about a minimum of a 3-year payback, and at one time, if it didn't mean a 2-year payback, industries didn't consider it. Now that energy is a big factor, if you're going to shut down during the winter, you had better start considering 5-year paybacks and 10-year paybacks.

MR. PETER PULLEN (Rio Algom Limited, Toronto, Canada): We are looking at energy conservation, and I'm just wondering whether we shouldn't also look at the other end of the cycle, that probably we should evaluate the potential of reducing the quantity of air we are handling. In other words, tighten up on our design criteria to reduce the air and yet still get the same control over our contaminants. I'm thinking particularly of dust control.

MR. POTOKAR: The type of work we are doing, AFS or NIOSH work, is best done on an individual plant basis, so that if it requires a high velocity, low-volume system, it's up to the working engineer to try to put that in. If it needs a process change to cut down the amount of cfm, still it's up to those at the individual plant level to try to do that. You can't address every particular situation, but certainly before you ever attempt recirculation, the first thing to do is make sure you are using the right amount of air to begin with. There has been a lot of talk about further contaminating the work environment. We feel, as recirculation becomes more feasible, it may actually be the opposite way. Because of recirculation and because you're recovering energy, you can now afford more face velocity at the hood, thereby removing the contaminant more effectively from the worker's breathing zone. Therefore, across the board you may come up with lower levels at the worker's breathing zone.



## A CONSULTANT'S VIEW ON AIR RECIRCULATION

George M. Hama\*

### Abstract

*The viewpoint of industry over the past years has been influenced by State and local government regulations restricting recirculation to nuisance dusts. This is probably the present viewpoint as industry is not aware, for the most part, of the newer, less restrictive approach.*

*Industry is interested in recirculation from the standpoint of fuel saving and because of concern of possible restriction on fuel use, which would restrict operations and future expansions.*

*Worker contaminant exposures determined by theoretical models will not be satisfactory as determined on the basis of approaching Threshold Limit Values.*

*Industry needs help on how to apply recirculation to specific processes and operations, other than listings of design factors. The design factors, however, are needed.*

My original assignment was to discuss "An Industrial View on Air Recirculation." When I looked at the program just before coming out here, I found that the title had been changed to "A Consultant's View on Air Recirculation." However, I will stay with my original assignment for most of my discussion and add at the end some discussion on a consultant's viewpoint.

In considering the industrial view on recirculation, I would like to go back over the years and review the type of thinking with which some of us influenced industry.

My first experience with industry was a number of years ago when I first got out of school. I was hired by a mining company with mining operations--primary and secondary crushing plants--to do something about the dust; they apparently had discovered that they had a great many silicosis cases. I designed local exhaust dust control systems, such as they were, for the crushing, conveying, and screening equipment. I remember wondering if I should dare to put effective dust control equipment on the exhaust of the primary crusher. Well, I didn't. Instead, I used a cyclone collector. Makeup air and heating replacement air were not thought of by management, not that it

---

\*Consultant, Huntington Woods, Michigan.

wasn't cold enough (this was in the Adirondack mountains of New York) and I knew enough not to suggest it if I wanted to keep my job. However, interestingly enough, we did have one recirculation job--mining dust.

Mining dust exposure is very heavy from dry drilling hard rock. A shift was made to wet drilling, but that wasn't exactly pleasant. Miners often came out cold, wet, and muddy. Some relatives of the mine manager conceived the idea of using an air ejector and exhausting air around the drill bit with a little exhaust hood called a "Kelly Trap." The dust-laden air went into a cyclone collector which, in turn, discharged the exhaust air into the mine. Recirculation took place because it was hardly practical to discharge air 4,000 ft below ground to the outdoors.

My next job was with a very active governmental industrial hygiene bureau. During my period of work there, two events occurred that influenced the thinking of industry. One was the writing and publishing of the Industrial Ventilation Manual (ref. 1), the other was the start of the Michigan Industrial Ventilation Conference. I remember my experience as an instructor at the early conferences. Most of us were learning with our students. Sometime during the early conferences, "makeup" air became a popular phrase, and we pounded it into the students. Most places had no replacement air, and we found that it also cost money to heat air. Industry began taking on the problem with us and makeup air entered into their plans. It was slow. Even today there are very few places that have enough replacement air.

During the 32 years that I was with the government bureau, a few recirculation units came into use. Several unit collectors appeared with fans and dust collectors. These were of small capacity and were used for nuisance dust grinding operations, tool grinding, jewelry grinding, and dental appliance grinding. A little later, some large units of the wet collector type appeared in the auto industry. These were up to 15,000 ft<sup>3</sup>/min capacity. Oil mist collectors of the electrostatic type also appeared. A number of these were set up for convenience as recirculation collectors. This concerned us, as we felt that oil mist was more than a nuisance material. There was some inference of it causing lipoid pneumonia, which later appeared to be unfounded. A plating tank mist scrubber appeared that was tried on some acid pickling baths. Although the discharge concentration did not exceed the threshold limit value, something irritating the discharge caused us to turn it down. Finally, as I recall, a pharmaceutical company presented a plan for recirculation of certain pharmaceutical dusts. The system was well-designed and had an efficient fabric collector. After much consideration, it was decided, as a matter of policy, to not allow the recirculation of toxic contaminants and regulations were formulated regarding recirculation. At about the same time, several other governmental agencies were also setting up regulations. Finally, the Industrial Ventilation Manual published guidelines. I do not want to take credit for what appeared in early editions of the Industrial Ventilation Manual, as it reflected the opinions of several government agencies as well as our regulations. The pertinent part reads as follows:

Recirculation Not Recommended: It is the general policy of all official health agencies not to recommend recirculation of exhaust air if the contaminant is a material which may have a definite effect on the health of the worker. The reasons are as follows:

1. Many types of air cleaners do not collect toxic contaminants efficiently enough to remove the health hazard.
2. Poor maintenance of the air cleaner would result in deliberate return of the highly contaminated air to the breathing zone of workers . . .

Recirculation accepted some types of air contaminants, particularly dusts regarded as nuisances rather than true health hazards. For exhaust systems handling these materials, recirculation may be accepted. No blanket acceptances can be made . . . . (ref. 1)

Inasmuch as the Industrial Ventilation Manual has worldwide acceptance as an authority and is also used as a text at the Michigan Industrial Ventilation Conference and a number of similar conferences, I believe the above policy has wide coverage and has influenced the thinking of industry over the years to accept the position that only nuisance contaminants can be recirculated. In my experience with the governmental health agency, several acceptable proposals for recirculation were made and turned down. One was a recovery unit for perchlorethylene used in dry cleaning. A test on the emissions showed a low concentration. I think it could easily have been made fail-safe, but due to the agency's regulation, it was flatly turned down. I think this policy has affected the industrial viewpoint to accept, in most cases without murmuring, a regulation to limit recirculation.

At the moment, most industrial personnel are not aware of the fact that a new look has been taken at recirculation and that it is being considered on a wider basis. I believe the 1974, 13th edition of the Industrial Ventilation Manual was the first edition to suggest that recirculation can be permitted for other than nuisance materials. There has been some repercussion to this, but not a great deal. It appears that a great many persons do not read the fine print in this book and are not aware of this change. To help industry, there may be a need to approach Federal, State, and local agencies in such a way that they will be open-minded in considering recirculation.

As consultant to the contract group developing criteria for the recirculation of industrial exhaust air, I had the opportunity to call several industries to determine if they were willing to assist the group in allowing them to look at processes and exhaust ventilation systems in view of considering such operations for recirculation. With one exception, the industries contacted were willing to cooperate and also were willing to allow field measurements and air determinations. In a number of cases, but not all, certain industries would even allow a private research group to enter their premises.

Some of the larger industries have energy conservation departments. Others are working directly with plant engineering departments in their energy conservation efforts.

Some of the reasons for the consideration of recirculation by these groups are as follows:

1. With escalating fuel and power costs, there is a need to reduce the high cost of air conditioning and heating large volumes of makeup air. As one representative of an energy conservation department

stated, "When I look at all the air we are exhausting, this looks like the place to begin to save energy." It is not unusual in the auto industry to exhaust over one million ft<sup>3</sup>/min in one building.

2. A fear or concern that fuel (gas or oil) will be restricted. As one plant engineer stated, "We believe we can get the same quota of gas that we got this year for next year. We are not sure if this quota can be increased. We intend to put in new heat treatment furnaces that will require more fuel and we believe we can obtain additional fuel to do this through recirculation."

Normally, if recirculation is applied to an existing exhaust system and no hood design changes are made, it is expected that the worker's exposure level will increase. How much increase can we allow? It sometimes appears attractive to persons making theoretical considerations to allow up to the Threshold Limit Value (TLV). I do not believe industry, in most cases, can work with this. I know of plants with both welding fume exposures and grinding dust exposures where the measured exposure values are only a small fraction of the TLV. Management in both cases is afraid to reduce airflows to save energy because they feel labor troubles will result. Certain existing levels of exposure cannot be increased without a challenge from labor.

If industry is to be given guidelines and assistance in recirculation of air, there is a need for more than a listing of contaminants that can be recirculated, a cataloging of various types of air cleaners, a summary of design features of monitoring equipment, and a model for recirculation. All this information is useful and basic, but more practical working information is needed. The approach that appears most practical is the preparation of workable methods of design for specific operations or processes such as plating, welding, woodworking, grinding, etc. An example of this, in another field, is the Air Pollution Engineering Manual (ref. 2), put out by a government agency. Presented in its guidelines are practical methods of control applied in some detail to specific processes and industries.

The following request I recently received from industry illustrates the practical information needed:

Prepare a study to determine the technical and economic feasibility of recirculating welding fumes. The study shall include:

1. analysis of the air contaminants encountered,
2. recommendations of continuous air-monitoring equipment,
3. recommendations of the appropriate air-cleaning devices,
4. cost- and energy-saving estimates for each system, and
5. preparation of a design guide for a prototype system that proves to be most economically feasible,

There is currently a need for information on specific monitoring of alert alarm systems for recirculation. There is a need for factual information on efficiencies of air cleaning equipment as applied to specific operational contaminants. If we are presenting to management models for recirculation based on efficiencies of collectors and fail-safe alert alarm monitors and controls, there is a need for equipment manufacturers to furnish this material. Finally, the recirculation design models must be applied to existing

control systems now operating with outdoor discharge to prove that such systems are workable and economically feasible.

The economic feasibility is a factor that industry will probably consider very carefully. Currently, the cost of recirculation systems of fail-safe design is high. Monitoring, alert control equipment is high in cost and possibly will be until simplified production equipment is available. In systems where, due to lack of space, the air cleaning equipment is placed out of doors a distance from the process, heat losses occur and high static pressures in the system require high power inputs into the fan motor. When these factors are balanced against heating cost savings in makeup air, there may be very little advantage.

I have up to this point, attempted to present considerations that enter into the industrial viewpoint from my own experience. Since the final title of this paper has been changed to "A Consultant's View on Air Recirculation," I feel obligated to add a few comments on what might be a consultant's view.

Since current recirculation practices may involve material that could have adverse health effects rather than just nuisance considerations, I believe consultants, especially those with some industrial hygiene experience, will tend to "play it safe." For example, if lead fumes were the contaminant, and if an electrostatic precipitator with several passes of high efficiency were used, I would back it with high-efficiency filtration. Electrostatics do lose efficiency through insulator failure and when they do, unsafe concentrations may discharge. Using a different concept of cleaning such as filtration, which apart from filter breaks increases in efficiency with use, may give an additional measure of safety in addition to the monitor safeguard.

A consultant will need to consider not only one contaminant but contamination from all processes and operations. For example, in recirculation of welding fumes by means of suitable air cleaning devices there will be a trend to save energy by reducing makeup air. When this is done, certain operations, such as the operations of propane-fueled lift trucks, need to be considered. In this instance, if insufficient dilution air is not provided, an unsafe carbon monoxide exposure will result.

As a consultant, I intend to avoid using monitoring devices that require a constant laboratory service although there will be many of these devices proposed. Most industries do not have full-time personnel available to service technical instruments. For one monitoring operation, I have selected an instrument used by an air pollution bureau for several years which requires very little maintenance service.

Certain economic factors will need to be considered. If the contaminant is collected wet and there are no plant wet waste treatment facilities, the cost for air cleaning will be high. If high static pressure collectors are used, the electric power costs will be high and this will need to be compared with heat savings costs. Equipment that requires maintenance with shutdown periods may not be economically feasible. There will be a need to calculate maintenance labor costs to determine actual savings.

Although I was not here yesterday, I am familiar with the criteria development material presented by John Hagopian and Scott Stricoff of A. D. Little, Inc. I have looked over their model and believe it can be applied practically to simple exhaust and makeup air systems. On large, complex systems with multiple exhaust and makeup systems, I would have difficulty applying model equations and feeling confident that I was getting the right answer. For example, I am currently working on a building with a large floor area and a volume of 187,000,000 ft<sup>3</sup>, with 35 separate exhaust systems and 38 makeup units distributed throughout the building, and supplying about 2 million ft<sup>3</sup>/min. We are starting with a few exhaust systems and converting them to recirculation systems and possibly we will reduce the makeup correspondingly. It seems to me that to predict the breathing zone steady-state condition (if it is reached), there may be a need to consider local exhaust and makeup air in certain small areas rather than the plant as a whole. There is undoubtedly a need for further studies on recirculation involving actual plant conditions before and after recirculation. The work by A. D. Little, Inc., appears to be a valuable start for such a study.

#### REFERENCES

1. Industrial Ventilation Manual, 11th edition, American Conference of Governmental Industrial Hygienists, Committee on Industrial Ventilation, P.O. Box 16153, Lansing, Michigan, 1951, pp. 5-7.
2. U.S. Department of Health, Education, and Welfare, Air Pollution Engineering Manual, Public Health Service, National Center for Air Pollution Control, Cincinnati, Ohio, 1967.

## AIR RECIRCULATION PRACTICES AND RESEARCH IN SWEDEN

Lars Olander\*

### Abstract

*The current Swedish practices on air recirculation are based partly on regulations for office buildings and partly on old regulations for hazardous industrial dusts. There are no general regulations for industrial air recirculation. The Department of Occupational Health (corresponding approximately to NIOSH) of the Swedish National Board of Occupational Safety and Health (corresponding approximately to OSHA) is investigating what factors to be considered when writing such regulations.*

*The influence of different parameters on contaminant concentrations has been studied in an analytical model. The model includes airflow rates, contaminant generation rates (or measured contaminant concentrations), hood capture efficiencies, and air cleaner efficiencies. Methods have also been designed, tested, and used for measuring hood capture efficiencies and for measuring air cleaner efficiencies for some industrial dusts.*

I would like to thank the National Institute for Occupational Safety and Health for the invitation to speak here on Swedish practices and research on air recirculation. My intention to attend this symposium was not primarily to speak but to listen. The reason is that, outside Sweden, I have found no country other than the United States, except perhaps Western Germany, where work on the problems involved with air recirculation in industry is going on.

The National Board of Occupational Safety and Health is the central Swedish authority for implementing the occupational safety and health legislation. On the regional level there is a Labour Inspectorate in several districts, with supervisory and advisory duties. One department of the National Board is the Department of Occupational Health, which has approximately the same functions as NIOSH. A subdivision of this department is the Ventilation Section. One of our main interests, currently, is the problems associated with general regulations for recirculation of industrial exhaust air.

The existing regulations that apply to air recirculation in Sweden are found in two official documents. One is the Swedish Building Code from 1975 (ref. 1), which applies mainly to new office, school, hospital buildings, etc.; the

---

\*Head of Ventilation Section, Department of Occupational Health, National Board of Occupational Safety and Health, Stockholm, Sweden.

parts that are valid for industrial buildings state that recirculation is allowed if the following requirements are fulfilled.

1. It must be possible to shut off the recirculation systems.
2. Minimum outdoor airflow (supply air) rates must be supplied.
3. The highest design contaminant concentration for all inlet air should be less than 5 percent of actual threshold limit values (TLVs).

Moreover, there is a paragraph in the Swedish Building Code stating that an air conditioning system should include a heat recovery system, if the total enthalpy difference between outlet air and outdoor air is more than 50 MWh per year (170 M Btu's per year). Assuming an 8-month heating period, and mean outlet and outdoor air temperatures of 25° C and 3° C, respectively, which are normal values in Sweden, the building code calls for a heat recovery system if the airflow is more than approximately 5,400 m<sup>3</sup>/h (1.5 m<sup>3</sup>/s or 3,200 ft<sup>3</sup>/min). This provision in the code leads, in most cases, to recirculation being profitable, since one must otherwise install heat exchangers.

The other document is a regulation from the National Board of Occupational Safety and Health from 1972 (ref. 2). In this document there is a paragraph stating that recirculation is not allowed if silica, asbestos, or lead dusts are present. If there are other hazardous or annoying contaminants in the air, it is the individual labour inspector who decides if recirculation is allowed.

Naturally the TLVs (ref. 3) always apply. There are also some separate regulations for specific branches, e.g., industrial vacuum cleaners for asbestos dust must have a minimum filtering efficiency.

In practice these regulations have led to central air recirculation, i.e., recirculation with outdoor air dilution generally being allowed for office buildings, business buildings, etc., and for industrial buildings without hazardous or irritating contaminants. For other industrial buildings, recirculation may be allowed, depending on how the individual labour inspector interprets the regulations, his knowledge of the properties of the contaminants and of air conditioning systems, etc. The interpretation and knowledge naturally vary among different districts and individuals. The same confusing conditions also exist when local air recirculation (i.e., recirculation without outdoor air dilution) is wanted. In the regulations there exists no clear definition of air recirculation, which has had the result that in some labour inspectorate districts, local recirculation is defined as not being recirculation!

The current stand of the National Board (Supervision Department) is not clear, but it seems that the following requirements are normally imposed on central air recirculation systems.

1. No recirculation is allowed if a process contaminant is a carcinogen (suspected or identified) or has a "Skin" notation or a ceiling value.
2. The contaminant concentration in any air inlet diffuser must be lower than 5 percent of the actual TLV.

3. At least 33 percent of the airflow to a workroom must be outdoor air.
4. It must be possible to shut off air recirculation systems.

Sometimes point 2. is extended and also involves a requirement of continuous monitoring.

In order to provide the basis for new, uniform regulations from the National Board of Occupational Safety and Health, we started looking into the problem some years ago. To obtain an understanding of different parameters' influences on contaminant concentrations, we have made an analytical model (refs. 4 and 5). And now we regard model making as a necessary tool and also a necessary condition for creating new regulations for air recirculation.

The model includes airflow rates, contaminant generation rates (or measured contaminant concentrations), hood capture efficiencies, and air cleaner efficiencies. For local exhaust recirculation, our model (see fig. 1) is similar to the model Astleford (ref. 6) designed, but we have used it in another way.

The model is found by setting a mass balance for a room with complete mixing, and solving the obtained differential equation. The solution is

$$C = \left[ \frac{\dot{m} \cdot (1 - \alpha \cdot \eta)}{q_{out} \cdot (1 + \kappa \cdot \eta)} + \frac{C_{in}}{(1 + \kappa \cdot \eta)} \right] [1 - e^{- (1 + \kappa \cdot \eta) \cdot \frac{t}{T}}]$$

In this equation and in the figure the following symbols are used:

- C = Contaminant concentration in the room with recirculation,
- C<sub>in</sub> = Contaminant concentration in supply air (not recirculated),
- C<sub>out</sub> = Contaminant concentration in exhaust air (not recirculated), identical with C,
- q<sub>in</sub> = Supply airflow (not recirculated),
- q<sub>out</sub> = Exhaust airflow (not recirculated),
- q<sub>rec</sub> = Recirculated airflow,
- V = Volume of the room,
- T = Time constant for the room, identical with V/q<sub>out</sub>,
- η = Air cleaner efficiency,
- $\dot{m}$  = Contaminant generation rate,
- α = Hood capture efficiency,
- κ = Air recirculation degree, that is  $\kappa = q_{rec}/q_{out}$ .

Assuming steady state, which is allowable when comparing systems, the time term disappears. Moreover, for many systems the concentration in the supply airflow is negligible and the second term in the first parentheses also disappears.

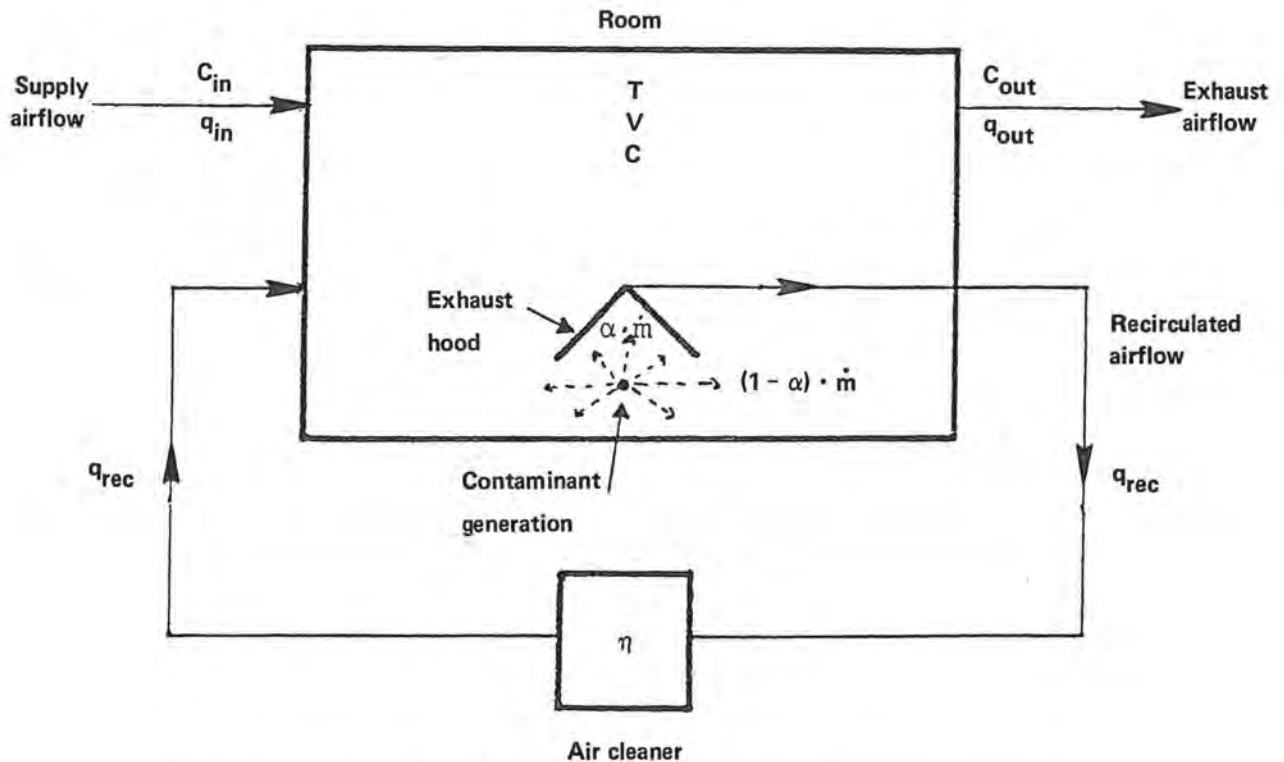

Figure 1. Model for local exhaust recirculation system.

We can then define a concentration,  $C_0$ , by dividing contaminant generation rate,  $\dot{m}$ , with the outlet airflow,  $q_{out}$ . This concentration,  $C_0$ , it appears, is the same concentration that will be found in the room if we do not have any recirculation. We have thus simplified the first equation to the following form:

$$C/C_0 = \frac{1 - \alpha \cdot \eta}{1 + \kappa \cdot \eta} \quad (1)$$

With this equation it is possible to calculate the concentration reduction in a workroom when a recirculation system is introduced, if we know hood capture efficiency, air cleaner efficiency, and the airflows (i.e., relation between outlet airflow and recirculated airflow). It is also possible to calculate contaminant concentration in the recirculated air and the influence of changes in different parameters.

I will here demonstrate one example of the kind of considerations the model makes possible. Suppose that you install a recirculation system for which the hood capture efficiency is 90 percent and the recirculated airflow is 10 percent of the outlet airflow. What filter efficiency should you choose in this case?

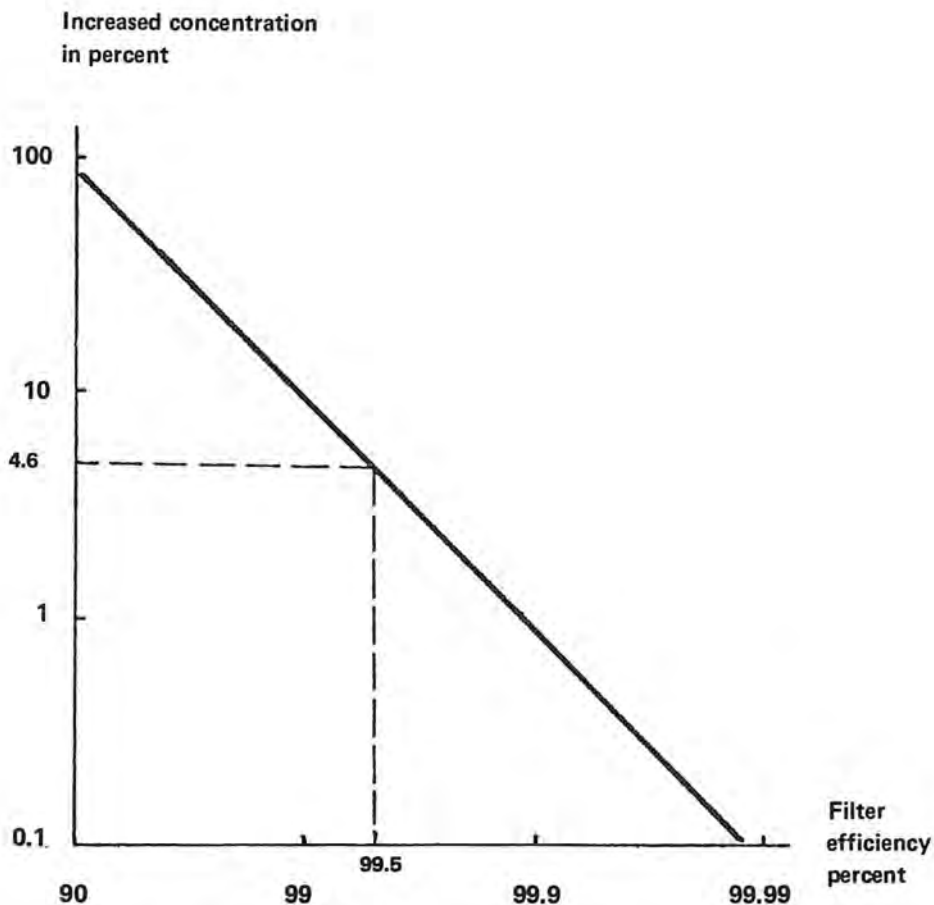

Figure 2. Increase of concentration (in percent) depending on filter efficiency, compared with concentration with 100 percent filter efficiency.

To answer the question we use equation (1) above and compare with a filter efficiency of 100 percent. The relation between concentration difference and filter efficiency is illustrated in figure 2.

From this figure we can see that a filter efficiency of 90 percent will give a concentration approximately 100 percent higher than if the filter efficiency is 100 percent (i.e., no contaminant penetrates or all air is directed outwards). If we take a filter with 99.5 percent efficiency we will get a concentration that is less than 5 percent higher than if no contaminant penetrates the filter. A concentration difference of 5 percent in an industry is neither measurable nor observable. And thus we can see that it would be meaningless in this case to use a filter with a higher efficiency than 99.5 percent.

Naturally, we can use the model to calculate wanted recirculated airflow or outlet airflow or hood capture efficiency if the other parameters are known.

The model also shows that the mentioned practice in Sweden only to demand a contaminant concentration less than 5 percent of the TLV makes it advantageous to have a poor hood capture efficiency. This is one reason for me to think that this practice should be abandoned. The other reason is the great difficulties that will arise if such low concentrations are to be measured continuously.

Of the parameters in the model, the airflow rates and contaminant concentrations are measurable with known methods. Filter efficiencies are normally measured for some standard aerosols, which do not ordinarily exist at workplaces. Since the filter efficiency depends on a number of variables, it is not possible today to predict filter efficiencies for industrial dusts from these standard tests. We have therefore studied and developed measurement methods for determining efficiencies of filters for oil mist, welding fumes, and respirable silica dust. We intend to look at the possibilities of relating standard test efficiencies to efficiencies for industrial dusts.

The hood capture efficiency is a parameter that is not normally known, since most hoods are designed with the help of capture velocities (ref. 7). However, we have designed a method for determination of hood capture efficiency of low volume/high velocity exhaust systems and we have measured capture efficiencies of systems for portable grinding and polishing machines and for a hammer drill (ref. 8). We have also measured capture efficiencies of a number of exhaust hoods for welding fumes.

Thus, we have for some common industrial operations obtained preliminary numerical values of all parameters in the recirculation model.

However, differences always exist between a theoretical model and reality, and one of the problems when using recirculation in new buildings, sometimes also in old ones, is to predict the contaminant transport in a room. We are trying to use tracer-gas to measure the efficiency of the dilution ventilation in a room, but it is an approach that involves great difficulties. I know that you here in the United States use an empirical factor, K, when designing air conditioning systems (ref. 7). At the Royal Institute of Technology, Sweden, two research projects are being carried out whose main purpose is to investigate the relationship between different air currents and the relative movements of different industrial aerosols. In these projects, some of the results imply that air contaminants may concentrate in the center of macroscopic vortices in rooms.

Another problem is the possibility of a failure of an air cleaner. The only certain way of controlling air cleaner efficiencies is to use continuous contaminant measurements. There are, however, a lot of problems connected with continuous measurement of the low concentrations after air cleaners, but in the last few years some new instruments have been developed that may be usable. In Sweden there is one project going on aimed at constructing a relatively cheap aerosol monitor intended for use in recirculation systems.

I believe that air recirculation will be allowed in Sweden to a greater extent in the future. I would like to see the following distinctions and general requirements made concerning central and local systems.

For central air recirculation systems:

1. These systems must be designed by air conditioning engineers in cooperation with professionals of industrial hygiene.
2. No limit should exist for the proportion of recirculated air in relation to supply air. There should only exist a minimum supply of outdoor airflow depending on the number of working persons.
3. The contaminant concentration in the recirculated air must be lower than, for example, 50 percent of the actual TLV.
4. The contaminant concentration must be monitored continuously, either in the recirculated air or in the air at the workplaces.
5. The systems must have either a bypass to outdoor air or a shutoff.
6. A list must specify for which contaminants air recirculation is allowed (or not allowed).

For local air recirculation systems:

1. A representative example of each system must have been tested and approved by the National Board of Occupational Safety and Health. The test should include measurements of filter efficiency and hood capture efficiency.
2. There must be instructions for use and maintenance on every system.
3. The total recirculated airflow must be limited compared with the nonrecirculated airflow.
4. As for central systems, a list must specify for which contaminants air recirculation is allowed (or not allowed).

Our work on air recirculation systems can thus be summarized as follows. The engineers who design air conditioning systems can reduce heat consumption and minimize costs either by using heat exchangers or by recirculating air. The existing regulations applying to the use of heat exchangers are sufficient for making it possible to calculate, in advance, the investment costs, yearly costs, and returns. These calculations are not possible for air recirculation, because the regulations are partly nonexistent and partly nonuniform and confusing. We intend to write as soon as possible a uniform regulation proposal for air recirculating systems, which will make it possible to compare economically heat exchanger systems with air recirculation systems already on the drawing-board. With this proposal we hope that the industry, the trade unions, the labour inspectors and the regulation department people will be content, since all of them for years have been wanting clear, uniform regulations for air recirculation systems.

#### REFERENCES

1. Swedish Building Code 1975 (SBN 1975), Chapters on Ventilation and Energy Conservation, Swedish National Board of Physical Planning and Building 1976. (In Swedish, English summary.)
2. Swedish National Board of Occupational Safety and Health, "Regulations for workrooms (Lokalanvisningar)," Stockholm, 1972. (In Swedish.)

3. Swedish National Board of Occupational Safety and Health, "Regulations for concentrations of contaminants on workplaces (Hygieniska gränsvärden)," Stockholm, 1974. (In Swedish.)
4. L. Olander, "Air recirculation (Återluftfö<sup>o</sup>ring)," VVS (Swedish Heating and Ventilation Journal), Vol. 8, 1974, pp. 53-56. (In Swedish.)
5. L. Olander, "An analytical model for recirculation of air from exhaust hoods (Dimensionering av återluftfö<sup>o</sup>ringssystem med hänsyn till föroreningsalstring)," Work & Health (Arbete & Hälsa), Vol. 1, National Board of Occupational Safety and Health (Arbetarskyddsverket), Stockholm, 1977. (In Swedish, English summary.)
6. W. J. Astleford, "Development of Criteria for the Recirculation of Exhaust Air," Southwest Research Institute, Final Report, Contract CDC-99-74-96, July 1975.
7. American Conference of Governmental Industrial Hygienists, Industrial Ventilation - A Manual of Recommended Practice, 14th edition, 1976.
8. L. Olander and S. Krantz, "A method for testing the hood capture efficiency for local exhaust hoods (En metod att bedöma punktutslugningssystem infångningsförmåga)," Work & Health (Arbete & Hälsa), Vol. 2, National Board of Occupational Safety and Health (Arbetarskyddsverket), Stockholm, 1976. (In Swedish, English summary.)

#### DISCUSSION

MR. GEORGE HAMA (Consultant, Huntington Woods, Michigan): I don't feel that that model is practical to work with in industry because it uses hood capture efficiencies. In this country, as far as I know, in the ventilation field there are actually no data on what capture efficiencies are. I'm not saying you can't get laboratory study capture efficiencies, although it's quite an involved study to get them; however, when you do get them, if you apply them to actual industrial operations, you may have to modify them to fit the hoods located in machines and special working conditions. There will be likely variance in cross-draft velocities that will change the efficiencies. As far as I can see I don't think we can approach this thing practically using hood efficiencies. For example, you might get a hood efficiency in the laboratory for welding, but I doubt that it would meet all the variable conditions you encounter, such as distance from hood or from source of contaminant and cross-drafts.

PROFESSOR OLANDER: I'm quite sure that most people in Sweden also agree with you. We don't have the resources you have here in the United States, and as I said my intention was to learn. When I wrote this 3 months ago we were approximately at the same level as you were 2 years ago on the work on recirculation. On your remark I want to state that we have used the model to get an understanding of the sizes of different parameters' influence. And when comparing an exhaust system without recirculation with the same system with recirculation (equation 1), we naturally assume that

the hood capture efficiency is the same, that is, it has the same variations or the same constant value. I agree with you regarding the problems if the hood capture efficiency should be used for determining the concentrations.

CHAIRMAN HUGHES: Your equation also uses the mass generation. What type of information do you have on mass generation process?

PROFESSOR OLANDER: We have made measurements for different welding operations, for different grinding operations, and for different drilling operations. I can't tell you if and where they are going to be publicized, but we have the measurements made, and everyone who tried to make that kind of measurements knew there were great problems in making them. We have not determined the connection between hood capture efficiency and different mass generations. Instead we have measured the hood capture efficiencies for the highest possible mass generation rate for each operation. For example, the hoods for welding fume have been measured for continuous welding with different sizes of welding rods. In reality, there is no welder who welds continuously.

CHAIRMAN HUGHES: In the regulations that you have, or would propose, you would probably tend more to look at the type of model that we have developed?

PROFESSOR OLANDER: We do not intend to include a model in the regulations.



## RECAPITULATION

Peter W. Kalika\*

When John Yocom first asked me to substitute for him at this symposium, I had the impression that he had a paper to present, and I thought he would hand me his manuscript, I would read it, field a few questions, and that would be that. But, the day before I left, he handed me the program, and there it was . . . do the Recapitulation.

Well, this is certainly a new experience; I don't know about all of you, but at meetings like this, I practice selective listening. Different speakers move me to varying levels of attentiveness depending on their presentation style or their topic. My notetaking is usually spotty, especially if I know proceedings are to be published. But when you have to wrap it up, as is my assignment here, things take on a different perspective. You listen to everything, you take lots of notes. Some of you sitting on the right side of the room yesterday may have wondered, what's with the guy with all the furious scribbling in the dark? When I got to the hotel room last night, clutching my notes, I had this sinking thought about the guy who wakes up in the middle of the night with this absolutely fantastic idea for energy conservation. He writes it down and goes happily back to sleep. You know what happens when he wakes up--he can't read it--it's gibberish. To my pleasant surprise, I was able to read my notes, and I will now share my thoughts with you.

Walter Haag and Robert Hughes opened the symposium with their comments on the NIOSH plans with respect to developing information on the feasibility of exhaust air recirculation. Mr. Haag emphasized NIOSH's desire for finding actual installations for evaluation of control, monitoring, and protective equipment technology in various industries, and for encouraging a sharing of available information on the part of industry. With respect to this symposium, the objective was to review the work of the Arthur D. Little Company to validate the guidelines they developed in actual field and pilot installations, to take advantage of the research that was done, and to put the guidelines to work.

Bob Hughes gave us a thought-provoking analogy by reducing the total span of life on Earth to a "geological year." It is certainly sobering to visualize that our fossil fuel consumption in total is represented by just a few seconds before midnight on December 31, and our remaining supplies represent just a few seconds after midnight. Bob further set forth the following ground rules for our deliberation:

---

\*Engineering Manager, TRC-The Research Corporation of New England, Wethersfield, Connecticut.

1. We are not here to encourage or discourage recirculation, but to encourage an organized approach to its evaluation.
2. It is not NIOSH's intention to use the guidelines developed by A. D. Little to evolve regulatory criteria.
3. It is recognized that recirculation is not the only energy conservation measure applicable to exhaust air from industrial operations.

Scott Stricoff and John Hagopian of A. D. Little presented a summary of their work. I had a brief look at their draft report early yesterday morning, and it certainly is a formidable document. In my mind, certain key points made by Scott and John bear repeating. First of all, the emphasis of the study is worker safety. They sought general system specifications and design procedures, not detailed design information. That is, they intend to present to the user and designer those considerations that must be understood before undertaking a recirculation project: safety is the only criterion, and the guidelines are intended to help achieve safety when recirculation is practiced. Another important fact recognized by the study is that systems will fail and that the consequences of such failures must be considered and corrective action must be planned. Also, the study points out that all contaminants must be identified and levels measured, and encourages the involvement of an occupational health professional in the development of the system. Monitoring and postinstallation performance testing are also emphasized, and it is recognized that the inability to specify a satisfactory monitoring concept could be the only factor needed to cause recirculation to be abandoned. The use of modeling as an analytical design tool is presented, with an emphasis on subsequent validation and model modification. My observation is that modeling is a valid and cost-effective procedure in many fields and should be no less so in attempting to apply recirculation. And finally, the emphasis that each case be considered on its individual merits is vital to the tone of the report, as is its recognition of the realities of maintenance requirements, its planning, implementation, and documentation.

Bill Dyson of Burlington Industries gave us a critique of the A. D. Little report. Bill was complimentary, and noted as particular strengths of the report its emphasis on worker safety and the involvement of occupational health professionals. The extension of modeling to include failure and maintenance analysis capability was also praised by Bill. On the negative side, a lack of detail in equipment selection criteria was cited, as was a weakness in the validation strategy in not making sufficient reference to recent literature on exposure sampling strategies. Also, the complexity of the presentation on modeling information was seen as potentially diminishing the audience of the report. Bill made the interesting comment that a copy of the report would be better located in the office of the industrial hygienist than in the office of the ventilation design engineer. This comment was challenged by several participants during the question and answer session. John Talty of NIOSH stated that nonuse of the report by engineers would be unfortunate, and Mr. Eshelman of GM felt that the design information was too deeply buried. My personal comment is that a restructuring of the report to respond to this concern certainly appears to be in order. Another important factor raised during the discussion, which should receive attention from the authors and NIOSH, is whether the need for monitoring is unfairly hung on only the recirculation concept, that the same stigma should be put at the same time on the

equipment already operational. Hanging it all on recirculation appears to be discouraging application of the concept. Mr. Hughes agreed that clarification of this point was appropriate.

Mr. James Lim then discussed the view of recirculation by the California State Department of Health. In general, the California regulations are "permissive" toward recirculation, but this is due to California's warm climate, which requires little tempering of makeup air. The expense of recirculation is seldom justifiable. However, Mr. Lim believes that the practice will eventually become more attractive as energy costs continue to rise and air pollution emission limitations become more stringent.

The panel discussion then raised a number of interesting points: Mr. Barrett reminded us of the limitations of modeling, since there are many ways that ventilation systems are put together in the real world; and of the imprecision of TLVs. These, and the modeling equations, must be used with judgment. He also said that specific application details will dictate choices such as duct vs. air monitoring, and that personal sampling may be a legal obligation in some cases.

Tom Bloom of NIOSH brought up the question of the effect of outdoor pollutant concentrations, for example, carbon monoxide on the operation of a recirculation system. John Hagopian pointed out that the model equations include the contaminant concentration in the makeup air, and that it would be possible to end up with cleaner workroom air with recirculation if outside air is heavily contaminated. My own experience on indoor-outdoor pollutant relationship studies also points this out, especially in the office building HVAC systems where high degrees of circulation are practiced, especially during hot weather. The location of makeup air intakes with respect to external contaminant sources is also an important factor here. Two other questions were raised that should be noted. First, the question of insurance considerations as to product liability in monitoring system operation when air is recirculated; that is, could the monitor indicate "all's well" while employees complain of illness? The second question relates to the potential of the recirculation system for altering the nature of the contaminant being dealt with, as, for example, with electrostatic precipitator (ESP) ozone generation or with fine particulate being built up, because of control system fractional efficiency characteristics.

Richard Stephens of Energy Resources Company then provided a picture of our national energy options which shows that energy conservation is our major thrust for the next 10 years or so. Mr. Stephens' figures indicated that the commercial sector appears to harbor more potential for application of recirculation than the industrial sector, apparently because the contaminant problem is less severe. He also pointed out that energy management technology provides many alternatives to the energy manager, of which recirculation is only one. Energy management is seen as a full-time job today.

John Talty of NIOSH reviewed the state of technology in air cleaning equipment. Potential controls include electrostatic precipitators, fabric filters, absorbers, adsorbers, and various wet collectors, particularly high-energy systems. The potential for ozone generation of ESPs was briefly discussed from the floor. It was pointed out that such contributions have never been known to even approach the ozone TLV.

Steven Chansky of GCA Corporation concluded yesterday's session with his presentation on contaminant monitoring. Mr. Chansky presented a number of pertinent instrument parameters and then reviewed presently available continuous particulate matter monitoring instruments against these parameters. His review pointed out three instruments with potential application: the Leitz nephelometer and two GCA Beta Attenuation Systems, one with impaction collection, the second with filtration collection. Both of the latter involve extraction of samples via a probe, with obvious potential for errors due to probe losses. This is a personal observation: I was disappointed that under the broad heading of contaminant monitoring, we did not have a discussion of continuous monitoring of gaseous contaminants, which seem to represent the greater portion of potentially recirculatable contaminants. I would also like to add my voice to those I have heard in several instances saying that monitoring does not necessarily have to be specific for the contaminant in question. Inferential monitoring concepts should certainly receive consideration. We have progressed beyond the canary in the mine, but let's avoid promoting complexity for its own sake.

This morning we heard Mr. Bullock describe his plans for validation of the recirculation design criteria at three industrial sites, and we heard that the use of the model is contemplated, particularly with respect to the two contribution parameters. It is unfortunate that the work is not further along at this time so that more specific results could have been reported on the utility of the guidelines. Mr. Bullock offered as a conclusion that the guidelines may be limited in their application to fairly large users, i.e., large firms and/or their consultants. As the material is now structured, I would tend to agree. I am sure that the authors and NIOSH will give this concern strong consideration before the report is issued, because the little guy needs help too.

Bob Potokar of GM gave us a review of the activities and plans of the American Foundrymen Society's task force on recirculation. Five foundries have agreed to participate in a step-by-step demonstration effort of recirculation in foundry cleaning rooms. Here again, the work is just getting underway, so Bob had little by way of specifics to report to us. One point was made that has not been stressed enough in my mind, and that is that successful recirculation provides an opportunity to provide enough air to improve the capture effectiveness of hoods which, because of efforts to minimize exhaust, may not be achieving optimum capture velocities. That is to say, recirculation is a means not only to save energy, but can improve in-plant air quality.

George Hama provided us with some of industry's viewpoints, and those of a private consultant, on the topic of recirculation. He pointed out that industry-specific criteria would be most helpful. George pointed out that allowing in-plant concentrations to increase closer to the TLV could create labor problems. This is analogous to the nondegradation dilemma faced in the achievement of outdoor ambient air quality standards. From a consultant's point of view, George pointed out that a conservative approach would be taken.

Professor Olander's comments regarding Sweden's approach to recirculation were very interesting. Sweden has regulations covering recirculation, yet they are not uniformly interpreted or applied so that valid cost comparisons cannot be made with other heat recovery alternatives. Professor Olander reviewed crite-

ria to be applied to application of recirculation systems. I believe these parallel those proposed in the A. D. Little study in most cases. It is interesting to note that the model parameters have been evaluated in process-specific cases, that is, validation is underway. It would be valuable if some of this information could be made available to researchers in the United States.

To conclude this recapitulation I would like to speculate on what sort of forum should be provided for future exchange of information. I would recommend that NIOSH consider another symposium in a year or two that would concentrate entirely on real-life experiences in attempting to validate the guidelines that have been developed; not just those studies sponsored by NIOSH, but hopefully some that industry has undertaken on its own. I realize it is often difficult to pry this kind of information loose, but I think it will be worth the effort to seek it out for presentation and discussion.



## CLOSING REMARKS

Robert T. Hughes\*

In closing, I would like to make a request. It was discussed several times, and Bob Potokar brought it up again in his presentation, that there is a need for cooperation among industry, government, and technical societies. We have been in contact with the Foundrymen's Society with respect to our validation efforts, but I feel that there probably are a lot of people in industry who have been using recirculation systems. I would like to request that they share that information with us. We intend to pull together all of our validation efforts and use them to modify, as required, the criteria in the A. D. Little report, and to develop a final set of criteria or guidelines.

We have listened to comments of the problems that people seem to have with the approach, the titles, and organization of the ADL report. We intend to consider these both in the final report and in directing our future efforts.

---

\*Chief, Chemical Agents Control Section, CTRB, DPSE, NIOSH, Cincinnati, Ohio.



Appendix. List of Speakers and Attendees

Speakers

Mr. James C. Barrett  
Bureau of Environmental &  
Occupational Health  
DEPARTMENT OF PUBLIC HEALTH  
3500 N. Logan Street  
Lansing, Michigan 48914

Mr. Lawrence F. Bullock  
Environmental Sciences Division  
ENVIREX, INC.  
5103 W. Beloit Road  
Milwaukee, Wisconsin 53214

Mr. Steven H. Chansky  
Instrumentation Marketing  
GCA CORPORATION  
Bedford, Massachusetts 01730

Mr. William Dyson  
Medical Department  
BURLINGTON INDUSTRIES  
Post Office Box 21207  
Greensboro, North Carolina 27420

Mr. Walter A. Haag  
Division of Physical Sciences &  
Engineering  
NIOSH  
4676 Columbia Parkway  
Cincinnati, Ohio 45226

Mr. John Hagopian  
ARTHUR D. LITTLE, INC.  
20 Acorn Park  
Cambridge, Massachusetts 02140

Mr. George Hama  
25120 East Roy Court  
Huntington Woods, Michigan 48070

Mr. Robert T. Hughes  
Chemical Agents Control Section  
DIVISION OF PHYSICAL SCIENCES  
& ENGINEERING - NIOSH  
4676 Columbia Parkway  
Cincinnati, Ohio 45226

Mr. Peter W. Kalika  
THE RESEARCH CORPORATION OF  
NEW ENGLAND  
125 Silas Deane Highway  
Wethersfield, Connecticut 06109

Mr. James Lim  
Supervising Industrial Hygiene  
Engineer  
STATE DEPARTMENT OF HEALTH  
Berkeley, California 94704

Mr. Lars Olander  
NATIONAL BOARD OF OCCUPATIONAL  
SAFETY & HEALTH  
Department of Occupational Safety  
& Health  
Ventilation Section  
FACK  
S-10026  
Stockholm, Sweden

Mr. Robert W. Potokar  
Manufacturing Staff  
GM CORPORATION  
GM Technical Center  
Warren, Michigan 48090

Mr. Richard H. Stephens  
Energy Systems Division  
Energy Resources Company  
Cambridge, Massachusetts 02129

Mr. R. Scott Stricoff  
ARTHUR D. LITTLE COMPANY  
20 Acorn Park  
Cambridge, Massachusetts 01982

Mr. John T. Talty  
Division of Physical Sciences  
& Engineering  
NIOSH  
4676 Columbia Parkway  
Cincinnati, Ohio 45226

## Attendees

Mr. Fred G. Allenbaugh  
Environmental Control  
FERRO CORPORATION  
1150 East 56th Street  
Cleveland, Ohio 44105

Mr. Alfred A. Amendola  
Control Technology Research Branch  
DIVISION OF PHYSICAL SCIENCES AND  
ENGINEERING - NIOSH  
4676 Columbia Parkway  
Cincinnati, Ohio 45226

Mr. John T. Ashe  
Air Filter Products Department  
AMERICAN AIR FILTER CO., INC.  
215 Central Avenue  
Louisville, Kentucky 40201

Mr. Franklin A. Ayer  
Center for Technology Applications  
RESEARCH TRIANGLE INSTITUTE  
P. O. Box 12194  
Research Triangle Park, N. C. 27609

Mr. Richard Bahn  
MN 12-4240  
HONEYWELL INCORPORATED  
Honeywell Plaza  
Minneapolis, Minnesota 55408

Mr. Bruce Black  
PACKARD ELECTRIC  
Division of General Motors  
Corporation  
Post Office Box 431  
Warren, Ohio 44486

Mr. Tom Bloom  
NIOSH  
4676 Columbia Parkway  
Cincinnati, Ohio 45226

Mr. Donald A Brown  
OCCUPATIONAL HEALTH BUREAU  
Ministry of Labour  
15 Overlea Boulevard  
Toronto, Ontario, Canada

Mr. David J. Burton  
D.B. ASSOCIATES, INCORPORATED  
1864 South State Street  
Salt Lake City, Utah 84115

Mr. John Callis  
KENTUCKY DEPARTMENT OF LABOR  
151 Elkhorn Court  
Frankfort, Kentucky 40601

Mr. William Cheney  
UNITED AIR SPECIALISTS  
6665 Creek Road  
Cincinnati, Ohio 45215

Mr. Dennis Collins  
OSHA  
Room 4028 Federal Office Building  
550 Main Street  
Cincinnati, Ohio 45202

Mr. John Connors  
PACKARD ELECTRIC GMC  
Warren, Ohio

Mr. Richard J. Coomes  
THE PROCTOR & GAMBLE COMPANY  
Ivorydale Technical Center  
Cincinnati, Ohio 45217

Mr. Nelson W. Couch  
131 Vernon Avenue  
COLUMBUS AFB  
Columbus, Mississippi 39701

Mr. Clinton Cox  
NIOSH  
4676 Columbia Parkway  
Cincinnati, Ohio 45226

Mr. W. F. Crowder  
Industrial Hygiene  
D/55-11, Zone 277  
LOCKHEED GEORGIA  
Marietta, Georgia 30063

Mr. Guy F. Cusumano  
AXE-DUST CORPORATION  
Post Office Box 93  
Tennent, New Jersey 07763

Attendees (con.)

Mr. Kenneth Dalley  
MC 3803  
STANDARD OIL COMPANY (INDIANA)  
200 East Randolph Drive  
Chicago, Illinois 60601

Mr. Ronald J. Delaet  
DELCO MORAIN DIVISION GMC  
1420 Wisconsin Boulevard  
Dayton, Ohio 45401

Mr. Gerald E. Devitt  
OWENS CORNING FIBERGLAS  
Fiberglas Tower - T-11  
Toledo, Ohio 43659

Mr. Louis Dickie  
DCE VOKES INCORPORATED  
10101 Linn Station Road  
Suite 900  
Jeffersontown, Kentucky 40223

Mr. Laurence J. Doemeny  
DIVISION OF PHYSICAL SCIENCES &  
ENGINEERING  
4676 Columbia Parkway  
Cincinnati, Ohio 45226

Mr. Raul Escobar  
MEXICAN INSTITUTE FOR SOCIAL SECURITY  
Luz Savionon No. 1863  
Mexico 12 D.F. Mexico

Mr. Phelps S. Eshelman  
Industrial Hygiene Department  
RAB3-229  
GENERAL MOTORS TECHNICAL CENTER  
Warren, Michigan 48090

Mr. John W. Feuk  
Industrial Hygiene Services  
MINNESOTA MINING & MANUFACTURING CO.  
Building 220-2E  
3M Center  
St. Paul, Minnesota 55101

Mr. Jerry Flesch  
NIOSH  
4676 Columbia Parkway  
Cincinnati, Ohio 45226

Mr. Edward Foley  
NIOSH  
4676 Columbia Parkway  
Cincinnati, Ohio 45226

Mr. Robert F. Gempel  
HARVARD UNIVERSITY - SCHOOL OF  
PUBLIC HEALTH  
665 Huntington Avenue  
Boston, Massachusetts 02115

Mr. James Gideon  
NIOSH  
4676 Columbia Parkway  
Cincinnati, Ohio 45226

Mr. Matthey Gillen  
STUDENT KETTERING LABS  
Cincinnati, Ohio

Mr. John S. Gorski  
KEMPER/NATLSCO  
Long Grove, Illinois 60049

Mr. Eugene E. Grassel  
DONALDSON COMPANY, INC.  
1400 W. 94th Street  
Post Office Box 1299  
Minneapolis, Minnesota 55440

Mr. Jeff Green  
KOHLER COMPANY  
Kohler, Wisconsin 53044

Mr. Jean Guay  
GOVERNMENT OF QUEBEC  
Environmental Protection Service  
2360 Sainte Soy Road  
Quebec, Canada

Mr. Bill Hall  
QUAKER OATS COMPANY  
Barrington, Illinois 60010

Mr. John W. Hammersmith  
Mail Station F-3  
AMOCO RESEARCH CENTER  
Post Office Box 400  
Naperville, Illinois 60540

Attendees (con.)

Mr. William A. Heitbrink  
NIOSH  
Cincinnati, Ohio

Mr. Geoff Hewitt  
HNU SYSTEMS, INC.  
30 Ossippic  
Newton, Massachusetts 02164

Mr. John L. S. Hickey  
RESEARCH TRIANGLE INSTITUTE  
P. O. Box 12194  
Research Triangle Park, N.C. 27709

Mr. Douglas W. Hitson  
Environmental Engineering Division  
ALUMINUM COMPANY OF AMERICA  
1501 Alcoa Building  
Pittsburgh, Pennsylvania 15219

Mr. Ron Holzhauer  
PLANT ENGINEERING MAGAZINE  
1301 S. Grove Avenue  
Barrington, Illinois 60010

Mr. William B. Huelson  
AMERICAN FOUNDRYMEN'S SOCIETY  
Golf & Wolf Roads  
Des Plaines, Illinois 60016

Mr. J. S. Hughes  
KENTUCKY UTILITIES CO.  
120 South Limestone  
Lexington, Kentucky 40507

Mr. Lawrence L. Johnson  
CHEVROLET CENTRAL OFFICE  
Facilities & Environmental  
Engineering  
80007 Van Dyke  
Warren, Michigan 48090

Mr. Wilbert Jordan  
ETHYL CORPORATION  
451 Florida Street  
Baton Rouge, Louisiana 70801

Mr. Jerry Kelly,  
GENERAL ELECTRIC  
Nela Park  
Cleveland, Ohio 44112

Mr. R. L. Kilgore  
LOCKHEED-GEORGIA COMPANY  
86 South Cobb Drive  
Marietta, Georgia 30063

Mr. Lee Kochan  
GLOBE UNION CORPORATION  
Milwaukee, Wisconsin 53200

Mr. Joseph F. Kukla  
Sentry Insurance  
1800 N. Point Drive  
Stevens Point, Wisconsin 54881

Mr. Alexander A. Langa  
ELECTRONIC ASSOCIATES, INC.  
185 Monmouth Parkway  
West Long Branch, New Jersey 07764

Mr. Ralph R. Langner  
DOW CHEMICAL U.S.A.  
1803 Building  
Midland, Michigan 48640

Mr. K. W. Lee  
BATTELLE COLUMBUS LABORATORIES  
Columbus, Ohio 43201

Mr. Robert D. Mahon  
Division of Physical Science and  
Engineering, NIOSH  
4676 Columbia Parkway  
Cincinnati, Ohio 45226

Mr. Ron McCann  
USDL-OSHA  
Rm. 4028 FOB 550 Main Street  
Cincinnati, Ohio 45202

Mr. William McKinnery  
NIOSH  
4676 Columbia Parkway  
Cincinnati, Ohio 45226

Mr. Joseph B. Medved, P.E.  
Senior Environmental Engineer  
Central Foundry Divisional Office  
GMC  
77 W. Center Street  
Saginaw, Michigan 48605

Attendees (con.)

Mr. Bruce Menkel  
2242 West Shantz  
Dayton, Ohio 45409

Mr. Stephen Messinger  
OSHA  
550 Main Street  
Room 4028, Federal Office Bldg.  
Cincinnati, Ohio 45215

Mr. Carl Moline  
NIOSH  
4676 Columbia Parkway  
Cincinnati, Ohio 45226

Mr. Gary Mosher  
AMERICAN FOUNDRYMEN'S SOCIETY  
Golf and Wolf Roads  
Des Plaines, Illinois 60016

Mr. Clifford L. Mosley  
NIOSH  
4676 Columbia Parkway  
Cincinnati, Ohio 45226

Mr. Dennis O'Brien  
NIOSH  
4676 Columbia Parkway  
Cincinnati, Ohio 45226

Mr. Loran Odell  
MN 12-4240  
HONEYWELL INCORPORATED  
Honeywell Plaza  
Minneapolis, Minnesota 55408

Mr. H. S. Pei  
BOLT BERANEK AND NEWMAN, INC.  
50 Moulton Street  
Cambridge, Massachusetts 02138

Mr. Charles D. Pollis  
HONEYWELL, INCORPORATED  
19 Knollcrest Drive  
Cincinnati, Ohio 45237

Mr. Thomas I. Prosek  
OWENS-CORNING FIBERGLAS  
Fiberglas Tower, FF/7  
Toledo, Ohio 43659

Mr. Paul Pryor  
NIOSH  
4676 Columbia Parkway  
Cincinnati, Ohio 45246

Mr. P. F. Pullen  
RIO ALGOM LIMITED  
120 Adelaide Street West  
Toronto, Canada M5H 1W5

Mr. Carl Quakenbush  
Health & Safety Systems  
KOHLEH COMPANY  
44 High Street  
Kohler, Wisconsin 53044

Mr. Lionel Reynolds  
USDOL-OSHA, Room 634  
200 N. High Street  
Columbus, Ohio 43215

Mr. Gordon Roush  
THE DOW CHEMICAL CO. U.S.A.  
1803 Building  
Midland, Michigan 48640

Mr. Jerry C. Ruddle  
Center for Technology Applications  
RESEARCH TRIANGLE INSTITUTE  
P. O. Box 12194  
Research Triangle Park, N.C. 27709

Mr. Don R. Scarbrough  
NORDSON CORPORATION  
Jackson Street  
Amherst, Ohio 44001

Ms. Ellen M. Scheide  
3M COMPANY  
3M Center - Building 220-2E  
Saint Paul, Minnesota 55101

Mr. Ken Schoultz  
ENVIRO CONTROL, INCORPORATED  
11300 Rockville Pike  
Rockville, Maryland 20852

Mr. John O. Schubert  
UNITED AIR SPECIALISTS  
6665 Creek Road  
Cincinnati, Ohio 45242

Attendees (con.)

Mr. Gary Sheesley  
THE MCCLEOD COMPANY  
11755 Mosteller Road  
Cincinnati, Ohio 45226

Mr. J. Mall Sims  
KERMATROL  
P. O. Box 907  
Monroeville, Alabama 36460

Mr. David Smith  
NIOSH  
4676 Columbia Parkway  
Cincinnati, Ohio 45226

Mr. John Spriggs  
DONALDSON COMPANY, INC.  
Post Office Box 1299  
Minneapolis, Minnesota 55440

Mr. John K. Stockham  
USDOL - OSHA  
200 N. High Street  
Columbus, Ohio 43215

Mr. Robert Tomkalski  
CLEVELAND TWIST DRILL COMPANY  
1242 E. 49th Street  
Cleveland, Ohio 44114

Mr. Jack C. Trick  
ATA, INC.  
2309 Pearl Street  
Post Office Box 2400  
Anderson, Indiana 46011

Mr. Harold Van Wagenen  
NIOSH  
4676 Columbia Parkway  
Cincinnati, Ohio 45226

Mr. Cliff Watson, P.E.  
TEPCO, INCORPORATED  
2705 Industrial Lane  
Garland, Texas 75041

Mr. Robert J. Weishapl  
Engineering Department  
DU PONT COMPANY  
33W24 Louviers Building  
Newark, Delaware 19898







DEPARTMENT OF  
HEALTH, EDUCATION, AND WELFARE

PUBLIC HEALTH SERVICE

CENTER FOR DISEASE CONTROL

NATIONAL INSTITUTE FOR OCCUPATIONAL SAFETY AND HEALTH

ROBERT A. TAFT LABORATORIES

4676 COLUMBIA PARKWAY, CINCINNATI, OHIO 45226

---

OFFICIAL BUSINESS

PENALTY FOR PRIVATE USE, \$300



POSTAGE AND FEES PAID  
U.S. DEPARTMENT OF H.E.  
HEW 399