**ANALYSIS OF
COAL REFUSE DAM FAILURE**

**MIDDLE FORK BUFFALO CREEK
SAUNDERS, WEST VIRGINIA**

**UNITED STATES
DEPARTMENT OF THE INTERIOR
BUREAU OF MINES
WASHINGTON, D.C.**

USBM CONTRACT NO. S0122004

VOLUME 1 OF 2 - TEXT

FEBRUARY 1973

**W. A. WAHLER
& ASSOCIATES**

**ENGINEERS & CONSULTANTS
DAM AND RESERVOIR ENGINEERING
AND GEOLOGY**

PB 215 142

**ANALYSIS OF
COAL REFUSE DAM FAILURE**

**MIDDLE FORK BUFFALO CREEK
SAUNDERS, WEST VIRGINIA**

**UNITED STATES
DEPARTMENT OF THE INTERIOR
BUREAU OF MINES
WASHINGTON, D.C.**

USBM CONTRACT NO. S0122084

VOLUME 1 OF 2 - TEXT

FEBRUARY 1973

Reproduced by
**NATIONAL TECHNICAL
INFORMATION SERVICE**
U.S. Department of Commerce
Springfield VA 22151

**W. A. WAHLER
& ASSOCIATES**

BIBLIOGRAPHIC DATA SHEET	1. Report No. BuMines OFR 10(1)-73	2.	3. Recipient's Accession No. PB 215 142
	4. Title and Subtitle Analysis of Coal Refuse Dam Failure. Middle Fork Buffalo Creek, Saunders, West Virginia. Volume 1. Text		5. Report Date February 1973
7. Author(s) W. A. Wahler & Associates		6. Performing Organization Code	
9. Performing Organization Name and Address W. A. Wahler & Associates 1023 Corporation Way Palo Alto, CA 94303		8. Performing Organization Rept. No.	10. Project/Task/Work Unit No.
12. Sponsoring Agency Name and Address Office of Deputy Director--Health and Safety Bureau of Mines U.S. Department of the Interior Washington, DC 20240		11. Contract/Grant No. S0122084	
15. Supplementary Notes Volume I of two-part report.		13. Type of Report & Period Covered Contract report	
16. Abstracts On February 26, 1972, a coal refuse dam, owned and operated by the Buffalo Mining Company, failed near Saunders, W. Va. The resulting flooding of the Buffalo Creek Valley had national ramifications. The immediate consequences of the flooding were the deaths of 118 persons and 7 reported missing, the loss of over 500 homes, and extensive flood damage to other property in Buffalo Creek Valley. Several investigations were started immediately after the disaster. They relied primarily on personal observations, and eyewitness reports, although the U.S. Army Corps of Engineers and the U.S. Geological Survey undertook limited field and laboratory testing. These original investigations contributed to an understanding of the Buffalo Creek Flood. This study presents a comprehensive view of the failure with essential data integrated from many sources, and an analysis of the failure based on a thorough program of subsurface exploration and sampling, field and laboratory testing, and engineering analyses.		14. Sponsoring Agency Code	
17. Key Words and Document Analysis. 17a. Descriptors Coal refuse dam Buffalo Creek flood Failure Saunders, W. Va. Buffalo Creek Flood			
17b. Identifiers/Open-Ended Terms			
17c. COSATI Field/Group 13L			
18. Distribution Statement Release unlimited by NTIS.		19. Security Class (This Report) UNCLASSIFIED	21. No. of Pages 268
1		20. Security Class (This Page) UNCLASSIFIED	22. Price \$ 6.75

The views and conclusions contained in this document are those of the authors and should not be interpreted as necessarily representing the official policies of the Interior Department's Bureau of Mines or of the U.S. Government.

**W.A. WAHLER
& ASSOCIATES**

P.O. BOX 10023 • 1023 CORPORATION WAY, PALO ALTO, CALIFORNIA 94303 • (415) 968-6250

February 20, 1973
Project 0700

Mr. W. Ross Wayment
Chairman, Department of Interior Task Force
to Study Coal Waste Hazards
U. S. Bureau of Mines
C Street Between 18th and 19th Streets, N.W.
Room 4528
Washington, D.C. 20240

Dear Mr. Wayment:

On February 26, 1972, a coal refuse dam, owned and operated by the Buffalo Mining Company, failed near Saunders, West Virginia. The resulting flooding of the Buffalo Creek Valley had national ramifications. The immediate consequences of the flooding were the deaths of 118 persons and 7 reported missing, the loss of over 500 homes, and extensive flood damage to other property in Buffalo Creek Valley.

In fulfillment of our commitments under Contract No. S0122084 with the U. S. Bureau of Mines, we have completed our investigation of the embankment failure. This report, contained in two volumes, presents a comprehensive analysis of the failure based on a thorough program of subsurface exploration and sampling, field and laboratory testing, and engineering analyses. Data from all available sources were reviewed and integrated to arrive at our conclusions regarding the most probable mode of failure.

We greatly appreciate the opportunity to have performed this most interesting and significant investigation for the Bureau of Mines. The data gathered during this investigation should significantly improve the understanding of existing problems associated with the use of coal waste for construction of impounding facilities. The data developed in our studies, when combined with results of other work which we are currently performing for the Bureau of Mines, will provide a significant contribution of new engineering knowledge which can be applied to minimize future coal waste disposal hazards.

Very truly yours,

W. A. WAHLER & ASSOCIATES

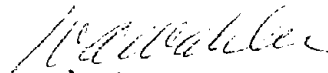
W. A. Wahler
President



MIDDLE FORK VALLEY FEBRUARY 28, 1972 PHOTOGRAPH COURTESY OF WEST VIRGINIA DEPA

W A WAHLER
& ASSOCIATES



FORK VALLEY • FEBRUARY 28, 1972 PHOTOGRAPH COURTESY OF WEST VIRGINIA DEPARTMENT OF HIGHWAYS

ANALYSIS OF
COAL REFUSE DAM FAILURE
MIDDLE FORK BUFFALO CREEK
SAUNDERS, WEST VIRGINIA

TABLE OF CONTENTS

VOLUME 1 - TEXT

		<u>Page</u>
CHAPTER I	INTRODUCTION	
	A. General	I-1
	B. Authorization for Investigation	I-1
	C. Purpose of Investigation	I-2
	D. Scope of Investigation	I-3
	E. Organization of Report	I-4
CHAPTER II	SUMMARY AND CONCLUSIONS	
	A. Summary of Investigation	II-1
	B. Conclusions Regarding Embankment Failure	II-3
CHAPTER III	AREA DESCRIPTION	
	A. General	III-1
	B. Topography	III-1
	C. Geology	III-2
	D. Hydrology	III-4
CHAPTER IV	MINE AND PLANT DESCRIPTION AND OPERATION	
	A. General	IV-1
	B. Buffalo Mining Company	IV-2
	C. No. 5 Mine Coal Preparation Plant	IV-3
	D. Operation of Mine and Coal Plant	IV-4
CHAPTER V	DESCRIPTION OF REFUSE DAMS	
	A. Introduction	V-1
	B. Construction Methods	V-2
	C. Construction History	V-4
	D. Prefailure Conditions	V-16
	E. Reservoirs	V-19
	F. Spillway Provisions	V-22
CHAPTER VI	POSTFAILURE APPEARANCE OF SITE	
	A. Introduction	VI-1
	B. Description of Site	VI-1
	C. Interpretation of Postfailure Appearance	VI-5

		<u>Page</u>
CHAPTER VII	REFUSE DAM FAILURE	
	A. General	VII-1
	B. Materials Properties	VII-1
	C. Climatological Data	VII-12
	D. Reservoir Conditions	VII-13
	E. Failure Analyses	VII-19
	F. Most Probable Mode of Failure	VII-41
CHAPTER VIII	FLOOD FLOW AND MATERIALS DISTRIBUTION	
	A. Sources of Flood Water	VIII-1
	B. Probable Role of Refuse Dams and Bank in Flood Development and Distribution	VIII-1
	C. Flood Hydrographs	VIII-5
	D. Flood Attenuation	VIII-6
	E. Materials Distribution	VIII-7
CHAPTER IX	BIBLIOGRAPHY	IX-1

TABLES

<u>Table No.</u>		<u>Page</u>
IV-1	Buffalo Mining Company, No. 5 Coal Plant Operations	IV-3
V-1	Chronological Summary of Construction, Failures, and Repairs--Middle Fork Valley, 1947-1972 (2 sheets)	V-14
V-2	Summary of Pool Data, Middle Fork Valley	V-20
V-3	Summary of Spillway History, Middle Fork Valley	V-23
VII-1	Reservoir Level Rise for Pool 3, February 22-26, 1972	VII-18
VIII-1	Floods in Southwestern West Virginia (2 sheets)	VIII-2

FIGURES

<u>Figure No.</u>		<u>Following Page</u>
	Frontispiece	
III-1	Map of Logan County, West Virginia	III-1
III-2	Buffalo Creek and Vicinity	III-1
III-3A...	Generalized Geologic and Exploration Map, Middle Fork Valley, Buffalo Creek Confluence	III-2

6

FIGURES (Continued)

<u>Figure No.</u>		<u>Following Page</u>
III-3B	Generalized Geologic and Exploration Map, Middle Fork Valley, Refuse Bank to Lower Pool 3	III-2
III-3C	Generalized Geologic and Exploration Map, Middle Fork Valley, Upper Pool 3 to No. 5 Mine Area	III-2
III-4	Stratigraphic Column at Dam No. 3	III-3
III-5	Typical Kanawha Series Outcrops	III-4
IV-1	Buffalo Mining Company Materials Flow Chart	IV-6
V-1	Pedestal Remnant of Dam No. 1	V-3
V-2	Wall of Dam No. 2 Breach Area	V-3
V-3	Downstream Face of Dam No. 2	V-3
V-4	Exploration Trench Walls, Dam No. 3	V-4
V-5	Diagrammatic Cross Section, Dam No. 3	V-4
V-6	Bald Knob Quadrangle, Middle Fork Valley Portion	V-5
V-7	Diagrammatic Sketch, Middle Fork Valley, Late 1947	V-5
V-8	Diagrammatic Sketch, Middle Fork Valley, April 1960	V-5
V-9	Diagrammatic Sketch, Middle Fork Valley, November 28, 1962	V-6
V-10A-C	Topographic Map and Cross Section, 1968	V-7
V-11A-D	Diagrammatic Sketch, Dam No. 2 Construction Sequence: December 1966 to Late 1967	V-8
V-12	Diagrammatic Sketch, Middle Fork Valley, Early 1968	V-8
V-13	D. S. Dasovich's Sketch of Proposed Dam No. 3, February, 1968	V-8
V-14A-H	Diagrammatic Sketch, Dam No. 3 Construction Sequence: Mid-1968 to February 1972	V-9
V-15	Upper Pool 3 to Dam No. 4 Area	V-13
V-16	Generalized Prefailure Topography, Middle Fork Valley, Early 1972	V-16

FIGURES (Continued)

<u>Figure No.</u>		<u>Following Page</u>
V-17	Prefailure Cross Section, Middle Fork Valley, Early 1972	V-16
V-18	Aerial View of Middle Fork Valley, February 28, 1972 With Outline of Prefailure Configuration	V-16
V-19	Diagrammatic Sketch, Middle Fork Valley, Early 1972	V-16
VI-1	Aerial View of Notch in Refuse Bank, March 1972	VI-2
VI-2	Haul Road Above Notch in Refuse Bank	VI-2
VI-3	Sludge Raft in the Flood Alluvium Filling Pool 1	VI-2
VI-4	Aerial View of Middle Fork Valley Looking Downstream, Above Dam No. 2	VI-2
VI-5	Patches of Pool 2 Sludge on Refuse Bank	VI-2
VI-6	High Water Line on Left Side of Refuse Bank	VI-2
VI-7	Left Side of Middle Fork Valley From Refuse Bank	VI-2
VI-8	Pool 2 Sludge and Translated Dam No. 3 Embankment Materials	VI-3
VI-9	Major Blocks of Pool 2 Sludge in "Roiled" Area	VI-3
VI-10	Gentle Folds in "Roiled" Area	VI-3
VI-11	Pedestals in "Roiled" Area	VI-3
VI-12	Entrance to Small Subsurface Channel in Pool 2 Sludge	VI-3
VI-13	Contact of Pool 2 Sludge and Translated Dam No. 3 Embankment Materials	VI-3
VI-14	Contact of Pool 2 Sludge and Translated Dam No. 3 Embankment Materials	VI-3
VI-15	Stream Bank South of Drill Hole S-19	VI-3
VI-16	Downstream Portion of Left Abutment Remnant of Dam No. 3	VI-4
VI-17	Central and Upstream Portion of Left Abutment Remnant of Dam No. 3	VI-4

FIGURES (Continued)

<u>Figure No.</u>		<u>Following Page</u>
VI-18	Right Abutment Remnant of Dam No. 3	VI-4
VI-19	Aerial View, Middle Fork Valley, Looking Downstream Above Pool 3 With Outline of Prefailure Configuration	VI-4
VI-20	Geologic and Exploration Map	VI-5
VI-21	Geologic Cross Section A-A', Middle Fork Valley	VI-6
VI-22	Geologic Cross Section B-B', Dam No. 3	VI-7
VI-23	Generalized Prefailure Cross Section C-C'	VI-7
VI-24	Transverse Section D-D', Dam No. 2	VI-7
VI-25	High Water Line Evidence	VI-7
VI-26	Diagrammatic Sketch, Middle Fork Valley, Postfailure	VI-7
VI-27	Stream Terraces	VI-7
VII-1	Gradation Summary, Embankment Materials	VII-3
VII-2	Dry Density Frequency Distribution, Embankment Materials, Laboratory Samples	VII-4
VII-3	Dry Density Frequency Distribution, Embankment Materials, Field and Laboratory Samples	VII-4
VII-4	Slaking Shale	VII-5
VII-5	Shear Strength Parameters, Embankment Materials	VII-6
VII-6	Gradation Summary, Foundation Materials	VII-8
VII-7	Dry Density Frequency Distribution, Foundation Materials	VII-8
VII-8	Shear Strength Parameters, Foundation Materials	VII-11
VII-9	Rainfall in Southwestern West Virginia, February 24-26, 1972	VII-12
VII-10	Apparent Pool 3 Water Level Rise, February 24-26, 1972	VII-18
VII-11	Location of Engineering Analyses Sections	VII-19

FIGURES (Continued)

<u>Figure No.</u>		<u>Following Page</u>
VII-12	Dam No. 3, Section E-E'	VII-19
VII-13	Dam No. 3, Section F-F'	VII-19
VII-14	Recovered Spillway Pipes, Dam No. 3	VII-21
VII-15	Area-Capacity Curve, Pool 3	VII-26
VII-16	Flow Nets, Normal Level Pool 3, Section E-E'	VII-28
VII-17	Flow Nets, Maximum Level Pool 3, Section E-E'	VII-28
VII-18	Flow Nets, Normal Level Pool 3, Section F-F'	VII-28
VII-19	Flow Nets, Maximum Level Pool 3, Section F-F'	VII-28
VII-20	Determination of Piezometric Head, Maximum Reservoir Level	VII-35
VII-21	Stability Analysis, Dam No. 3, Section E-E'	VII-36
VII-22	Stability Analysis, Dam No. 3, Section F-F'	VII-36
VII-23A-H	Diagrammatic Sketches, Most Probable Mode of Failure	VII-43
VIII-1	Flood Hydrographs	VIII-5
VIII-2	Fatality Distribution	VIII-7
VIII-3	Peak Flood Discharge	VIII-7

VOLUME 2 - APPENDICES

APPENDIX A

		<u>Page</u>
TEXT	FIELD INVESTIGATION	
	A. Introduction	A-1
	B. Auger Drilling	A-1
	C. Field Permeability Tests	A-5
	D. Field Density Tests	A-5
	E. Cone Penetrometer and Vane Shear Tests	A-6
	F. Backhoe Pits and Bulldozer Trenches	A-8
	G. Aerial Photography and Topographic Mapping	A-8
	H. Geologic Mapping	A-9
	FIGURES	
<u>Figure No.</u>		
A-1	Photograph Locations	
A-2	Exploration Drilling Equipment	
A-3	Field Investigation and Typical Samples	
A-4	Backhoe and Bulldozer Trenches	
A-5	Field and Vane Shear Penetration Test Results (10 sheets)	
A-6	Backhoe Pit Logs (3 sheets)	
	TABLES	
<u>Table No.</u>		
A-1	Drill Hole Summary (3 sheets)	
A-2	Summary of Field Density Test Results (4 sheets)	
A-3	Penetration and Vane Shear Test Results (4 sheets)	
	Drill Logs and Water Pressure Test Results:	
	<u>Hole No.</u>	<u>No. of Sheets</u>
	S-1	1
	S-2	2
	S-3	4
	S-4	3
	S-5	3
	S-6	4
	S-7	3
	S-8	2
	S-9	3
	S-10	3
	S-11	3
	S-12	4
	S-13	3
	S-14	3

TABLES (continued)

Table No.

Drill Logs and Water Pressure Test Results (continued):

<u>Hole No.</u>	<u>No. of Sheets</u>
S-15	2
S-16	2
S-17	2
S-18	2
S-19	2
S-20	1
S-21	2
S-22	1

A-4	Key for Exploration Logs (Foldout for Interpretation of Logs) Field Permeameter Test Results for Hole Nos. FP-1A through FP-14A (15 sheets following Table A-4)
-----	---

APPENDIX B

<u>TEXT</u>		<u>Page</u>
	LABORATORY INVESTIGATION	
A.	General	B-1
B.	Index Properties Testing	B-2
C.	Engineering Properties Testing	B-4

FIGURES

Figure No.

B-1	In Situ Water Content and Dry Unit Weights (2 sheets)
B-2	Gradation Test Results (25 sheets)
B-3	Atterberg Limits-Plasticity Data (3 sheets)
B-4	Summary of Specific Gravity Results (2 sheets)
B-5	Compaction Test Results (13 sheets)
B-6	Triaxial Test Results (15 sheets)
B-7	Summary of Permeability Test Data

PHOTOPLATES

<u>Photoplate No.</u>		<u>Following Page</u>
B-1	Triaxial Saturation Bay	B-5
B-2	Laboratory Sample Fabrication	B-6

APPENDIX C

TEXT	SUPPORTING DATA	<u>Page</u>
	FIGURES	C-1
<u>Figure No.</u>		
C-1	Topographic Map, Middle Fork Valley, November 28, 1962	
C-2	Topographic Map, Middle Fork Valley, December 1966	
C-3	Calendar of Middle Fork Valley Dam and Pool Activity, 1960-1972	
	TABLES	
<u>Table No.</u>		
C-1	Construction Methods, Middle Fork Valley Refuse Bank and Dams (3 sheets)	
C-2	Daily Weather Conditions, Southwestern West Virginia January and February 1972 (2 sheets)	
C-3	Weather Condition Summary, Southwestern West Virginia January and February 1972 (1 sheet)	
C-4	Chronological Listing of Visits to Dam No. 3, Prior to Failure, February 22 to February 26, 1972 (4 sheets)	

CHAPTER I

INTRODUCTION

A. GENERAL

On February 26, 1972, a coal refuse dam, owned and operated by the Buffalo Mining Company, failed near Saunders, West Virginia. The resulting flooding of the Buffalo Creek Valley had national ramifications. The immediate consequences of the flooding were the deaths of 118 persons and 7 reported missing, the loss of over 500 homes, and extensive flood damage to other property in Buffalo Creek Valley.

Several investigations were started immediately after the disaster; some were under government auspices, while others were initiated by groups of concerned citizens. These investigations relied primarily on personal observations, and eyewitness reports, although the U.S. Army Corps of Engineers and the U.S. Geological Survey undertook limited field and laboratory testing. These original investigations contributed to an understanding of the Buffalo Creek Flood. The principal contributions of this report, prepared by W. A. Wahler and Associates of Palo Alto, California, are the presentation of a comprehensive view of the failure with essential data integrated from many sources, and an analysis of the failure based on a thorough program of subsurface exploration and sampling, field and laboratory testing, and engineering analyses.

B. AUTHORIZATION FOR INVESTIGATION

Mr. Hollis M. Dole, Assistant Secretary of the Interior, by memorandum dated March 2, 1972, established "a joint U.S. Bureau of Mines-

Geological Survey Task Force to study and analyze hazards associated with the disposal and storage of coal mine waste materials," The first problem listed to be undertaken by the Task Force was an "Analysis of the February 26 failure at Lorado, West Virginia." The community of Lorado figured prominently in the initial press coverage of the disaster, but subsequently, as in the title of this report, the failure was referred to as having occurred at or near Saunders, the community closest to the site of the failure, and the first community to be inundated by the flood.

On March 12, 1972, a Task Force report entitled "Preliminary Analysis of the Coal Refuse Dam Failure at Saunders, West Virginia, February 26, 1972" was published. Subsequently, the Bureau of Mines contracted with W. A. Wahler and Associates (Contract No. S0122084) to undertake a study known as the "Emergency Coal Waste Disposal System Hazard Study." As part of the work under the contract, W. A. Wahler and Associates was directed to "undertake an in-depth investigation, study and evaluation of the consequences of the February 26, 1972, coal refuse dam failure at Saunders, West Virginia." W. A. Wahler and Associates has prepared this report under that authorization.

C. PURPOSE OF INVESTIGATION

The purpose of investigating the conditions preceding the Saunders coal refuse dam failure, the possible modes of the failure, and the consequences of the resulting flooding was primarily to provide an understanding of what actually occurred so that the resulting data could be applied by interested parties toward properly designed coal waste embankments. In addition, results of this study assisted in identifying other sites where similar conditions existed, thereby constituting a potential threat, and in providing a basis for planning corrective measures. It was not the purpose of this study, or of this

report, to assess blame or indicate liability on the part of any of the parties involved, but rather to record the nature of the failure, documenting it in a manner that will help improve future coal waste disposal practices. This study represents one of the first significant attempts to analyze in detail any coal waste disposal system from the standpoint of flood hazard and embankment stability. The data generated in this effort are basic to future studies of the hazards associated with the disposal and storage of coal mine waste material.

D. SCOPE OF INVESTIGATION

The scope of the investigation conducted by W. A. Wahler and Associates included the following activities:

1. Collection and review of basic information and reports available from private and government sources regarding the Buffalo Mining Company's mine operation and waste disposal procedures, embankment construction practices, embankment failures, and the subsequent flood.
2. Collection and review of available topographic, geologic, and hydrologic information pertinent to analysis of the failure and its consequences.
3. Field exploration and materials sampling and testing at the dam failure sites to obtain information regarding the in-place properties of the embankment and foundation materials involved in the failure.
4. Laboratory testing to determine the basic index and engineering properties of the foundation and embankment materials.

5. Engineering analyses, using the information produced in steps 1 through 4, to identify the probable causes of the embankment failures and their share of the consequences.
6. Compilation of the results in this report.

Within the scope of this work, we have critically reviewed numerous other reports which are listed in Chapter IX. Considerable effort was expended on correlating and cross-checking many aspects of the observations and opinions of the authors of these reports. We have attempted to present our findings concerning the failure in an objective manner that is consistent not only with our field observations and engineering analysis, but also with the major observations of others.

E. ORGANIZATION OF REPORT

This report is presented in two volumes. The first volume, consisting of Chapters I through IX, contains a summary and conclusions of the investigation, drawn from the body of the report; pertinent information on the Buffalo Mining Company's plant and its operation; a discussion of the geologic and engineering characteristics of the Buffalo Creek area; a description of coal refuse placement in Middle Fork Valley and its effects on the probable physical characteristics of the embankments and foundations; an analysis of the postfailure appearance of the site; a discussion of the probable mode of failure of the refuse dams; and a discussion of the consequences of the resulting flood. Pertinent tables, illustrations and references are included in this volume. The second volume, consisting of Appendices A, B, and C, contains basic geologic and engineering data supporting the discussions and conclusions in volume 1. These appendices include data developed during the field and laboratory investigations, and other supporting information.

CHAPTER II

SUMMARY AND CONCLUSIONS

This chapter presents a summary of the salient portions of W. A. Wahler and Associates' detailed investigation of the February 26, 1972 coal refuse dam failure near Saunders, West Virginia, and outlines the principal conclusions which have been drawn therefrom. A better understanding of our findings can be gained by reading the entire text of this report; however, in order to make our principal findings more readily accessible to the reader, they are presented in condensed form below.

A. SUMMARY OF INVESTIGATION

1. Basic data were collected during the field investigation conducted from March through September 1972. Laboratory investigations extended through November 1972. Office research and analyses were conducted through December 1972.
2. The field investigation consisted of field mapping, aerial photography and associated surveying for ground control, subsurface exploration and sampling of materials by means of 60 rotary drill holes totaling 3,303 feet, 11 backhoe pits and 2 bulldozer trenches, 14 field permeability tests, 44 field density tests, and 9 penetration and 10 vane shear probes.
3. On the basis of all data gathered, an interpretation was made of the prefailure configuration of the coal waste disposal embankments and impoundments which existed on Middle Fork of Buffalo Creek prior to February 26, 1972. It was possible to do this to the degree necessary to perform reliable engineering analyses of the modes of failure which might have occurred.

18

4. A laboratory investigation was conducted which included the following tests on samples obtained during the field investigation from the remnants of the dams and the surrounding area:

<u>Type of Test</u>	<u>Number of Tests</u>
Natural Water Content and Dry Density	75
Grain Size Distribution	89
Atterberg Limits	15
Specific Gravity	57
Compaction	13
Triaxial Shear	44
Permeability	29
Determination of Critical Seepage Gradient in Foundation Sludge	1

Tests were conducted both in a portable field laboratory established in Logan, West Virginia, and in our main soils laboratory at Palo Alto, California. The important engineering properties of the coarse coal waste embankment and foundation sludge materials that were determined from the laboratory investigation and used in our analyses are summarized below:

<u>Engineering Property</u>	<u>Foundation Sludge</u>	<u>Embankment</u>
Dry Density (pcf)	54	90
Wet Density (pcf)	78	106
Specific Gravity	1.43	1.95
Permeability Ratio (Horizontal to Vertical)	25:1 to 100:1	1:1
Shear Strength Parameters		
Effective Stress	$C' = 0$ $\phi' = 37^\circ$	$C' = 500$ psf $\phi' = 34^\circ$
Total Stress	$C = 1100$ psf $\phi = 16.5^\circ$	$C = 700$ psf $\phi = 17^\circ$

5. All known information pertinent to the site conditions and the failure was reviewed and analyzed for data which could help establish conditions preceding the failure, and which might help in analyzing the failure itself. One of the significant disclosures of this review was that, during the construction of Dams 2 and 3, at least two different types of foundation failures (piping and shear) occurred. These failures were subsequently repaired by end-dumping of coarse coal waste into the failure areas. As a matter of fact, each of the dams in Middle Fork Valley had a history of minor failures prior to the catastrophic failure of Dam No. 3 on February 26, 1972.

6. Engineering analyses were conducted to assess the stability of Dam No. 3 under "normal" operating and flood stage conditions. Included in these analyses were permeability and seepage studies and numerous determinations of factors of safety against failure for different combinations of embankment and foundation cross sections, materials permeability properties, reservoir water levels, and failure surface configurations. Both circular arc and sliding wedge or block type failure surfaces were analyzed using computerized methods. Results of these analyses coincide well with and fully support the findings of the field investigation and the conclusions concerning the most probable mode of failure presented herein.

B. CONCLUSIONS REGARDING EMBANKMENT FAILURE

1. The foundation material upon which Dams 2 and 3 were constructed consisted of relatively thick deposits of fine-grained coal sludge wastes. These materials possessed

physical characteristics, principally a low unit weight and high susceptibility to erosion and piping, that were extremely detrimental to the long-term stability of these dams. The results of laboratory testing have confirmed the susceptibility of the foundation sludge to a piping type of failure mechanism, even when the materials are densified. Specialized engineering techniques are required to safely utilize this material in either a foundation or an embankment whenever seepage or saturation may be involved.

Even under "normal" water level conditions which existed in Pool 3 prior to the series of storms which preceded the failure, a major portion of Dam No. 3 was in a precarious state of stability. Testimony revealed that foundation boils occurred in the Pool 3 sludge a short time after completion of Dam No. 3 and intermittently thereafter up to the time of its catastrophic failure. The significance of these occurrences, which were due to excessive exit seepage gradients and probably associated with piping, apparently was not recognized by those connected with the construction and operation of the facilities.

2. Results of our review of available information and detailed field investigation of the sites of Dams 1, 2, and 3 confirm that all three embankments were built by methods not in conformance with current practices of the civil engineering profession in the design and construction of water retention dams. The dams were built largely by end-dumping of refuse from trucks with grading by bulldozers to create a relatively smooth working surface. From the data we examined, it appears that the dams were not designed or engineered on the basis of a thorough knowledge of the engineering properties of coal processing refuse. Further, the dams were not constructed

under any system of close supervision or control. Although the dams did receive some compaction from truck wheel loads and bulldozer track loads, this compactive effort was not systematically controlled or referenced to any standard of performance or specific knowledge of the compaction characteristics of the coal refuse used.

3. Inadequate conveyance facilities were provided to carry natural runoff safely past the embankments. The facilities that were provided were installed in a manner inconsistent with generally accepted engineering practice for water-impounding structures. Furthermore, no adequate means were provided for safely controlling internal seepage through the embankments and foundations.
4. A review of the climatological data indicates that the storm of February 25-26, 1972, was not of a severe nature and would be classified as having a two- or three-year probability of recurrence. The degree of storm severity is further demonstrated by the fact that it did not cause unusually high flows in other streams in the surrounding area. It is concluded, therefore, that the sudden release of the accumulated water behind the coal waste dams on the Middle Fork at Saunders was the principal source of the catastrophic flooding on Buffalo Creek.
5. Each of the dams on Middle Fork, except Dam No. 4, was provided with either a single or multiple-pipe spillway of 24- or 30-inch diameter. By comparing the estimated runoff into each reservoir with the maximum discharge capacity of the various spillway pipes, it is concluded that Dams 1 and 2 did not fail by overtopping prior to the failure of Dam No. 3. However, it is highly probable that because of insufficient spillway capacity, an overtopping failure of Dam No. 3 would have occurred had the dam not failed by other means.

6. Because of the presence of boils in the Pool 2 sludge downstream of the toe of Dam No. 3, even under normal operating water level conditions, it is concluded that foundation piping was occurring, at least on a limited basis, at the time of the catastrophic failure. As the rise in level of Pool 3 occurred, the increase in foundation seepage exit gradient was conducive to the development of both piping and liquefaction in the area of the downstream toe. However, neither the field investigation nor the results of our analytical studies have disclosed evidence to indicate that one or more erosion channels had developed in the foundation material to the extent necessary to cause a catastrophic collapse of a major portion of the dam embankment into a large subsurface erosion channel. It is therefore concluded that piping, while it undoubtedly occurred to some extent in the dam foundation, was not the primary cause of the ultimate dam collapse.

7. Compelling evidence from the field investigation and detailed engineering analyses has led us to conclude that the most probable modes of failure for Dams 1, 2, and 3 were as follows:

Dam No. 3 failed prior to the breaching of both Dam No. 1 and Dam No. 2, and the failure of Dam No. 3, with the sudden release of stored water, was the direct cause of the failure of the other two structures. The initial failure occurred in the downstream section of Dam No. 3 and consisted of a massive slide movement involving approximately 130,000 cubic yards of embankment material. Calculated factors of safety for the highest reservoir level at Elevation 1,753, which probably occurred just prior to failure, indicate a

gross instability of that portion of the dam underlain by foundation sludge material. This condition applied to the central 270 feet of the dam, as measured across the hollow. The initial slide occurred in such a manner that the embankment physically displaced Pool 2 reservoir sediments, which were acting as a semi-viscous fluid because of the relatively high internal pore water seepage pressures, and translated a large block of these sediments onto the left side of Dam No. 2.

Associated with the massive displacement of embankment materials into Pool 2, was the initial overtopping of Dams 2 and 1 by the reservoir water displaced from Pool 2. This surging of water over the crest of Dam No. 2, which had perhaps only four feet of freeboard, most likely initiated the breach near the right abutment.

Very soon after the initial failure, Dam No. 3 continued to fail rapidly by progressive action. Because the initial failure undoubtedly created a relatively steep head scarp, that portion of the embankment not involved with the initial failure was left standing with the phreatic surface emerging high on the exposed oversteepened face. The resulting condition of the embankment was very unstable and the remaining portions of the embankment commenced to slide into the void created by the initial failure. It is impossible to state exactly how long this progressive failure mechanism took to develop, but total failure probably developed in less than 15 minutes.

Once the failure had progressed upstream until only 100 to 120 feet of the embankment were left standing, as measured from the upstream toe, the analyses show that the remaining

section of the embankment then failed violently, thereby allowing the first rush of Pool 3 water to start its destructive action. The initial release of water was apparently confined, or nearly so, toward the right side of the valley as it progressed downstream. As water flowed through the breach of Dam No. 3, embankment materials that had slumped as a result of the progressive failure were transported into the Pool 2 area. As the heavily laden flood waters hit Dam No. 2, its breach, started by the initial overtopping, was probably widened and deepened. The initial flood wave then continued downstream, overtopping and destroying the small Dam No. 1 until the water reached the narrow portion of the valley formed between the refuse bank and the No. 5 Mine Road. The initial surge of this flood wave, as it hit the burning refuse bank, caused the explosions reported by numerous observers.

After the flood wave reached the refuse bank, the constrictions in the valley cross section caused a backup of water, and the high water lines downstream of Dam No. 3 were formed. As water continued to flow through the initial breach of Dam No. 3, the failure of the remaining portions of the dam progressed toward the right and left abutments.

After developing the mode of failure described above, the remaining Pool 3 water continued to flow through the ever-widening breach of Dam No. 3. Relatively minor readjustments of major translated blocks of sediment and embankment materials probably occurred at this time, followed by the final emptying of Pool 3.

A series of eight diagrammatic sketches depicting the failure sequence described above is presented on Figures VII-23A through VII-23H.

CHAPTER III

AREA DESCRIPTION

A. GENERAL

Logan County is in the center of the southern West Virginia bituminous coal field. Logan, the county seat, is about 70 miles southwest of Charleston (Figure III-1). The town of Man, about 12 road miles south-east of Logan, is at the confluence of Buffalo Creek and the Guyandotte River. Buffalo Creek Valley extends east-northeast from Man a distance of about 15 miles, having its headwaters at the point common to Logan, Boone, and Wyoming counties (Figure III-2).

B. TOPOGRAPHY

Southwestern West Virginia is essentially an extensively dissected plateau which slopes gently to the northwest. Elevations in Logan County range from about 600 feet at the Guyandotte River at the boundary with Lincoln County to about 2,850 feet at the boundary point common to Logan, Boone, and Wyoming counties. The Guyandotte River is the major stream in the area; it flows northwesterly and joins the Ohio River near Huntington.

The topography of southwestern West Virginia, and the Buffalo Creek area, is characterized by rugged hills. The action of numerous small streams has completely dissected the Appalachian Plateau and created a region of high ridges and sharp, V-shaped valleys. The heavily forested valley walls generally slope at about 2.0 H to 1.0 V; a dense growth of bushes and small trees comprises most of the ground cover. The surrounding hills attain a maximum elevation of 2,850 feet above sea

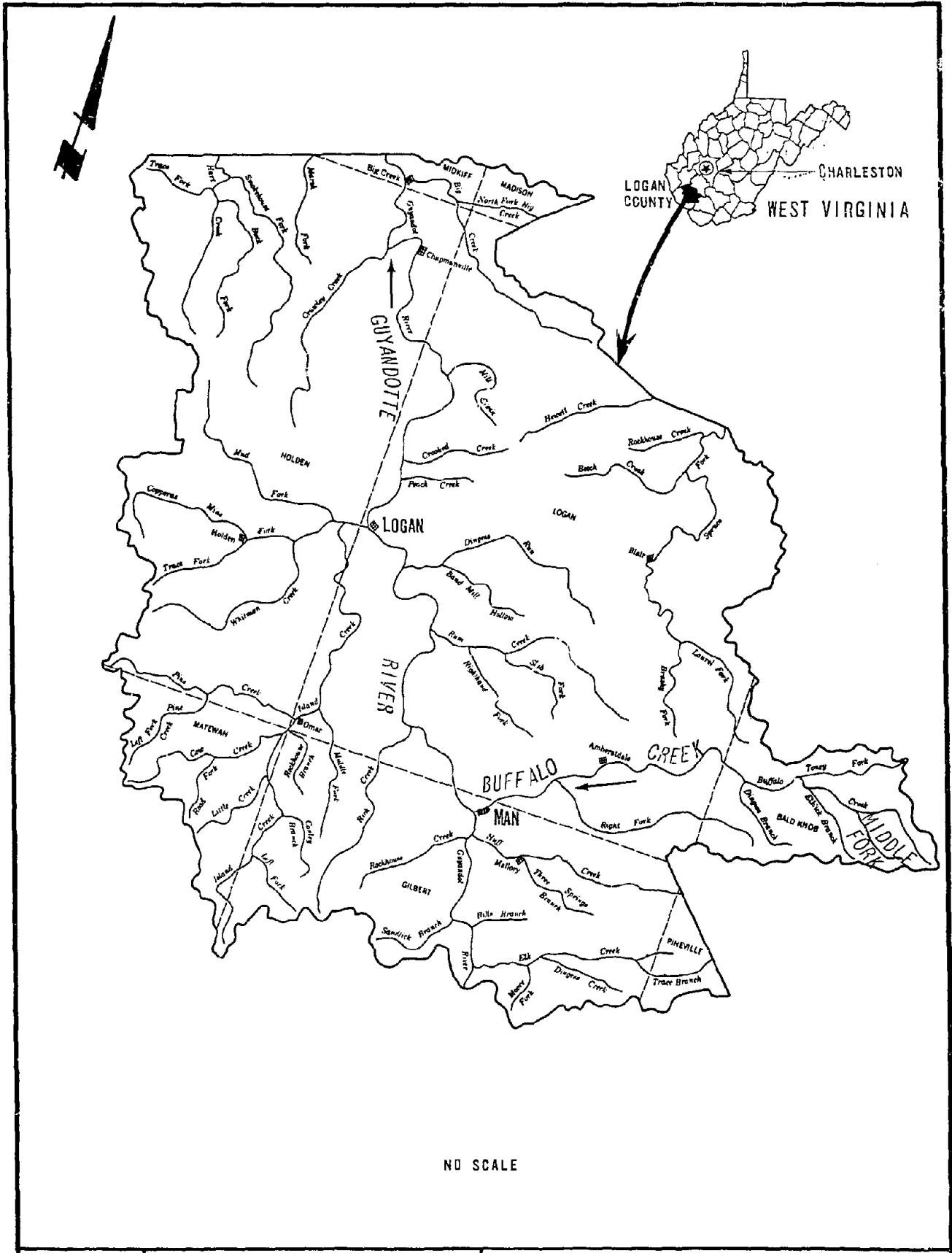

NO SCALE

W. A. WAHLER & ASSOCIATES	COAL REFUSE DAM FAILURE SAUNDERS, WEST VIRGINIA		LOGAN COUNTY MAP	
	PROJECT NO. 0700	DATE NOVEMBER 1972	DRAWING NO. 111-1	
PALO ALTO • NEWPORT BEACH • CALIF.				

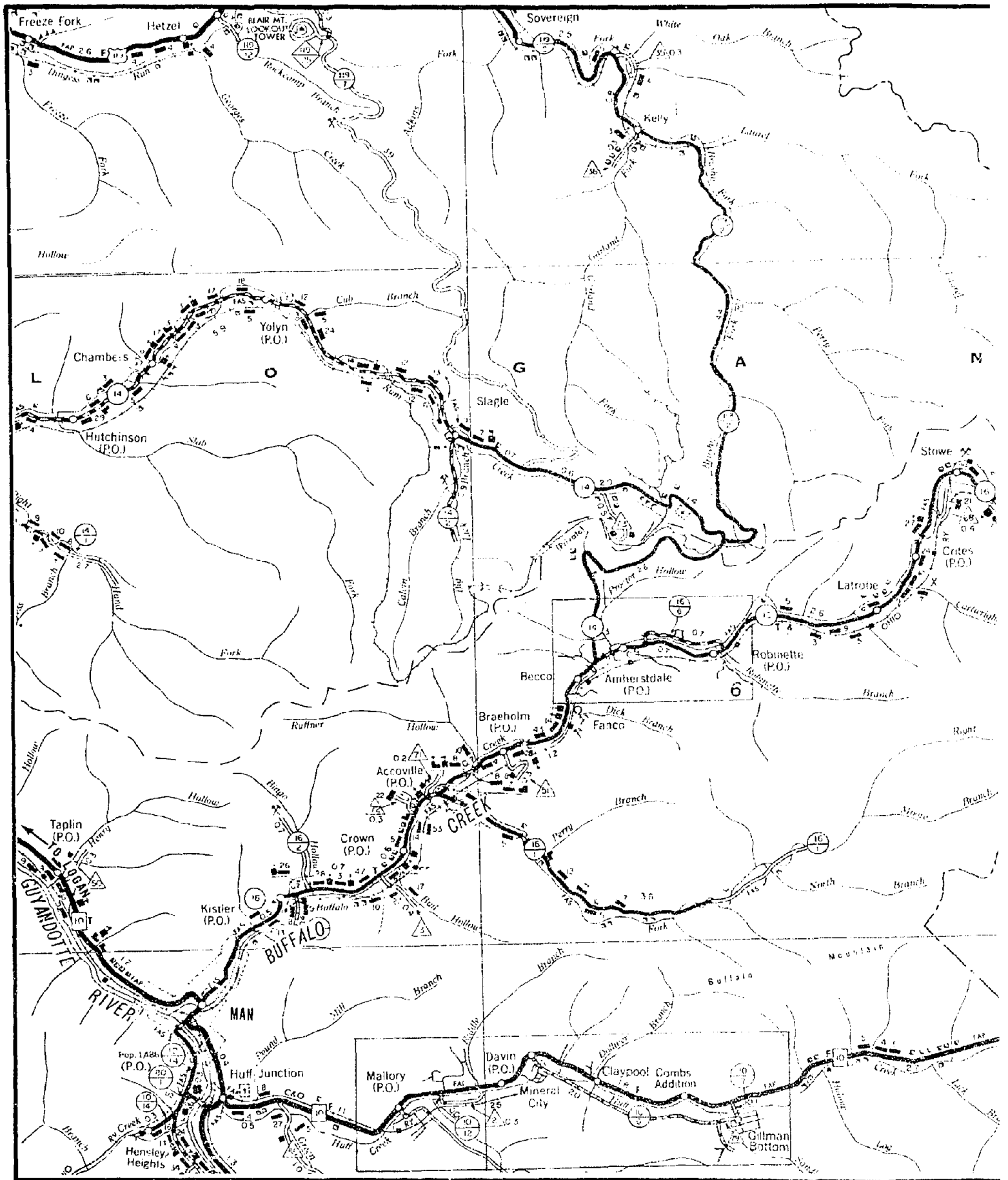

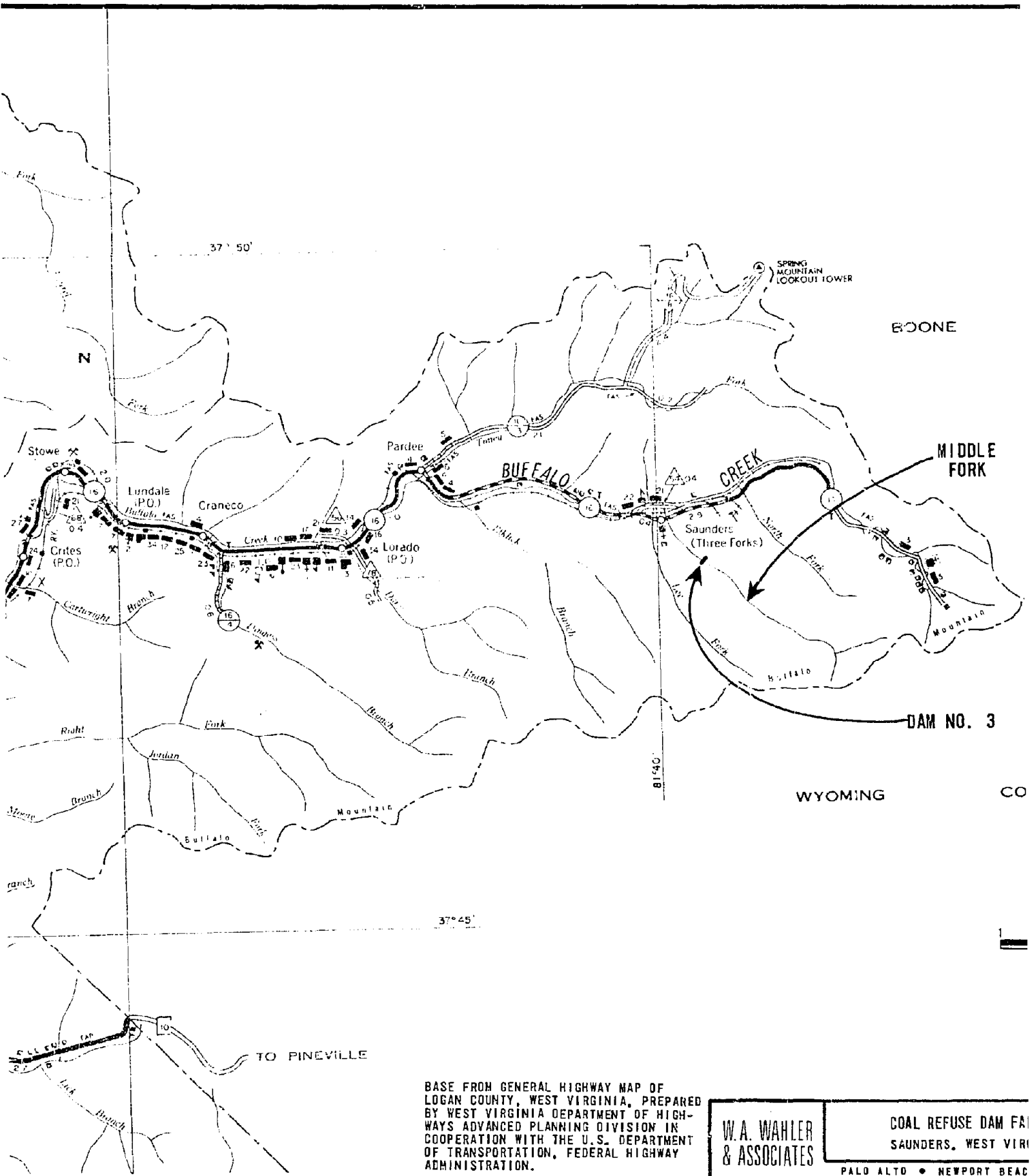

BASE FROM GENERAL HIGHWAY MAP OF LOGAN COUNTY, WEST VIRGINIA, PREPARED BY WEST VIRGINIA DEPARTMENT OF HIGHWAYS ADVANCED PLANNING DIVISION IN COOPERATION WITH THE U. S. DEPARTMENT OF TRANSPORTATION, FEDERAL HIGHWAY ADMINISTRATION.

W. A. WAHLER & ASSOCIATES

COAL REFUSE DAM FAI SAUNDERS, WEST VIRI

PALO ALTO • NEWPORT BEAC

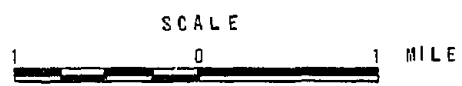
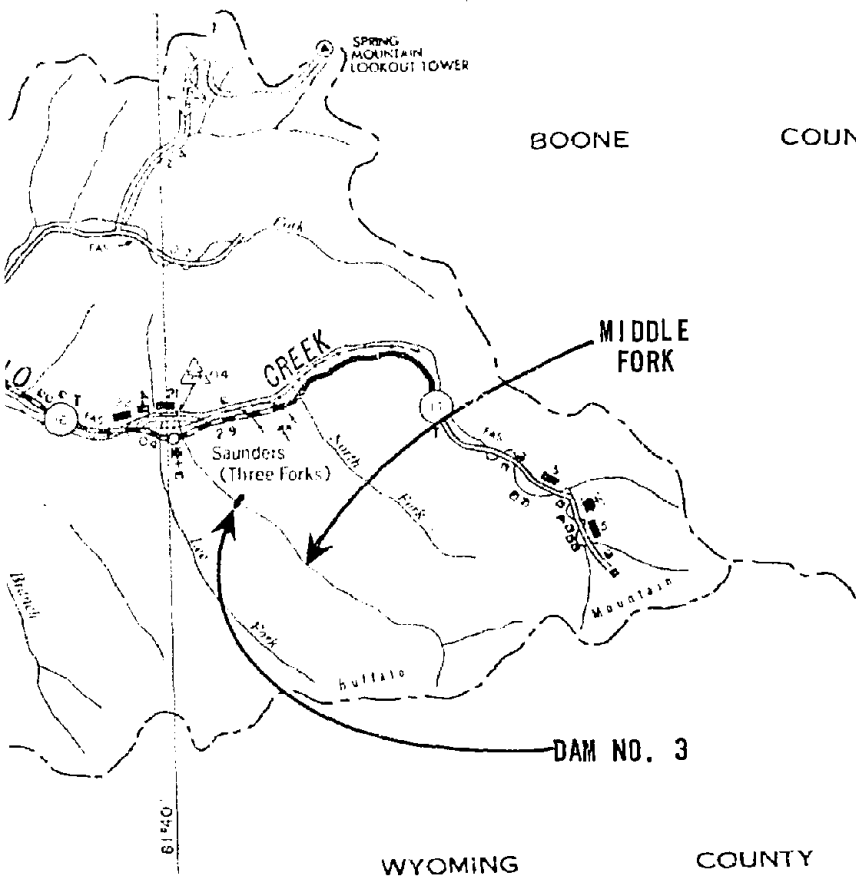

HIGHWAY MAP OF
 VIRGINIA, PREPARED
 DEPARTMENT OF HIGH-
 WING DIVISION IN
 IE U.S. DEPARTMENT
 FEDERAL HIGHWAY

W.A. WAHLER & ASSOCIATES	COAL REFUSE DAM FAILURE SAUNDERS, WEST VIRGINIA		BUFFALO CREEK AND VICINITY	
	PALO ALTO • NEWFORT BEACH • CALIF.	PROJECT NO. 0700	DATE NOVEMBER 1972	FIGURE NO. 111-2

level, and their summits are roughly concordant with the old plateau surface. Total relief from valley floors to ridge crests is on the order of 1,000 to 1,300 feet. There is very little level or gently sloping upland topography, and valley floors are, in general, very narrow with minor alluvial terrace development. Indeed, flat land of any kind is scarce throughout the region. The major stream profiles along valley floors are surprisingly smooth considering the rugged topography. Waterfalls or other disruptions in the gradients of larger streams are uncommon.

As shown on the Lorado and Amherstdale 7½-minute U.S. Geological Survey quadrangles, the flood plain of Buffalo Creek averages 400 feet in width. In places, it is considerably narrower, and rarely does it exceed 500 feet in width. Buffalo Creek has a rather sinuous course as it flows southwesterly, probably because this direction of flow is approximately at a right angle to the regional dip of the bedrock. This represents the "hard way" for the creek to develop, and as a consequence, Buffalo Creek makes many swings around natural obstacles in its way. An index to the degree of sinuosity in its course is the fact that Buffalo Creek flows 17 stream miles from Saunders to Man, a straight-line distance of only 12 miles. The elevation at Saunders is about 1,500 feet; at Man it is 700 feet. Buffalo Creek drops 300 feet in the first four miles from Saunders toward Man.

C. GEOLOGY

Despite the rugged terrain of the surrounding hills, the regional geology of the area is quite simple. The site is underlain by the sandstones, shales, and coal seams of the Kanawha Series (Figures III-3A, B, and C), described by Hennan and others (1914)*; the beds dip to the

* References are listed alphabetically by author in Chapter IX.

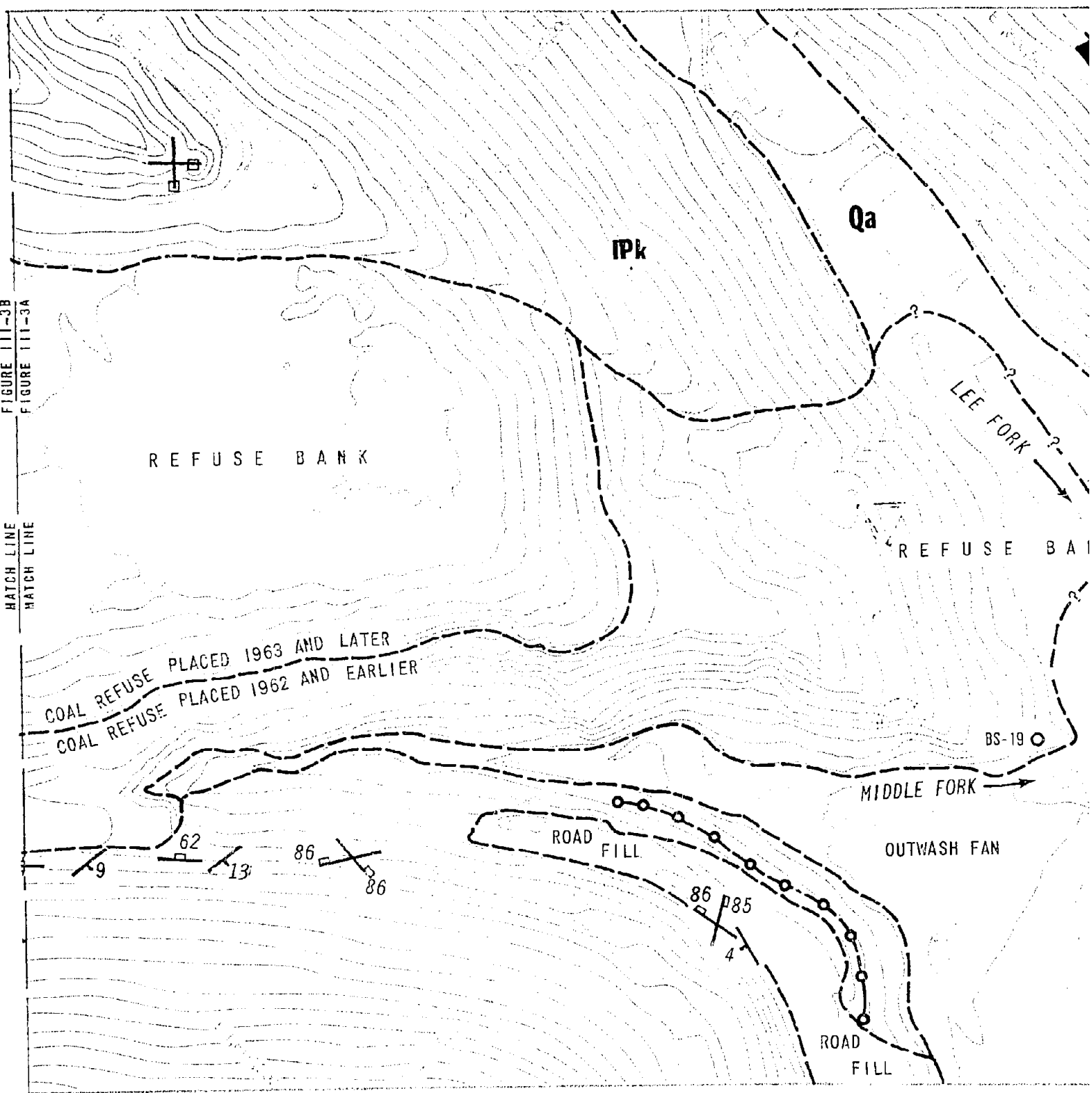

- NOTES: (1) GEOLOGIC MAPPING BASED ON TOPOGRAPHY AS OF APRIL 9, 1972. (5) FOR PRE-FAILURE TOPOGRAFI
- (2) SELECTED EXPLORATION FEATURES ONLY ARE SHOWN. FOR DETAILED GEOLOGY AND EXPLORATION OF DAM NO. 1 TO DAM NO. 3 AREA SEE FIGURE VI-20. (4) FIELD DENSITY, CONE PENI TESTS ARE SHOWN ONLY ON FIGURE VI-20.

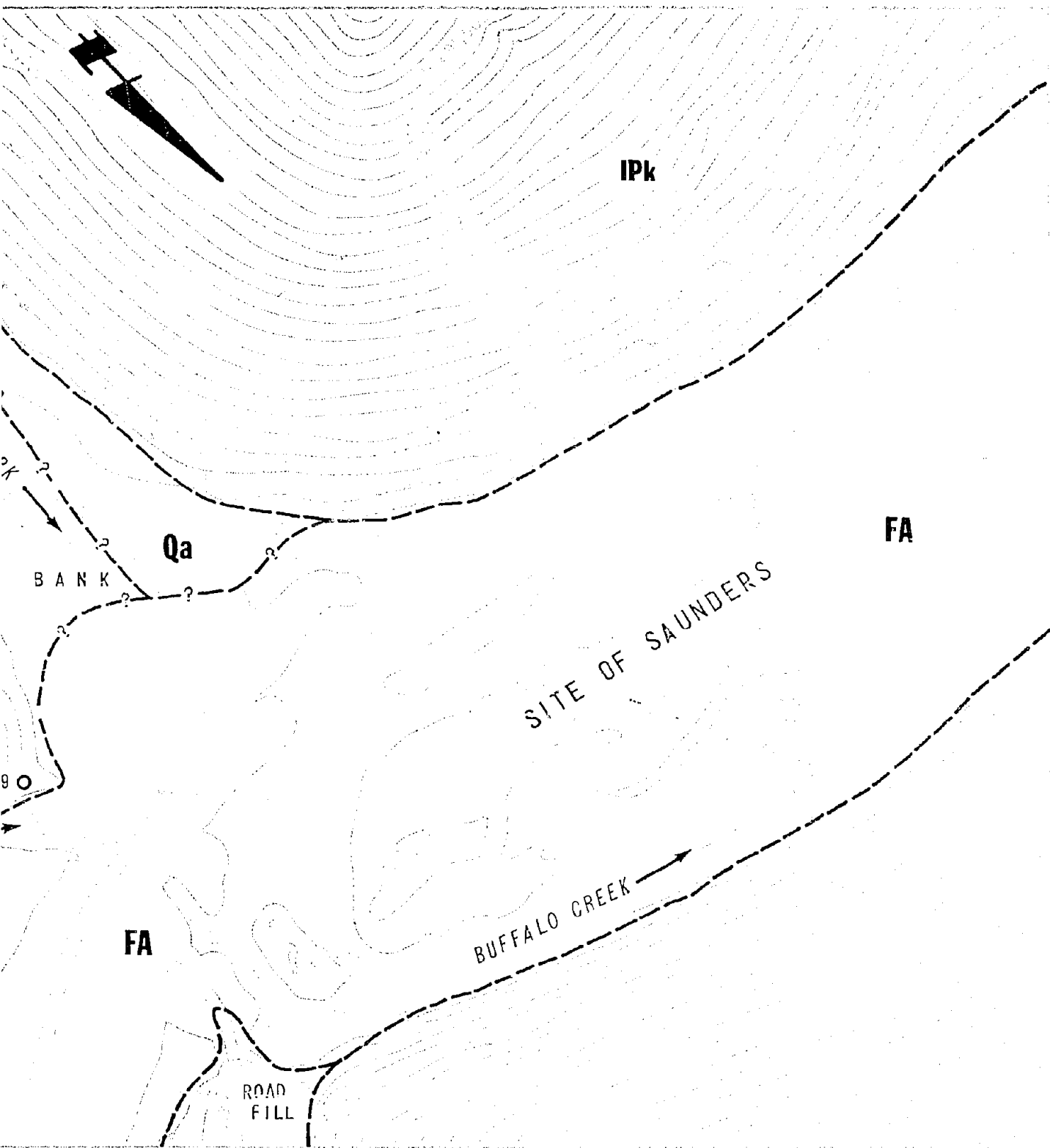

TOPOGRAPHY SEE FIGURE V-16.

CONE PENETROMETER, AND VANE SHEAR
ONLY ON AREAS NOT COVERED BY

BASE MAP BY MICHAEL BAKER, JR., INC.,
COMPILED FROM AERIAL PHOTOS FLOWN ON
4/9/72.

EXPLANATION

GEOLOGIC UNITS

HISTORICAL (1947 AND LATER)	FA	FLOOD ALLUVIUM (THIN VENEERS IN CHANNEL SECTION OF DAM NO. 3 NOT SHOWN)
	SA	STREAM ALLUVIUM
	S-1, 2, 3	SLUDGE OF POOLS 1, 2, AND 3, RESPECTIVELY
	D-1, 2, 3	REMNANTS OF DAMS 1, 2, AND 3, RESPECTIVELY
	REFUSE BANK	REFUSE BANK, FORMS PORTIONS OF DAMS 1 AND 2 (MINOR REFUSE BANKS ALSO SHOWN)
	ROAD FILL	ROAD FILL (SHOWN ONLY NEAR BUFFALO CREEK); FILL (ARTIFICIAL VALLEY FILL, VICINITY OF NO. 5 MINE)
QUATERNARY	FILL	
	COAL WASTE	LOCAL DUMPED COAL WASTE
PALEO-ZOIC	Qa	QUATERNARY STREAM ALLUVIUM (LOCALLY COVERED BY SLOPEWASH)
	Pk	KANAWHA SERIES, SHOWING COAL SEAM (SEE TEXT)

STRUCTURAL UNITS

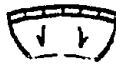
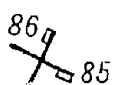
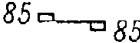
- - - ?	CONTACT BETWEEN UNITS, APPROXIMATELY LOCATED, QUESTIONED WHERE DOUBTFUL OR SPECULATIVE
	LANDSLIDE, ARROWS INDICATE DIRECTION OF MOVEMENT, HEADWALL SCARP INDICATED BY HATCHURED AREA
T-5	STREAM TERRACE IN AREA FROM DAM NO. 2 BREACH TO UPSTREAM TOE OF DAM NO. 3, TERRACE T-1 LOWEST, T-5 HIGHEST.
/ 6	STRIKE AND DIP OF BEDDING
⊕	HORIZONTAL BEDDING
/ 86	STRIKE AND DIP OF JOINT
	INTERSECTING JOINTS
	STRIKE OF VERTICAL JOINTS

EXPLORATION SYMBOLS

FIGURES III-3A AND B		FIGURES III-3B AND C	
● S-19	SAMPLED DRILL HOLE	□ BC-3	CONE PENETRATOR (P) AND OR VANE SHEAR (V)
○ BS-19	UNSAMPLED DRILL HOLE	PV-2	FIELD TEST BC-4 = PENETRATOR OR VANE SHEAR TEST IN VICINITY OF DAM NO. 4, BC-3 IN VICINITY OF DAM NO. 3 OR POOL 3.
P-11	BACKHOE PIT	▲ FD-4A	FIELD DENSITY TEST

W. A. WAHLER & ASSOCIATES	COAL REFUSE DAM FAILURE SAUNDERS, WEST VIRGINIA	GENERALIZED GEOLOGIC AND MIDDLE FORK	
	PALO ALTO • NEWPORT BEACH • CALIF.	PROJECT NO. U700	DATE NOVEMBER 1

EXPLANATION

GEOLOGIC UNITS

- FLOOD ALLUVIUM (THIN VENEERS IN CHANNEL SECTION OF DAM NO. 3 NOT SHOWN)
- STREAM ALLUVIUM
- SLUDGE OF POOLS 1, 2, AND 3, RESPECTIVELY
- REMNANTS OF DAMS 1, 2, AND 3, RESPECTIVELY
- REFUSE BANK, FORMS PORTIONS OF DAMS 1 AND 2 (MINOR REFUSE BANKS ALSO SHOWN)
- ROAD FILL (SHOWN ONLY NEAR BUFFALO CREEK); FILL (ARTIFICIAL VALLEY FILL, VICINITY OF NO. 5 MINE)
- LOCAL DUMPED COAL WASTE
- QUATERNARY STREAM ALLUVIUM (LOCALLY COVERED BY SLOPEWASH)
- KANAWHA SERIES, SHOWING COAL SEAM (SEE TEXT)

STRUCTURAL UNITS

- CONTACT BETWEEN UNITS, APPROXIMATELY LOCATED, QUESTIONED WHERE DOUBTFUL OR SPECULATIVE
- LANDSLIDE, ARROWS INDICATE DIRECTION OF MOVEMENT, HEADWALL SCARP INDICATED BY HATCHURED AREA
- STREAM TERRACE IN AREA FROM DAM NO. 2 BREACH TO UPSTREAM TOE OF DAM NO. 3, TERRACE T-1 LOWEST, T-5 HIGHEST.
- STRIKE AND DIP OF BEDDING
- HORIZONTAL BEDDING
- STRIKE AND DIP OF JOINT

INTERSECTING JOINTS

STRIKE OF VERTICAL JOINTS

EXPLORATION SYMBOLS

FIGURES 111-3A AND B

- SAMPLED DRILL HOLE
- UNSAMPLED DRILL HOLE
- BACKHOE PIT

□ BC-3
PV-2

▲ FD-4A

FIGURES 111-3B AND C

- CONE PENETRATOR (P) AND OR VANE SHEAR (V)
- FIELD TEST BC-4 = PENETROMETER OR VANE SHEAR TEST IN VICINITY OF DAM NO. 4, BC-3 IN VICINITY OF DAM NO. 3 OR POOL 3.
- ▲ FIELD DENSITY TEST

233

W. A. WAHLER & ASSOCIATES	COAL REFUSE DAM FAILURE SAUNDERS, WEST VIRGINIA	GENERALIZED GEOLOGIC AND EXPLORATION MAP MIDDLE FORK VALLEY		
		PROJECT NO.	DATE	FIGURE NO.
	PALO ALTO • NEWPORT BEACH • CALIF.	0700	NOVEMBER, 1972	11-3A

FIGURE III-3C
FIGURE III-3B
MATCH LINE
MATCH LINE

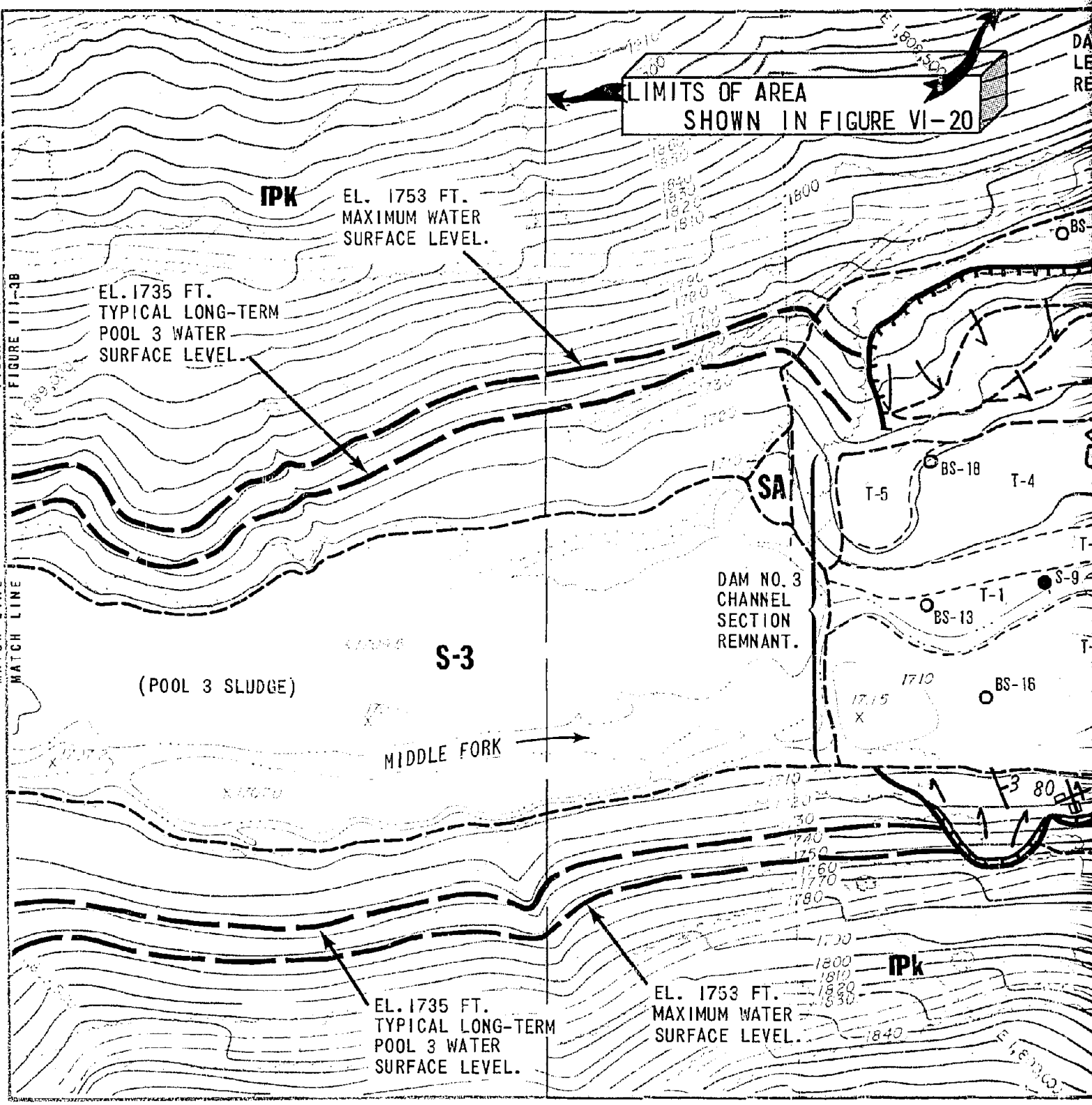

BASE MAP BY MICHAEL BAKER, JR., INC.,
COMPILED FROM AERIAL PHOTOS FLOWN ON
4/9/72.

NOTES: (1) FOR E
(2) FOR S

FIGURE VI-20

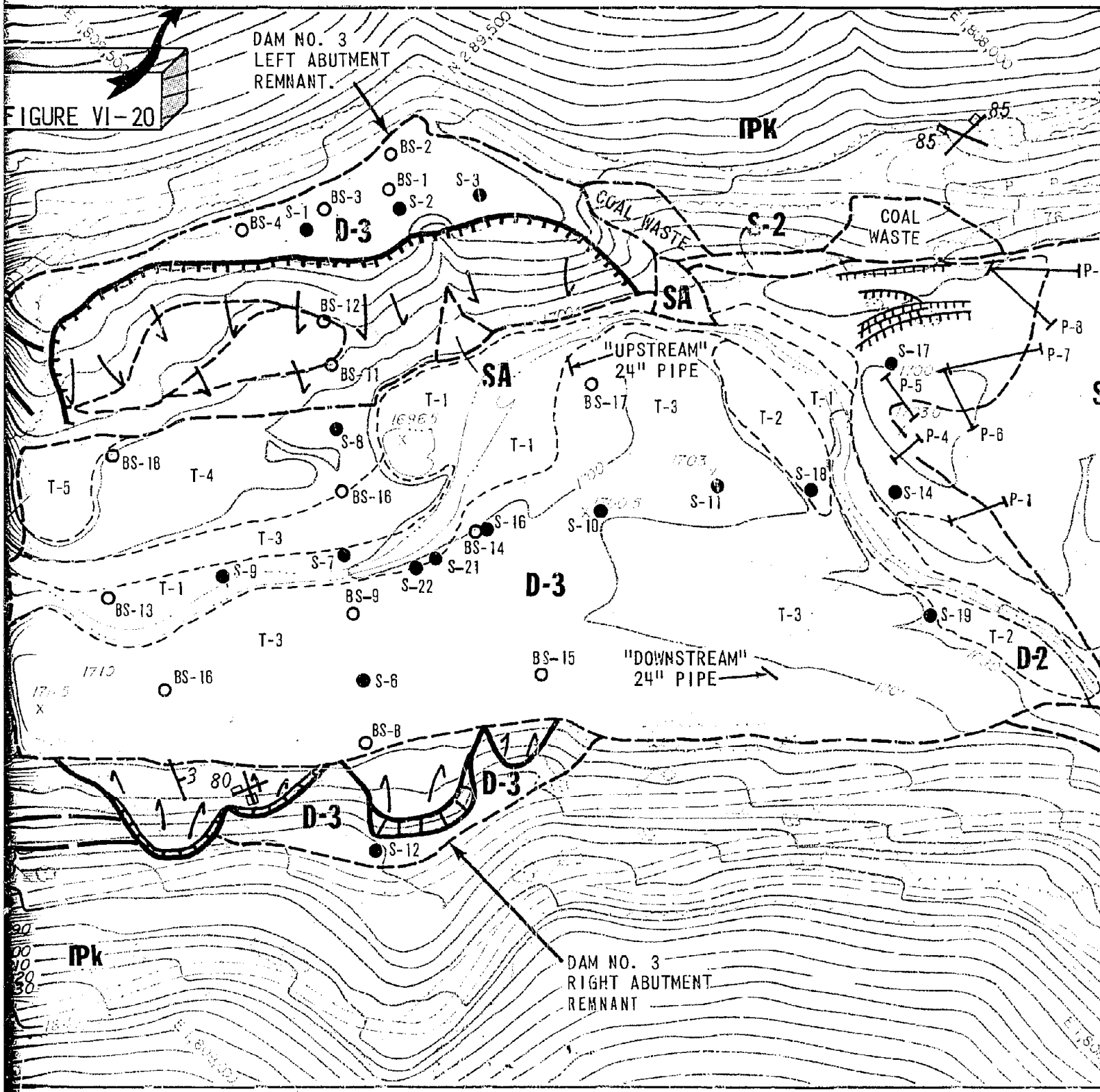

NOTES: (1) FOR EXPLANATION, SEE FIGURE III-3A.
(2) FOR DETAILED EXPLORATION MAP, SEE FIGURE VI-20.

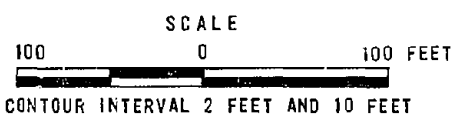
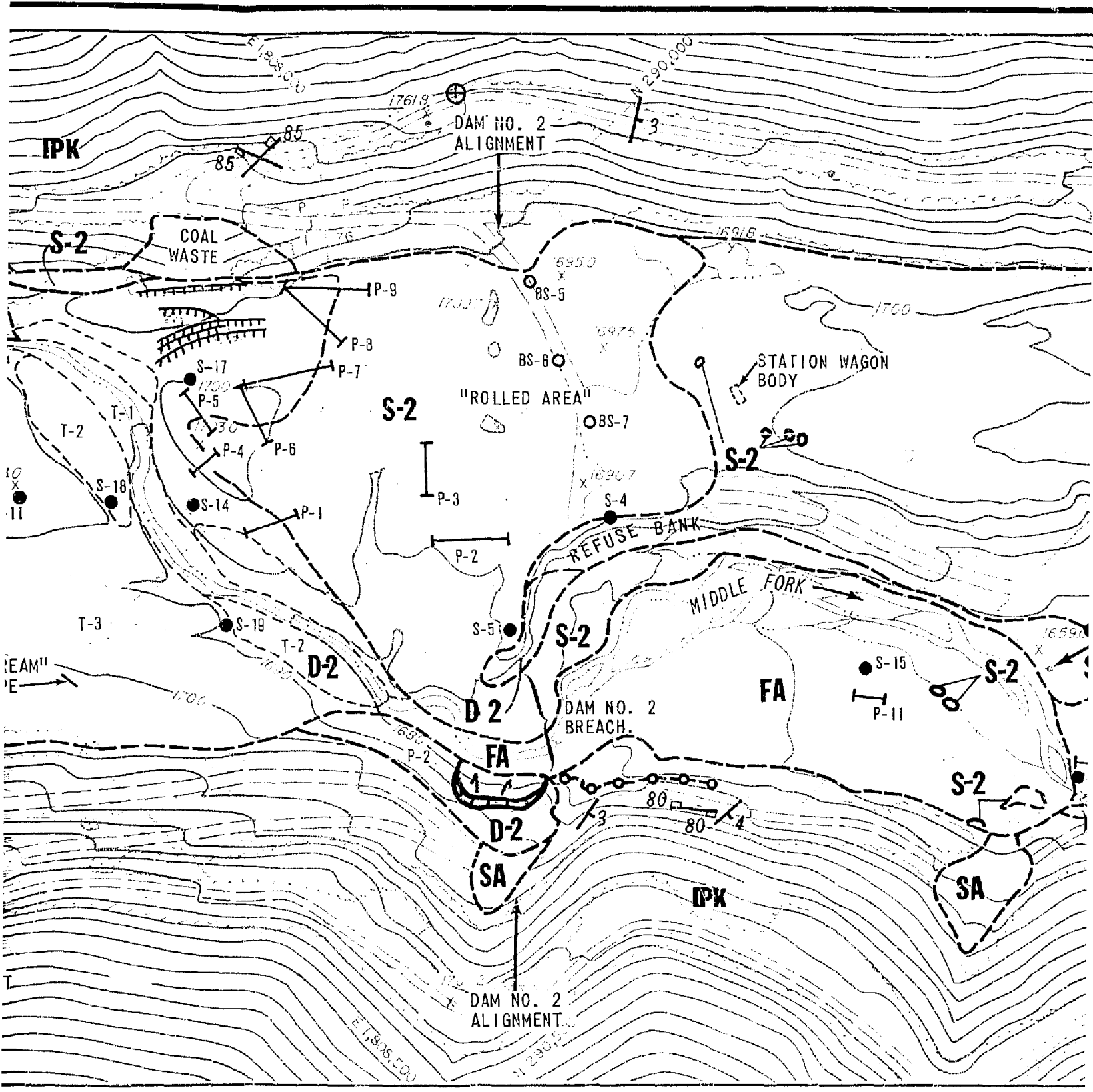

W.A
& A

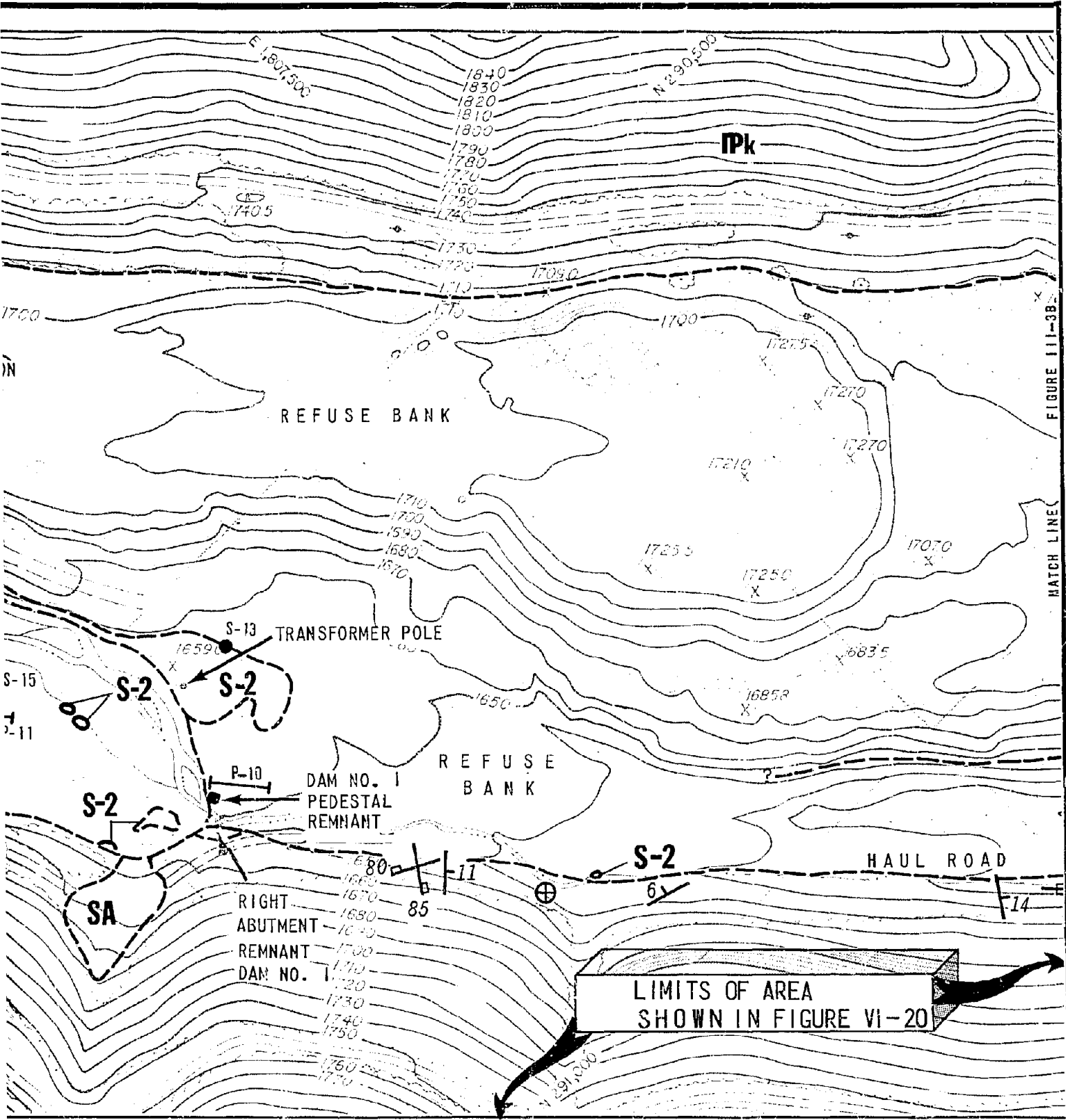
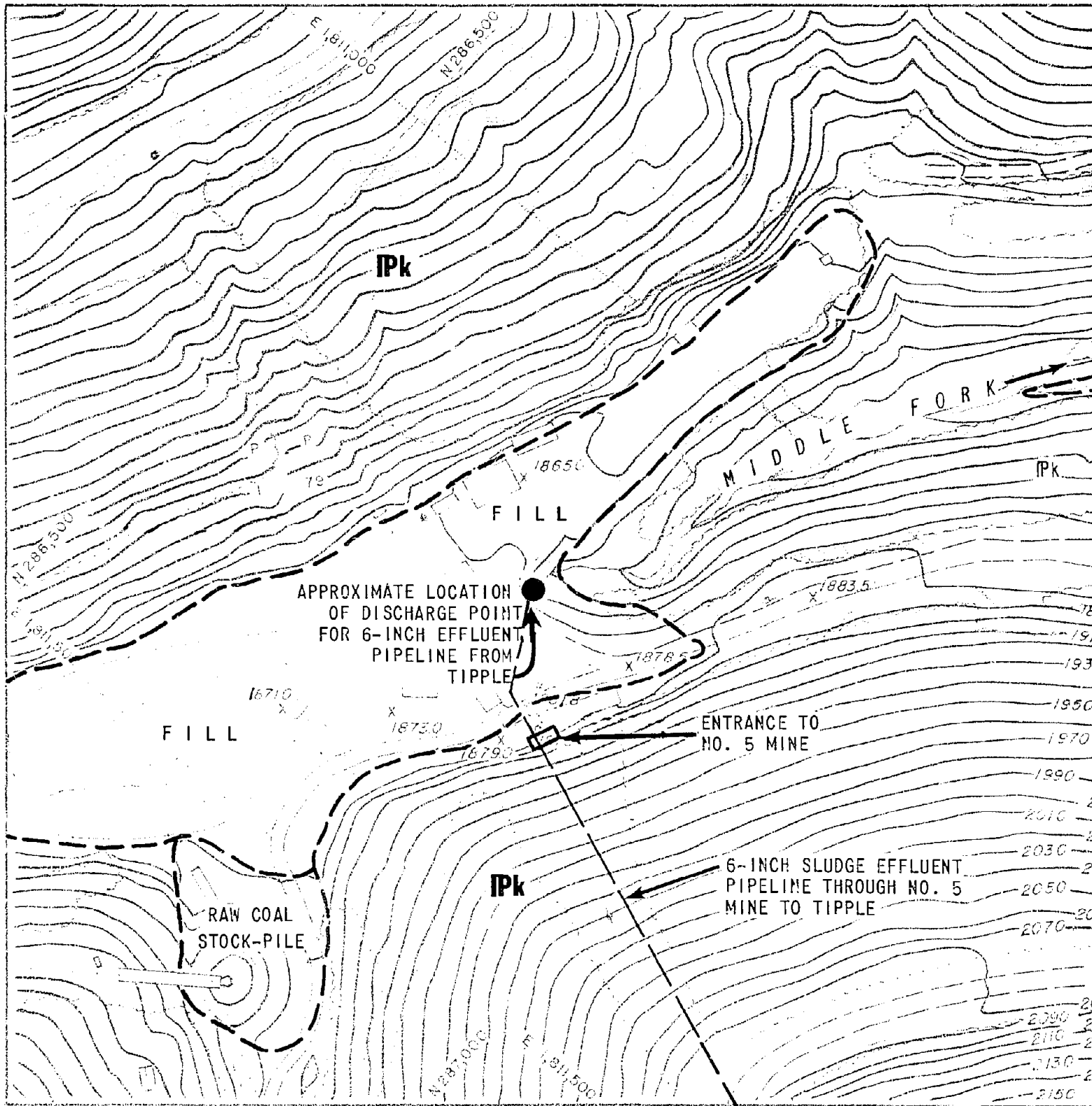
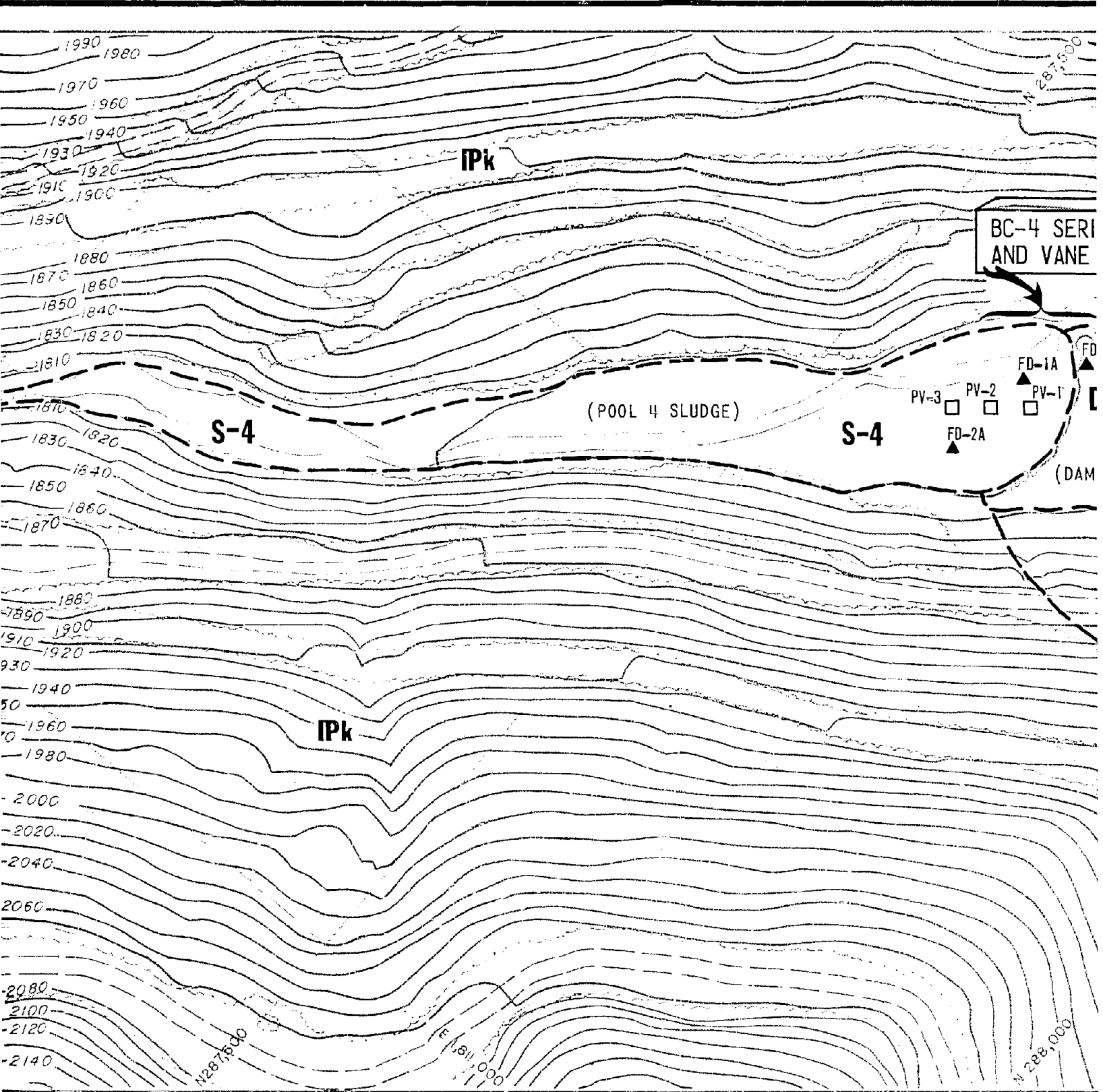

FIGURE III-38
 FIGURE III-3A
 MATCH LINE
 MATCH LINE

W. A. WAHLER & ASSOCIATES	COAL REFUSE DAM FAILURE SAUNDERS, WEST VIRGINIA		GENERALIZED GEOLOGIC AND EXPLORATION MAP MIDDLE FORK VALLEY	
	PROJECT NO	DATE	DRAWING NO	
	0700	NOVEMBER 1972	11-38	
PALO ALTO • NEWPORT BEACH • CALIF				



BASE MAP BY MICHAEL BAKER, JR., INC.,
 COMPILED FROM AERIAL PHOTOS FLOWN ON
 4/9/72.



NOTES: (1) A
 W
 (2) S
 (3)

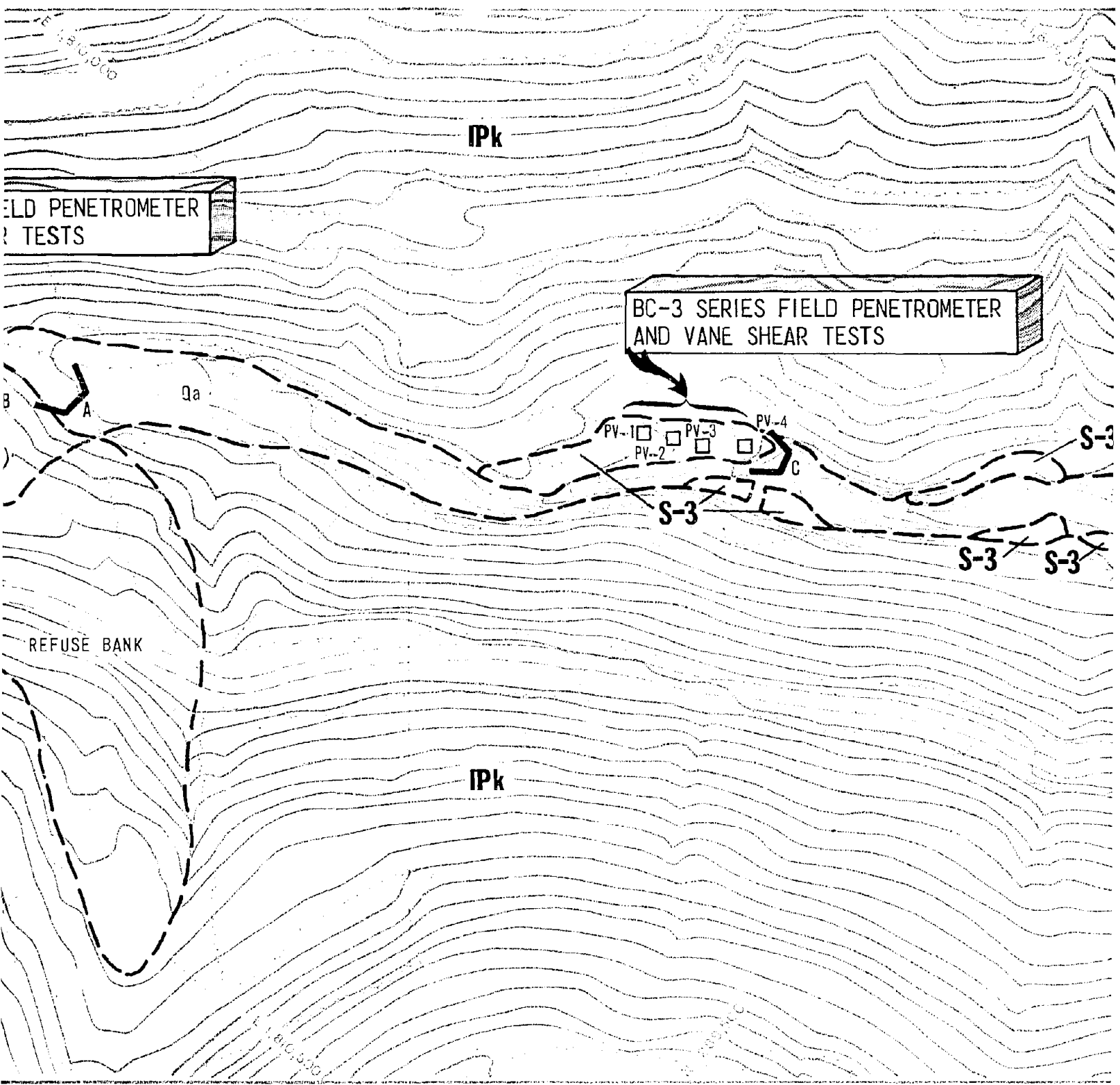

TESTS AND OTHER EXPLORATION FEATURES
 THE AREA OF THIS MAP ARE SHOWN.
 RE 111-3A FDR KEY AND ADDITIONAL NOTES.
 LOCATION OF PHOTOGRAPH ON FIGURE V-15.

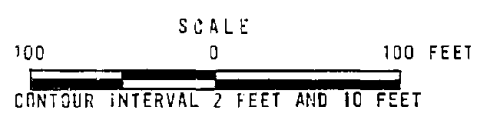

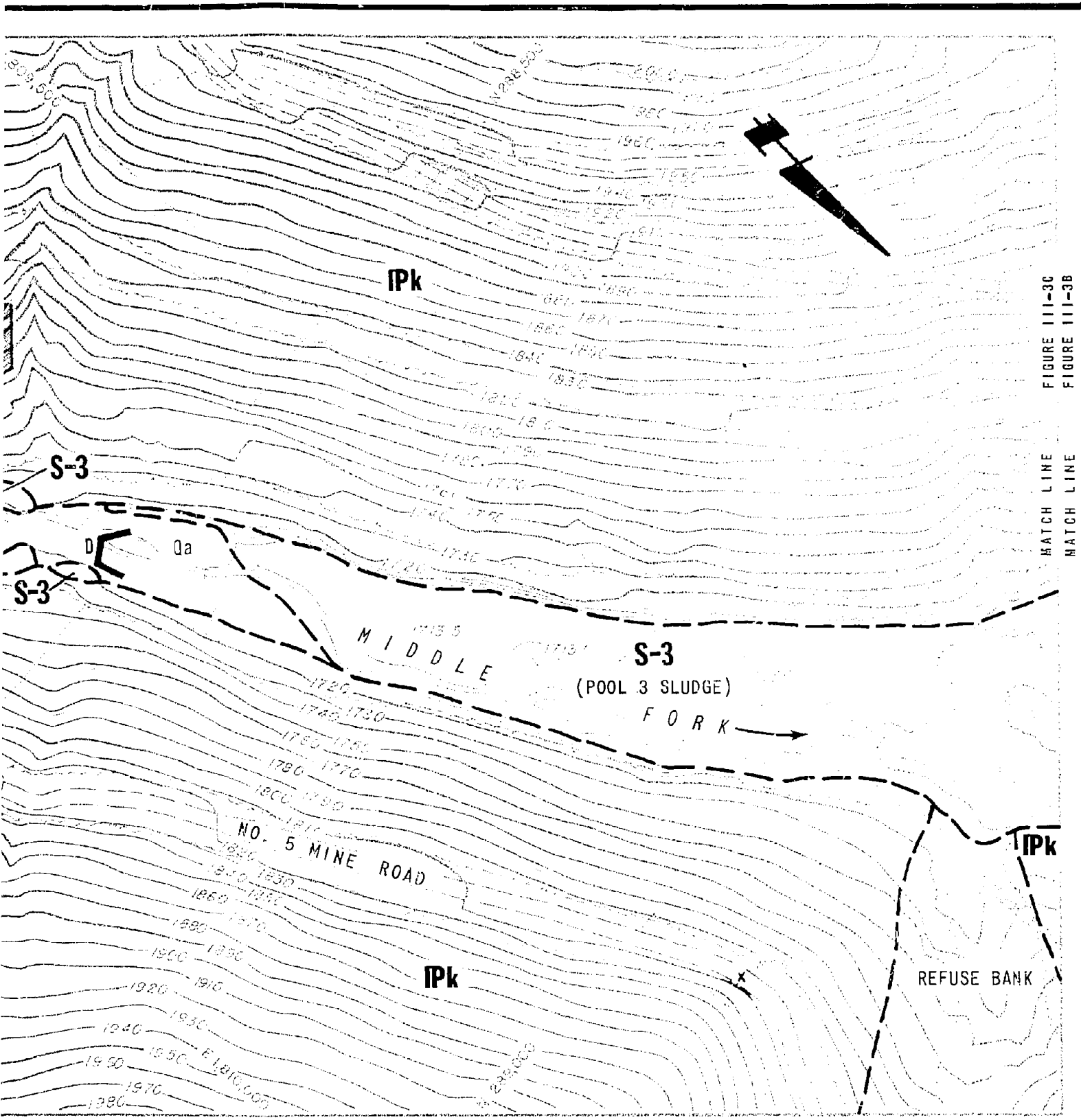

W. A. WAHLER & ASSOCIATES	COAL REFUSE DAM FAILURE SAUNDERS, WEST VIRGINIA	GENERALIZED GEOLOGIC AND EXPLORATION MAP MIDDLE FORK VALLEY		
		PROJECT NO	DATE	FIGURE NO
		0700	NOVEMBER 1972	111-3C

PALO ALTO • NEWPORT BEACH • CALIF.

northwest at 50 to 150 feet per mile. Although local flexures can be found with somewhat higher dips, for all practical purposes the bedrock strata can be considered nearly horizontal in the Middle Fork area. Most of the measured bedrock dips recorded on the geologic maps are considerably steeper than 150 feet per mile (or about $1^{\circ}38'$). The steeper dips represent measurements on cross bedding or small local flexures. Scattered minor faults can be observed in highway cuts throughout the area. Displacement usually amounts to a few feet vertically; rarely does it exceed 20 to 30 feet. Joints in the bedrock are steeply dipping to vertical, and strike about $N45^{\circ}W$ and $N35^{\circ}E$; other minor and random orientations are also present. Middle Fork hollow has developed along the major $N45^{\circ}W$ fracture system.

These rocks were deposited in shallow seas and swamps during the Pennsylvanian Period. The rhythmic sequence of non-marine sandstone, shale, and coal followed by marine shale (or occasionally limestone) is repeated throughout the rock series. These cyclothems reflect the recurrent transgression and regression of shallow inland seas.

In the Middle Fork area, sandstone is the dominant rock type in the Kanawha Series. It is generally well indurated, fine-to medium-grained, arkosic, well sorted, sub rounded, and micaceous. The light gray beds weather to a buff color. They are thick, massive, and exhibit local cross-bedding. The silty shale interbeds are light to dark gray, thinly laminated, often carbonaceous, and fossiliferous. Coal seams are generally less than 4 feet thick, but the shale and sandstone units are up to 50 feet thick. Coal seams which crop out in the map area have been tentatively identified as the Lower Chilton coal at about Elevation 1,770 above the right abutment of Dam No. 3, and the Little Chilton at about Elevation 1,678 downstream of the right abutment of Dam No. 2 (Figure III-3B). The major units tend to be continuous over distances of thousands of feet, or even many miles. The local stratigraphic column at Dam No. 3 is shown on Figure III-4. Typical outcrops

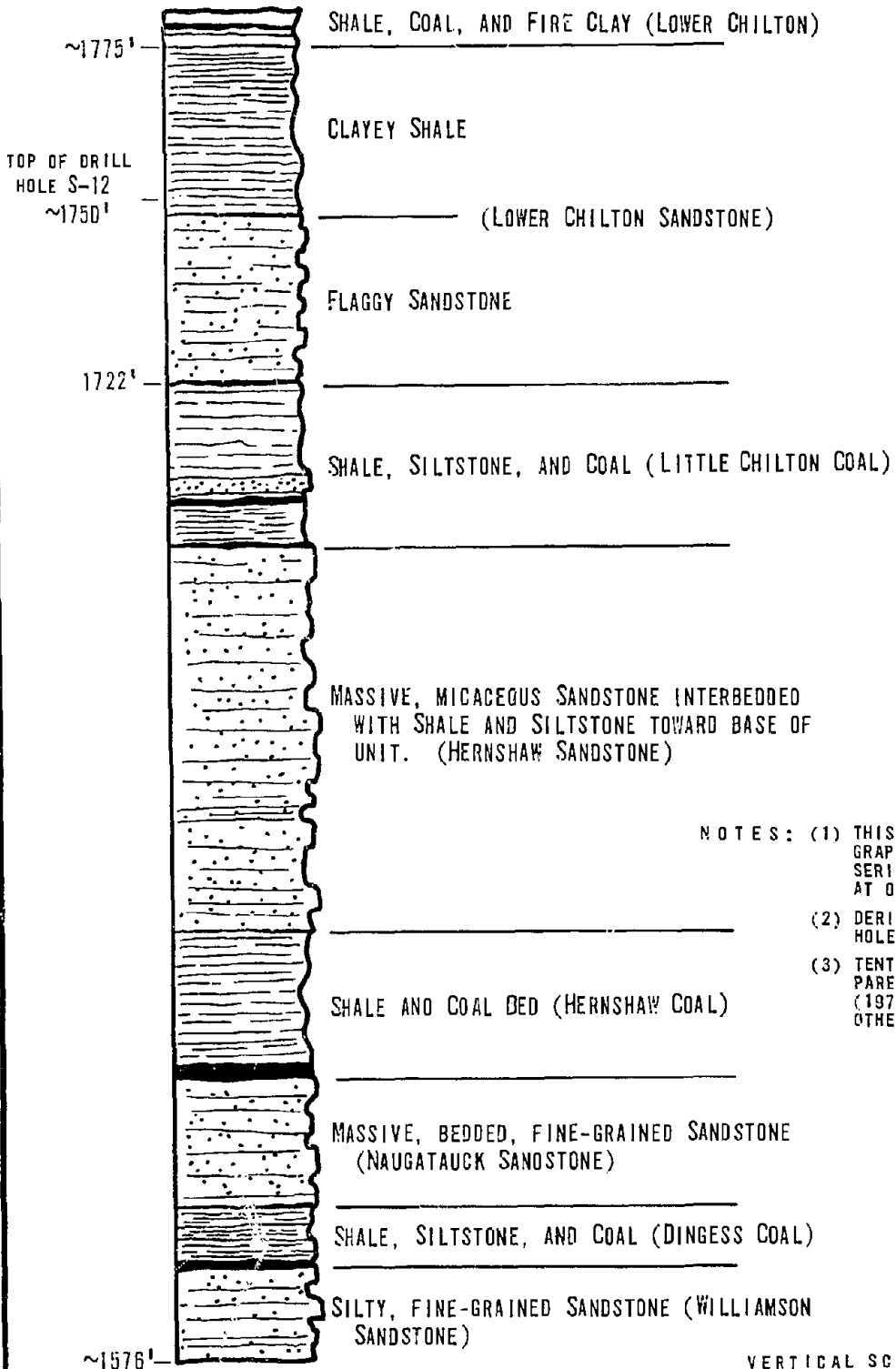

- NOTES: (1) THIS IS A PARTIAL STRATIGRAPHIC COLUMN OF THE KANAWHA SERIES (PENNSYLVANIAN PERIOD) AT DAM NO. 3 ON MIDDLE FORK.
- (2) DERIVED FROM LOG FOR DRILL HOLE S-12 AND DAVIES (1972).
- (3) TENTATIVE CORRELATIONS IN PARENTHESES FROM DAVIES (1972) AND HENNER AND OTHERS (1914).



W. A. WAHLER & ASSOCIATES	COAL REFUSE DAM FAILURE SAUNDERS, WEST VIRGINIA	STRATIGRAPHIC COLUMN AT DAM NO. 3		
		PROJECT NO. 0700	DATE NOVEMBER 1972	FIGURE NO. 111-4

PALO ALTO • NEWPORT BEACH • CALIF.

of sandstone and shale are shown on Figure III-5. (The locations of all photographs in this report are shown on Figure A-1 in Appendix A).

Soil cover is generally quite thin throughout the area. Latimer (1915) in his 1914 soil survey of Logan County, gives detailed descriptions of regional soil types and their general topographic distributions. The soil cover beneath and around Dams 1, 2, 3 and 4 in Middle Fork Valley is less than 3 to 5 feet thick and fits Latimer's Dekalb stoney silt loam classification. This soil is a yellowish to grayish-brown, friable silt loam which grades into a silty clay loam with depth. Variable amounts of sand and rock fragments are always present depending on adjacent bedrock and slope conditions.

D. HYDROLOGY

The major stream in the area is the Guyandotte River, which flows northwesterly past Man and Logan. It discharges into the Ohio River near Huntington. Within Logan County, Buffalo Creek, with a drainage area of nearly 45 square miles, is one of the larger tributaries to the Guyandotte. Middle Fork enters Buffalo Creek at the former site of Saunders, about 12 miles (straight line) and 17 stream miles upstream from the confluence of Buffalo Creek and the Guyandotte at Man. The total drainage area of Middle Fork is 745 acres; the area above Dam No. 3 is 654 acres.

Confined between steep valley walls, the narrow (400-foot wide) flood plain of Buffalo Creek offers little opportunity to build structures above the level of the 50-year flood. The West Virginia Ad Hoc Commission Report* describes factors contributing to flood susceptibility as follows:

*The report of the West Virginia Ad Hoc Commission of Inquiry into the Buffalo Creek Flood, entitled "The Buffalo Creek Flood and Disaster," is referred to hereafter as the "Commission Report" for convenience.



PHOTO A. SANDSTONE NEAR THE LEFT ABUTMENT OF DAM NO. 3. HEIGHT OF OUTCROP IS ABOUT 12 FEET.



PHOTO B. SHALE ALONG NO. 5 MINE ROAD ABOVE POOL 2. THE FOLDING RULE LIES ON A BEDDING PLANE. LEFT OF THE RULE IS AN AREA OF VERY CLOSELY SPACED NEAR-VERTICAL JOINTS.

The steepness of the valley walls and the thinness of the soil cover contribute to the flood flows in Buffalo Creek Valley, and these same conditions persist in virtually all other hollows or valleys south of the Kanawha River. Instead of thick soils that could absorb some of the precipitation runoff, soils on the uplands and valley walls in this entire region are thin, generally less than 3 feet thick and seldom as much as 5 feet thick. Additionally, soils in the region tend to a composition of low permeability and are dominantly a clay-like, silty sand with large quantities of stone varying from small chips to boulders a foot or so long. They are commonly underlain by clay layers up to an inch thick between the base of the soil zone and the underlying bedrock.

Thus, all of these factors--the tortuosity of the channel, the narrowness of the flood plain, the steepness and height of the valley's walls, and the thinness and relative impermeability of the soil--combine to make Buffalo Creek a hollow susceptible to damage from flooding . . .

Strip mines in the valley also tend to increase runoff by removing vegetation and soil; however, the quantitative influence on runoff is difficult to determine precisely.

CHAPTER IV

MINE AND PLANT DESCRIPTION AND OPERATION

A. GENERAL

Coal mining operations in the United States can be classified according to three general operating categories: deep mines, strip mines, and auger mines. In a deep mine, the mining phase does not intentionally disturb the original ground surface. The terms deep, underground, and drift are generally used interchangeably. An area strip mine requires that the surface overburden be removed in order to expose the coal seam. In addition, area stripping involves placing the soil and rock overburden from each successive cut into the previous mining cut after the coal has been removed, and generally covers large areas of relatively flat land. An auger mine consists of a two-phase operation in hilly terrain in which a seam of coal is first exposed by a sidehill cut, or contour stripping, thus allowing removal of the coal by horizontal augering without further disturbance of the original ground surface.

In the Buffalo Creek area, natural erosion processes have left blocks of coal perched under hilltops and exposed on at least one edge. Some of these remnant blocks contain relatively small tonnages, and cannot economically support the capital investment required to initiate and sustain an underground mining operation. However, their location makes them amenable to auger mining, since the contour stripping required to expose the coal along a hillside bench involves moving rather small amounts of soil and rock. In West Virginia, the development of an auger bench is referred to as a "strip job," even though this term is ordinarily used elsewhere to denote area stripping operations. With larger blocks of coal, the material on the hillside perimeter may be removed by the economical auger method up to the maximum horizontal distance

possible, and the remaining coal mined by underground methods. The contour strip cut, since much of the original ground material has been displaced downward, is usually not fully restored. Rather, the exposed coal face is covered, and the auger bench graded and seeded.

B. BUFFALO MINING COMPANY

The original mining activity by the Lorado Coal Mining Company in the Middle Fork area began in 1945 with the opening of the No. 5 mine. In 1947, the No. 5 coal preparation plant, located on Buffalo Creek about one-half mile above the Middle Fork confluence, was placed in operation and the first coal waste was dumped near the mouth of the Middle Fork Valley. The initial dumping rate was 800 to 1,000 tons per day, and dumping continued at about this same rate, except for periods when the mines were shut down, for the next 25 years.

In November 1963, the Lorado Coal Mining Company ceased operations at both the No. 5 mine and the No. 5 coal preparation plant. The operations remained inactive until October 1964 when the Buffalo Mining Company resumed operation of the mine and preparation plant. In June 1970, the Pittston Company acquired the Buffalo Mining Company properties, and continues to control the operations at the present time.

The total feed of 5,000 tons per day to the No. 5 coal preparation plant was mined by the Buffalo Mining Company from its own mines in the vicinity of Middle Fork Valley.

In February of 1972, Buffalo Mining Company had developed eight mines in the area: five underground mines, two auger mines, and a "strip" mine. The underground equipment consisted of Joy loaders and shuttle cars for the operation of the room-and-pillar drift mines. Details for each of the mines are given in Table IV-1.

TABLE IV-1
 BUFFALO MINING COMPANY
No. 5 COAL PLANT OPERATIONS

<u>Mine Name</u>	<u>Potential Production Tons Per Day</u>	<u>Employees</u>	<u>Coal Seam</u>	
			<u>Common Name</u>	<u>Height (inches)</u>
No. 5	580	40	Chilton	42
No. 5A	1500	90	Chilton	46
No. 8B	1500	91	Chilton	60
No. 8C	800	38	Chilton	96
No. 8½	250	14	Dorothy	38
Strip Job	500	26	Stockton	28
No. 1 Auger	200	3	Stockton	28
No. 2 Auger	500	4	Stockton	28

C. NO. 5 MINE COAL PREPARATION PLANT

In February 1972, the No. 5 mine coal preparation plant was operating two shifts per day, five and six days per week to process the entire daily mine production of the Buffalo Mining Company, a total of 4,500 to 5,000 tons per day.

The plant was a coal washing operation, utilizing vibratory and shaker screens, Jeffrey Baum jigs, picking tables, and CMI dryers. All of the plant feed was washed, and the following sizes were shipped on the Chesapeake and Ohio Railway:

6" x 3"	Egg
3" x 2"	Stove
2" x 1½"	Nut
1½" x ¾"	Stoker
½" x 0"	Carbon

D. OPERATION OF MINE AND COAL PLANT

1. Previous History

As noted previously, mining commenced in the Middle Fork area in 1945. Initial attempts to reduce the amount of coal waste material being discharged into Buffalo Creek began in 1954 when the Lorado Mining Company, at the request of the West Virginia Water Resources Commission, undertook a study of the problem. In July 1955, drawings of the disposal facilities were submitted to the Commission, and a six-month permit (No. 65) was issued on August 19, 1955. This permit was made permanent on June 28, 1956.

A letter to the Water Resources Commission in January 1958 indicated an attempt would be made to close the water circuit and that froth flotation would be used for fine coal recovery. Inspections by the Water Resources Commission in August, October and December 1958 showed coal waste still being discharged into Buffalo Creek. A December 16, 1958 letter to the company from the Commission elicited a reply in March 1959 that additional studies were underway. The mining company stated in a following letter on August 27, 1959 that a consulting firm had recommended a filter type installation. However, cost studies indicated that the filtering system would not be feasible for varying feed from other coal seams, and in April 1959, the mining company proposed to construct a series of dams behind the then existing solid waste pile at the mouth of the Middle Fork Valley to be used as settling basins for the "black" plant water. The construction of the first dam began in May 1960.

Approximately 7,400 feet of six-inch pipe were laid through underground openings in the No. 5 Mine to carry the plant water to the Middle Fork Valley, where the slurry was discharged into the Middle Fork drainage above the coal waste disposal area.

When the USGS surveyed the Middle Fork disposal site in 1967, at the request of the USBM after the Aberfan, Wales coal waste dump failure, they reported that initial attempts to create a reservoir had failed since the water drained through the coal waste bank too rapidly. However, after strip and auger operations introduced fine (clay) material into the waste, the bank became less pervious and an impoundment resulted. At this time, between 400 and 500 thousand gallons per day containing some 500 tons of solids were being pumped to the impoundment each working day.

2. 1972 Operations

In 1972, the plant water consumption, as indicated on Figure IV-1, was still estimated at 500,000 gallons per day to process 5,000 tons per day of raw coal. Pumping to the settling pond behind No. 3 dam was at the rate of 500 gallons per minute for 10 hours per working day. The plant discard to the pond contained approximately 18 percent by weight of solid material. Thus, about 200 to 225 tons of fine coal waste were discharged each day to the pond.

In February 1972, Buffalo Mining Company was operating seven of the eight mines and the No. 5 Preparation Plant. Approximately 350 men were employed in the operations which were producing 5,000 tons per day. After the February 26 embankment failure and resulting flood, operations were reduced to five mines (three underground, one strip, and one auger) and employment curtailed to approximately 310 men.

The Buffalo Mining Company started to install a new water clarification system at the No. 5 plant consisting of a spiral classifier to remove some large sizes of marketable coal fines, and a thickener to remove the coal sludge from the plant water. With this system, water and waste from the existing drag-tank will be pumped to the classifier rather than a settling pond. The solids removed here will be moved

by a screw conveyor to the CMI dryers. The thickener will allow separation of the fine sludge which can then be pumped to a small retaining basin. This basin will be excavated periodically, and the settled sludge trucked to a disposal area.

The use of settling ponds will be required only in the event of equipment malfunction, and there will probably be no need for a large impoundment.

BUFFALO MINING COMPANY MATERIAL FLOW CHART
1972 PREFAILURE

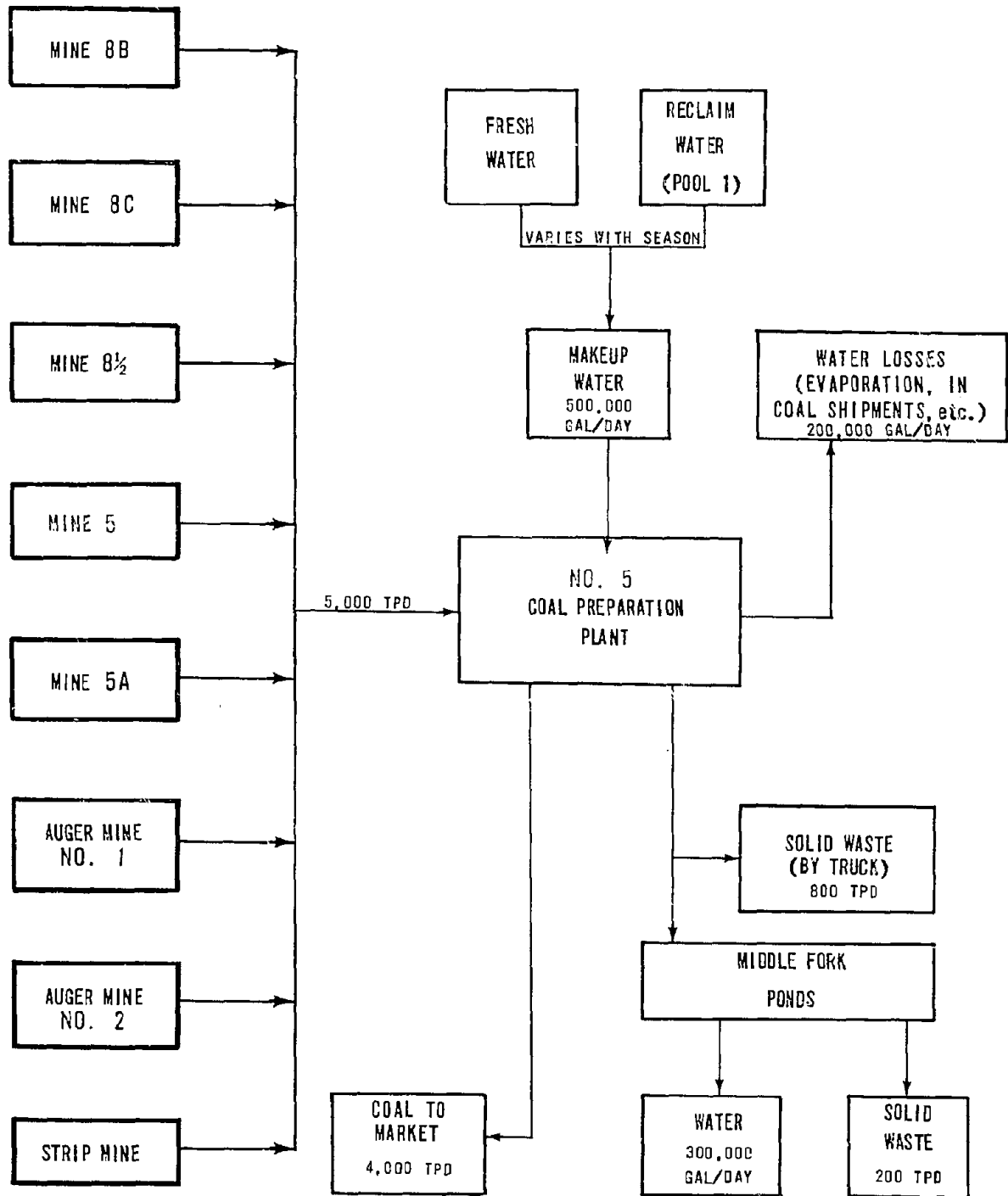

CHAPTER V

DESCRIPTION OF REFUSE DAMS

A. INTRODUCTION

This chapter traces the history of coal refuse emplacement in Middle Fork Valley. It describes the method of construction and general layout of the dams and refuse bank prior to the February 26, 1972 failure. Engineering nomenclature with respect to "right" and "left" in referring to dams and streams means right and left as perceived by a person looking downstream; that convention is used in this report. Because most of the records of the Buffalo Mining Company were destroyed by the flood, the statements made in this chapter are of necessity based on testimony, interviews, field evidence, and deductions from these sources.

Prior to the February 26, 1972 failure, there were four dams in Middle Fork Valley. They are referred to by the Buffalo Mining Company, and in this report, as Dam No. 1 through Dam No. 4, from downstream to upstream. The pools behind these dams are referred to as Pools 1 through 4, respectively. The term "dam" is used here to mean any barrier or embankment that blocks or is intended to block a watercourse and which therefore impounds water or other materials or has the potential for impounding them, whether or not the actual impoundment of water or other materials was an intended result of placing the barrier. An impoundment is a pool or reservoir formed upstream of a barrier (dam). An embankment or "bank" is a man-made mound of earth, earth materials, or coal refuse. An embankment may or may not act as a dam.

Diagrammatic sketches, executed by an illustrator in close coordination with our geologists and engineers, are used extensively here and in

Chapters VI and VII to supplement the other illustrations and the text. Some of the supportive maps and tables for this chapter have been placed in Appendix C. This will not seriously inconvenience the technically inclined reader, and the casual reader will benefit by the omission here of technical details and supportive compilations.

B. CONSTRUCTION METHODS

1. General

The construction methods used for building the refuse bank and dams have been described in several reports and in testimony. All observers are in essential agreement that the embankments were built by truck-dumping of coal processing refuse, with grading of the end-dumped piles by bulldozers to create a relatively smooth working surface. In addition to coal refuse (clayey shale, carbonaceous shale, and bony coal), the refuse banks contained small amounts of such mine refuse as wedges, crib blocks, posts, and roof bolts. We have abstracted various authors' descriptions of construction methods in Table C-1 in Appendix C.

Apparently, none of the embankments were constructed on the basis of engineered plans, and neither were they constructed on the basis of studies of the engineering properties of the coal refuse of which they were built. The dams were not constructed under any system of close supervision or control of construction procedures or materials properties. We have been unable to ascertain if topographic mapping suitable for engineering design was accomplished before the valley was filled with refuse.

The only compaction the dams received was that which resulted from truck wheel loads and bulldozer track loads. Since this compaction was not controlled by on-site supervision and testing, it varied in intensity

and effectiveness from place to place and time to time, producing dams with random amounts of compaction.

Other factors which are normally considered in earth dam design, and which appear to have not been carried into construction practice on Middle Fork, include adequate hydrology studies and the inclusion of emergency spillways based on such studies, and the importance of placing a dam on a properly prepared foundation. Several sources mention, and postfailure evidence confirms, the lack of clearing of trees, soil, and sludge from the foundation areas of Dams 2 and 3.

2. Effects on Embankment Structure

The field evidence after the failure generally confirms the reported construction methods. The Frontispiece shows the refuse bank after the flood. Piles of truck-dumped fill which have not been leveled can be seen at the downstream end of the bank. A general correlation of levels or lifts of refuse with age is shown on Figure VI-1.

The pedestal remnant of Dam No. 1 is shown on Figure V-1. In portions of the remnant, a dip of 20° to 30° can be seen, indicating layering of the refuse on a slope during construction, such as would occur if the material were dumped in piles or pushed or dumped down a slope.

The internal structure of Dam No. 2 is shown on Figures V-2 and V-3. Here, as elsewhere in the limited visible remains of Dam No. 2, the dam appears to have nearly horizontal bedding. The structure of the portions of the dam carried away by the flood is unknown, but the missing portion downstream of drill hole S-5 (see Figure V-3) may have been a repair of a previous failure that was poorly bonded to the dam.

The method of construction of Dam No. 3 has been reported on in detail by many authors (see Table C-1). Photographs of the wall of the

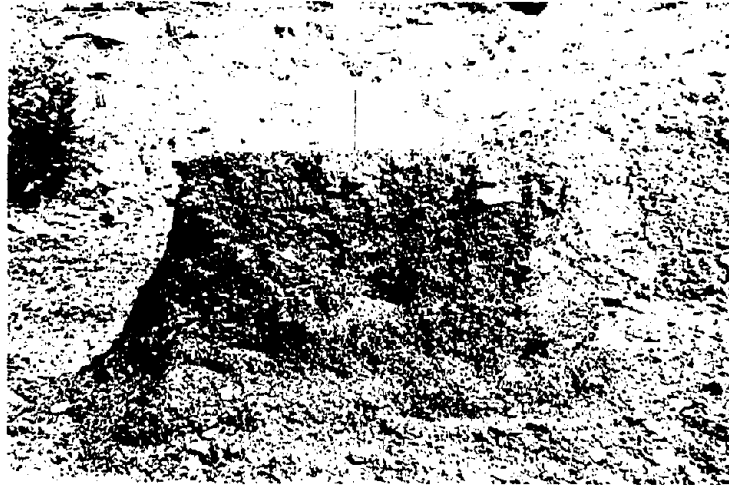
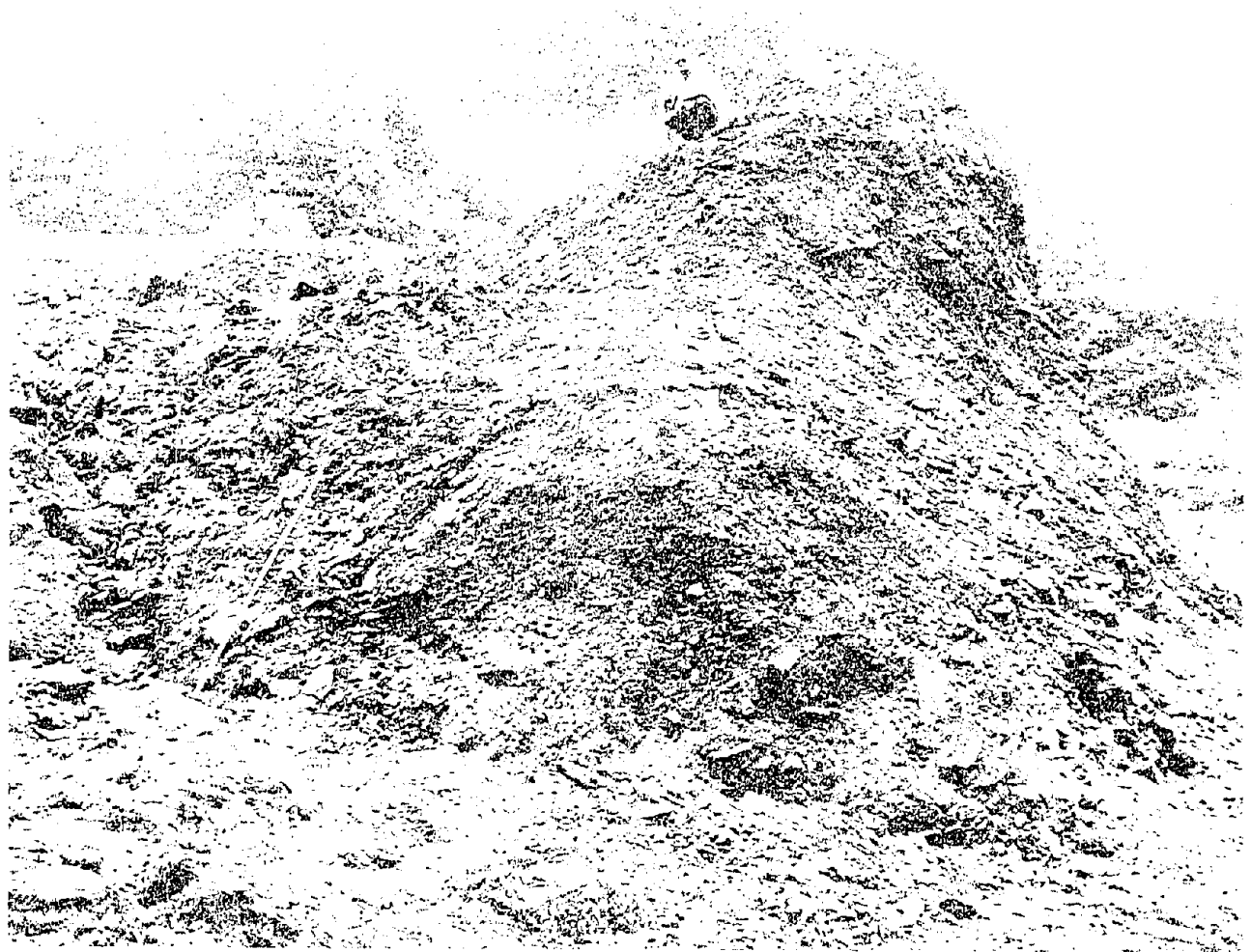

PHOTO A. DAM NO. 1 PEDESTAL REMNANT, SIDE VIEW
NOTE DIP OF GRAVEL FROM UPPER RIGHT TO LOWER
LEFT STAKE ON TOP IS TWO FEET HIGH.



PHOTO B. DAM NO. 1 PEDESTAL REMNANT,
FRONT FACE NOTE VARYING DOWNSTREAM
DIPS.



SOUTHWEST SIDE OF BREACH IN DAM NO. 1. GENERAL STRUCTURE OF DAM TO BE RELATIVELY FLAT-LAYING TO MASSIVE LAYERS. POOL 1 (SEEN IN LEFT FOREGROUND) HAS FLOWED ALONG BREACH FLOOR TOWARD POOL 2 TO THE RIGHT. CREST OF DAM IS AT LEVEL 15. MAX. D. REEF CUT IS COVERED WITH ABOUT FOUR FEET OF POOL 2 SEDIMENT. MEASUREMENTS MADE BY 15 FEET LONG

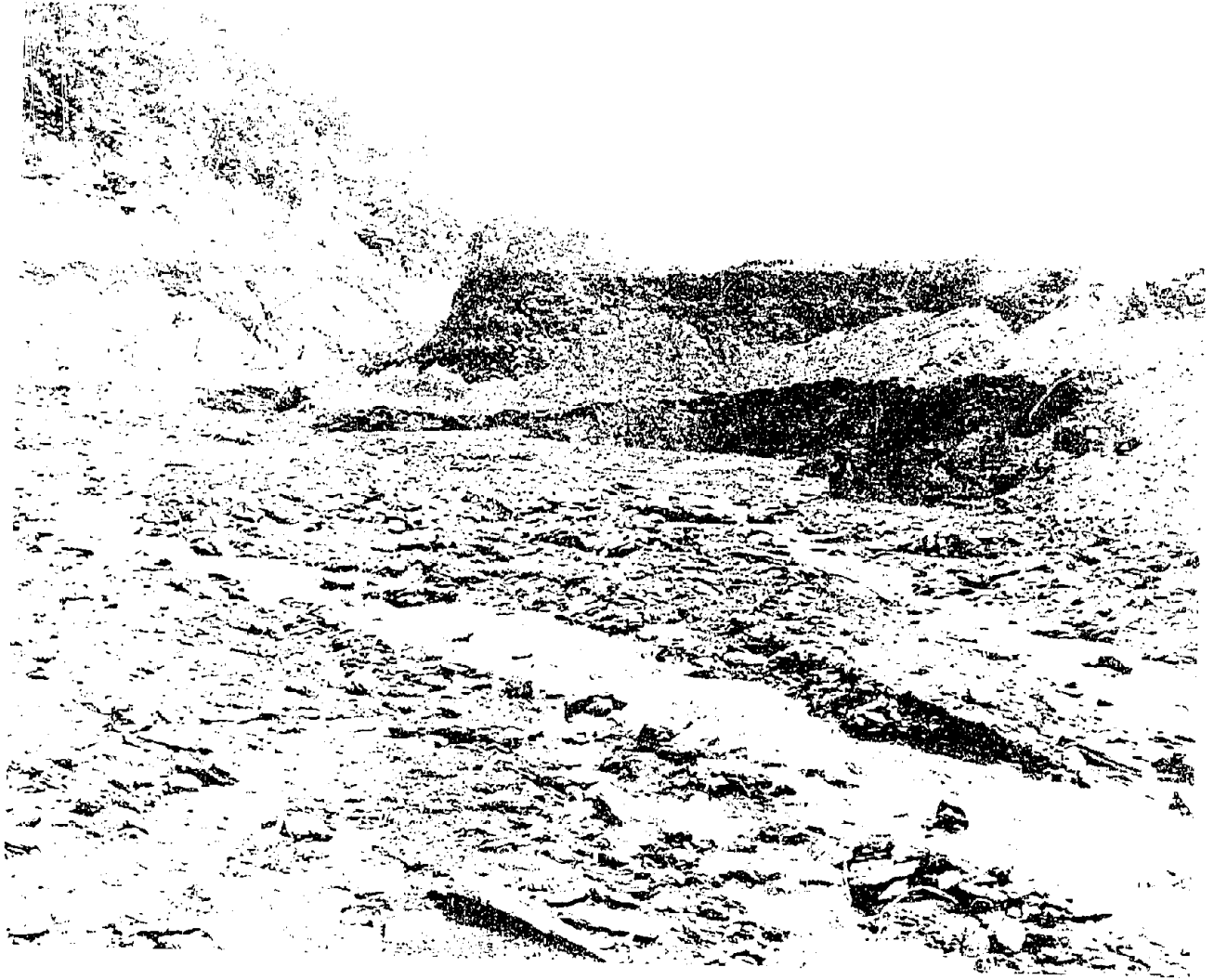

DAM NO. 2 FROM POOL 1 BREACH ON LEFT. THE EXPOSED FACE SHOWS HORIZONTAL LAYERING.
APPROXIMATE LOCATION OF HOLE S-5 INDICATED BY ARROW

bulldozer trench cut in the left abutment remnant (Figure V-4), illustrate typical "bedding" in the Dam No. 3 embankment. The method of construction led to a combination of sloping layers and subhorizontal layers, somewhat analogous to topset and foreset beds in deltas, as shown on Figure V-5. The sloping layers were formed on the advancing faces as the initial embankment grew from the right abutment toward the left. The subhorizontal layers were formed by grading equipment working on the top surface of the embankment to level dumped piles of refuse. After the dam was completed across the valley, refuse was either dumped or pushed down a face, or dumped and spread on the top of the dam. The top of the dam consisted of successive layers of leveled piles of dumped refuse four to six feet thick. Any extensive grading on the top of the dam would create wide areas of horizontally bedded refuse, as seen in the schematic cutaway diagram of Dam No. 3, Figure V-5. The faces of the dam grew by the formation of shell layers parallel to each face. Shells oriented so as to increase the probability of shallow sliding can also be seen. In addition, this method of placement would naturally tend to cause segregation of the coarser rock sizes toward the bottom of the fill. Thus, the embankment was not homogeneous or structureless in detail. The significance of these features with respect to our engineering analyses is discussed in Chapter VII.

C. CONSTRUCTION HISTORY

1. Prior to Start of Dam No. 3 (1947-1968)

There are few precise records or maps that illustrate the growth history of the refuse bank and dams. The 1914 edition of the Bald Knob Quadrangle (all maps referred to herein as quadrangle maps are published by the U.S. Geological Survey) at a scale of 1:62,500 is the earliest available map we examined. It shows Middle Fork (identified

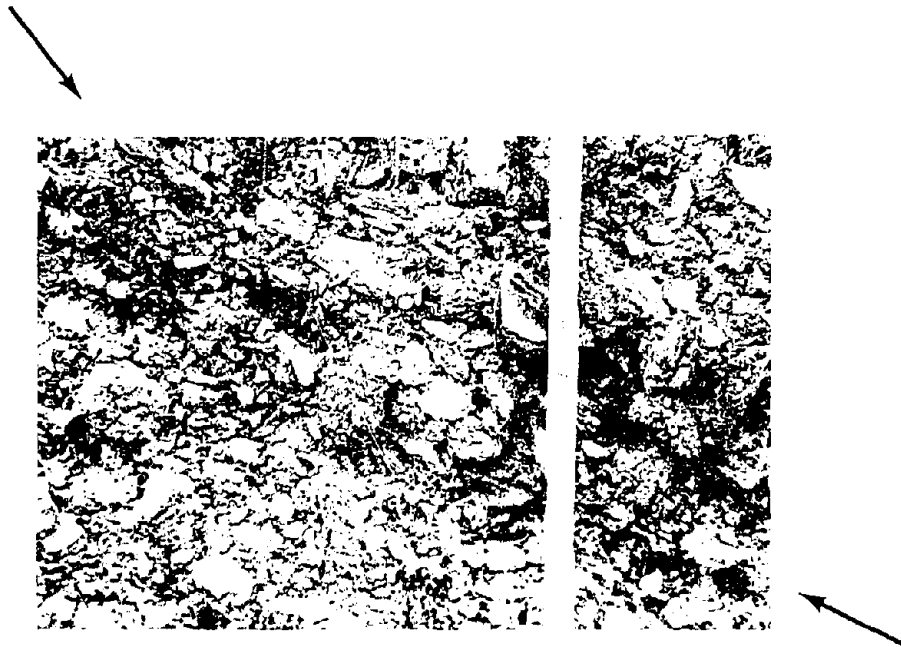

PHOTO A. DETAIL OF BULLDOZER TRENCH WALL IN LEFT ABUTMENT REMNANT OF DAM NO. 3. RAIN HAS WASHED THE SAND FROM THE WALL, LEAVING THE GRAVEL EXPOSED. NOTE LOCAL TENDENCY FOR DIPPING DOWN-STREAM, INDICATED BY ARROWS. GRADUATIONS ON STICK ARE TENTHS OF FEET

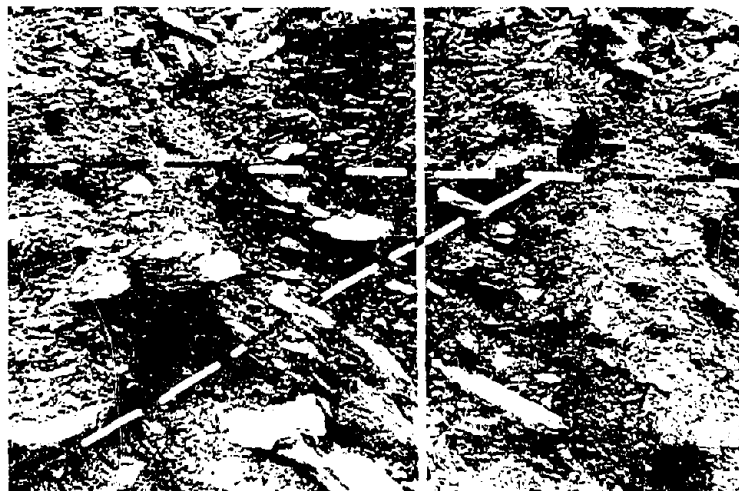
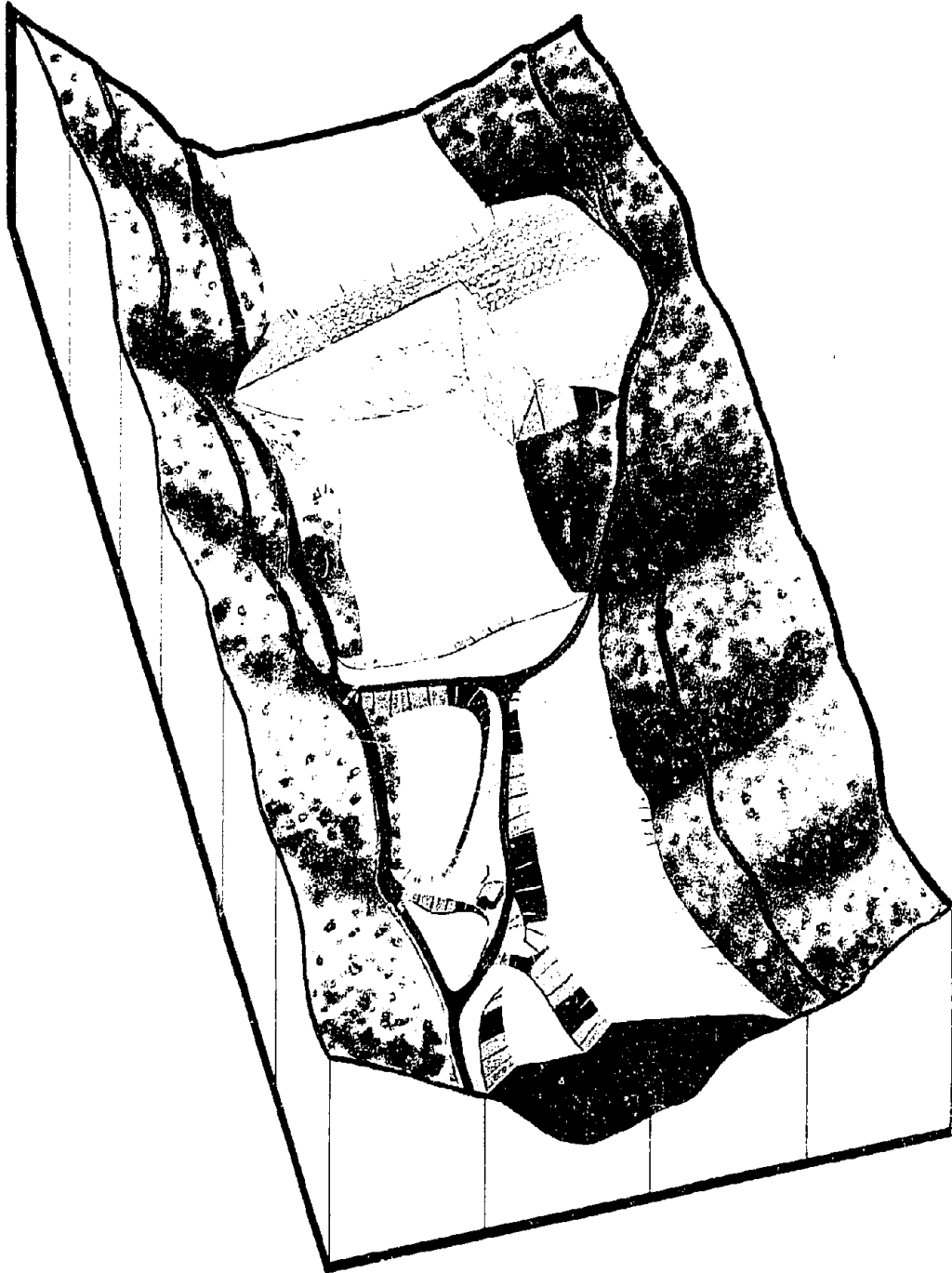

PHOTO B. DETAIL OF BULLDOZER TRENCH WALL IN LEFT ABUTMENT REMNANT OF DAM NO. 3. LINES ARE CONTACTS BETWEEN LAYERS OF FILL. THE TOP LAYER IS HORIZONTAL. THE LOWER ONES DIP MODERATELY TO THE RIGHT AND SHALLOWLY TO THE LEFT. VIEW COVERS ABOUT FOUR FEET VERTICALLY



CUTAWAY SKETCH OF DAM NO. 3, TO SHOW, IN SCHEMATIC FASHION, THE TYPE OF INTERNAL STRUCTURE RESULTING FROM THE CONSTRUCTION METHODS USED.

as "Three Forks") to be a typical narrow tributary valley with steep sides, although it widens somewhat at its mouth. This map is the only map reviewed which shows the topography of Middle Fork Valley before the refuse bank was started. The Middle Fork Valley area of this map is reproduced here as Figure V-6.

The dumping of coal refuse in Middle Fork Valley began in 1947 when the Lorado Mining Company completed its preparation plant on Buffalo Creek, about 3,500 feet upstream from Middle Fork. The solid refuse from this plant, 800 to 1,000 tons a day, was trucked to the mouth of Middle Fork Valley and dumped. Bulldozers graded the piles or dumped refuse to provide roadways and level areas on which the trucks placed the next layer of refuse piles. The refuse bank grew both vertically and up-valley almost continuously until construction of Dam No. 3 began. Houses in the valley were removed as the refuse bank encroached on them. The church at Saunders was moved several times to make way for the growing refuse bank. Figure V-7 is a diagrammatic sketch of Middle Fork Valley as it looked in late 1947 when the refuse bank was started.

The Army Map Service's Bluefield Sheet (scale 1:250,000), dated 1957, shows Saunders as "Three Forks." It does not indicate the presence of the Middle Fork refuse bank, probably because it was too small to be plotted at the map scale.

According to the Commission Report, Dam No. 1 began as a structure separate from the refuse bank: "The original dam was begun in May 1960. It was constructed by placing coal refuse partially across the valley at a point upstream from the then-existing refuse pile . . . Preparation plant waste water from the No. 5 preparation plant was pumped from a point on Buffalo Creek through the No. 5 mine and discharged into Middle Fork . . . The discharge point was located approximately 3,200 feet* above Dam No. 1." Figure V-8 is a diagrammatic sketch

*Figure V-10 indicates that the discharge point for the preparation plant effluent was about 5,000 feet upstream from Dam No. 1.

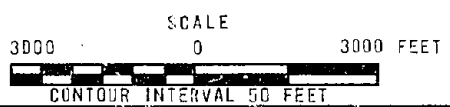
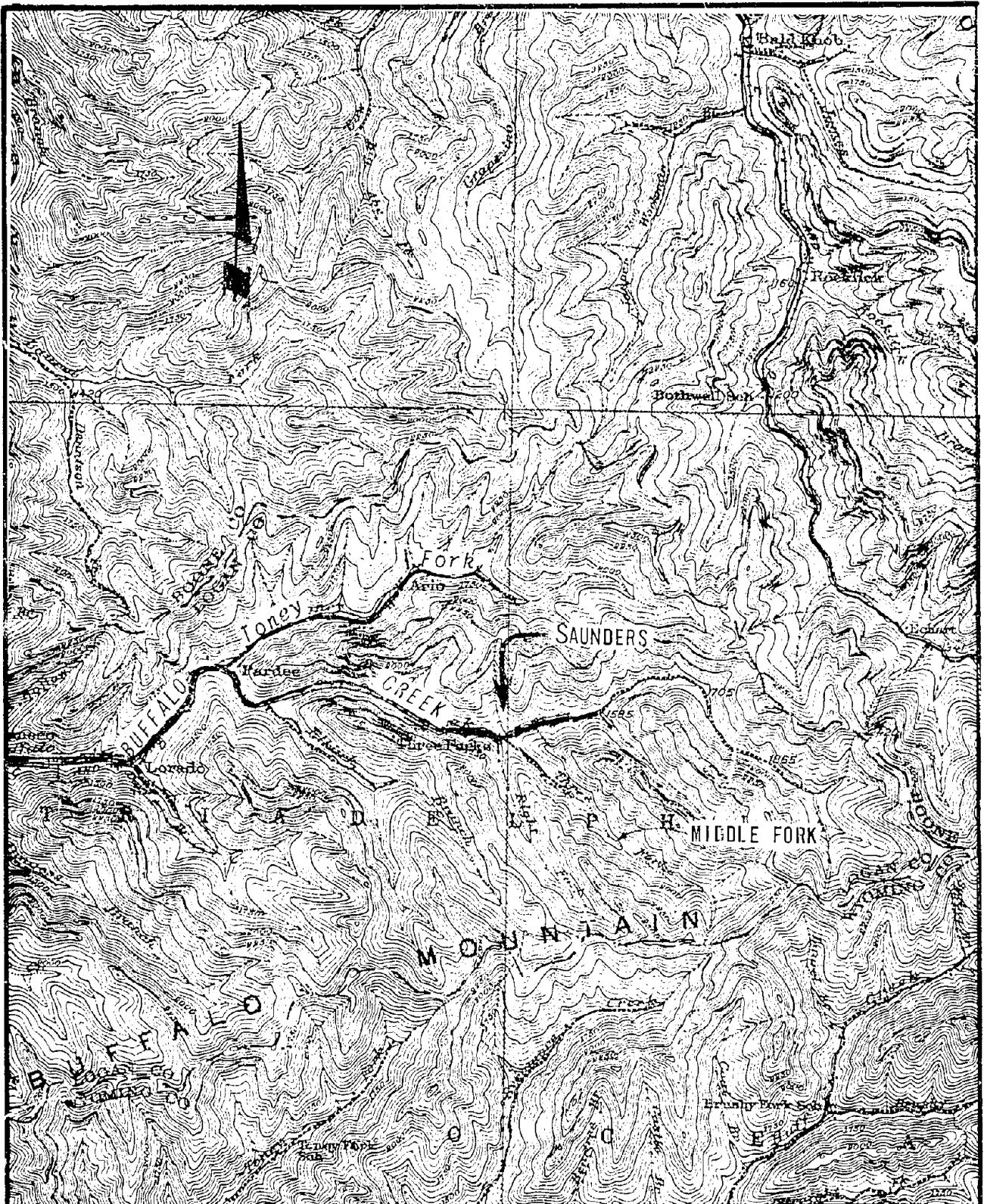

NOTE. MAP PUBLISHED IN 1914, LATEST REVISION 1928

W. A. WAHLER & ASSOCIATES	COAL REFUSE DAM FAILURE SAUNDERS, WEST VIRGINIA	PORTION OF BALD KNOB 15-MINUTE QUADRANGLE (U.S. GEOLOGICAL SURVEY)		
		PROJECT NO 0700	DATE NOVEMBER 1972	FIGURE NO V-6

PALO ALTO • NEWPORT BEACH • CALIF.



MIDDLE FORK VALLEY IN LATE 1947. THE REFUSE BANK HAS BEEN STARTED AT THE MOUTH OF THE VALLEY.

W. A. WAHLER
& ASSOCIATES

075

FIGURE V-7

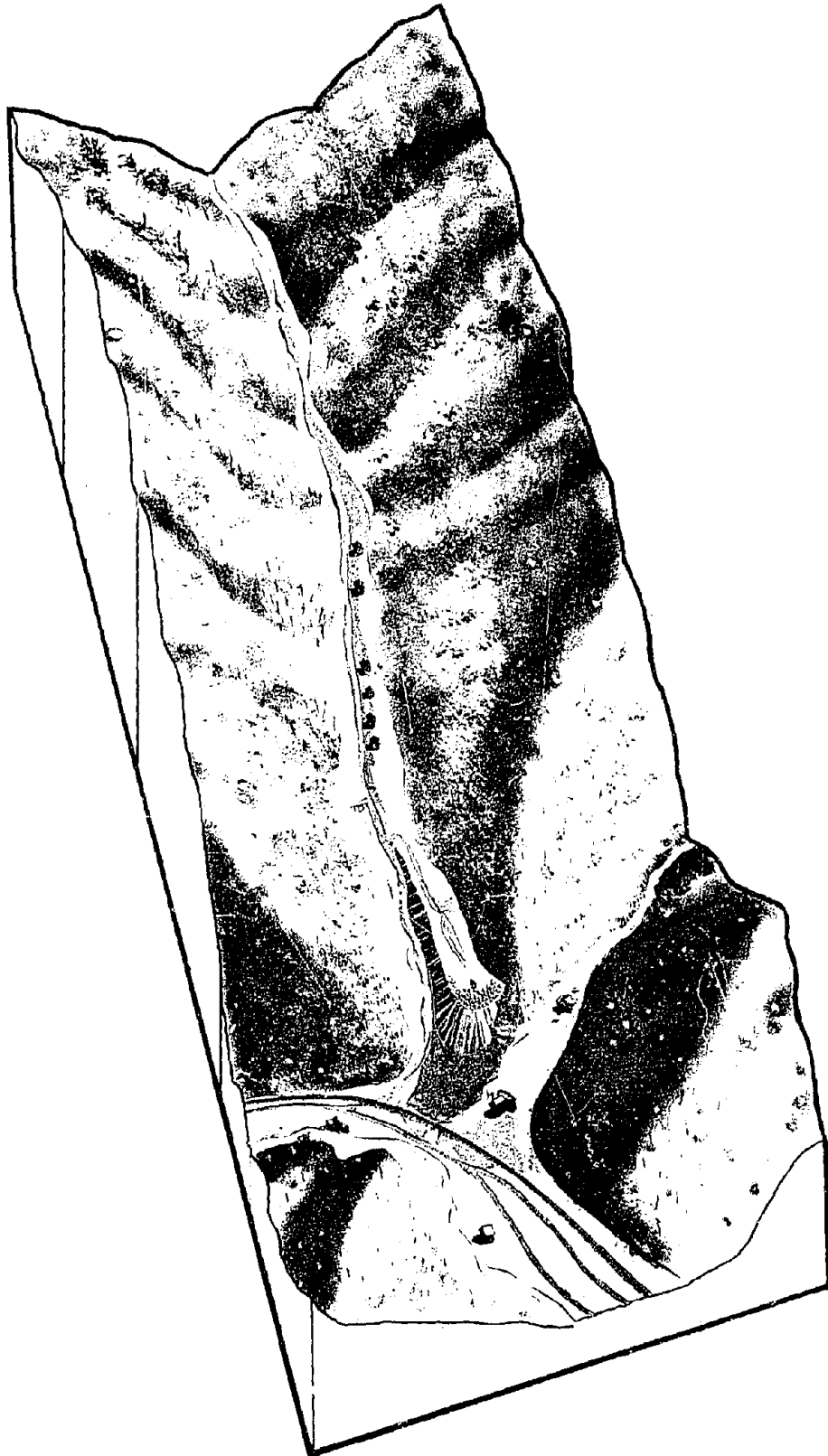

MIDDLE FORK VALLEY IN APRIL 1960. DAM NO. 1 HAS BEEN BUILT "AT A POINT UPSTREAM FROM THE THEN-EXISTING REFUSE PILE" (COMMISSION REPORT).

006

W. A. WAHLER
& ASSOCIATES

FIGURE V-8

showing the relationship between the first Dam No. 1 and the refuse bank. Dam No. 1 and its successors were constructed for the purpose of clarifying preparation plant discharge water, with a secondary advantage of providing some storage of water for plant use when Buffalo Creek was low.

In November, 1962, and January, 1963, aerial photography of the area for tax maps was flown by Michael Baker, Jr., Inc., of Beaver, Pennsylvania. Figure C-1 is a topographic map of the refuse bank and its impoundment on November 28, 1962, based on aerial photographs taken on that date. Figure V-9 is a diagrammatic sketch of Middle Fork Valley on November 28, 1962, based on Figure C-1.

Figure V-9 shows that by November 28, 1962, the refuse bank occupied virtually the entire flood plain of Middle Fork Valley, and Dam No. 1, as a structure separate from the refuse bank, did not exist; Dam No. 1 by this time (and subsequently) was actually a dike on (or extension of) the refuse bank. It is again emphasized that although this dike or extension is often called "Dam No. 1," the entire refuse bank acted as an impounding structure and the bank-plus-dike unit as a whole was really "Dam No. 1." The final location of the dike was different than the location of the original Dam No. 1; it appears to have progressed slightly upstream.

Stahl (1964) published a survey of burning coal mine refuse banks which was apparently conducted in 1962 or early 1963, so his data should at least roughly correlate to Figure C-1. He lists (p. 33) two refuse banks (numbers 95 and 97) described as being 0.1 mile from Saunders. Bank number 95 is described as 500 feet long, 250 feet wide, 60 feet high, and as active (i.e., in use to receive new coal waste) and burning rapidly. Number 97 is described as 400 feet long, 40 feet wide, 25 feet high, and as active and smoldering. It seems unlikely that either of these small refuse banks is the Middle Fork refuse bank,

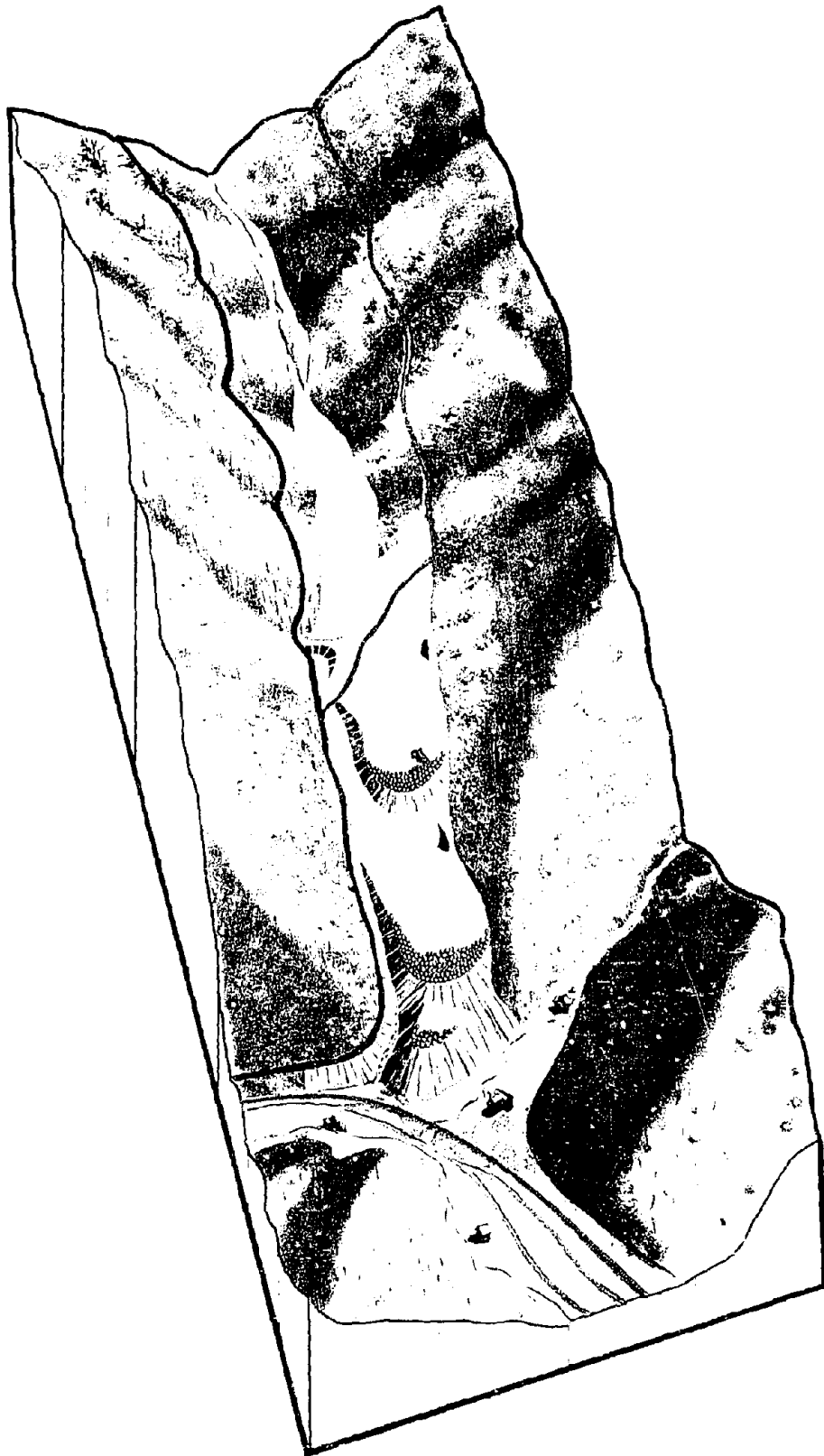

MIDDLE FORK VALLEY ON NOVEMBER 28, 1962. DAM NO. 1 AND THE REFUSE BANK ARE BOTH HIGHER AND HAVE PROGRESSED UPSTREAM. SKETCH BASED ON AERIAL PHOTOGRAPHS.

W. A. WAHLER
& ASSOCIATES

FIGURE V-9

shown on Figure C-1, which measures about 1,600 feet long and 250 feet wide and shows peaks at elevations of 1,648 and 1,686 feet above sea level, or about 148 and 186 feet, respectively, above the elevation of Saunders. Stahl's descriptions of banks 95 and 97, therefore, indicate banks far smaller than the Middle Fork bank of 1962. Stahl makes no mention of either refuse bank acting as an impoundment. It is likely that the "mine dump" about 0.1 mile west of Saunders (Figure V-10A) was, at the time of his work, actually two small dumps which later merged, and these were catalogued by him as numbers 95 and 97. Apparently Stahl missed the larger Middle Fork bank in his survey.

(Using Figure C-1 as a base, Figure C-2 shows the topographic configuration of the refuse bank on December 9, 1966, based on a sketch made that day by W. E. Davies of the U.S. Geological Survey. The beginnings of Dam No. 2 are also seen on Figure C-2).

The Commission Report describes the initial construction of Dam No. 2 as follows:

Buffalo Mining Company constructed Dam No. 2 in 1966 to replace Pool No. 1, which had been rendered useless due to extensive silting in the reservoir behind Dam No. 1 and the need for the company to find an additional space for disposing of the refuse. Dam No. 2 was located approximately 600 feet upstream from Dam No. 1 and was constructed by dumping refuse across the width of the hollow on the deposits remaining in the reservoir behind Dam No. 1. No effort was made to clear vegetation or trees prior to this dumping. Clarified water from this second dam . . . flowed into the remaining area behind Dam No. 1.

Figures V-10A, B, and C, based on portions of the 1968 Lorado (7.5 minute) quadrangle, show the configuration of the refuse bank, Dam No. 1, Dam No. 2 and their respective pools as of 1968. The locations of the Buffalo Mining Company tipple (preparation plant), the No. 5 Mine, and the discharge point for preparation plant waste water are also indicated.

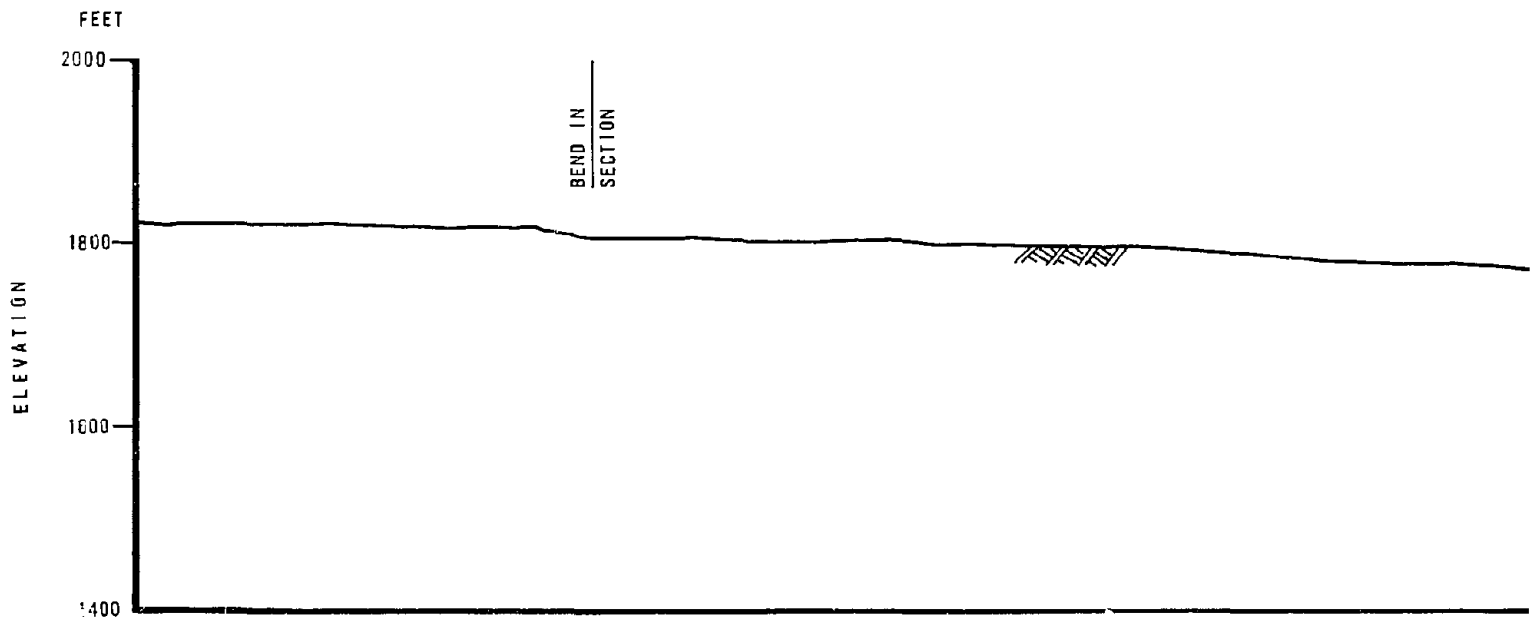
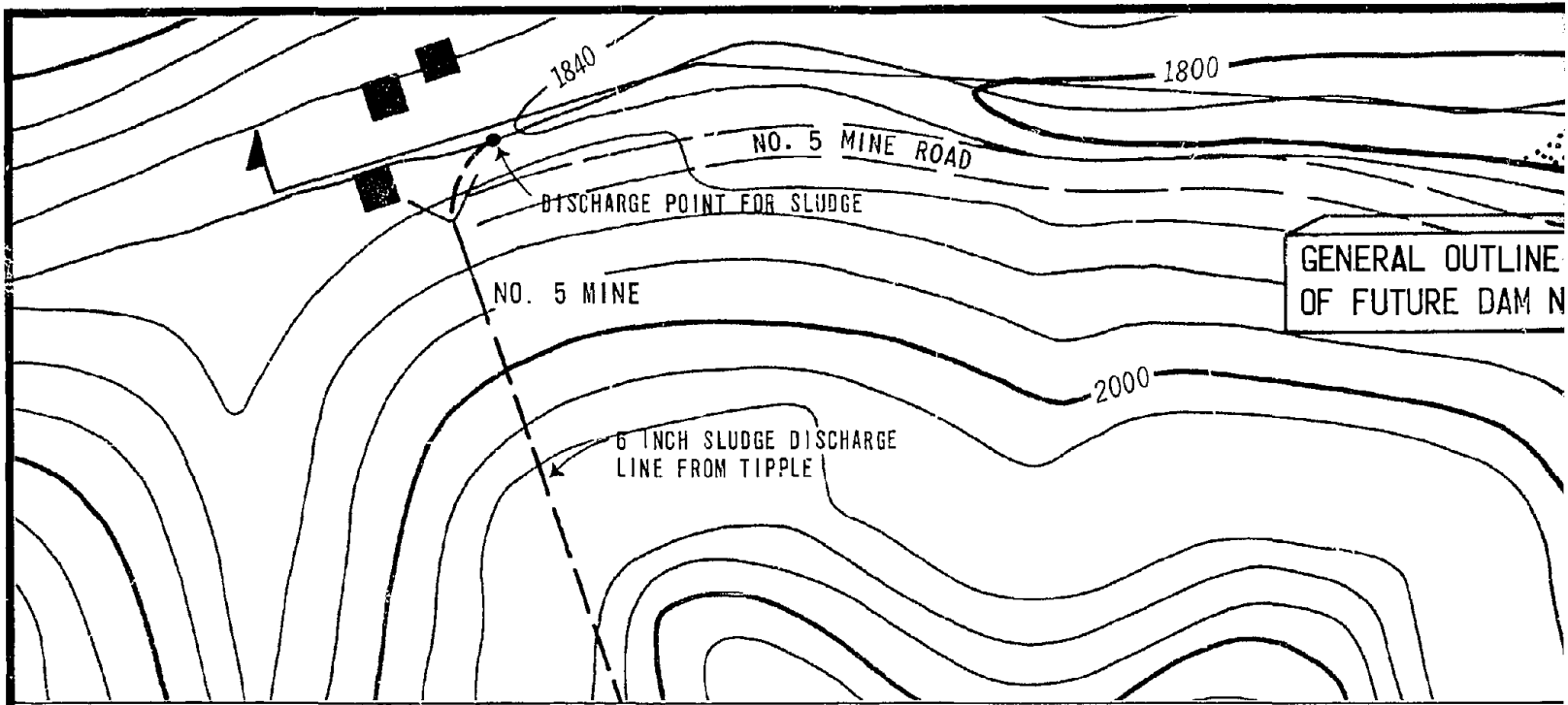

NOT

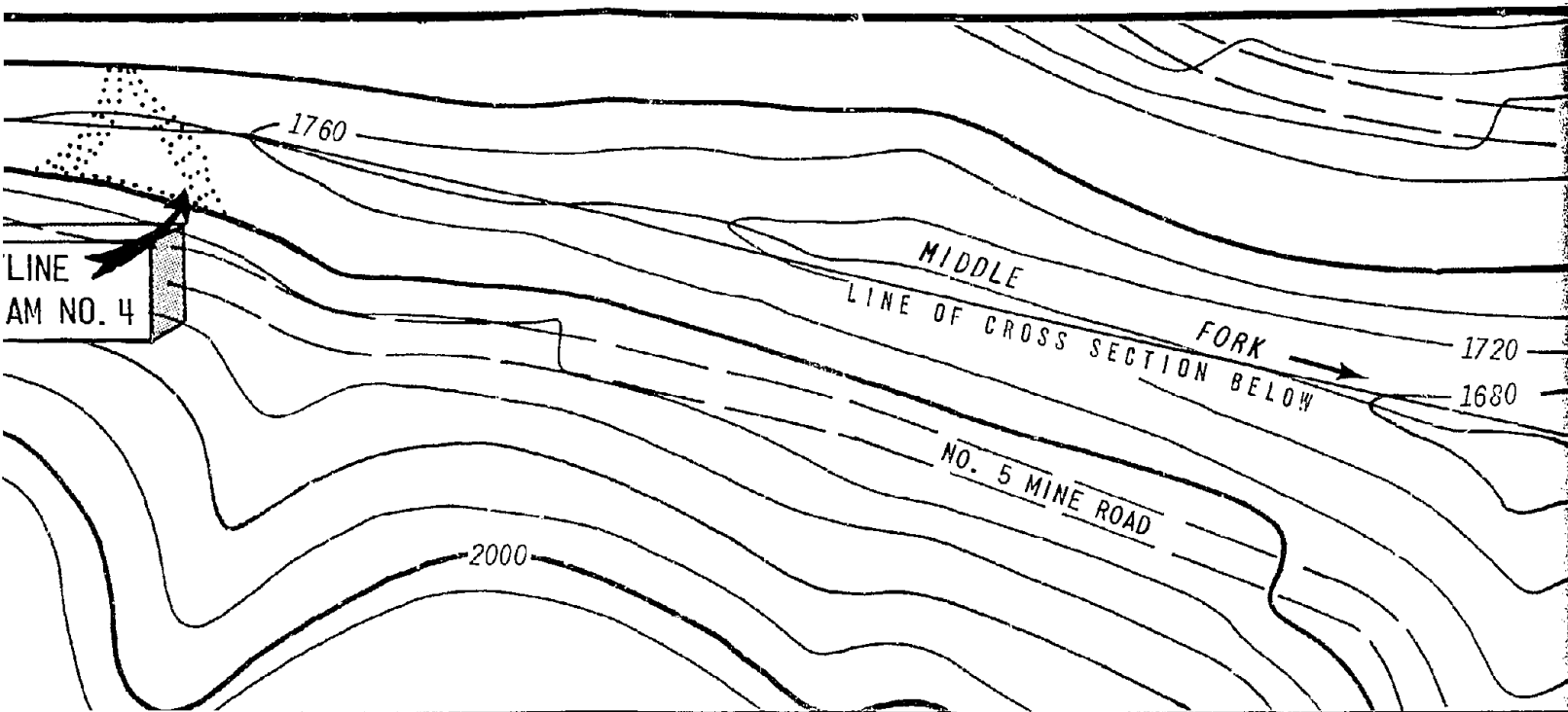

BEND IN
SECTION

//////

- NOTES: (1) NO POOL 2 SLUDGE SHOWN: IT WOULD BE VERY THIN IN EARLY 1968, THE TIME OF THIS CROSS SECTION.
 (2) SEE FIGURE V-11 A-D FOR DIAGRAMMATIC SKETCHES OF THE CONSTRUCTION HISTORY OF DAM NO. 2.

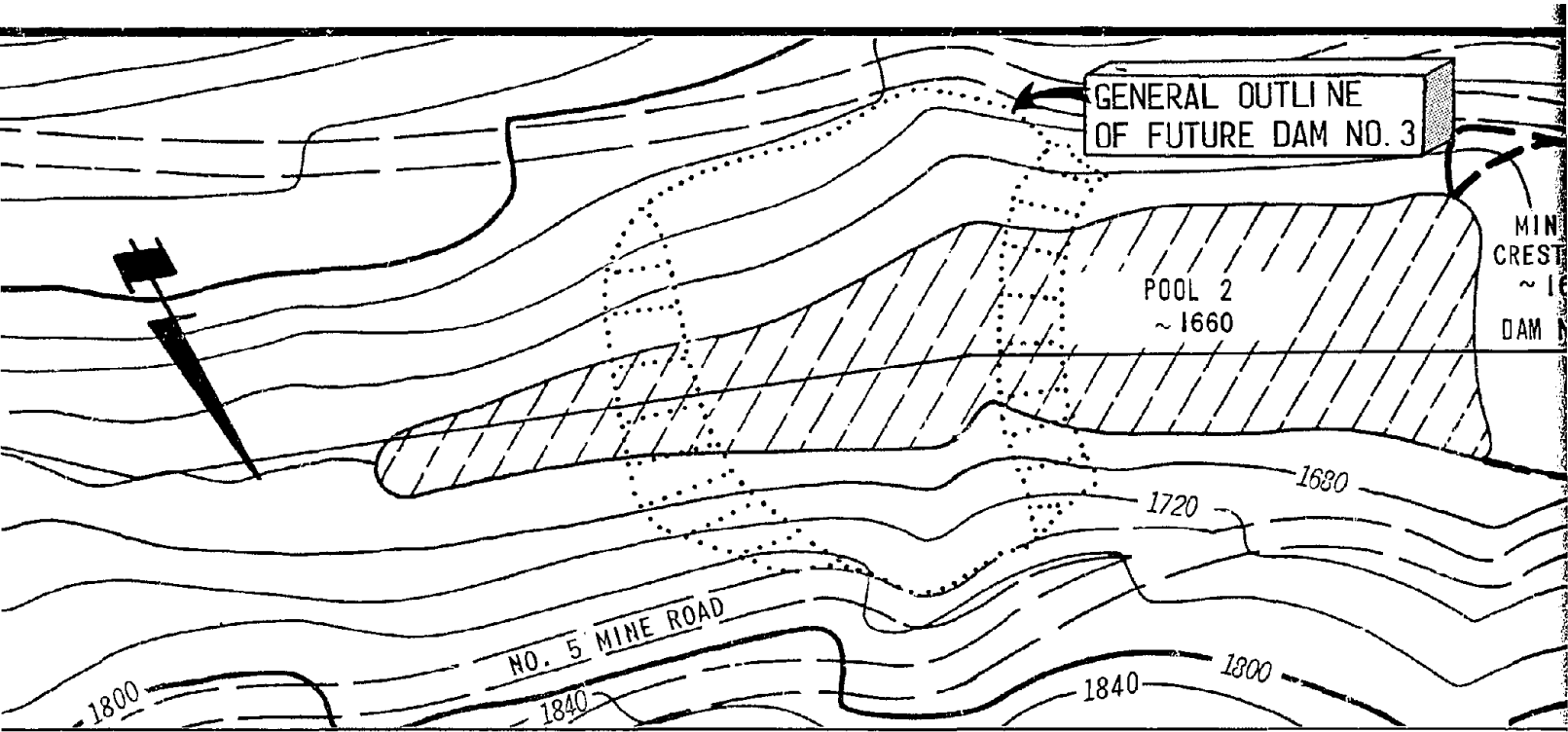

B. TOPOGRAPHIC MAP

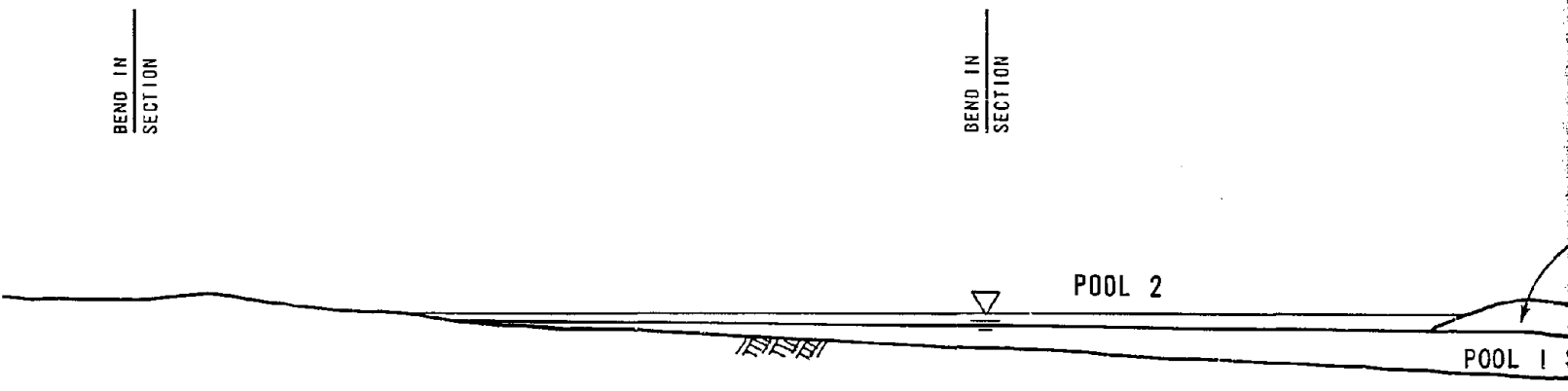

C. CROSS SECTION
(SEE MAP ABOVE)

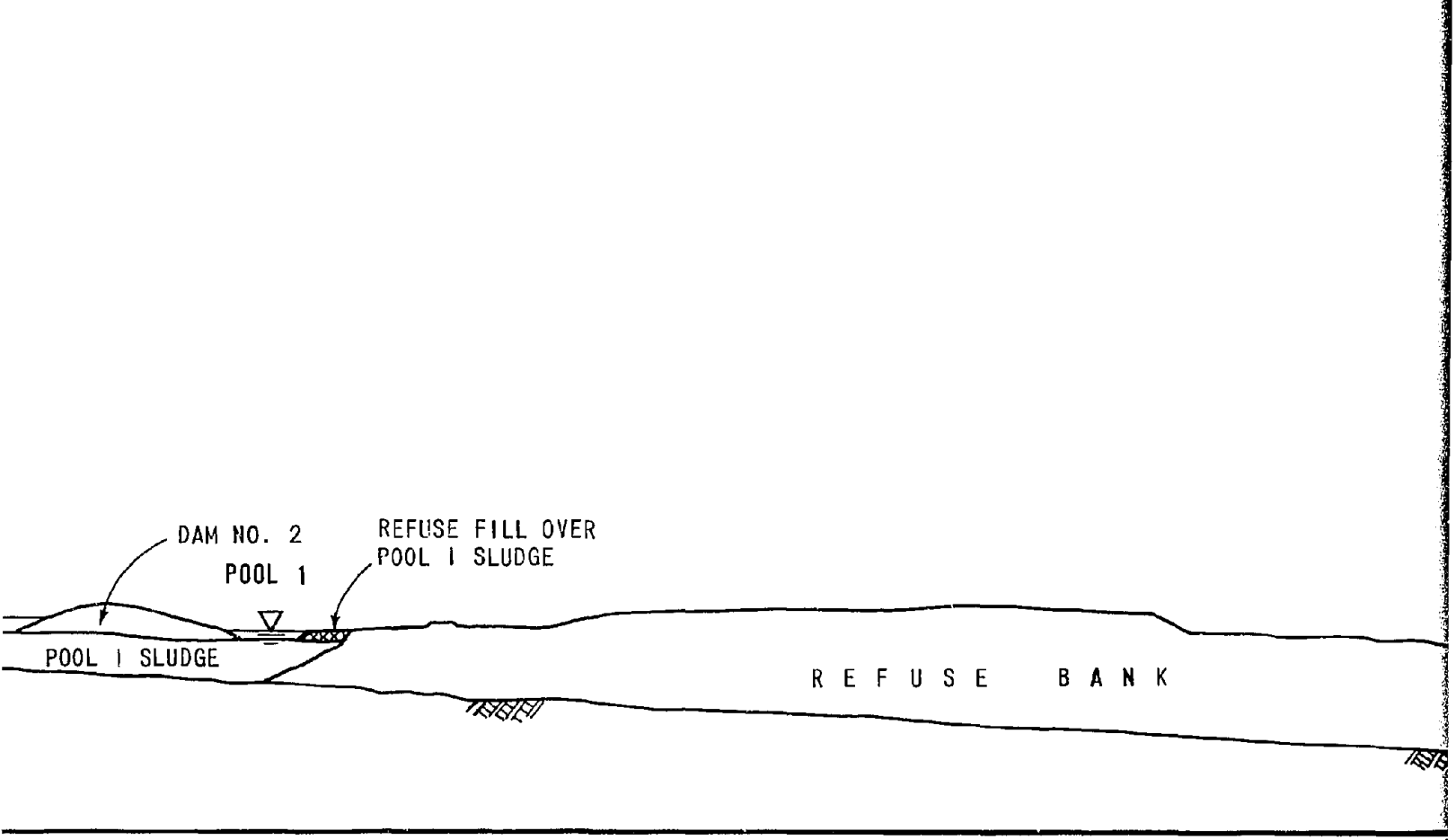
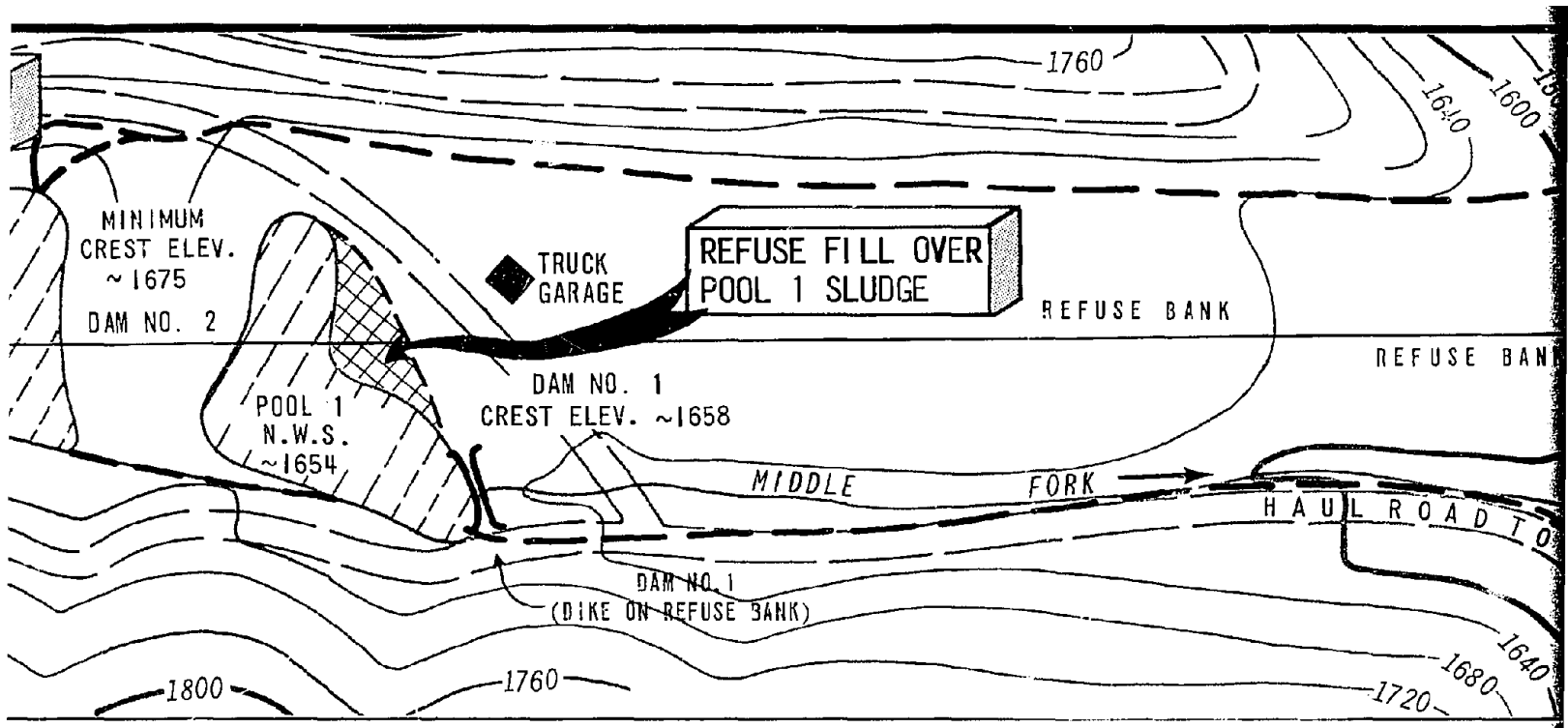

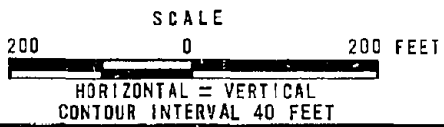
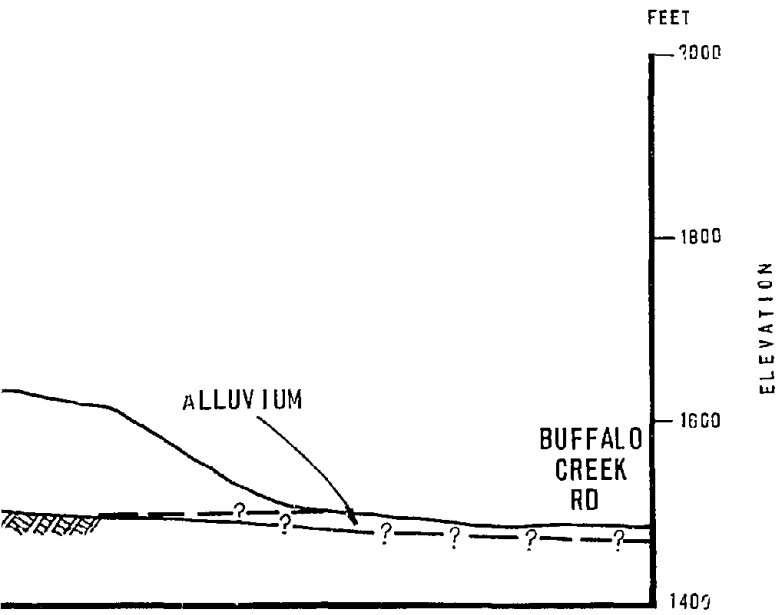
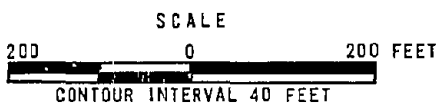
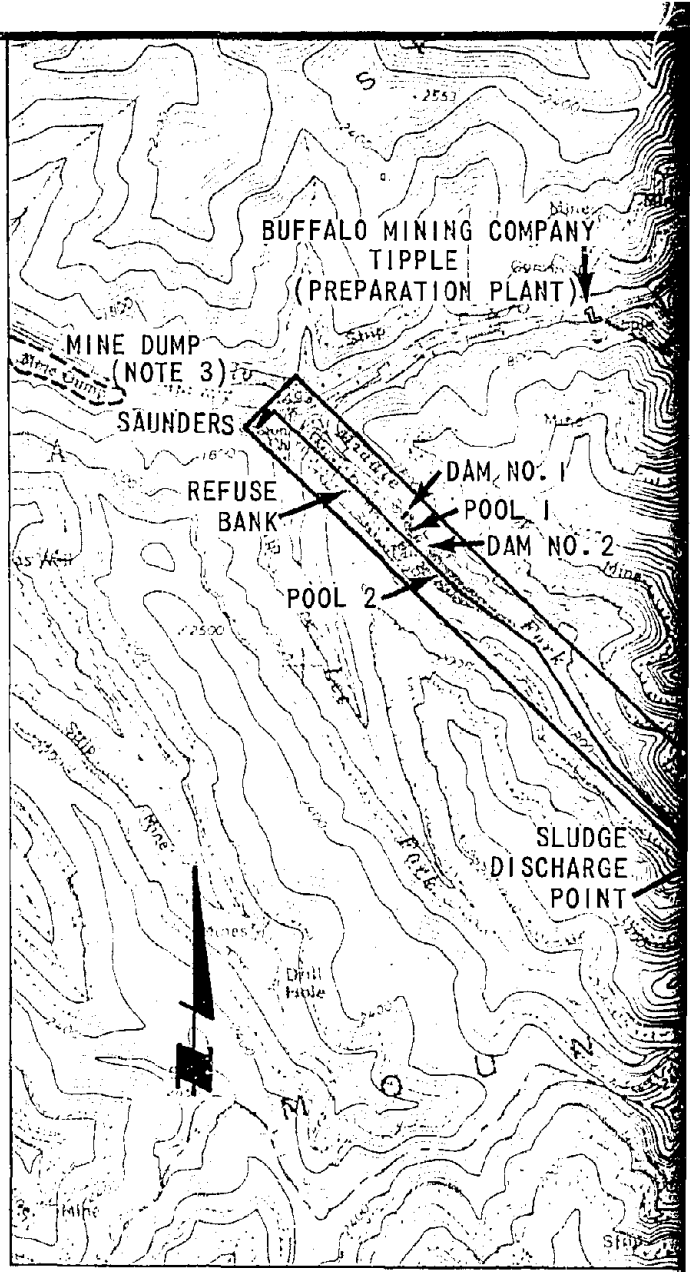
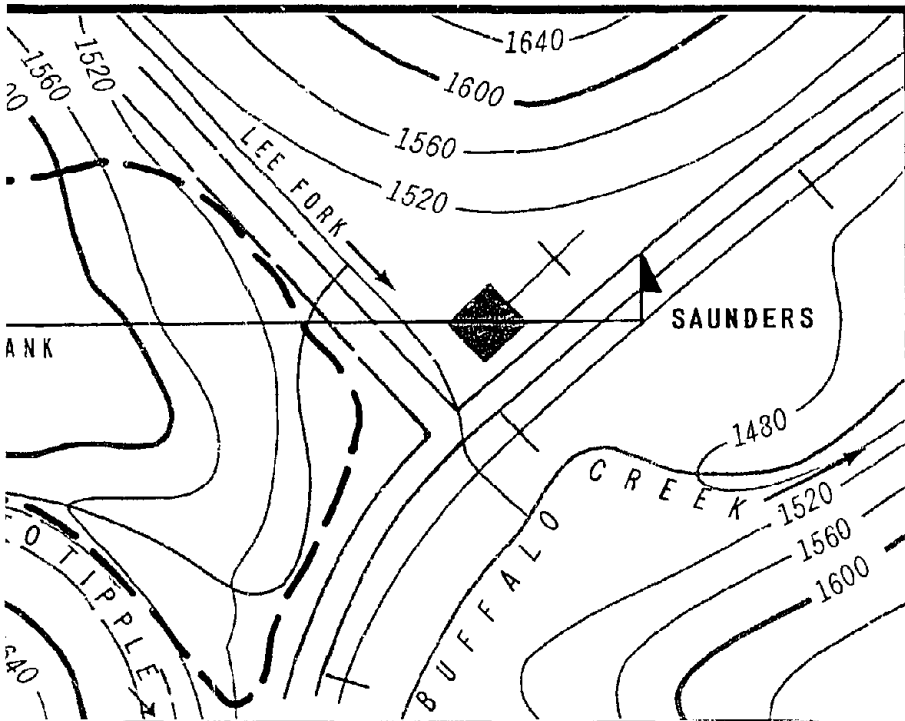

A. LOCATION

- NOTES:
- (1) FIGURE V-10A BASE F... LORADO QUADRANGLE,
 - (2) FIGURE V-10B DRAWN... QUADRANGLE ABOVE NOT
 - (3) POSSIBLE MINE DUMPS... SEE TEXT OF CHAPTER

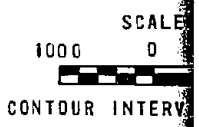

<p>W.A. WAHLER & ASSOCIATES</p>	<p>COAL REFUSE DAM FAILURE SAUNDERS, WEST VIRGINIA</p>
<p>PALO ALTO • NEWPORT BEACH • CALIF.</p>	

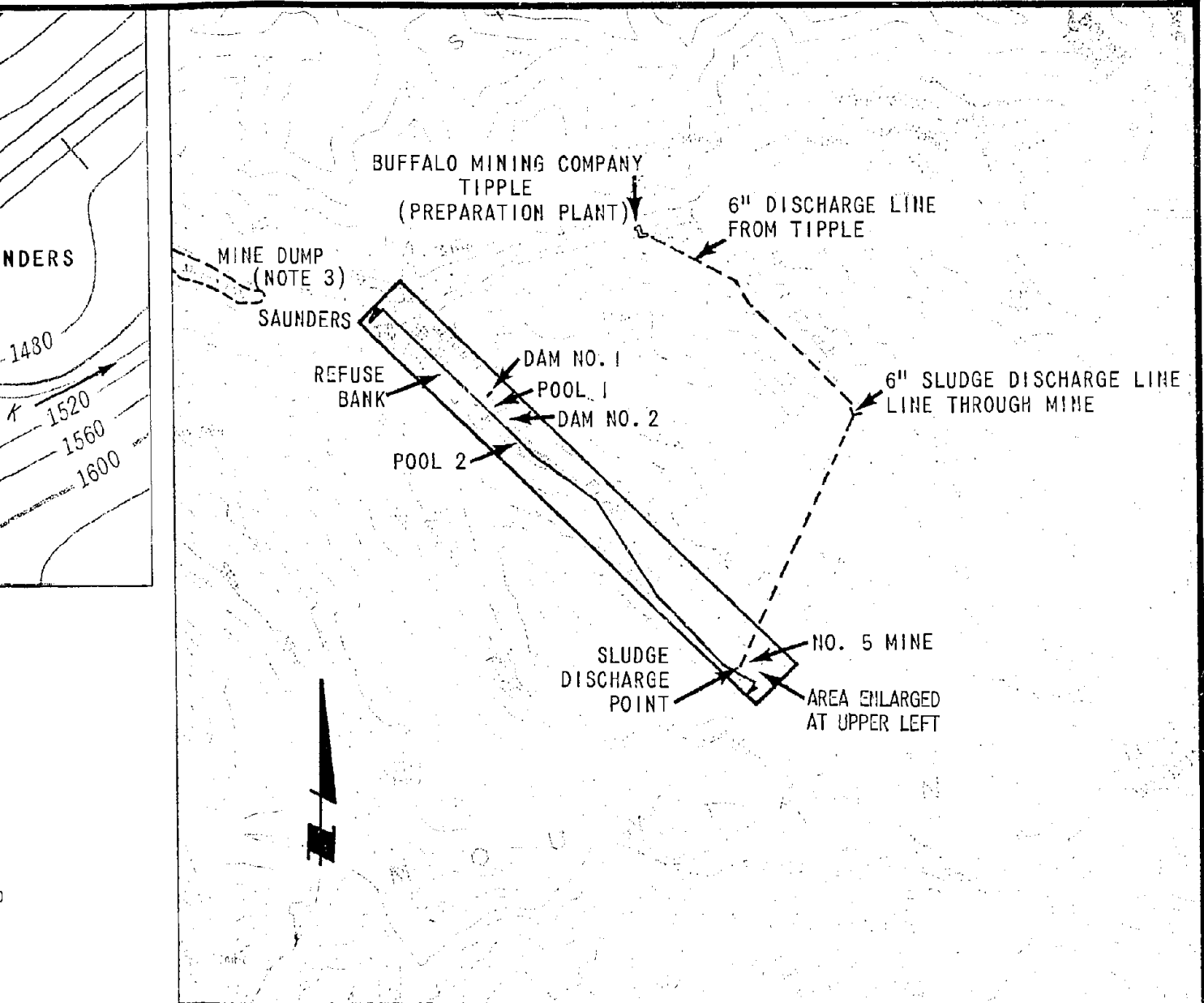

A. LOCATION MAP

- NOTES: (1) FIGURE V-10A BASE FROM U.S. GEOLOGICAL SURVEY LORADO QUADRANGLE, 1968.
 (2) FIGURE V-10B DRAWN FROM ENLARGEMENT OF LORADO QUADRANGLE ABOVE NOTED.
 (3) POSSIBLE MINE DUMPS 95 AND 97 OF STAHL (1964). SEE TEXT OF CHAPTER V FOR DISCUSSION.

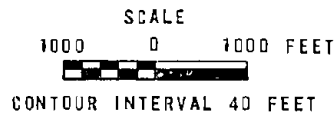

60

W.A. WAHLER & ASSOCIATES	COAL REFUSE DAM FAILURE SAUNDERS, WEST VIRGINIA	TOPOGRAPHIC MAP & CROSS SECTION, 1968		
		PROJECT NO. 0700	DATE NOVEMBER 1972	FIGURE NO. V-10 A, B, C

PALO ALTO • NEWPORT BEACH • CALIF.

ELEVATION

A series of diagrammatic sketches (Figures V-11A through V-11D) illustrates the growth of Dam No. 2. Dam No. 2 started from the left side of the valley (Figure V-11A) and was incomplete when the March 1967 overtopping of Dam No. 1 occurred. The flow after Dam No. 1 failed eroded portions of the Dam No. 2 embankment (Figure V-11B). Dam No. 2 was then completed across the valley and Dam No. 1 repaired (Figure V-11C) by mid-1967. A 30-inch overflow pipe was installed in Dam No. 2 about this time. The pipe discharged into a ditch on the right side of the No. 5 Mine Road as shown on Figure V-11C.

Probably starting in 1967, the left side of Pool 1 was filled in by extending the refuse bank upstream (Figure V-11D) until it covered the left half of the downstream face of Dam No. 2. Thus, the refuse bank grew up-valley over Pool 1 sludge and became a functional part of Dam No. 2, as well as a part of Dam No. 1. Figures V-10B and V-10C show this upstream growth of the refuse bank over Pool 1 sludge in map and section view, respectively. In 1968, the minimum crest elevation of Dam No. 2 was about 1,675 feet. Postfailure mapping indicates that the 1972 prefailure minimum crest elevation for Dam No. 2 was about 1,690 feet, indicating Dam No. 2 was raised about 15 feet above its initial crest elevation. Figure V-12 shows an overall view of Middle Fork Valley in early 1968, after Dam No. 2 was completed and before Dam No. 3 was started.

2. After Start of Dam No. 3 (1968-1972)

With the completion of Dam No. 2 in late 1967, the stage was set for construction of Dam No. 3, which would continue the progressive upstream damming of Middle Fork Valley. On February 26, 1968, D. S. Dasovich, Vice President of Buffalo Mining Company, sketched out Dam No. 3 during a field inspection with representatives from the West Virginia Public Service Commission (Mr. Harold Snyder) and the West Virginia Department of Natural Resources (Mr. Joseph C. Holly). His sketch, reproduced from the Commission Report, is included here as Figure V-13. During this

61

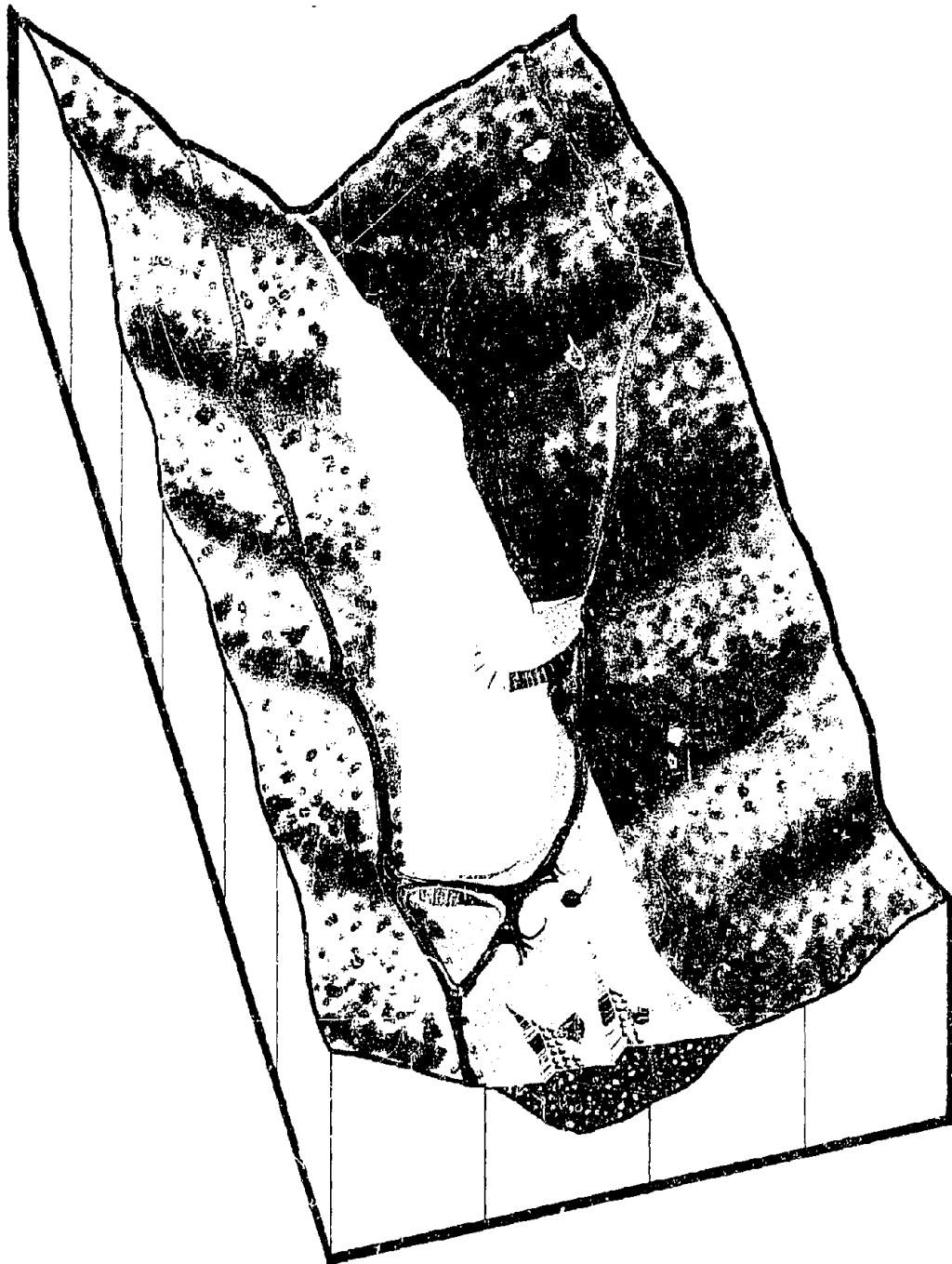

MIDDLE FORK VALLEY, DECEMBER 1966, LOOKING UPSTREAM. DAM NO 2 HAS BEEN STARTED AND EXTENDS INTO POOL 1.

W.A. WAHLER
& ASSOCIATES

FIGURE V-11A



MIDDLE FORK VALLEY, MARCH 1967, LOOKING UPSTREAM. DAM NO. 1 HAS FAILED BY OVERTOPPING. DAM NO. 2 SUFFERS EROSION AND SLUMPING THROUGH INCOMPLETE AT THIS TIME.

63

W.A. WAHLER
& ASSOCIATES

FIGURE V-11B

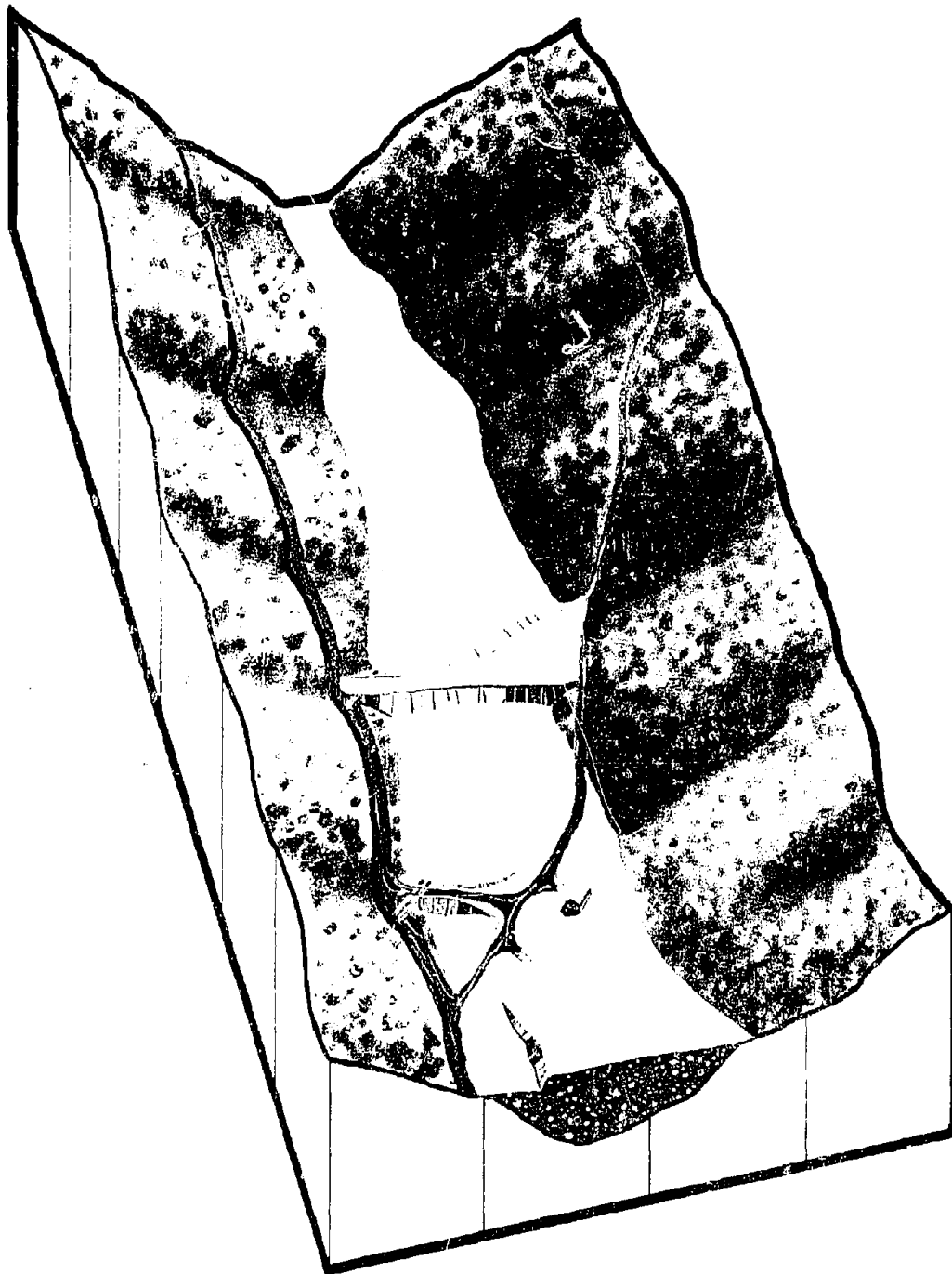

MIDDLE FORK VALLEY IN MID-1967, LOOKING UPSTREAM. DAM NO. 2 HAS BEEN COMPLETED WITH A CREST ELEVATION OF ABOUT 1675 FEET. OVERFLOW PIPES HAVE BEEN INSTALLED IN DAMS 1 AND 2.

W.A. WAHLER
& ASSOCIATES

FIGURE V-11C



MIDDLE FORK VALLEY IN LATE 1967, LOOKING UPSTREAM. THE REFUSE BANK IS BEING EXTENDED UPSTREAM OVER PART OF POOL I.

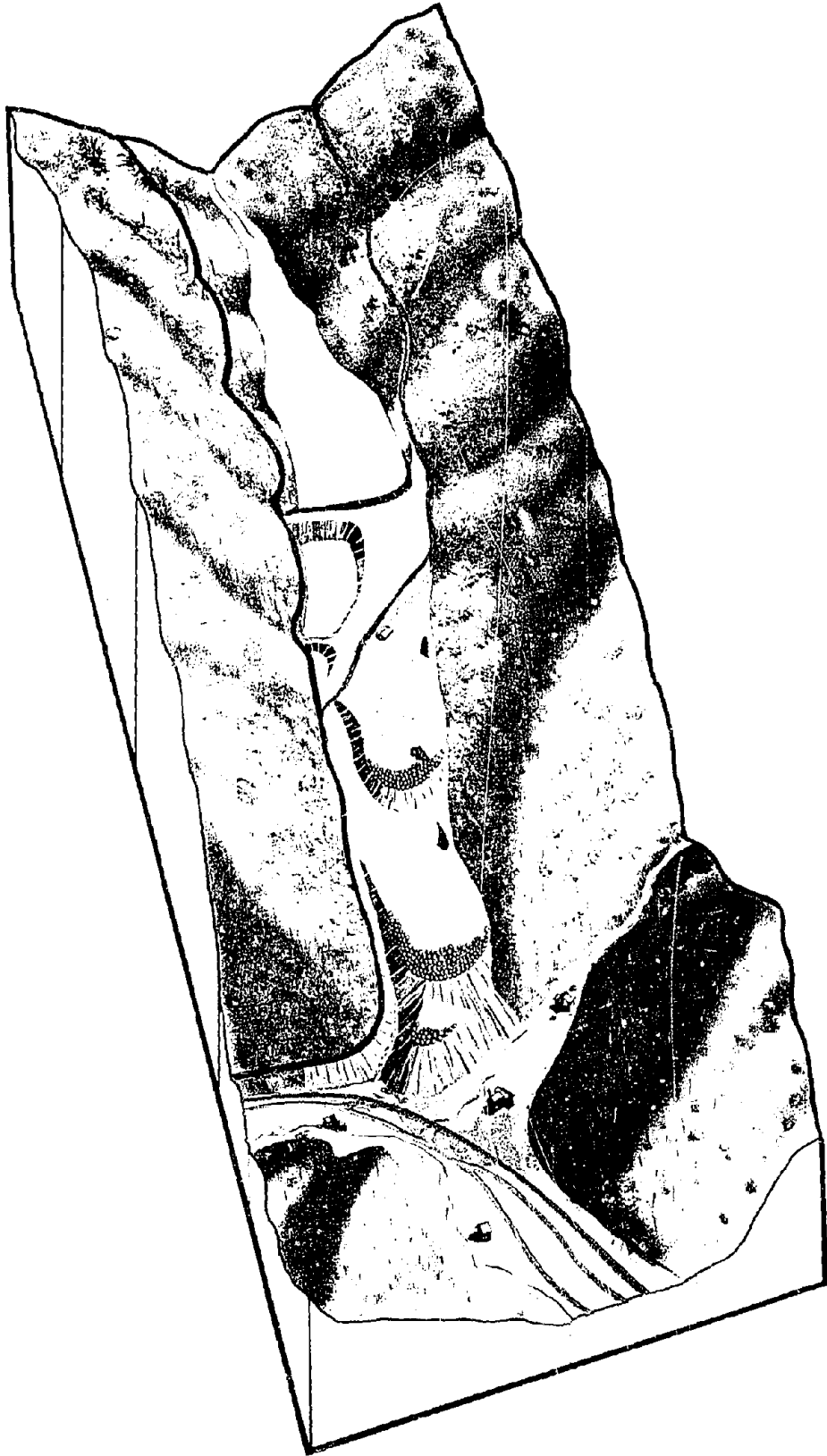

MIDDLE FORK VALLEY IN EARLY 1968

66

W.A. WAHLER
& ASSOCIATES

FIGURE Y-12

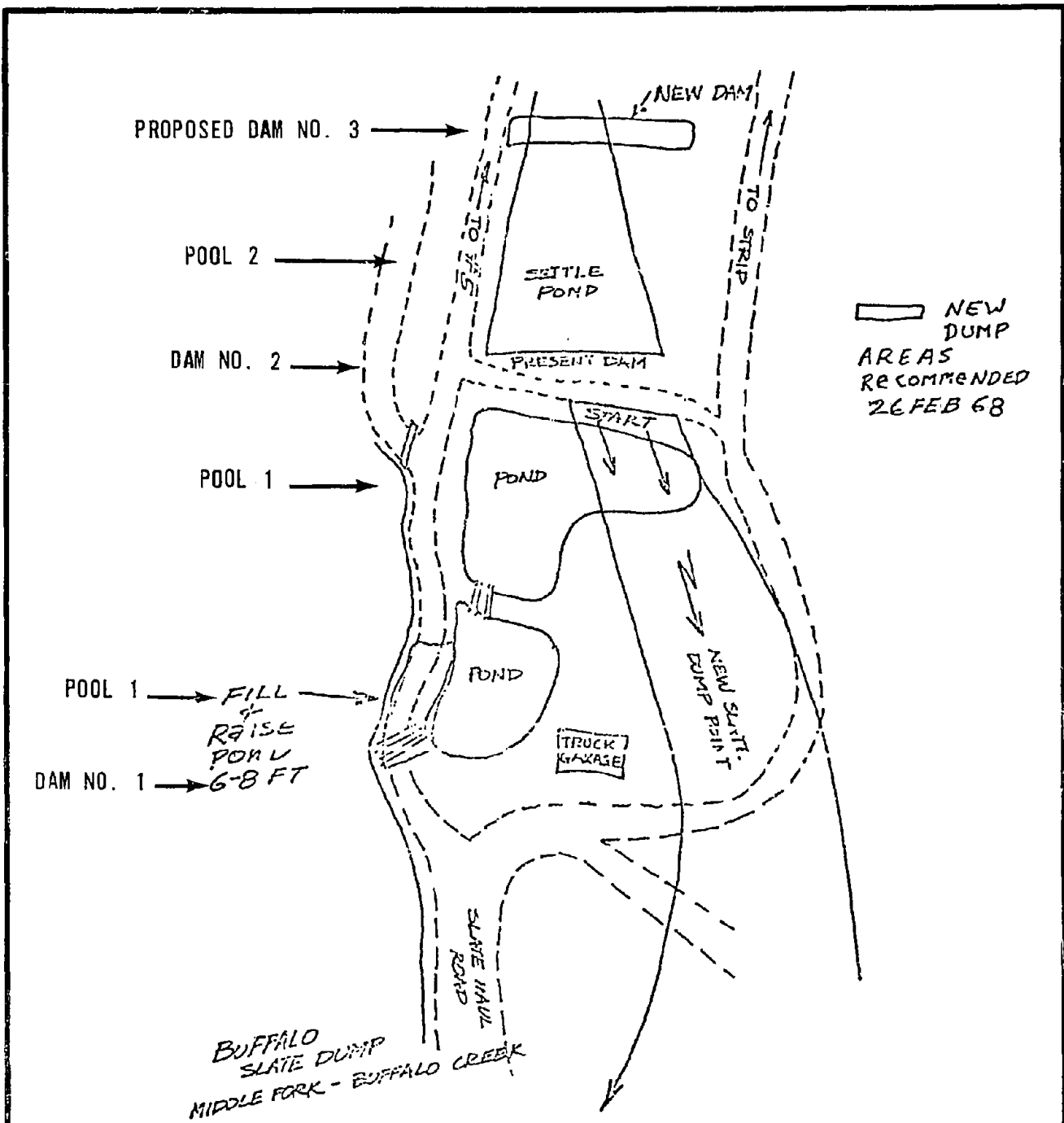

THIS SKETCH WAS MADE BY D. S. DASOVICH, VICE-PRESIDENT OF BUFFALO MINING COMPANY, ON FEBRUARY 26, 1968. IT SHOWS THE PROPOSED "NEW DAM" (DAM NO. 3). POOL 1 IS INDICATED AS TWO SEPARATE PONDS AT THAT TIME.
 SOURCE: WEST VIRGINIA AD HOC COMMISSION OF INQUIRY INTO THE BUFFALO CREEK FLOOD, 1972a.

67

W.A. WAHLER & ASSOCIATES	COAL REFUSE DAM FAILURE SAUNDERS, WEST VIRGINIA	DASOVICH'S SKETCH		
		PROJECT NO 0700	DATE NOVEMBER 1972	FIGURE NO. V-13

PALO ALTO • NEWPORT BEACH • CALIF.

inspection, Mr. Snyder reportedly recommended that Dam No. 2 be raised. The company most likely followed this recommendation because, as noted above, the 1972 prefailure crest elevation of Dam No. 2 was about 15 feet higher than shown on the 1961 Lorado quadrangle (Figure V-10B).

During the February 26, 1968 conference, according to the Commission Report, Mr. Dasovich suggested that as an alternative to a new dam (Dam No. 3), Dam No. 2 could be widened and heightened by extending it upstream. As the Ad Hoc Commission reports:

However, in a Notice to Comply with Water Pollution Control Permit, issued by the West Virginia Department of Natural Resources against Buffalo Mining Company, dated March 28, 1968, one of the deficiencies noted is as follows: ". . . 9. Put in proposed refuse dump further up hollow behind impoundment to act as a retaining dam for solids in plant effluent ejected above and this refuse dump will also slow down surface runoff." In a letter of compliance dated May 29, 1968, Mr. Dasovich notified the West Virginia Department of Natural Resources that work has begun on Dam No. 3 and that it would ". . . be completed in the very near future."

Diagrammatic sketches (Figures V-14A through H) are used to trace the history of Dam No. 3 from its start in May 1968. Trucks dumped coal refuse from a wide area in the No. 5 Mine Road on the right side of the valley, and a platform was made (Figure V-14A) from which trucks could dump either down the face or into individual piles for later leveling by a bulldozer. This platform became the right end of Dam No. 3. The embankment was carried across Middle Fork Valley from right to left (as viewed looking downstream) at approximately Elevation 1,740-1,750 (Figure V-14B).

In February 1969, a large slump occurred on the advancing face of the embankment (Figure V-14C). This failure is described as "that whole end of the dam, 100 feet of it, disappeared" (U.S. Congress, 1972b, p. 318). This failure was not directly related to seepage forces in

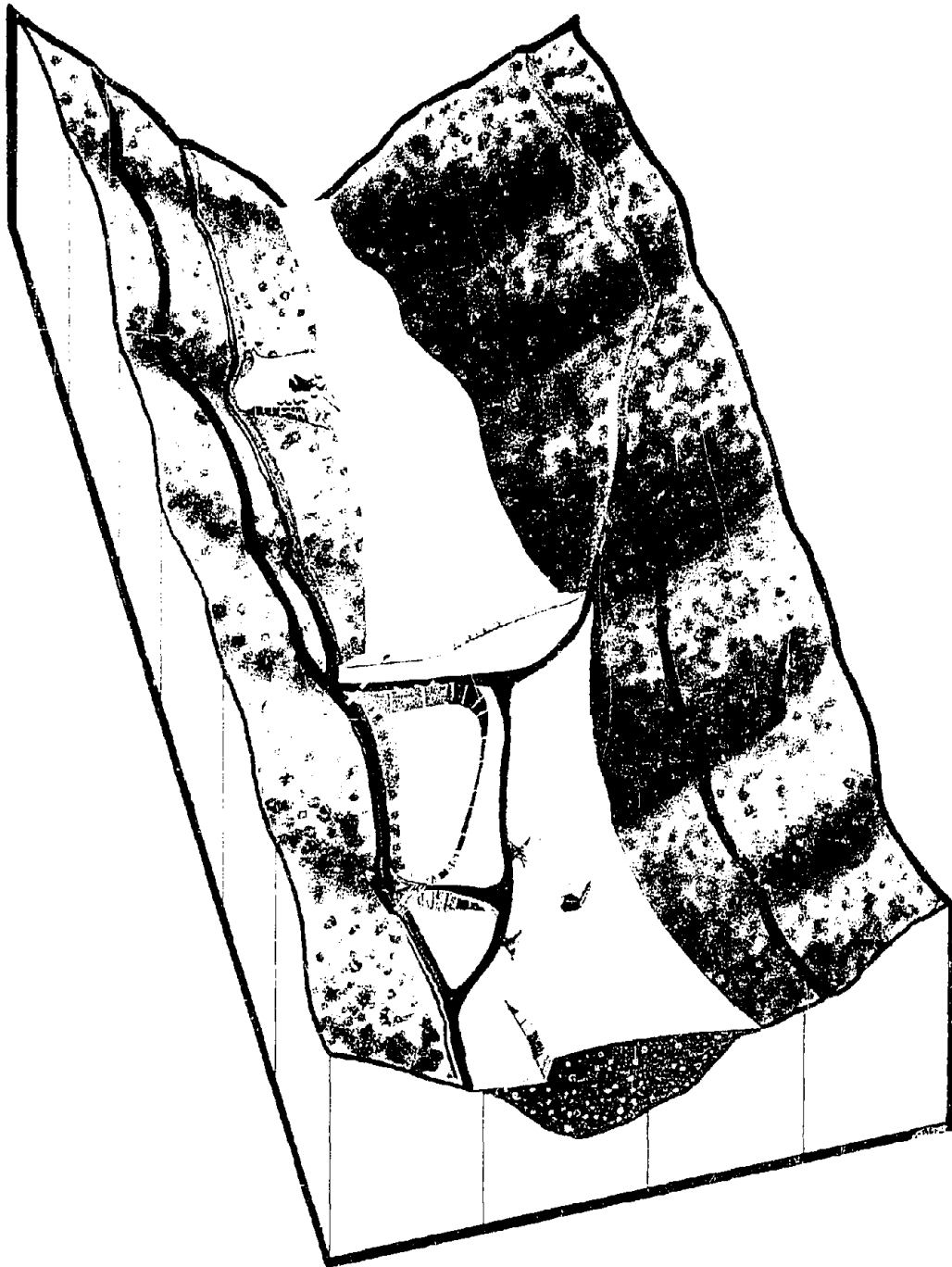

MIDDLE FORK VALLEY IN MID-1969, LOOKING UPSTREAM
A PLATFORM OF COAL WASTE AT ITS RIGHT ABUTMENT.
MAXIMUM EXTENT AND COVERS ONE-HALF OF POOL 1.

DAM NO. 3 IS STARTED BY BUILDING
THE REFUSE BANK HAS REACHED ITS

W. A. WAHLER
& ASSOCIATES

FIGURE V-14A



MIDDLE FORK VALLEY IN LATE 1968, LOOKING UPSTREAM. THE DAM NO. 3 EMBANKMENT HAS PROCEEDED OVER POOL 2 SLUDGE.

W. A. WAHLER
& ASSOCIATES

FIGURE V-14B



MIDDLE FORK VALLEY, FEBRUARY 1969, LOOKING UPSTREAM. THE ADVANCING FACE OF THE DAM NO. 3 EMBANKMENT HAS FAILED.

W. A. WAHLER
& ASSOCIATES

FIGURE V-14C



MIDDLE FORK VALLEY IN SPRING 1969, LOOKING UPSTREAM. THE FAILURE OF THE EMBANKMENT IS REPAIRED BY CONTINUING TO DUMP INTO THE SLUMPED AREA.

W.A. WAHLER
& ASSOCIATES

FIGURE V-140



MIDDLE FORK VALLEY IN EARLY 1970, LOOKING UPSTREAM. DAM NO. 3 IS COMPLETED ACROSS THE VALLEY, BUT NOT TO ITS FULL WIDTH OR HEIGHT. BULLDOZERS RAISE THE DAM BY LEVELING DUMPED PILES OF COAL REFUSE.

W. A. WAHLER
& ASSOCIATES

FIGURE V-14E

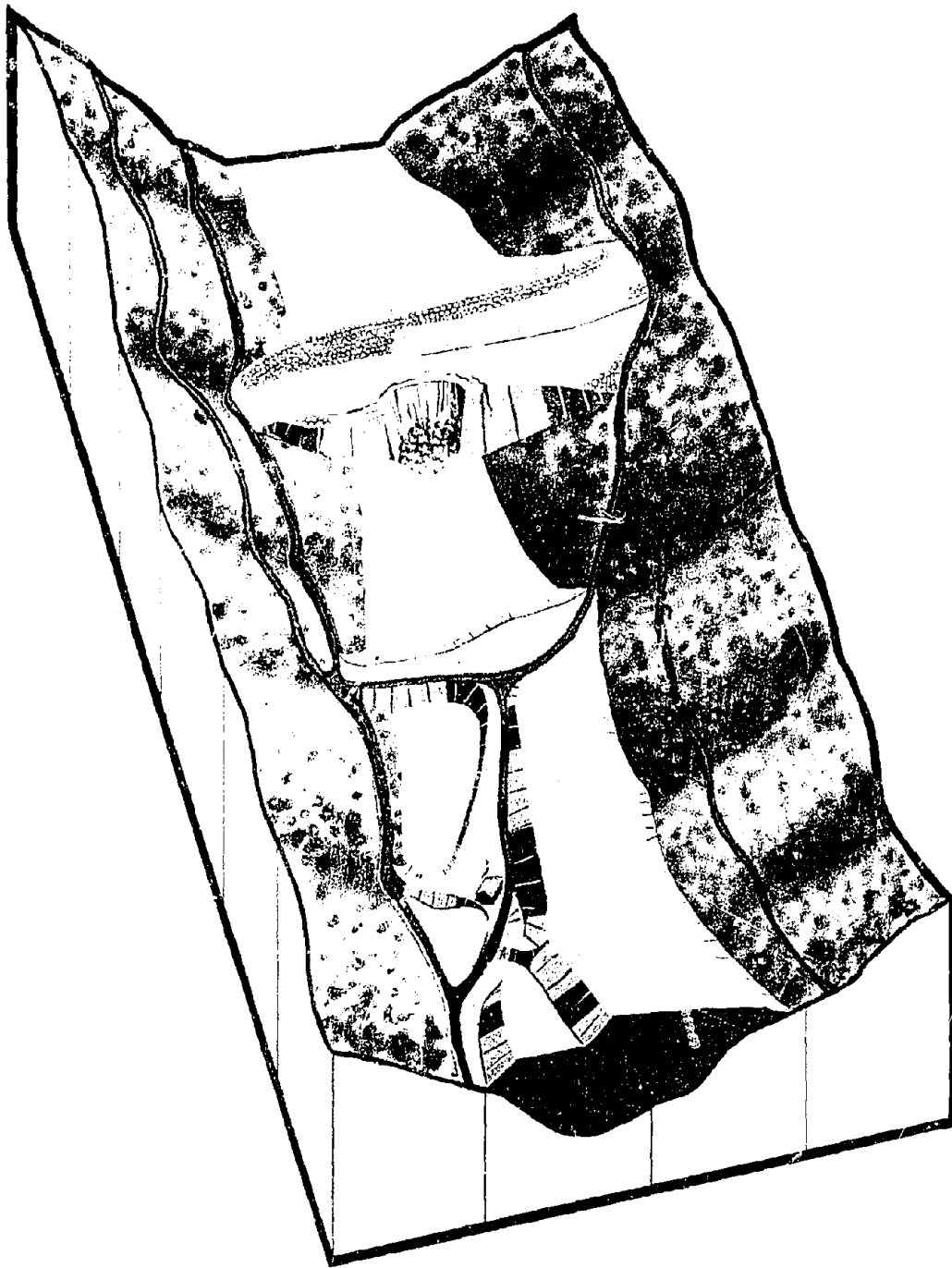

MIDDLE FORK VALLEY IN FEBRUARY-MARCH, 1971, LOOKING UPSTREAM. DAM NO. 3 EXPERIENCES SLUMPING ON THE DOWNSTREAM FACE.

W.A. WANLER
& ASSOCIATES

FIGURE V-14F



MIDDLE FORK VALLEY IN MARCH 1971, LOOKING UPSTREAM. THE FAILURE OF DAM NO. 3 IS REPAIRED BY FILLING IN THE SLUMPED AREA.



76

MIDDLE FORK VALLEY IN EARLY FEBRUARY 1972, LOOKING UPSTREAM. POOL 3 HAS A SURFACE ELEVATION OF ABOUT 1740-1745 FEET.

the embankment because the embankment did not close off the valley at that time. The phreatic surface throughout the incomplete dam was essentially at the level of the water in Pool 2. This February 1969 failure was a foundation failure: the sludge foundation below the embankment simply yielded under the weight of the embankment imposed on it. It is unlikely that the embankment materials would sink completely through the accumulated sludge and "find bottom" as a coherent block; and our subsurface exploration found no indication that this occurred. From the description given in the testimony, we think the sludge yielded and flowed laterally, and the embankment sank and also spread laterally. Although the end of the embankment "disappeared," it did not sink a great distance, but stopped with its top generally between the water level of Pool 2 and the former top of the Pool 2 sludge. The slide was "repaired" (Figure V-14D) by simply continuing to dump more refuse on top of the embankment-sludge mixture that resulted from the failure.

By early 1970, Dam No. 3 was a true dam, extending completely across Middle Fork Valley (Figure V-14E). Prior to this closure, some refuse dumping may have occurred from the left abutment side; after closure, refuse trucks could approach the dam from either abutment. Which road the trucks travelled depended on traffic or road conditions, but they generally travelled up the No. 5 Mine Road, crossed the dam after dumping their loads, and came down the other side of the valley. Bulldozers both raised the embankment by leveling groups of piles and advanced it downstream and upstream by pushing edge-dumped piles down the face.

In June 1970, a team from the Pittston Company examined or "surveyed" the Buffalo Mining Company properties. Testimony indicates that they found nothing wrong with any of the Middle Fork dams. Dam No. 3 was reported to be "50 percent complete" at that time (Commission Report) but this figure probably refers to the volume completion of the dam

15 77

since other information indicates that closure was effected early in 1970. Work continued on Dam No. 3 after Pittston acquired Buffalo Mining Company. Dam No. 3 was raised and widened throughout the remainder of 1970.

By 1971 or earlier, dumping off the left portion of the downstream face of Dam No. 2 and advancement of the refuse bank from below had filled in the left half of Pool 1. This action had a buttressing effect on the left portion of Dam No. 2, but in February 1971, the right portion "cracked down the middle and slumped" (Commission Report). Like other slumps, this one was repaired by dumping more refuse into the void created by the slump. In this case, the dam was reportedly also widened by additional dumping on the upstream face.

Dam No. 3 reportedly reached its final height by February 1971. After this juncture, further dumping widened the dam by adding refuse to the upstream and downstream faces. In February or March 1971, a relatively shallow failure occurred on the downstream face of Dam No. 3 (Figure V-14F). This slide is described as being "150 to 200 feet wide across the face of the dam and 20 to 30 feet from the face back" (Commission Report). Again the slide was repaired by dumping more refuse down the scarp and refilling the void left by the slide (Figure V-14G).

The final important feature in the construction history of Dam No. 3 is the reported placement of a 24-inch spillway pipe in the embankment. This apparently occurred during the period April-June 1971. The reported existence of this spillway has been challenged (Citizens Commission to Investigate the Buffalo Creek Disaster, 1972, p. 18), and the postfailure field evidence does not wholly confirm or refute the presence of this spillway. The preponderance of available records and testimony indicates that the spillway was, in fact, present, and we assume it was present for purpose of our analyses.

Throughout the remainder of 1971, and up to the time of the February 26, 1972, failure, dumping continued on Dam No. 3. Trucks dumped primarily at the top of the upstream face, but also along the downstream face. A high altitude aerial photograph of the site was taken November 3, 1971, by the Appalachian Regional Commission, and has been published by Davies and others (1972b) as their Figure 6. This photograph shows (in a print furnished to us by Davies) four small surficial slides on the downstream face of Dam No. 3 and a probable slide of small extent on the upstream face. The presence of these slides indicates, most likely, that the faces of the dam were locally oversteepened.

Figure V-14H shows the dam as it probably appeared a few days before the failure. As shown on this figure, the water level in Pool 3 is at about 1,740-1,745 feet. Due to the winter rains, this is a few feet higher than the long-term pool level. Piles of dumped refuse line the entire back portion of the crest "10 deep" as reported, and a few piles are scattered along the front face at the left.

Throughout 1971, boils of black water occasionally appeared in Pool 2 near the left portion of the downstream toe of Dam No. 3. These boils were evidence of piping and constituted a danger signal. Apparently, no one who observed the boils was aware of their significance. The possible role of piping in the failure of Dam No. 3 is discussed in Chapter VII.

Dam No. 4 was started in late 1968 and completed early in 1969, while Dam No. 3 was still an embankment extending part way across Middle Fork Valley some 2,600 feet downstream of Dam No. 4. Figure III-3C shows Dam No. 4; the map relations and aerial photographs suggest that Dam No. 4 was constructed by bulldozing part of the small refuse bank to the right of the dam into the valley below. Pool 4 had a low capacity (15 acre-feet) and rapidly filled with sludge and silt. For the few months it was effective, Dam No. 4 kept additional sludge and silt from entering Pool 2.

67 79

Dam No. 4 did not fail in February 1972; the flow of Middle Fork, including the output of the sludge discharge line, went over its spillway and into Pool 3. Figures V-15A and B show the spillway and the slumping of the downstream face. The slumping has reduced the crest width, and failure by progressive slumping upstream to the pond and consequent breaching is probable in time unless maintenance is done. However, the consequences of a failure of Dam No. 4 are considered small at this time due to the fact that Pool 4 is completely filled with sludge and silt. Some downstream pollution with sludge and silt from Pool 4 would occur if Dam No. 4 failed.

In the period 1968-1972 the refuse bank was not receiving refuse full time. The construction of Dam No. 3 took most, if not all, of the solid refuse output of the No. 5 Preparation Plant. Occasionally Dam No. 3 was inaccessible to the refuse trucks by reason of bad weather or road repairs, or the trucks could not travel on the embankment surface because it was too soft or crowded with dumped piles. At these times the trucks dumped on the refuse bank or filled in the left portion of Pool 1 by dumping on the refuse bank, or on the left side of the downstream face of Dam No. 2.

The history of the construction of the Middle Fork refuse bank and dams is condensed in Table V-1. Figure C-3 shows their history in calendar-graphic form. Table V-1 records four major pre-1972 failures: one each of Dam No. 1 and Dam No. 2, and two of Dam No. 3. In addition, minor slumping has occurred on the downstream face of Dam No. 4. Thus, all the dams in Middle Fork Valley have a history of failures.



PHOTO A. DAM NO. 4, DOWNSTREAM FACE.
SPILLWAY IS IN BEDROCK.



PHOTO B. DAM NO. 4, CREST AND DOWN-
STREAM FACE. NOTE SLUMPING ON
FACE.

NOTE: LOCATIONS OF PHOTOS ON THIS SHEET ARE
SHOWN ON FIGURE III-3C.



PHOTO C. SLUDGE AT UPPER END OF
POOL 3. STAKES (ARROWS) ARE
LOCATIONS OF VANE SHEAR AND CONE
PENETROMETER TESTS. TOP OF SLUDGE
HERE COINCIDES WITH THE DEAD TREE
LINE AT ABOUT ELEVATION 1735.



PHOTO D. UPPER END OF POOL 3, LOOKING
DOWNSTREAM. THE BASES OF THE LOWER-
MOST LIVE TREES ARE AT ELEVATION 1735;
THE SLUDGE IN THE MIDDLEGROUND IS AT
ELEVATION 1714.

TABLE V-1
 CHRONOLOGICAL SUMMARY
 OF
 MIDDLE FORK COAL REFUSE BANK AND DAMS
 CONSTRUCTION, FAILURES, AND REPAIRS, 1947 TO FEBRUARY 1972

YEAR	MONTH	EVENT
1947	---	LORADO COAL MINING COMPANY COMPLETED PREPARATION PLANT AND STARTED DUMPING REFUSE AT MOUTH OF MIDDLE FORK VALLEY.
1960	MAY	DAM NO. 1 CONSTRUCTED: "ACROSS THE VALLEY AT A POINT UPSTREAM OF THE THEN-EXISTING REFUSE PILE " (PARK AND OTHERS, 1972).
1962	NOV. 28	AERIAL PHOTOGRAPHY; SEE FIGURE V-9
1962 OR 63	---	SAUNDERS REFUSE BANKS DESCRIBED BY STAHL (1964)
1963	NOV.	MINING OPERATIONS SHUT DOWN BY LORADO COAL MINING COMPANY
1964	OCT.	BUFFALO MINING COMPANY TOOK OVER; OPERATIONS RESUMED
1966	DEC. (?)	DAM NO. 2 CONSTRUCTION STARTED BY BUFFALO MINING COMPANY
1967	MAR.	DAM NO. 1 OVERTOPPED, FAILED, PRESUMABLY BY BREACHING, CAUSING EROSION OF INCOMPLETE DAM NO. 2 EMBANKMENT. DAMS REPAIRED BY TRUCK DUMPING FILL INTO FAILED AREAS.
1967	APR. - JUNE	DAM NO. 2 CLOSED, WIDENED, AND 30-INCH OVERFLOW PIPE INSTALLED
1967	DEC.	DAM NO. 2 "COMPLETE" ACCORDING TO COMMISSION REPORT. "COULD IMPOUND WATER TO A DEPTH OF 20 FEET OVER THE SLUDGE DEPOSITS OF POOL 1."
1968	FEB. 26	SITE CONFERENCE (SEE TEXT). DAM NO. 3 LOCATION SKETCHED BY DASOVICH.
1968	MAR. 28	"NOTICE TO COMPLY" (SEE TEXT) ORDERED CONSTRUCTION OF THIRD DAM
1968	---	DAM NO. 2 RAISED.
1968	MAY	WORK BEGUN ON DAM NO. 3
1969	FEB.	COMMISSION REPORT: "DURING THE CONSTRUCTION OF DAM NO. 3, A MAJOR PORTION OF THE REFUSE SANK AND DISPLACED SOME OF THE SLUDGE ON WHICH IT WAS BEING BUILT." THIS FAILURE IS DESCRIBED AS "THAT WHOLE END OF THAT DAM, 100 FEET OF IT, DISAPPEARED" (U.S. CONGRESS, 1972b, pp. 318). THIS DESCRIPTION APPARENTLY REFERS TO THE ACTIVE END OF THE DAM FACING THE LEFT SIDE OF MIDDLE FORK VALLEY, NOT AN UPSTREAM OR DOWNSTREAM FACE FAILING.

TABLE V-1 — CONTINUED
 CHRONOLOGICAL SUMMARY
 OF
 MIDDLE FORK COAL REFUSE BANK AND DAMS
 CONSTRUCTION, FAILURES, AND REPAIRS, 1947 TO FEBRUARY 1972

YEAR	MONTH	EVENT
1969	---	DAM NO. 4 CONSTRUCTED
1969-71	---	MINOR SLUMPS ON DOWNSTREAM FACE OF DAM NO. 4
1970	(EARLY)	DAM NO. 3 CLOSED — BLOCKS VALLEY AND POOL 3 IS FORMED
1970	JUNE	BUFFALO MINING COMPANY ACQUIRED BY THE PITTSBON COMPANY. PITTSBON ENGINEERS "SURVEYED" THE PROPERTY AND THEIR "REPORTS HAD NO INDICATION THAT THERE WAS ANY DANGER, OR THAT ANYTHING WAS WRONG WITH THE IMPOUNDMENTS." (AD HOC COMMISSION HEARINGS TRANSCRIPT, VOL. V, p.77). DAM NO. 3 ESTIMATED AT 50 PERCENT COMPLETE. (THIS PROBABLY REFERS TO VOLUME COMPLETION AS THE DAM WAS APPARENTLY CLOSED PRIOR TO JUNE 1970).
1971	FEB.	DAM NO. 3 NEAR ITS FINAL HEIGHT.
1971	---	BOILS OF BLACK WATER REPORTED TO BE INTERMITTENT IN POOL 2 IN THE DOWNSTREAM LEFT TOE AREA OF DAM NO. 3. (U.S. CONGRESS, 1972a, AND DAVIES AND OTHERS, 1972). BOILS PRESENT THROUGHOUT MOST OF 1971, ESPECIALLY WHEN POOL 2 WAS AT A LOW LEVEL.
1971	FEB.	DAM NO. 2 "CRACKED DOWN THE MIDDLE AND SLUMPED." REPAIRED BY DUMPING REFUSE INTO SLUMP AND WIDENING DAM ON UPSTREAM SIDE.
1971	FEB. OR MAR.	DOWNSTREAM SIDE OF LEFT ABUTMENT OF DAM NO. 3 SLUMPED. SLUMP SIZE ESTIMATED TO BE "150 TO 200 FEET WIDE ACROSS THE FACE OF THE DAM AND 20 TO 30 FEET FROM FACE BACK." BLACK WATER OBSERVED BOILING INTO POOL 2 FROM THE DOWNSTREAM SIDE OF DAM NO. 3 AFTER FAILURE (COMMISSION REPORT). FROM PARK AND OTHERS (1972): "IN 1971 . . . A PORTION OF THE . . . DAM FAILED AT THE LOCATION JUST OFF CENTER TOWARD THE NORTHEAST SIDE OF THE DAM."
1971	APR. - JUNE	"24-INCH EMERGENCY SPILLWAY" PLACED IN DAM NO. 3. PIPE WAS "PLACED DIAGONALLY ACROSS THE RIGHT SIDE OF DAM NO. 3 AND ABOUT 7 OR 8 FEET BELOW THE GRADED CREST." (COMMISSION REPORT).
1972	FEB. 26 8:00 A.M.	DAM NO. 3 FAILS CATASTROPHICALLY.

83

D. PREFAILURE CONDITIONS

1. General

The appearance of the refuse bank and Dams 1, 2, and 3 in early 1972 is seen on Figure V-16, in which postfailure topographic mapping was modified to show generalized prefailure topography, according to the available descriptions of the dams. Figure V-17 is a section generally along the center of Middle Fork Valley, and shows the profile of the dams and refuse bank before failure. Large-scale, more detailed versions of these drawings were used in our engineering analysis. Another interpretation of the prefailure appearance of the valley is shown on Figure V-18, where the prefailure outlines of the dams and pools have been sketched on a postfailure aerial photograph. Figure V-19 is a diagrammatic sketch of Middle Fork Valley before the failure.

2. Refuse Bank and Dam No. 1

In February 1972, the refuse bank or old gob pile extended more than 2,100 feet up Middle Fork Valley. It filled the valley to a maximum width of 400 feet, and its highest points were over 220 feet above the elevation of Buffalo Creek at Saunders. Dam No. 1 was a dike on the right side of the valley; it was about 100 feet long, and perhaps 6 to 8 feet high on its downstream face and 15 to 20 feet wide on its crest. A utility pole and shop building were located southwest of Dam No. 1 (Figure V-19). Two 24-inch pipes in Dam No. 1 were embedded near the right abutment. They discharged water from Pool 1, passing under the road to the No. 5 Mine, to a diversion ditch on the right side of the road. The prefailure volume of the refuse bank is estimated at 3,000,000 cubic yards.

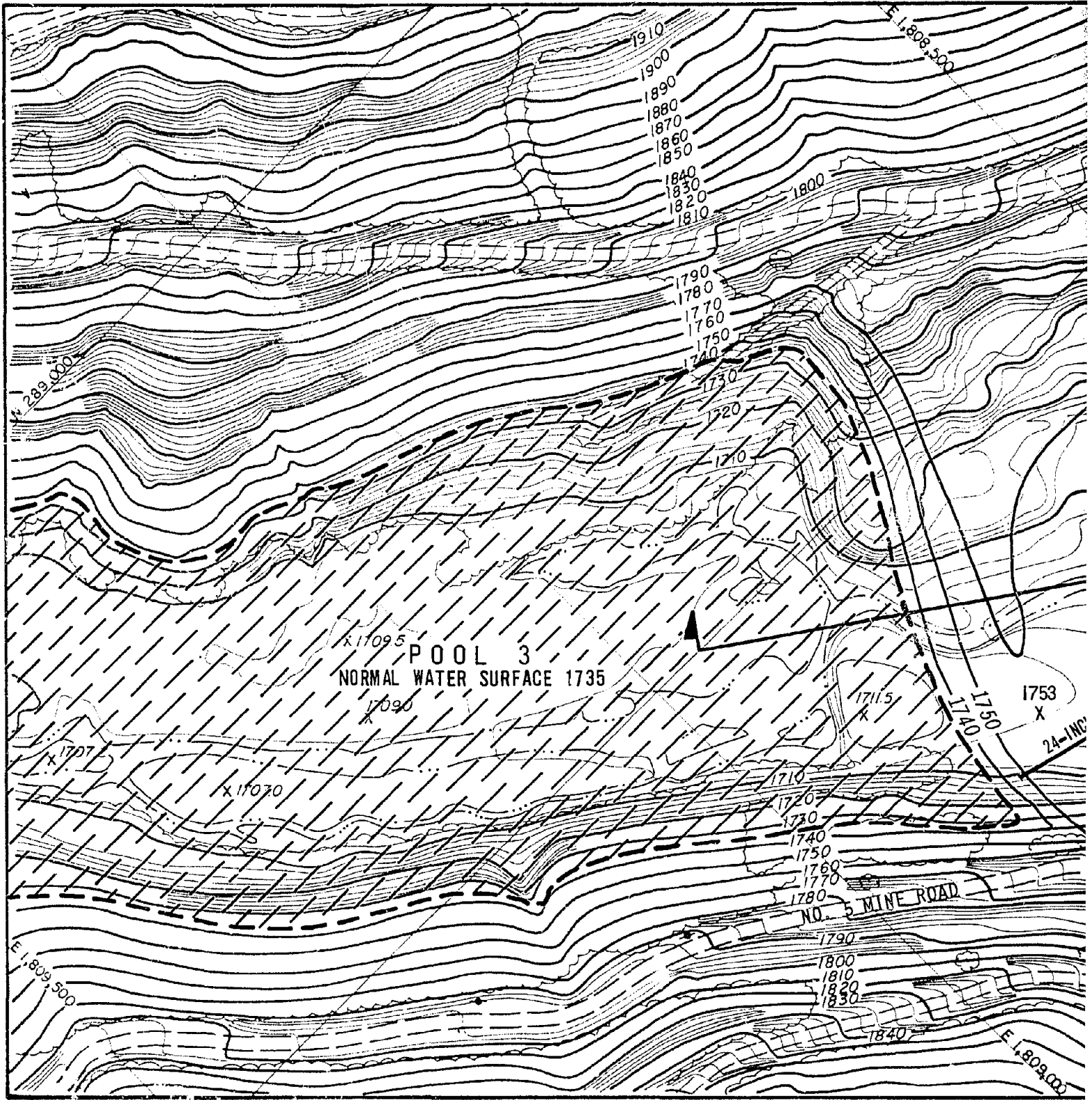

BASE MAP BY MICHAEL BAKER, JR., INC. COMPILED FROM AERIAL PHOTOS FLOWN ON 4/9/72.



CONSTRUCTED PREFAILURE CONTOURS SHOWN IN HEAVY LINES, POST-FAILURE CONTOURS ARE LIGHT LINES.

FOUR FOOT INTERVAL ON RECONSTRUCTED CONTOURS IS 10 FEET; SELECTED UNRECONSTRUCTED CONTOURS ARE ALSO SHOWN.

FAILURE TOPOGRAPHY RECONSTRUCTED ON THE BASIS OF DESCRIPTIONS AND TESTIMONY IN SEVERAL PUBLICATIONS LISTED IN CHAPTER IX.

(4) DATA IN THE TEXT SUCH AS VOLUMES AND SIZES OF POOLS, DIMENSIONS AND SLOPES OF EMBANKMENTS, ETC., WERE DERIVED FROM LARGE-SCALE PHOTOGRAPHIC DRAWINGS AND MAY NOT BE PRECISELY DUPLICATED BY SIMILAR DATA DERIVED FROM THIS GENERALIZED MAP.

(5) X 1753 = SPOT ELEVATION ON LOWEST POINT ON CREST OF DAM NO. 3 (SEE TEXT).

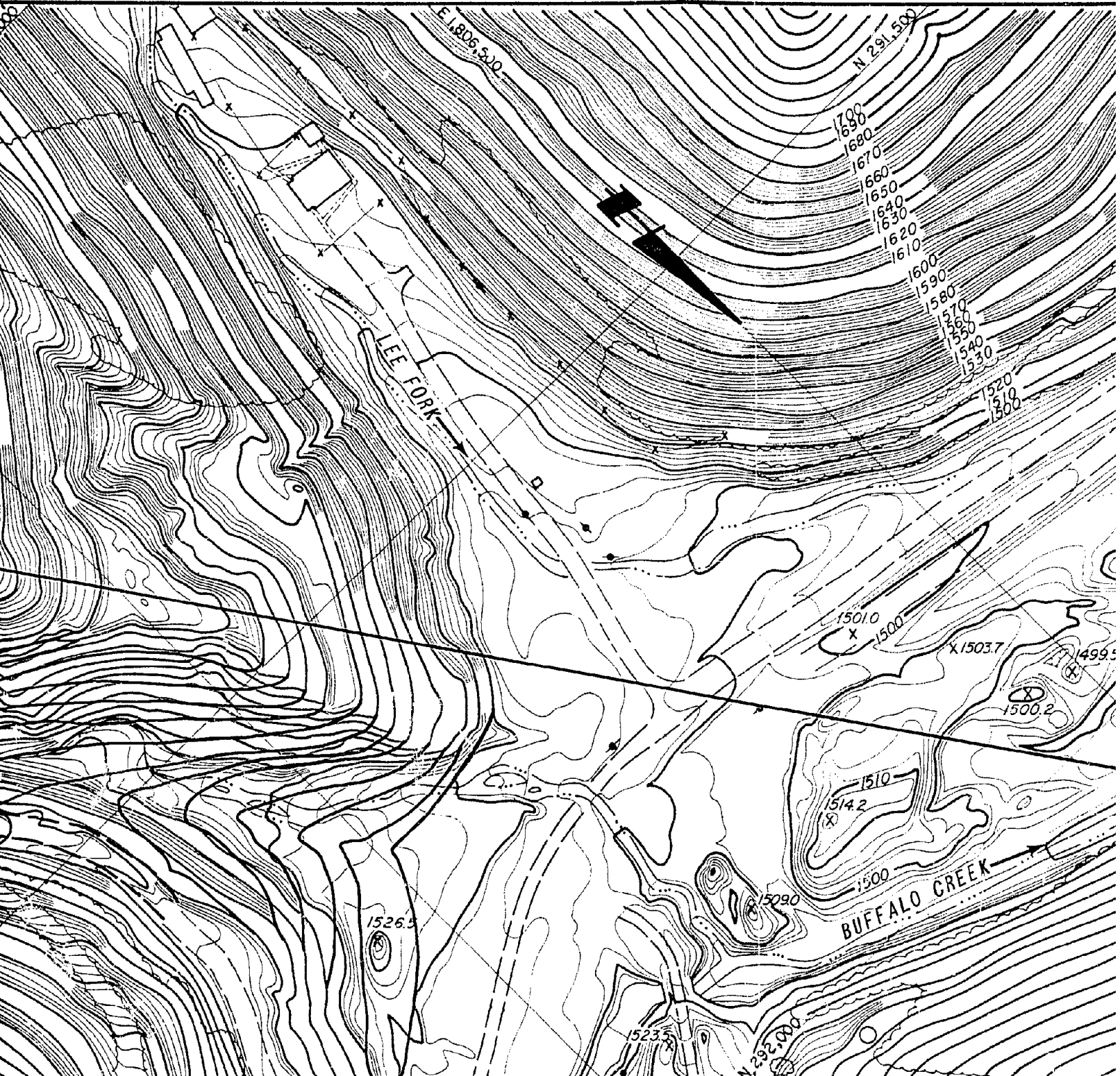

SCALE



MAIN CONTOUR INTERVAL 10 FEET

W. A. WAHLER & ASSOCIATES	COAL REFUSE DAM FAILURE SAUNDERS, WEST VIRGINIA	GEN
		PROJ
PALO ALTO • NEWPORT BEACH • CALIF.		07

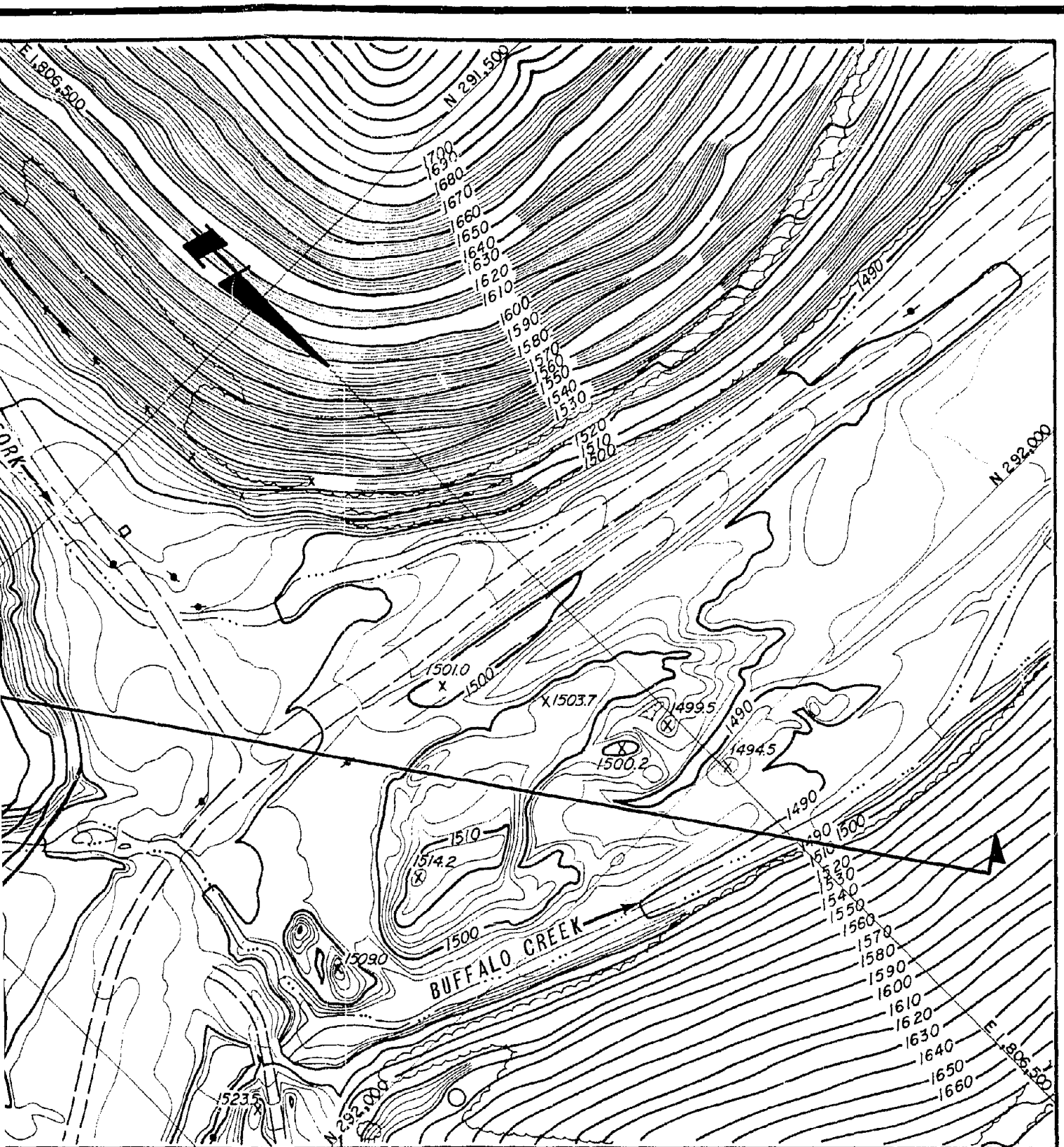

W.A. WAHLER & ASSOCIATES	COAL REFUSE DAM FAILURE SAUNDERS, WEST VIRGINIA		GENERALIZED PREFAILURE TOPOGRAPHY MIDDLE FORK VALLEY, EARLY 1972	
	PALO ALTO • NEWPORT BEACH • CALIF.	PROJECT NO 0700	DATE NOVEMBER 1972	FIGURE NO. V-16

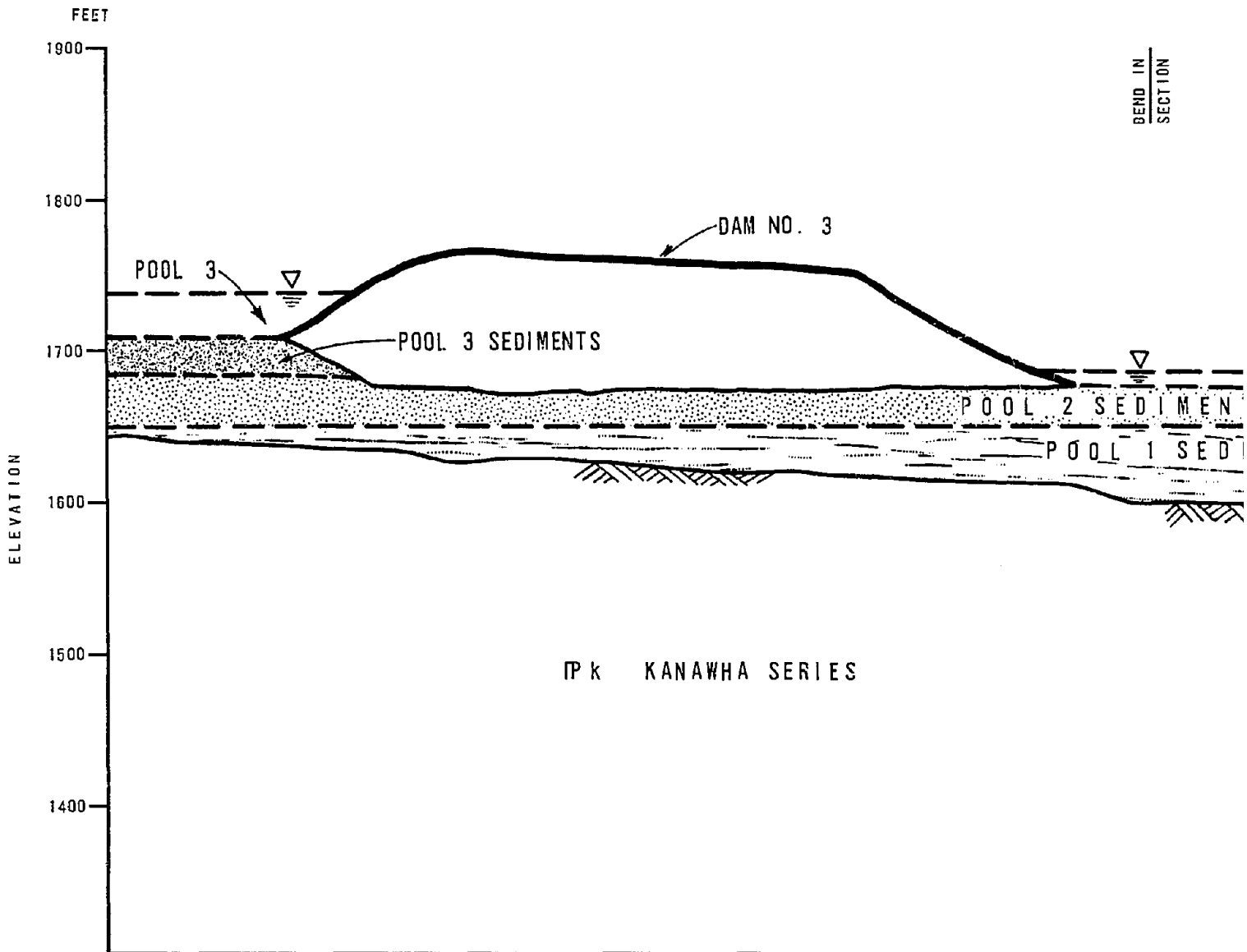

NOTES: (1) PATTERNS USED FOR THE SLUDGE OF POOLS 1, 2, AND 3 ARE FOR DELINEATION ONLY AND ARE NOT MEANT TO SUGGEST TEXTURE OR COMPOSITION.
 (2) FOR LOCATION OF SECTION SEE FIGURE NO. V-16.

BEND IN
SECTION

BEND IN
SECTION

BEND IN
SECTION

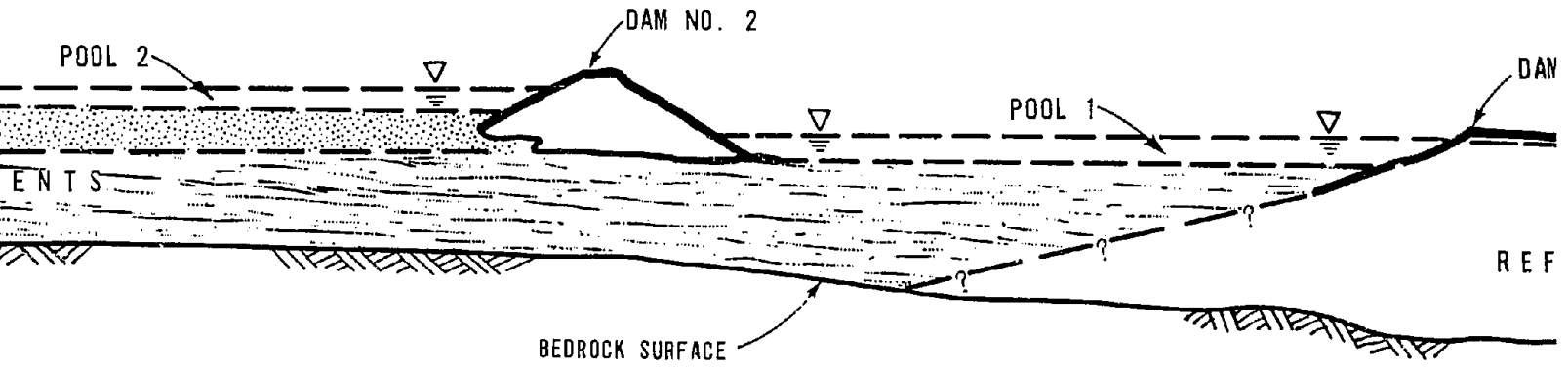

SECTION

BEND IN
SECTION

BEND IN
SECTION

DAM NO. 1 DIKE

R E

PROFILE OF MIDDLE FORK PROJECTED TO LINE OF SECT

REFUSE BANK

IPK KANAWHA SERIES

CROSS SECTION

SECTION

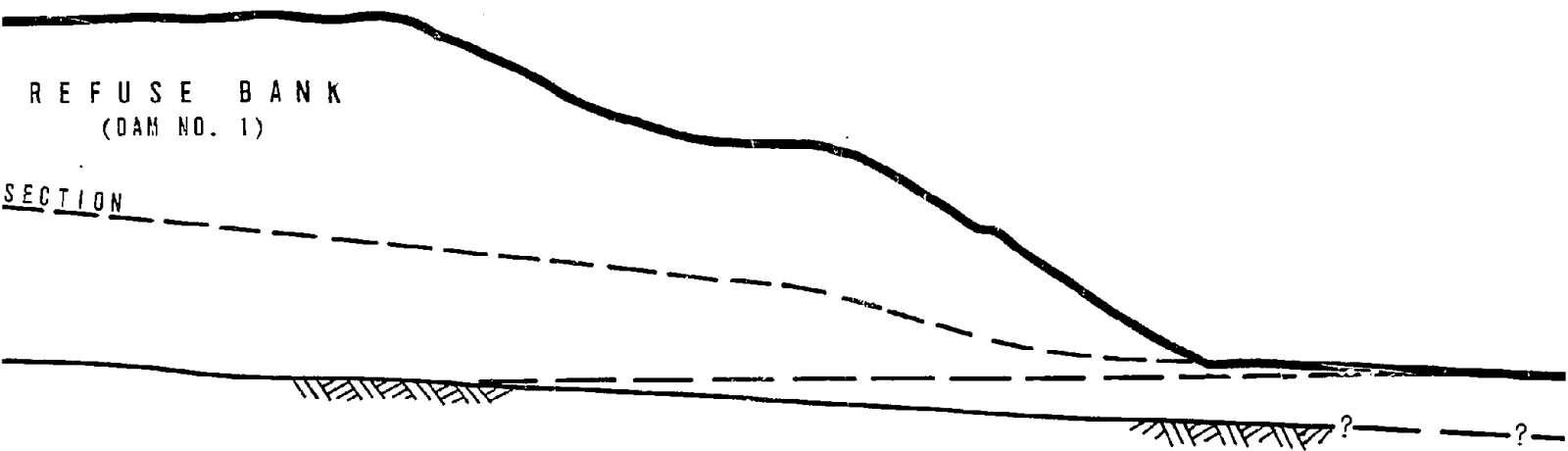

REFUSE BANK
(DAM NO. 1)

SECTION

TP k KANAWHA SERIES

W. A. WAHLER
& ASSOCIATES

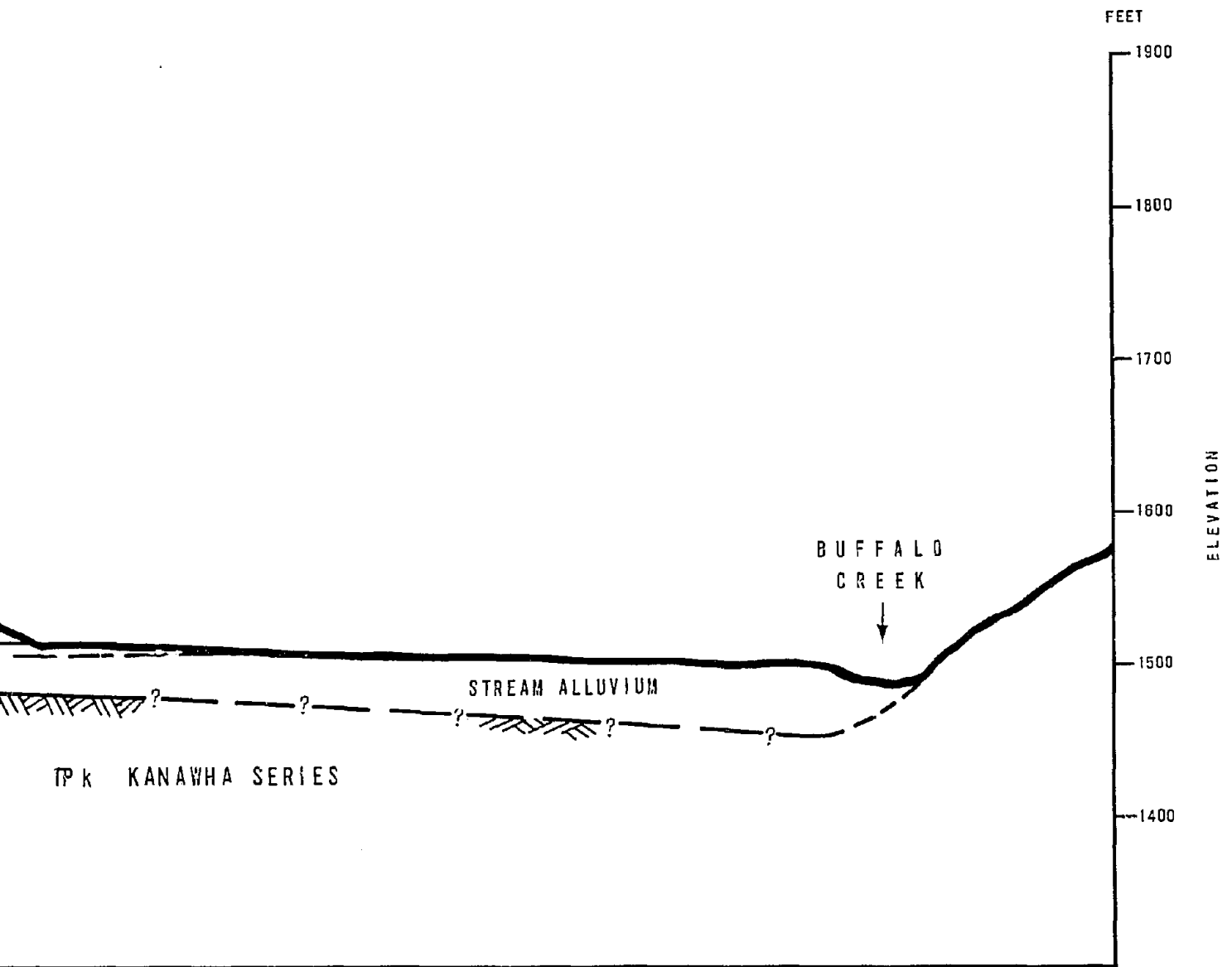

SCALE



HORIZONTAL = VERTICAL

86

W.A. WAHLER & ASSOCIATES	COAL REFUSE DAM FAILURE SAUNDERS, WEST VIRGINIA	PREFAILURE CROSS SECTION MIDDLE FORK VALLEY, EARLY 1972		
		PROJECT NO	DATE	FIGURE NO
PALO ALTO • NEWPORT BEACH • CALIF.	0700	NOVEMBER 1972	V-17	

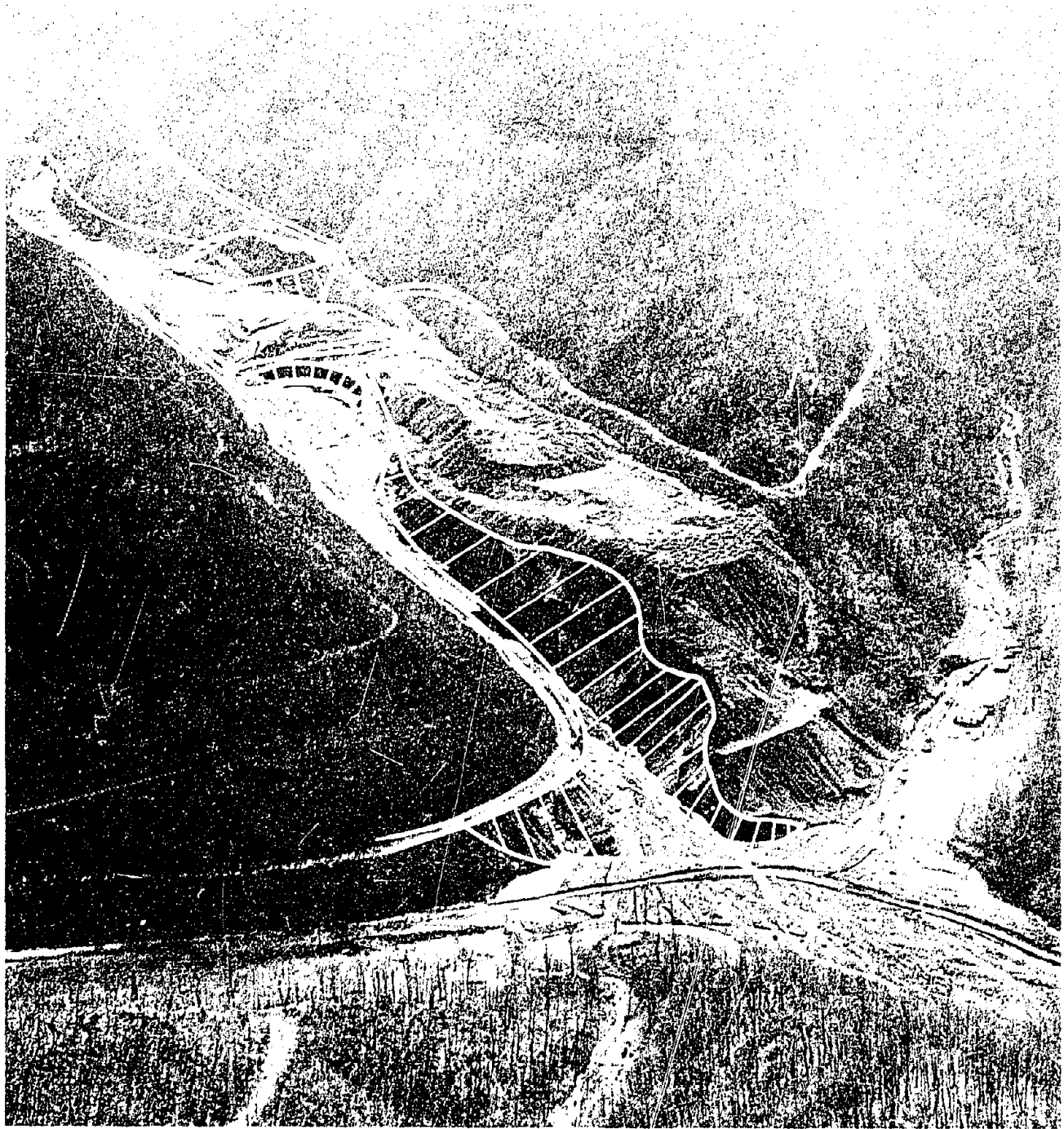

AERIAL VIEW OF MIDDLE FORK VALLEY, FEBRUARY 28, 1972, LOOKING UPSTREAM. THE PREFAILURE CONFIGURATION OF REFUSE BANK AND DAMS 1, 2, AND 3, HAS BEEN ADDED. PHOTO COURTESY, WEST VIRGINIA DEPARTMENT OF HIGHWAYS.



W. A. WAHLER
& ASSOCIATES

MIDDLE FORK VALLEY IN EARLY 1972

3. Dam No. 2

In February 1972, Dam No. 2 was 450 feet wide across the valley, but the left half was essentially part of the refuse bank, and the right half was an embankment separating Pools 1 and 2. The minimum crest elevation of Dam No. 2 was about 1,690 feet; the minimum crest width on the right side was probably about 25 feet near the right abutment (Figure V-16). A 30-inch diameter overflow pipe was in place near the right abutment. The pipe discharged into the ditch on the right side of the No. 5 Mine Road below the right abutment of Dam No. 2. We estimate the upstream invert of this pipe to have been approximately at Elevation 1,685 (i.e., about 5 feet below the lowest portion of the crest). The dam, just prior to failure, was a complex structure, especially on the right abutment side as a result of the previous failure and repairs. The volume of the Dam No. 2 embankment is estimated at 88,000 cubic yards.

4. Dam No. 3

By February 1972, Dam No. 3 probably appeared as shown on Figures V-16, 17, 18, and 19. By far the largest of all the Middle Fork dams, Dam No. 3 was nearly 600 feet wide at its maximum across Middle Fork Valley. The volume of the embankment is estimated at 534,000 cubic yards. The crest of its downstream face, which was about 450 feet long, sloped downward from left to right and varied in elevation from 1,760 feet at the left abutment to 1,740 feet at the right abutment. The crest of its upstream face was about 465 feet long and varied in elevation from 1,765 feet at the left abutment to about 1,752 feet at a low point near the right abutment. The previous dimensions reflect the crests of the upstream and downstream faces of Dam No. 3. The crest of the dam itself, connecting points of highest elevation from left abutment to right abutment, had a minimum elevation of 1,753 as shown on Figure V-16. This, then, is the point at which

water would first overtop the dam if the Pool 3 elevation was higher than 1,753 feet.

Because of the irregular construction techniques, the upstream and downstream faces were not uniform. The upstream face sloped at about 25° to 30° and had roughly the shape of an elongated reversed "S"; there was a fairly deep re-entrant at the upstream right abutment. The downstream face was slightly concave. On the left side, the downstream face had a fairly uniform slope inclined at 37° to 39° . However, on the right side it probably broadened into a variable slope. Locally, the slopes were oversteepened and probably stood as steeply as 45° for short times.

Long-term pool elevations of 1,685 for Pool 2 and 1,735 for Pool 3 probably prevailed for much of 1971. During the weeks just prior to failure, it is probable that Pool 3 rose to a surface elevation in the range of 1,740-1,745 feet due to winter rains. The control on the elevation of Pool 2 was the 30-inch outlet pipe near the right abutment of Dam No. 2, which had its upstream invert at Elevation 1,685. It is assumed that seepage from Dam No. 3 was sufficient to keep Pool 2 continuously full to at least this level during the wet season. Evidence for a long-term elevation of 1,735 for Pool 3 is a water line on the reservoir walls at that elevation, and the fact that all trees below that elevation are dead, presumably killed by nearly continuous submersion in the pool (Figure V-15, Photos C and D). A 24-inch diameter "overflow pipe" or "emergency spillway" was reportedly installed in Dam No. 3 about June 1971, at a depth of 7-8 feet below the then-existing surface. It is shown on Figures V-16 and V-19, but its location and elevation are not known within close tolerances.

During the weeks preceding the failure, trucks reportedly dumped coal refuse not only along the upstream edge of the crest of Dam No. 3, but also along the left portion of the downstream edge of the crest. Most of these piles were still present on February 25-26 (Figure V-14H and V-19).

E. RESERVOIRS

The reservoirs or pools created by Dams 1 through 4 are known as Pools 1 through 4, respectively. Pools 1 and 2 originally had fairly large areas, but the areas of these pools were considerably reduced by the subsequent construction of Dams 2 and 3, respectively. Our restoration of the prefailure topography of Middle Fork Valley (Figure V-16) is based on the large scale maps used in deriving the data presented in this section. A summary of pool data is presented in Table V-2.

Pool 1 in the days before failure acted as a "clear pool" of relatively sludge-free water which was recycled through the preparation plant as needed. Its shape in outline was that of a rectangle beveled at one corner, about 380 feet long and 130 feet wide. Its maximum water depth was about 24 feet, with a water surface elevation of 1,654 feet. Water entered Pool 1 by seepage through Dam No. 2, and left Pool 1 by means of two 24-inch culverts which passed northerly near the right abutment of Dam No. 1, under the No. 5 Mine Road, and discharged into a ditch along the right side of the road. The upstream invert elevations of these culverts are estimated at 1,654 feet. The free water capacity of Pool 1 was approximately 12.6 acre-feet. Pool 1 impounded about 150,000 cubic yards of sludge before Dam No. 2 was built.

Before the failure, Pool 2 was roughly rectangular in outline. It was about 410 feet long and 280 feet wide. It may have been as shallow as 10 feet. Water entered Pool 2 by seepage through or under Dam No. 3, and left by seepage through or under Dam No. 2, or through the outlet pipe. A 30-inch diameter outlet pipe extended through Dam No. 2 near its right abutment, and under the No. 5 Mine Road to a ditch on the right side of the road. The upstream invert elevation of this pipe is estimated at 1,685 feet. It is possible that the pipe was usually flowing partly full. With the parameters used, Pool 2 had a free water capacity of approximately 30.9 acre-feet. Pool 2 impounded about 434,000 cubic yards of sludge before Dams 3 and 4 were built.

TABLE V-2

**SUMMARY OF POOL DATA
MIDDLE FORK DAMS**

FEBRUARY 1972

POOL	SURFACE AREA ACRES	WATER LEVEL (ft. MSL)	DEPTH (NOTE 1)	CAPACITY AT GIVEN WATER LEVEL		
				ACRE-FEET	CUBIC FEET	GALLONS
1	1.03	1654	24	12.6	550,000	4,110,000
2	3.45	1685	10	30.9	1,350,000	10,100,000
3	9.63	1735	25	184.0	8,010,000	59,900,000
	13.15	1753	45	392.0	17,100,000	128,000,000
4	1.34	(NOTE 2)	0	0	0	0

- NOTES:
1. DEPTH GIVEN IS ESTIMATED MAXIMUM DEPTH EXCEPT FOR THE 25 FOOT DEPTH FIGURE FOR POOL 3, WHICH IS ITS MAXIMUM DEPTH AT ITS TYPICAL LONG TERM WATER LEVEL.
 2. POOL 4 IS COMPLETELY FILLED WITH SLUDGE AND HAS NO SIGNIFICANT STORAGE CAPACITY. AT THE TIME DAM NO. 4 WAS BUILT, THE INITIAL CAPACITY OF POOL 4 WAS ABOUT 15 ACRE-FEET.
 3. DIRECT CONVERSION FROM ONE CAPACITY UNIT TO ANOTHER FOR A GIVEN POOL IS NOT EXACT DUE TO ROUNDING.

Pool 3, prior to the failure, was by far the largest of the pools. At its typical long-term water surface elevation of 1,735 feet, the free water capacity was 183.9 acre-feet or 14.6 and 6.0 times greater than the capacities of Pools 1 and 2, respectively. At its maximum water surface elevation of 1,753 feet, Pool 3 had a capacity of 392 acre-feet. The shape of Pool 3 was that of an elongated triangle. It was 370 feet wide at Dam No. 3 and about 1,600 feet long, and received drainage from about 654 acres upstream of Dam No. 3. In addition to natural runoff, the preparation plant of the Buffalo Mining Company discharged effluent through a 6-inch diameter pipeline into Middle Fork Valley. The discharge point was near the No. 5 Mine entrance in Middle Fork Valley, some 3,900 feet upstream from Dam No. 3. This effluent, amounting to 300,000 gallons a day, contributed about 200 tons per day of solids. Photos of the sludge deposits in the upstream end of Pool 3 are included on Figure V-15 (Photos C and D). Pool 3 contained about 223,000 cubic yards of sludge before the failure.

Water exited Pool 3 by seepage through or under Dam No. 3. The 24-inch spillway pipe was apparently installed above the long-term pool elevation that could be achieved by seepage through the dam. This pipe, when it did carry water, apparently discharged onto the downstream face of Dam No. 3, from which point the water would cascade down the face of the dam and enter Pool 2.

Pool 4, since it was upstream of the failure, was unaffected by it. Dam No. 4 was completed in 1969 and the pool filled with sludge and silt fairly rapidly. Within a few months, Pool 4 was completely filled with sediment and had virtually no water storage capacity. The surface of Pool 4 has an area of 1.34 acres, and the volume of sediment behind the dam is estimated to be 24,000 cubic yards. Dam No. 4 is relatively impervious; the discharge from Pool 4 is largely confined to the open-channel spillway at the left abutment of Dam No. 4.

F. SPILLWAY PROVISIONS

None of the four dams in Middle Fork Valley was provided with adequate spillways. The spillways of Dams 1, 2, and 3 were not included in these dams through most of their construction period. Each dam had pipe spillways included at late stages. The spillway history of Dam No. 4 is uncertain. We believe it may have been originally constructed with no spillway, as were the other three dams, and that subsequent high water carved the existing spillway by overtopping Dam No. 4 at its left abutment (Figure V-15A and B). A summary of the spillway history of each of the Middle Fork dams is presented in Table V-3. The dams, as originally built, relied on internal leakage to restrict reservoir levels.

Insofar as we have been able to determine, in no case was a pipe spillway installed with collars or baffles to prevent concentrated flow or movement of fine waste along the outside of the pipe. The pipe materials used appeared to be whatever was convenient to obtain at the time. Apparently no analysis was made of the loads that might be imposed on the pipes from traffic or heightened embankments. Neither was any study made of the hydrology of the watershed to determine a realistic size, shape, and gradient of spillway for any of the four dams on the Middle Fork. The spillway pipe for Dam No. 3 apparently discharged on the downstream face of the dam; this is an unacceptable practice for earth dams. The discharge of the Dam No. 3 spillway could have had an adverse effect on the stability of the downstream slope, although the extent of the effect cannot be stated with certainty. A speculative interpretation of the postfailure spillway evidence is presented in Chapter VII.

TABLE V-3
 SPILLWAY HISTORY SUMMARY
 MIDDLE FORK DAMS, 1966 THROUGH 1971

DAM	SPILLWAY TYPE	SIZE	WHEN PLACED	APPROXIMATE INVERT ELEVATIONS		REMARKS
				UPSTREAM	DOWNSTREAM	
NO. 1	2 PIPES	24-INCH DIAMETER	AFTER 1966	1,654	1,651	DISCHARGED INTO DRAINAGE DITCH AT RIGHT OF NO. 5 MINE ROAD.
NO. 2	1 PIPE	30-INCH DIAMETER	EARLY 1967	1,685	1,680	DISCHARGED INTO DRAINAGE DITCH AT RIGHT OF NO. 5 MINE ROAD.
NO. 3	1 PIPE	24-INCH DIAMETER	APRIL-JUNE 1971	1,745	1,740	PROBABLY DISCHARGED ONTO DOWNSTREAM FACE.
NO. 4	OPEN CHANNEL, UNLINED.	APPROX. 6 FEET WIDE BY 1.5 FEET DEEP.	UNKNOWN	1,798	1,780	DISCHARGES ALONG LEFT GROIN. MOST OF CHANNEL IS IN BEDROCK.

CHAPTER VI

POSTFAILURE APPEARANCE OF SITE

A. INTRODUCTION

The following discussion is presented in two parts. The first is largely descriptive and utilizes many photographs; the second interprets the postfailure surface and subsurface conditions based on geologic mapping and subsurface exploration, and is an introduction to the detailed engineering analyses and interpretation of the failure which follow in Chapter VII. This presentation sequence was chosen to provide the reader with the clearest possible understanding of the mutually supportive nature of interpretations derived from both the field evidence and the engineering analyses.

B. DESCRIPTION OF SITE

The postfailure appearance of the site is best described with pictures and maps. One of the most interesting aspects of the appearance of Middle Fork Valley, which can be seen in many of the photographs included here, is that the site is generally free of flood deposits despite the fact that most of the valley floor was inundated. The only large alluvial flood deposits in Middle Fork Valley are gravels and sludge filling the Pool 1 area. Elsewhere in Middle Fork Valley, the effects of the flood were largely neutral, with neither significant erosion nor deposition occurring.

The postfailure appearance of Middle Fork Valley is discussed here starting from the mouth of the valley and going upstream. Many photographs show several features and are referred to in various parts

of this report. The reader is referred to the photographs in Chapter V which also show the appearance of site features. Most of the features described below can be found on the geologic maps, Figures III-3A, B, and C, and Figure VI-20. Figure A-1 (Appendix A) shows the map location and camera view angle of most of the site photographs used in this report.

The Frontispiece and Figure VI-1 both show the large notch cut in the refuse bank and the 250-foot long eroded section of haul road. Immediately above the notch, the haul road is in good condition and was driveable with no repairs, as shown in Figure VI-2. At Dam No. 1, further upstream, the only obvious remnants are the pedestal (Figure V-1) and a small portion at the right abutment (Figure VI-3). Figure VI-3 also shows the gravel fill typical of Pool 1, and a "raft" of sludge, probably from Pool 2. Several sludge rafts are shown in Pool 1 on Figure VI-20, and one was cut by a backhoe pit (Pit 11, Appendix A, Figure A-6). The sludge rafts represent coherent masses of sludge transported by the flood waters and deposited along with coarse waste. Presumably, these sludge rafts were detached from the main mass of Pool 2 sludge, which lies upstream and is shown on Figure VI-4. Some small sludge patches on the refuse bank at Elevation 1,702 (Figure VI-5) are believed to represent some of the highest Pool 2 sludge left by the flood. Since the estimated prefailure surface of Pool 2 sludge is about 1,675 feet, these patches were lifted over 25 feet from their prefailure position. Figure VI-5 also shows the breach in Dam No. 2. The breach is about 110 feet wide and 20 feet deep. A prominent high water line was left by the flood at Elevation 1,709 along the left sides of Middle Fork Valley and the refuse bank (Figure VI-6).

Looking directly upstream from the station wagon body shown on Figure VI-4, Figure VI-7 shows the road to Dam No. 3 disappearing below the mass of sludge which has moved downstream and over Dam No. 2. This contorted mass of sand- and silt-sized coal fines has been informally



AERIAL VIEW, MARCH 15, 1972, OF THE NOTCH CUT IN THE REFUSE BANK BY THE FLOODWATERS
DASHED LINE IS APPROXIMATE BOUNDARY BETWEEN REFUSE PLACED IN THE YEARS SHOWN



HAUL ROAD ON RIGHT SIDE OF MIDDLE FORK VALLEY, JUST ABOVE THE "NOTCH" ERODED IN THE REFUSE BANK
VIEW LOOKING DOWNSTREAM.



A "RAFT" OF SLUDGE IN THE FLOOD ALLUVIUM FILLING POOL I. A SMALL REMNANT OF DAM NO. 1 AT ITS RIGHT ABUTMENT IS INDICATED BY THE ARROW

210

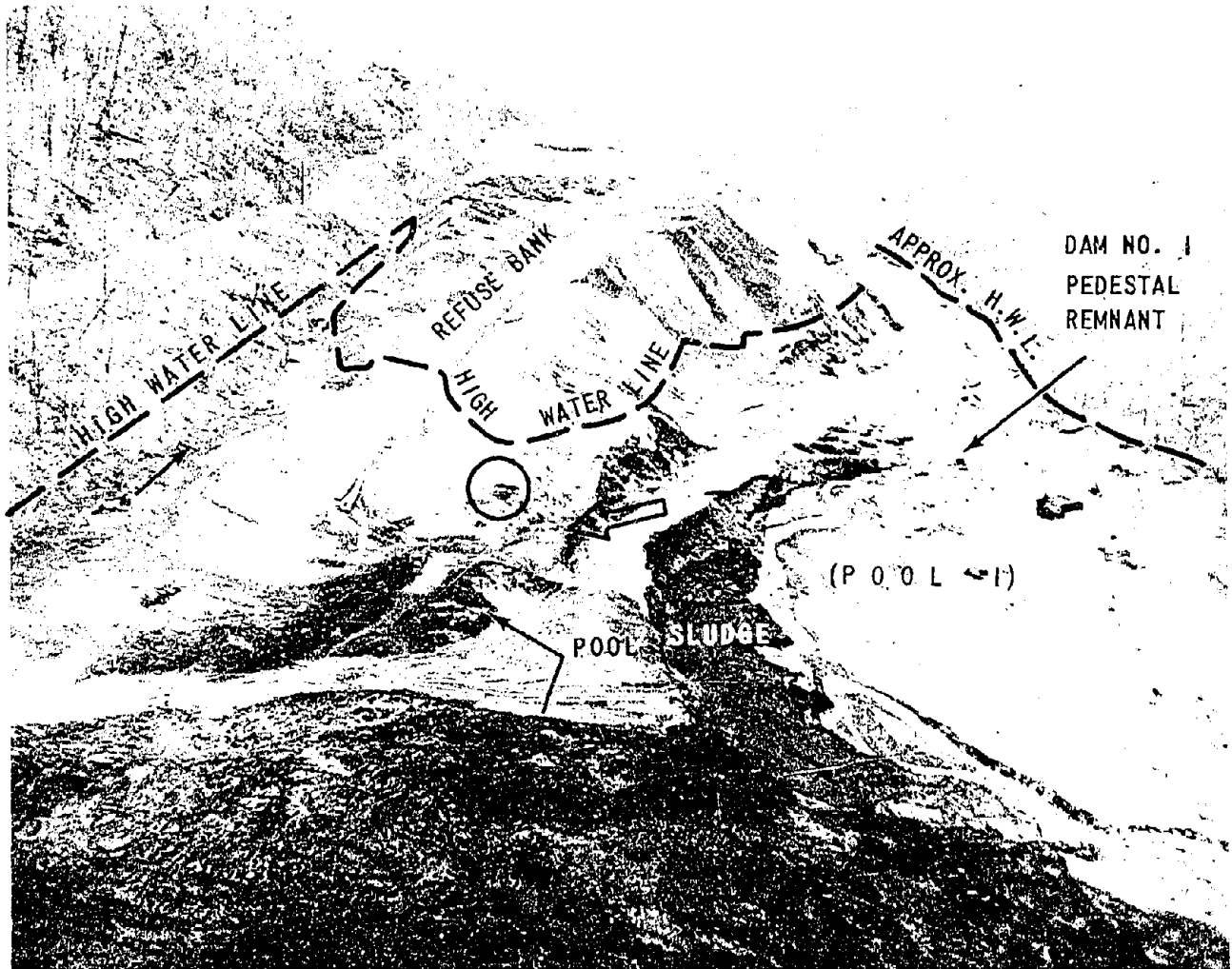

AERIAL VIEW OF MIDDLE FORK VALLEY, LOOKING DOWNSTREAM FROM ABOVE DAM NO. 2. THE TWO LENGTHS OF 24-INCH DIAMETER PIPE (LEFT OF THE STATION WAGON BODY) ARE THE ONES BUFFALO MINING COMPANY INTENDED TO INSTALL IN DAM NO. 3 AS A SUPPLEMENTAL SPILLWAY. THE DAM FAILED BEFORE THE PIPES COULD BE INSTALLED. THE APPROXIMATE HIGH WATER LINE FROM THE FLOOD IS SHOWN ON THE REFUSE BANK. PATCHES OF SLUDGE BELIEVED TO REPRESENT THE HIGHEST POOL 2 SLUDGE, AT ELEVATION 1702, ARE CIRCLED NEAR THE CENTER. THE MAIN MASS OF POOL 2 SLUDGE (BOTTOM OF PHOTO) WAS EMPLACED BY BEING PUSHED BY A MASSIVE SLIDE OF DAM NO. 3 EMBANKMENT INTO POOL 2. THE PATCHES PROBABLY WERE DETACHED FROM THE MAIN BODY OF SLUDGE AND EMPLACED BY THE FLOOD WATERS. FOR A CLOSE-UP VIEW OF THE HIGH WATER LINE, INDICATED BY THE SOLID ARROW, SEE FIGURE VI-6. THE ROAD HAS BEEN CLEARED OF SLUDGE; COMPARE THIS VIEW (TAKEN MARCH 15, 1972) WITH THE SOMEWHAT MORE EXTENSIVE SLUDGE DEPOSITS SHOWN IN FIGURE VI-19, TAKEN FEBRUARY 28, 1972. THE OPEN ARROW POINTS TO THE SMALL STREAM TERRACE SHOWN CLOSE-UP IN FIGURE VI-27C.

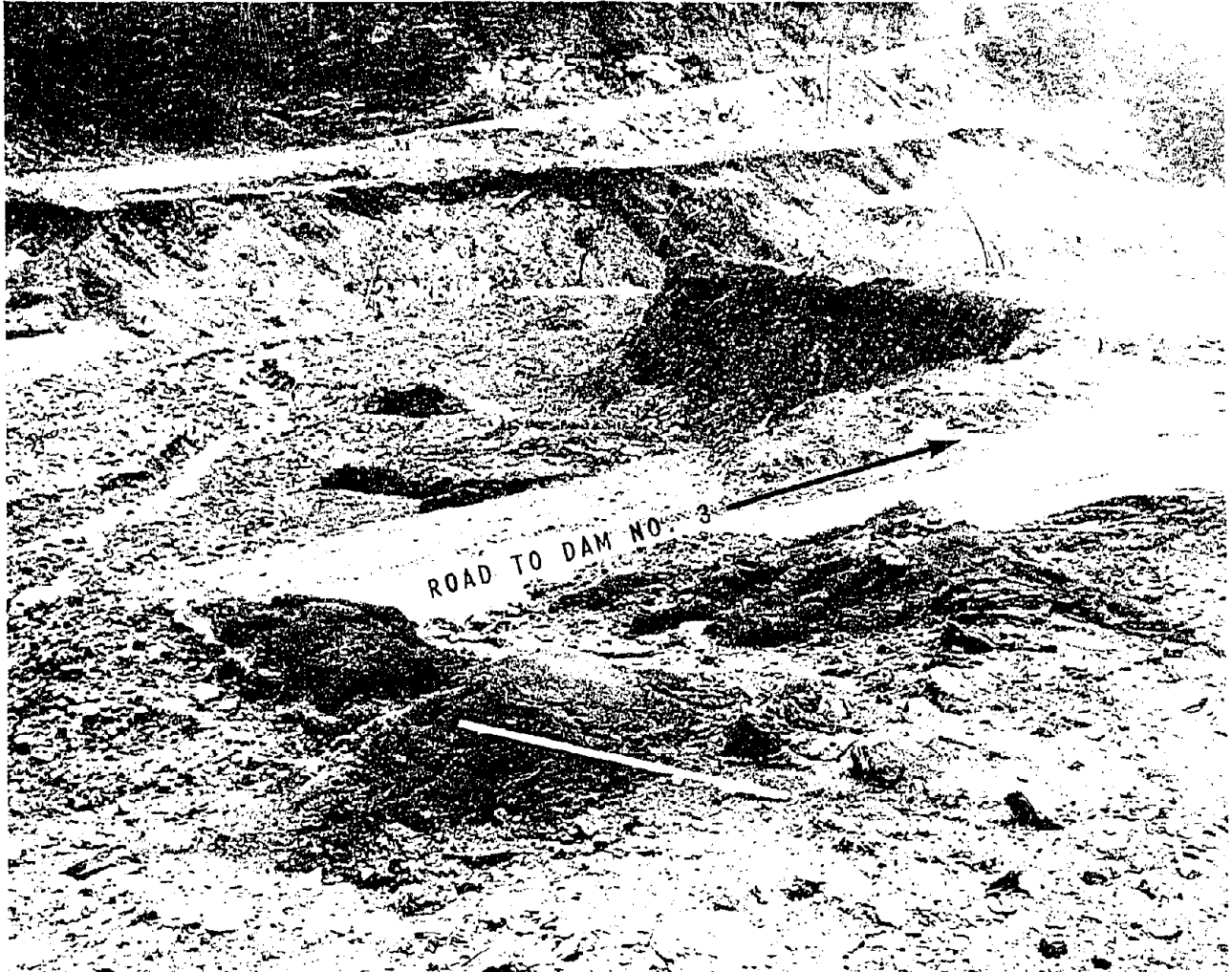

PATCHES OF POOL 2 SLUDGE AT APPROXIMATE ELEVATION 1702 ON REFUSE BANK (SEE ALSO FIGURE VI-4).



HIGH WATER LINE (ARROWS) AT APPROXIMATELY ELEVATION 1709 AT LEFT SIDE OF REFUSE BANK PHOTO
TAKEN ON FEBRUARY 29, 1973

2143



LEFT SIDE OF MIDDLE FORK VALLEY, LOOKING UPSTREAM FROM THE UPPER END OF THE REFUSE BANK. NOTE POOL 2 SLUDGE COVERING THE ROAD TO DAM NO. 3. PHOTO TAKEN FEBRUARY 29, 1972. THE THREE HIGHEST STREAM TERRACES CARVED IN DAM NO. 3 BY THE FLOODWATERS ARE INDICATED BY T-3, T-4, AND T-5. H.W.L. = HIGH WATER LINE FROM FLOOD

11-1

called "the roiled area" by many observers because of its similarity in appearance to a swiftly flowing turbulent stream. Figure VI-8 shows the roiled area (Pool 2 sludge) from the upstream side. Figures VI-9 through VI-12 show some of the structure and characteristics of the roiled area sludge, and its contact relationships with the translated mass of Dam No. 3 embankment upstream of it. The Pool 2 sludge in the roiled area is broken into a group of blocks, most of which are folded and tilted. The detectable outlines of the major blocks, and geologic mapping indicating the structure of the blocks, are shown on Figure VI-20. Figure VI-9 shows one of the major blocks. Gentle, broad folds in the roiled area are shown on Figure VI-10. The susceptibility of the sludge to erosion is illustrated on Figures VI-11 and VI-12, illustrating both surface and subsurface erosion.

The contact between Dam No. 3 translated embankment and Pool 2 sludge is shown on Figure VI-20. Examples of its outcrop are shown in photographs on Figures VI-13 and 14 and in the logs of many backhoe pits (Appendix A). On Figure VI-13, the contact dips downstream very steeply, and may be overturned. Generally, in other areas, the contact dips upstream or has some component of upstream dip (Figures VI-20 and A-6). Although the contact itself generally dips upstream, the sludge downstream of the contact generally dips downstream, as shown on Figure VI-14.

South of hole S-19 is an outcrop of great interest. It illustrates (Figure VI-15) local scour and subsequent deposition by the floodwaters and clearly shows coherent beds of mixed fine and coarse coal waste, interpreted to be a coherent mass of Dam No. 3 embankment. This section of embankment rests in the former Pool 2 area at an elevation several feet above the prefailure Pool 2 water surface level. The veneer of relatively coarse material deposited by the flood was present over nearly all the stream terraces cut into Dam No. 3 embankment remnants.

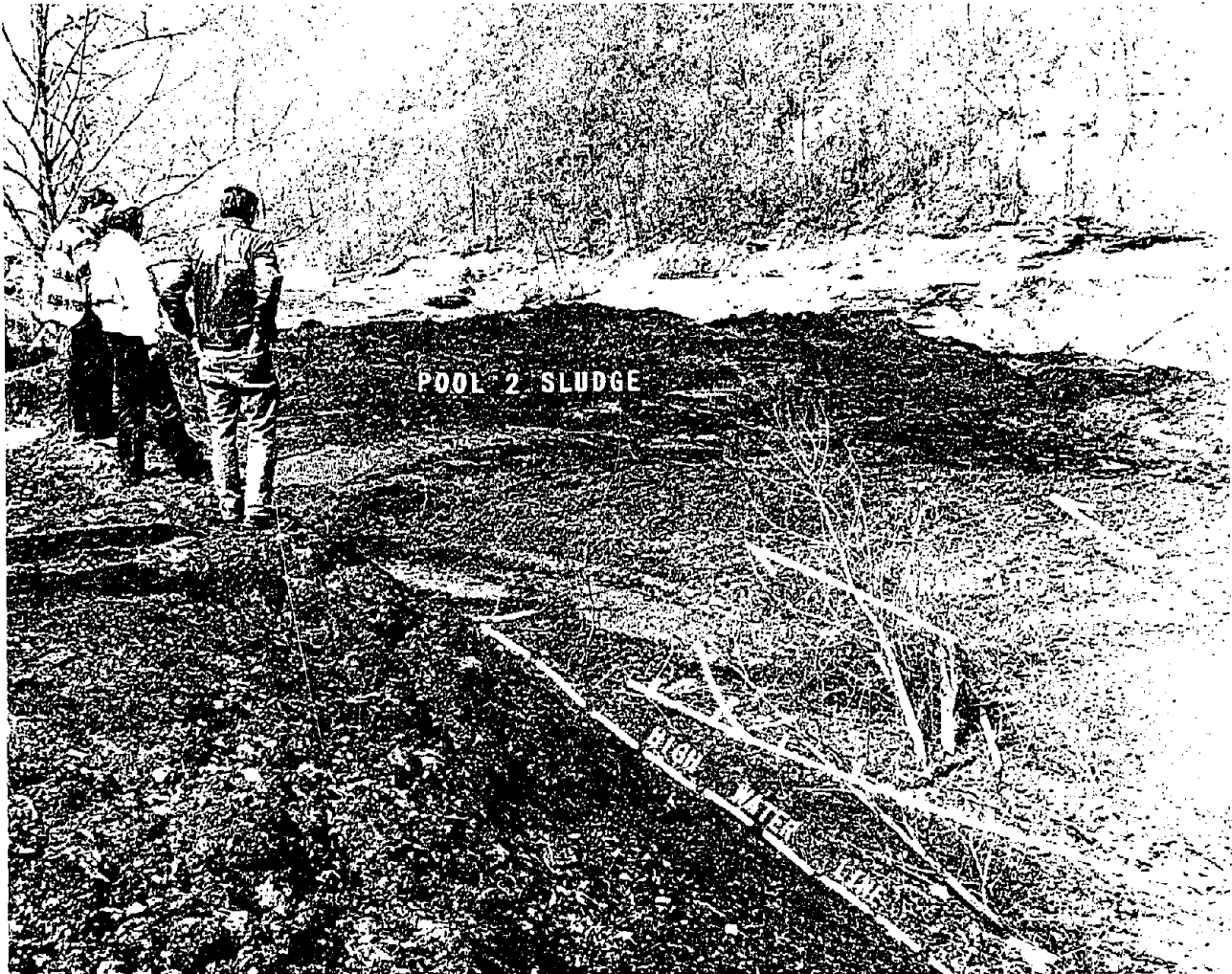

POOL 2 SLUDGE (DARK AREA IN MIDDLEGROUND) AND TRANSLATED DAM NO. 3 EMBANKMENT GRAVELS AT RIGHT, BELOW SLOPE. VIEW FROM ROAD ABOVE POOL 2 AT LEFT SIDE OF VALLEY. THE HIGH WATER LINE IS SHOWN HERE AT APPROXIMATE ELEVATION 1712. SYMBOLS SHOW LOCATIONS OF SECONDARY LANDSLIDE CRACKS IN TRANSLATED DAM NO. 3 EMBANKMENT GRAVEL. THE MAIN SLIDE MASS MOVED DOWNSTREAM (DIAGONALLY TO THE UPPER LEFT IN THE PHOTO), PUSHING THE DARK POOL 2 SLUDGE IN FRONT OF IT. HIGHER PORTIONS OF THE TRANSLATED EMBANKMENT ON THE LEFT SIDE OF POOL 2, JUST BELOW THE HIGH WATER LINE IN THE PHOTO, THEN SLID TOWARDS THE CENTER OF MIDDLE FORK VALLEY. FIGURES VI-9 THROUGH VI-14 WERE TAKEN IN THE POOL 2 SLUDGE OR "ROILED AREA", SHOWN ABOVE. FOR ANOTHER VIEW OF THE HIGH WATER LINE SHOWN HERE, SEE FIGURE VI-25A.



PORTION OF THE "ROLLED AREA" OF TRANSLATED POOL 2 SLUDGE. THE SMOOTH, FLAT AREA IS ONE OF THE MAJOR BLOCKS OF SLUDGE THAT WERE MOVED AS UNITS DURING THE FAILURE.

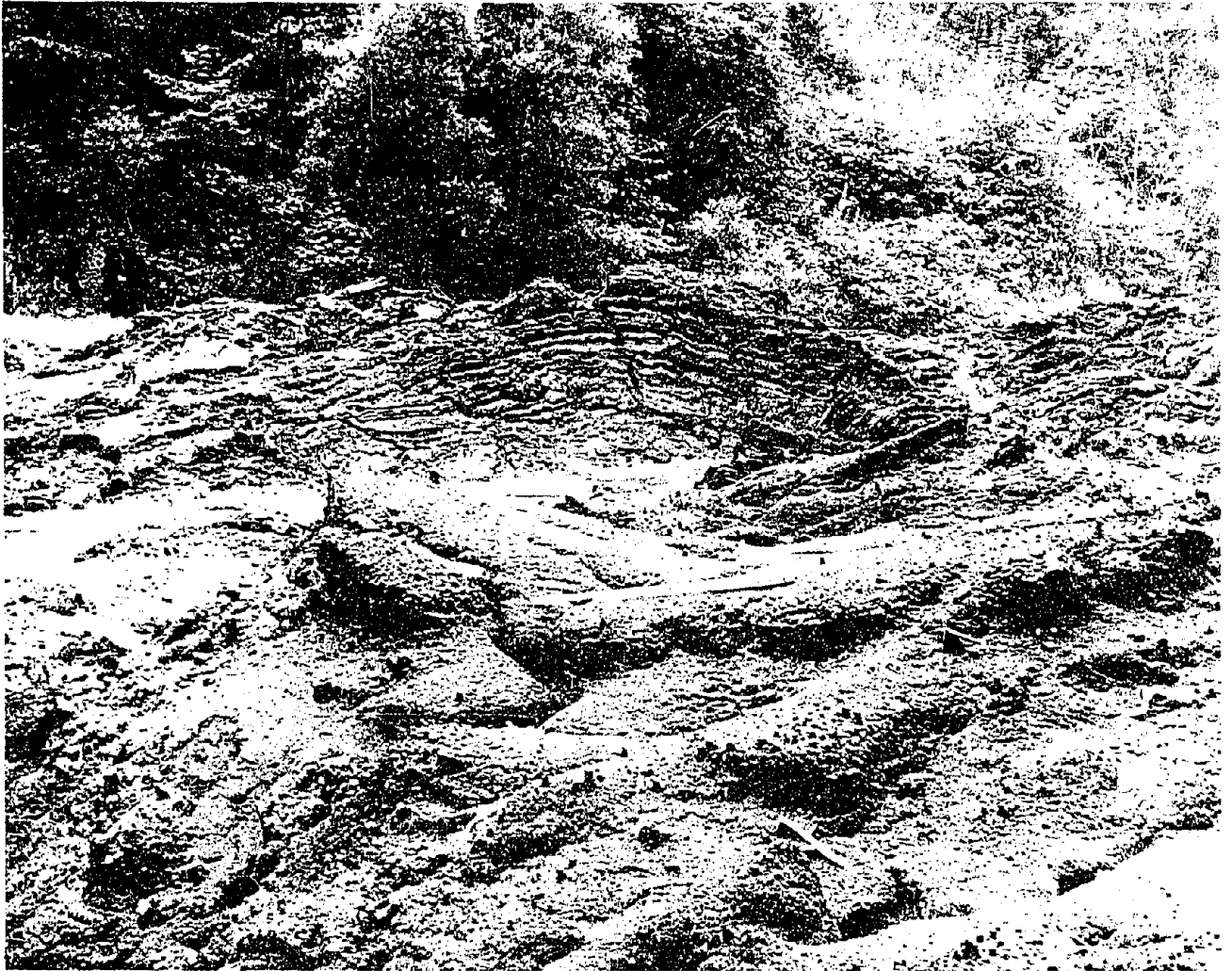

GENTLE FOLDS IN THE "ROILED AREA" OF POOL 2 SLUDGE. DETAILS OF THE BEDDING ARE WELL PRESERVED IN THE ANTICLINE IN THE BACKGROUND.

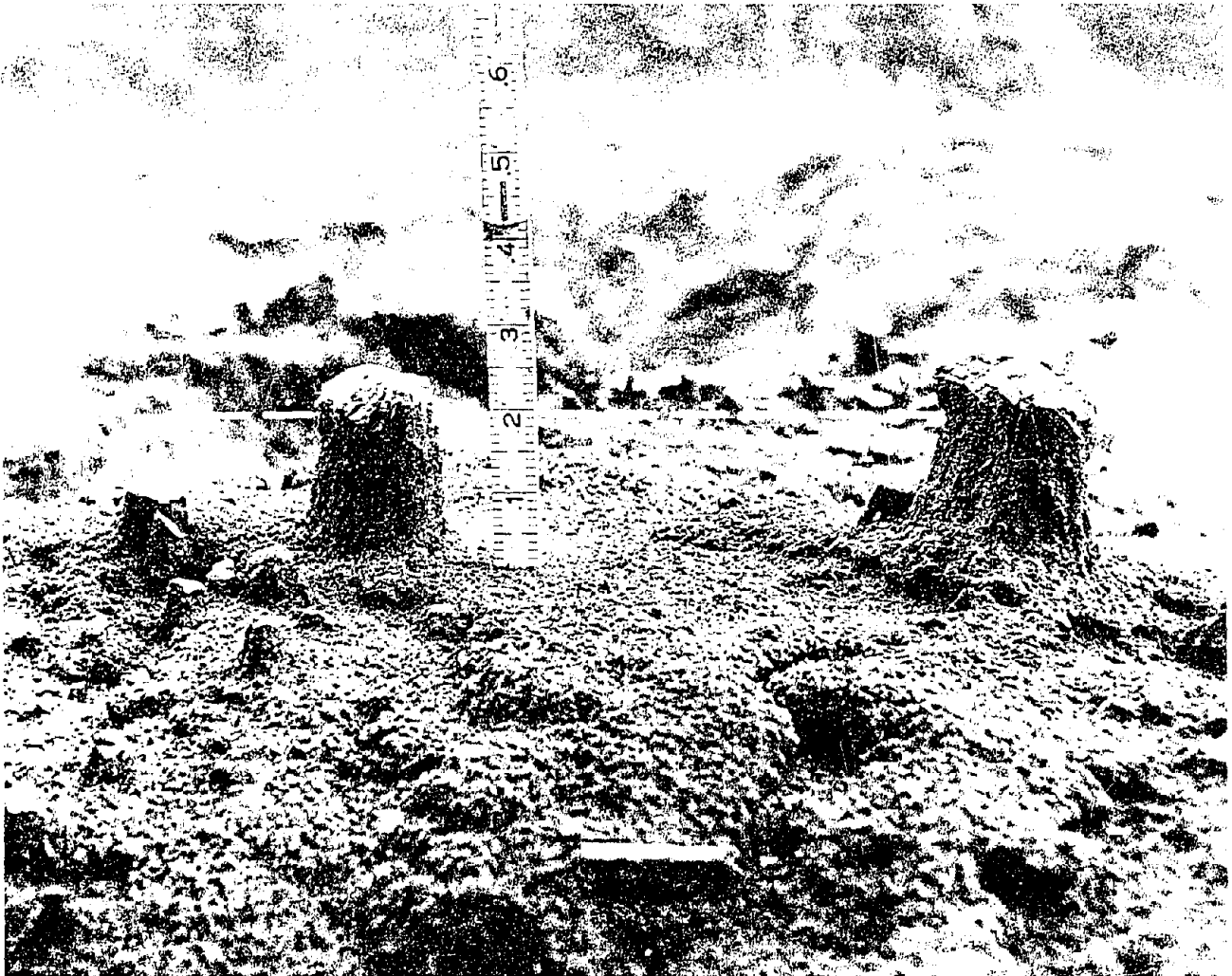

SMALL PEDESTALS IN THE POOL 2 SLUDGE. PHOTO TAKEN AUGUST 2, 1972. THE SURFACE OF THE SLUDGE WAS ORIGINALLY NEAR THE BOTTOM OF THE ROCK CAPS ON THE PEDESTALS. RAIN SINCE THE FLOOD HAS ERRODED ABOUT 0.2 FOOT OF SLUDGE.

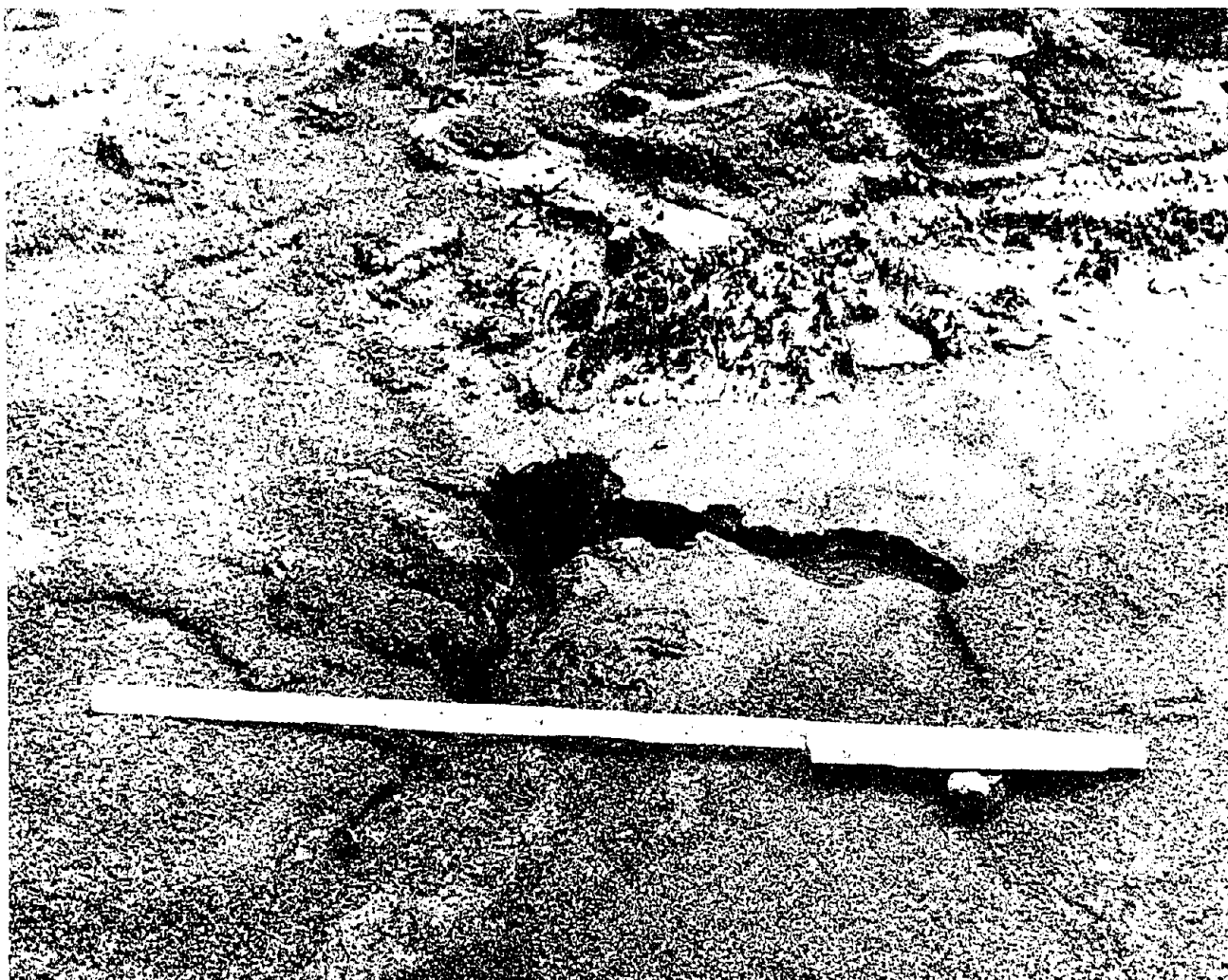

ENTRANCE TO SUBSURFACE CHANNEL IN POOL 2 SLUDGE

3 3 4



STEEPLY DIPPING CONTACT OF POOL 2 SLUDGE AND DAM NO. 3 EMBANKMENT GRAVELS AREA IS AT THE 82° DIP SYMBOL UPSTREAM FROM THE DAM NO. 2 BREACH ON FIGURE VI-20.

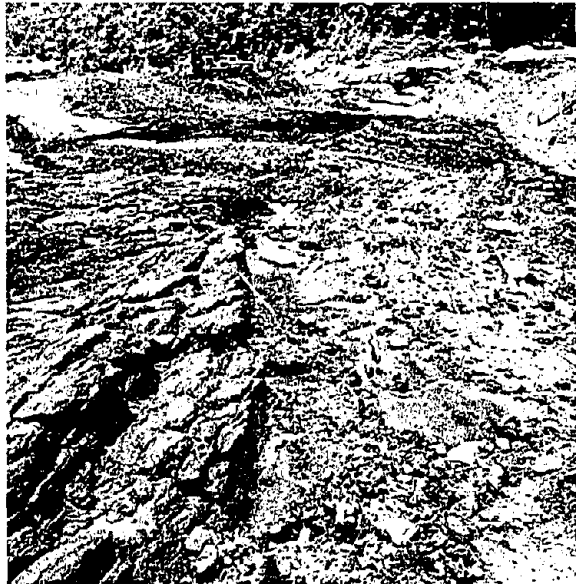

PHOTO A. CONTACT OF POOL 2 SLUDGE AND TRANSLATED DAM NO. 3 EMBANKMENT GRAVEL. VIEW TOWARD DAM NO. 2 BREACH, TAKEN ABOUT 50 FEET DOWNSTREAM OF HOLE S-14. X MARKS PHOTOGRAPHER'S LOCATION FOR PHOTO C, BELOW.

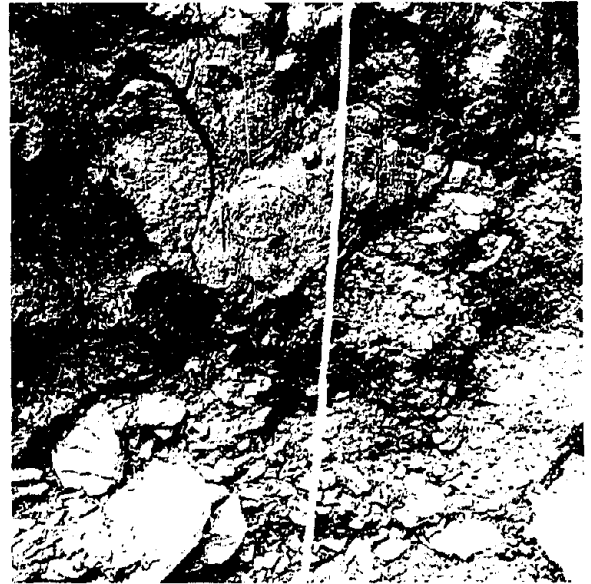

PHOTO B. POOL 2 SLUDGE OVER DAM NO. 2 EMBANKMENT AT THE BREACH OF DAM NO. 2.



PHOTO C. CONTACT OF POOL 2 SLUDGE (AT RIGHT) AND TRANSLATED DAM NO. 3 EMBANKMENT GRAVEL, LOOKING TOWARDS LEFT ABUTMENT OF DAM NO. 3. TAKEN FROM LOCATION MARKED IN PHOTO A, ABOVE. NOTE DOWNSTREAM DIP OF BEDDING IN SLUDGE, MARKED BY SHORT SECTION OF THE RULE.



PHOTO D. IRREGULAR PORTION OF SLUDGE-GRAVEL CONTACT (MIDDLE GROUND AREA OF PHOTO A).

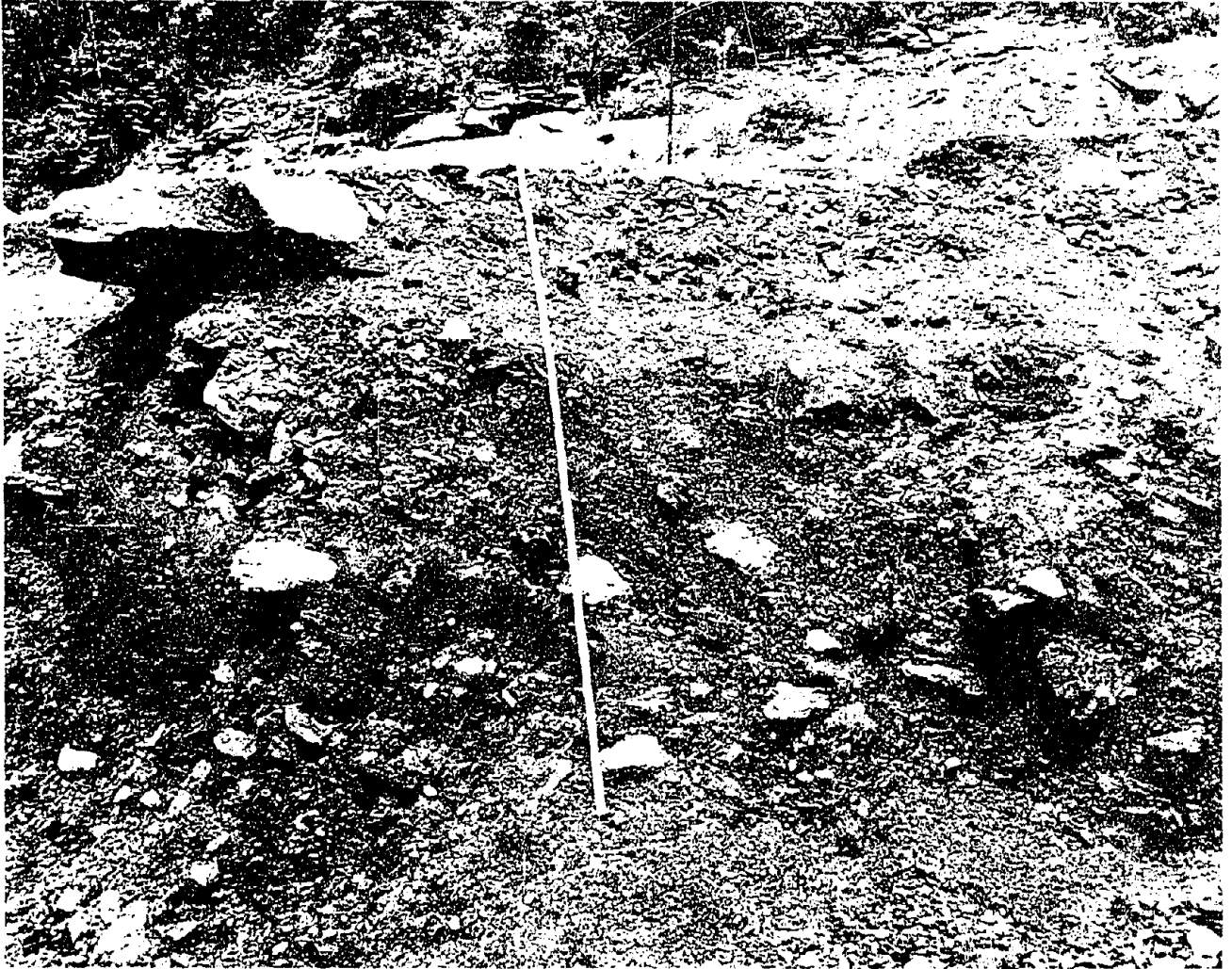

PHOTO OF STREAM BANK 40 FEET SOUTH OF HOLE S-19. THE TOP 1-1 2 - 2 FEET ARE RELATIVELY CLEAN GRAVEL DEPOSITED BY THE FLOOD WATERS. BELOW THE SCOUR LINE IS A COHERENT (BUT TRANSLATED AND ROTATED) PORTION OF THE DAM NO. 3 EMBANKMENT. THE MIDDLE OF THE PHOTO IS AT APPROXIMATELY ELEVATION 1690, PUTTING IT 5 FEET ABOVE THE WATER SURFACE OF POOL 2 WHICH FORMERLY EXISTED HERE

In places, the clean coarse material was several feet thick and, where this thick, it probably represents fill in local channels cut by the flood.

The left abutment remnant of Dam No. 3 is shown on Figures VI-16 and VI-17. Many shallow slides cover the northeast-facing slope of the remnant.

The large circular feature at the base of the left abutment remnant (Figure VI-17) is not only reminiscent of a sinkhole-like structure, but contained dozens of small (1 to 3-foot diameter) sinkholes shortly after the failure. Only one sinkhole remained through early April, and it was filled in by intermittent flooding by mid-April 1972. Two other sinkholes or "sumps" were reported by Davies and others (1972b), only one of which remained by the time we began our field work--its location is about 50 feet downstream of drill hole BS-14. The sinkhole or sump was semi-circular, about 6 feet in diameter, and 4 feet deep. Although we cannot fully explain the origin of these features, they are undoubtedly associated with the occurrence of subsurface flow during or after the failure sequence.

The right abutment remnant of Dam No. 3 (Figure VI-18) is much smaller than the left. Its upstream portion was entirely removed by flood water, indicating the flood flowed here for a considerable time. However, the bedrock is only slightly scoured and eroded. Figure VI-18 also shows numerous trees that were buried by coal refuse as Dam No. 3 was constructed.

An overall aerial view, looking downstream (Figure VI-19) completes the discussion of the site description. This photograph, taken February 28, 1972, shows remarkably well the extent of the roiled area (Pool 2 sludge), the left and right abutment remnants of Dam No. 3, and the stream terraces carved in Dam No. 3 remnants. The prefailure outlines of the dams and pools have been superimposed on the photograph.



DOWNSTREAM PORTION OF LEFT ABUTMENT REMNANT OF DAM NO. 3, FEBRUARY 29, 1972. THE LOW, SCoured MOUND IN THE CENTER EXTENDED TO THE RIGHT DURING THE FIRST STAGES OF THE FAILURE. IN THE FINAL EMPTYING OF POOL 3, THE MOUND WAS DISECTED BY MIDDLE FORK AS SEEN HERE.

136

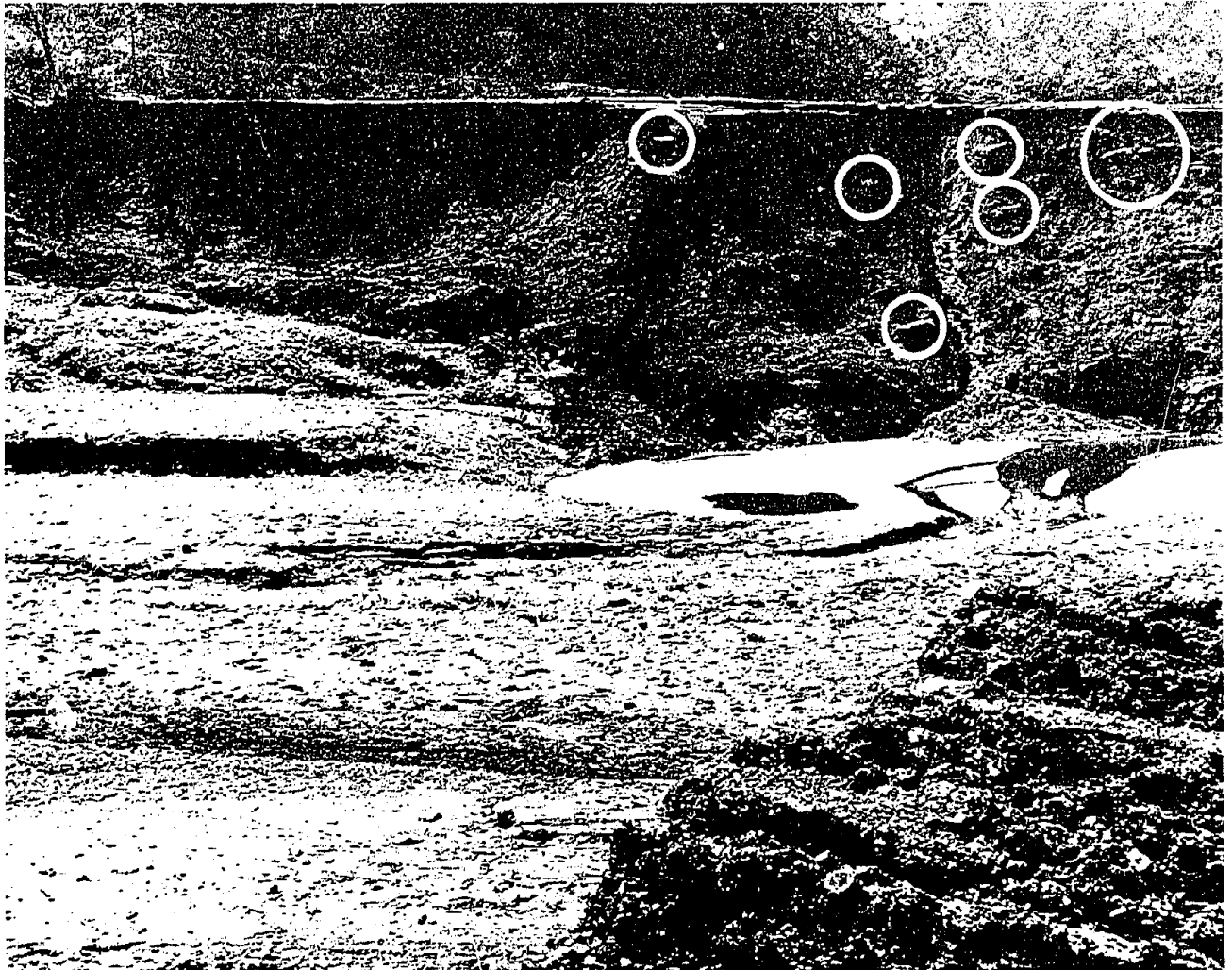

CENTRAL AND UPSTREAM PORTIONS OF THE LEFT ABUTMENT REMNANT OF DAM NO. 3, FEBRUARY 29, 1972.
NOTE THE CONTRAST BETWEEN THE LIGHT, RELATIVELY SAND-FREE STREAM TERRACES AND THE DARK
EMBANKMENT MATERIAL. PORTIONS OF THE SURFACE OF DAM NO. 3 WHICH HAVE SLID TOWARD THE
VIEWER ARE READILY IDENTIFIABLE BY THE HIGHLIGHTS ON THEM (CIRCLED). THE LARGE CIRCULAR
FEATURE AT THE BASE OF THE ABUTMENT REMNANT (RIGHT CENTER) CONTAINED SINKHOLE-LIKE
CAVITIES, ONE TO FOUR FEET IN DIAMETER, SINCE FILLED IN

D 565



RIGHT ABUTMENT OF DAM NO. 3. THE DASHED LINE INDICATES THE PROBABLE LOCATION OF THE UPSTREAM EMBANKMENT CONTACT WITH THE VALLEY WALL.

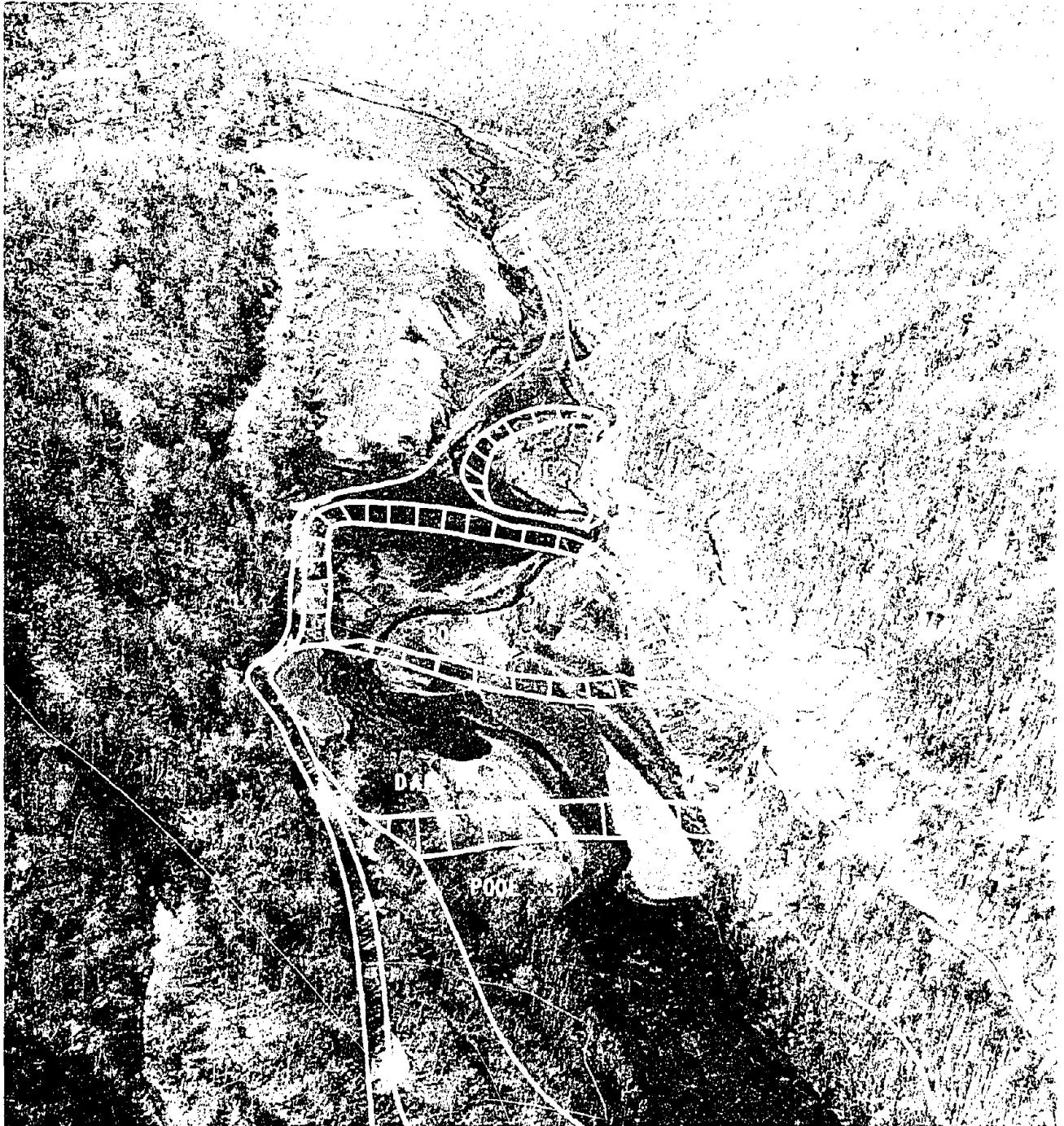

AERIAL VIEW OF MIDDLE FORK VALLEY, LOOKING DOWNSTREAM. THE PREFAILURE OUTLINES OF THE DAMS AND POOLS HAVE BEEN ADDED. PHOTOGRAPH TAKEN FEBRUARY 28, 1972. (PHOTOGRAPH COURTESY OF WEST VIRGINIA DEPARTMENT OF HIGHWAYS.)

C. INTERPRETATION OF POSTFAILURE APPEARANCE

Interpretation of the features described above is based on surficial geologic mapping in combination with data derived from subsurface exploration. Figure VI-20 is a detailed geologic map of the area from just downstream of Dam No. 1 to just upstream of Dam No. 3. Plotted on the map are the postfailure distribution of geologic units (in this case, they are mostly man-made fill and flood deposits), the locations of exploration features (drill holes, pits, density tests, etc.), and the locations of the cross sections presented on Figures VI-21 through VI-24. Several of the photographs herein, particularly the Frontispiece and Figure VI-19, will assist the reader in understanding the contact relations shown on the geologic maps and cross sections. Drill hole logs and field test results are presented in Appendix A.

Features of principal interest on Figure VI-20 are the roiled area of Pool 2 sludge and the contact between it and the translated mass of Dam No. 3 embankment. Map symbols show the structure of the roiled area, and it is also shown on many photographs herein (especially Figures VI-9 through VI-12). The contact between the Pool 2 sludge and the translated Dam No. 3 embankment was explored with backhoe pits, the locations of which are indicated on Figure VI-20. Logs of the pit walls are included in Appendix A (Figure A-6); typical photographs of pit walls are presented on Figure A-4. The roiled area consisted of elongated blocks of Pool 2 sludge which were formed during and after the downstream translation of the slide mass from Dam No. 3. This slide mass pushed the Pool 2 sludge ahead of it, shoving some of it over Dam No. 2. As a result of this movement, the Pool 2 sludge was folded into a series of anticlines (upwarps) and synclines (downwarps), and at the same time broken into a group of steep-sided blocks which jostled about and slid past one another. Some of the sludge later moved through the Dam No. 2 breach (Figure V-2) into the Pool 1 area, and other portions entered Pool 1 by overtopping Dam No. 2. Just left of the former location of the downstream

- NOTES: (1) GEOLOGIC MAPPING BASED ON SITE TOPOGRAPHY AND GEOLOGY AS OF MARCH 9, 1972.
 (2) FOR EXPLORATION FEATURES OUTSIDE THE AREA OF THIS MAP, SEE FIGURES 111-3A, 111-3B, AND 111-3C.
 (3) FOR PRE-FAILURE TOPOGRAPHY SEE FIGURE V-16.
 (4) FIGURE NUMBERS FOR CROSS SECTIONS SHOWN HEREON: A-A' ON VI-21, B-B' ON VI-22, C-C' ON VI-23, AND D-D' ON VI-24.

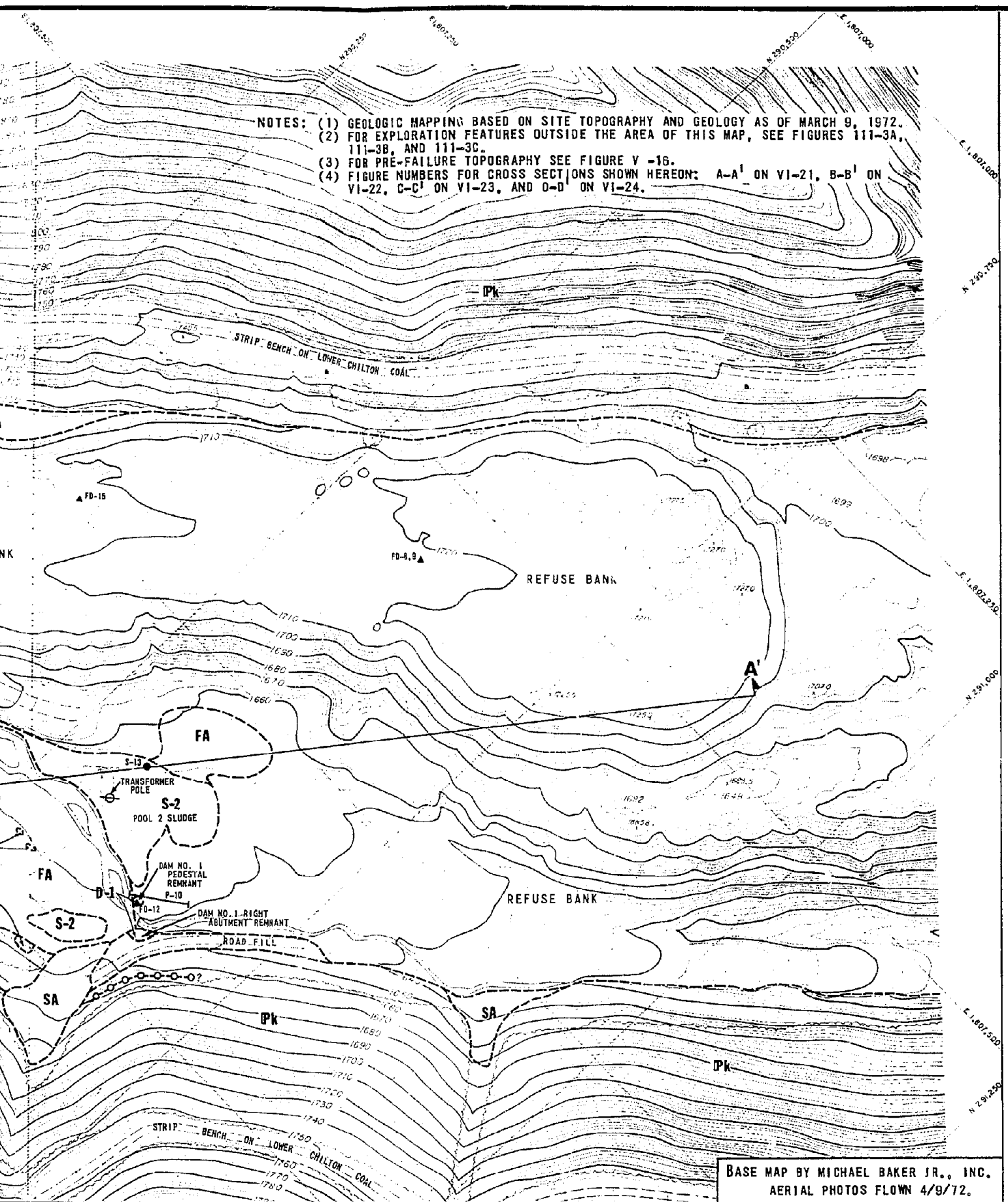

BASE MAP BY MICHAEL BAKER JR., INC.
 AERIAL PHOTOS FLOWN 4/9/72.

EXPLANATION

GEOLOGIC UNITS

HISTORICAL (1947 AND LATER)	FA	FLOOD ALLUVIUM (THIN VENEERS IN CHANNEL SECTION OF DAM NO. 3 NOT SHOWN)
	SA	STREAM ALLUVIUM
	S-1.2.3	SLUDGE OF POOLS 1, 2, AND 3, RESPECTIVELY
	D-1.2.3	REMNANTS OF DAMS 1, 2, AND 3, RESPECTIVELY
	REFUSE BANK	REFUSE BANK, FORMS PORTIONS OF DAMS 1 AND 2
	ROADFILL	ROAD FILL (ONLY MAJOR UNITS SHOWN)
PREG- 201C	COAL WASTE	LOCAL DUMPED COAL REFUSE
	IPK	KANAWHA SERIES, SHOWING COAL SEAM (SEE TEXT)

STRUCTURAL UNITS

	CONTACT BETWEEN UNITS, APPROXIMATELY LOCATED; QUESTIONED WHERE DOUBTFUL OR SPECULATIVE; DOTTED WHERE CONCEALED.
	LANDSLIDE. ARROWS INDICATE DIRECTION OF MOVEMENT; HEADWALL SCARP INDICATED BY HATCHURED AREA.
	LANDSLIDE CRACK (HATCHURES ON LOWER BLOCK)
	FRACTURES AND BLOCK BOUNDARIES IN ROILED AREA (SHORT HATCHURES ON LOWER BLOCK WHERE ELEVATION DIFFERENCES EXIST; LINES DASHED WHERE DOUBTFUL.)
	STRUCTURE CONTOUR ON BASE OF TRANSLATED DAM NO. 3 EMBANKMENT MATERIAL (QUESTIONED WHERE SPECULATIVE).
	STRIKE AND DIP OF BEDDING
	STRIKE OF VERTICAL BEDDING
	APPROXIMATE OR GENERALIZED ATTITUDE OF BEDDING.
	HORIZONTAL BEDDING
	DOMES
	STRIKE AND DIP OF JOINT
	INTERSECTING JOINTS
	STRIKE OF VERTICAL JOINTS
	SYNCLINE
	ANTICLINE

EXPLORATION SYMBOLS

	SAMPLED DRILL HOLE		CONE PENETROMETER (P) AND/OR VANE SHEAR (V)
	UNSAMPLED DRILL HOLE		FIELD TEST, BC-2 = PENETROMETER OR VANE SHEAR TEST IN VICINITY OF DAM NO. 2, BC-3 IN VICINITY OF DAM NO. 3 OR POOL 3, ETC.
	BACKHOE PIT		FIELD DENSITY TEST
	FIELD PERMEABILITY TEST		LINE OF CROSS SECTION

120

W. A. WAHLER & ASSOCIATES	COAL REFUSE DAM FAILURE SAUNDERS, WEST VIRGINIA	GEOLOGIC AND EXPLORATION MAP DAM NO. 1-DAM NO. 3 AREA		
		PROJECT NO. 0700	DATE NOVEMBER 1972	FIGURE NO. VI-20
PALO ALTO • NEWPORT BEACH • CALIF.				

toe of Dam No. 3, a sliver of Pool 2 sludge was displaced laterally and upward to the left as the slide mass moved downstream. This area is shown on Figure VI-25, Photo C, and represents an important piece of evidence indicating a massive slide failure of Dam No. 3.

The mapped contact between translated Dam No. 3 embankment and Pool 2 sludge (Figure VI-20) has a sinuous shape. This unusual configuration results chiefly from two factors: 1) the contact is irregular because it incorporates earlier Dam No. 3 failures, and 2) the contact was warped near the breach of Dam No. 2 as a result of the forces carrying both sludge and gravel through the breach. The contact and sludge beds on Figure VI-13 may, in fact, have been rotated slightly beyond the vertical. While the outcrop pattern of the embankment-sludge contact is defined by both the surficial exposures and the shallow backhoe pits, its subsurface location was defined best by drill holes. The bottom surface of the translated mass of Dam No. 3 embankment is defined by structure contours on Figure VI-20. These contours are based on drill hole data, slide geometry, depth to bedrock, and the thickness of the sludge below the dam; they are, therefore, interpretive.

In cross section A-A' on Figure VI-21, the embankment-sludge contact is defined by drill hole evidence. The approximate prefailure outline of Dam No. 3 embankment is also shown. It is tempting to think of the embankment-sludge contact line on section A-A' as a single or unique slide plane, purely on the basis of observation. Indeed, interpretation of the contact shown on that section as the main failure surface is generally supported by the engineering analyses presented in Chapter VII. However, the structure contours on Figure VI-20 represent conditions after all sliding had ceased, and the surface they define is the final failure surface; that is, the main failure surface as modified by subsequent failures. A determination of the failure sequence of Dam No. 3 must rely on field observation and engineering analyses and also take into account salient points of eyewitness reports. Our step-by-step account of the failure of Dam No. 3 is presented in Chapter VII.

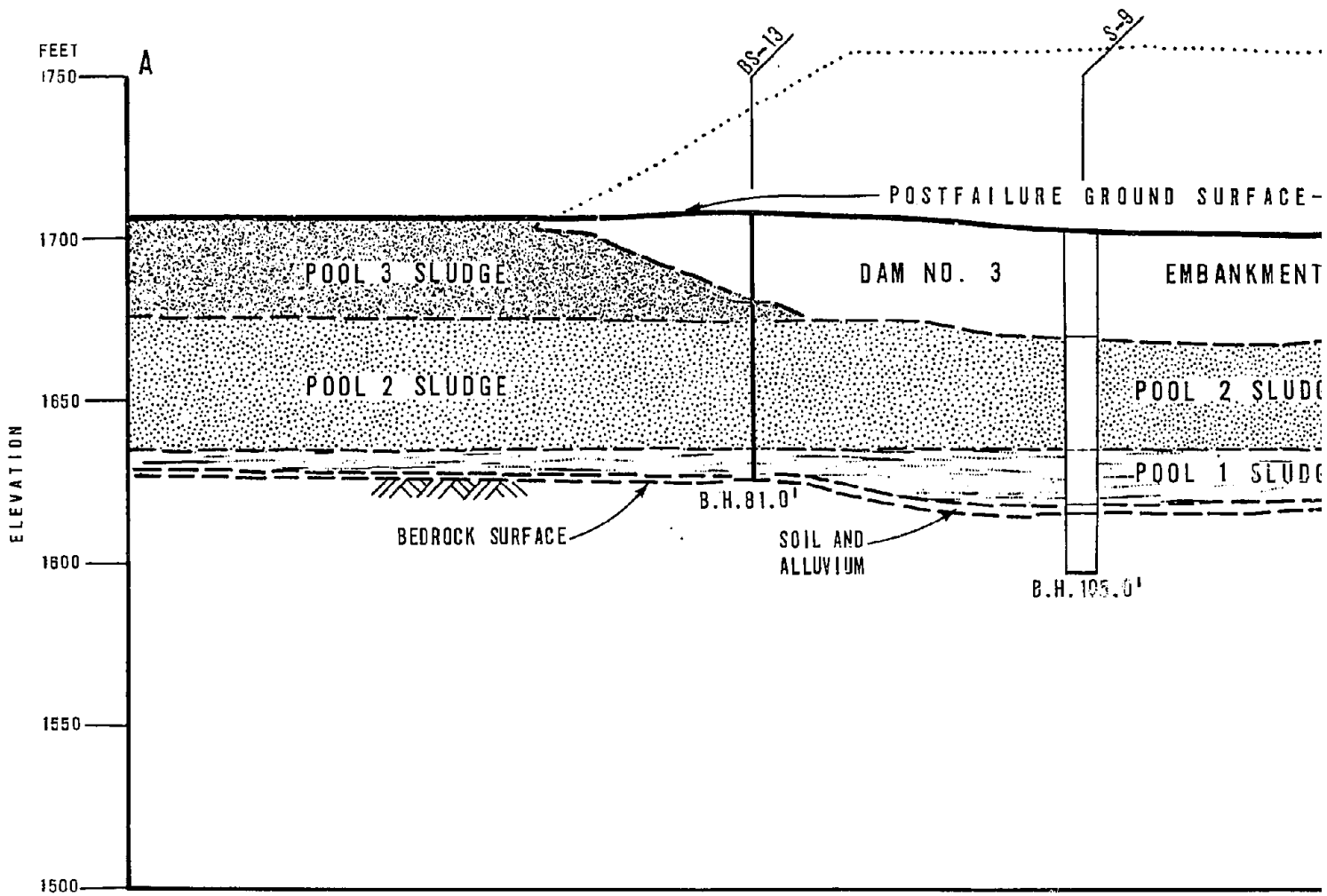

- NOTES: (1) FOR LOCATION OF SECTION SEE FIGURE VI-20.
 (2) FOR PREFAILURE SECTION, SEE FIGURE V-17.
 (3) PATTERNS USED FOR THE SLUDGE OF POOLS 1, 2, AND 3 ARE FOR DELINEATION ONLY AND ARE NOT MEANT TO SUGGEST TEXTURE OR COMPOSITION.

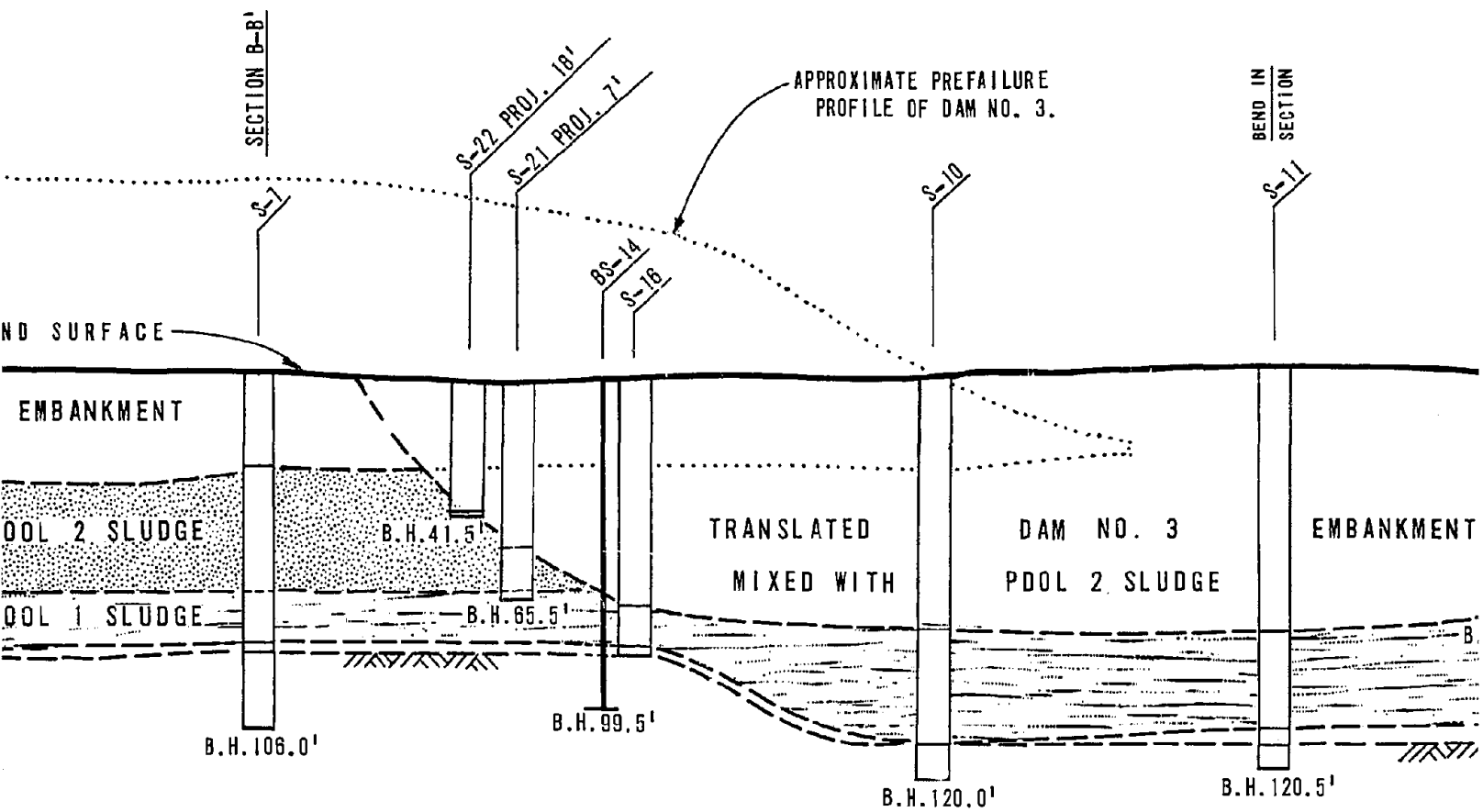

KANAWHA SERIES

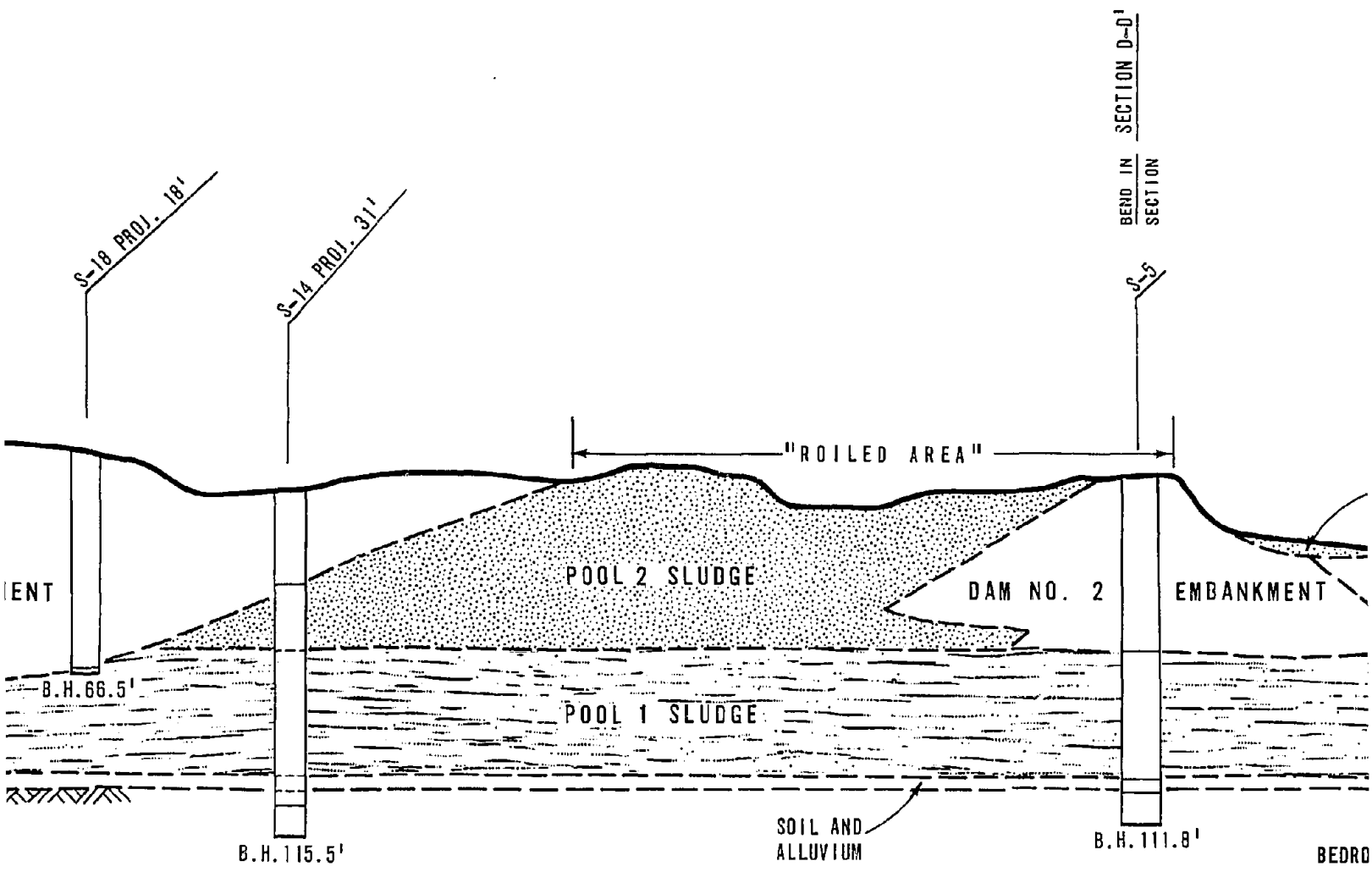

SECTION A-A'



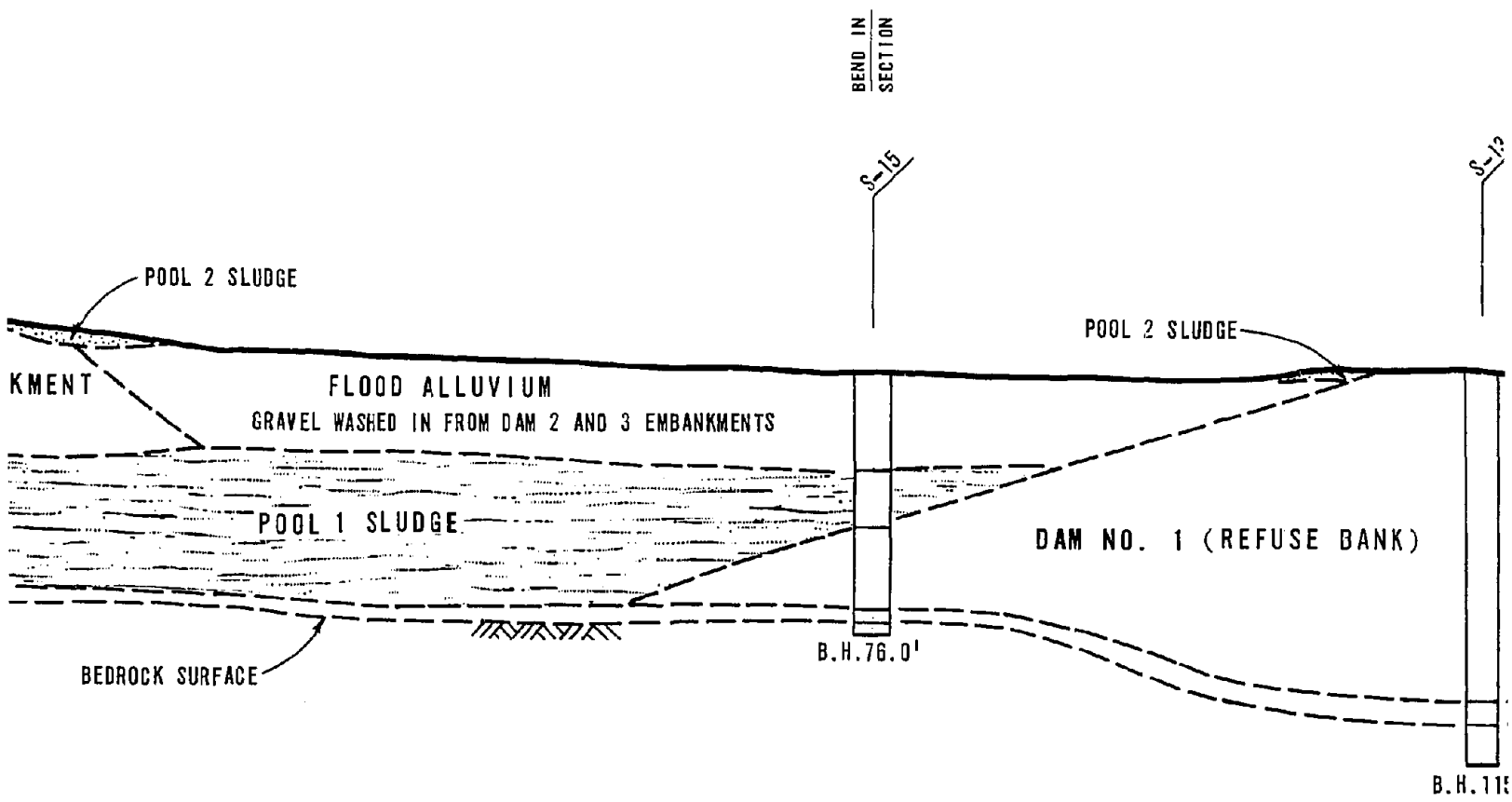

50 FEET

KEY

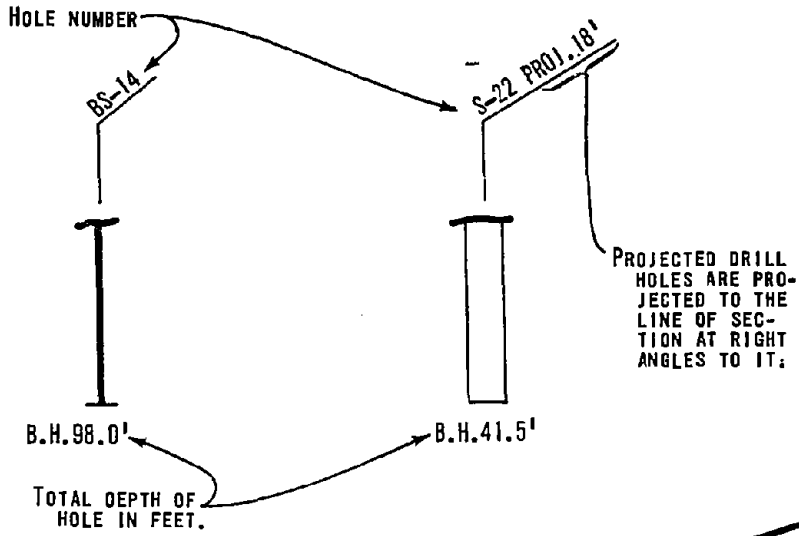

DAM NO. 1 (REFU

KANAWHA SERIES

W.A. WAHLER
& ASSOCIATES

COAL REFUSE D/
SAUNDERS, WEST

PALO ALTO • NEWPORT

INJECTED DRILL
 IDLES ARE PRO-
 JECTED TO THE
 LINE OF SEC-
 TION AT RIGHT
 ANGLES TO IT.

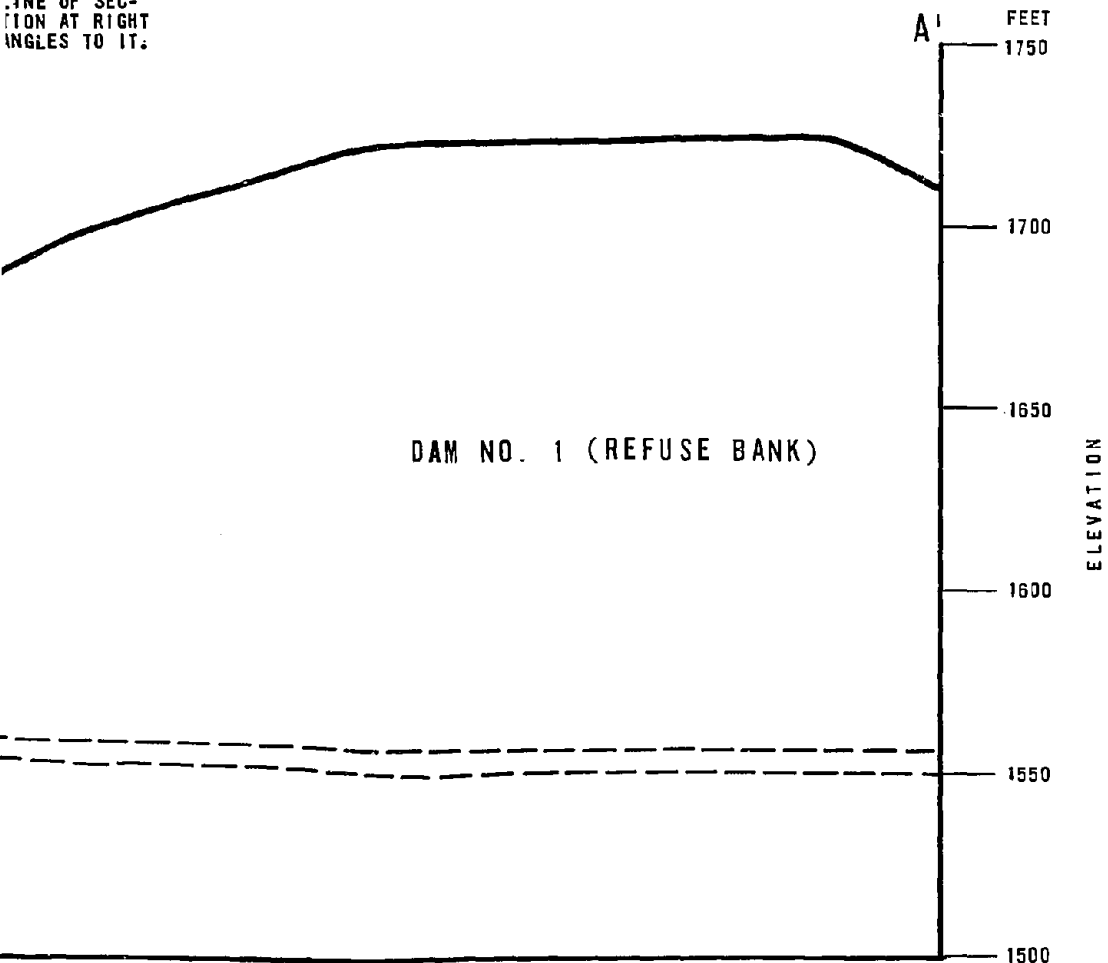

DAM NO. 1 (REFUSE BANK)

W.A. WAHLER & ASSOCIATES	COAL REFUSE DAM FAILURE SAUNDERS, WEST VIRGINIA <small>PALO ALTO • NEWPORT BEACH • CALIF.</small>	GEOLOGIC CROSS SECTION A-A' (POSTFAILURE)		
		<small>PROJECT NO.</small> 0700	<small>DATE</small> NOVEMBER 1972	<small>DRAWING NO.</small> VI-21

Cross section B-B' (Figure VI-22) is drawn along the crest of Dam No. 3. It defines the valley walls of Middle Fork Valley below the dam, and also shows how the dam was constructed over layers of sludge in pre-existing pools. The prefailure profile of the dam crest is also shown. Sections C-C' and D-D' on Figures VI-23 and VI-24, respectively, illustrate Dam No. 2. Figure VI-26 is a diagrammatic sketch of Middle Fork Valley, postfailure.

One final aspect of the field evidence remains to be discussed in this chapter: the stream terraces carved in Dam No. 3 embankment by the flood water. The aerial view on Figure VI-19 makes some of the stream terraces obvious by their varying tones. Other photographs (Figures V-7 and VI-27) show the terraces as seen on the ground. For our purposes, a stream terrace is defined as a former stream channel; a place where water formerly flowed. They are identified by the presence of alluvial deposits typical of stream channel bottoms, and by their characteristic shape in profile. Scour action has reworked the inundated portions of Dam No. 3 to depths of about 2 feet as shown on Figure VI-15 and removed most of the fine-grained fraction, leaving a clean veneer of coarse material. Thus, the embankment areas formerly covered by flood waters are readily identifiable (Figure VI-17). As the flood flow decreased, it could not occupy the entire width of its original channel and eroded successively narrower channels, leaving remnants of the older channels "high and dry." These remnants have been delineated on Figure III-3B as stream terraces 1 through 5; terrace 1 being the lowest and most closely related to the present channel, and terrace 5 being the highest and earliest formed terrace. Of course, other terraces could have been formed and then destroyed. Nonetheless, by analyzing the plan and profile of the mapped terraces, the final stages of the flood flow from Pool 3 may be outlined.

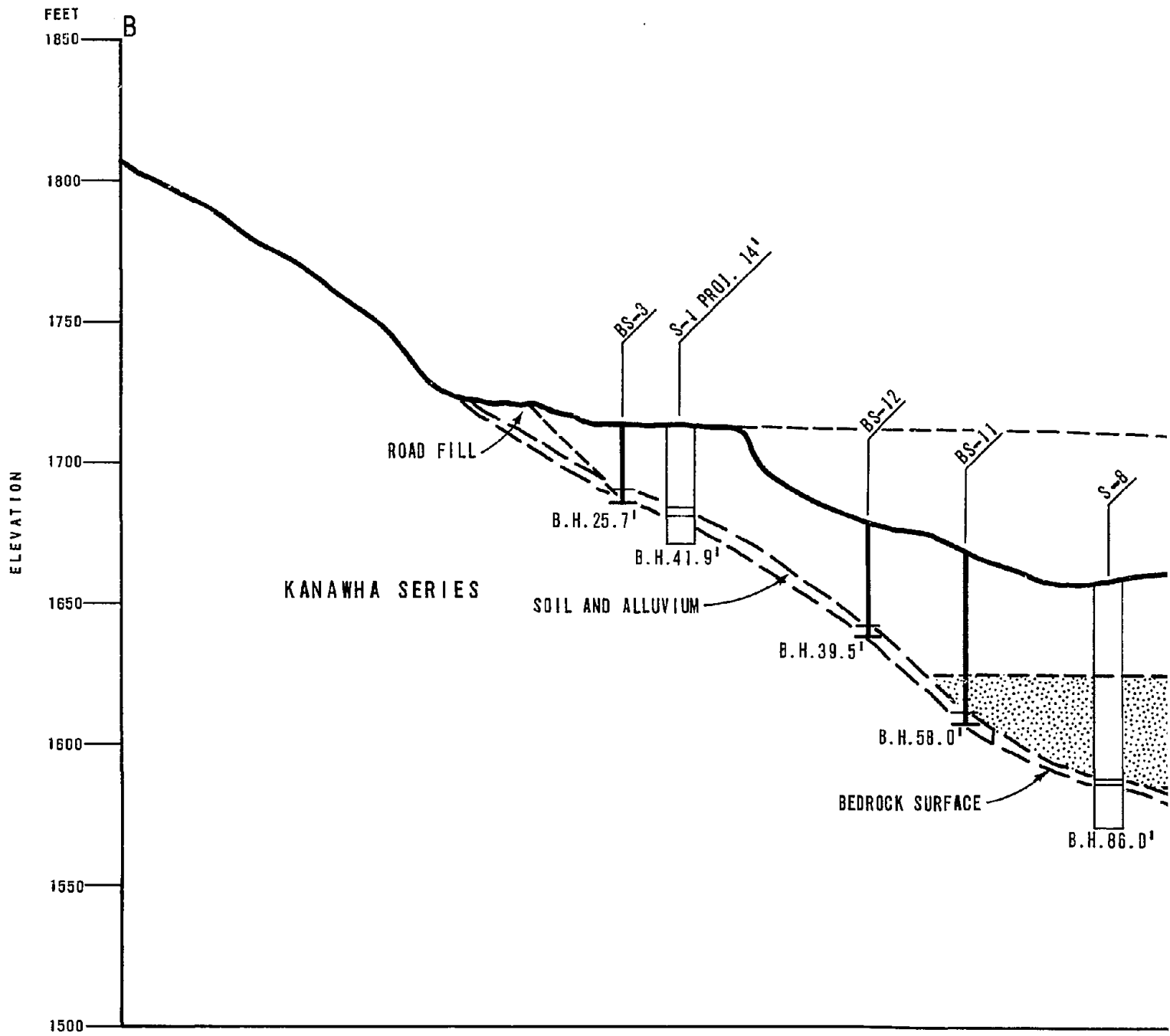

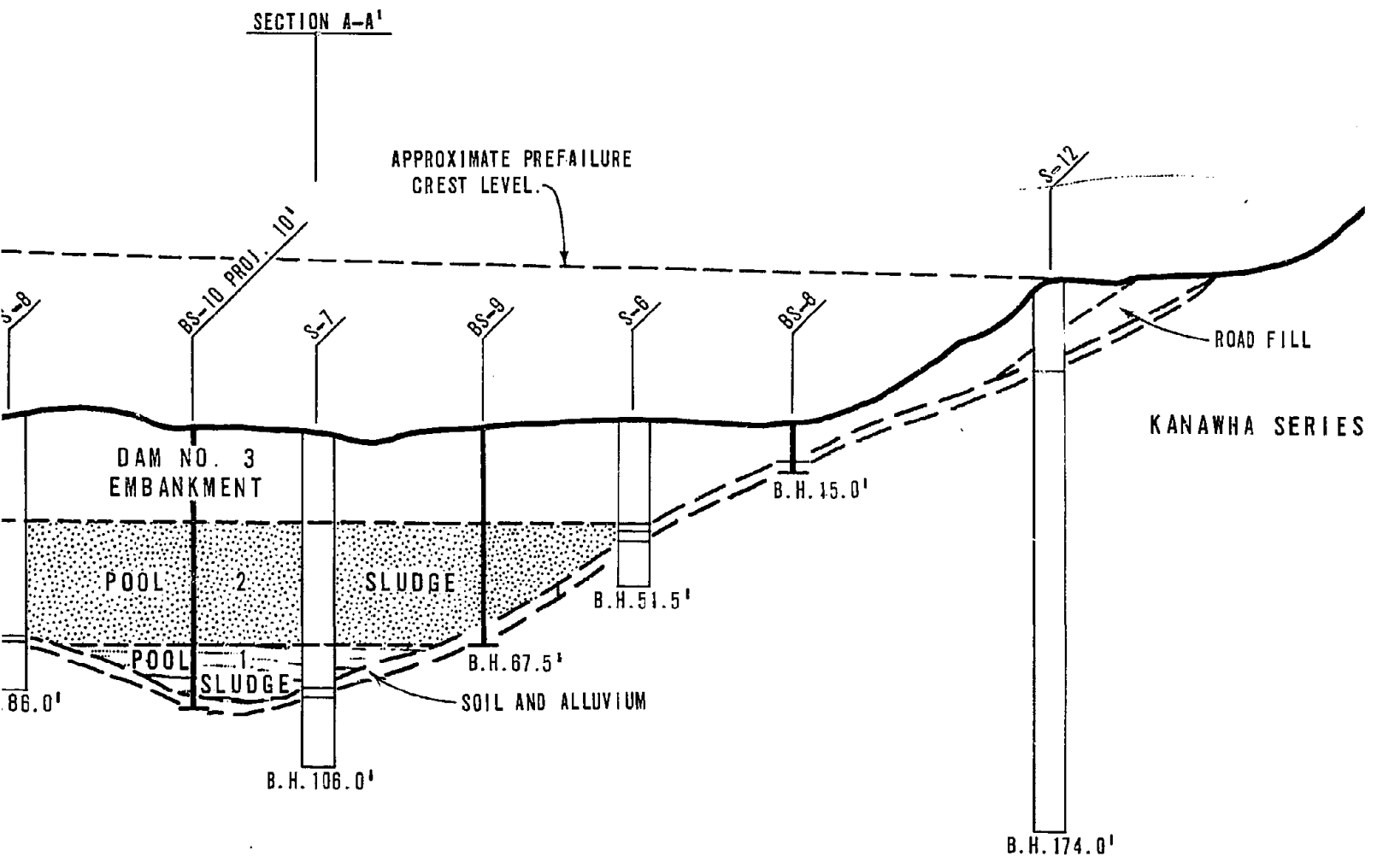

SECTION B-B'

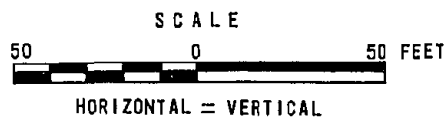

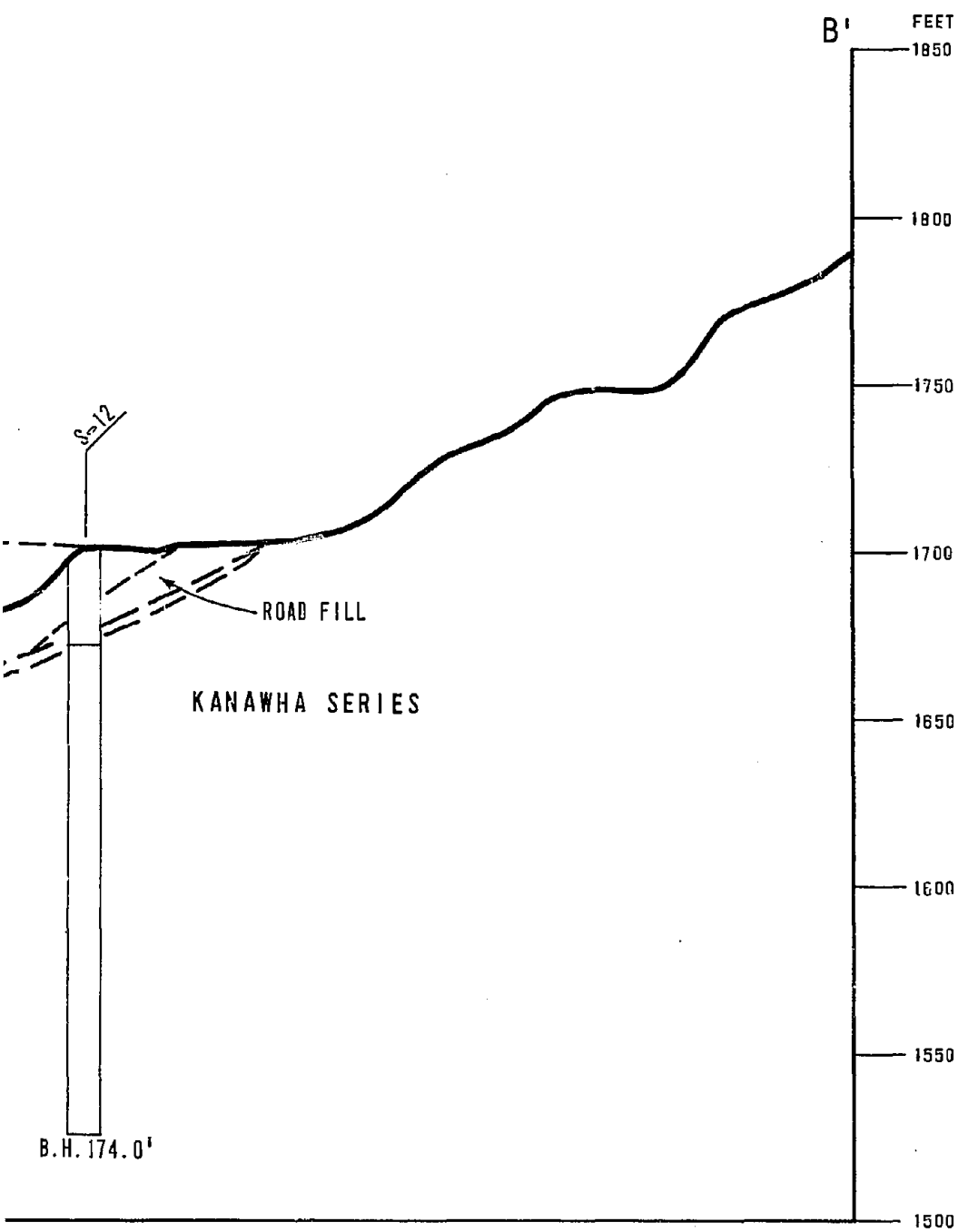

KEY

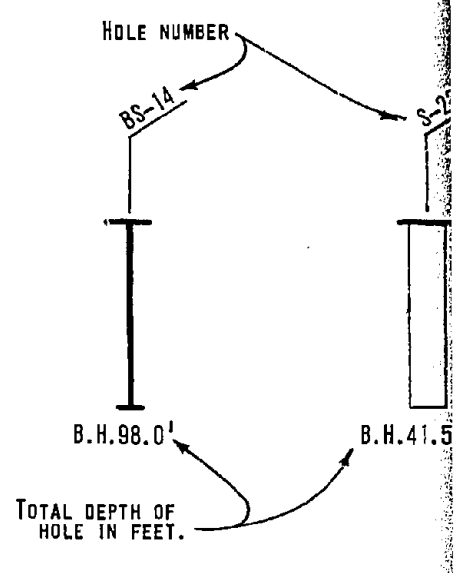

- NOTES: (1) FOR LOCATION OF SECTION,
 (2) FOR DRILL HOLE LOGS SEE
 (3) PATTERNS USED FOR THE SLI
 2 ARE FOR DELINEATION ON
 TO SUGGEST TEXTURE OR COI

W. A. WAHLER & ASSOCIATES	COAL REFUSE DAM FAILURE SAUNDERS, WEST VIRGINIA	GEOLOG
	PALO ALTO • NEWPORT BEACH • CALIF.	PROJECT NO. 0700

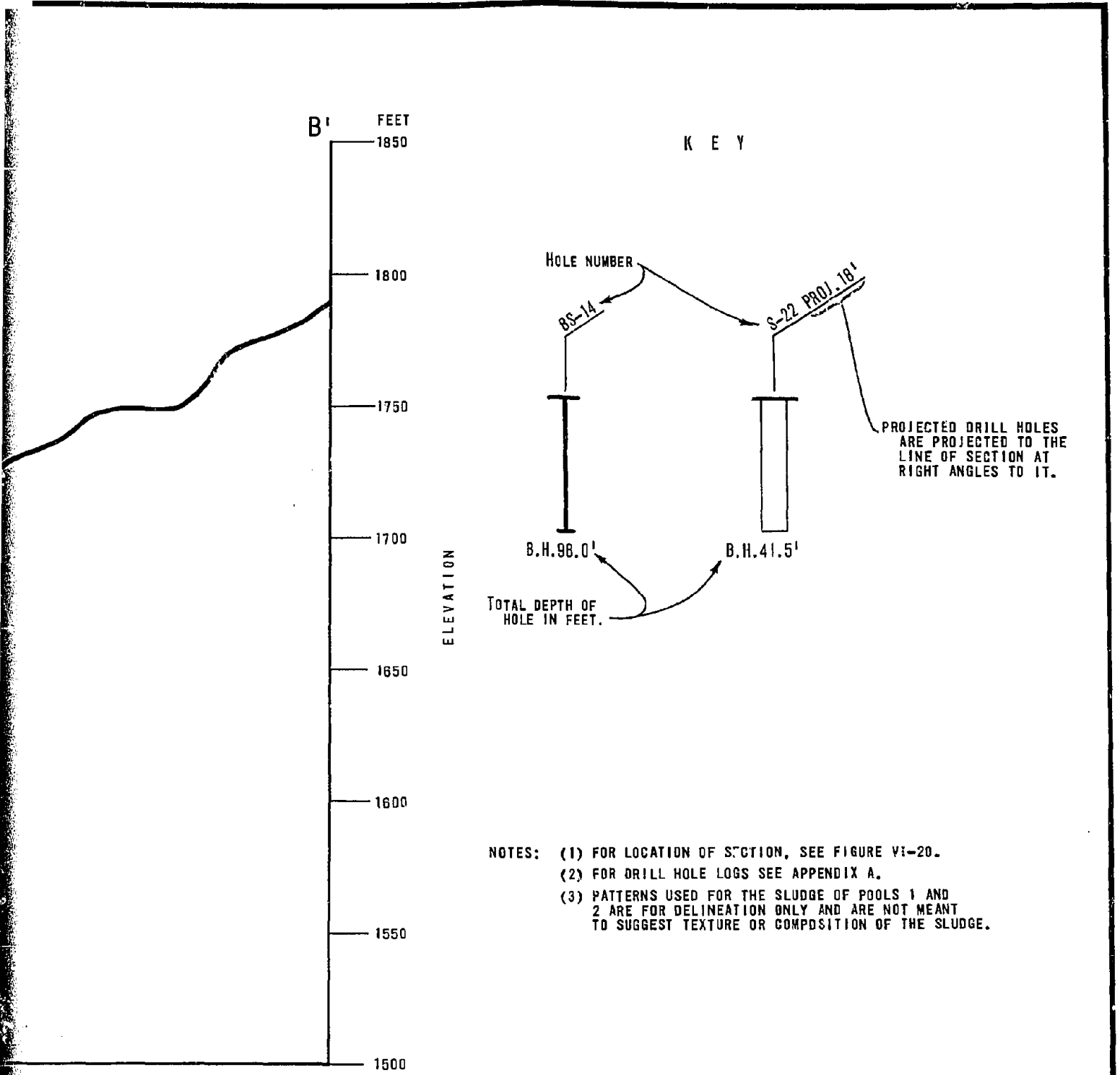

W. A. WAHLER & ASSOCIATES	COAL REFUSE DAM FAILURE SAUNDERS, WEST VIRGINIA PALO ALTO • NEWPORT BEACH • CALIF.	GEOLOGIC CROSS SECTION B-B' (POSTFAILURE)		
		PROJECT NO. 0700	DATE NOVEMBER 1972	FIGURE NO. VI-22

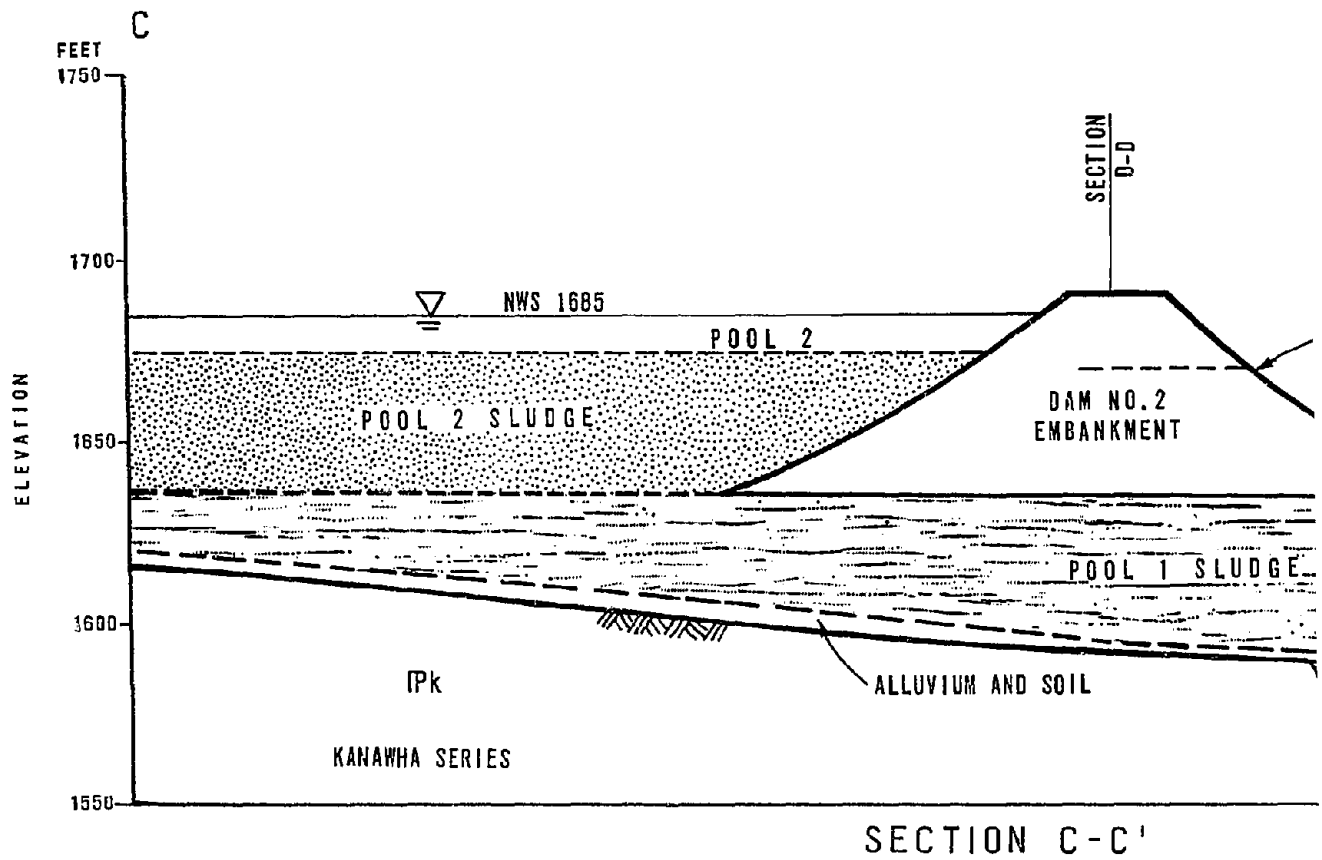

- NOTES: (1) FOR POSTFAILURE VIEW SEE CORRESPONDING PORTION OF SECTION A-A' (FIGURE VI-21).
 (2) FOR LOCATION OF SECTION SEE FIGURE VI-20.
 (3) PATTERNS USED FOR THE SLUDGE OF POOLS 1 AND 2 ARE FOR DELINEATION ONLY AND ARE NOT MEANT TO SUGGEST TEXTURE OR COMPOSITION.

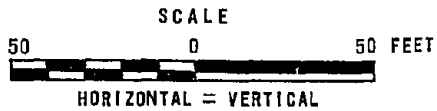
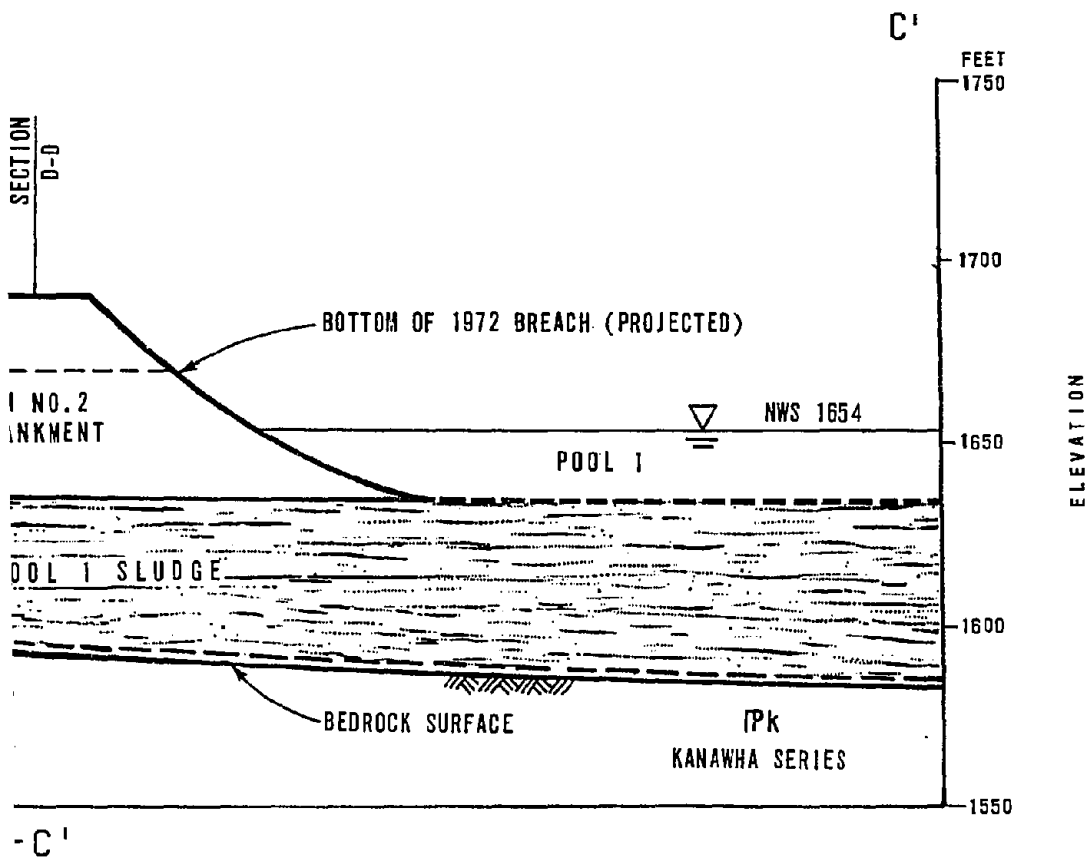

125

W.A. WAHLER & ASSOCIATES	COAL REFUSE DAM FAILURE SAUNDERS, WEST VIRGINIA PALO ALTO • NEWPORT BEACH • CALIF	DAM NO. 2 GENERALIZED PREFAILURE CROSS SECTION		
		PROJECT NO.	DATE	FIGURE NO.
		0700	NOVEMBER 1972	VI-23

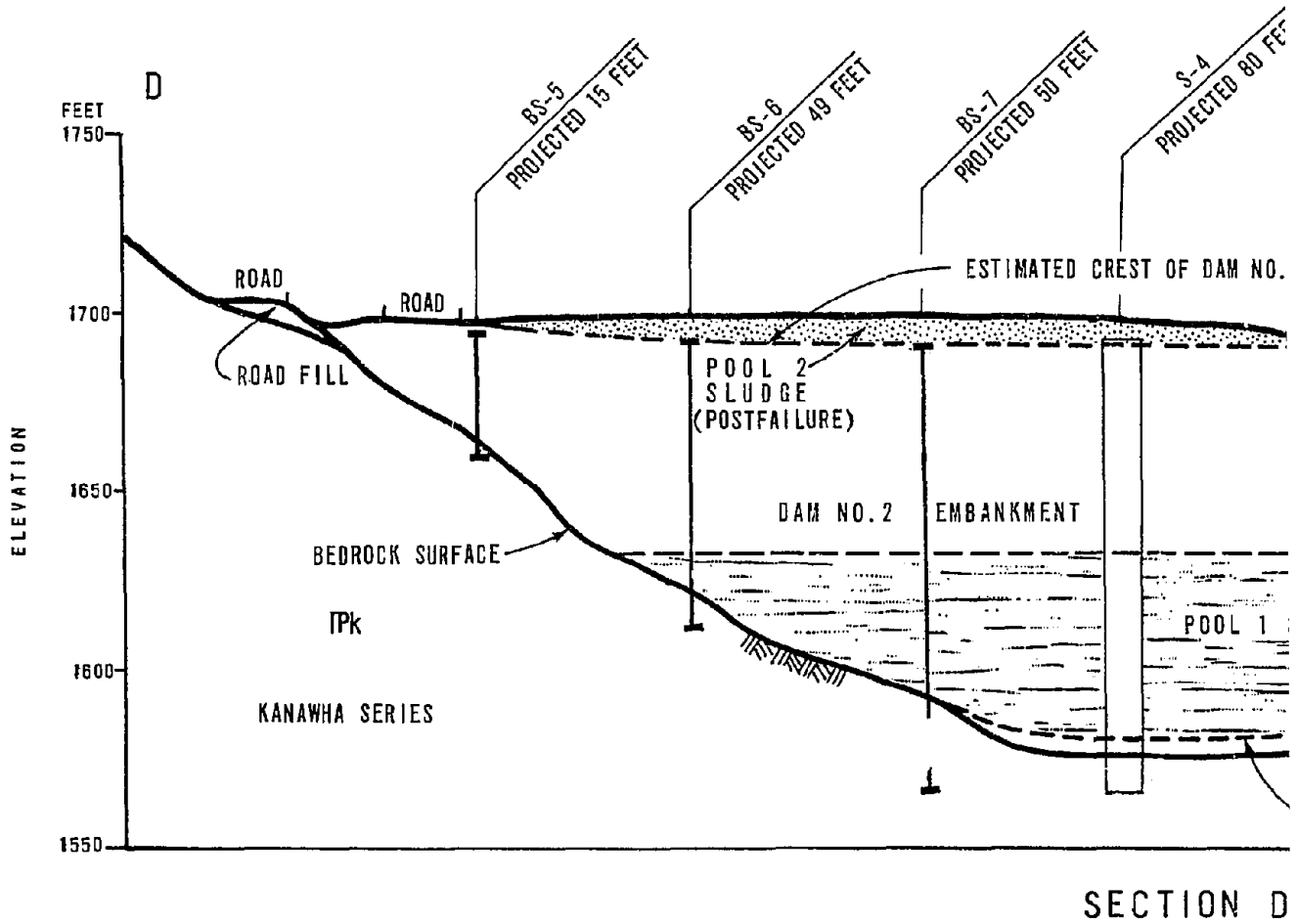

- NOTES: (1) PROJECTED DRILL HOLES ARE PROJECTED TO THE LINE OF SECTION AT RIGHT ANGLES TO IT.
- (2) FOR LOCATION OF SECTION SEE FIGURE VI-20.
- (3) PATTERNS USED FOR THE SLUDGE OF POOLS 1 AND 2 ARE FOR DELINEATION ONLY AND ARE NOT MEANT TO SUGGEST TEXTURE OR COMPOSITION.

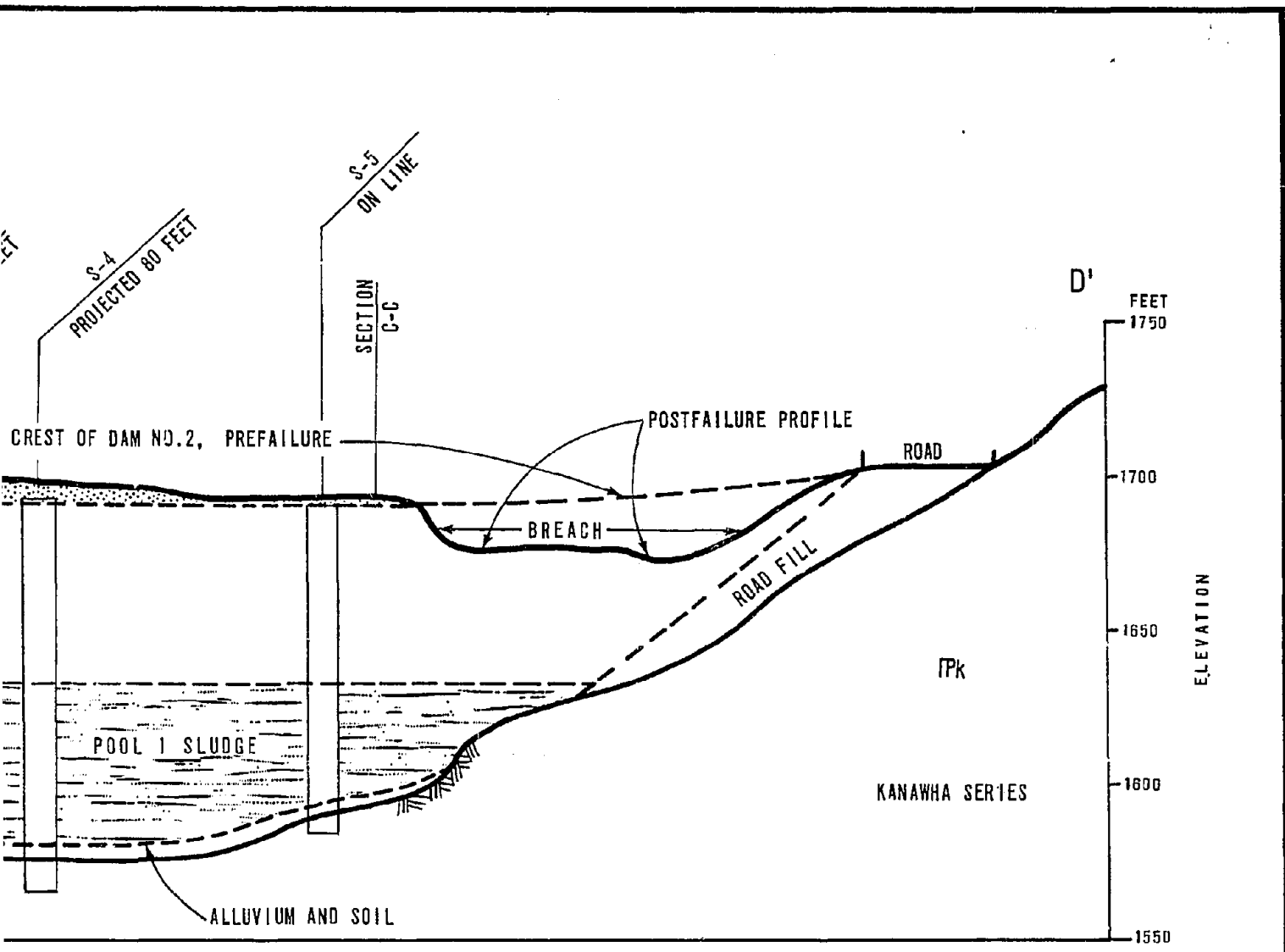

SECTION D-D'

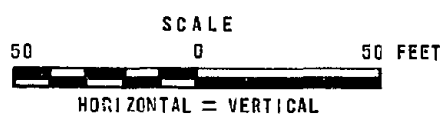

W.A. WAHLER & ASSOCIATES PALO ALTO • NEWPORT BEACH • CALIF.	COAL REFUSE DAM FAILURE SAUNDERS, WEST VIRGINIA	TRANSVERSE SECTION, DAM NO. 2		
		PROJECT NO. 0700	DATE NOVEMBER 1972	FIGURE NO. VI-24

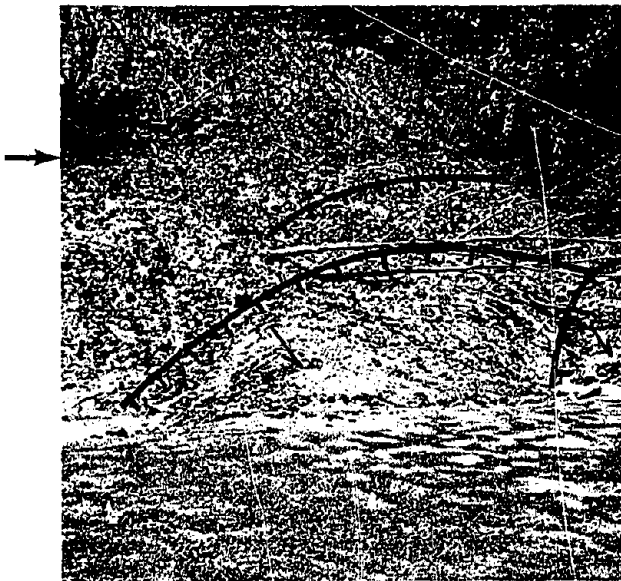

PHOTO A. SECONDARY SLIDES DEVELOPED ALONG LEFT SIDE OF POOL 2 IN TRANSLATED DAM NO. 3 EMBANKMENT. ARROW INDICATES HIGH-WATER LINE OF FLOOD WATER AT ABOUT ELEVATION 1711-1712. FIGURE VI-8 WAS TAKEN FROM THE TOP OF THE SLOPE JUST OUT OF VIEW AT THE UPPER LEFT.



PHOTO B. POOL 2 SLUDGE ON BRANCH AT APPROXIMATELY ELEVATION 1700, 50 FEET SOUTHEAST OF HOLE BS-5.



PHOTO C. POOL 2 SLUDGE IN LEFT FOREGROUND, DAM NO. 3 EMBANKMENT SLIDE ON RIGHT. PHOTO TAKEN JUST DOWNSTREAM OF THE FORMER LOCATION OF LEFT TOE OF DAM NO. 3. ARROW INDICATES DIRECTION OF MOVEMENT OF THE SLIDE.

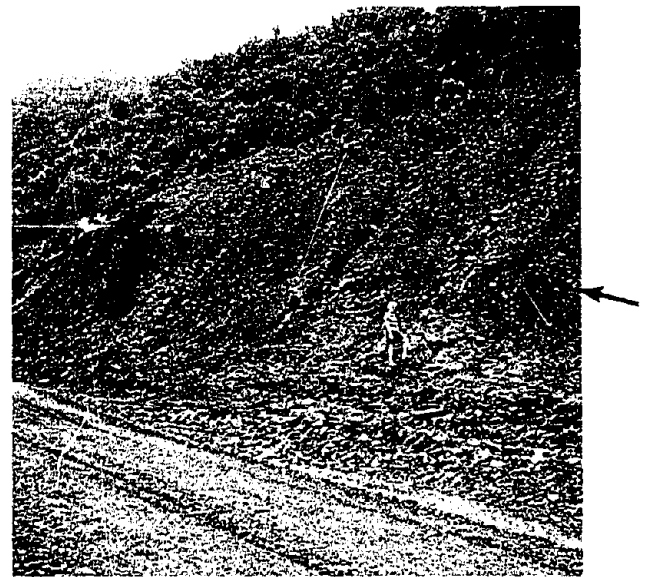

PHOTO D. HIGH-WATER LINE (ARROW) ON SIDE OF REFUSE BANK SOUTHWEST OF HOLE S-13.

127



MIDDLE FORK VALLEY, POSTFAILURE

128



PHOTO A. PHOTO TAKEN AT RIGHT OF HOLE S-11, LOOKING DOWNSTREAM. ENTIRE TERRACE AREA IS LARGELY FREE OF SAND AT SURFACE; THE FLOOD WATERS SCOURING THE BOTTOM REMOVED MOST OF THE SAND, TYPICALLY TO DEPTHS OF 2 TO 4 FEET.

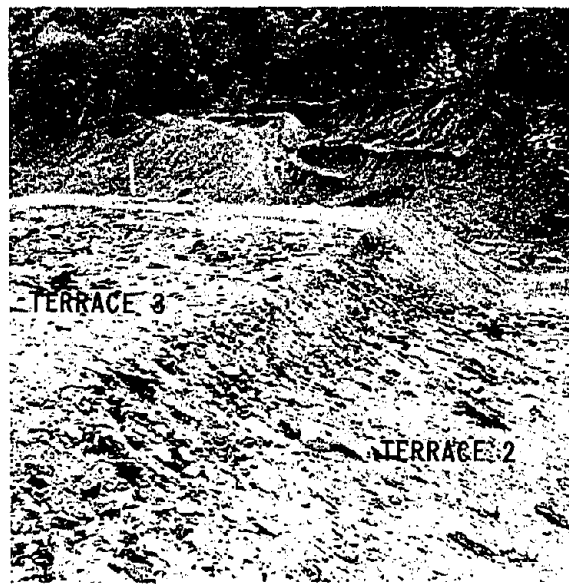

PHOTO B. FLOOD STREAM TERRACES NEAR FORMER TOE OF DAM NO. 3, LOOKING TOWARDS LEFT ABUTMENT REMNANT OF DAM NO. 3 FROM NEAR HOLE S-18. STAKE AT TOP OF MOUND ON TERRACE 3 IS AT HOLE S-11. FOR MAP OF TERRACES, SEE FIGURE 111-3B.



PHOTO C. INCIPIENT STREAM TERRACE DEVELOPED ON REFUSE BANK BY FLOOD WATER, NEAR HIGHEST POOL 2 SLUDGE (FIGURE VI-4). AREA IN FRONT OF LINE IS THE SAME TERRACE, BUT IS COVERED WITH A LAYER OF POST-FLOOD FILL.



PHOTO D. TERRACE 5 AT EXTREME UPSTREAM END OF DAM NO. 3 LEFT ABUTMENT REMNANT. FOR MAP OF TERRACES, SEE FIGURE 111-3B.

CHAPTER VII

REFUSE DAM FAILURE

A. GENERAL

As a part of our overall investigation of the failure of Dam No. 3, a number of different studies were performed in order to arrive at the conclusions presented in this report. The principal objectives of this chapter are to present a detailed discussion of the engineering properties of the materials comprising the waste dams and their foundations, the engineering analyses performed during the course of our investigation, our conclusions regarding the sequence of events which led up to the ultimate failure of the dams, and a description of the most probable failure mode.

B. MATERIALS PROPERTIES

1. General

The behavior of soils and related materials such as coal waste is largely controlled by their engineering properties which, in turn, are influenced by particle structure, density, and degree of saturation. By means of physical testing, the effects and interaction of mineral composition, rheology, chemistry, mineralogy, particle arrangement, density, strength, intergranular contact, etc., can be evaluated. When evaluating a dam failure, a major effort is always required to develop a coordinated program of laboratory and in situ materials testing in order to establish the basic soil engineering properties which are fundamental data input for the engineering analyses. Such a program was conducted for materials comprising the dams and foundations in the Middle Fork Valley to permit analysis of the conditions leading to dam failure.

The determination of physical properties involves not only the performance of appropriate tests, but also the application of considerable judgment to interpret and evaluate materials property test results. The field investigation, discussed in detail in Appendix A, was programmed to establish the materials composition and distribution within the dam embankments and foundations. The laboratory investigation, described in detail in Appendix B, was programmed to develop the pertinent soil engineering characteristics of the various coal waste materials for use in the engineering analyses.

All test results are compiled in Appendices A and B. The following types of tests were performed.

Index Properties

1. Soil Classification
2. Particle-Size Distribution
3. Atterberg Limits (Plasticity)
4. Specific Gravity
5. Moisture Content and Density

Engineering Properties

1. Permeability (Field and Laboratory Determination)
2. In Situ Shear Strength (Vane Shear Method)
3. Penetration Resistance
4. Triaxial Shear Strength
 - a) Effective Stress
 - b) Total Stress
5. Critical Hydraulic Gradient
6. Compressibility

2. Embankments

While design, selection, and distribution (zoning) of embankment materials all influence and play important roles in the post-construction stability and performance of a dam, only through proper construction techniques can the satisfactory behavior of the material be assured. For any given soil with a specified gradation, all of the engineering properties listed above vary, depending upon the in-place density. The more compact a material, the lower is its permeability and compressibility, the higher its strength parameters and penetration resistance, and the higher its critical hydraulic gradient. Since any one of these properties can cause instability, if inordinately low or high, it follows that construction methods and techniques are of primary importance to long-term dam stability.

As discussed in Appendix A, it was difficult to obtain good undisturbed samples of the remaining portions of the embankments because of their coarse material composition. Additionally, because major portions of the embankments were removed by the failure, the field testing was necessarily performed in rather limited areas defined by the left and right embankment remnants. Even with these difficulties, however, the correlation of embankment engineering properties between samples obtained by various methods was satisfactory.

The average gradation characteristics of the embankment materials for Dams 2 and 3 were determined from a total of 34 gradation tests, of which 18 were performed on undisturbed tube samples, and 16 were performed on disturbed samples such as those obtained from field density tests. The results of the gradation tests are presented on Figure VII-1 in the form of the total range of all tests and the average gradation as determined from undisturbed and disturbed samples. As noted on Figure VII-1, the average gradations for the coarse-grained coal waste embankment material, as determined by the two sampling methods, are remarkably similar.

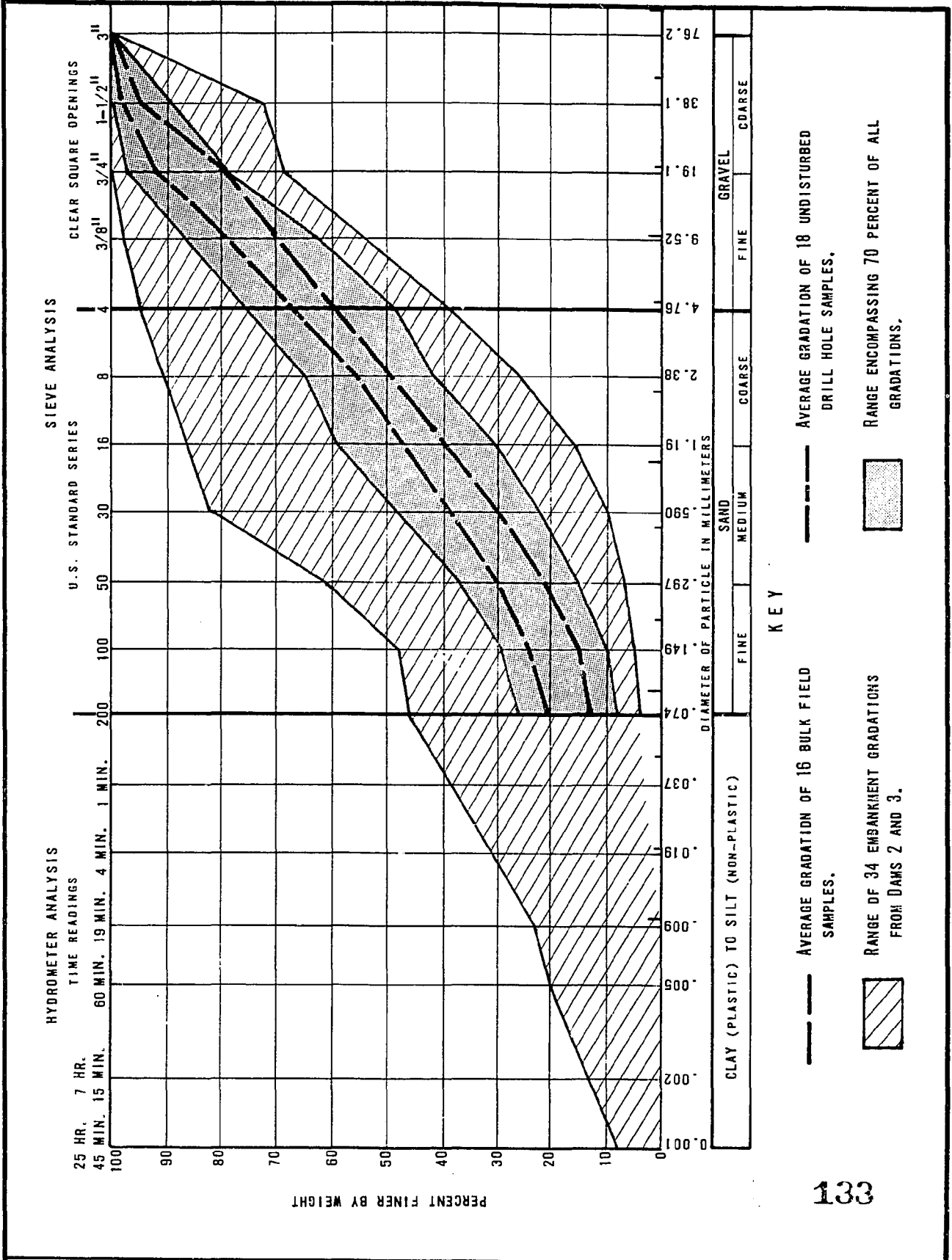

KEY

- AVERAGE GRADATION OF 16 BULK FIELD SAMPLES.
- RANGE OF 34 EMBANKMENT GRADATIONS FROM DAMS 2 AND 3.
- AVERAGE GRADATION OF 18 UNDISTURBED DRILL HOLE SAMPLES.
- ▨ RANGE ENCOMPASSING 70 PERCENT OF ALL GRADATIONS.

W. A. WAHLER & ASSOCIATES	COAL REFUSE DAM FAILURE SAUNDERS, WEST VIRGINIA	GRADATION SUMMARY		
		COARSE COAL WASTE (EMBANKMENT) MATERIAL		
		PROJECT NO	DATE	DRAWING NO
		0700	NOVEMBER 1972	VII-1
PALO ALTO • NEWPORT BEACH • CALIF				

A review of the in-place dry density test results also shows a very good correlation between those obtained by undisturbed 3-inch diameter tube samples and those of the 12-inch diameter field density samples. Figure VII-2 delineates the distribution of dry density by occurrence frequency obtained from undisturbed drill hole samples while Figure VII-3 presents the frequency distribution of dry density for both the 3-inch diameter tube samples and the in-place field density testing.

In determining the specific gravity of the embankment material, it was necessary to use a weighted average of the various percentages of materials present because of the difference in specific gravity between the shale and coal fractions of the material. The weighted average of the specific gravity for the embankment, as determined from the data presented in Table B-4, is 1.95. The weighted median value of specific gravity is also 1.95, where embankment materials gradations are typically in the range of 65 percent finer than No. 4 sieve, 20 percent between the No. 4 to 3/4 inch, and 15 percent greater than 3/4 inch.

The permeability characteristics of the embankment materials were determined by evaluating the construction methods, by observations at the site, and from field and laboratory test results. This determination indicates that it is unlikely that any significant difference between the horizontal and vertical permeability existed in the original embankment. Furthermore, because a reported 300,000 gallons per day inflow to Pool 3 was maintained for prolonged periods without significant fluctuation of the reservoir surface, a significant flow through the embankment was occurring. The results of the field permeameter and laboratory tests, presented in the Appendices on Table A-1 and on Figure B-7, as well as permeability coefficients calculated from the known discharge through Dam No. 3, indicate a range for all values between 10^{-2} and 10^{-5} cm/sec with a typical value of 2×10^{-4} cm/sec.

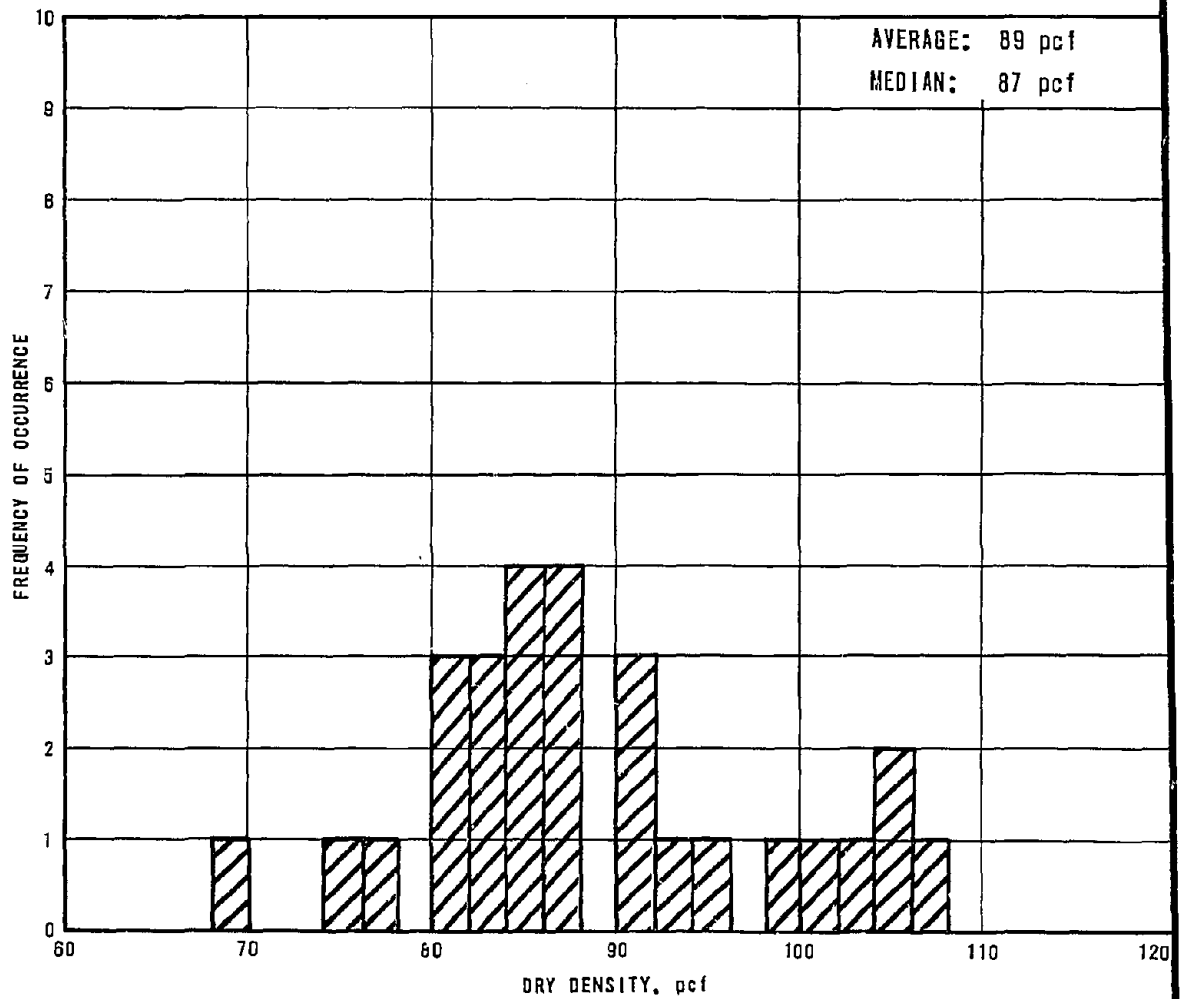

- NOTES: (1) THE DATA SHOWN HEREON, WHICH IS PRESENTED IN ITS ORIGINAL FORM IN TABLE B-1, REPRESENT DRY DENSITIES OF SELECTED EMBANKMENT MATERIALS AS DETERMINED FROM UNDISTURBED DRILL HOLE SAMPLES.
- (2) A STATISTICAL EVALUATION OF THESE DATA WAS NOT PERFORMED BECAUSE THE SAMPLE SELECTION PROCESS COULD PRECLUDE A RANDOM VARIATION OF SAMPLED DATA.
- (3) NOT INCLUDED IN THE FREQUENCY DISTRIBUTION ARE TEST RESULTS REPRESENTING DISTURBED, TRANSLATED OR MIXED MATERIALS.

135

W. A. WAHLER
& ASSOCIATES

COAL REFUSE DAM FAILURE
SAUNDERS, WEST VIRGINIA

DRY DENSITY FREQUENCY DISTRIBUTION
EMBANKMENT MATERIAL

FALO ALTO • NEWPORT BEACH • CALIF.

PROJECT NO.
0700

DATE
NOVEMBER 1972

FIGURE NO.
VII-2

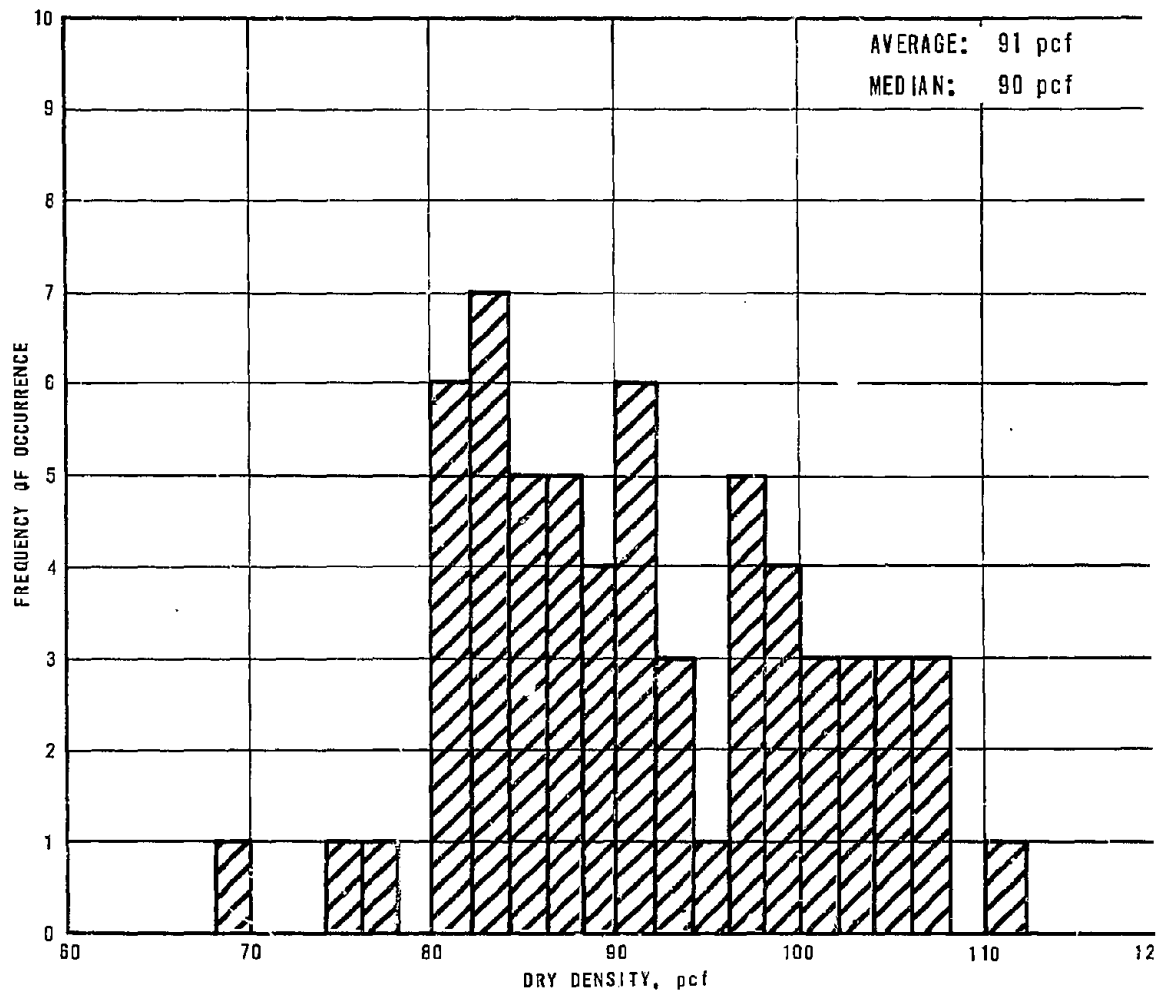

- NOTES: (1) THE DATA SHOWN HEREON, WHICH IS PRESENTED IN ITS ORIGINAL FORM IN TABLES A-2 AND B-1, REPRESENT DRY DENSITIES OF SELECTED EMBANKMENT MATERIALS AS DETERMINED FROM BOTH IN-PLACE FIELD DENSITIES AND UNDISTURBED DRILL HOLE SAMPLES.
- (2) A STATISTICAL EVALUATION OF THESE DATA WAS NOT PERFORMED BECAUSE THE SAMPLE SELECTION PROCESS COULD PRECLUDE A RANDOM VARIATION OF SAMPLED DATA.
- (3) NOT INCLUDED IN THE FREQUENCY DISTRIBUTION ARE TEST RESULTS REPRESENTING DISTURBED, TRANSLATED OR MIXED MATERIALS.

136

W. A. WAHLER
& ASSOCIATES

COAL REFUSE DAM FAILURE
SAUNDERS, WEST VIRGINIA

PALO ALTO • NEWPORT BEACH • CALIF.

DRY DENSITY FREQUENCY DISTRIBUTION
EMBANKMENT MATERIAL

PROJECT NO.	DATE	FIGURE NO.
0700	NOVEMBER 1972	VII-3

The characteristics of the coarse coal waste materials used for construction of the refuse dams were not constant. The coal refuse was extracted from the Kanawha Series which contains shales found to exhibit intense slaking when subjected to cycles of wetting and drying. There is some evidence that shale slaking also occurs even in the waste pile. When larger shale particles slake (Figure VII-4), the breakdown is occasionally to thin platelets, some to 1/8 inch thick and three to six inches on a side. More commonly, the shale disintegrates to roughly equidimensional particles of about 1/8 inch on a side and further weathering proceeds to form clay particles. These phenomena, however, did not appear to adversely affect the ability of Dam No. 3 to drain freely under normal inflow conditions.

As mentioned in Chapter VI, the refuse bank was burning at both its downstream end and near Pool 1 at the time of the failure. However, since Dams 2 and 3 remained quite wet through most of their life, ignition did not occur, and the characteristics of burned coal waste material are, therefore, not pertinent to the analysis of Dams 2 and 3.

Shear strength characteristics for use in the detailed stability analyses were determined by testing both undisturbed field samples and laboratory fabricated samples. Furthermore, undisturbed samples were tested in our portable laboratory in Logan, West Virginia as well as in our main Palo Alto laboratory in an attempt to determine if there was any reduction in strength due to conventional shipment and handling of samples. The laboratory fabricated samples were tested and the results compared with those from the undisturbed samples in order to determine what influence, if any, could be associated with the method of construction as it influenced the structure or orientation of individual particles. Obviously, any inherent or built-in structure exhibited by the coarse-grained embankment material would be observed in the undisturbed samples and not in the laboratory fabricated samples.

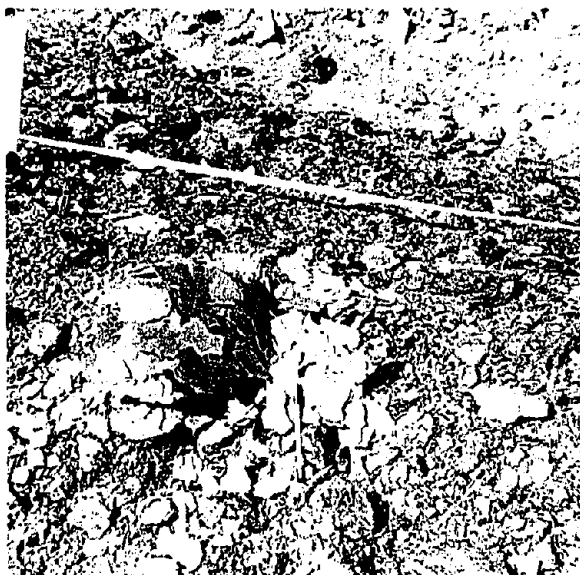

PHOTO A. SLAKING SHALE ON LEFT ABUTMENT REMNANT OF DAM NO. 3. A RARE MODE OF SLAKING ON THE SITE, THE SHALE HERE SLAKES INTO BRITTLE PIECES ABOUT 1/16 INCH THICK. FOR SCALE, PEN IS 6 INCHES LONG.



PHOTO B. SLAKING SHALE ON LEFT ABUTMENT REMNANT OF DAM NO. 3. FAR MORE COMMON THAN THE SLAKING MODE ILLUSTRATED ABOVE, HERE THE SHALE SLAKES INTO PUNKY, SOFT FRAGMENTS LESS THAN 1/2 INCH LONG. FOR SCALE, LENS CAP IS 2-3/8 INCHES IN DIAMETER.

Two strength envelopes were developed based on consolidated undrained triaxial tests on fabricated samples and six additional envelopes were developed based on triaxial testing of undisturbed drill hole samples. Figure VII-5 represents the total and effective shear strength envelopes resulting from a comparison of all eight individual envelopes. A distinct trend was defined in the variation of the total stress envelope with respect to initial dry density. This approximate variation is indicated by the dashed envelopes on Figure VII-5.

The engineering properties of the embankment materials used in the engineering analyses are summarized below:

EMBANKMENT MATERIALS

<u>Engineering Property</u>	<u>Value Used in Analyses</u>
Dry Density	90 pcf
Wet Density	106 pcf
Coefficient of Permeability	2×10^{-4} cm/sec
Permeability Ratio (Horizontal to Vertical)	1:1
Specific Gravity	1.95
 Shear Strength Parameters	
Effective Stress	For Normal Stress less than 16 psi $\phi' = 41^\circ$ $c' = 0$
	For Normal Stress greater than 16 psi $\phi' = 34^\circ$ $c' = 500$ psf
Total Stress	$\phi = 17^\circ$ $c = 700$ psf

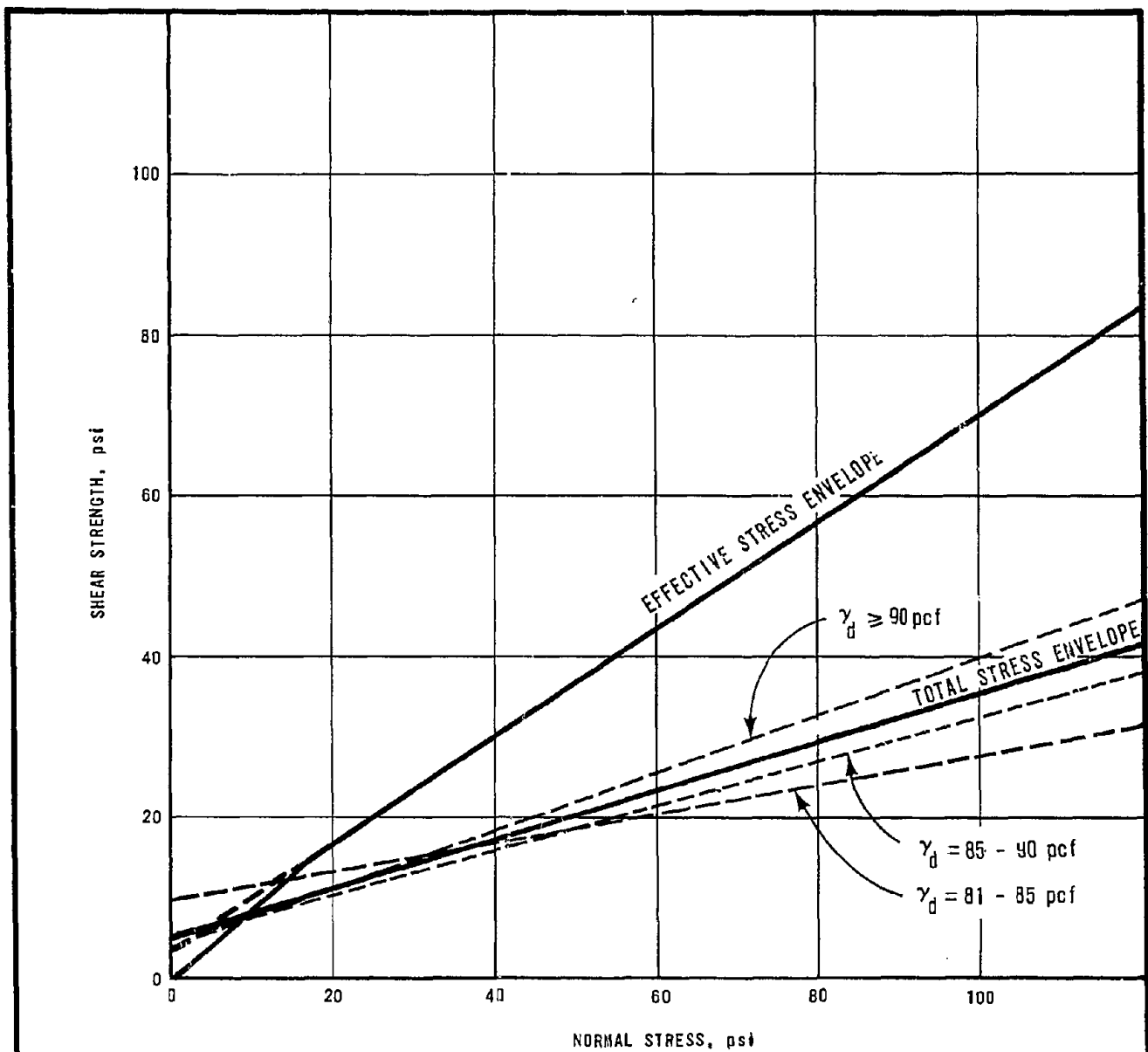

EFFECTIVE STRESS PARAMETERS

$\bar{\sigma} < 16 \text{ psi} = 2.3 \text{ ksf}$
 $\phi' = 41^\circ$
 $c' = 0$
 $\bar{\sigma} > 16 \text{ psi} = 2.3 \text{ ksf}$
 $\phi' = 34^\circ$
 $c' = 3.5 \text{ psi} = 0.5 \text{ ksf}$

TOTAL STRESS PARAMETERS

$\phi = 17^\circ$
 $c = 4.9 \text{ psi} = 0.7 \text{ ksf}$

NOTES: (1) THE ENVELOPES SHOWN REPRESENT THE AVERAGE SHEAR STRENGTH CHARACTERISTICS OF 19 UNDISTURBED AND 6 LABORATORY FABRICATED SAMPLES.
 (2) SEE APPENDIX B FOR DETAILED RESULTS.

140

W.A. WAHLER & ASSOCIATES	COAL REFUSE DAM FAILURE SAUNDERS, WEST VIRGINIA	EMBANKMENT MATERIALS SHEAR STRENGTH PARAMETERS		
		PROJECT NO. 070D	DATE NOVEMBER 1972	FIGURE NO. VII-5

The engineering properties of the embankment materials referenced above do not exhibit exceptionally unusual characteristics when compared to soil-like material conventionally used for earth dam construction. Furthermore, the engineering properties of the coarse-grained embankment materials were not notably affected by conventional transportation of field samples, and no significant difference was found in the shear strength parameters for both undisturbed and laboratory fabricated samples at equal densities.

3. Foundations

As discussed previously, the materials providing foundation support for Dams 2 and 3 were deposited by discharge of coal waste sludge into Middle Fork from Buffalo Mining Company No. 5 Preparation Plant. The discharge point into Middle Fork Valley was about one mile upstream of Dam No. 3. The discharge was first ponded behind (upstream) Dam No. 1 in the Middle Fork Valley upon a thin layer of alluvium; drilling data indicated that the alluvium varies between two to six feet in thickness and is underlain by the very hard and competent bedrock of the Kanawha Series. When the level of sludge approached the crest elevation of Dam No. 1, Dam No. 2 was constructed upstream upon the coal waste sludge which had been retained behind Dam No. 1. This same scheme was employed for Dam No. 3 except its location was such that coal waste sludge impounded by both Dams 1 and 2 was contained in its foundation. Broken trees and in-place tree stumps were observed at the foundation level of Dam No. 3 after failure (Figure VI-18) indicating that the sludge waste was ponded without prior stripping of trees and debris.

Drilling and sample extraction in the sludge deposits did not encounter unusual difficulties, although some modifications to standard procedures were required to minimize sample disturbance and to maximize sample recovery. These modifications are described in Appendix A. For

similar reasons discussed previously, some of the foundation sludge samples were tested in our portable laboratory while the remaining samples were shipped to our main laboratory. It became evident after completing the initial testing that, because of the rather low specific gravity of the fine-grained foundation sludge material, the thickness and in-place density of the sludge would be of particular significance in the analysis of foundation stability. Based upon historical development of dams and sludge pools in the Middle Fork Valley, both portions of the two-layered foundation beneath Dam No. 3 were expected to have similar behavioral characteristics.

Composite gradation curves for representative foundation sludge materials are presented on Figure VII-6. These materials are described as sandy silt to silty sand under the Unified Soil Classification System. For the solid portion of the coal waste sludge pumped from the No. 5 Preparation Plant, and typically the material providing foundation support for Dams 2 and 3, an average specific gravity of 1.43 was obtained, with a range of 1.34 to 1.66. The higher values represent materials having less coal content and higher proportions of the Kanawha shales and sandstones.

A number of in-place dry densities were determined by laboratory testing of Shelby tube samples in order to evaluate the relative compaction of the foundation sludge material. Only a limited number of field density tests were performed because of unavailability of these materials as a result of the flooding associated with the dam failure. Regardless, however, the field density tests did confirm the range of dry density variation obtained from undisturbed samples. The in-place dry density data are presented in Appendix B, Figure B-1 and summarized on Figure VII-7.

The maximum dry density for a representative sample of the foundation sludge material was determined to be only 57 pounds per cubic foot.

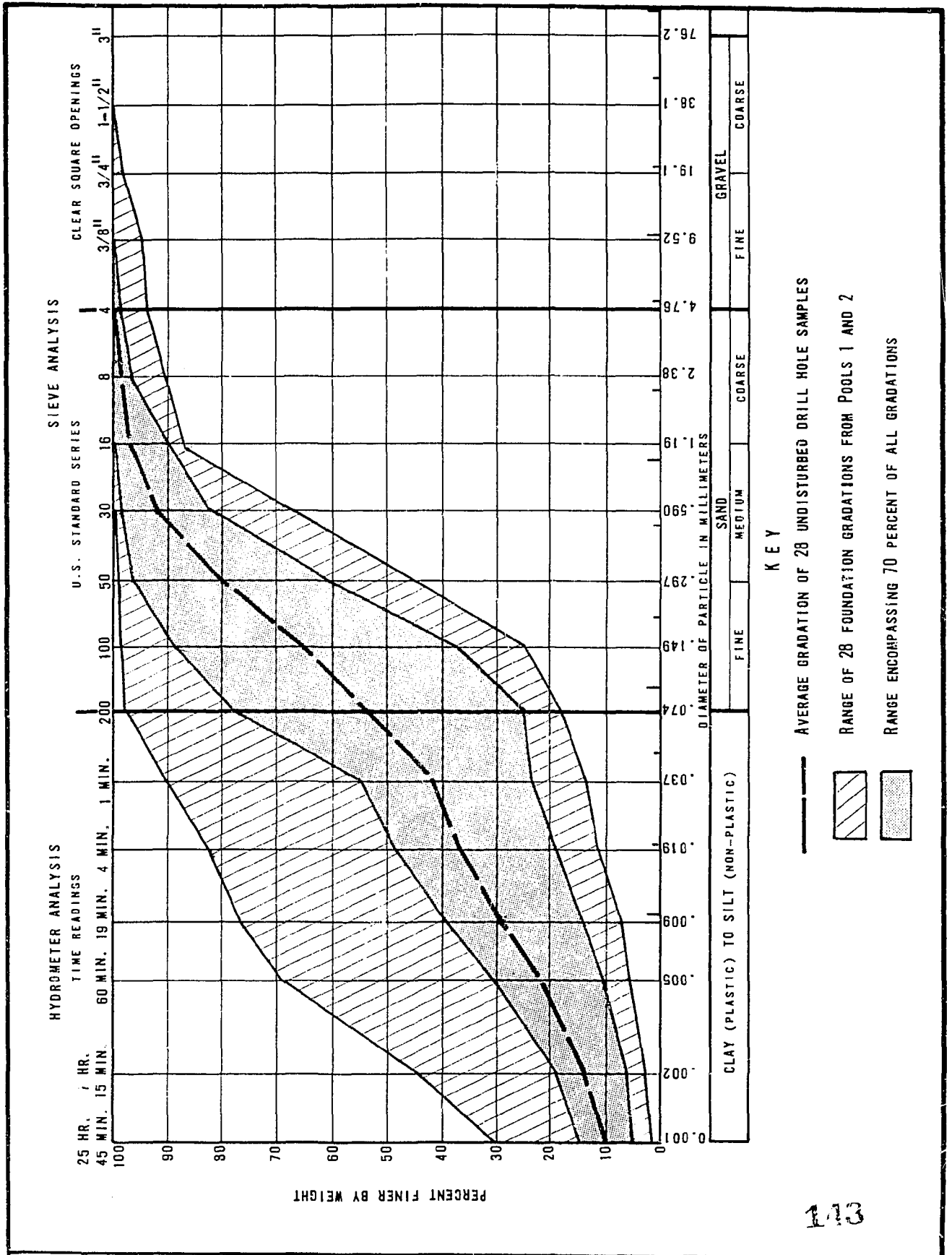

113

W. A. WAHLER & ASSOCIATES PALO ALTO • NEWPORT BEACH • CALIF	COAL REFUSE DAM FAILURE SAUNDERS, WEST VIRGINIA		GRADATION SUMMARY FOUNDATION (SLUDGE) MATERIAL		
	PROJECT NO 0700	DATE NOVEMBER 1972	DRAWING NO VII-6		

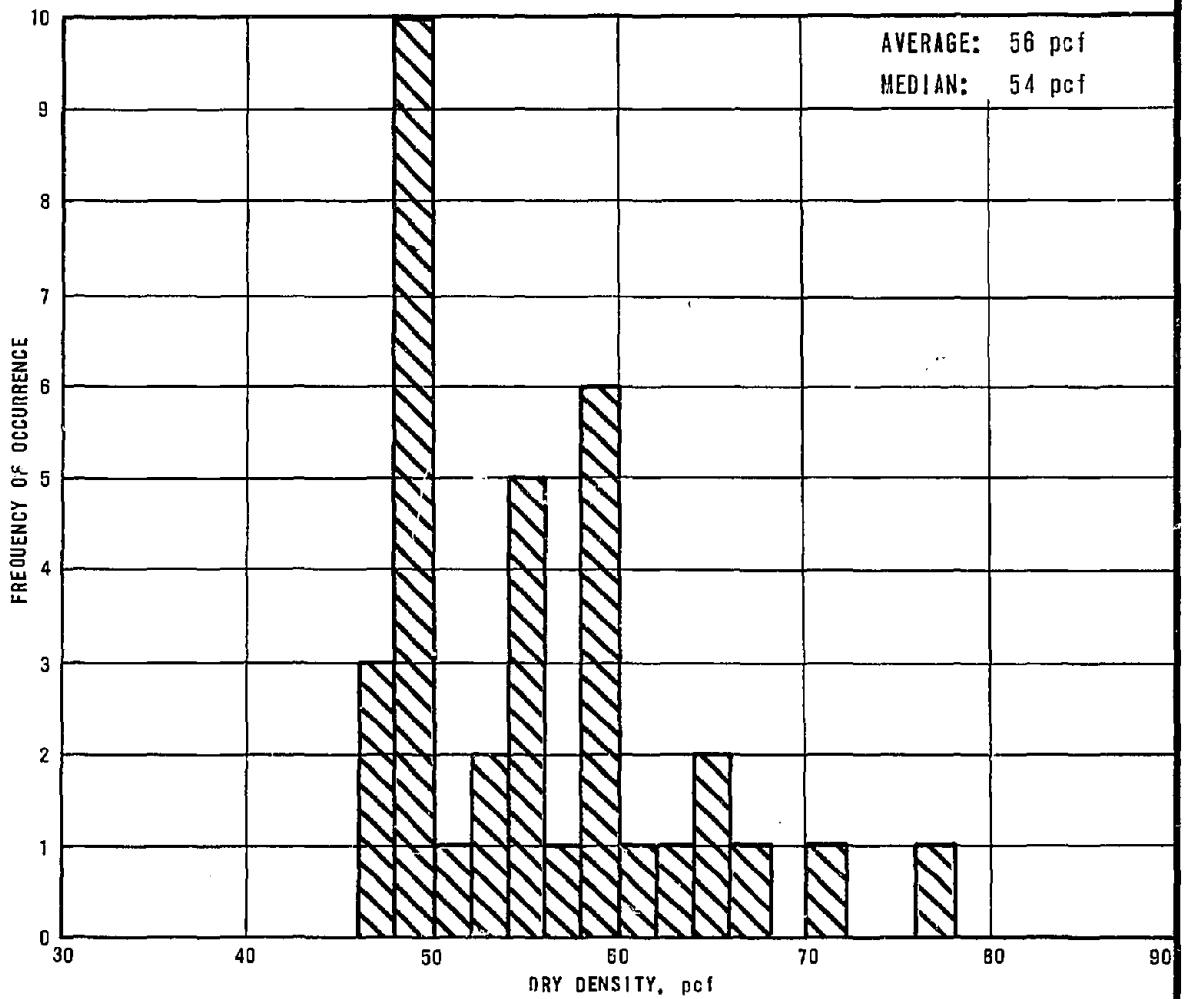

- NOTES: (1) THE DATA SHOWN HEREON, WHICH IS PRESENTED IN ITS ORIGINAL FORM IN TABLES A-2 AND B-1, REPRESENT DRY DENSITIES OF SELECTED FOUNDATION MATERIALS AS DETERMINED FROM BOTH IN-PLACE FIELD DENSITIES AND UNDISTURBED DRILL HOLE SAMPLES.
- (2) A STATISTICAL EVALUATION OF THESE DATA WAS NOT PERFORMED BECAUSE THE SAMPLE SELECTION PROCESS COULD PRECLUDE A RANDOM VARIATION OF SAMPLED DATA.
- (3) NOT INCLUDED IN THE FREQUENCY DISTRIBUTION ARE TEST RESULTS REPRESENTING DISTURBED, TRANSLATED OR MIXED MATERIALS.

111

W. A. WAHLER
& ASSOCIATES

COAL REFUSE DAM FAILURE
SAUNDERS, WEST VIRGINIA

PALO ALTO • NEWPORT BEACH • CALIF.

DRY DENSITY FREQUENCY DISTRIBUTION
FOUNDATION MATERIAL

PROJECT NO.

0700

DATE

NOVEMBER 1972

FIGURE NO.

VII-7

This test was performed in accordance with standard methods as described in Appendix B under "Compaction Tests." The ponding method of disposal utilized at this site resulted in in situ dry unit weights which compared fairly well with maximum dry unit weights attained by standard laboratory compaction methods. The relative compaction values, which express the ratio of in situ dry density to laboratory maximum dry density, averaged slightly above 90 percent and varied from about 83 to 105 percent.

Figure VII-7 illustrates the predominance of dry density values in the range of 45 to 55 pounds per cubic foot, with a median of 54 pounds per cubic foot. The proportion of coal in a sample influences the specific gravity of a material, therefore, it is reasonable to expect wide variations of in situ dry densities. Unless a laboratory maximum density test is conducted for each sample, it is possible that these variations may indicate inordinately high or low relative compaction values for any given sample. Since it was physically impossible to retrieve a sufficient quantity of material for a standard laboratory compaction test from each specific location, other methods of evaluation were considered. In situ vane shear and cone penetrometer tests were performed in an attempt to make a qualitative evaluation of the density variations in the sludge deposits. Although these methods were not completely successful, the data obtained did confirm that the sludge materials were in a relatively dense state. These in situ test methods are described and a discussion of test results presented in Appendix A.

A complete review of all collected data regarding the in situ density of the foundation sludge material indicates that this material, because of its high coal content, exhibits an abnormally low specific gravity and corresponding dry density. The low densities are not necessarily the result of the materials having been hydraulically placed. In fact,

the densities of these materials, if placed and compacted by conventional earth moving equipment, would not have been significantly higher than those obtained by hydraulic means. The low specific gravity and corresponding dry unit weight under any conditions of placement serve as a strong warning that these sludge materials are not suitable for foundation or embankment construction in situations where water impoundment, seepage or saturation may be involved unless specialized engineering design techniques are employed to maintain their stability against liquefaction and piping.

The permeability characteristics of the foundation sludge materials were determined by thoroughly evaluating the construction methods, observations at the site, and laboratory test results. This evaluation indicated that a significant degree of anisotropy was developed in the foundation sludge materials because of their method of deposition. The sludge materials were found to be highly lenticular with stratifications varying from fractions of an inch to several inches in thickness. The fine-grained silts (ML) usually constituted the thinner partings, probably as a result of short periods of time of relatively quiescent stream flow, and exhibited a coefficient of permeability of about 3×10^{-7} cm/sec, which is about 700 times more impervious than the typical embankment material. The fine- to medium-grained silty sand (SM), which constituted the coarser fraction of the foundation sludge material, had a maximum coefficient of permeability of 3×10^{-4} cm/sec, which is very nearly the same as that of the typical embankment material. Clearly then, the sludge foundation was not only significantly more impervious than the embankment, but it also consisted of layered materials for which the extreme values of permeability of themselves varied by a factor of 1,000. In conclusion, a thorough evaluation of the laboratory permeability test results, combined with judgment based on drill hole logs and visual observation of many undisturbed foundation tube samples, indicated that the most probable range for the ratio

between horizontal and vertical permeability was 25:1 to 100:1. These values are referred to later in this discussion as anisotropic foundation permeability ratios.

The shear strength characteristics of the foundation sludge were determined by conventional triaxial testing procedures as discussed in detail in Appendix B. These test results are summarized on Figure VII-8.

Development of shearing resistance in the saturated sludge materials was limited by their light unit weights, because the cohesion parameter for these nonplastic materials is either very low or nonexistent for the effective stress condition. As shown on Figure VII-8, the shear strength parameters determined by triaxial shear testing of the sludge materials are not unusually low. However, unless sufficient supplementary load is superimposed on this material to significantly increase the intergranular stress and also provide resistance to lateral deformation, the full benefit of its ability to resist shear cannot be realized because of its unusually light unit weight.

The important engineering properties for the sludge materials are summarized below.

FOUNDATION MATERIALS

<u>Engineering Property</u>	<u>Value Used in Analyses</u>
Dry Density	54 pcf
Wet Density	78 pcf
Equivalent Coefficient of Permeability ($\sqrt{k_h \times k_v}$)	2×10^{-5} cm/sec
Permeability Ratio (Horizontal to Vertical)	25:1 and 100:1
Specific Gravity	1.43
Shear Strength Parameters	
Effective Stress	$\phi' = 37^\circ$ $C' = 0$
Total Stress	$\phi = 16.5^\circ$ $C = 1100$ psf

147

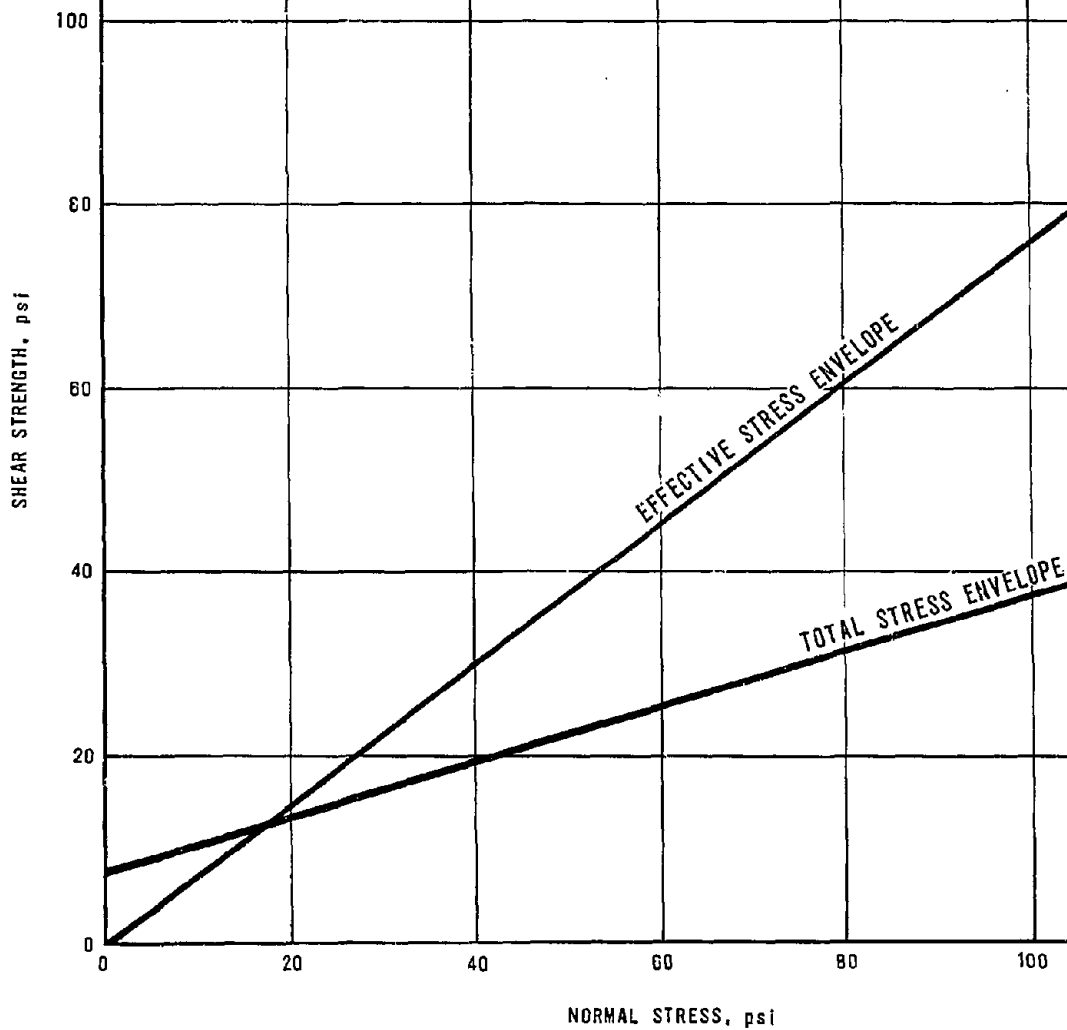

EFFECTIVE STRESS PARAMETERS

$\phi^t = 37^\circ$
 $c^t = 0$

TOTAL STRESS PARAMETERS

$\phi = 16.5^\circ$
 $C = 7.5 \text{ psi} = 1.1 \text{ ksf}$

- NOTES (1) THE ENVELOPES SHOWN REPRESENT THE AVERAGE SHEAR STRENGTH CHARACTERISTICS OF 16 UNDISTURBED SAMPLES.
 (2) SEE APPENDIX B FOR DETAILED RESULTS

C. CLIMATOLOGICAL DATA

Pertinent to this investigation was an evaluation of the weather conditions in southwestern West Virginia and the vicinity of Middle Fork Valley prior to the Buffalo Creek Flood. Rainfall in the region, as interpreted from National Weather Service information, is depicted on Figure VII-9. There is no official weather reporting station located in the immediate vicinity of the Middle Fork of Buffalo Creek. Using Lorado, West Virginia as a central point on Buffalo Creek, the following U.S. Department of Commerce stations can be located:

1. Logan, West Virginia 15.5 miles west
2. Madison, West Virginia 18.0 miles north-northwest
3. Pineville, West Virginia 17.5 miles south-southeast

The detailed climatological data reported by these three weather stations for the period from January 1 to February 29, 1972 are contained in Appendix C in Table C-2, Daily Weather Conditions, and Table C-3, Summary.

The rainfall for February, while above normal, was not of an unusual amount for this area. As shown on Figure VII-9, the rainfall at Saunders in the 48 hours preceding the flood probably amounted to 3½ inches. A field survey of open containers by the U.S. Geological Survey in the week following the flood found no open containers which contained more than the 3.7 inches of rain recorded at Logan, West Virginia (Davies and others, 1972b). In addition, indirect measurements by USGS personnel of Buffalo Creek tributaries indicate that there were no high flows in these streams such as would be produced by a local rainfall of extreme intensity.

From studies of these climatological data and related information, several conclusions can be drawn:

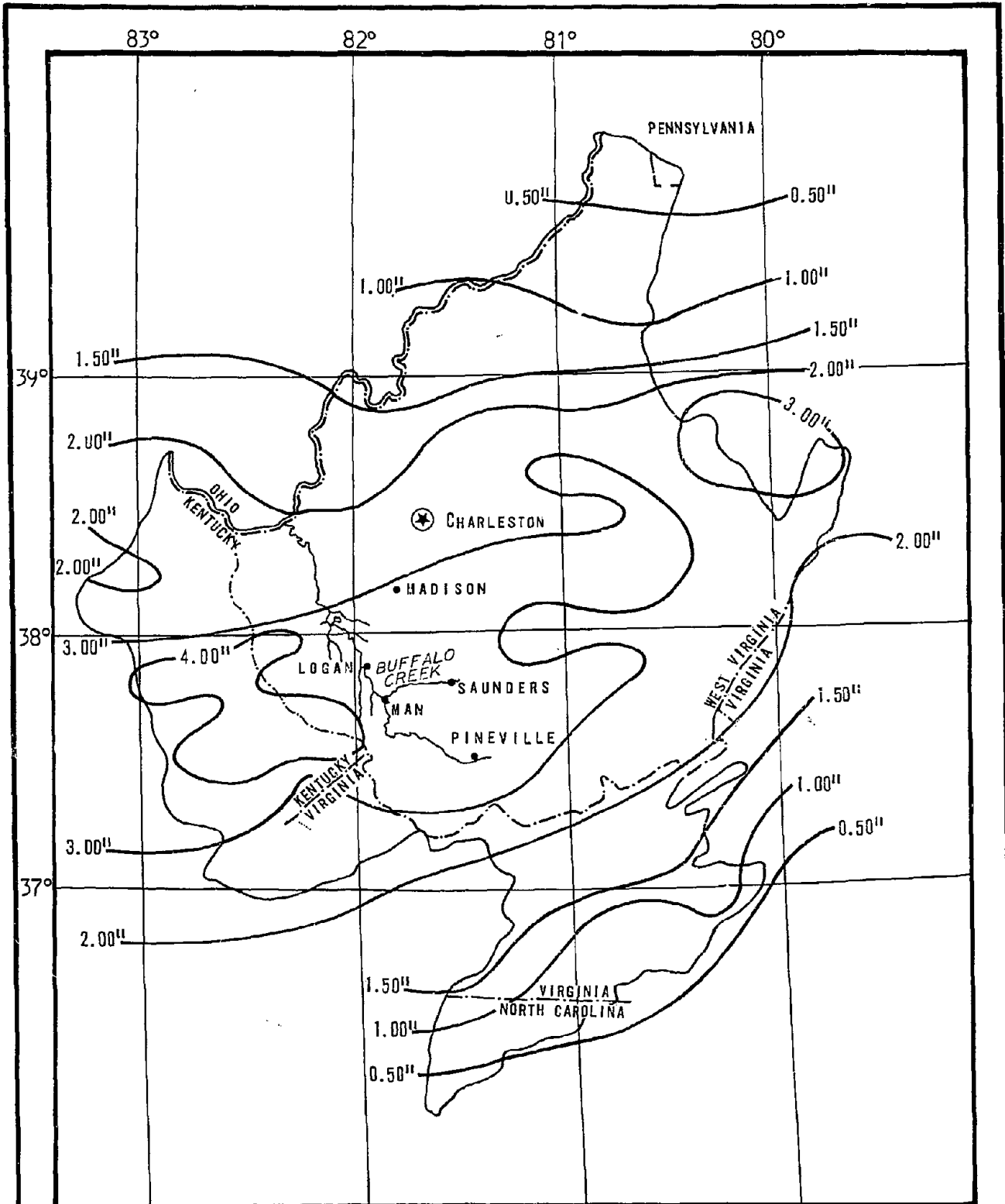

INFORMATION FROM NATIONAL WEATHER SERVICE DATA.

SCALE

150

20 0 20 40 MILES

W.A. WAHLER & ASSOCIATES

COAL REFUSE DAM FAILURE
SAUNDERS, WEST VIRGINIA

RAINFALL IN SOUTHWESTERN WEST VIRGINIA
FROM 7:00 A.M. ON FEB. 24 TO 7:00 A.M., FEB. 26

PROJECT NO.

DATE

DRAWING NO.

PALO ALTO • NEWPORT BEACH • CALIF.

0700

NOVEMBER 1972

VII-9

1. The rainfall was widespread and rather evenly distributed within at least a 20-mile radius of the dam site during the two-day period preceding the dam failure.
2. The temperature and precipitation records for the six-day period preceding the failure indicate that probably little or no snow would have been on the ground during the two-day period preceding the dam failure.
3. The same records cited in (2) above also indicate that it is highly improbable that any ice had formed on, or accumulated within, the downstream face of the dam preceding failure.
4. The storm of February 24-26 had a magnitude to be expected approximately every two years. National Weather Service data indicate that 3.7 inches of rain in a two- to three-day period has occurred eight times in the last 17 years (Davies and others, 1972b).
5. Based on observations at Logan, the total precipitation at Saunders during the two-month period preceding the dam failure was at least five inches greater than the normal amount of 7.3 inches.
6. In the absence of heavy snow cover or snow melt, and considering the not too unusual amount of local rainfall and the lack of flooding on other local streams, it is concluded that the magnitude of the Buffalo Creek Flood was due solely to the water released by the failure of Dam No. 3 on the Middle Fork near Saunders.

D. RESERVOIR CONDITIONS

The condition and level of the reservoirs behind Dams 1, 2, and 3 on the day of failure have been reconstructed by thoroughly reviewing the January and February rainfall records for Logan County and eyewitness accounts of visits to the site. These data were utilized, along with

data of the surrounding watershed area and capacities of the reservoirs, to determine the probable pool conditions prior to failure. Of importance for evaluating the failure on February 26, 1972 are the crest levels of Dams 2 and 3, in particular, and, to some extent, the crest level of Dam No. 1. Prior to the time of failure, the minimum crest levels of Dams 1, 2, and 3 were at approximately Elevations 1,658, 1,690 and 1,753, respectively.

Other significant factors regarding reservoir conditions include normal water levels in Pools 2 and 3, variations of these levels, and the seepage through the dams. As discussed previously, preparation plant water discharged upstream of Pool 4 during normal operations amounted to approximately 300,000 gallons per day. This water, which carried about 200 tons of sludge a day, flowed through the reservoir of Pool 4 and entered Pool 3. These wastes, combined with normal precipitation, resulted in a relatively steady water level in the pools; in Pool 3 the water level was generally at about Elevation 1,735 (perhaps higher in the winter months) and in Pool 2 at about Elevation 1,685.

Surface runoff which would have otherwise flowed from surrounding hillsides directly into Pools 1, 2, and 3 was intercepted by ditches constructed along the uphill sides of mining roads near the pools. Normally, the ditch along the road on the left side of the valley discharged into a pond area near the upstream end of the refuse bank. During the February 24-26 storm, this discharge had little effect on the dams. Although the ditch along the No. 5 Mine Road on the right side of the valley was not designed or constructed as an adequate diversion system for the dam complex, it performed several useful functions:

1. it intercepted downslope runoff;
2. downstream of the right abutment of Dam No. 2, it accepted discharge from the Dam No. 2 overflow pipe;
3. downstream of the right abutment of Dam No. 1, it accepted discharge from the Dam No. 1 overflow pipes; and,
4. it carried these flows to the discharge culverts that led under the No. 5 Mine Road.

The above features are shown on the diagrammatic sketch, Figure V-19. The postfailure map, Figure VI-20, shows stream alluvium covering the No. 5 Mine Road at two locations: at the right abutment of Dam No. 2, and just upstream of the right abutment of Dam No. 1. The alluvial deposits, referred to as "slides" in the testimony, blocked the ditch and diverted its flow. These "slides" are actually alluvial fans deposited at locations where the stream gradient decreases abruptly. There are no large slide scarps or obvious slide source areas above the alluvial fans, and they do not include significant amounts of slide debris. Elsewhere along the haul roads, slides did indeed occur.

Our interpretation of the available testimony is that the lower "slide," which covered the No. 5 Mine Road above the right abutment of Dam No. 1, was the one causing initial concern. It was to this "slide" that the equipment operators were first directed. The "slide" was blocking the ditch and diverting its flow into Pool 1. Since the "slide" was cleared, the mapped alluvial patch is largely a postfailure deposit. The diversion of ditch water into Pool 1 may have raised that pool significantly, since testimony indicates that Pool 1 nearly overtopped Dam No. 1 when one of the outlet pipes was blocked. However, the outlet pipes were apparently sufficient to keep the pool from overtopping the dam when both were clear of obstructions.

Neither the field evidence nor the testimony make clear the timing, extent, or effects of the "slide" which covered the No. 5 Mine Road

above the right abutment of Dam No. 2. It may have at times diverted water into Pool 2, onto the crest of Dam No. 2, or down the right downstream groin of Dam No. 2 and into Pool 1. Water diverted into Pool 2 would, of course, raise the pool level and put an additional demand on the outlet pipe through Dam No. 2. Water diverted onto the crest of Dam No. 2 or down the groin would tend to erode the dam. As discussed elsewhere in this Chapter, we do not believe that this action caused Dam No. 2 to fail before Dam No. 3. However, erosion in the right abutment area of Dam No. 2 may have weakened that area so that the dam was more susceptible to breaching.

No attempt was made to reconstruct the rise in reservoir level from the normal pool at Elevation 1,735 to the flood stage at Elevation 1,753 because of the complete lack of detailed rainfall records in close proximity to the Middle Fork area. However, an attempt is made, as discussed below, to reconstruct the rise of the reservoir surface during the 40-hour period preceding failure using the testimony of Buffalo Creek Mining Company personnel.

Based on eyewitness accounts, the water level behind Dam No. 3 was well above normal pool Elevation 1,735 on February 22, 1972. During the morning hours of this day, the Buffalo Mining Company became aware of high water level behind Dam No. 3 when Mr. D. S. Dasovich visited the area to observe the condition of the roads to the various company mines, and while doing so drove onto the embankment (Hearings Transcript of the West Virginia Ad Hoc Commission, 1972b). The water level behind Dam No. 3 was then two to three feet below the 24-inch spillway pipe, according to Mr. Dasovich. This pipe is reported to have been seven to eight feet below the graded crest according to the Hearings Transcript, and four to seven feet below the crest according to Davies and others (1972b). However, it is not clear whether these depths are to the invert level or the top of the pipe. The reconstructed configuration of Dam No. 3 indicates that the upstream shoulder of the

embankment at the pipe location was probably near Elevation 1,752, or approximately one foot lower than the lowest point of the crest near the center of the dam. Based on these sources, therefore, the upstream invert of the spillway pipe may have ranged between Elevation 1,748 to 1,742. We have assumed the upstream invert to be approximately at Elevation 1,745, as discussed below.

On Thursday, February 24, Mr. Dasovich observed water flowing from the downstream end of the 24-inch spillway pipe and that the water level in Pool 3 had risen two to three feet since his previous visit on February 22. On the same date, Mr. Jack Kent, Strip Mining Superintendent, Buffalo Mining Company, observed the water level rising behind Dam No. 3, and that at 1600 hours it was about five feet below the graded crest of the dam and above the spillway pipe. Based on these statements, it is estimated that the invert level of the pipe was at approximately Elevation 1,745. Thus, it is expected that the spillway pipe at Dam No. 3 carried a full flow for at least 40 hours prior to the failure.

At the time of Mr. Kent's observation, he placed a stick measuring 3 feet 9 inches long into the upstream face above the opening of the 24-inch overflow pipe. The top of the stick was reported to have been about one foot below the top (Elevation 1,752) of the graded crest. Table VII-1 summarizes our interpretation of the rise of the water level in Pool 3 during the 40-hour period preceding failure, based on testimonies by Messrs. Dasovich, Kent, Gibson and Goodman.

Based largely on testimony by Mr. Kent, a curve showing our interpreted rise of the water level in Pool 3 versus time was developed and is depicted on Figure VII-10. As shown thereon, the water level rose from Elevation 1,748 to Elevation 1,751 at about one inch per hour during the first 35-hour period following installation of Mr. Kent's measuring stick. Thereafter, the rate of rise increased significantly

TABLE VII-1
RESERVOIR LEVEL RISE FOR POOL 3

DATE	TIME	EVENTS	RATE OF RISE (INCHES/HR.)	APPROXIMATE * DEPTH BELOW GRADED CREST (INCHES) (ELEVATION 1752)	INFORMATION** SOURCE
FEB. 22	A.M.	GENERAL INSPECTION	--	110-120	MR. DASOVICH
FEB. 24	P.M.	OBSERVED WATER COMING THROUGH DRAINPIPE.	--	--	MR. DASOVICH
FEB. 24	1600	MEASURING STICK PLACED	--	48	MR. KENT
FEB. 25	1600	WATER LEVEL OBSERVATION	1	30	MR. KENT
FEB. 25	LATE P.M.	BEGAN RAINING VERY HEAVILY.	--	--	MR. KENT
FEB. 25	2100	WATER LEVEL OBSERVATION	1	25	MR. KENT
FEB. 26	0330	WATER LEVEL OBSERVATION	2	18	MR. KENT
FEB. 26	0430	WATER LEVEL OBSERVATION	3	15	MR. KENT
FEB. 26	0600	LONGITUDINAL CRACKS ACROSS THE FRONT OF DAM NEAR THE LEFT ABUTMENT, WATER SUR- FACE ABOVE MEASURING STICK.	--	LESS THAN 12	MR. DASOVICH
FEB. 26	0750	WATER "DOZING" THROUGH LOOSE REFUSE PILES ON TOP OF DAM. LARGE CRACKS AND SLUMPS ON DOWNSTREAM FACE OF DAM NO. 3 NEAR THE CENTER OF THE DAM.	--	LESS THAN 12	MR. GIBSON

* GRADED CREST IN THE AREA OF THE MEASURING STICK WAS ESTIMATED TO BE AT ELEVATION 1752 OR APPROXIMATELY ONE FOOT BELOW MINIMUM CREST ELEVATION.

** SEE TABLE C-4 FOR REFERENCE.

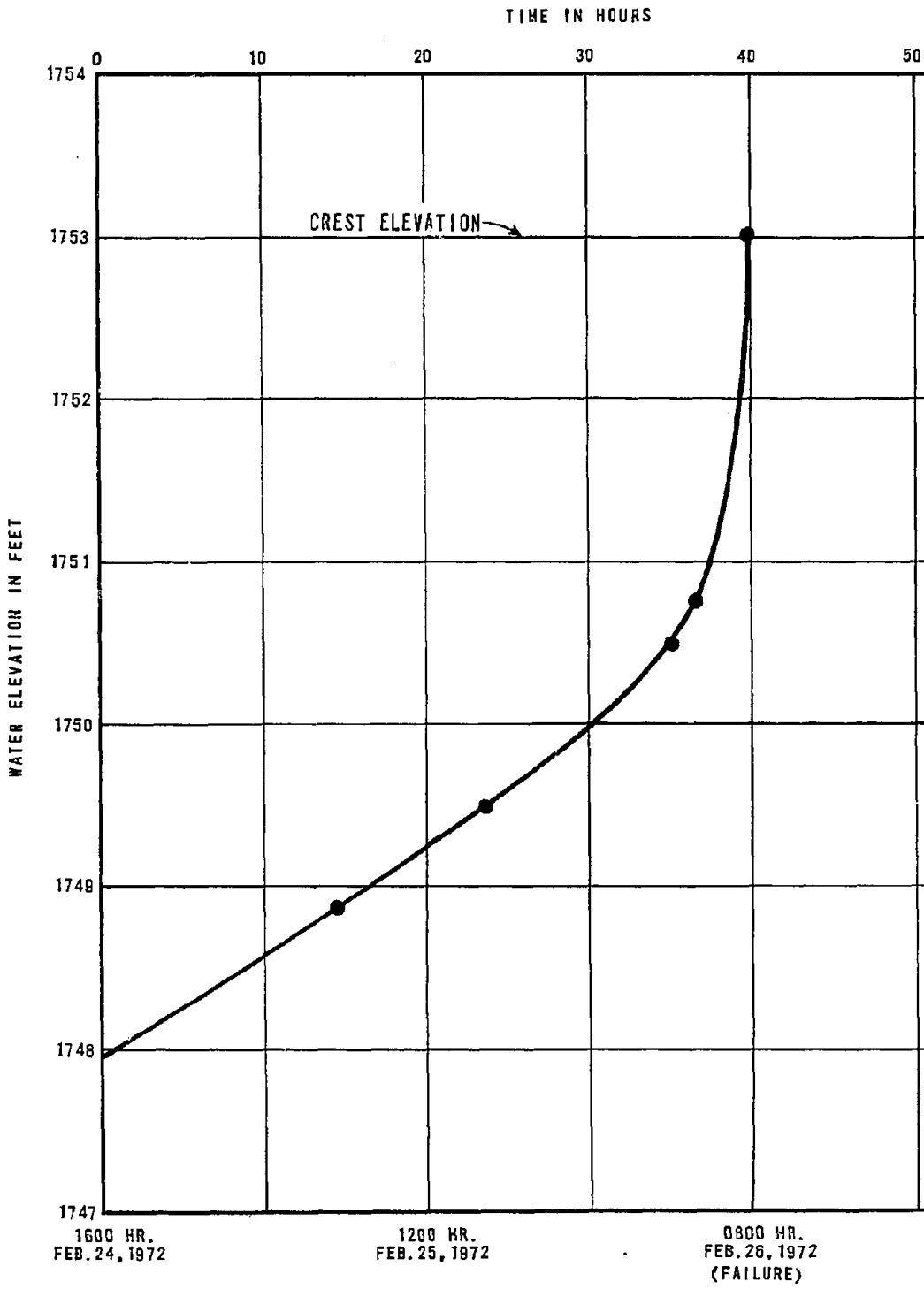

KEY
 ● DATA POINTS FROM TABLE VII-1

157

W. A. WAHLER & ASSOCIATES	COAL REFUSE DAM FAILURE SAUNDERS, WEST VIRGINIA	APPARENT WATER LEVEL RISE VS TIME POOL 3 (BASED ON MR. KENT'S TESTIMONY)		
		PROJECT NO. 0700.	DATE NOVEMBER 1972	FIGURE NO. VII-10

PALO ALTO • NEWPORT BEACH • CALIF.

and most likely resulted in the water reaching its highest level of Elevation 1,753 just prior to failure at about 0800 hours on February 26, 1972. The significance of this reservoir rise and the probability of overtopping are discussed later in this Chapter.

E. FAILURE ANALYSES

Although numerous visits to the impoundment area were made by Buffalo Mining Company personnel during the four-day period preceding failure, there were no eyewitness accounts of the actual failure. The testimony regarding these visits, which is presented in chronological order in Table C-4 of Appendix C, contains several conflicting statements regarding the condition of the embankments prior to failure; however, the bulk of this testimony was critically reviewed to insure that the time element of the failure, as recreated herein, was compatible with witnesses' observations. To recreate the probable mode or modes of failure, a number of engineering analyses were performed to determine the mode most compatible with the extensive data obtained from the field and laboratory investigations.

The complete absence of drawings showing the prefailure embankment configuration was a significant handicap for the analyses discussed herein. Although the thickness of the foundation sludge material was reasonably well defined by the exploratory drilling program, it was necessary to reconstruct the embankment configuration of Dam No. 3 from a detailed assessment of field and laboratory data developed during the course of our investigation and a review of the prefailure aerial photographs of the Middle Fork Valley. The two embankment sections used for the detailed engineering analyses are shown in plan on Figure VII-11 and in transverse section on Figures VII-12 and VII-13. As shown on the longitudinal section, Figure VI-22, the thickness of foundation sludge upon which the central 270 feet of Dam No. 3 was

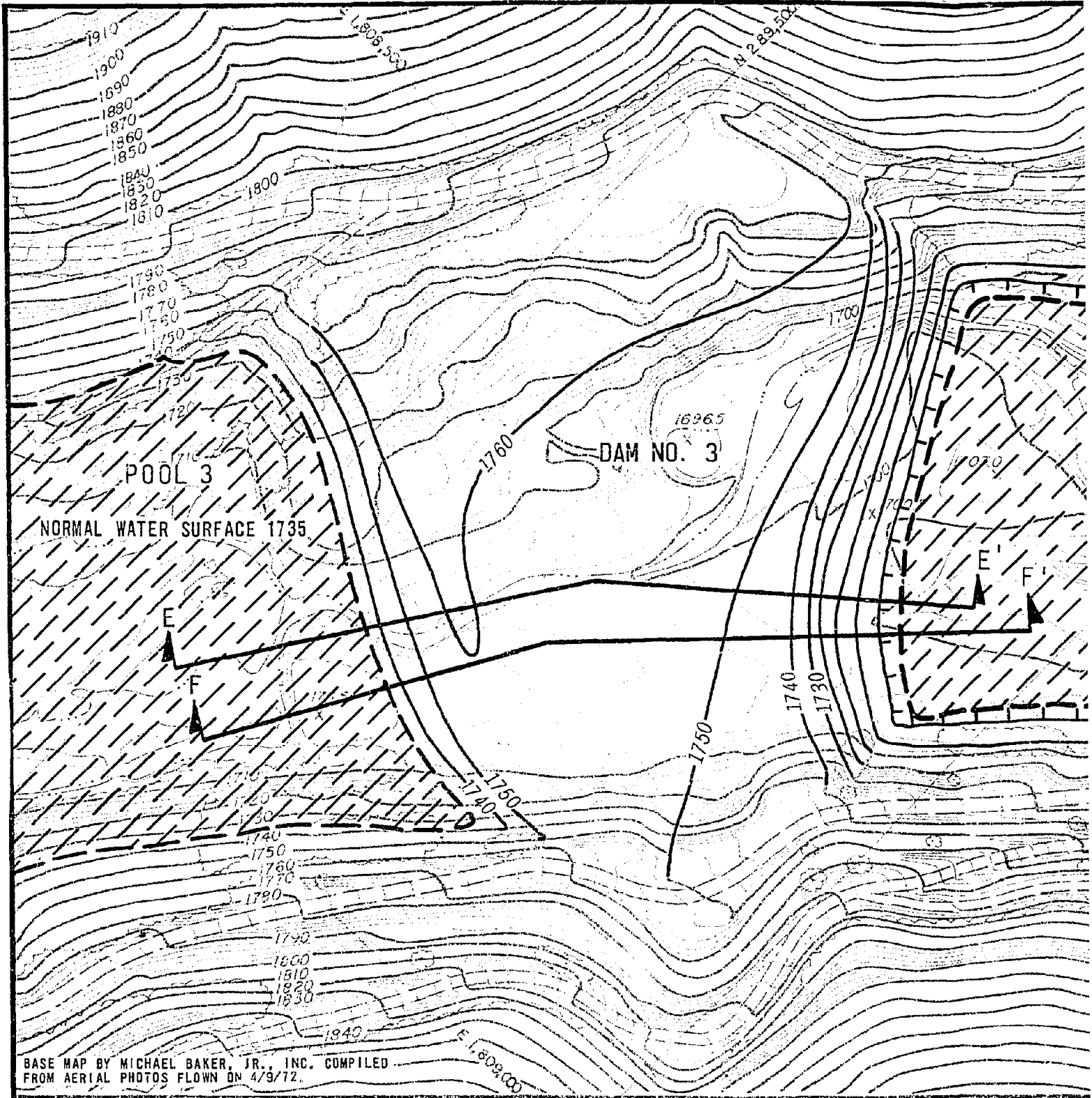

- NOTES: (1) PREFAILURE TOPOGRAPHY CONSISTS OF 10' CONTOURS AND SELECTED 2' CONTOURS IN THE DAM NO. 2 AREA.
- (2) RECONSTRUCTED PREFAILURE TOPOGRAPHY IS BASED ON POSTFAILURE TOPOGRAPHIC CONFIGURATION AND OTHER AVAILABLE DATA. SEE FIGURE V-16.
- (3) SEE FIGURE VII-12 FOR SECTION E-E'.
- (4) SEE FIGURE VII-13 FOR SECTION F-F'.

KEY

- RECONSTRUCTED PREFAILURE TOPOGRAPHY.
- - - POSTFAILURE TOPOGRAPHY.
- ▲ LINE OF SECTION.

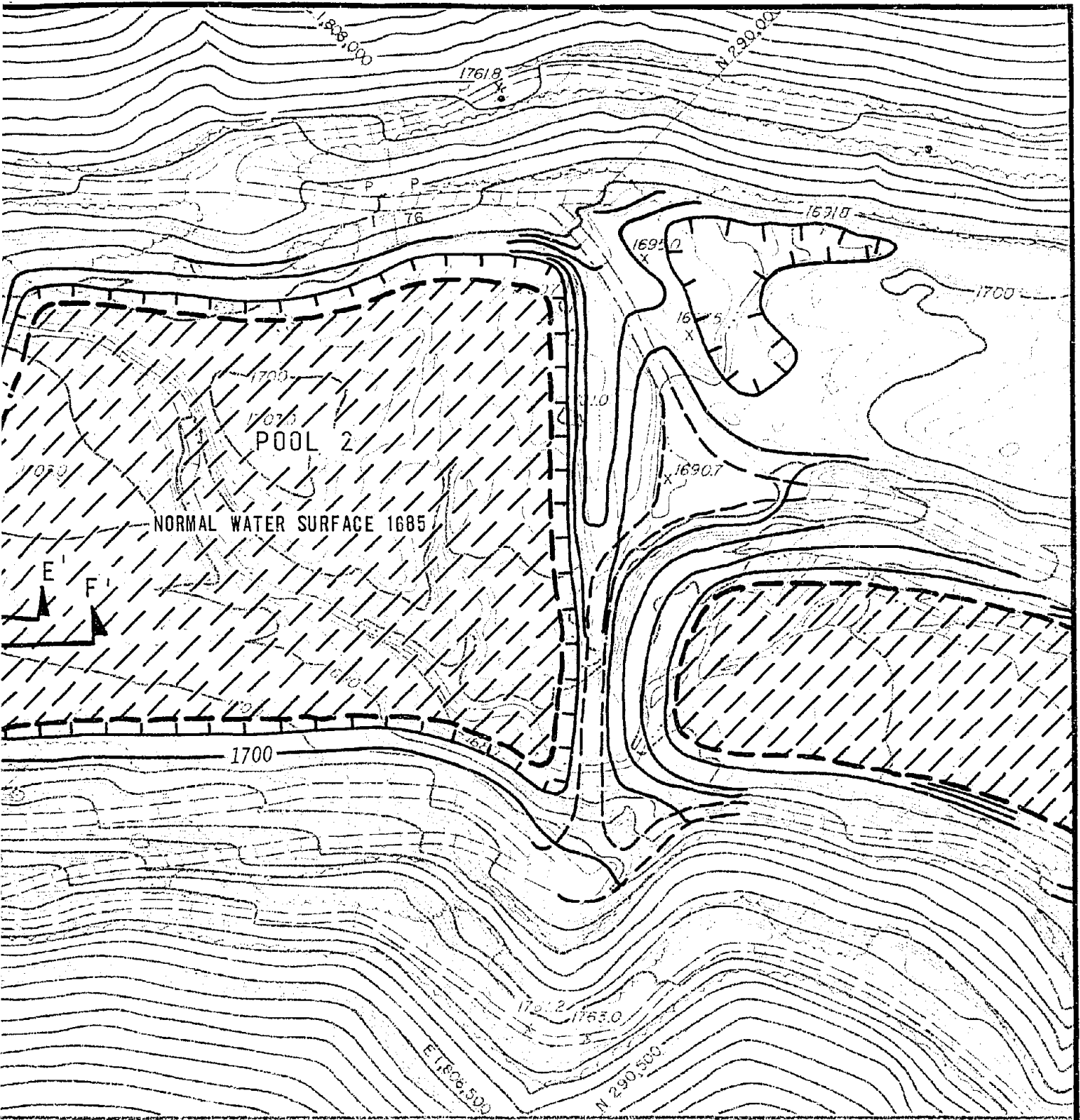

SCALE
 100 0 100 FEET
 MAIN CONTOUR INTERVAL 10 FEET

159

REFAILURE

TOPOGRAPHY.

W.A. WAHLER & ASSOCIATES PALO ALTO • NEWPORT BEACH • CALIF.	COAL REFUSE DAM FAILURE SAUNDERS, WEST VIRGINIA		LOCATION OF SECTIONS USED IN ENGINEERING ANALYSES	
	PROJECT NO. 0730	DATE NOVEMBER 1972	FIGURE NO. VI-1	

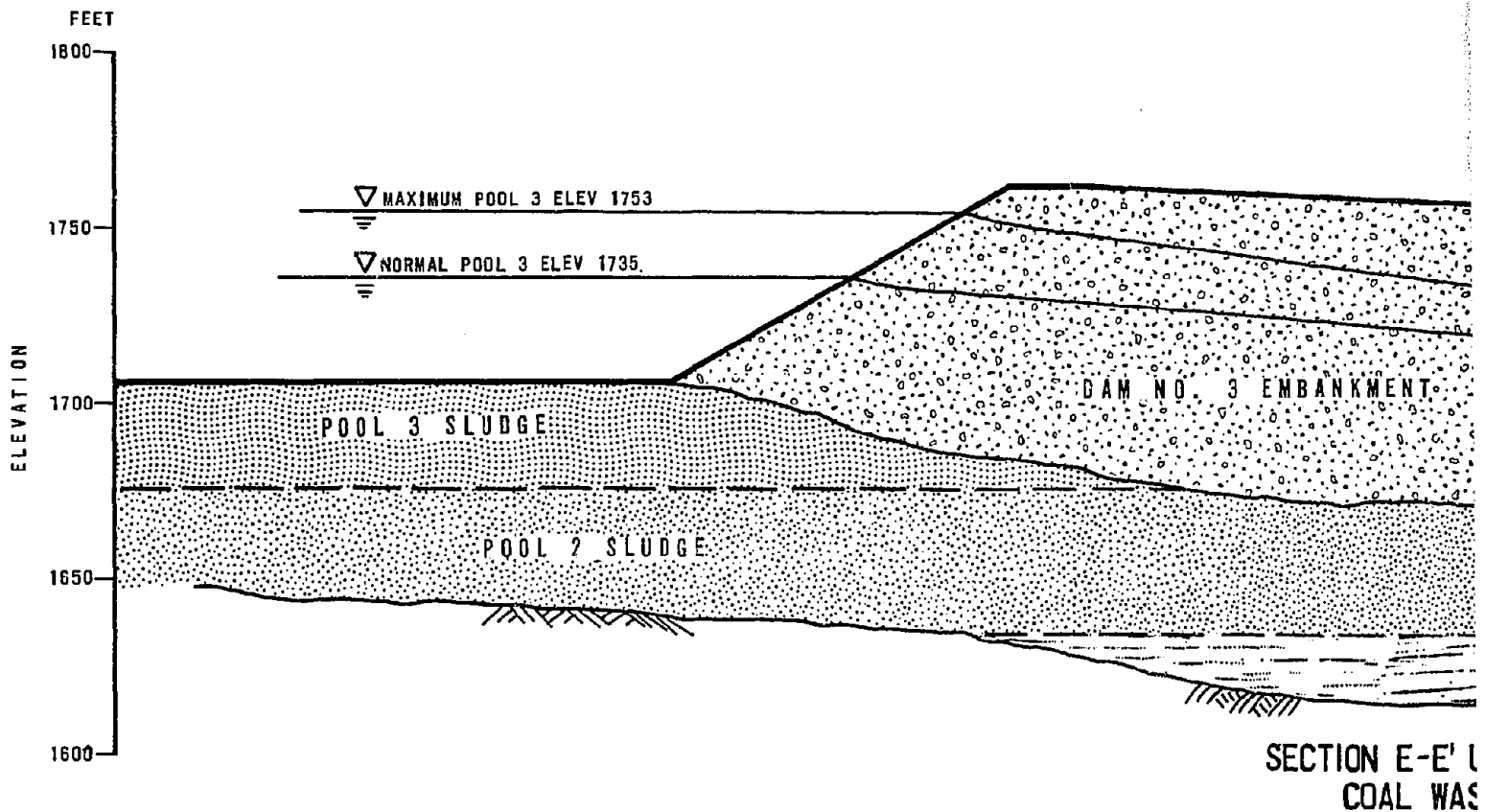

SECTION E-E' L
COAL WAS

SOIL PROPERTIES USED IN STABILITY ANALYSIS

MATERIAL TYPE	MATERIAL DISCIPTION	UNIT WEIGHTS (pcf)		SHEAR STRENGTH PAR		
		DRY	SATURATED	EFFECTIVE STRESS		T
				ϕ'	c' (ksf)	ϕ
EMBANKMENT	GRAVELLY, SLIGHTLY SILTY SAND (COARSE COAL WASTE)	90(2)	106(2)	$\bar{\sigma}_n \leq 2.3$ ksf 41.0°	0	17.
				$\bar{\sigma}_n > 2.3$ ksf 34.0°	0.5	17.
FOUNDATION	SANDY SILT AND SILTY SAND (FINE POOL SEDIMENTS)	54	78	37.0°	0	16.
BEDROCK	SANDSTONES, SHALES & COAL SEAMS OF THE KANAWHA SERIES	--	--	(3)	(3)	(3)

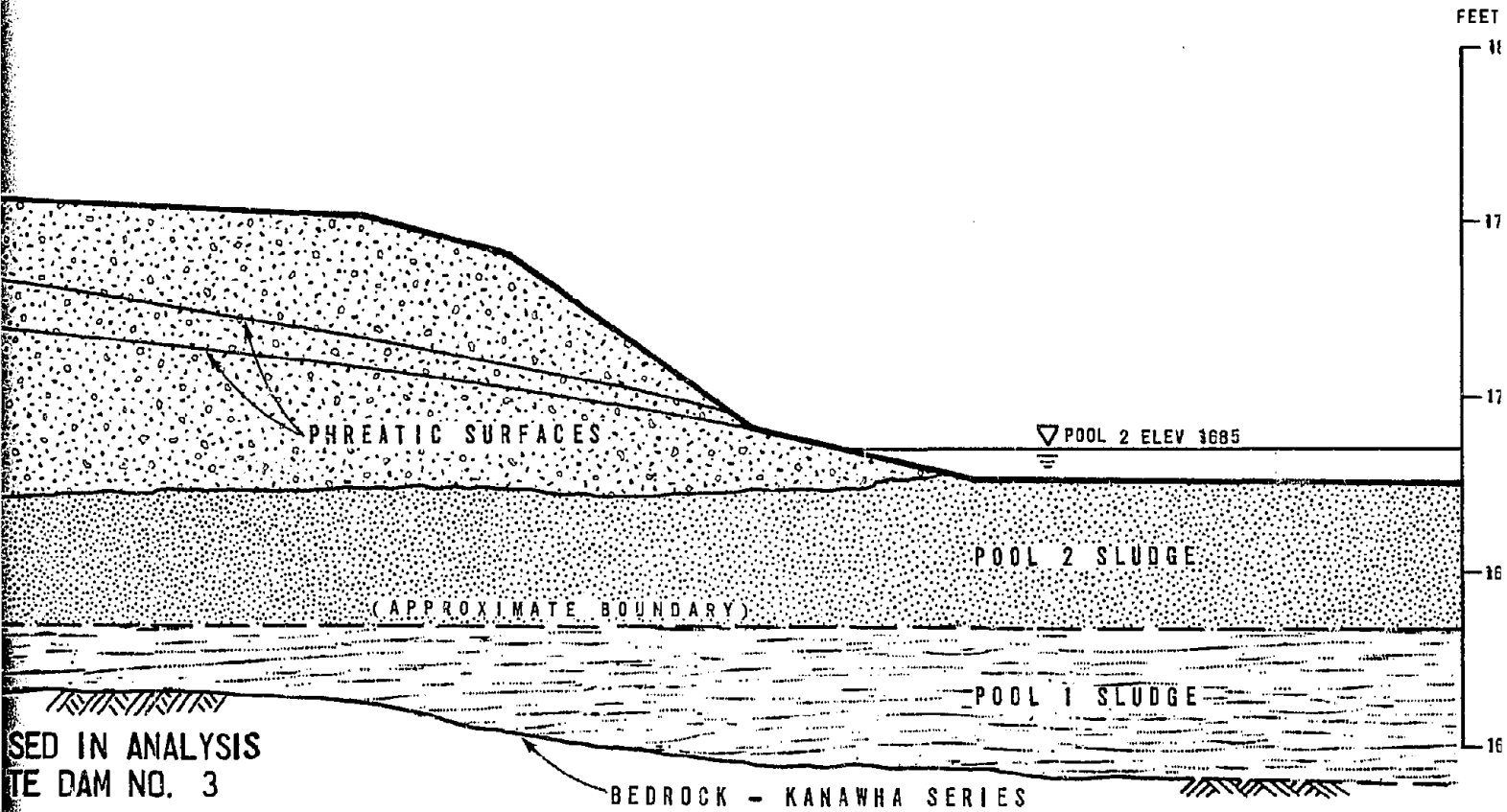

METERS	
TOTAL STRESS	
	C (ksf)
0.0	0.7
0.5	0.7
1.0	1.1
1.5	(3)

- NOTES:
- (1) SECTION E-E' IS LOCATED SLIGHTLY RIGHT (LOOKING DOWNSTREAM) OF THE DAM MID-SECTION AS SHOWN IN FIGURE VII-17.
 - (2) MOIST UNIT WEIGHTS OF THE EMBANKMENT MATERIALS WERE ASSUMED TO VARY FROM 96 pcf AT THE CREST OF THE DAM TO 106 pcf BELOW THE PHREATIC SURFACE.
 - (3) INFINITELY HIGHER STRENGTHS WERE ASSUMED FOR THE BEDROCK MATERIAL AND ALL FAILURE SURFACES WERE ASSUMED TO BE CONFINED TO THE EMBANKMENT AND SLUDGE MATERIALS.
 - (4) PORE PRESSURES ASSUMED FOR THE STABILITY ANALYSIS WERE DETERMINED FROM APPLICABLE FLOW NETS (SEE FIGURES VII-16, VII-17, AND VII-20).
 - (5) PATTERNS USED FOR THE SLUDGE MATERIAL OF POOLS 1, 2, AND 3 AS WELL AS THE EMBANKMENT MATERIAL OF DAM NO. 3 ARE FOR DELINEATION ONLY AND ARE NOT MEANT TO SUGGEST TEXTURE OR COMPOSITION.

W. A. WAHLER & ASSOCIATES	COAL REFUSE DAM FAILURE
	SAUNDERS, WEST VIRGINIA
PALO ALTO • NEWPORT BEACH • CALIF.	

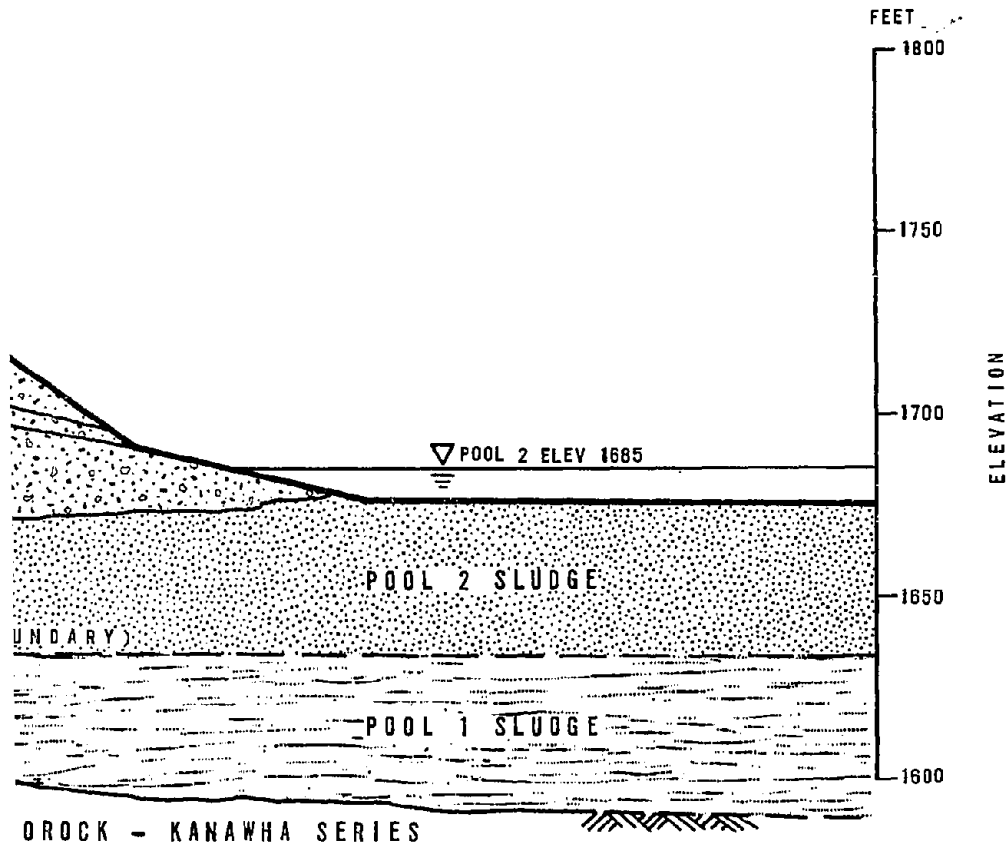

LOCATED SLIGHTLY RIGHT
 (AM) OF THE DAM MID-
 IN FIGURE VII-11.

S OF THE EMBANKMENT
 SUMED TO VARY FROM
 ST OF THE DAM TO
 PHREATIC SURFACE.

STRENGTHS WERE ASSUMED
 MATERIAL AND ALL FAILURE
 SUMED TO BE CONFINED TO
 D SLUDGE MATERIALS.

SUMED FOR THE STABILITY
 DETERMINED FROM APPLICABLE
 FIGURES VII-16, VII-17,

THE SLUDGE MATERIAL
 D 3 AS WELL AS THE
 AL OF DAM NO. 3 ARE
 VLY AND ARE NOT MEANT
 E OR COMPOSITION.

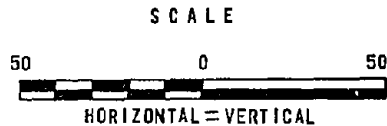
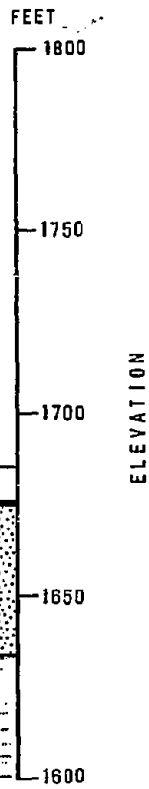

160

W. A. WAHLER
 & ASSOCIATES

COAL REFUSE DAM FAILURE
 SAUNDERS, WEST VIRGINIA
 PALO ALTO • NEWPORT BEACH • CALIF.

SECTION E-E' USED IN ANALYSIS COAL WASTE DAM NO. 3		
PROJECT NO.	DATE	FIGURE NO.
0700	NOVEMBER 1972	VII-12

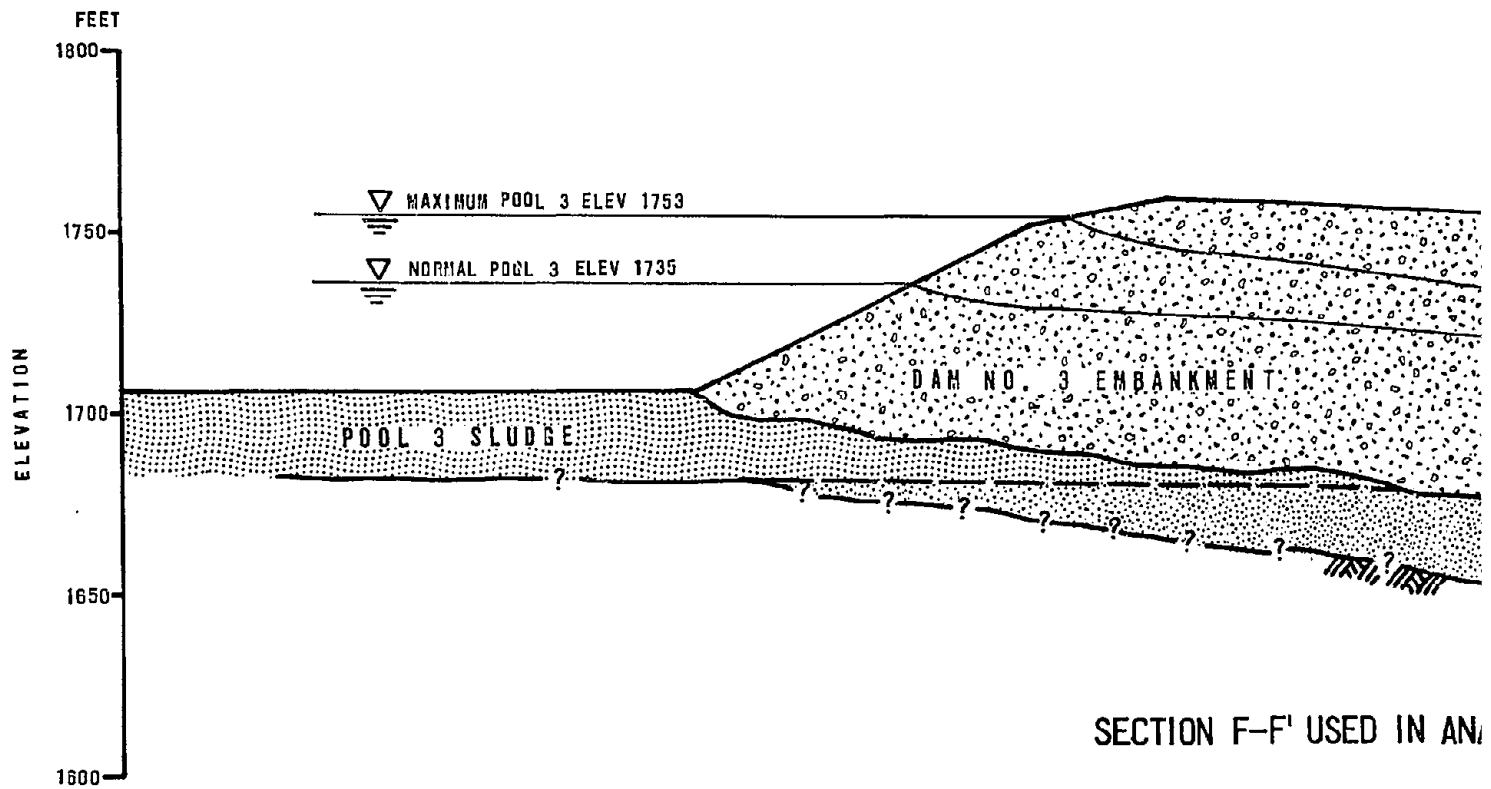

SOIL PROPERTIES USED IN STABILITY ANALYSIS.

MATERIAL TYPE	MATERIAL DESCRIPTION	UNIT WEIGHTS (pcf)		SHEAR STRENGTH	
		DRY	SATURATED	EFFECTIVE STRESS	
				ϕ^i	c^i (ksf)
EMBANKMENT	GRAVELLY, SLIGHTLY SILTY SAND (COARSE COAL WASTE)	90(2)	106(2)	$\bar{\sigma}_n \leq 2.3$ ksf 41.0°	2.3
				$\bar{\sigma}_n > 2.3$ ksf 34.0°	0.5
FOUNDATION	SANDY SILT AND SILTY SAND (FINE POOL SEDIMENTS)	54	78	37.0°	0
BEDROCK	SANDSTONES, SHALES & COAL SEAMS OF THE KANAWHA SERIES	--	--	(3)	(3)

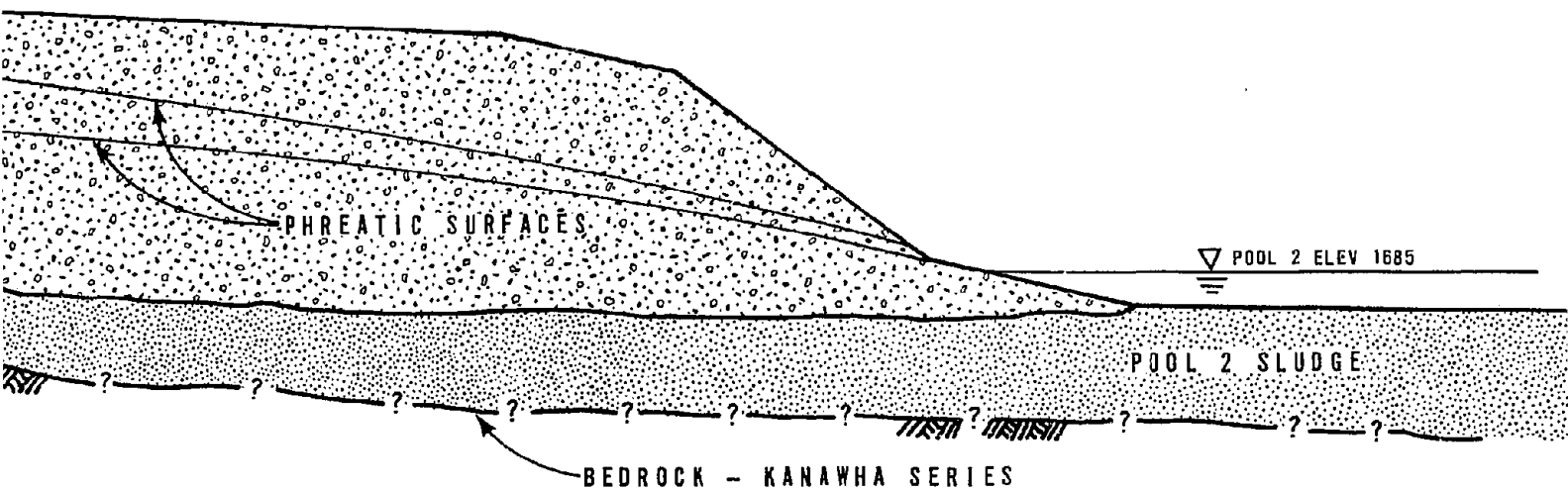

ANALYSES - COAL WASTE DAM NO. 3

STRENGTH PARAMETERS		
SS	TOTAL STRESS	
	ϕ	C (ksf)
sf	17.0°	0.7
sf	17.0°	0.7
j	16.5°	1.1
)	(3)	(3)

NOTES:

- (1) SECTION F-F' IS LOCATED RIGHT (LOOKING DOWNSTREAM) OF THE DAM MIDSECTION AS SHOWN IN FIGURE VII-11.
- (2) MOIST UNIT WEIGHTS OF THE EMBANKMENT MATERIALS WERE ASSUMED TO VARY FROM 96 pcf AT THE CREST OF THE DAM TO 106 pcf BELOW THE PHREATIC SURFACE.
- (3) INFINITELY HIGHER STRENGTHS WERE ASSUMED FOR THE BEDROCK MATERIAL AND ALL FAILURE SURFACES WERE ASSUMED TO BE CONFINED TO THE EMBANKMENT AND SLUDGE MATERIALS.
- (4) PORE PRESSURES ASSUMED FOR THE STABILITY ANALYSIS WERE DETERMINED FROM APPLICABLE FLOW NETS. (SEE FIGURES VII-18, VII-19 AND VII-20).
- (5) BEDROCK SURFACE INTERPOLATED FROM ADJACENT DRILL HOLE INFORMATION.
- (6) PATTERNS USED FOR THE SLUDGE MATERIAL OF POOLS 2 AND 3 AS WELL AS THE EMBANKMENT MATERIAL OF DAM NO. 3 ARE FOR DELINEATION ONLY AND ARE NOT MEANT TO SUGGEST TEXTURE OR COMPOSITION.

W.A. WAHLER & ASSOCIATES

**COAL REFUSE DAM FAILURE
SAUNDERS, WEST VIRGINIA**

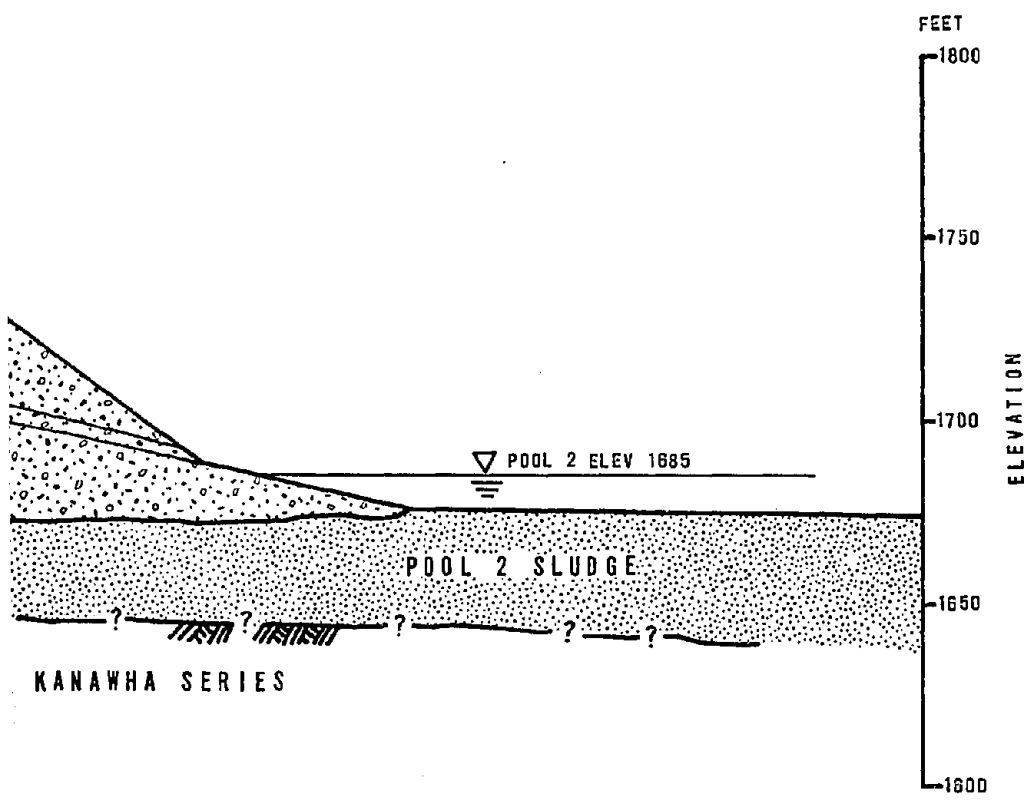

- (1) SECTION F-F' IS LOCATED RIGHT (LOOKING DOWNSTREAM) OF THE DAM MIDSECTION AS SHOWN IN FIGURE VII-11.
- (2) MOIST UNIT WEIGHTS OF THE EMBANKMENT MATERIALS WERE ASSUMED TO VARY FROM 96 pcf AT THE CREST OF THE DAM TO 106 pcf BELOW THE PHREATIC SURFACE.
- (3) INFINITELY HIGHER STRENGTHS WERE ASSUMED FOR THE BEDROCK MATERIAL AND ALL FAILURE SURFACES WERE ASSUMED TO BE CONFINED TO THE EMBANKMENT AND SLUDGE MATERIALS.
- (4) PORE PRESSURES ASSUMED FOR THE STABILITY ANALYSIS WERE DETERMINED FROM APPLICABLE FLOW NETS. (SEE FIGURES VII-18, VII-19 AND VII-20).
- (5) BEDROCK SURFACE INTERPOLATED FROM ADJACENT DRILL HOLE INFORMATION.
- (6) PATTERNS USED FOR THE SLUDGE MATERIAL OF POOLS 2 AND 3 AS WELL AS THE EMBANKMENT MATERIAL OF DAM NO. 3 ARE FOR DELINEATION ONLY AND ARE NOT MEANT TO SUGGEST TEXTURE OR COMPOSITION.

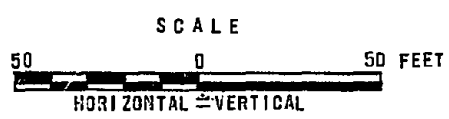

W.A. WAHLER & ASSOCIATES	COAL REFUSE DAM FAILURE SAUNDERS, WEST VIRGINIA	SECTION F-F' USED IN ANALYSIS COAL WASTE DAM NO. 3		
	<small>PALO ALTO • NEWPORT BEACH • CALIF.</small>	<small>PROJECT NO.</small> 0700	<small>DATE</small> NOVEMBER 1972	<small>FIGURE NO.</small> VII-13

constructed varied from a maximum of 55 feet in the center of the valley to 0 feet approximately 160 feet and 180 feet from the left and right crest-abutment contacts, respectively. Because of the sloping bedrock surface, however, the maximum thickness of foundation sludge increases beneath the downstream toe area to a maximum of 80-85 feet. The two sections chosen for detailed engineering analyses represent conditions of near maximum (50 feet) and average (25 feet) thickness of foundation sludge beneath the approximate center of the dam.

In the performance of our engineering analyses, all reasonably conceivable failure modes were considered. A number of these were rejected on the basis of being so improbable as to not warrant discussion herein. As a result of this elimination process, a total of four possible failure modes for Dams 2 and 3 appeared to warrant detailed consideration on the basis of all available evidence. These possible modes are discussed in detail below and then followed by Section F, which presents what we consider to be the most probable failure mode.

1. Failure Associated with Pipe Spillway

Although the published references generally agree that a 24-inch diameter pipe spillway was present in Dam No. 3 at the time of failure, there are some discrepancies. In the booklet "Disaster on Buffalo Creek," published by the Citizens' Commission to Investigate the Buffalo Creek Disaster, several people stated (p. 18-19) that there was no pipe spillway of any kind in Dam No. 3 until shortly before the disaster. Despite these statements, we have assumed that the 24-inch pipe was installed as described by the Commission Report.

Both the Commission Report and the Citizens' Commission booklet indicate that one or two 50-foot lengths of 24-inch diameter corrugated pipe were observed partially buried on the left upstream side of the dam

just prior to failure. It is not clear whether this pipe (or pipes) was placed intentionally as the first stage of a supplemental pipe spillway, or if continued dumping of refuse during the week prior to failure had resulted in the pipe (or pipes) becoming partially buried.

A Buffalo Mining Company official, in field conversations with representatives of W. A. Wahler and Associates, identified the two lengths of 24-inch uncorrugated steel pipe lying on the upper end of the refuse bank, near Dam No. 2 (Figure VI-4), as those intended to be installed as a supplementary spillway. However, the failure occurred before the installation was begun. These pipes apparently had been stockpiled at this location for some time before the failure. Although of similar type and length to the actual spillway pipes, it is inconceivable that these pipes could have been part of the spillway of Dam No. 3 and subsequently transported by the flood to their final position. Thus, their preflood and postflood positions must have been identical.

Of interest in the postfailure examinations of the site were the two lengths of 24-inch uncorrugated steel pipe projecting from the flood alluvium near the former location of the downstream toe of Dam No. 3 (Figure VII-14, Photo A). The locations of these pipes are plotted on Figure VI-20. The pipe located furthest downstream is referred to as the downstream pipe and the pipe furthest upstream (near Hole BS-17) is referred to as the upstream pipe. Each pipe was filled with coal refuse almost to its projecting end. Since the pipes were probably subjected to translation and rotation during the failure, the significance of the amount and orientation of the refuse blocking the pipes is difficult to determine.

Each pipe was pulled from the flood debris with a bulldozer winch for detailed examination. At the downstream pipe, a bulldozer trench was first excavated to a depth of about eight feet (Figure VII-14, Photo A) where excessive water was encountered. The material in the



PHOTO A. 24-INCH PIPES IN PLACE; BULLDOZER EXCAVATING TRENCH ADJACENT TO DOWNSTREAM PIPE (CIRCLED).



PHOTO B. DOWNSTREAM PIPE AFTER PULLING WITH WINCH.

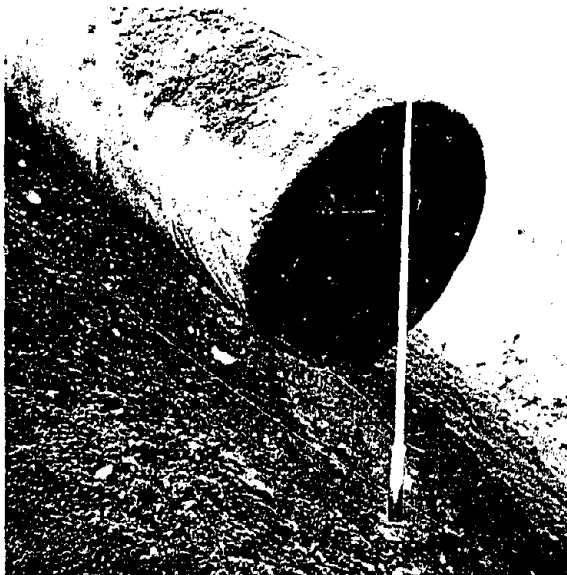

PHOTO C. DETAIL OF BURIED END OF UPSTREAM PIPE. NOTE ROUGH EDGES FROM TORCH CUTTING.



PHOTO D. UPSTREAM PIPE JUST AFTER PULLING IT TO THE EXPLORATORY BULLDOZER TRENCH ON THE LEFT ABUTMENT OF DAM NO. 3.

trench walls was coal waste deposited by the flood, indicating that the pipe was carried in the bed load of the flood water after the failure. The downstream pipe was examined after extraction and found to be 44.5 feet long with both ends apparently torch-cut, unbroken by pulling, and unwelded. In the opinion of the bulldozer operator, the pipe pulled "very easily," as though unconnected to anything at its buried end.

The upstream pipe was pulled from soft, saturated foundation material by a bulldozer located in a partially completed exploration trench on the left abutment of Dam No. 3 (Figure VII-14, Photo D) and was found to be 45.1 feet long. The buried end (Figure VII-14, Photo C) was slightly flattened, torch-cut, did not appear to be broken by pulling action, and showed no sign of welding. In the opinions of the bulldozer operator and an observer stationed near the pipe, the pipe pulled very easily and there was no indication its buried end was attached to anything. The location of this pipe in relation to postfailure positions of parts of Dam No. 3 is not well defined; it appears to be largely within the zone of possible bottom transport by the flood waters, rather than embedded in a translated section of the dam embankment.

The reported pipe spillway had an orientation trending about $N75^{\circ}W$ (Figure V-16). The recovered downstream and upstream pipes trended about $N10^{\circ}W$ and $N20^{\circ}E$, respectively (Figure VI-20). Thus, the rotations (in a horizontal plane) required to put the pipes in their present positions, assuming they were part of the spillway pipe, are 95° for the upstream pipe and 65° for the downstream pipe. The field relations and these minimum rotations suggest that both pipes arrived at their present locations by turbulent transport as part of the bed load of the flood. If these pipes are indeed representative of the spillway of Dam No. 3, then the rest of the spillway pipe must lie beneath the flood debris. The total length of spillway pipe in

Dam No. 3 appears to have been about 290 feet. The pipes that were pulled from the flood debris account for 90 feet, leaving 200 feet missing. If this 200 feet of pipe existed as a single welded unit, burial in flood debris without partial exposure seems unlikely. Therefore, the spillway could possibly have been constructed with several 40- to 50-foot long sections of 24-inch pipe laid loosely end-to-end and unconnected in a trench across the crest of Dam No. 3 and then buried.

If this assumption is correct, water could have readily leaked through the unwelded joints of the spillway pipe and produced local saturation in Dam No. 3. However, according to testimony, the pipe did not carry water until about 1-3/4 days before the failure and probably carried water only on rare occasions, if ever, during previous storms. The amount of water that the open joints of the pipe could introduce into the embankment would depend upon the width of the openings, the amount of water flowing, and the length of time the flow occurred. The effect of such a spillway flowing full, or partially full, would be to raise the phreatic surface locally and decrease the stability in the downstream area of the embankment. Additionally, the pipe would have discharged onto the downstream face of the dam causing erosion and possibly local slumping. It is difficult to assess what contribution, if any, these actions may have had on the ultimate collapse. It is quite obvious, as discussed later in this section, that the single spillway pipe was not the principal cause of the ultimate dam failure.

2. Overtopping of Dams 1, 2, and 3

Overtopping is defined as the progressive erosion of an embankment beginning with water from the reservoir flowing over the top of the embankment at its lowest point. As the erosive action continues, the initial channel is widened by undercutting of the sides, the adjacent

banks shear and fall into the breach, thereby increasing the quantity of flow and the erosive forces. This action continues until the reservoir impounded by the embankment has been drained or until the level of the upstream and downstream water surfaces are nearly equal and the flow velocity is reduced so that no further erosion occurs.

The fact that all three dams were impounding water at the time of failure required that the possibility of overtopping for each dam be investigated. The probability that Dam No. 1 was overtopped by normal inflow of water into Pool 1 is very low. As indicated previously, two 24-inch diameter spillway pipes were provided which discharged near the right abutment into a ditch along the right side of the No. 5 Mine Road downstream of the dam. The capacity of these pipes, when flowing full was calculated to be about 70 cubic feet per second, or 5.8 acre-feet per hour. The latter figure indicates that the two discharge pipes could safely accommodate a rise of the water surface elevation of Pool 1 (capacity 12.6 acres) at the rate of about 5-6 inches per hour. This inflow rate appears highly unlikely, even under heavy rainfall conditions, because the flow into Pool 1 was only the result of seepage through Dam No. 2 and any runoff from the small drainage area immediately bordering the pool. Finally, the testimony contained in the Senate Subcommittee Hearings indicates that a slide in the right abutment area, which occurred in the late evening of February 25 or the early morning of February 26, actually blocked the main drainage ditch along the right side of the No. 5 Mine Road and diverted this water into Pool 1. The water rose rather rapidly in the pool before it was discovered that one of the drainage pipes was blocked. After the pipe was subsequently cleaned out, the testimony indicates that the level of Pool 1 diminished and that the pool was at its normal level at least four feet below the crest of the dam within one to two hours before failure.

Dam No. 2 was provided with a 30-inch diameter spillway pipe with its invert at Elevation 1,685 or about 5 feet below the crest. The pipe was located near the right abutment of the dam and discharged into the same drainage ditch as described above for Dam No. 1. The pipe capacity, when flowing full, was calculated to be about 50 cubic feet per second, or 4.1 acre-feet per hour. Inflow into Pool 2 was limited to a combination of Dam No. 3 seepage, overflow through Dam No. 3 spillway, and runoff from the drainage area along either side of the pool. Under previous winter flow conditions, the seepage through Dam No. 3, could have been as high as 1,700,000 gallons per day, or 0.22 acre-feet per hour. Even under full reservoir level conditions, the seepage probably did not exceed 0.29 acre-feet per hour. These values are well below the Dam No. 2 spillway pipe capacity and the probability of Dam No. 2 overtopping as a direct result of storm water inflow is rather low.

Dam No. 3 had a 24-inch diameter spillway pipe with an invert at about Elevation 1,745 or seven to eight feet below the low point of the embankment crest near the right abutment. Unlike the discharge pipes for Dams 1 and 2, the pipe for Dam No. 3 was oriented diagonally across the dam, with the intake near the right abutment and the discharge near the right center portion of the downstream face. The maximum pipe capacity when flowing full was calculated to be about 35 cubic feet per second, or 2.9 acre-feet per hour.

The day to day inflow of storm runoff into Pool 3 during the months of January and February 1972 was irregular. For the purposes of recreating the conditions at the time of failure, it was not considered necessary to derive the exact rate of reservoir rise from the normal pool Elevation 1,735 to the flood stage Elevation 1,753. It is important to point out, however, that the 18 feet of rise in reservoir level was not due entirely to the storm of February 25-26. The majority of the reservoir rise was due to the natural accumulation of water during

the rainy months when the rate of inflow to the reservoir exceeded the seepage rate through Dam No. 3.

In order to evaluate testimony regarding the rate of rise of reservoir level, it is necessary to consider the approximate 12-hour period preceding failure. According to Mr. D. Osbourne (U.S. Congress 1972b, p. 1282) an unofficial rain gauge was set up near the Buffalo Mining Company offices near Lorado the evening of February 25, and from 2000 hours on February 25 through 0700 hours on February 26, a total rainfall of 1.75 inches was recorded. Considering that the drainage basin detention time was about 2 to 3 hours and the near-saturated conditions resulting from two consecutive months of above average rainfall, it is reasonable to assume that 75 to 80 percent of this rainfall actually reached the reservoir before failure. This would amount to 71 to 76 acre-feet of inflow. As shown on Figure VII-10, the water level was at about Elevation 1,750 at 2000 hours on February 25. The available capacity within Pool 3 between Elevations 1,750 and 1,753, as shown on the area-capacity curve on Figure VII-15, was approximately 35 acre-feet. Assuming that the spillway pipe was functioning at full capacity, the total flow through the pipe was calculated to be about 35 acre-feet during the 12-hour period preceding failure. The total seepage through the dam was calculated to be about 4 acre-feet during this same period. A water balance relationship indicates that the sum of inflow, minus seepage, minus pipe discharge, must be equal to or less than the remaining reservoir capacity in order to preclude overtopping. If the inflow during the period was 71 acre-feet, Pool 3 reservoir would still have had 3 acre-feet of storage capacity at the time of failure. On the other hand, if the inflow amounted to 76 acre-feet, then the reservoir capacity would have been exceeded by 2 acre-feet and overtopping of the dam would have begun. It must be pointed out that the uncertainty of both the rainfall data for the Middle Fork area and the amount of reservoir inflow and outflow up to the time of failure prevents any definitive conclusions regarding overtopping on the basis of reservoir hydrology and hydraulics alone. However, using the values

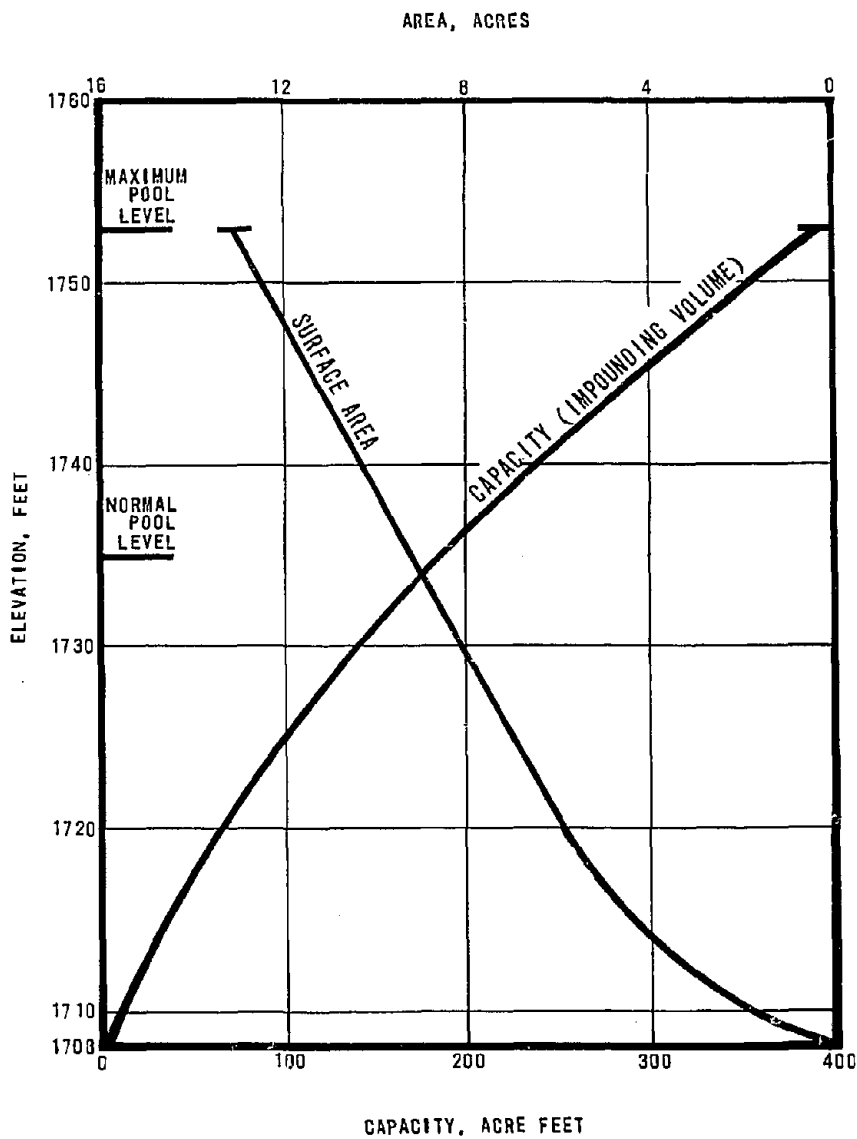

NOTE: (1) THE CAPACITY OF THE RESERVOIR IS SHOWN STARTING AT ELEVATION 1708 WHICH COINCIDES WITH THE POOL 3 SLUDGE LEVEL AT THE UPSTREAM TOE OF DAM NO. 3.

170

W. A. WAHLER
& ASSOCIATES

COAL REFUSE DAM FAILURE
SAUNDERS, WEST VIRGINIA

AREA - CAPACITY CURVE
POOL 3

PALO ALTO • NEWPORT BEACH • CALIF.

PROJECT NO.
0700.

DATE
NOVEMBER 1972

FIGURE NO.
VII-15

referenced above, and the analyses of the other possible modes of failure discussed below, we conclude that failure of Dam No. 3 did not occur by overtopping. It is highly probable that, because of insufficient spillway capacity, an overtopping failure would have occurred had the dam not failed by other means. Failure by overtopping would have been in a less rapid manner than that of the actual failure.

3. Foundation Piping

The presence of boils and related piping within the foundation sludge of Pool 2 beneath the downstream toe of Dam No. 3 was noticed soon after its completion and apparently persisted in an intermittent fashion up to the time of the failure. These boils were described as the emergence of black water in the relatively clean pool of water downstream of the toe of Dam No. 3.

The significance of these boils was obviously not understood by any of the observers; the presence of boils is usually associated with the threat of progressive piping. Seepage forces which develop when water flows through a soil are resisted by the effective grain-to-grain contact stress. If this stress is insufficient to resist the seepage forces, then an unbalance of forces results in the direction of flow. Usually this unbalance of forces is greatest at the exit point of the seepage and results in physical movement of soil particles. This process of gradual internal erosion is known as piping.

As discussed earlier in this chapter, the ratio of the horizontal to vertical permeability for the embankment is low and for analytical purposes assumed to be unity ($k_h / k_v = 1$). This same ratio for the sludge has a much greater range due to the stratification induced by the hydraulic deposition of these materials. This factor of hydraulic anisotropy so greatly influenced the pore water pressure and seepage forces in the sludge material that it was necessary to perform analyses with

horizontal to vertical permeability ratios of 25:1 and 100:1. For the specific sections analyzed, the greater the ratio, the greater the pore pressures in the downstream area of the foundation.

The embankment and foundation conditions required a more accurate determination of seepage than is normally necessary in the evaluation of zoned dams having outer shells hundreds of times more pervious than the central core zone. Studies of seepage through earth dams can be performed by means of a flow net which is a system of two sets of mutually orthogonal intersecting curves. One set of curves represents the flow lines or stream lines and the other set represents the equipotential lines. A flow net is drawn using a trial and error method until the final solution accurately depicts the potential energy loss of the water as it flows through the embankment-foundation limits which confine or form the boundaries of the flow. The parameters which govern the development of the flow net consist of the upstream and downstream free water surface elevations, the relative values of the coefficients of permeability (both in a horizontal and vertical direction) of the embankment and foundation material, and the configuration of the embankment and foundation. Once completed, the flow net permits a determination of the total quantity of seepage through the embankment and foundation, the interstitial pore water pressure, and the pressure gradient (total head loss per unit length of flow path) at any point within the defined boundary of flow.

Appropriate flow nets for varying thicknesses of foundation sludge material appear on Figures VII-16, VII-17, VII-18 and VII-19. They represent differing flow patterns resulting from normal and maximum Pool 3 levels and variations in the hydraulic anisotropy of the sludge material. It may be noted that for both Pool 3 levels, the flow nets, for a given horizontal to vertical permeability ratio, are very nearly the same. This is primarily due to the configuration of the embankment and the use of the same number of equipotential lines in each case.

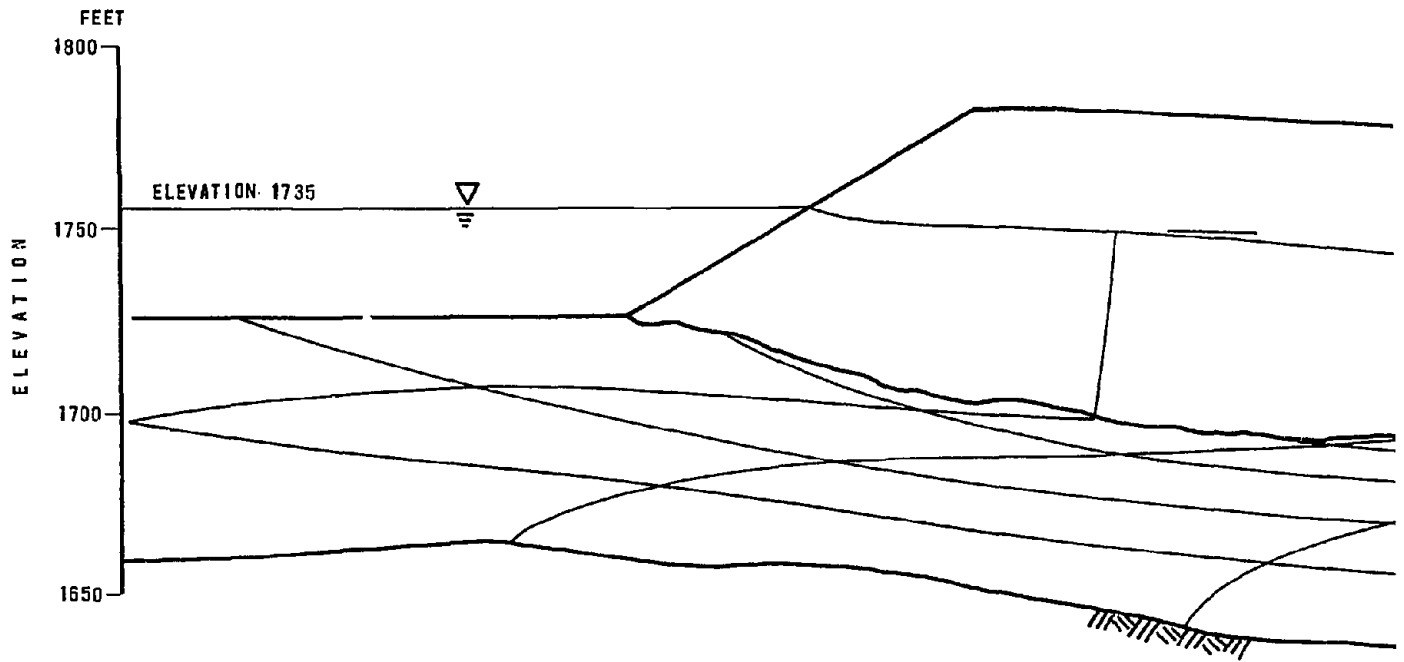

SECTION E-E' FLOW NET: FOUR

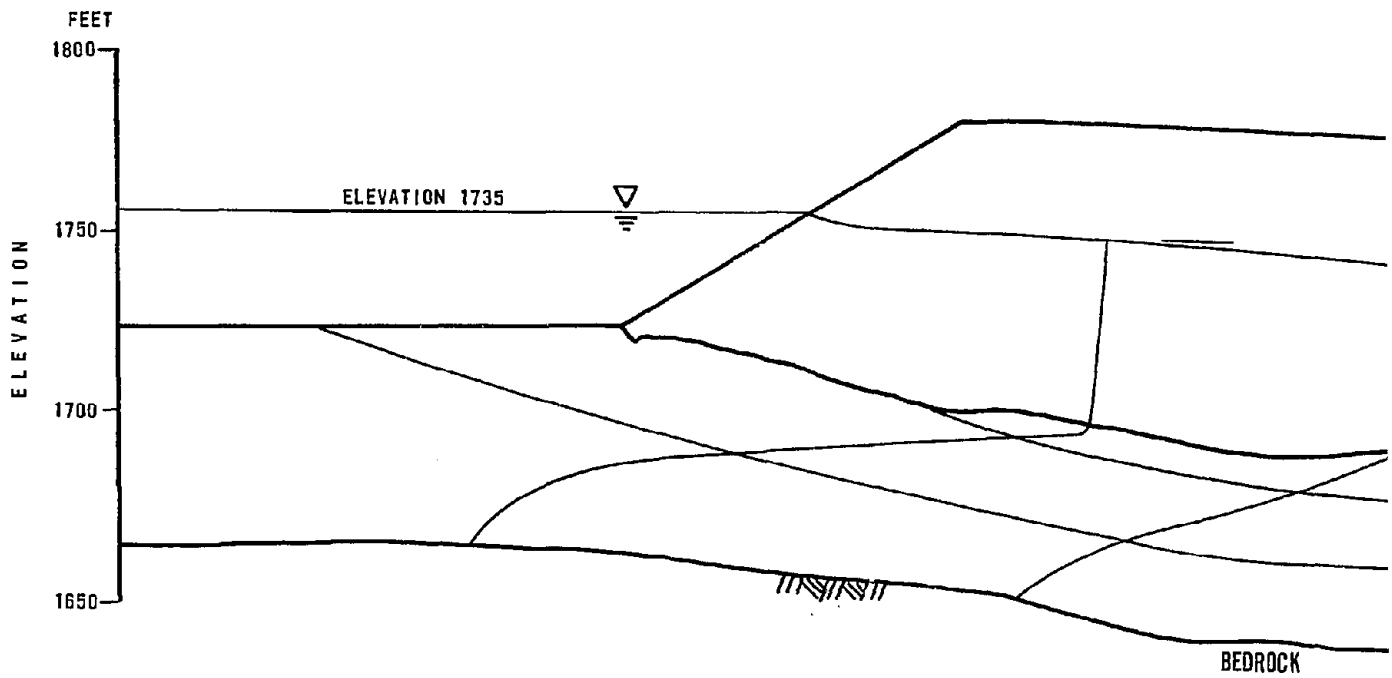

SECTION E-E' FLOW NET: FOUR

- NOTES: (1) EQUIVALENT EMBANKMENT PERMEABILITY = $k_E = k_h = k_v$
EQUIVALENT FOUNDATION (SLUDGE) PERMEABILITY = $k_F = \sqrt{k_v \times k_h}$
- (2) FOR MORE DETAILED INFORMATION ON PERMEABILITY DATA SEE CHAPTER VII, SECTIONS B AND E, AND APPENDIX B.
- (3) THESE SECTIONS ARE DRAWN TO TRUE SCALE. THE ORIGINAL FLOW NETS WERE DRAWN ON TRANSFORMED SECTIONS WHICH WERE CONSTRUCTED BY EXPANDING THE DEPTH OF THE FOUNDATION BY A FACTOR OF $\sqrt{k_h/k_v}$
- (4) FIGURE VII-20 DEMONSTRATES THE USE OF FLOW NETS IN PORE PRESSURE DETERMINATION FOR STABILITY ANALYSES.

$$i_{\text{exit}} = \frac{\Delta h}{\Delta l} = \frac{3.55'}{12.0'} = 0.30$$

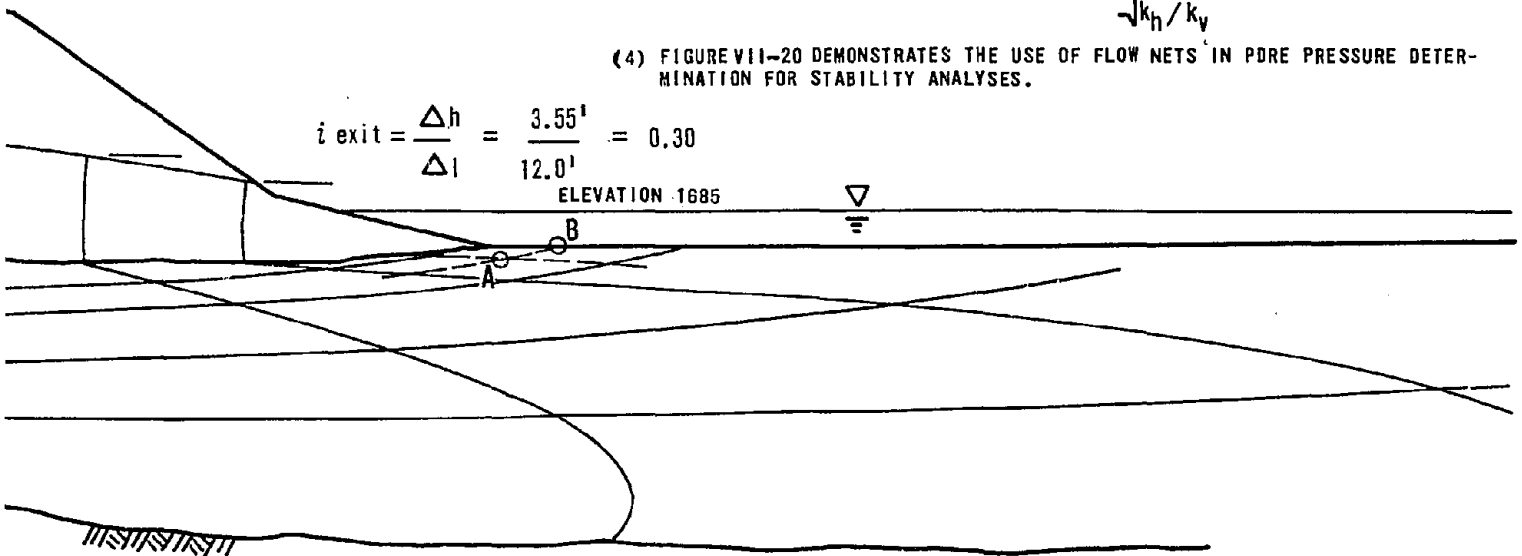

Ratio = 100; NORMAL RESERVOIR LEVEL

Δh = HEAD LOSS BETWEEN POINTS A AND B.
 Δl = LENGTH OF FLOW PATH BETWEEN POINTS A AND B.

$$i_{\text{exit}} = \frac{\Delta h}{\Delta l} = \frac{3.55'}{16.0'} = 0.22$$

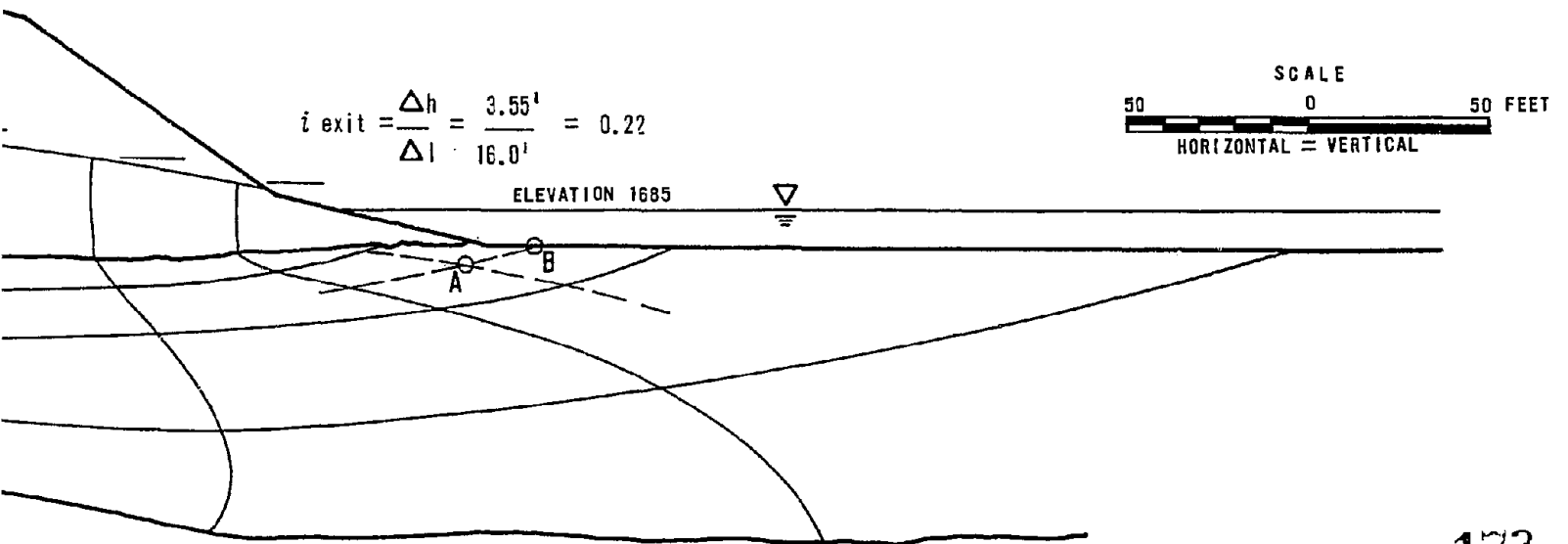

Ratio = 25; NORMAL RESERVOIR LEVEL

W. A. WAHLER & ASSOCIATES	COAL REFUSE DAM FAILURE SAUNDERS, WEST VIRGINIA PALO ALTO • NEWPORT BEACH • CALIF.	SECTION E-E' FLOW NETS - NORMAL POI COAL WASTE DAM NO. 3		
		PROJECT NO. 0700	DATE NOVEMBER 1972	FIGURE VII-11

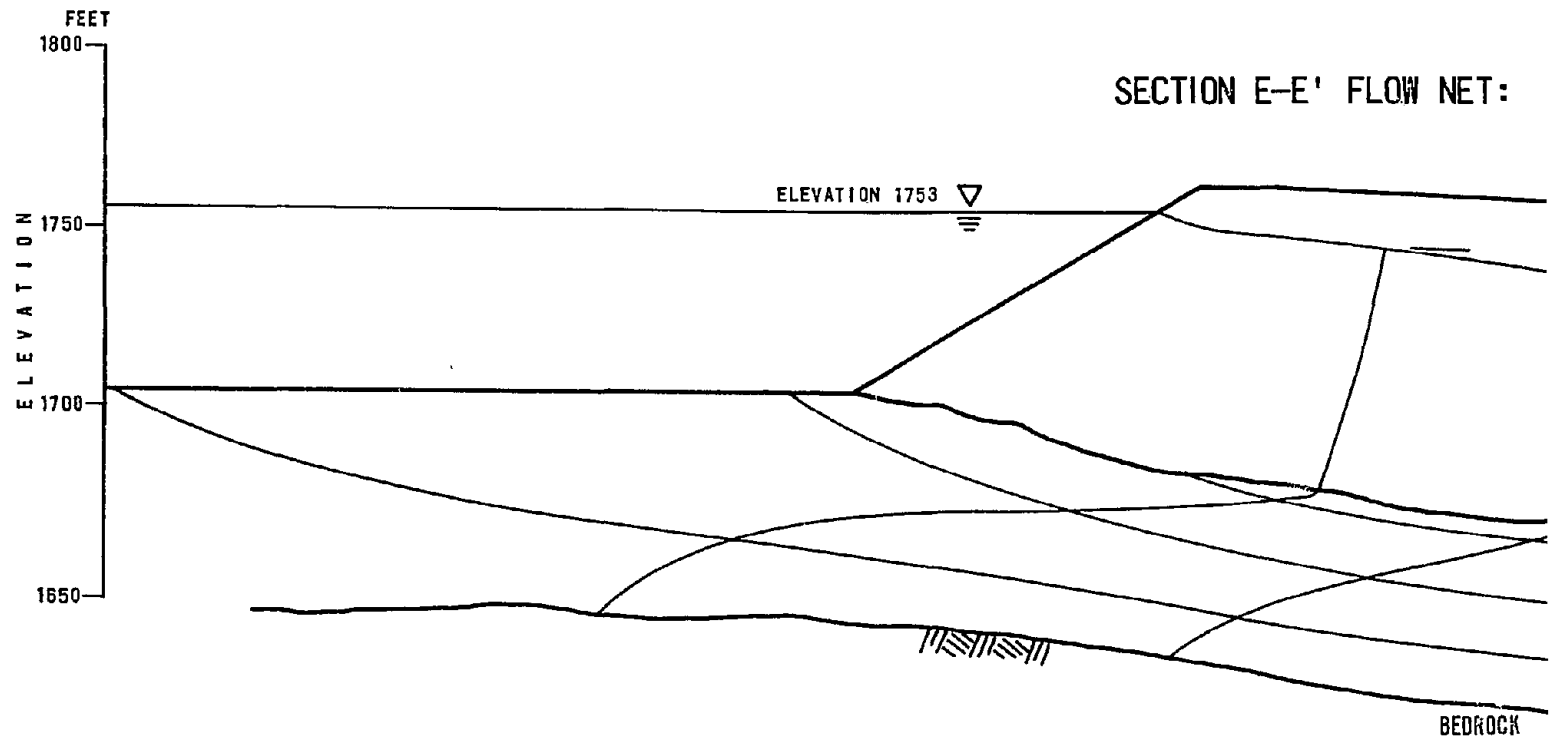
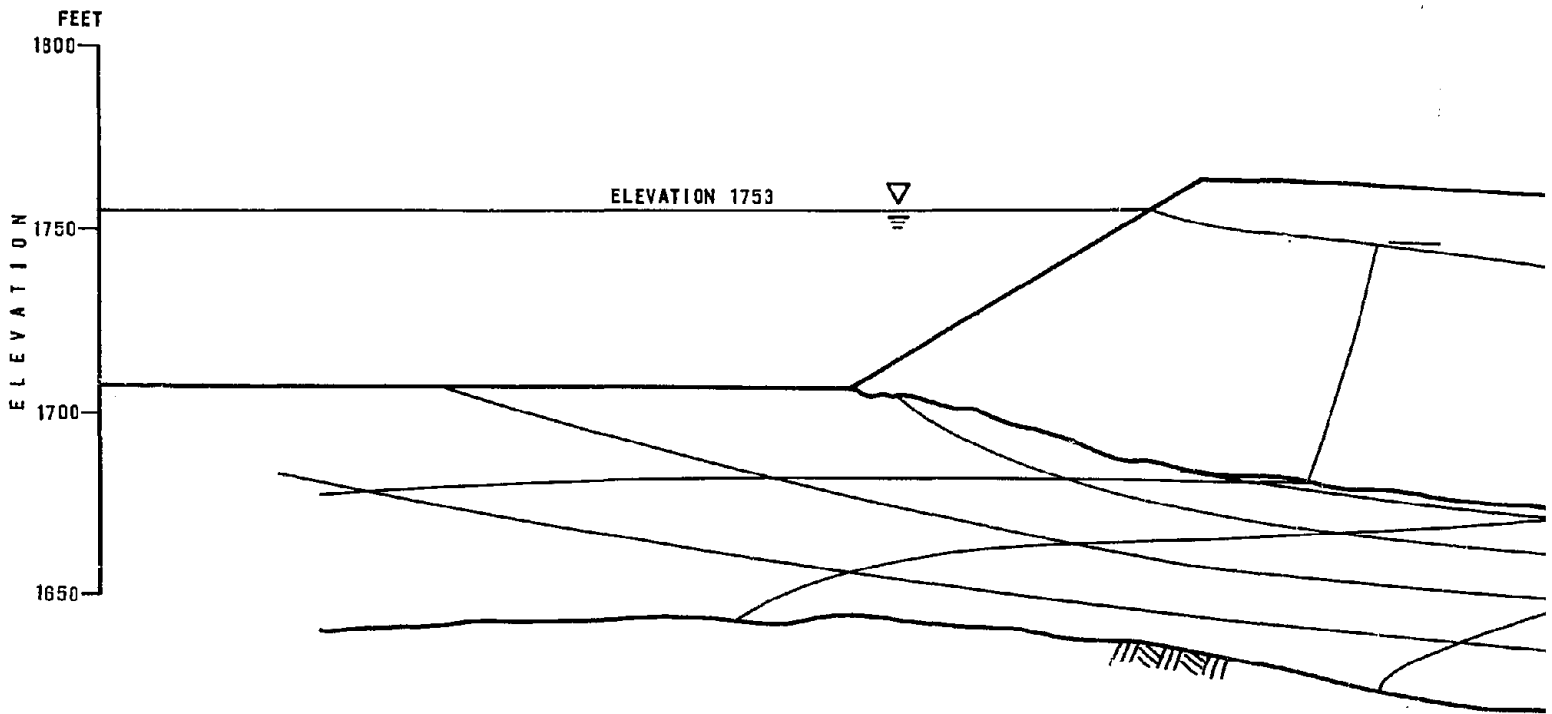

SECTION E-E' FLOW NET:

- NOTES: (1) EQUIVALENT EMBANKMENT PERMEABILITY = $k_E = k_h = k_v$
 EQUIVALENT FOUNDATION (SLUDGE) PERMEABILITY = $k_F = \sqrt{k_v \times k_h}$
- (2) FOR MORE DETAILED INFORMATION ON PERMEABILITY DATA SEE CHAPTER VII, SECTIONS B AND E, AND APPENDIX B.
- (3) THESE SECTIONS ARE DRAWN TO TRUE SCALE. THE ORIGINAL FLOW NETS WERE DRAWN ON TRANSFORMED SECTIONS WHICH WERE CONSTRUCTED BY EXPANDING THE DEPTH OF THE FOUNDATION BY A FACTOR OF $\sqrt{k_h/k_v}$
- (4) FIGURE VII-20 DEMONSTRATES THE USE OF FLOW NETS IN PORE PRESSURE DETERMINATION FOR STABILITY ANALYSES.

$$i_{\text{exit}} = \frac{\Delta h}{\Delta l} = \frac{4.9'}{13.0'} = 0.38$$

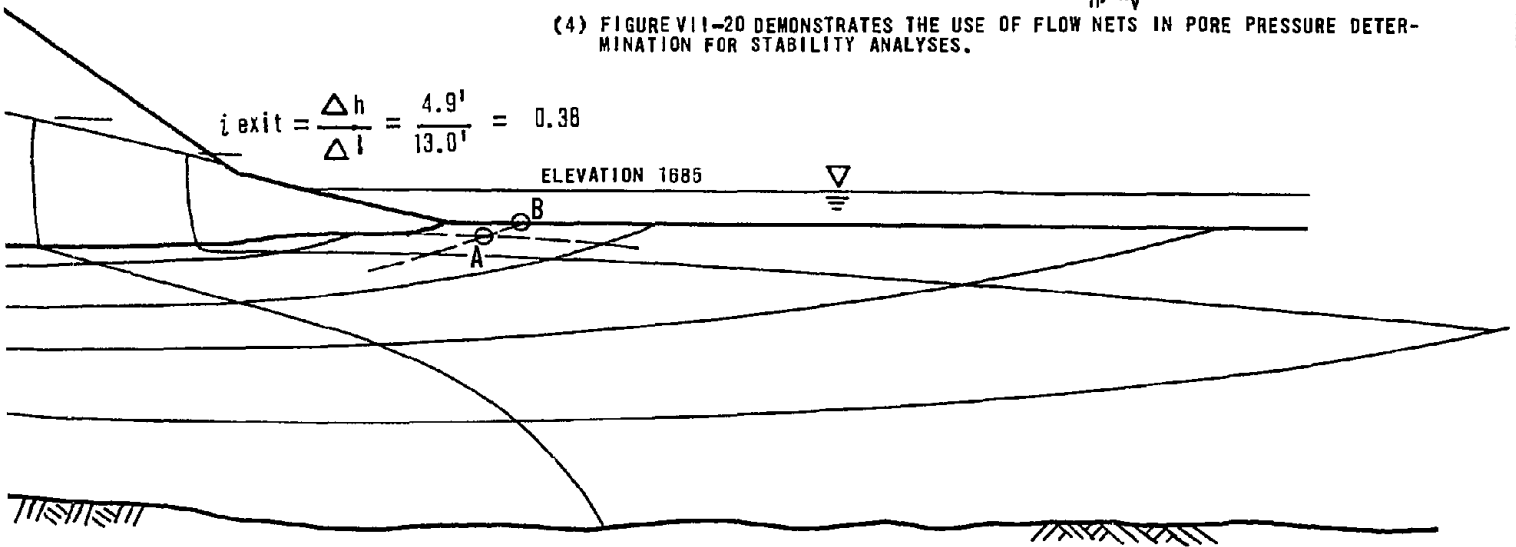

= 100; HIGH RESERVOIR LEVEL

Δh = HEAD LOSS BETWEEN POINTS A AND B.
 Δl = LENGTH OF FLOW PATH BETWEEN POINTS A AND B.

$$i_{\text{exit}} = \frac{\Delta h}{\Delta l} = \frac{4.9'}{18.0'} = 0.27$$

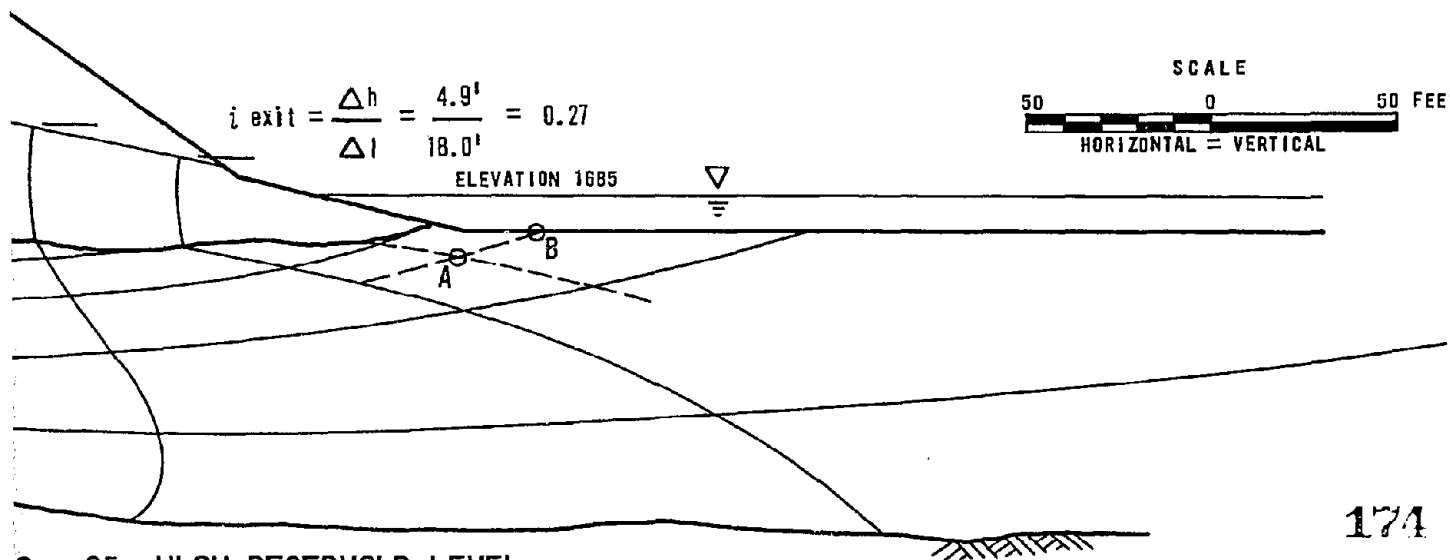

174

W. A. WAHLER
& ASSOCIATES

COAL REFUSE DAM FAILURE
SAUNDERS, WEST VIRGINIA

PALO ALTO • NEWPORT BEACH • CALIF.

SECTION E-E' FLOW NETS - MAXIMUM POOL
COAL WASTE DAM NO. 3

PROJECT NO.

DATE

FIGURE NO.

0700

NOVEMBER 1972

VII-17

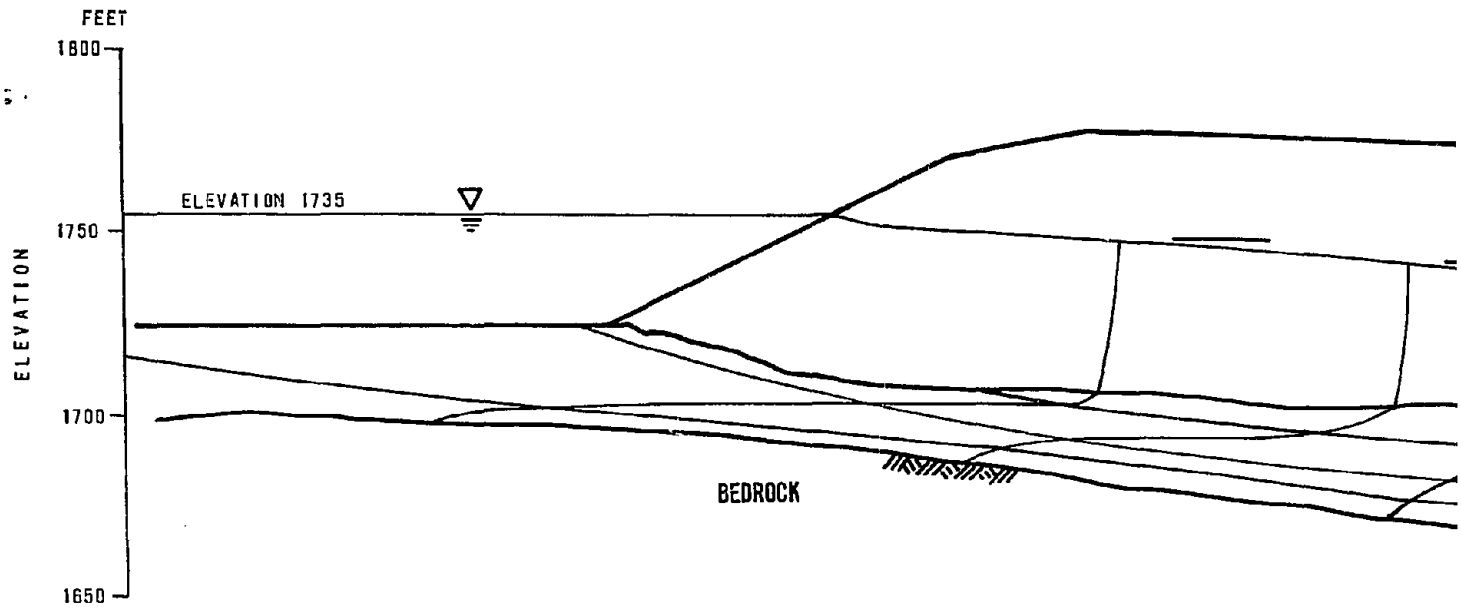

SECTION F-F' FLOW NET: FOUNDATION

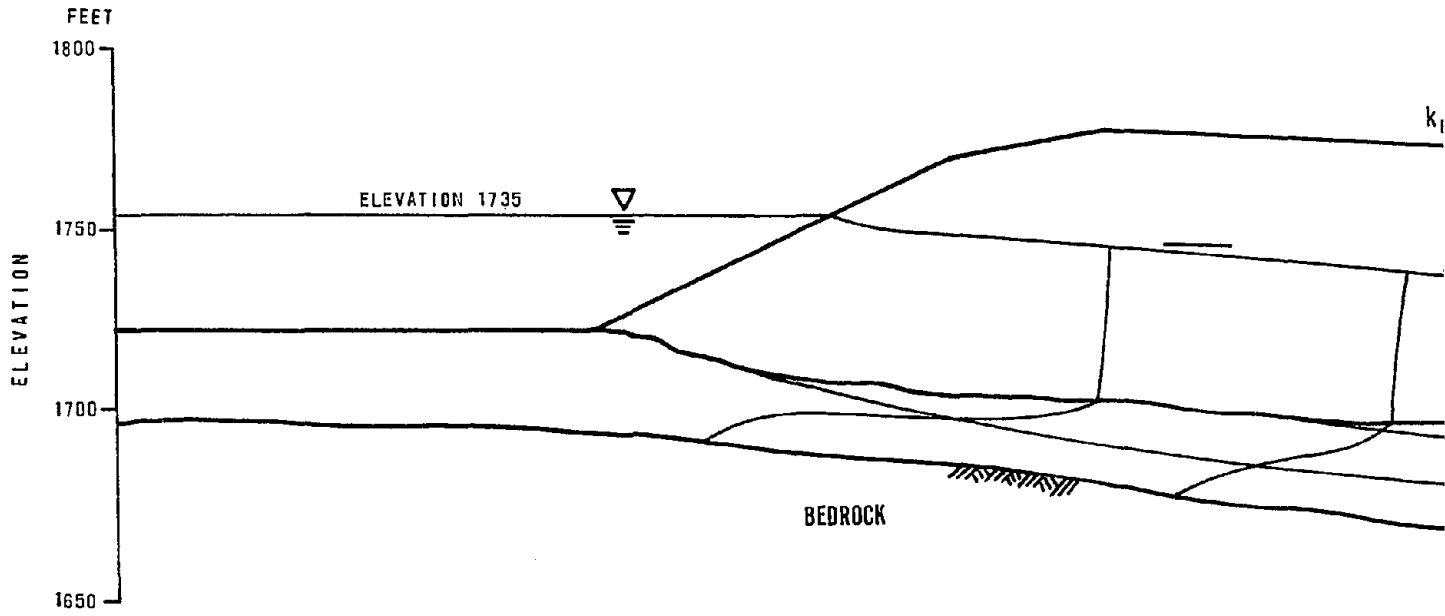

SECTION F-F' FLOW NET: FOUNDATION

- NOTES: (1) EQUIVALENT EMBANKMENT PERMEABILITY = $k_E =$
EQUIVALENT FOUNDATION (SLUDGE) PERMEABILITY
- (2) FOR MORE DETAILED INFORMATION ON PERMEABILITY
SECTIONS B AND E, AND APPENDIX B.
- (3) THESE SECTIONS ARE DRAWN TO TRUE SCALE. THEY
WERE DRAWN ON TRANSFORMED SECTIONS WHICH WERE CORRECTED
DEPTH OF THE FOUNDATION BY A FACTOR OF
- (4) FIGURE VII-20 DEMONSTRATES THE USE OF FLOW
DISTRIBUTION FOR STABILITY ANALYSES.

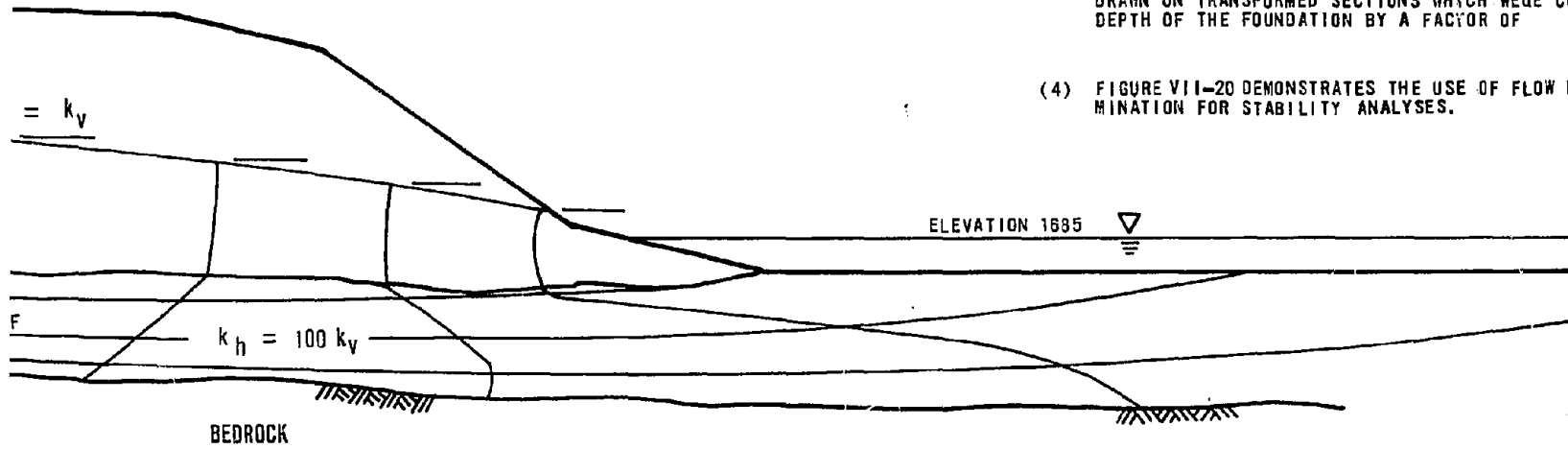

PERMEABILITY RATIO = 100; NORMAL RESERVOIR LEVEL

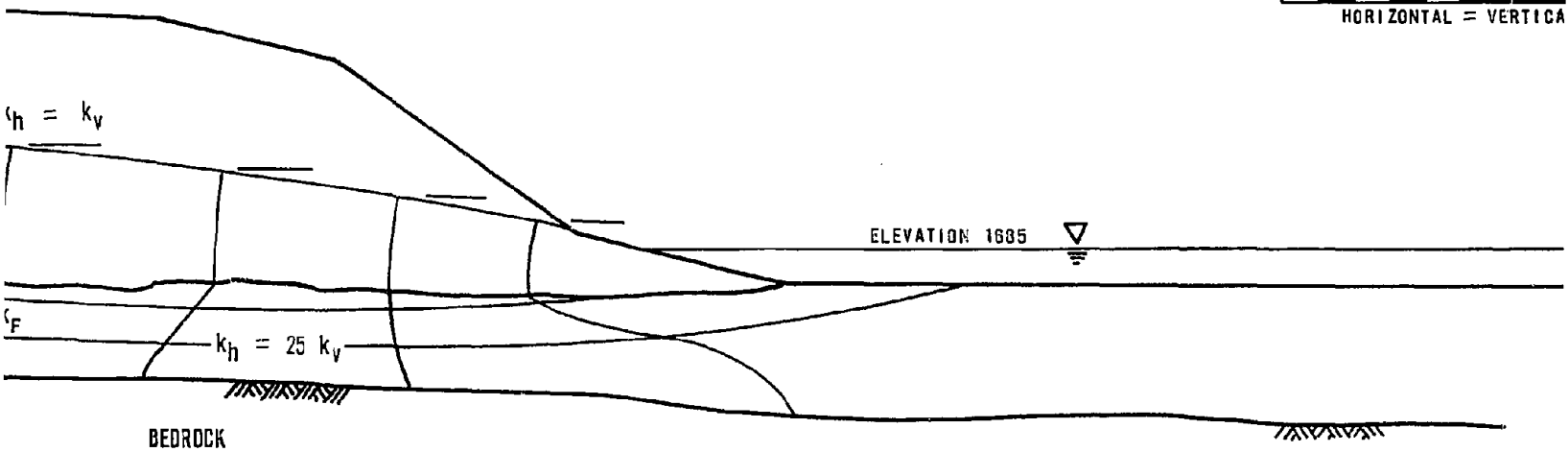

PERMEABILITY RATIO = 25; NORMAL RESERVOIR LEVEL

W.A. WAHLER & ASSOCIATES	COAL REFUSE DAM FAILURE SAUNDERS, WEST VIRGINIA	SECTION F-F FLOW	
		COAL WA	
PALO ALTO • NEWPORT BEACH • CALIF.		PROJECT NO.	
		0700	NOV

NOTES: (1) EQUIVALENT EMBANKMENT PERMEABILITY = $k_E = k_H = k_V$

EQUIVALENT FOUNDATION (SLUDGE) PERMEABILITY = $k_F = \sqrt{k_V \times k_H}$

(2) FOR MORE DETAILED INFORMATION ON PERMEABILITY DATA SEE CHAPTER VII, SECTIONS B AND E, AND APPENDIX B.

(3) THESE SECTIONS ARE DRAWN TO TRUE SCALE. THE ORIGINAL FLOW NETS WERE DRAWN ON TRANSFORMED SECTIONS WHICH WERE CONSTRUCTED BY EXPANDING THE DEPTH OF THE FOUNDATION BY A FACTOR OF

$$\sqrt{k_H/k_V}$$

(4) FIGURE VII-20 DEMONSTRATES THE USE OF FLOW NETS IN PORE PRESSURE DETERMINATION FOR STABILITY ANALYSES.

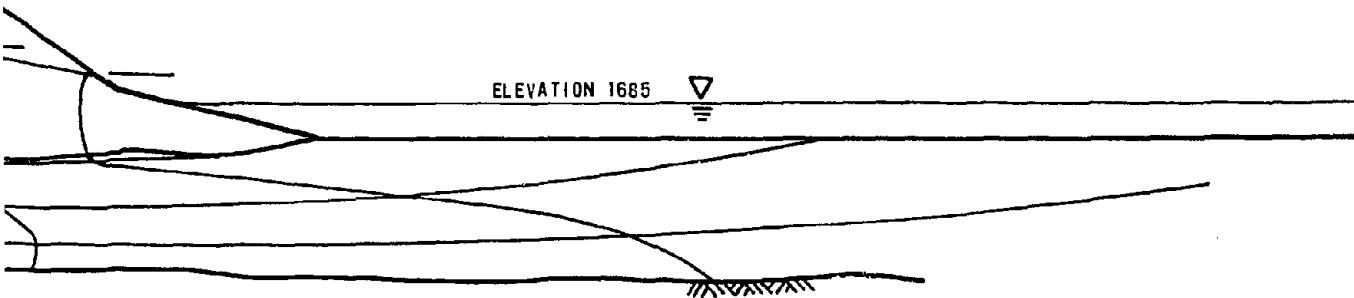

NORMAL RESERVOIR LEVEL

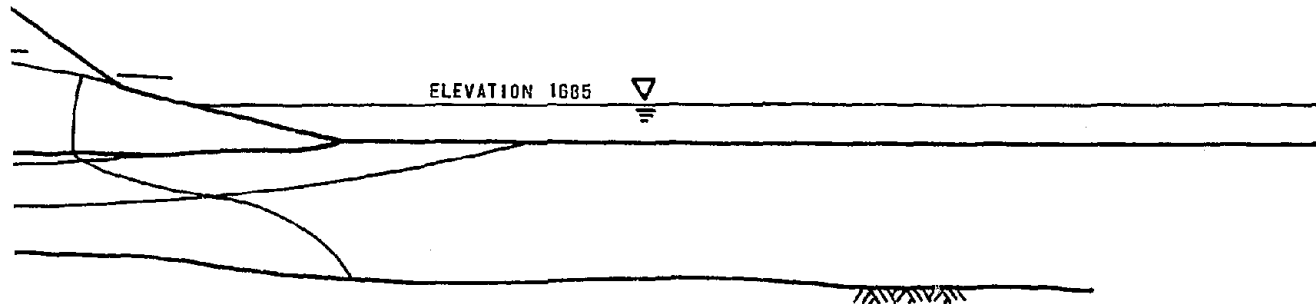

NORMAL RESERVOIR LEVEL

175

W.A. WAHLER & ASSOCIATES	COAL REFUSE DAM FAILURE SAUNDERS, WEST VIRGINIA	SECTION F-F FLOW NETS-NORMAL POOL COAL WASTE DAM NO. 3		
		PROJECT NO. 0700	DATE NOVEMBER 1972	FIGURE NO. VII-18
PALO ALTO • NEWPORT BEACH • CALIF.				

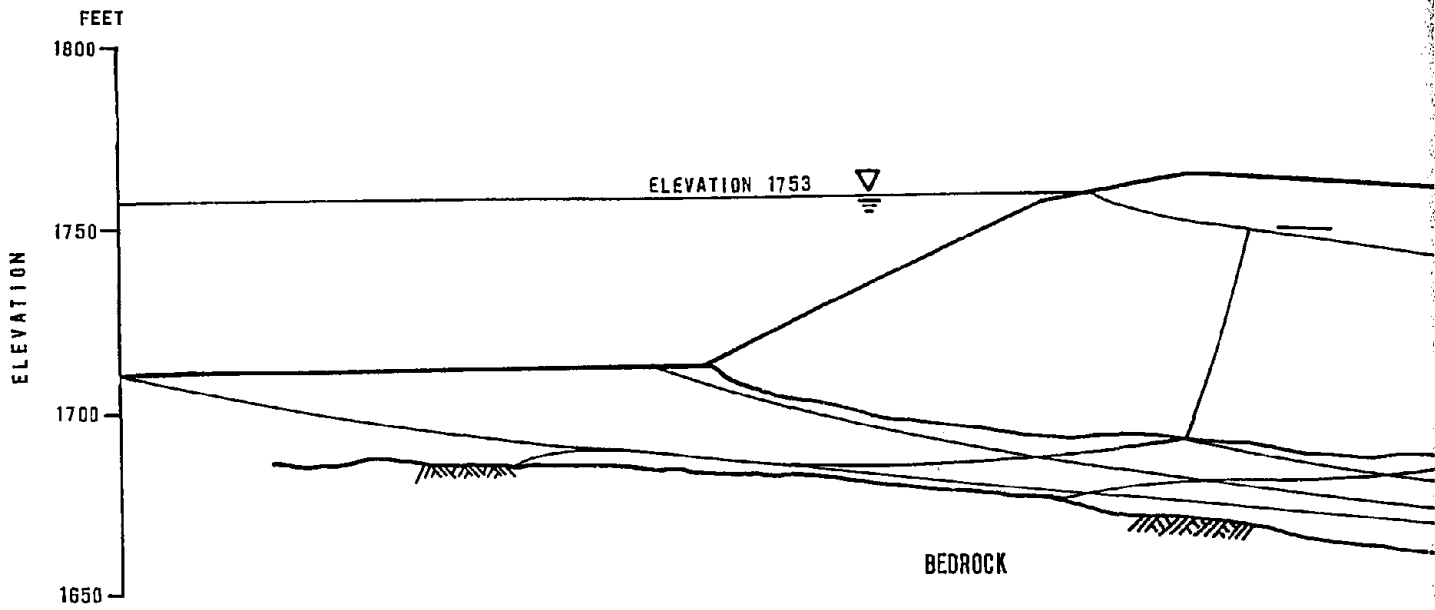

SECTION F-F' FLOW NET: F

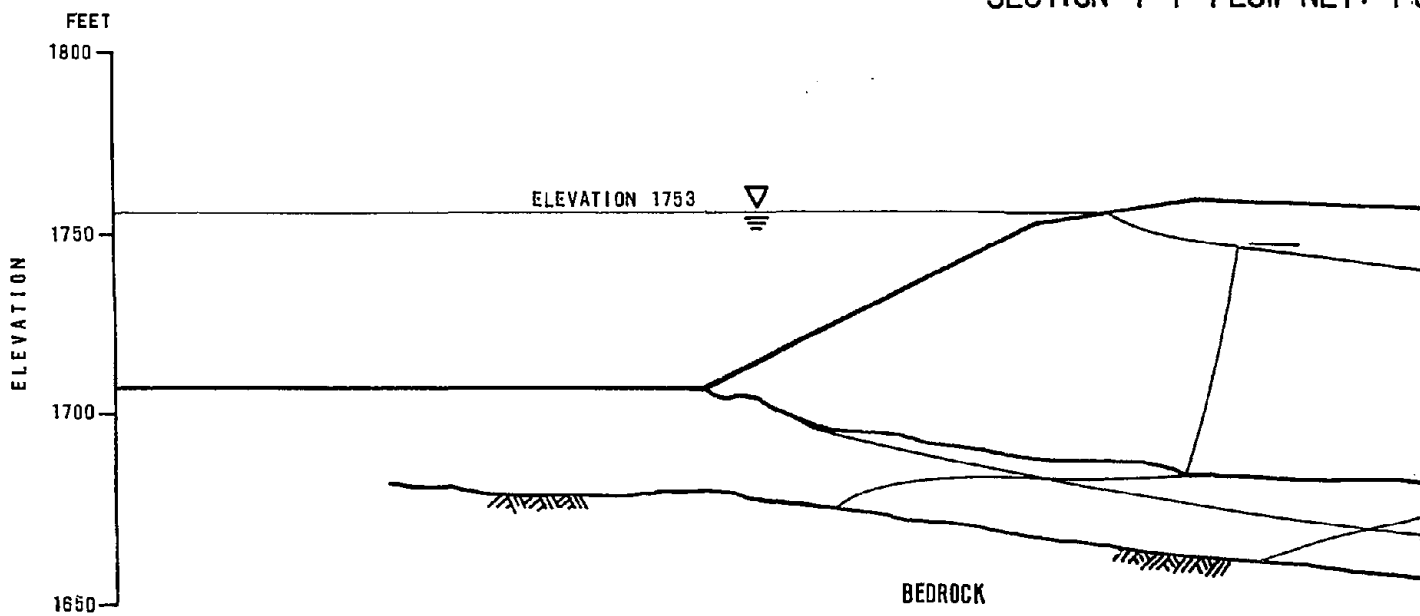

SECTION F-F' FLOW NET: F

- NOTES: (1) EQUIVALENT EMBANKMENT PERMEABILITY = k_E
 EQUIVALENT FOUNDATION (SLUDGE) PERMEABILITY = k_F
- (2) FOR MORE DETAILED INFORMATION ON PERMEABILITY RATIOS, SEE
 SECTIONS B AND E, AND APPENDIX B.
- (3) THESE SECTIONS ARE DRAWN TO TRUE SCALE, EXCEPT FOR THE
 FOUNDATION WHICH WAS DRAWN ON TRANSFORMED SECTIONS WHICH WERE
 DEPTH OF THE FOUNDATION BY A FACTOR OF 10.
- (4) FIGURE VII-20 DEMONSTRATES THE USE OF PERMEABILITY
 TRANSFORMATION FOR STABILITY ANALYSIS.

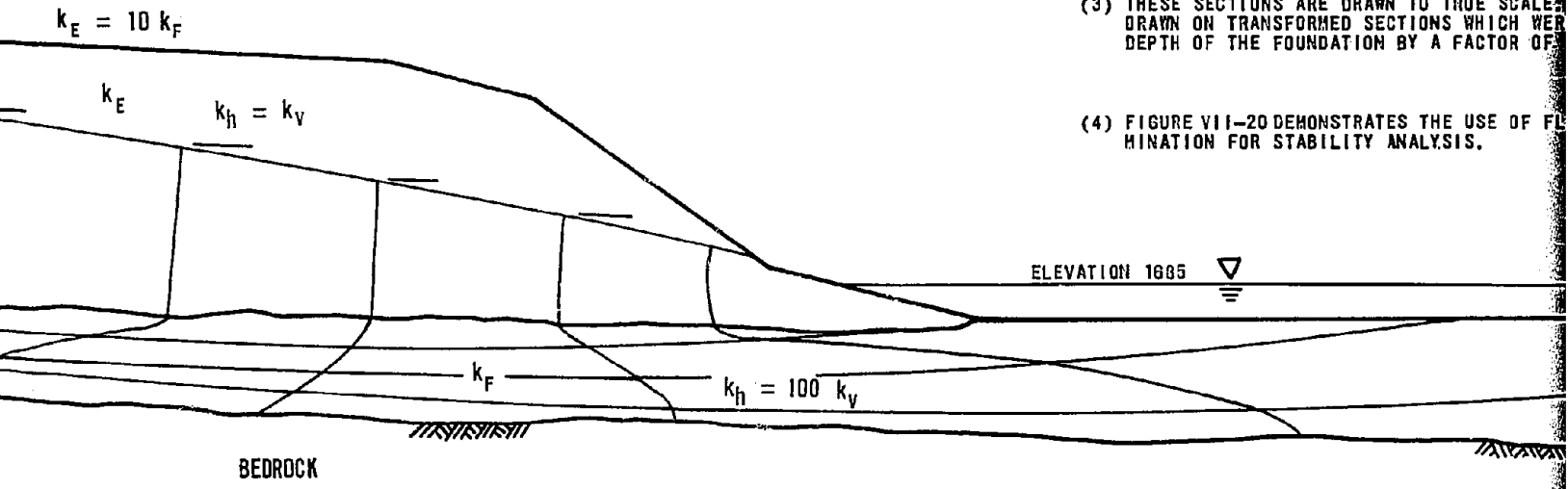

ANISOTROPIC PERMEABILITY RATIO = 100; HIGH RESERVOIR LEVEL

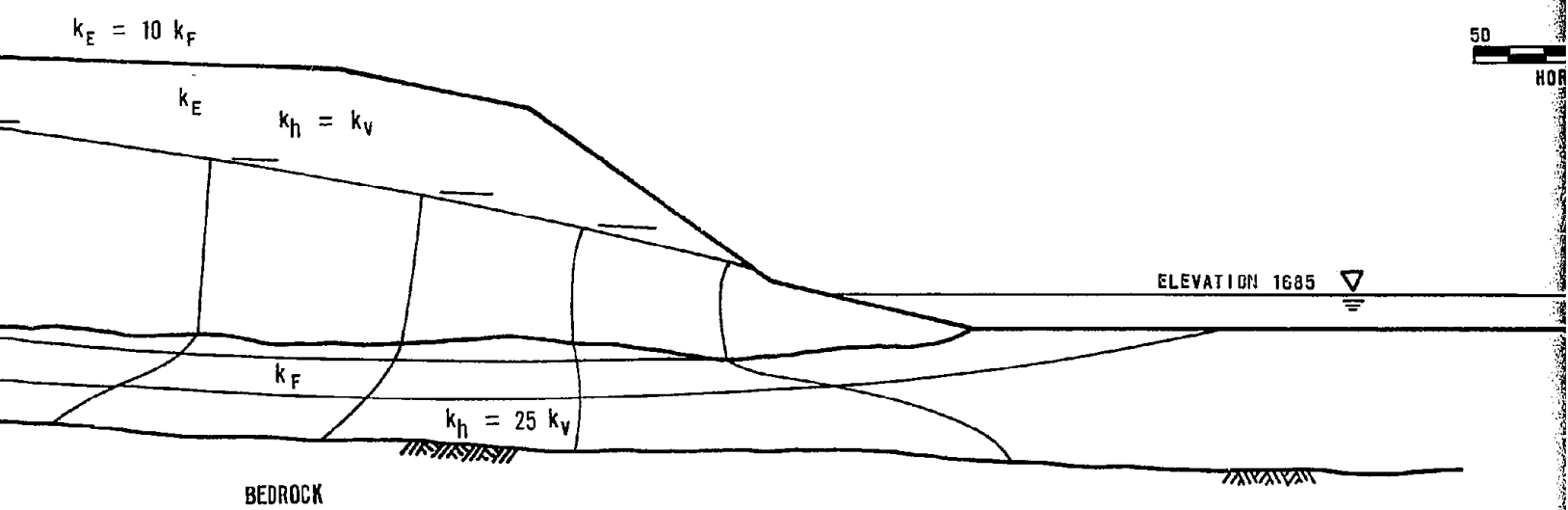

ANISOTROPIC PERMEABILITY RATIO = 25; HIGH RESERVOIR LEVEL

W. A. WAHLER & ASSOCIATES	COAL REFUSE DAM FAILURE SAUNDERS, WEST VIRGINIA	SECTION
	PALO ALTO • NEWPORT BEACH • CALIF.	PROJECT NO. 0700

- NOTES: (1) EQUIVALENT EMBANKMENT PERMEABILITY = $k_E = k_h = k_v$
 EQUIVALENT FOUNDATION (SLUDGE) PERMEABILITY = $k_F = \sqrt{k_v \times k_h}$
- (2) FOR MORE DETAILED INFORMATION ON PERMEABILITY DATA SEE CHAPTER VII, SECTIONS B AND E, AND APPENDIX B.
- (3) THESE SECTIONS ARE DRAWN TO TRUE SCALE. THE ORIGINAL FLOW NETS WERE DRAWN ON TRANSFORMED SECTIONS WHICH WERE CONSTRUCTED BY EXPANDING THE DEPTH OF THE FOUNDATION BY A FACTOR OF $\sqrt{k_h/k_v}$
- (4) FIGURE VII-20 DEMONSTRATES THE USE OF FLOW NETS IN PORE PRESSURE DETERMINATION FOR STABILITY ANALYSIS.

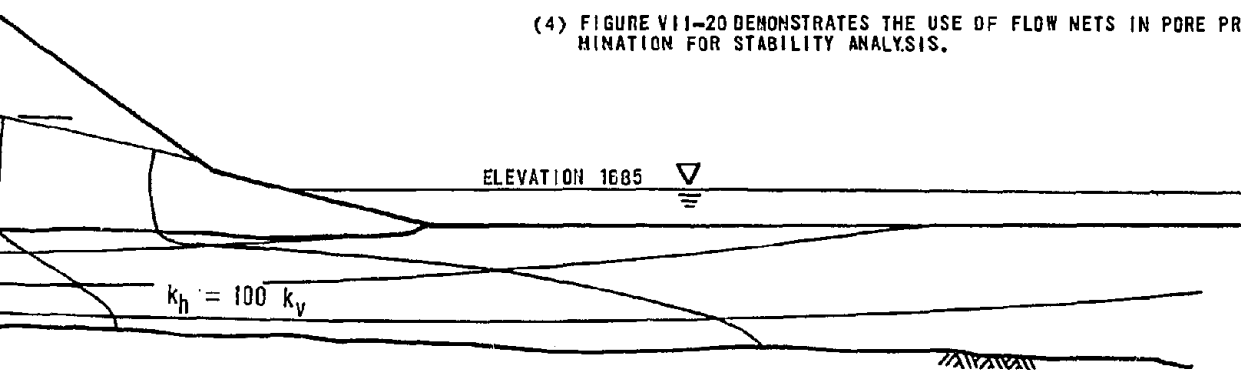

= 100: HIGH RESERVOIR LEVEL

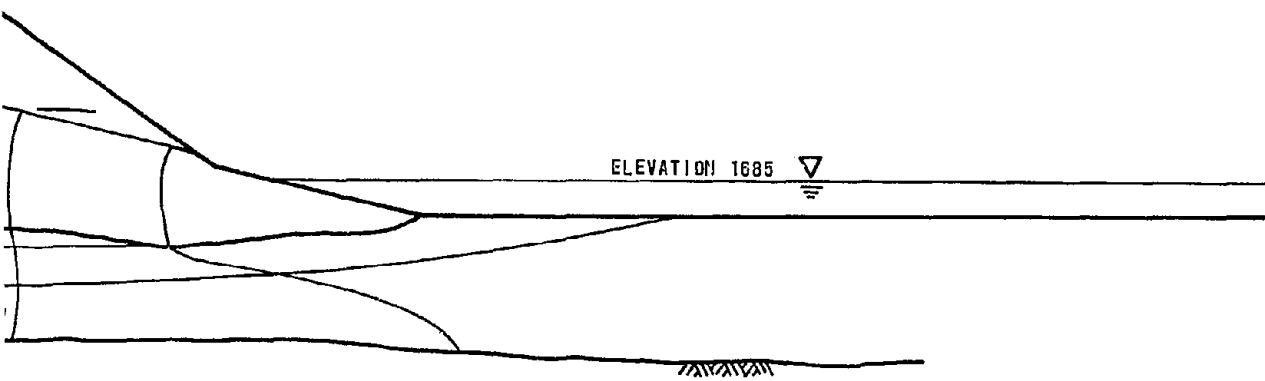

= 25: HIGH RESERVOIR LEVEL

W. A. WAHLER & ASSOCIATES	COAL REFUSE DAM FAILURE SAUNDERS, WEST VIRGINIA PALO ALTO • NEWPORT BEACH • CALIF.	SECTION F-F' FLOW NETS - MAXIMUM POOL COAL WASTE DAM NO. 3		
		PROJECT NO. 0700	DATE NOVEMBER 1972	FIGURE NO. VII-19

In examining the flow nets, however, it must be realized that the head loss between adjacent equipotential lines is 7.1 feet for the normal Pool 3 level and 9.7 feet for the maximum Pool 3 level. The head loss per drop (from one equipotential line to the next) directly affects the pore pressures as indicated in Part 4 of this section.

The ratio of embankment to foundation permeabilities (k_E / k_F) was taken to be 10 where $k_E = k_v = k_h = 2 \times 10^{-4}$ cm/sec, and $k_F = \sqrt{k_v k_h} = \sqrt{(4 \times 10^{-6}) (1 \times 10^{-4})} = 2 \times 10^{-5}$ cm/sec. For the above ratio, one flow line or stream line in the embankment is equal to ten flow lines in the foundation when considering quantity of seepage.

The flow nets were constructed on transformed sections by expanding the dimension of lesser permeability within the foundation. The resulting size of these sections therefore made it impractical to include them herein. As is evident from the flow nets presented, the flow lines and equipotential lines shown on the true section of a hydraulically anisotropic material are not mutually orthogonal as they would be for a transformed section.

The flow nets allowed qualitative and quantitative analyses of the seepage gradient and pore pressure at several points in the dam cross section, as explained below and in the following section on stability analysis.

As shown on Figure VII-16, the exit gradients along the flow paths within the foundation sludge beneath Dam No. 3 for normal Pool 3 reservoir elevation of 1,735, were 0.30 and 0.22 for the two anisotropic foundation permeability ratios considered. The theoretical critical gradient for the development of piping is defined by the following expression:

177

$$i_{cr} = \frac{G-1}{1+e}$$

where i_{cr} = critical gradient for the development of piping

G = specific gravity (average value of foundation sludge = 1.43)

e = void ratio (average value of foundation sludge = 0.65)

As shown above, the critical gradient of the foundation sludge is approximately 0.26 as compared with a similar value of the embankment material of 0.70. Comparing the theoretical critical gradient occurring within the foundation sludge material with values obtained from the flow net analyses, the indicated factor of safety against the occurrence of piping is 0.87 and 1.18 for the two permeability ratios studied. It is apparent, therefore, that a condition of marginal stability with regard to piping existed within the foundation sludge even at the normal pool elevation of 1,735. It should be noted, however, that the calculated exit gradients are predicated on the idealized cross sections used. It is quite possible that a neat line separating the foundation sludge and coarser embankment materials did not exist in reality because of minor sloughing of the embankment material near the toe, previous failures of the embankment which displaced the sludge, and differential settlements of the embankment due to variable foundation thicknesses. Any of these conditions would tend to increase the critical gradient because of the presence of more embankment material; however, with such low factors of safety against piping, and a recognition of previous occurrences of piping, there is little doubt that the foundation sludge material existed in a metastable condition.

As the Pool 3 reservoir level rose during January and February, conditions favoring the development of piping grew worse as a direct result of the increased difference in elevation between Pool 3 and Pool 2. The seepage gradient acting within the foundation sludge beneath the toe

area of Dam No. 3 for the estimated flood stage of Elevation 1,753 is shown on Figure VII-17. For the two anisotropic foundation permeability ratios considered, namely, 100:1 and 25:1, the exit gradients are shown to be 0.38 and 0.27 resulting in factors of safety with respect to piping of 0.68 and 0.96, respectively. There is little doubt, therefore, that the entire central 270 feet of foundation sludge material underlying the downstream toe area of Dam No. 3 was actively developing piping conditions prior to or at the time of failure. However, neither the field evidence nor the engineering analyses substantiate this condition as the principal cause of the catastrophic failure of the dam for the following reasons:

- a. If a severe piping condition had developed, large internal erosion channels (pipes) would have been created beneath the embankment. As these pipes began to progress in an upstream direction they would have enlarged and branched in such a manner that large sections of the embankment would have collapsed into the void space created by the piping action. The resulting collapse of the embankment into the foundation would have temporarily halted the piping action until the seepage diverted itself around the blockage and once again concentrated in another area to repeat the entire process. This process would have ultimately progressed until the dam had settled to the Pool 3 water elevation and then failed by overtopping. The approximate total time of failure of 15 minutes is not consistent with the time required for the full development for such a mode of failure.

The field evidence, as determined from the extensive exploratory drilling program, clearly indicates that a major portion of the upstream section of the embankment remained intact below the observed postfailure ground surface. As shown

on Figure VI-21, Geologic Section A-A', approximately 300 feet of the upstream embankment-sludge foundation contact remained undisturbed, whereas the remaining 220 feet of downstream section, to a depth of about 50 feet, consisted of mixed embankment and foundation sludge material. Similarly, the transverse Geologic Section B-B' shown on Figure VI-22 indicates the contact between the embankment and foundation sludge materials to be level and unbroken. The field determined location and attitude of the undisturbed and mixed materials near the downstream toe of Dam No. 3, indicates that a piping failure in the foundation sludge material could not have produced the observed postfailure materials distribution.

It cannot be stated with any degree of certainty exactly how extensively the piping condition had developed prior to the time of failure. It is known, however, that the embankment and foundation were extremely vulnerable to more than one potential failure mode because of the high foundation pore pressures associated with the full reservoir condition just prior to failure. Furthermore, regardless of whether or not any piping was in progress just prior to failure, the embankment would have failed in a different mode, as discussed in Subsection 4, below. This fact, combined with our evaluation of the postfailure physical evidence at the site, leads us to conclude that, while piping was undoubtedly in progress just prior to failure, this phenomena was only one of several contributing factors to the principal mode of failure.

4. Shear Failure

The stability of Dam No. 3 was evaluated utilizing a computer program developed by W. A. Wahler and Associates. The program logic follows a total unit weight and boundary water force concept which is customarily referred to as the effective stress method. Data input for this method consists of effective stress, shear strengths, unit weights, and

piezometric water pressure values. The engineering properties used for these stability analyses are presented in Section B of this chapter, and the method of pore pressure determination is described later in this section. A complete discussion of the methods of analyses is presented below.

a. Conventional Slip-Circle Analyses

There currently exist at least three methods for determining the factor of safety for assumed failure surfaces: (1) the conventional method of slices (Fellenius method), (2) the simplified Bishop method, and (3) the Janbu or Morgenstern method. All three methods incorporate the basic geometry of the slope, unit weights and shear strength characteristics of the materials comprising the embankment/foundation, and the distribution of boundary and internal water forces. After a circular failure arc is assumed, the soil mass above the sliding surface is divided into a series of vertical slices. Forces acting on each slice include the earth pressure on the sides of the slice, water pressures on the sides and bottom of each slice, effective earth forces with associated friction acting across the assumed sliding surface, and cohesion along the sliding surface. Results from the three methods vary because of assumptions made regarding the direction of action of the various forces. Although all three analyses were performed for Dam No. 3, only methods (1) and (2) were considered necessary to accurately determine the dam stability. The difference in computed factors of safety for the first two methods referenced is usually less than 10 percent, with the simplified Bishop analysis usually providing the slightly higher value. The differences are particularly pronounced when analyzing for deep-seated failure arcs and high pore pressure differentials. The specific stability results for the various cases analyzed are presented on Figures VII-21 and VII-22. A detailed description of the methods used follows.

Conventional (Fellenius) Method of Slices - In this method, it is assumed that forces acting on the sides of any slice have zero resultant in the direction parallel to the failure arc for that slice. In other words, the forces acting on the sides of the slices are in equilibrium (equal and opposite in direction to each other), and only the forces on the base of the slice acting normal and tangentially to the assumed failure arc need be considered. The weight vector for each slice consists of the moist weight of soil above the water table plus the saturated weight of soil below the water table. The normal component of the weight vector is reduced by the pore pressure acting on the base area of each slice. The resisting force is the sum of the cohesion along the bottom of the slice and the normal component of the weight vector times the tangent of the angle of shearing resistance. The driving force is the tangential component of the weight vector. The factor of safety is calculated by dividing the moment of resistance offered by the cohesion and friction on the failure surface by the driving moment of the soil mass about the center of the assumed failure arc. Many trial failure arcs are analyzed until a minimum factor of safety is obtained.

Simplified Bishop Method - In this newer method, it is assumed that the forces acting on the sides of any slice have zero resultant in the vertical direction. This method also assumes that the forces acting on the sides of each slice are in equilibrium; however, the more exact assumption regarding the summation of forces in the vertical direction requires that an iterative technique be used to calculate the factor of safety. Factors of safety are again obtained by comparing the resisting and driving moments as discussed above.

Janbu or Morgenstern Method - This method considers complete static equilibrium for all internal forces between slices and is a rigorous mathematical solution to the slope stability analysis. Again, an iterative technique is necessary to determine the factor of safety and

usually the only significant differences in results between this method and the simplified Bishop method occur when determining the influence of high seismic force coefficients.

b. Sliding Wedge or Block Failure

Where circular failure arcs did not adequately define potentially critical failure surfaces, wedges or blocks were analyzed. The analysis for this type of failure is the same as that used for circular failure arcs, with slight modification of the computer program. The wedge is divided into slices and the same methods described above are applied. Many simplified wedges were also analyzed by hand calculations using total unit weight and boundary water forces.

c. Discussion of Stability Analyses

The initial stability analyses were performed for the downstream face of Dam No. 3 with a pool elevation of 1,735 in order to determine the minimum factor of safety for the embankment under normal reservoir loading conditions. As stated previously, because of the variable thickness of sludge comprising the foundation, it was considered necessary to perform detailed stability analyses on both transverse sections E-E' and F-F' (Figures VII-12 and VII-13) in order to ascertain what influence, if any, the foundation thickness could have on the embankment stability. Additionally, because of the horizontal stratification of the foundation sludge, stability analyses were performed incorporating pore pressures determined from the flow net diagrams for the two anisotropic foundation permeability ratios of 25:1 and 100:1.

The influence of the foundation permeability ratio on the developed pore pressures is readily seen by an examination of the flow nets for each case. Shown on Figure VII-20 is a quantitative comparison of piezometric head within the foundation for Pool 3 elevation of 1,753.

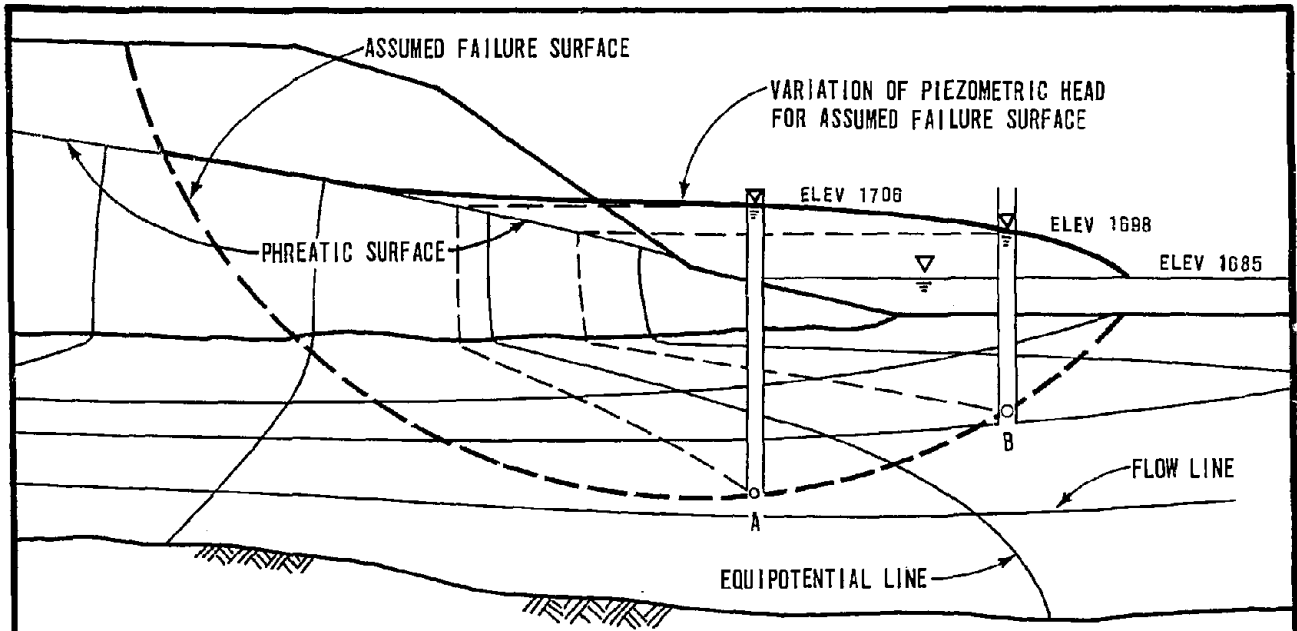

HIGH RESERVOIR LEVEL ANISOTROPIC PERMEABILITY RATIO = 100

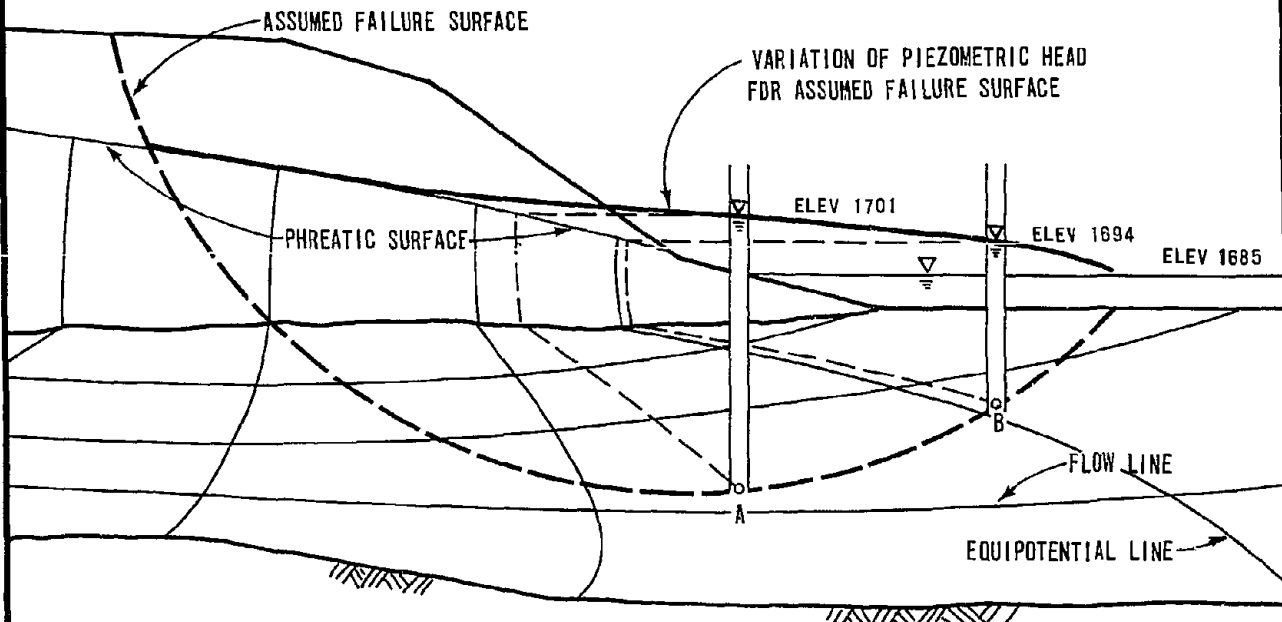

HIGH RESERVOIR LEVEL - ANISOTROPIC PERMEABILITY RATIO = 25

- NOTES: (1) THE EFFECTIVE STRESSES USED FOR THE STABILITY ANALYSIS WERE CALCULATED BY REDUCING THE TOTAL STRESS BY THE APPROPRIATE PORE PRESSURE AS DETERMINED FROM THE PIEZOMETRIC HEAD.
- (2) PIEZOMETRIC HEAD SHOWN APPLIES TO THE SPECIFIC FAILURE SURFACE ONLY.
- (3) PERMEABILITY RELATIONSHIPS OF THE EMBANKMENT AND FOUNDATION MATERIALS ARE THE SAME AS THOSE INDICATED ON FIGURE VII-17.

W. A. WAHLER & ASSOCIATES	COAL REFUSE DAM FAILURE SAUNDERS, WEST VIRGINIA			DETERMINATION OF PIEZOMETRIC HEAD MAXIMUM RESERVOIR LEVEL		
	PROJECT NO.	DATE	FIGURE NO.			
	0700	NOVEMBER 1972	VII-20			
PALO ALTO • NEWPORT BEACH • CALIF.						

Following the dashed line from Point A, in a direction parallel to the adjacent equipotential line, to the intersection with the phreatic surface gives the correct piezometric head for that point. If this method is used for a number of points, the variation in the piezometric head for the assumed failure surface can be developed as shown on Figure VII-20. It is interesting to note that the actual piezometric head at a given point may be considerably different than that which would be determined solely by the difference in elevations of the point in question and the phreatic surface vertically above it. Also, the piezometric head at a given point varies with different assumed values of foundation anisotropic permeability ratio. The computer program developed by W. A. Wahler and Associates and utilized in these analyses, is capable of incorporating variations in piezometric head in both vertical and horizontal directions, thus permitting a rapid and efficient analysis of a large number of potential failure surfaces.

Although a rapid increase in reservoir level theoretically does not result in an instantaneous and complete readjustment of the phreatic surface, it does increase the pore water pressures very rapidly, because of the incompressible nature of water. Therefore, for evaluating pore water pressure or piezometric head, it was appropriate to construct flow nets with phreatic surfaces resulting from the critical Pool 3 level.

Normal Pool 3 Level - The results of the stability analyses for sections E-E' and F-F' of Dam No. 3 for normal Pool 3 elevation of 1,735, are presented on Figures VII-21 and VII-22, respectively. Although results are presented for two anisotropic permeability ratios, the following discussion will concentrate on the results obtained for the ratio of 25:1. As discussed earlier in this Chapter, the range of horizontal to vertical permeability of the foundation sludge varied from about 16:1 to 100:1 with an average value between 25:1 and 36:1. For this reason, the conclusions regarding the embankment stability

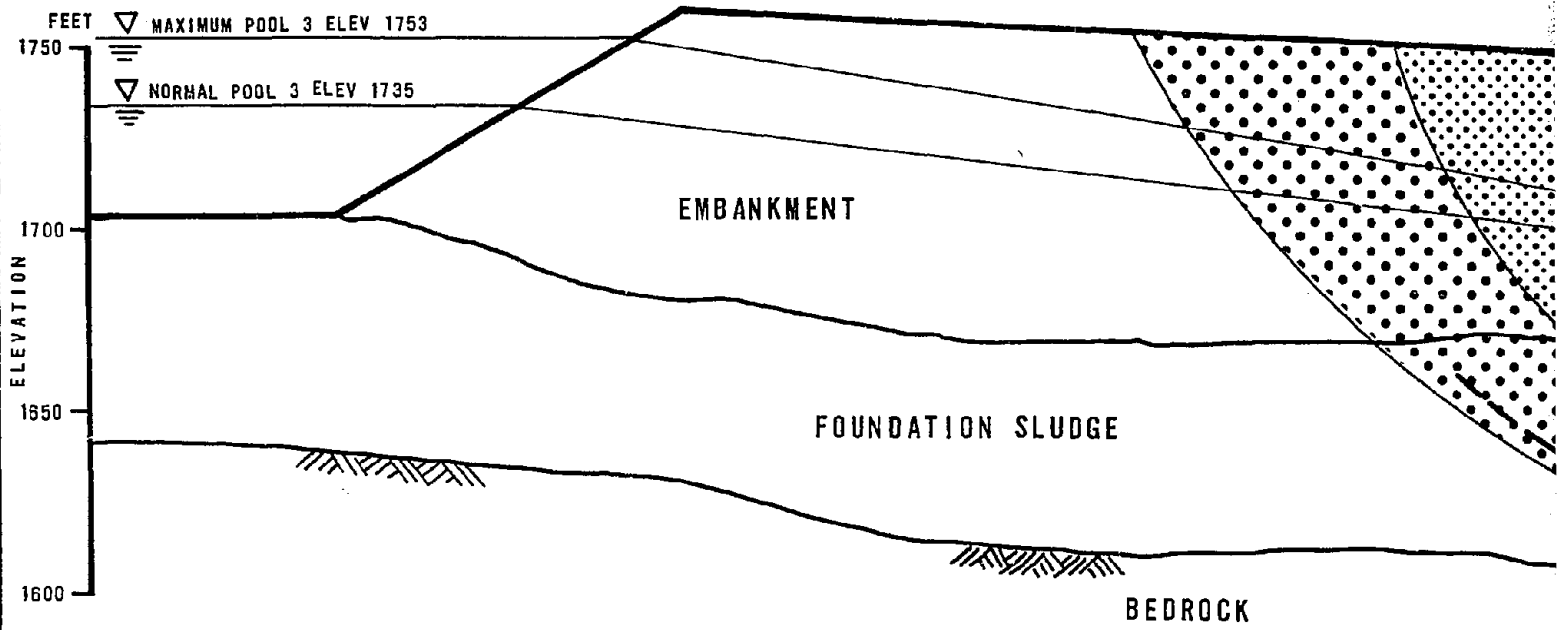

SECTION E-E' COAL WASTE DAM NO. 1

RESULTS OF STABILITY ANALYSIS

BAND		RANGE OF FACTOR OF SAFETY - EFFECTIVE STRESS							
		NORMAL RESERVOIR LEVEL (ELEV 1735)				HIGH RESERVOIR LEVEL (ELEV 1753)			
		$k_h/k_v = 100^{(2)}$		$k_h/k_v = 25^{(2)}$		$k_h/k_v = 100^{(2)}$		$k_h/k_v = 25^{(2)}$	
		CONVENTIONAL	BISHOP'S	CONVENTIONAL	BISHOP'S (3)	CONVENTIONAL	BISHOP'S	CONVENTIONAL	BISHOP'S (3)
①		1.11-1.71	1.14-1.95	1.15-1.69	1.19-1.94	0.99-1.52	0.96-1.75	1.05-1.53	1.05-1.75
②		0.82-0.97	0.77-0.94	0.91-1.04	0.94-1.06	0.70-0.87	0.60-1.06	0.77-0.92	0.73-0.85
③		0.90-1.10	0.90-1.26	0.96-1.24	1.09-1.24	0.77-0.94	0.75-1.09	0.85-1.03	0.91-1.02

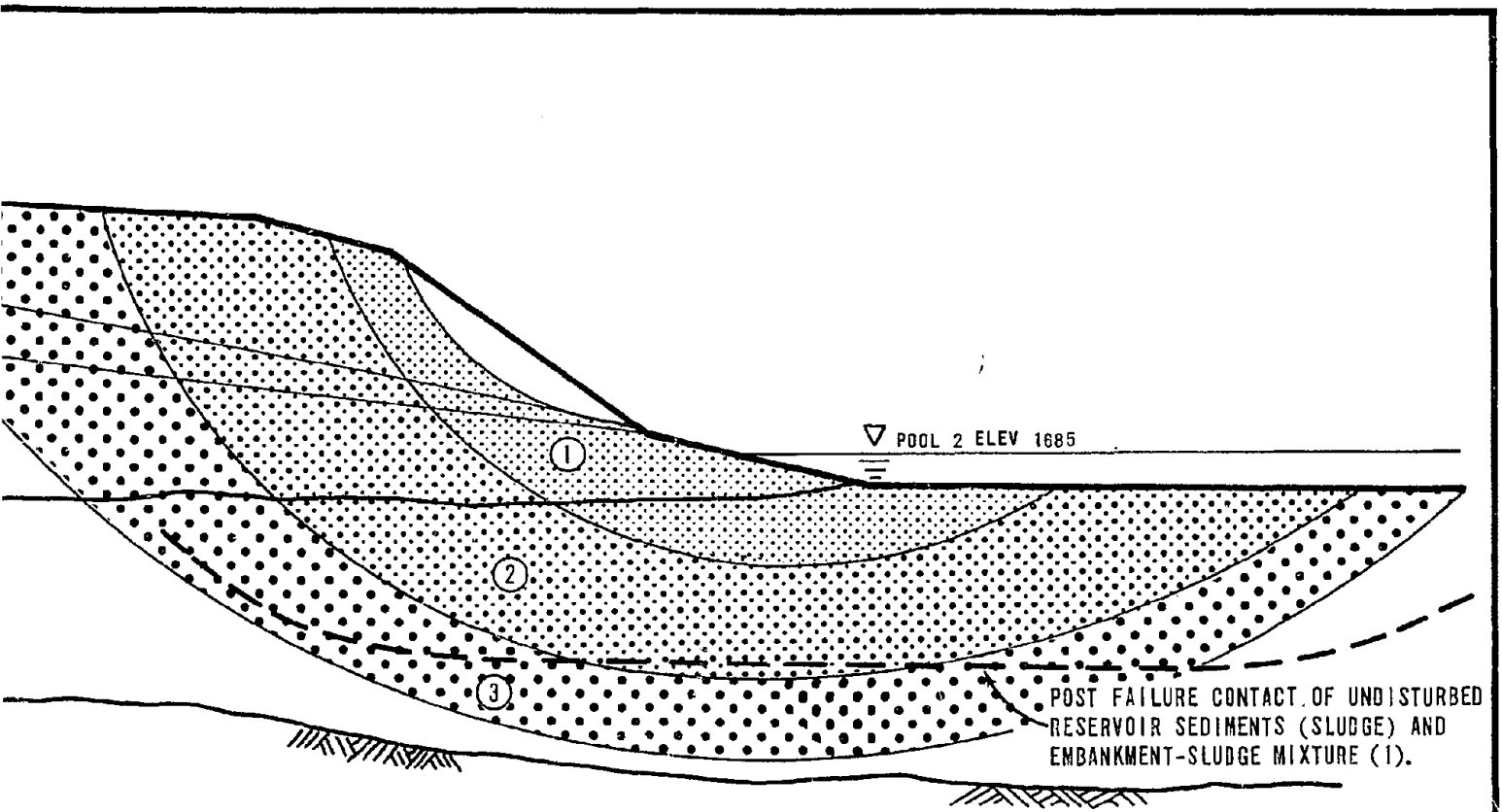

WASTE DAM NO. 3

SCALE

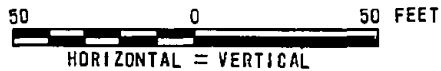

- NOTES: (1) THIS CONTACT WAS ESTABLISHED IN THE FIELD BY EXPLORATORY DRILLING.
 (2) RATIO OF HORIZONTAL TO VERTICAL PERMEABILITY WITHIN THE FOUNDATION (SLUDGE) MATERIAL.
 (3) MOST PROBABLE RANGE IN FACTORS OF SAFETY FOR THE THREE FAILURE ZONES SHOWN.
 (4) THE RESULTS PRESENTED HEREON WERE CALCULATED USING EFFECTIVE STRESS ANALYSIS.
 (5) SEE FIGURE VII-12, FOR MATERIAL PROPERTIES USED IN STABILITY ANALYSIS.

753)
25 ⁽²⁾
BISHOP'S (3)
1.05-1.75
0.73-0.85
0.91-1.02

186

W. A. WAHLER & ASSOCIATES	COAL REFUSE DAM FAILURE SAUNDERS, WEST VIRGINIA	RESULTS OF STABILITY ANALYSIS SECTION E-E'		
		COAL WASTE DAM NO. 3		
PALO ALTO • NEWPORT BEACH • CALIF.		PROJECT NO. 0700	DATE NOVEMBER 1972	FIGURE NO. VII-21

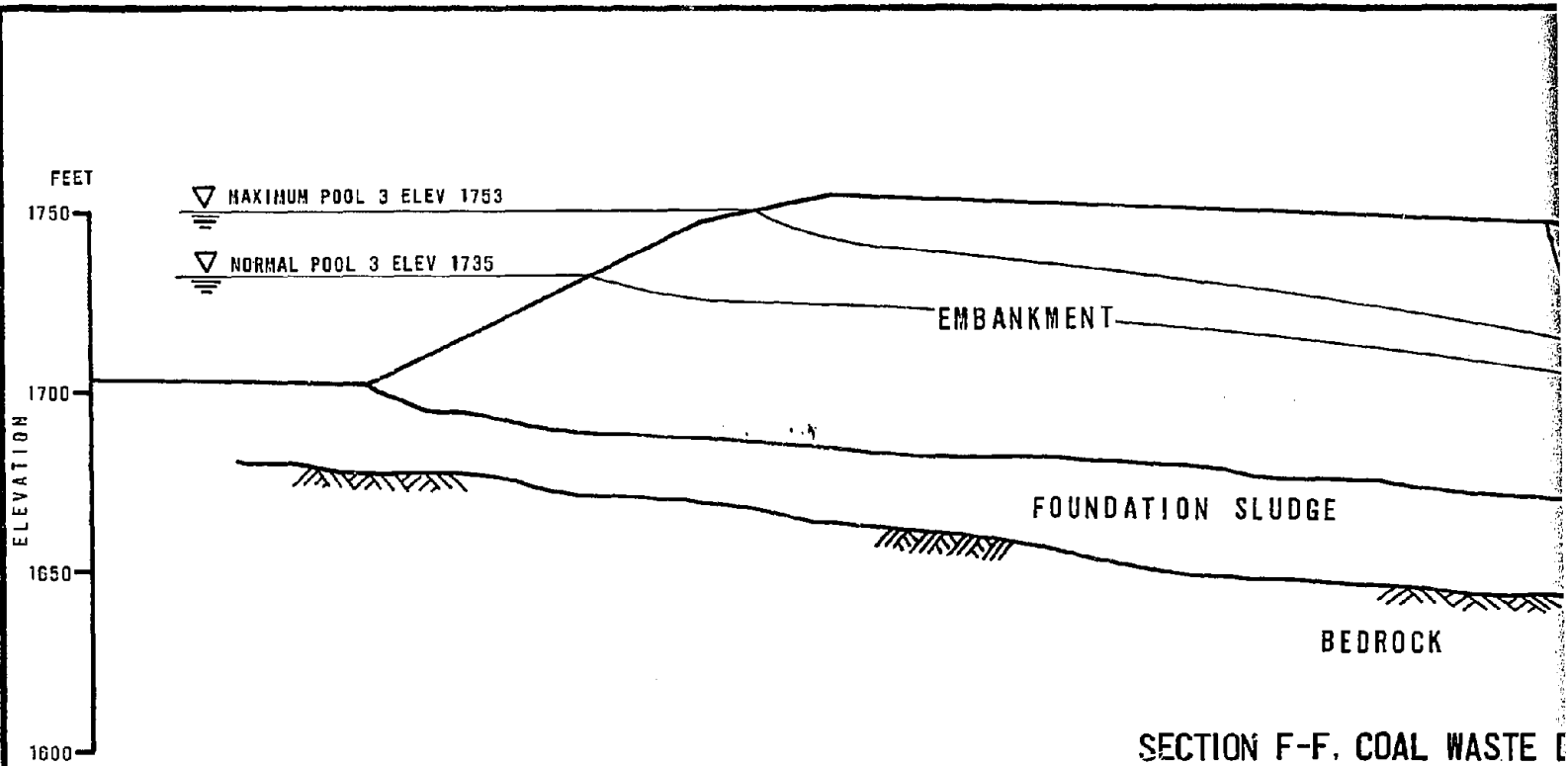

RESULTS OF STABILITY ANALYSIS

BAND		RANGE OF FACTOR OF SAFETY - EFFECTIVE STRESS							
		NORMAL RESERVOIR LEVEL (ELEV 1735)				HIGH RESERVOIR LEVEL (ELEV 1753)			
		$k_h/k_v = 100$ ⁽²⁾		$k_h/k_v = 25$ ⁽²⁾		$k_h/k_v = 100$ ⁽²⁾		$k_h/k_v = .25$ ⁽²⁾	
		CONVENTIONAL	BISHOP'S	CONVENTIONAL	BISHOP'S (3)	CONVENTIONAL	BISHOP'S	CONVENTIONAL	BISHOP'S (3)
①		1.19-1.40	1.29-1.49	1.19-1.40	1.29-1.49	1.12-1.37	1.19-1.45	1.12-1.37	1.19-1.45
②		0.86-1.11	0.84-1.12	0.95-1.13	0.99-1.15	0.76-1.02	0.67-0.99	0.82-1.04	0.78-1.02

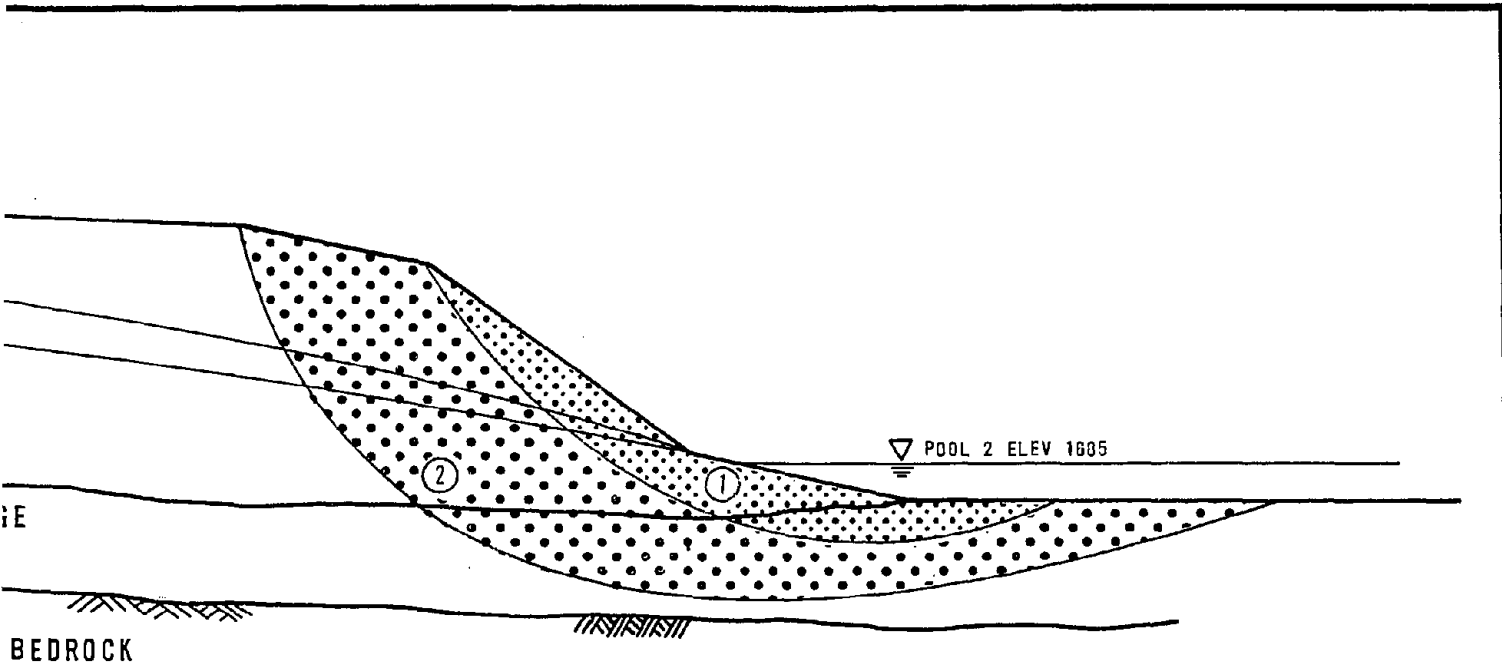

F. COAL WASTE DAM NO. 3

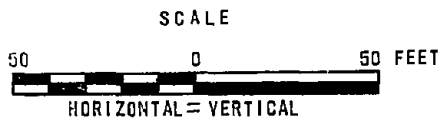

- NOTES:
- (1) THE RESULTS PRESENTED HEREON WERE CALCULATED USING EFFECTIVE STRESS ANALYSIS.
 - (2) RATIO OF HORIZONTAL TO VERTICAL PERMEABILITY WITHIN THE FOUNDATION (SLUDGE) MATERIAL.
 - (3) MOST PROBABLE RANGE IN FACTORS OF SAFETY FOR THE THREE FAILURE ZONES SHOWN.
 - (4) THE RESULTS PRESENTED HEREON WERE CALCULATED USING EFFECTIVE STRESS ANALYSIS.
 - (5) SEE FIGURE VII-13 FOR MATERIAL PROPERTIES USED IN STABILITY ANALYSIS.

(2)
25
SHOP'S
(3)
.19-1.45
.78-1.02

W. A. WAHLER & ASSOCIATES	COAL REFUSE DAM FAILURE SAUNDERS, WEST VIRGINIA	RESULTS OF STABILITY ANALYSIS SECTION F-F'		
		COAL WASTE DAM NO. 3		
PALO ALTO • NEWPORT BEACH • CALIF.		PROJECT NO.	DATE	FIGURE NO.
		0700	NOVEMBER 1972	VII-22

were based on the anisotropic foundation permeability ratio of 25:1. However, the results for the ratio of 100:1 are also presented to indicate the sensitivity of the stability results to the assumed permeability ratio.

As shown on Figure VII-21, which represents conditions for a near maximum foundation thickness, three distinct bands or zones of ranges in factors of safety are noted in the results. The upper band No. 1, which includes rather shallow assumed failure arcs confined primarily within the embankment and extending about 20 feet into the foundation, indicates a range of factors of safety of 1.19 to 1.94 against either circular or wedge-type failure. The middle band No. 2, which includes failure surfaces extending 20 to 50 feet into the foundation, indicates a range of factors of safety of 0.94 to 1.06. Finally, the deep band No. 3, which includes failure surfaces extending 50 to 75 feet into the foundation, indicates a range of factors of safety of 1.09 to 1.24.

As shown on Figure VII-22, which represents conditions for the approximate average foundation sludge thickness (Section F-F'), only two distinct bands or zones of ranges in factors of safety are noted in the results. The upper band No. 1 is similar to the same band discussed above for Section E-E', except the indicated factors of safety against either circular or wedge-type failure are slightly higher and range between 1.29 and 1.49. The deeper, more critical band No. 2, which includes failure arcs extending about 10 to 25 feet into the foundation, indicates a range of factors of safety of 0.99 to 1.15, or four to eight percent higher than the similar band No. 2 for Section E-E'.

Two additional stability analyses were also performed for Dam No. 3: (1) assuming a nominal 10-foot thickness of foundation sludge material, and (2) assuming the embankment to be underlain only by a relatively thin section of unstripped soil cover overlying the bed-rock surface. The latter analysis actually represents a condition

which probably existed for 50 to 60 percent of the crest length of the dam. The results of these analyses indicate that the factors of safety against either circular or wedge-type failures were 1.11 and 1.29 for cases 1 and 2, respectively.

The stability results for Dam No. 3 at normal pool elevation 1,735 indicate that the downstream face of the embankment was at best only marginally stable. The calculated minimum factor of safety of 0.94, for the condition of maximum thickness of foundation sludge, at first seems somewhat paradoxical; however, this factor of safety does appear to be consistent with the assumed parameters and geometric configuration of Dam No. 3 for the following reasons:

- a. As indicated by the results for the two cross sections shown, and the additional cross sections referenced, the factor of safety against the shear failure is increased from 0.94 to 1.29 when the foundation sludge thickness is decreased from approximately 50 to 0 feet. Because the foundation thickness was not constant across the valley, it is quite possible that the more stable abutment sections of the embankment transmitted some additional shearing resistance by a bridging action (three-dimensional effect) to the central area of lower, more critical stability.
- b. As indicated by the difference in results for the two anisotropic permeability ratios assumed, the calculated factor of safety is rather sensitive to the pore pressure distribution within the foundation which, in turn, is a function of the assumed permeability ratio. It is possible that local variations within the foundation sludge could result in a permeability ratio less than 25:1, thereby reducing the developed pore pressures and increasing the factor of safety.

- c. The method of construction by end-dumping and spreading may have resulted in the lower portions of the embankment containing somewhat coarser materials than the upper portions, thereby developing a more pervious zone. The presence of such a pervious zone would tend to act as a horizontal drain near the embankment-foundation contact and reduce the foundation pore pressures, thereby increasing the overall factor of safety in the same manner as discussed in (b) above.

Maximum Pool 3 Level - The stability analyses for the downstream face of Dam No. 3 with the assumed maximum reservoir condition that existed on February 26, 1972, were performed on the same cross sections described above, except the reservoir level was assumed equal to the field-determined high water elevation of 1,753. For this analysis, it was assumed that, because of the saturated condition that existed within the foundation as a result of normal operations, the resulting increase in pore water pressures associated with the higher reservoir level was transmitted instantaneously to the downstream toe area as the reservoir continued to rise.

The stability results for flood stage Elevation 1,753 are presented on Figures VII-21 and VII-22 for embankment cross sections E-E' and F-F', respectively. As discussed in the previous analysis, three distinct bands or zones of factors of safety are noted for section E-E'. These bands also exhibit the same depth of penetration into the foundation sludge as previously discussed. The results indicate that the range of calculated factors of safety against shear failure for band No. 1 was 1.05 to 1.75; for band No. 2 was 0.73 to 0.85; and for band No. 3 was 0.91 to 1.02. Similarly, the results for section F-F' also indicate that two recognizable bands of factors of safety exist with the same depth of penetration for the assumed failure arcs as discussed in the previous analysis. The results indicate that the range of calculated factors of safety against shear failure for band

No. 1 was 1.19 to 1.45 and for band No. 2 was 0.78 to 1.02. The two additional analyses for assumed foundation sludge thicknesses of 10 and 0 feet indicated a minimum factor of safety against shear failure of 1.00 and 1.19, respectively.

As a result of the detailed stability analyses discussed above for Dam No. 3 with the reservoir surface at Elevations 1735 and 1753, the following conclusions were deduced regarding the overall stability of the dam.

- a. The stability of the dam at normal reservoir loading conditions was at best only marginal.
- b. The calculated factors of safety for the highest reservoir loading at Elevation 1753, which probably occurred just prior to failure, indicate a gross instability of that portion of the dam underlain by foundation sludge material. This condition applies to the central 270 feet of the dam.
- c. The location of the failure surface represented by the minimum factor of safety for the high reservoir loading condition coincides remarkably well with the contact, located during the field investigation, separating the undisturbed reservoir sludge and the overlying mixture of embankment-sludge material.
- d. As a result of the unit weight of the saturated embankment material being about 35 percent greater than the foundation material, and the condition of partial liquefaction which existed in the sludge near the downstream toe, a failure of Dam No. 3 could have occurred so rapidly that a large section of the foundation sludge in Pool 2 would have been displaced as a flood wave.

- e. The resulting failure mechanism discussed in (d) would have left an oversteepened downstream face which may have extended as low as the prefailure Pool 2 water surface. Stability analyses for such a condition indicate that essentially rectangular blocks up to 20 feet in width would be rendered unstable under the imposed loading conditions. The resulting progressive failure of successive wedges would be drastically hastened by the emergence of the phreatic surface high on the exposed face. This progression of failure towards the upstream face of the dam would occur rapidly.

F. MOST PROBABLE MODE OF FAILURE

In attempting to establish the most probable mode of failure for Dams 2 and 3, it was necessary to incorporate the large amount of evidence delineated by our field investigation with the appropriate results of the engineering analyses discussed in Section E above. In the following discussion, the various elements of the most probable mode of failure are presented in the sequence in which they occurred.

The overwhelming field evidence, in addition to the engineering analyses, indicates that the initial failure occurred in the downstream section of Dam No. 3 and consisted of a massive slide movement involving approximately 130,000 cubic yards of embankment material. This slide, depicted by band No. 2 on Figure VII-21, occurred in such a manner that the slide mass physically displaced Pool 2 sediments, which were acting as a semi-viscous fluid because of the relatively high internal pore water pressures, and translated a large block of these sediments onto the left side of Dam No. 2. The limits of the displaced Pool 2 sediments are shown in plan view on Figure VI-20 and in cross section on Figure VI-21. Associated with this massive displacement into Pool 2, was the initial overtopping of Dams 2 and 1 by the reservoir water displaced from Pool 2. This surging of water over the crest of Dam No. 2, which

had perhaps only four feet of freeboard, most likely initiated the breach near the right abutment.

Immediately after the initial failure, Dam No. 3 continued to fail rapidly by progressive action. Because the initial failure undoubtedly created a relatively steep head scarp, as depicted by the typical failure surfaces shown on Figure VII-21, that portion of the embankment not involved with the initial failure was left standing with the phreatic surface emerging high on the exposed face. The resulting condition of the embankment was very unstable and the remaining portions of the embankment commenced to slide into the void created by the initial failure. It is impossible to state exactly how long this progressive failure mechanism took to develop, but the total time required to complete this mode of failure is compatible with the approximate 15-minute period within which it is estimated the complete failure occurred.

When the failure had progressed upstream until only 100 to 120 feet of the embankment remained standing, as measured from the upstream toe, our analyses indicate that the remaining section of the embankment then failed violently, thereby allowing the first rush of Pool 3 reservoir water to start its destructive action. The initial release of water was apparently confined, or nearly so, toward the right side of the valley as it progressed downstream. As water flowed through the breach of Dam No. 3, embankment materials that had slumped as a result of the progressive failure, were transported into the Pool 2 area. As the heavily laden flood waters hit Dam No. 2, its breach, started by the initial overtopping, was probably widened and deepened. The initial flood wave then continued downstream, overtopping and destroying the small Dam No. 1 until the water reached the narrow portion of the valley formed between the refuse bank and the No. 5 Mine Road. The initial surge of this flood wave as it hit the burning refuse bank, caused the explosions reported by numerous observers.

After the flood wave reached the refuse bank, the constrictions in the valley cross section caused a backup of water and the high water lines downstream of Dam No. 3 were formed. As water continued to flow through the initial breach of Dam No. 3, the failure of the remaining portions of the dam progressed toward the right and left abutments.

The field evidence supporting the conclusion that the major flood wave was confined to the right side of the valley includes the fact that the flood deposits of the embankment materials from Dams 2 and 3 were generally confined only to this and the Pool 1 area. Furthermore, the roiled area on the left side of Dam No. 2 contained sludge deposits at elevations ranging from 2 to 10 feet higher than the crest of Dam No. 2. Because the original structure of the sludge was preserved in detail in this highly erodible material, it is inconceivable that any major rapid flood flow ever occurred in the roiled area, although it was undeniably inundated by relatively quiescent flood waters associated with the development of the prominent high water line shown on Figure VI-3.

After developing the mode of failure described above, the remaining Pool 3 water continued to flow through the ever widening breach of Dam No. 3. Relatively minor readjustments of major translated blocks of sediment and embankment materials probably occurred at this time, followed by the final emptying of Pool 3.

To aid the reader in following the sequential nature of the most probable failure mode described above, a series of eight diagrammatic sketches is presented on Figures VII-23A through H showing the major elements of the collapse of Dams 1, 2, and 3.

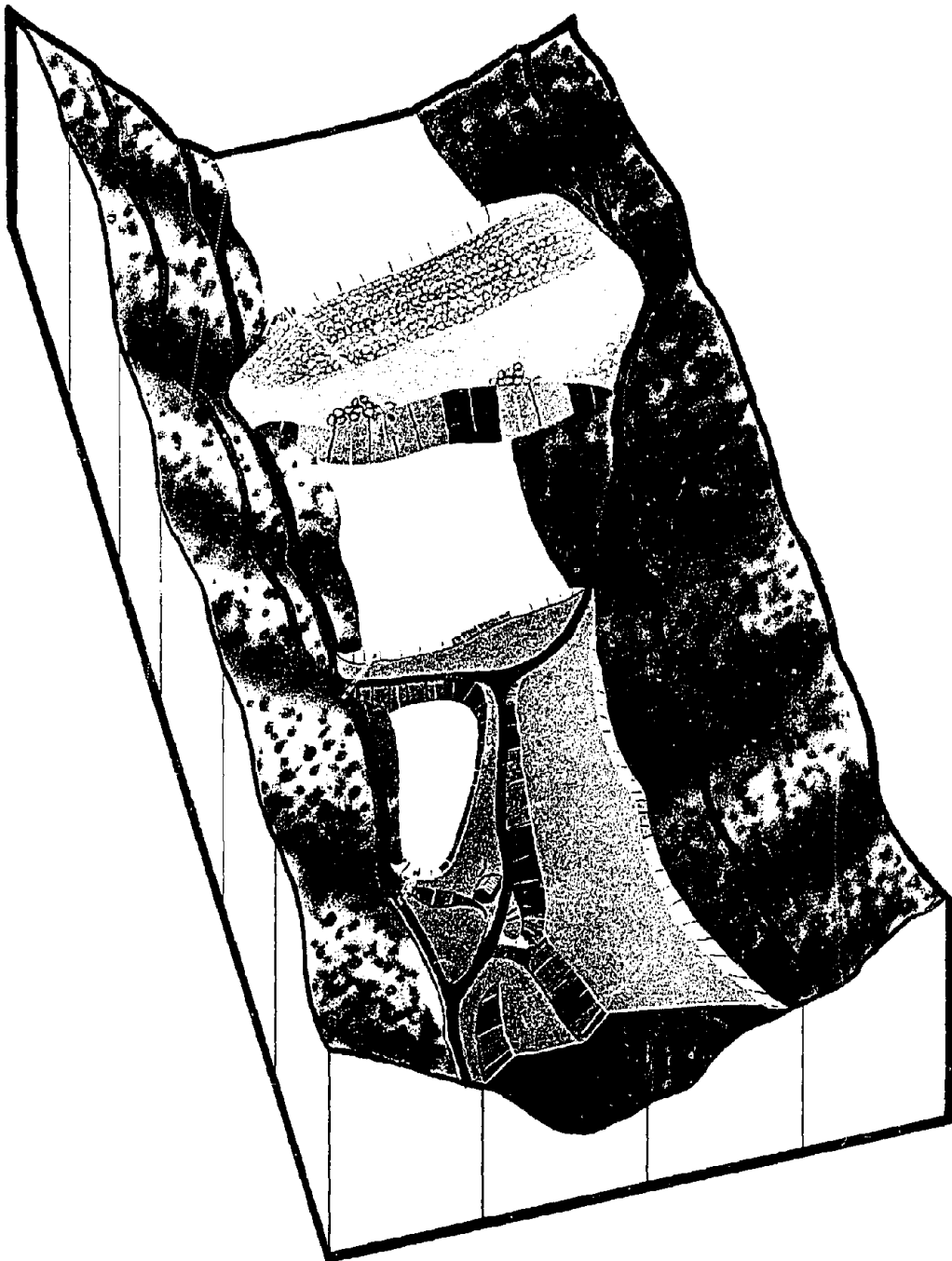

MIDDLE FORK VALLEY IN EARLY FEBRUARY 1972, LOOKING UPSTREAM. POOL 3 HAS A SURFACE ELEVATION OF ABOUT 1740-1745 FEET.

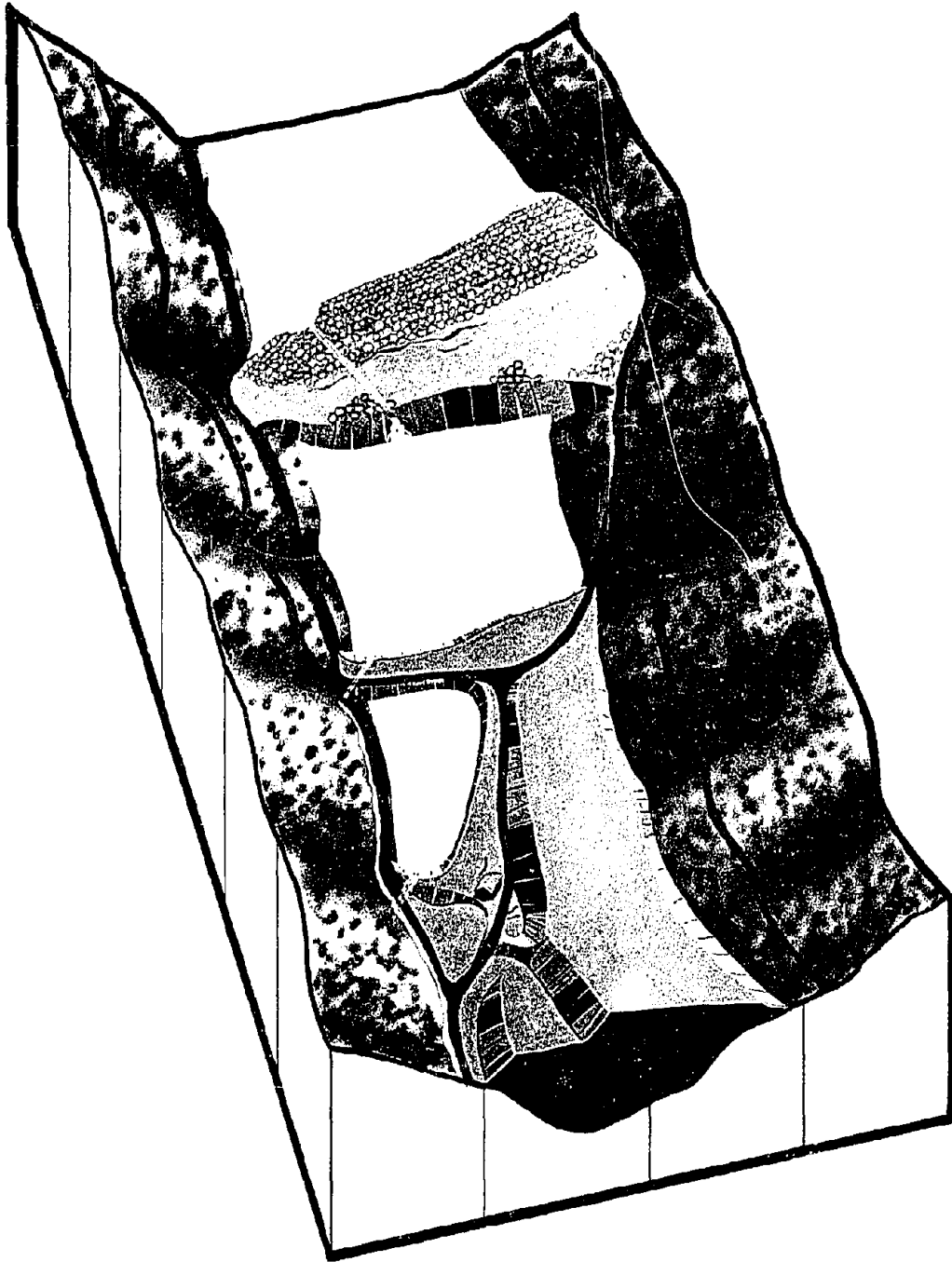

MIDDLE FORK VALLEY, FEBRUARY 26, 1972 SHOWING POOL 3 AT HIGH WATER ELEVATION OF 1753;
EARLY SIGNS OF DISTRESS OF DAM NO. 3 ARE INDICATED BY CRACKS PARALLEL TO CREST.

196



MIDDLE FORK VALLEY, FEBRUARY 26, 1972; INITIAL MASSIVE SHEAR FAILURE OF DAM NO. 3 CAUSING OVERTOPPING OF DAMS 2 AND 1. THE FOUNDATION SLUDGE FROM POOL 2 IS SHOWN TRANSLATED TO LEFT ABUTMENT AREA OF DAM NO. 2.

197

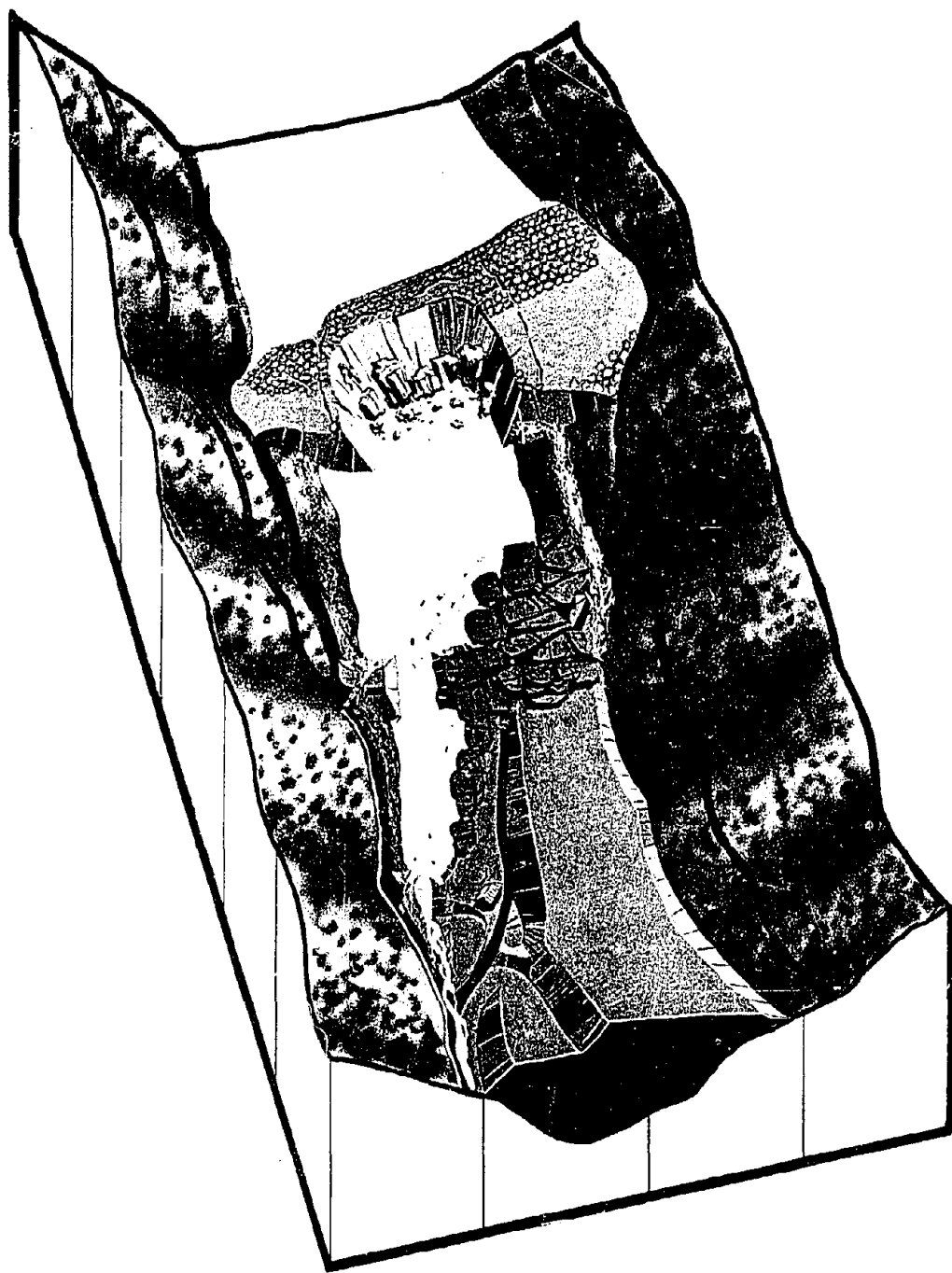

MIDDLE FORK VALLEY, FEBRUARY 26, 1972; PROGRESSIVE FAILURE CONTINUES TO DESTROY REMAINING SECTIONS OF DAM NO. 3; THE INITIAL FLOOD WATER FROM POOL 2 ASSOCIATED WITH SHEAR FAILURE BEGINS TO SUBSIDE EXPOSING THE INITIAL BREACH IN DAM NO. 2.

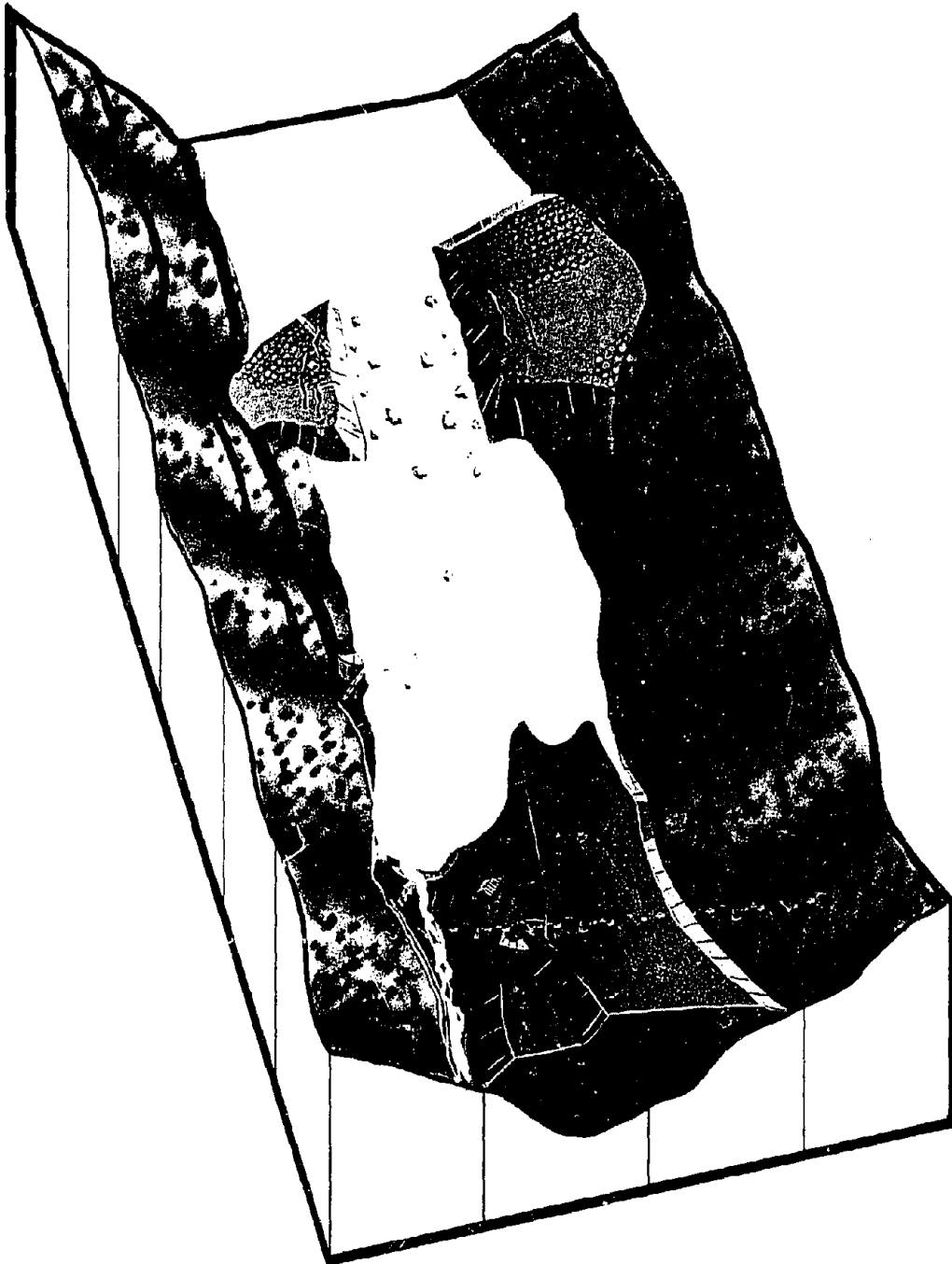

MIDDLE FORK VALLEY, FEBRUARY 26, 1972; CATASTROPHIC FAILURE OF DAM NO. 3 WHICH RELEASES
THE MAJOR FLOOD WAVE.

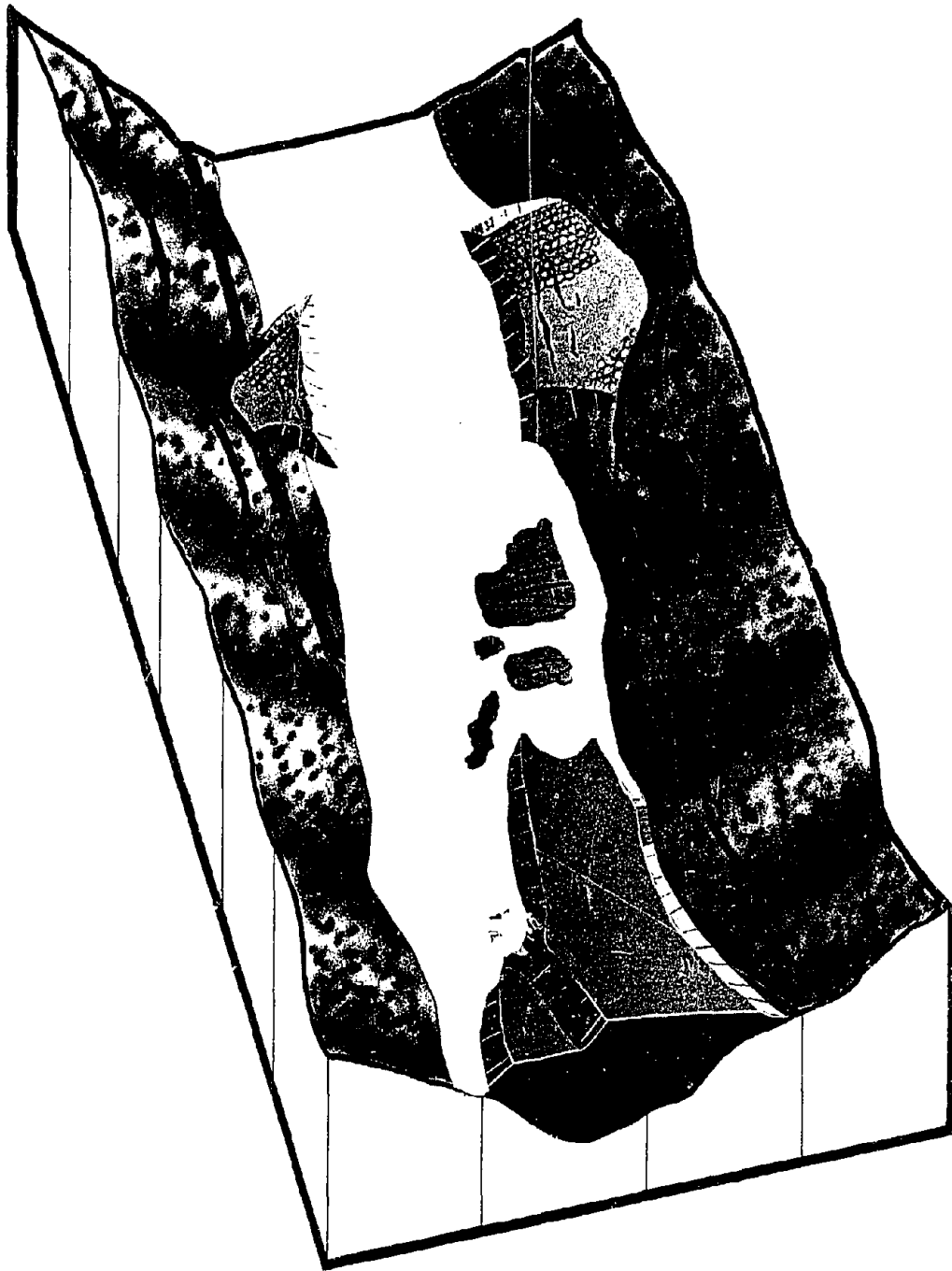

MIDDLE FORK VALLEY, FEBRUARY 26, 1972; FLOOD WAVE OVERTOPS DAM NO. 2 AND DESTROYS DAM NO. 1. BOTH REMNANTS OF DAM NO. 3 CONTINUE TO FAIL BY UNDERCUTTING ACTION OF FLOOD FLOW.

200

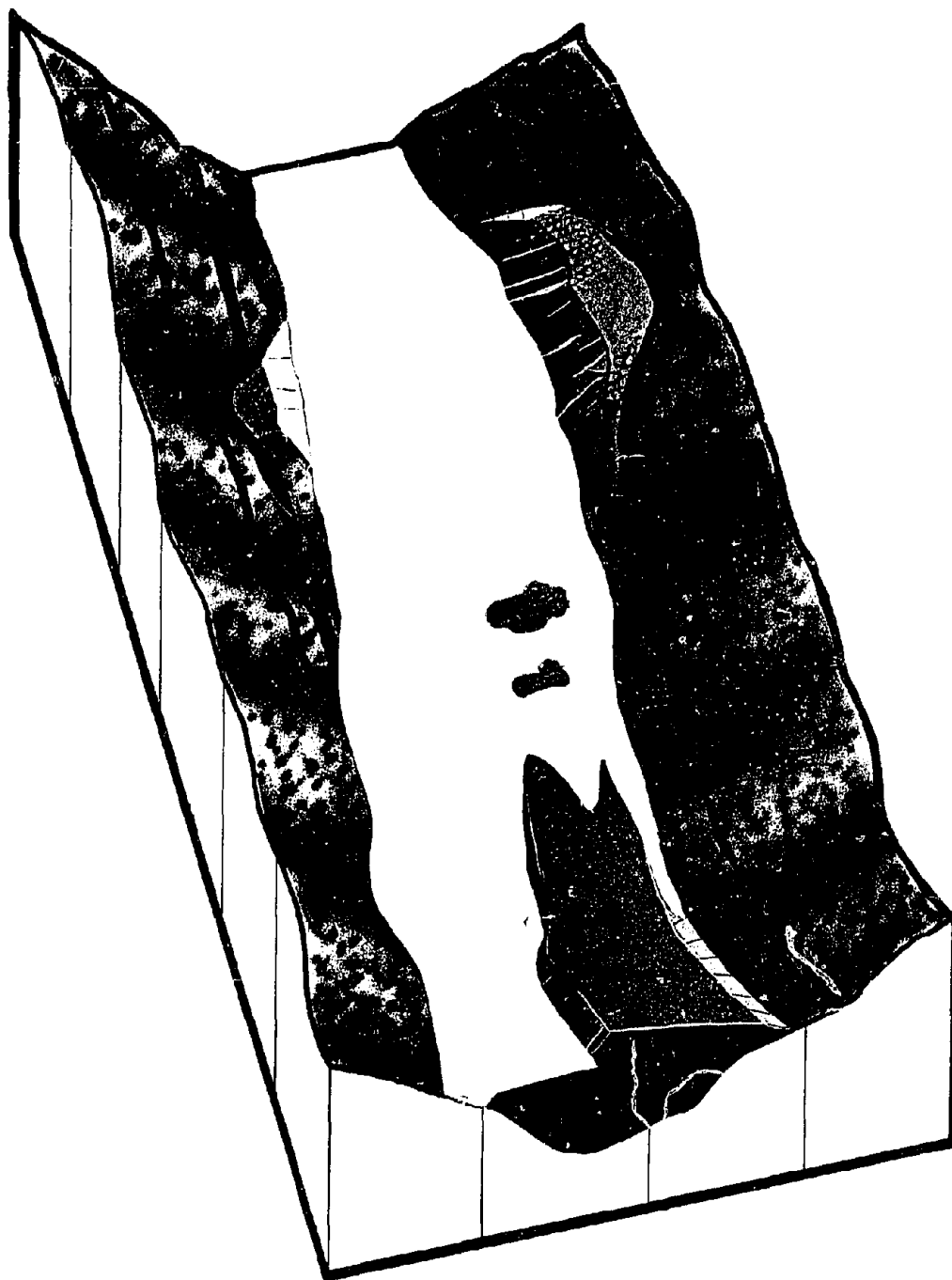

MIDDLE FORK VALLEY, FEBRUARY 26, 1972; HIGH WATER LINE ADJACENT TO REFUSE BANK IS DEVELOPED BY CONSTRICTION OF THE NARROW VALLEY DOWNSTREAM OF DAM NO. 1.

201



MIDDLE FORK VALLEY, FEBRUARY 26, 1972. FAILURE AFTERMATH

202

CHAPTER VIII

FLOOD FLOW AND MATERIALS DISTRIBUTION

A. SOURCES OF FLOOD WATER

As noted in Chapter VII, the February 25-26, 1972 storm was not of a severe nature and would have an expected recurrence interval of two or three years. The degree of storm severity is further demonstrated by the fact that it did not cause unusually high flows in other streams in the area (Table VIII-1). It is concluded, therefore, that the 435 acre-feet of accumulated water behind the coal waste dams on the Middle Fork at Saunders was the source of the catastrophic flooding on Buffalo Creek.

B. PROBABLE ROLE OF REFUSE DAMS AND BANK IN FLOOD DEVELOPMENT AND DISTRIBUTION

Compared to the prefailure volume of Pool 3 (392 acre-feet), the volumes of Pool 2 (30.9 acre-feet) and Pool 1 (12.6 acre-feet) are quite small, and together amounted to only about 10 percent of the total flood water. Had Dams 1 and 2 failed, either alone or in combination, the resulting flood would have been minor, probably similar to that resulting from the failure of Dam No. 1 in 1967, when damage was limited largely to the Saunders area and consisted mainly of minor or moderate damage to houses and roads.

Dams 1 and 2 were essentially ineffective in slowing the flood from Pool 3. However, the configuration of the refuse bank and the valley constriction downstream of Dam No. 1 played an important part in controlling the release of the flood waters into Buffalo Creek Valley. The role of the refuse bank is illustrated by the high water

TABLE VIII-1

FLOODS IN SOUTHWESTERN WEST VIRGINIA
(FROM DAVIES, USGS CIRCULAR 667)

STATION NUMBER	STATE NAMES AND LOCATION	PERIOD OF RECORD	DRAINAGE AREA (SQ. MI)	DISCHARGE DATE							
				MAXIMUM FLOODS OF RECORD			FEBRUARY 1972 FLOOD (PRELIMINARY)				
				DATE	GAUGE HEIGHT (ft)	DISCHARGE (cfs)	RECURRENT INTERVAL (years)	DATE	GAUGE HEIGHT (ft)	DISCHARGE (cfs)	RECURRENT INTERVAL (years)
1985	BIG COAL RIVER AT ASHFORD	1908-16 1930-71	393	8/9/16	36.3	35,800	> 50	2/26/72	23.28	20,600	18
1990	LITTLE COAL RIVER AT DANVILLE	1930-71	270	2/3/39	30.2	42,800	> 50	2/26/72	21.45	14,300	9
2024	GUYANDOTTE RIVER AT BAILEYVILLE	1968-71	208	12/31/69	16.22	18,300	---	2/26/72	17.25	18,500	---
2024.80	BRIAR CREEK AT FENROCK	1969-71	7.20	12/30/69	5.46	485	---	2/24/72 2/26/72	5.57 5.21	512 422	---
(1)	NORTH FORK ABOVE MIDDLE FORK	---	0.85	---	---	---	---	2/26/72	---	80	2
(2)	BUFFALO CREEK ABOVE MIDDLE FORK	---	3.16	---	---	---	---	2/26/72	---	200	2
(3)	BUFFALO CREEK BELOW SAUNDERS	---	6.05	---	---	---	---	2/26/72	---	50,000	40*
(4)	BUFFALO CREEK BELOW STOWE	---	21.0	---	---	---	---	2/26/72	---	13,000	4*
(5)	BUFFALO CREEK ABOVE ACCOVILLE	---	30.8	---	---	---	---	2/26/72	---	8,800	2*

204

* RATIO OF PEAK DISCHARGE TO 50 YEAR FLOOD.

TABLE VIII-1 --CONTINUED
FLOODS IN SOUTHWESTERN WEST VIRGINIA
(FROM DAVIES, USGS CIRCULAR 667)

STATION NUMBER	STATE NAMES AND LOCATION	PERIOD OF RECORD	DRAINAGE AREA (SQ. MI)	DISCHARGE DATE										
				MAXIMUM FLOODS OF RECORD					FEBRUARY 1972 FLOOD (PRELIMINARY)					
				DATE	GAUGE HEIGHT (ft)	DISCHARGE (cfs)	RECURRENT INTERVAL (years)	DATE	GAUGE HEIGHT (ft)	DISCHARGE (cfs)	RECURRENT INTERVAL (years)			
(6)	RIGHT FORK AT ACCOVILLE	---	9.49	---	---	---	---	---	---	2/26/72	---	500	---	2
2030	GUYANDOTTE RIVER AT MAN	1928-71	762.0	3/12/63	24.78	49,000	>50			2/25/72	18.65	29,600	8	
										2/26/72	19.34	31,600	10	
										2/26/72	19.02	30,700	9	
2036	GUYANDOTTE RIVER AT LOGAN	1960-71	836.0	3/12/63	34.98	55,000	>50			2/25/72	26.31	33,900	10	
										2/26/72	27.28	36,100	13	
2040	GUYANDOTTE RIVER AT BRANCHLAND	1915-17 1928-71	1226.0	3/13/63	43.83	44,500	27			2/27/72	41.63	40,800	20	
2070.2	TWELVEPOLE CR. BELOW WAYNE	1928-31 1946-71	300.0	2/4/39	---	22,000	>50			2/26/72	23.19	7,210	2	
2137	TUG FORK AT WILLIAMSON	1967-71	932.0	3/12/63	44.5	---	---			2/25/72	29.75	23,000	3	
2140	TUG FORK AT KERMIT	1934-71	1185.0	3/13/63	45.65	69,600	50			2/26/72	40.25	46,800	8	

* RATIO OF PEAK DISCHARGE TO 50 YEAR FLOOD.

line evidence found on it. The evidence, although vague in some areas, is generally convincing. Figure VI-6 shows a definite high water line at Elevation 1,709 on the left side of the refuse bank near the upper end. Another water line is seen a few feet lower. The overall location of the high water line is plotted on Figure VI-4. Field evidence also indicated that the water may have overtopped a saddle at Elevation 1,709 on the left side of the gob pile during a surge.

Figure VI-25 shows the high water line at other locations. In Photo A, the line is between Elevations 1,711 and 1,712 on the left side of the Pool 2 area. In Photo B, Pool 2 sludge is seen on a tree branch at about Elevation 1,700. Photo D shows a vague, sloping high water line on the refuse bank face to the left of the Pool 1 - Dam No. 1 area. There is smoke coming from the refuse bank at the left, and it is possible that explosions may have occurred in this area as well as further downstream. On Figure VI-27, Photo C shows a portion of a stream terrace developed at Elevation 1,692, about 105 feet west of Hole S-4. A terrace at this elevation indicates that the flood waters flowed here for a period of time sufficient to develop a channel. We estimate that the water in this area, indicated by the open arrow in Figure VI-4, was initially ten feet deep.

Downstream of Dam No. 1, the flood waters were funneled into a narrower part of the valley and were restricted to a channel 100 to 150 feet wide. This constriction, while it caused higher velocities than were prevalent upstream of Dam No. 1, also served to substantially reduce the rate of discharge of flood water onto the Buffalo Creek flood plain below what it would have been if Middle Fork Valley had not been so constricted. The floor of the constriction consisted mainly of the haul road which was paved with well compacted red dog, and thus resisted erosion (Figure VI-2).

Middle Fork had been diverted by Buffalo Mining Company to flow along the right side of the haul road below Dam No. 1. At a point above the curve where the road turned parallel to Buffalo Creek, the discharge from Middle Fork was conveyed under the haul road in a culvert or culverts, and cascaded down a steep chute in the refuse bank (Figure V-18). When the floodwaters reached this cascade area, erosion upstream began and a large notch was cut between the haul road and the refuse bank, removing about 250 feet of the haul road and large amounts of coal refuse as shown on Figure VI-1. Steam and gas explosions occurred when the water encountered the hot and burning coal refuse. Eyewitnesses reported ashes were blown nearly half a mile. Considering the velocity and volume of the flood water, the refuse bank resisted erosion well; otherwise, the flood flow would have been discharged into Buffalo Creek even more rapidly than it was.

C. FLOOD HYDROGRAPHS

The hydrographs of the Buffalo Creek flood developed by the USGS (Davies and others, 1972b) are reproduced here to indicate the severity of the flow, particularly in the upper reaches of Buffalo Creek Valley.

When Dam No. 3 failed, approximately 140 million gallons of water and coal wastes were discharged into Buffalo Creek. Since the time of total discharge from the impoundment was 15 minutes or less, as reported by eyewitnesses, the impact on the Buffalo Creek flood plain was dramatic. The USGS computed the peak discharge in Buffalo Creek below Saunders to have been 50,000 cfs (22 million gpm), resulting in a flash flood with a magnitude at least 40 times that of the 50-year flood for this area.

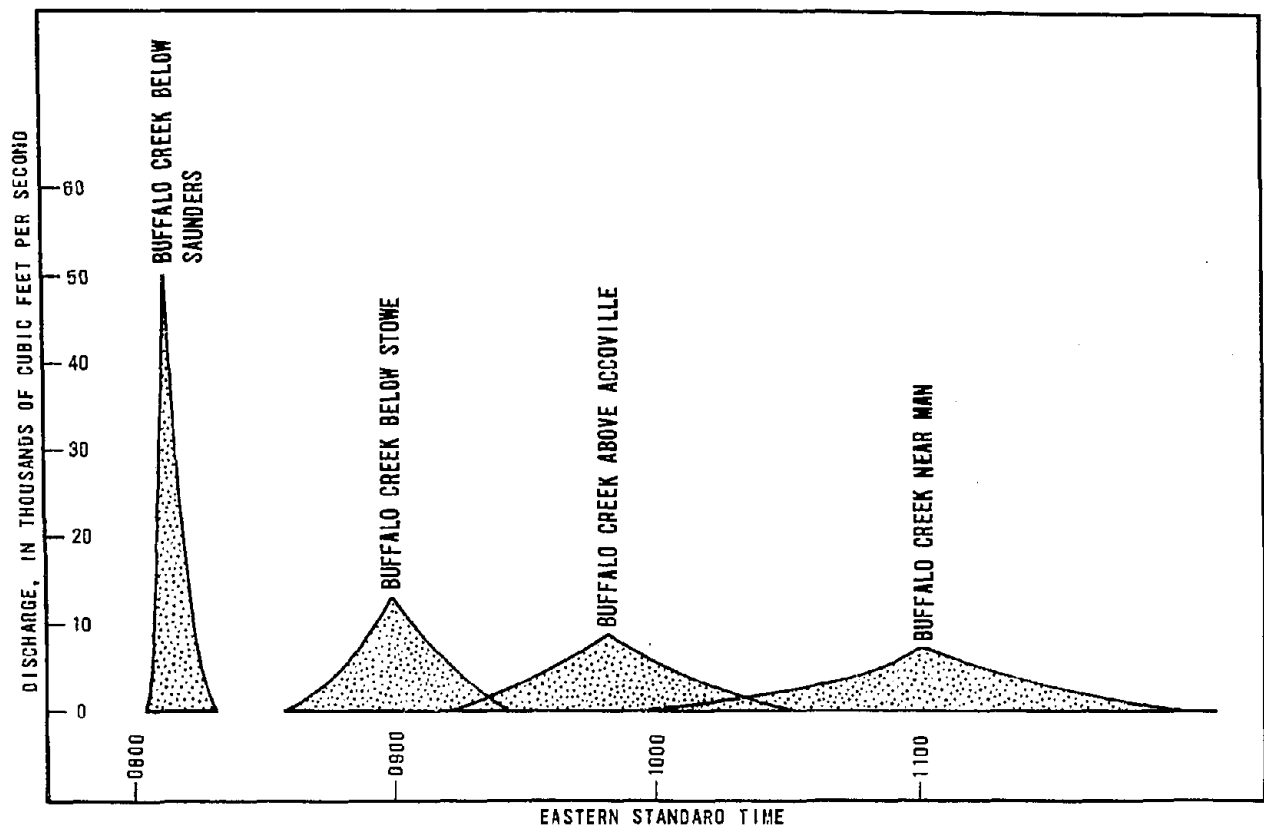

FIGURE VIII-1.—ESTIMATED FLOOD HYDROGRAPHS FOR BUFFALO CREEK BELOW SAUNDERS, BELOW STOWE, ABOVE ACCOVILLE, AND NEAR MAN ON FEBRUARY 26, 1972.

D. FLOOD ATTENUATION

The elevation of Saunders, West Virginia is 1,500 feet above mean sea level; that of Man, West Virginia is 750 feet. Thus, the drop in elevation for the 16-mile path of the flood was 750 feet. However, the initial 3 miles from Saunders to Lorado has a stream gradient of almost 100 feet per mile (1.9%), while the gradient for the remaining 13 miles is approximately 35 feet per mile (0.7%).

The hydrograph shown on Figure VIII-1 indicates the degree of attenuation of the flood as it progressed from Saunders to Man. This attenuation can be attributed to the decrease in stream gradient below

Lorado, the development of debris dams along the downstream flood plain, and some widening of the flood plain in the Accoville area. As a result, peak discharges were significantly reduced as the flood progressed downstream. The time for the flood to pass through Saunders was measured in minutes (probably 5 to 10), through Stowe and Accoville in tens of minutes (20 to 30), and through Man in hours (2 hours). The USGS has estimated mean velocities of the flood waters at 20+ feet per second from Saunders to Pardee, 15 to 20 feet per second below Pardee to Lorado, about 10 feet per second near Accoville, and 5 feet per second or less near Man. Figure VIII-2 indicates the length of time required for the flood crest to reach various downstream communities after the coal waste dam failure. The number of fatalities recorded in each community is also given on Figure VIII-2.

Figure VIII-3 incorporates several data elements concerning the Buffalo Creek flood into a single graphical display. The reduction in gradient can be seen as the stream proceeds from Saunders to Man. Elevations for various localities are indicated, along with the flood height profile as determined by the USGS studies at these points.

E. MATERIALS DISTRIBUTION

Evidence of flood deposition of the material removed from the coal waste disposal area on Middle Fork was found along the entire valley to the town of Man. However, the majority of the material was deposited in the first three miles of the flood plain between Saunders and Pardee, where Toney Fork joins Buffalo Creek from the northeast. The material deposited in this area consisted of coal waste, red dog, and ash materials from the burning portion of the dump.

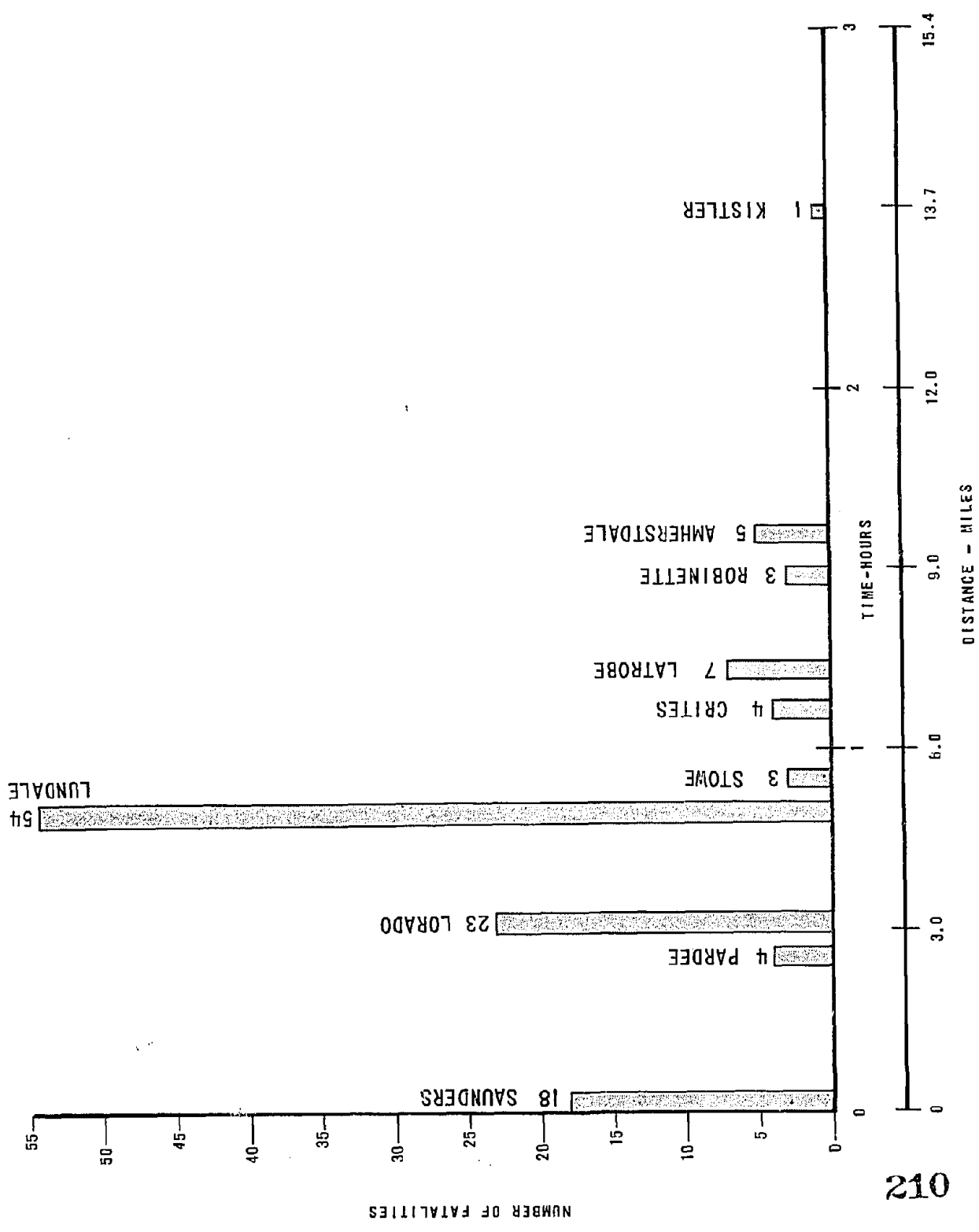

210

W.A. WAHLER & ASSOCIATES

COAL REFUSE DAM FAILURE
SAUNDERS, WEST VIRGINIA

PALO ALTO • NEWPORT BEACH • CALIF.

FATALITY DISTRIBUTION
WITH TIME OF FLOOD AND DISTANCE DOWNSTREAM

PROJECT NO.	DATE	FIGURE NO.
0700	NOVEMBER 1972	VIII-2

ELEVATION ABOVE MEAN SEA LEVEL, IN FEET

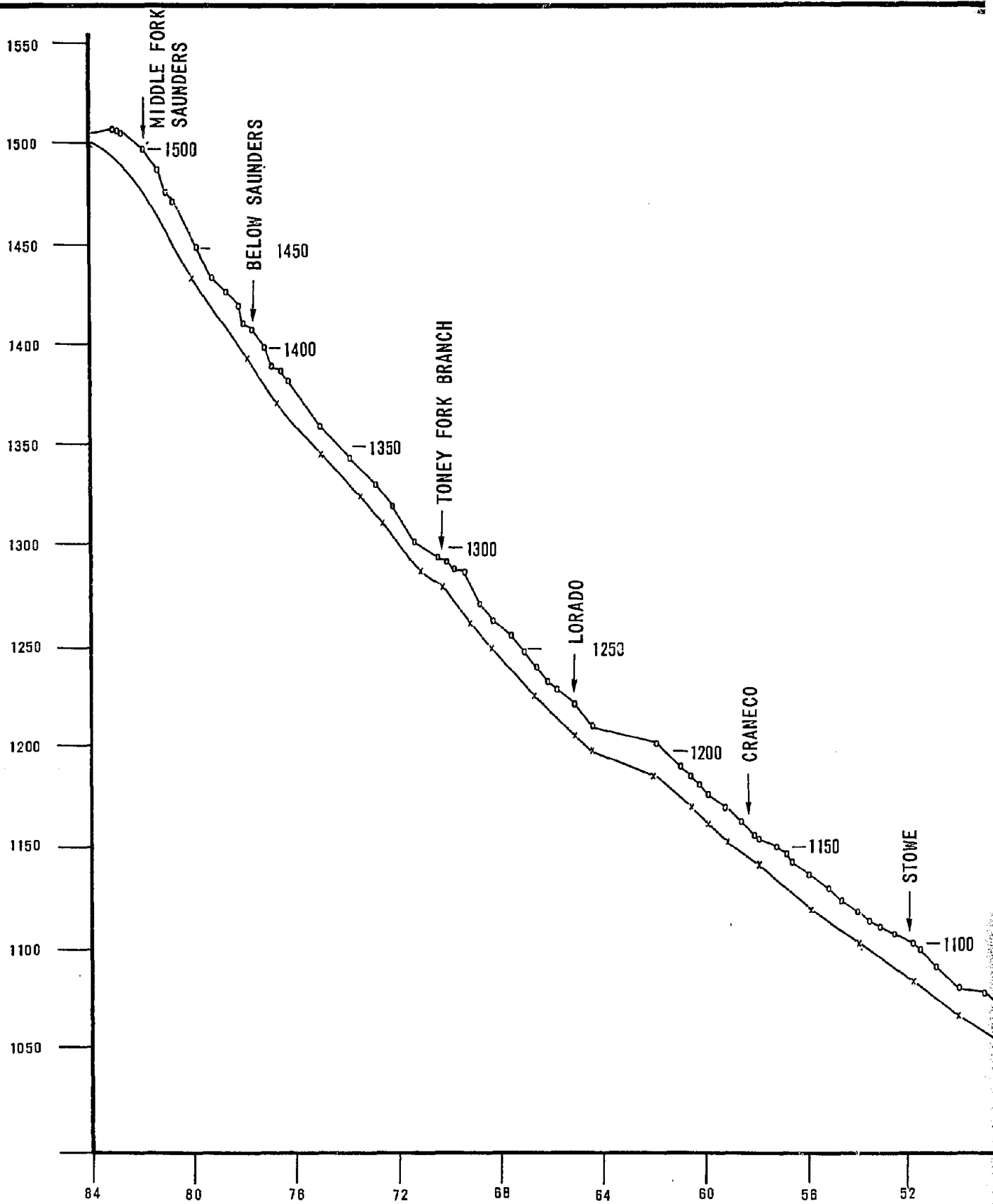

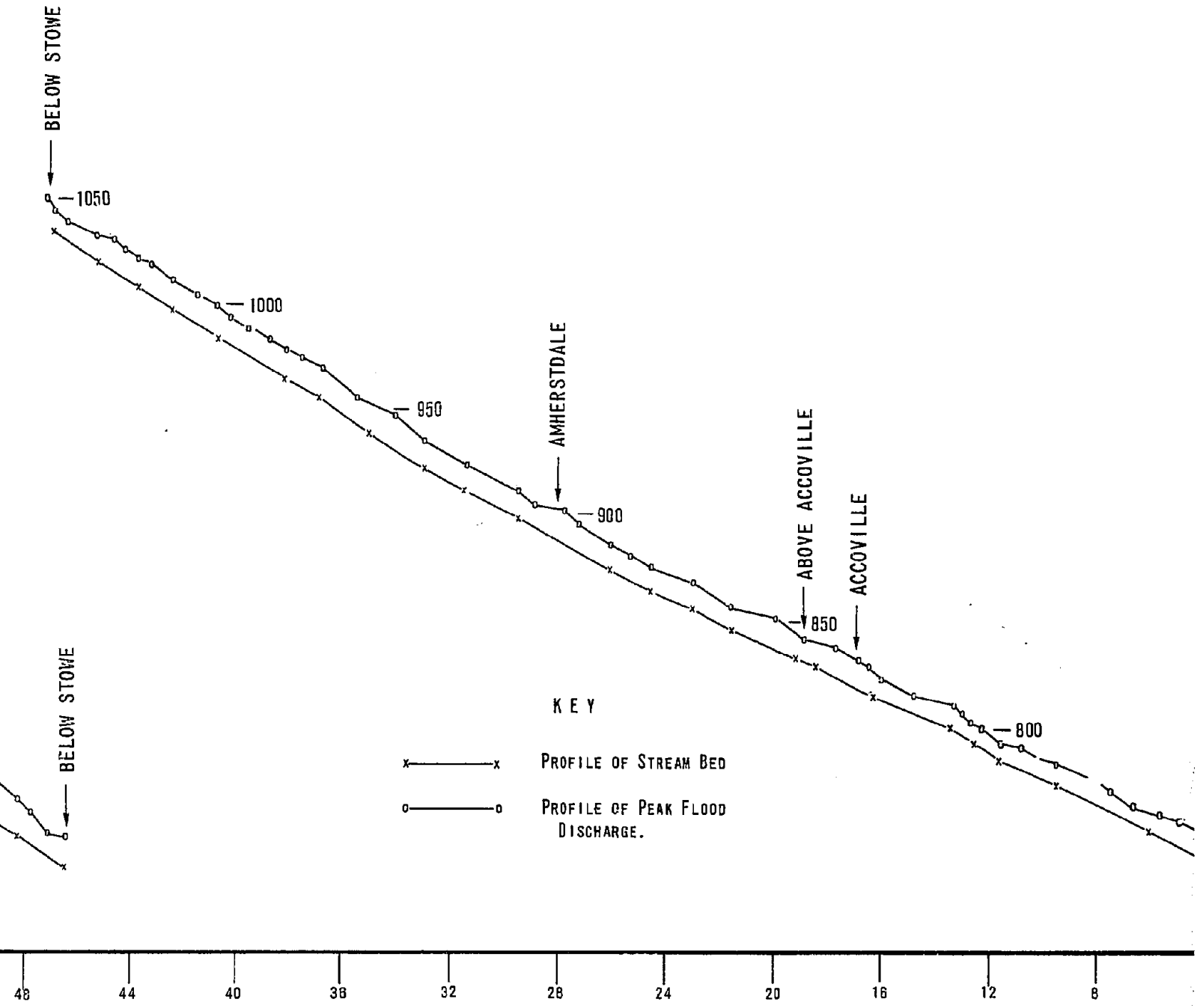

K E Y

x — x PROFILE OF STREAM BED

o — o PROFILE OF PEAK FLOOD DISCHARGE.

DISTANCE, IN THOUSANDS OF FEET

W.A. WAHLER & ASSOCIATES	COAL REFUSE DAM FAILURE SAUNDERS, WEST VIRGINIA
PALO ALTO • NEWPORT BEACH • CALIF.	

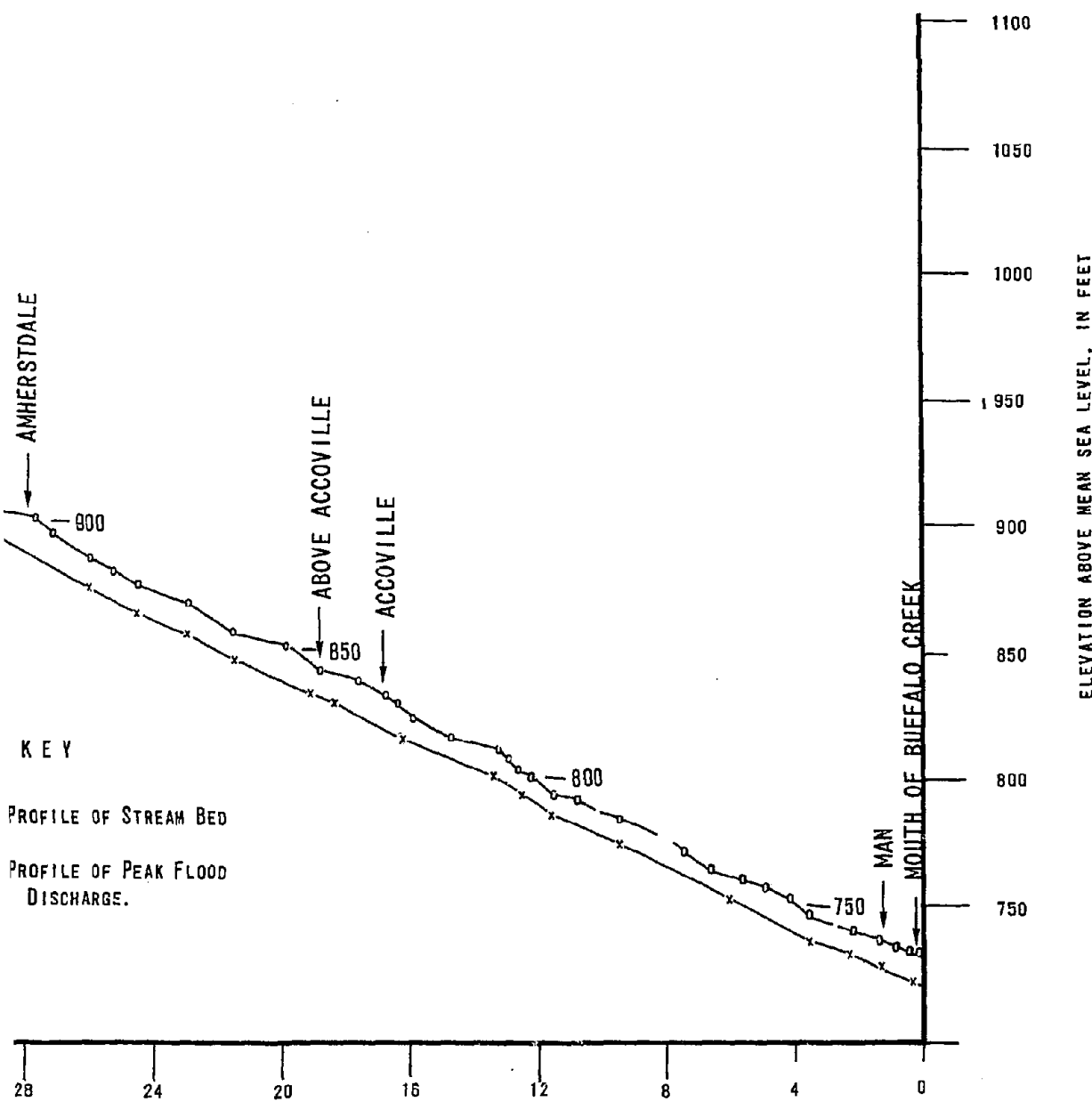

KEY

PROFILE OF STREAM BED

PROFILE OF PEAK FLOOD DISCHARGE.

W.A. WAHLER & ASSOCIATES	COAL REFUSE DAM FAILURE SAUNDERS, WEST VIRGINIA	PEAK FLOOD DISCHARGE		
		PROJECT NO. 0700	DATE NOVEMBER 1972	FIGURE NO. VIII-3

PALO ALTO • NEWPORT BEACH • CALIF.

Although the immediate area where the Middle Fork Valley joins the Buffalo Creek Valley showed a great degree of scour (particularly on the right side of Buffalo Creek Valley toward which the flood waters were directed by the burning waste dump), there was little other evidence of scour other than at some railroad and highway bridge abutments downstream. This was probably due to the depth of the water flow, and the significant restrictions on velocity created by debris dams which intermittently formed and then failed as the flood progressed downstream.

The amounts and distribution of materials disturbed by, or involved in, the failure and flood in Middle Fork Valley were estimated during our analyses. The quantities and locations of the materials involved support the most probable mode of failure of Dam No. 3 discussed in Chapter VII. Because different materials (coarse coal waste and foundation sludge) were mixed together during the failure, it was not possible to perform a rigorous analysis to determine the exact distribution of each material type. However, we believe the assumptions made resulted in a reasonable determination of the distribution of each material type. Basically, the calculation of various quantities involved in the flooding was performed to answer the following questions: (1) how much material was involved in the failure and flood; (2) where did the materials come from; and (3) where did the materials go? The detailed quantities involved in the materials balance are presented in Table VIII-2. The derivation of the data is described in the following discussion.

The results of our calculations indicate that the total volume of material involved in the failure of Dam No. 3 and the subsequent flood in Middle Fork Valley was 548,000 cubic yards. Of this volume, 131,000 cubic yards were sludge and 417,000 cubic yards were embankment materials. Essentially all of the sludge came from beneath the downstream portion of Dam No. 3 and from the Pool 2 area. Of the coarse coal waste,

317,000 cubic yards came from Dam No. 3, about 3,000 cubic yards from Dam No. 2, and 97,000 cubic yards from the refuse bank. The amounts of coarse coal waste from Dam No. 1 sludge from that portion of Pool 1 between Dam No. 1 and Dam No. 2, and sludge from Pool 3 are considered negligible.

The basic distribution of the sludge was as follows: 49,000 cubic yards were deposited in the roiled area, 3,000 cubic yards in Pool 1, and the remaining 79,000 cubic yards was divided between the slide mass (i.e., incorporated into the slides as Dam No. 3 failed) and export from Middle Fork Valley. The basic distribution of the coarse waste was as follows: All of the coarse waste eroded from the refuse bank (97,000 cubic yards) was exported from Middle Fork Valley, and it seems reasonable to assign all of the coarse waste from Dam No. 2 (3,000 cubic yards) to deposition in Pool 1. The remaining available volume of Pool 1, 31,000 cubic yards, was filled with coarse waste from Dam No. 3, leaving 286,000 cubic yards all from Dam No. 3, to be distributed between the slide mass and export from Middle Fork Valley. Since the volume of the slide mass is 245,000 cubic yards, at least 41,000 cubic yards of Dam No. 3 coarse waste must have been exported from Middle Fork Valley. However, the slide mass did include some of the unassigned 79,000 cubic yards of sludge. Our field exploration and gradation test results from the slide mass samples leads us to believe that about 20 percent of the slide mass was sludge and 80 percent of it was coarse waste. Thus, of the 79,000 cubic yards of sludge remaining, 49,000 were probably incorporated into the slide mass and 30,000 were carried out of Middle Fork Valley by the flood. Similarly, of the 286,000 cubic yards of Dam No. 3 embankment materials still undistributed, 196,000 remain in the slide mass near the location of the former downstream toe of Dam No. 3 and 90,000 cubic yards were exported from Middle Fork Valley by the flood. The total amount of material exported from Middle Fork Valley was 217,000 cubic yards, of which about 30,000 cubic yards were sludge and 187,000 cubic yards were coarse coal waste.

TABLE VIII-2
MATERIALS BALANCE
WITHIN
MIDDLE FORK VALLEY

SOURCE OF MATERIAL			DISTRIBUTION OF MATERIAL TO THE INDICATED AREA			
ORIGINAL SOURCE AREA	DISTURBED* VOLUME	TYPE OF MATERIAL	SLIDE MASS**	ROILED AREA	POOL 1	EXPORTED FROM VALLEY
DAM NO. 3	317,000	COARSE WASTE	196,000	----	31,000	90,000
POOL 2 AND DAM NO. 3 FOUNDATION.	131,000	SLUDGE	49,000	49,000	3,000	30,000
DAM NO. 2	3,000	COARSE WASTE	----	----	3,000	----
REFUSE BANK	97,000	COARSE WASTE	----	----	----	97,000
TOTAL VOLUME	548,000	----	245,000	49,000	37,000	217,000

* ALL VOLUMES ARE IN CUBIC YARDS.

** FOR DEFINITION OF SLIDE MASS SEE CHAPTER VI AND FIGURE VI-20.

- NOTES: (1) THESE VOLUMES ARE APPROXIMATE BECAUSE MUCH OF THE DATA WERE DEPENDENT UPON RECONSTRUCTING THE PREFAILURE TOPOGRAPHY.
- (2) VOLUME CHANGES ASSOCIATED WITH EROSION, DEPOSITION, OR SLIDING, DUE TO DIFFERENCES IN UNIT WEIGHTS BETWEEN POINTS OF SOURCE AND DEPOSITION, WERE NOT CONSIDERED.

CHAPTER IX

BIBLIOGRAPHY

- Ad Hoc Commission Report, see West Virginia Ad Hoc Commission of Inquiry into the Buffalo Creek Flood, 1972a.
- Cardwell, D. H., Erwin, R. B., and Woodward, H. P., 1968, Geologic Map of West Virginia, West Virginia Geological and Economic Survey, Morgantown, map: 2 sheets, scale 1:250,000.
- Cedergren, H. R., 1972, Preliminary interpretation of modes of failure of Buffalo Creek Dam, 8 p. Proprietary report to W. A. Wahler and Associates.
- Chisholm, J. L., and Foster, J. B., 1972, Appendix C. Interpretation of eyewitness accounts of Lorado Dam and Buffalo Creek, in Davies, W. E., Bailey, J. F., and Kelly, D. B., 1972, Preliminary evaluation of the engineering geology and hydrology of the Buffalo Creek flood, February 1972, U.S. Geological Survey, preliminary administrative report.
- Citizens' Commission to Investigate the Buffalo Creek Disaster, 1972, Disaster on Buffalo Creek: Charleston, W. Va., 31 p.
- Commission Report, see West Virginia Ad Hoc Commission of Inquiry into the Buffalo Creek Flood, 1972a.
- Davies, W. E., 1966, unpublished file data.
- Davies, W. E., 1967, Geologic hazards of coal refuse banks (abs.): Geological Society of America, Program 1967 Annual Meetings, p. 43.
- Davies, W. E., 1968, Coal waste bank stability: Mining Congress Journal, v. 54, no. 7, p. 19-24.
- Davies, W. E., Bailey, J. F., and Kelley, D. B., 1972a, Preliminary evaluation of the engineering geology and hydrology of the Buffalo Creek flood, February, 1972: U.S. Geological Survey, preliminary administrative report, 56 p.
- Davies, W. E., Bailey, J. F., and Kelly, D. B., 1972b, West Virginia's Buffalo Creek Flood: a study of the hydrology and engineering geology: U.S. Geological Survey, Circular 667, 32 p.
- Davies, W. E., and Gallaher, J., 1966, Results of preliminary examination of coal waste banks in southern West Virginia, U.S. Geological Survey, unpublished file report.

- Harrington, D., and East, J. H., Jr., 1948, Burning refuse dumps at coal mines, U.S. Dept. of the Interior, Bureau of Mines, Information Circular 7439, 28 p.
- Hennen, R. V., Reger, D. B., and Price, W. A., 1914, Logan and Mingo Counties: West Virginia Geological Survey, 776 p. and atlas.
- Kealy, C. D., and Soderberg, R. L., 1969, Design of dams for mill tailings: U.S. Dept. of the Interior, Bureau of Mines, Information Circular 8410, 49 p.
- Latimer, W. J., 1915, Soil survey of Logan and Mingo Counties, West Virginia: U.S. Dept. Agriculture, Bureau of Soils, 30 p.
- Miller, J. W., and Jolley, T. R., 1957, Preparation characteristics of coal from Logan County, W. Va. U.S. Department of the Interior, Bureau of Mines, Report of Investigations 5306, 48 p.
- Myers, James W., Pfeiffer, Joseph J., Murphy, Edwin M., and Griffith, Franklin E., 1966, Ignition and control of burning of coal refuse: U.S. Dept. of the Interior, Bureau of Mines, Report of Investigation 6758, 24 p.
- Park, W. R., Blankenship, J. C., Jr., Cook, J. O., Herndon, J. R., Shumate, J. L., 1972, Interim report of retaining dam failure, No. 5 Preparation Plant, Buffalo Mining Company, Division of the Pittston Company, Saunders, Logan County, West Virginia, February 26, 1972: U.S. Bureau of Mines, Mount Hope, W. Va., 12 p.
- Stahl, R. W., 1964, Survey of burning coal-mine refuse banks: U.S. Dept. of the Interior, Bureau of Mines, Information Circular 8209, 39 p.
- Tavener, W. H., Dowd, J. J., Abernethy, R. F., and Reynolds, D. A., 1956, Estimate of known recoverable reserves of coking coal in Logan County, West Virginia: U.S. Dept. of the Interior Bureau of Mines, Report of Investigation 5259, 50 p.
- U.S. Army, Corps of Engineers, Huntington District, 1972, Flood hazard information, Buffalo Creek, Logan County, West Virginia, Post disaster conditions, (2 vol.).
- U.S. Congress, Subcommittee on Labor of the Committee on Labor and Public Welfare, 1972a, Buffalo Creek (W. Va.) disaster, 1972, Part 1, Dams on The Middle Fork, Buffalo Creek: U.S. 92d Congress, 2d session, 119 p. Prepared by the U.S. Army, Corps of Engineers, Ohio River Division, Huntington District.

U.S. Congress, Subcommittee on Labor of the Committee on Labor and Public Welfare, 1972b, Hearings . . on (The) Buffalo Creek Disaster, Appendices A, B, C, and D: U.S. 92d Congress, 2nd Session, 2 Vol., 2717 p.

U.S. Department of Interior, Task Force to Study Coal Waste Hazards, 1972, Preliminary analysis of the coal refuse dam failure at Saunders, West Virginia, February 26, 1972: Washington, D.C., 42 p.

Walker, F. C., 1972, An examination of the condition which led to the Buffalo Creek disaster in Logan County, West Virginia, February 26, 1972, U.S. Dept. of the Interior, memorandum report, 9 p.

West Virginia Ad Hoc Commission of Inquiry into the Buffalo Creek Flood, 1972a, The Buffalo Creek flood and disaster, Charleston, 2 vol., typescript.

West Virginia Ad Hoc Commission of Inquiry into the Buffalo Creek Flood, 1972b, Hearings Transcript, Charleston, 9 vol.

NOTE: All the above were reviewed during the preparation of this report, but not all were specifically cited in the text. The Hearings Transcript of the West Virginia Ad Hoc Commission of Inquiry into the Buffalo Creek Flood was reviewed only to the extent that it is quoted in various parts of the Commission Report. The copy of the Commission Report which we used was a preliminary typescript loaned to us by the Commission.