

EXAMINING LONGWALL SHIELD FAILURES FROM AN ENGINEERING DESIGN AND OPERATIONAL PERSPECTIVE

By Thomas M. Barczak¹

ABSTRACT

Longwall operators are again pushing the envelope in terms of life expectancy for longwall shields. State-of-the-art shields are now expected to last more than 60,000 loading cycles, twice the life expectancy compared with those of a decade ago. A review of trends in shield design shows that shields continue to increase in both size and capacity. Some state-of-the-art shields now weigh over 30 tons and provide up to 1,200 tons of support capacity. Although life expectancy has increased and modern shields are structurally more reliable, premature failures do still occur. This paper provides an engineering and operational assessment of shield design and provides key points to observe in what causes premature shield failures. Design practices to improve structural margins of safety that will prevent premature failures from occurring are also examined. A survey of recent shield failures is provided, as well as trends in shield design and how they might impact the performance and longevity of a shield. Hydraulic failures are more common than structural failures. Although hydraulic failures occur on all aging longwall shields, they often go undetected for long periods, resulting in degraded support capacity that can lead to serious ground control problems. The fundamentals of shield hydraulics are described in order to evaluate hydraulic failures that plague all shields at some point in their service life, and practical methods to detect hydraulic failures are examined. The paper concludes with recommendations for inspecting damaged shields and safety precautions regarding their continued use.

¹Research physicist, Pittsburgh Research Laboratory, National Institute for Occupational Safety and Health, Pittsburgh, PA.

INTRODUCTION

The decline in the number of longwalls from a high of 118 in 1985 to 62 in 1999 has forced a reduction in the number of shield manufacturers through mergers from 8 to 2. The two major suppliers of shields to the U.S. market are Joy and DBT America (formerly Mine Technik America or MTA). Their share of the market is split fairly evenly: Joy has 32 faces and DBT America has 30 faces [Fiscor 1999]. The author believes that the merger of the shield manufacturers has been beneficial to shield design in two ways. First, the merger has allowed the best of the U.K. shield designs (Joy) and the best of the German designs (DBT America) to be brought forward. By combining the design strengths from each company, the result has been an improvement in both structural design and control system technology. Second, the fierce competition during the decade of the 1980s may have forced manufacturers to "cut corners" relative to design in order to compete for sales, resulting in deficiencies in design that led to premature structural failures and less than adequate control technology. Thus, while competition is generally healthy, resulting in lower prices, there needed to be a better balance of quality and price than existed in the 1980s. The hard reality is that shield manufacturers have to make a profit in order to produce a quality product and to stand behind this product with warranties; this capability was jeopardized in the past and has been improved with the recent mergers.

A survey of the longwall industry was conducted to evaluate problems with current shield technology and future needs. The survey indicates that shields are lasting longer than ever before, but that *premature failures still occasionally occur* and some mistakes from the past continue to be made in recent shield designs. Structural failures tend to be the most catastrophic, often requiring modifications to the original shield design. These failures can cause considerable downtime and loss of production, and expose the mine workers who must change out the damaged components to increased risk of injury. Hydraulic failures are common to all aging supports. These failures often go undetected, resulting in degraded support performance that can lead to serious ground control problems. Methods to detect these hydraulic failures are discussed later in this paper.

Due to the maturity of shield technology and the always present economic pressures of the mining industry, longwall operators are now keeping shields in service longer than ever before. In addition, due to the increases in longwall productivity, the number of operating cycles per year continues to increase. The result is that the operators are again pushing the envelope in terms of extending the life expectancy of the supports. *Today's shields are expected to last 60,000-70,000 cycles*; 10 years ago the life expectancy was about 35,000 cycles. Thus, while fatigue failures were not a design issue in the early generation of shield supports, they have become critical to the survival of most longwall operators in an ever increasingly competitive market. Much is being learned about the behavior of aging shields, which are kept in service long enough to fail from fatigue as opposed to failure from poor design or replacement before the end of their useful life due to technological improvements.

Deciding when to retire an aging longwall face and the specifications for a new shield can be a critical decision for any longwall operator. Most mines do not have structural engineers that can actively participate in these decisions. An overview of the fundamental engineering aspects of shield design is provided in the paper, as well as key points that should be considered in the design process to avoid premature structural failures. A primary goal of this paper is to provide mine operators with a better sense of design issues and engineering mechanics that are relevant to shield design. *The intent is not necessarily to have the operators learn enough to know all the answers, but to provide them with enough insight so they know what questions to ask* and what to look for relative to failures that may occur. These insights into shield design should also be beneficial to the Mine Safety and Health Administration in evaluating the safety of longwall shields.

The paper concludes with some practical recommendations regarding what to look for and actions to take when failures do occur. These key points will help mine operators examine failures and provide responsible actions to ensure the safety of the mine workers when shield performance is degraded.

RECENT TRENDS IN SHIELD DESIGN

The basic shield structure has remained unchanged for the past 20 years (figure 1), although the structures have grown dramatically in size and capacity. There have also been technological improvements in electrohydraulic control systems that have dramatically impacted the operation of the support. Consequences of these changes in shield design are discussed below.

MATERIAL SPECIFICATIONS

The German shield companies (currently conglomerated under DBT) have in recent years promoted the use of high-strength steels (>100,000-psi yield) to minimize component cross-sectional dimensions. This trend continues in the present

with both DBT and Joy Technologies. High-strength steel applications were first used in canopy structures to minimize the cross-sectional thickness of the canopy in low- to moderate-seam applications. Today, high-strength steel in all shield designs are necessary to provide the required strength for various shield components in high-capacity designs. Although the added strength has helped to extend shield life, the high-strength fabrications are more susceptible to brittle failure and catastrophic fatigue failures. Another consequence of some high-strength steel applications is that special welding practices are required (heat control, etc.), which makes underground repairs more difficult.

CAPACITY

Support capacity has continued to increase throughout the history of longwall mining. This trend for the past 15 years is shown in figure 2 [Fiscor 1999]. Average support capacities in the United States have increased by nearly 50% since 1985 to an average support capacity at yield of 768 tons for the 62 operating longwalls in the United States in 1999. Twelve installations (19%) of the current longwalls employ shields with capacities greater than 900 tons, and 19 installations (50%) have capacities between 700 and 900 tons. The current distribution of shield capacities is shown in figure 3. The highest capacity shield used in the United States is 1,170 tons [Fiscor 1999]. As shown in figure 2, maximum shield capacities have evolved from 800-ton shields, which were common from 1985 to 1990, to 1,200-ton shields in 1999.

The increase in capacity has significantly impacted shield design and ground control capability. In order to provide the increased support capacity, larger diameter leg cylinders had to be utilized. One consequence of the larger diameter leg cylinders has been a proportional increase in shield stiffness. This increase means that the load developed in the support structure will occur at less displacement or face convergence. Although the increased stiffness may provide superior control of the immediate roof, main roof weighting that causes irresistible (in terms of the shield capacity) convergence on the longwall face will result in greater shield loading with the stiffer shield design. As a result, it is not uncommon for the high-capacity shields to be fully loaded to yield capacity just as often as the lower capacity designs that they replaced. An example is illustrated in figure 4, where a 500-ton, 800-ton, and 1,000-ton shield are all fully loaded when 0.5 in of convergence occurs.

Another consequence of the larger diameter leg cylinders is that the leg socket must be designed to accept greater loads. Historically, the leg socket has been a source for premature shield failures, and the increased loading makes the design even more demanding. In addition, the larger diameter leg cylinders require a wider and longer socket, which places further demands on the design of the socket and load transfer to the base and canopy structures. In general, the larger diameter

cylinders have resulted in wider support components, which are more susceptible to torsion loading than before.

Several models have been developed over the years to determine support capacity requirements. While these concepts attempt to capture the support and strata interaction principles, state-of-the-art shield capacities cannot be justified based on these concepts. A "bigger is better" attitude has prevailed, which has been promoted by the manufacturers largely because of the demands of mine operators to improve the life expectancy of the shields. Thus, it is the life expectancy issue, along with ground control requirements, that have controlled recent developments in longwall shield design and capacity determinations.

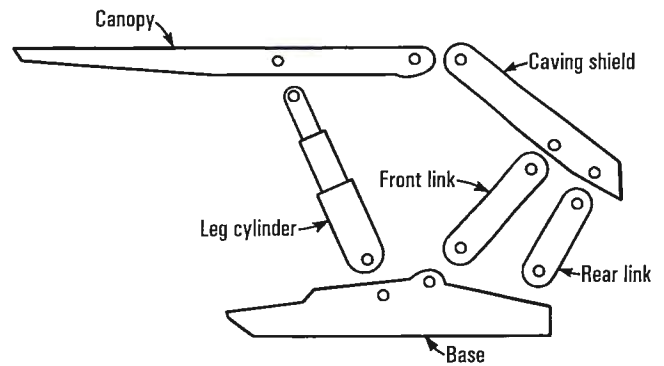

Figure 1.—Diagram of shield components .

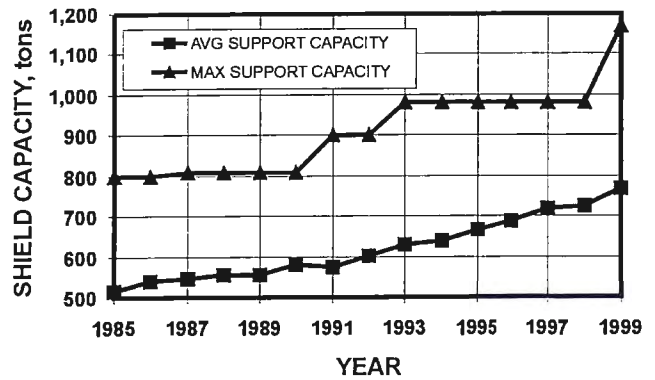

Figure 2.—Trend showing increase in support capacity.

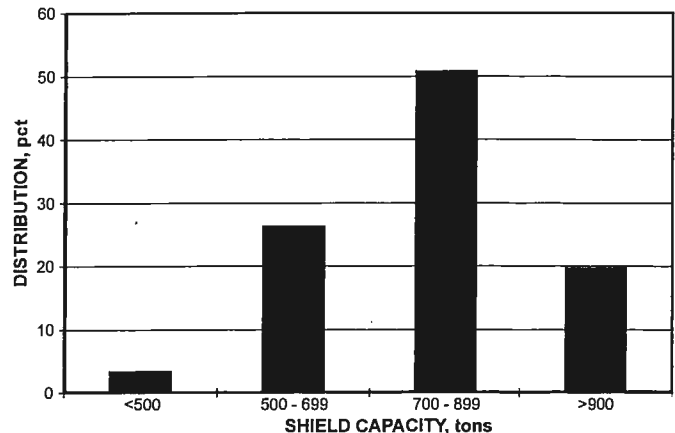

Figure 3.—Distribution of capacity for shields operating in 1999.

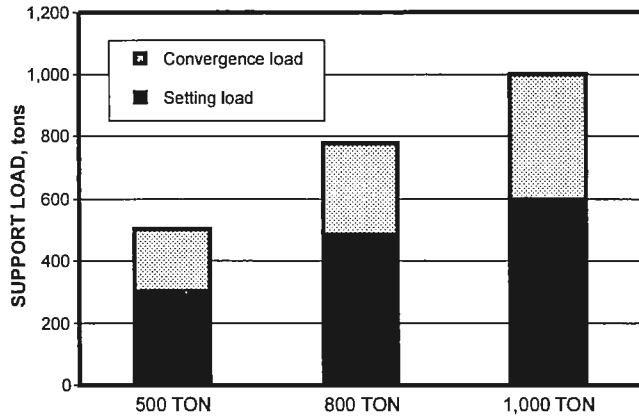

Figure 4.—Setting load and load developed due to 0.5 in of roof movement for shields of various capacities.

SHIELD TYPE

There has been a steady increase in the use of two-leg shields in favor of four-leg shields during the past decade, and two-leg shields are becoming the favored support worldwide. In 1997, 63 of the 65 longwall faces in the United States were two-leg shield systems, compared to only 53% in 1985. Larger size hydraulic cylinders have been developed in recent years to accommodate the increased demands for higher shield capacities and have allowed these capacities to be realized with two-leg designs that were not possible 10 years ago.

There are several consequences of the two-leg design. From a support strata interaction perspective, the two-leg shield provides an active horizontal force toward the coal face due to inclination of the leg cylinders. This active horizontal force improves overall strata stability by arresting slippage along fracture planes or by preventing the expansion of highly jointed or friable immediate roof geologies, which may be further damaged by the front abutment loading. In terms of the shield loading, this increase in active horizontal loading also translates into proportionally higher lemniscate link loading. Historically, lemniscate link pins and wear in bores have been a primary cause of premature shield retirement and/or rebuild. Thus, pin diameters and bore areas need to be increased in higher capacity shields to prevent this problem from becoming more prevalent.

Another issue related to the two-leg concept is higher contact pressure on the canopy and base. High toe loading, caused by the moment created by the line of action of the resultant vertical forces acting on the canopy and base, can be a problem in high-capacity two-leg shields and should be considered in the support design. Base toe pressures of ≥ 600 psi can be expected on high-capacity two-leg shields. Base toe lifting devices are now standard on most two-leg shields to assist in the advancement of the shields, particularly in soft floor conditions. There has also been a trend toward solid base designs to reduce floor-bearing pressures in two-leg shields.

SIZE

In addition to wider shields required by larger diameter leg cylinders, there is a trend toward wider shields to minimize hydraulic cylinder maintenance and reduce the total cost by employing fewer leg cylinders on a longwall face. Again the issue of torsion (twisting of canopy and base) is important in designing wider shields. It is not as easy as simply extending the width of the canopy and base. These components also need to be strengthened for torsional loading. Additionally, there is the issue of weight. The 2-m-wide designs may represent an upper limit with current shield construction materials. If high-capacity designs are to prevail, then lighter weight materials such as composites are likely to be needed to develop widths much beyond 2 m. The application of composite materials to longwall shields is an area that has not yet been explored and will require a whole new set of engineering requirements to implement into shield design. Although these materials offer significant strength-to-weight ratio advantages, there are problems regarding abrasion, pin-bearing areas where components rotate relative to one another, torsion and shear stress control, and costs.

In addition to increases in width, shields have increased in length to accommodate one-web-back operations, larger face conveyors, and deeper shearer webs. Longer canopies and bases create much larger bending moments that require stiffer and stronger components than in previous generation supports. The increase in length is largely responsible for the need for greater shield capacity as the area of roof loading carried by the shield increases or the greater convergence is seen by the cantilevering of the immediate roof beam as the resultant shield force moves further from the coal face.

SETTING FORCES

Setting forces have increased in proportion to the increase in yield capacity because the size (diameter) of the leg cylinders has increased to accommodate the higher yield capacities, while the hydraulic setting pressures have remained constant in the 4,000- to 4,200-psi range. This design practice, coupled with the increased stiffness of the higher capacity supports, means that the higher capacity shields are fully loaded as often as their lower capacity predecessors (figure 4).

HYDRAULIC COMPONENTS AND CONTROL SYSTEMS

Both Joy and DBT continue to make improvements in the electrohydraulic control systems, making them more reliable, more user-friendly, and easier to diagnose when problems occur. A description of these systems can be found in Barczak et al. [1998]. Solenoid-operated valving systems are now

becoming standard. Spool valves have been shown to be superior to ball-and-seat designs, which are prone to contamination problems. In addition, these systems allow the solenoid to be activated upon demand, unlike previous systems that required the hydraulic feed to be interrupted by a control solenoid. This leads to both quicker and smoother control of support functions.

HYDRAULIC EMULSIONS

For many years, longwall shields have utilized a water/mineral oil emulsion as a hydraulic medium for the leg cylinders. The standard system has been a 5% oil/water emulsion. There is a trend toward the use of synthetic fluids. Most western mines have now switched to "low-treatment" systems with synthetic oils in concentrations of only 1% to 2%. This has largely been due to environmental issues imposed by the Utah Department of Natural Resources. Only one eastern mine

is currently using the low-treatment emulsion system. Fazos, Inc., (Australia) has experimented with an all-water system.

Although the synthetic oils are environmentally preferred, they cost significantly more. The synthetic concentrate is about three to five times the cost of mineral oils. Thus, despite the lower concentration used in the low-treatment systems where less than 2% oil is utilized, the overall cost is typically about 50% greater than high-treatment systems using 4% to 5% mineral oil concentrations. The major disadvantages of the synthetic low-treatment system is that there is little room for error. A small drop in the oil concentration can lead to lubrication and acidity problems. Therefore, maintenance of the oil/emulsion is much more critical than in the high-treatment systems, where the oil content can be reduced from 5% to 4% with little, if any, detrimental effects. Bacteria growth can also be accelerated in very low concentrations of oil emulsions, which can cause more severe corrosion problems than if there were no oil at all.

SUMMARY OF SHIELD FAILURES EXPERIENCED BY MINE OPERATORS

There have been numerous shield failures throughout the history of the shield support. A summary of these is provided below. Although failures have declined, particularly premature failures that occur early in the shield life, there are still isolated cases of premature failures. Shields have a finite life, and fatigue failures will eventually occur on all shields if left in service long enough.

HISTORICAL OVERVIEW OF SHIELD FAILURES

Base Failures

Base failures seem to be the most prevalent and usually occur from fatigue after the support has been in operation for several panels of extraction. A common failure mechanism is when the leg socket casting breaks away from the base structure. Formation of this failure is difficult to detect while the support is in service, as the leg socket is housed deep inside the base structure and this area usually is full of debris. Once the leg socket breaks loose, the support quickly becomes inoperable. The bottom plates of the base have insufficient strength to withstand the leg forces, and the leg cylinder will literally rip the base apart by tearing off the bottom plate.

Failure of the base structure (plates) can also occur without the leg sockets failing. The probable failure mechanism is bending of the base. This is more likely to occur in mine sites that have very strong immediate floor strata. In these hard floor conditions, steps in the floor may be left by the shearer, as it is difficult to maintain a constant height of extraction from cut to cut. The base structure is then simply supported in two locations and is flexed as loading is applied. Repeated flexure

causes the base to deform (plastically) or promotes fracture from fatigue, which eventually results in failure of the base structure. In softer floor conditions, the strata deform to provide a fuller contact to the base. This alleviates much of the bending and reduces the risk of failure. Standing the support on the toe of the base can also result in damage of the base structure. This configuration causes maximum stresses in the toe region, and the base will deform or fail usually where the cross section is a minimum in the section of the base forward of the leg connection.

Internally, the base structure is constructed with stiffeners that hold the top and bottom plates apart to form a beam arrangement, which gives the base its bending strength. Cases have been reported where these stiffeners have not been properly welded in place or where the dimensional tolerances were not within specifications. In these cases, the stiffeners broke loose and the base structures literally collapsed. This problem seems to be largely a matter of quality control, but it is critical to support safety. Since the stiffeners are hidden inside the base structure, it is virtually impossible (excluding x-ray inspection) to see these deficiencies prior to the failure.

Canopy Failures

Canopy structures are constructed of stiffened (top and bottom) plates similar to base structures, and thus they are susceptible to bending-induced failures as well. Structurally, canopies are less stiff than bases, which makes them more susceptible to failure from bending than base structures. However, while permanent deformation of the canopy is a fairly common occurrence, destructions of canopies seem to be less

frequent than observed destructions of bases. This suggests that canopies are less often subjected to critical bending. Three reasons why canopies might avoid critical loading are: (1) immediate roof strata are usually partially fractured, and full contact with the canopy is more easily obtained, which minimizes bending moment; (2) tip loading on the canopy is usually smaller than toe loading on the base since the resultant force is more likely to be located near the toe of the base than the near the tip of the canopy; and (3) the canopy surface area is larger than the base area, which allows the canopy to distribute load more efficiently.

Another common deformation of the canopy is "wrinkling" of the top plate between the internal stiffeners. This is due probably to concentrated loading at locations between the stiffeners, but might also be an indication of failure of the weldments that hold the stiffeners in place. If the stiffeners are not secure, the plate may buckle from excessive stress that results in bending of the plate between the more rigid stiffeners.

Caving Shield And Links

Link members have become considerably more robust in shield designs over the past 10 years, and failures have been substantially reduced. Since the caving shield-link assembly has very little vertical load capacity (stiffness), links are not highly stressed for most load conditions. Almost all link failures can be attributed to conditions or operating practices that promote standing the support on the toe of the base or conditions that cause large horizontal displacement of the canopy relative to the base.

Failure of the structure is most likely to occur in the region near the (pin) hole located on each end of the member. The failure mechanism is most likely crack formation somewhere on the circumference of the hole from localized high stress development. The pinholes elongate from continued wear and contact with the higher strength link pins. This results in point loading of the pins and high stress development at the contact areas. These failures are difficult to detect since this area is obscured from view by the caving shield clevises or base structures. Although link failures are rare, they can be catastrophic, as the links provide horizontal stability to the support structure.

Likewise, caving shield failures are fairly rare, but are more likely to occur than link failures. While links are designed primarily for axial loading only, shield mechanics indicate the primary loading mechanism for the caving shield is bending and torsion. Maximum stresses and failure are most likely to occur in the clevis areas, where pins connect the link members to the caving shield. Some general yielding by bending deformation of the caving shield structure may also occur.

Leg Cylinders

Assuming that the face area is sufficiently stable to prevent bumps (violent outbursts of energy), it is unlikely that leg

cylinders will experience structural failure since they are designed to control loading by hydraulically yielding at specified pressures. The most common failure associated with leg cylinders is seal leakage. Internal leakage may occur through other sources, which will be discussed later in this paper.

Another potential failure mechanism for hydraulic leg cylinders is malfunction of the yield valves, which allows leg pressure to increase beyond design levels. Usually, the excessive pressure will cause seal leakage, so that it is unlikely that sufficient pressure will build up to rupture the cylinder casing. The more common problem is leakage through the yield valve, which causes unplanned pressure losses during normal loading. This leakage can be caused by dirt or contamination not allowing the valve to seat properly or worn seats, defective springs that maintain the valve in the closed position, or the fitting itself may leak due to bad O-rings or seals.

FAILURE ASSESSMENT OF SHIELDS CURRENTLY IN SERVICE

Based on an informal survey at longwall mines, the age distribution of the shields operating in 1999 is shown in figure 5. The range of operating life extends from 0 to 14 years of service. An average shield operates about 4,000 cycles per year; this translates into a face production of approximately 2.5 million tons per year. Thus, an average 10-year-old shield would have 40,000 loading cycles, whereas a shield employed on a high-production longwall (4 million tons per year) would have about 65,000 loading cycles. Approximately one-third of the shields have been in operation from 4 to 6 years (16,000-24,000 cycles), and slightly more than one-third (37%) have been operating for more than 6 years (24,000 loading cycles).

Figure 6 shows a near-linear increase in structural failures with age. Failure is defined as structural damage to any support component. It does not necessarily mean catastrophic failure that renders the support inoperable. The linear relationship suggests that *more than just fatigue failures are occurring*, since

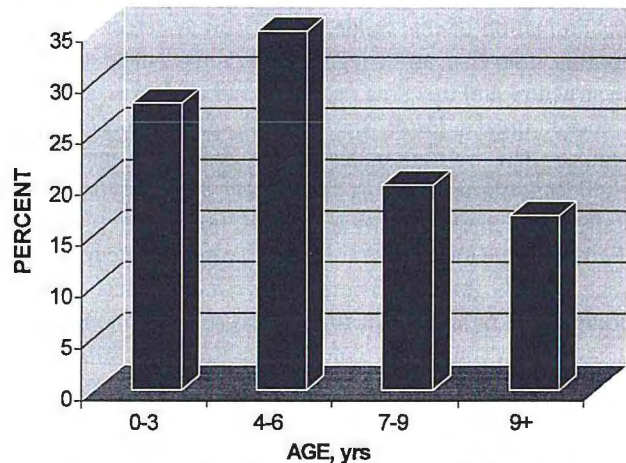

Figure 5.—Age distribution of shields operating in 1999.

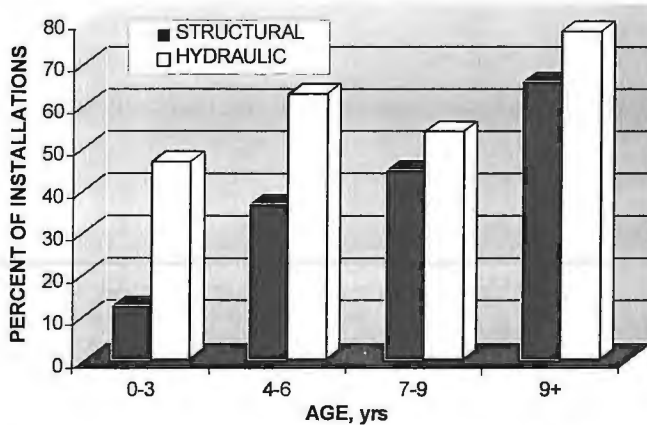

Figure 6.—Distribution of structural and hydraulic failures on shields as a function of age.

the frequency of fatigue failures should increase at a much greater rate as the shield ages. There were a wide range of structural failures reported. Most of the major failures involved either the leg sockets or pin joint problems (i.e., lemniscate link pins and clevises). These two failures are most likely to put a shield out of service and/or require structural modification to keep the support in service. Other structural failures occurred at areas of high stress concentration, including the side shield on the canopy structure, the canopy capsule tilt cylinder bracket, the base bridge, the link cutout areas in the caving shield, various mounting brackets including the pilot-operated/yield valve manifold, and dishing of canopy skin covering plate. There were a few isolated cases of leg cylinder casing problems, but no catastrophic failures.

There were *more hydraulic problems reported than structural problems* (figure 6), particularly in shields that have been in operation less than 6 years. There were nearly four times the number of hydraulic failures in shields operating 3 years or less and nearly twice as many for shields in the 4- to 6-year range than there were structural failures for the same age group. Obviously, the weak link in shield design is the hydraulic system. Numerous hydraulic failures or problems were reported. The high frequency of failures in the first 3 years of operation is distorted by failure of a component called a hydrafuse. The hydrafuse is a safety device incorporated by Joy as part of the leg cylinder design on its recent generation of shield supports in response to a fatality that occurred recently in Australia. An Australian mine worker was killed when the hydraulic fluid in the retract annulus of the leg cylinders was inadvertently pressurized while setting the support. Normally, the retract port is open through the return line back to the hydraulic reservoir whenever the leg cylinder is being pressurized. This is necessary since the pressure would be highly intensified (by a factor 30 or more) if the port was blocked, as in the case of the Australian fatality. The resultant pressure intensification caused the cylinder end cap to rupture, striking and causing a fatal injury to the mine worker.

The hydrafuse is incorporated into the retract circuit and acts as a yield valve to prevent the inadvertent buildup of pressure in the retract annulus of the leg cylinder. The design utilized by

Joy features a brass clip that shears off at a predetermined load (hydraulic pressure). Once the clip is broken, the "fuse" must be replaced. With a failure pressure of nearly twice the pump operating pressure, it was expected that the fuse would provide the desired safety on the rare occasions when there was abnormal pressure and that replacement of the hydrafuse after the failure would not be an inconvenience. Surprisingly, hydrafuse failures began occurring on several shields at several mines. The failures seemed to occur whenever the support had set idle for some time and whenever the leg pressure was at or near yield pressure and almost always on the top stage retract circuit. The National Institute for Occupational Safety and Health (NIOSH) conducted a series of tests on a longwall shield under a variety of loading conditions in the Mine Roof Simulator to determine if unexpected pressures were occurring in the retract circuit. None were found. Similar measurements of retract pressure on active shields in underground mines that reported hydrafuse failures were taken by Joy; again, no abnormal pressure spikes were found. However, it is believed that a water-hammer effect is being created by the valve operation. Joy has since installed a restrictor valve in the circuit to dampen out any potential pressure spike. Early indications from the field installations indicate that this may be working to prevent the undesirable failure of the hydrafuses. Unfortunately, the restrictor also increases the time required to lower the top stage. Fortunately, in two-stage leg cylinder designs, the bottom stage is lowered first, and lowering of the top stage is only required when the bottom stage is fully collapsed. Thus, the increased time to lower the top stage will not be a problem during most production mining.

Other cylinder problems caused pressure losses that limited support capacity. One example was due to poor fabrication where the internal bore of the top stage was off center, resulting in a weakened casing that was unable to sustain the pressure intensification that occurred in the top stage. Other problems were reported with defective yield valves that would not reset, resulting in the inability of the shield to adequately hold load after yielding. Similar problems were reported with the staging valve, which also caused loss of pressure in the leg cylinders at a few mines. One mine reported clearance problems with the leg cylinder and the base rib plates where the cylinder leaned into the rib plates, causing internal damage to the cylinder and seal leakage. Failures also occurred with the advance ram cylinders, including failure of shuttle valve springs and structural failure of a hollow tube relay bar design.

Most hydraulic problems are related to internal leakage due to seal wear and/or corrosion of the cylinders. These problems typically begin when shields have been in service 4 to 6 yrs. As figure 6 shows, 60% of the shields had some sort of hydraulic problems during this timeframe. Many problems go undetected for extended periods of time, resulting in degraded support capacity that can contribute to ground control problems in heavy loading conditions. Methods to detect the onset of internal hydraulic leakages are discussed later in this paper. As previously described, there is a trend toward the use of low-

treatment synthetic fluids in western U.S. mines. One western mine reported severe leg cylinder corrosion due to problems with a low-treatment synthetic emulsion on shields that have been in operation less than 3 years.

Problems with the electrohydraulic control systems were also reported. These included sticking solenoid valves (problem

with soaping in emulsion formulation) and chattering valves due to fluid dynamics at high flows. Most mines reported that significant improvements have been made in the latest generation of electrohydraulic controls. In particular, the DBT (MTA) PM-4 system seems to be a significant improvement over the previous PM-3 design.

ENGINEERING ASSESSMENT OF SHIELD DESIGN AND FACTORS THAT CAUSE STRUCTURAL FAILURES

Structural failure can be divided into the following four basic types: (1) general yielding or excessive plastic deformation; (2) buckling or general instability, either elastic or plastic; (3) subcritical crack growth (fatigue, stress-corrosion, or corrosion fatigue), leading to weakening of the component or unstable crack growth; and (4) unstable crack extension, either ductile or brittle, leading to either partial or complete failure of a member. Structural shield failures are generally of types 1 and 3 and occasionally type 4. A better understanding of the cause of these failures can be obtained by reviewing the principles of engineering mechanics for structural design.

BASIC ENGINEERING PRINCIPLES IN SHIELD DESIGN

Classical structural engineering design is based primarily on a strength of materials approach. The goal of this approach is to define the load requirements for the structure and then to proportion the sizes and shapes of the various components to prevent tension failure or to prohibit instabilities such as buckling in a compression failure. Failure is prevented by employing safety factors to ensure that the allowable stress in components remain within the elastic range of the strength of the steel. These basic engineering principles are used in current shield design, except *much higher allowable stresses are permitted in shields* compared to the safety factors employed in the conventional design of structures, such as buildings and bridges. Failures by general yielding, such as that shown in figure 7, indicate that shields have been designed without sufficient margins of safety to prevent yielding. This is in part due to the low life expectancy of early-generation shield supports. As the demands for greater life expectancy grew, the manufacturers were forced to employ more conservative design approaches. However, even with state-of-the-art shields, it is safe to say that the margins of safety may still remain below that of conventional structural design where life expectancies are much longer and failure of any sort is unacceptable.

Since the longwall face and shield supports are advanced with each shearer cut, the shield is subjected to repetitive loading and the potential for fatigue-related failures. Fatigue is the process of cumulative damage that is caused by repetitive fluctuating loads. Ductile as well as brittle materials are

susceptible to fatigue failures. Since there is no large amount of plastic deformation prior to the fatigue failure, even in ductile materials, *fatigue failures appear with little or no warning*. The failure mechanism is considered to be quite complex, but in general a fatigue crack is initiated at some microscopic or macroscopic stress riser. The crack itself then acts as a stress riser to promote localized yielding in the vicinity of the crack tip. In general, the more severe the stress concentration and the greater the load fluctuation, the shorter the time to initiate a fatigue crack. After a certain number of load fluctuations, the accumulated damage causes propagation of a crack or cracks, leading to failure of the structure.

Conventional structural design for things such as machines and bridges employ relatively conservative design practices relative to fatigue loading to ensure the desired life and safety of the structures. Typically, the fatigue (endurance) limit of conventional steels is about 50% of the tensile (yield) strength. Generally speaking, this means that the nominal load (stress) developed in the shield components must be kept below 50% of the yield strength to prevent fatigue failures from occurring, thereby providing an indefinite life expectancy relative to fatigue failure. Such a design approach for shield supports would require much larger component sizes, which would significantly increase the weight of the shield and, as such, are considered impractical for shield design. As the stress is increased beyond this endurance limit, the number of cycles to failure is reduced, starting at about 1 million load cycles. For a life expectancy of 100,000 cycles, which is more representative for longwall shields, the allowable stress to prevent fatigue failure is much closer to the yield strength of the steel, suggesting that a factor of safety of 2 is not needed in shield design, at least in relation to fatigue issues. Of course, these generalities are subject to the specific properties of the steel and the support construction. The allowable stress may be considerably less in some circumstances. For example, the allowable stress to prevent fatigue failure for a plate welded on the flange of an I-beam (similar to a plate welded on the bottom of the base pontoon) is only 15 ksi [American Institute of Steel Construction 1980].

In addition to fatigue, stress corrosion causes failures to occur under *statically* applied loads with stress developments well below the yield strength of the material and independent of the number of load cycles. This can account for structural

failures that occur at low-production mines with aging shields where the number of cycles is low, but the age is high. In other words, a shield does not necessarily have to have many cycles to fail. The failure occurs due to crack initiation caused by the corrosion and subsequent propagation of this crack or material defects similar to those observed for fatigue loading. The author believes that *stress corrosion is a significant and the most overlooked factor in current shield design*. The mine environment is often wet and acidic, which accelerates corrosion of shield components, as shown in figure 8. The base units in particular are subjected to extensive corrosion since the wet debris continually forms around and often covers much of the base structure. An area of particular concern is the leg socket, which collects rock and coal debris throughout much of the shield's operating life. When combined with fatigue loading (corrosion-fatigue), stress corrosion causes a further reduction in the useful life of the longwall shield. Corrosion-fatigue damage occurs *more rapidly* than would be expected from the individual effects or from the algebraic sum of the individual effects of fatigue, corrosion, or stress-corrosion cracking.

The science of fracture mechanics was developed during 1946-66 to analyze unexplained failures in several large-scale complex structures where brittle fractures were observed at stress levels no larger than were expected when the structure was designed [Barsom and Rolfe 1987]. The underlying premise in fracture mechanics is that real structures contain numerous discontinuities of some kind. These discontinuities can be flaws in weldments, poor fabrication practices where torch cutting leaves surface scars and abrasions, or cracks in base or weld materials due to factors like corrosion. These discontinuities act as stress risers, and unstable, rapid fracturing occurs when the stress intensity factor at the crack tip reaches a critical value. Such discontinuities certainly exist in longwall shields and are undoubtedly a *primary source of structural failures*.

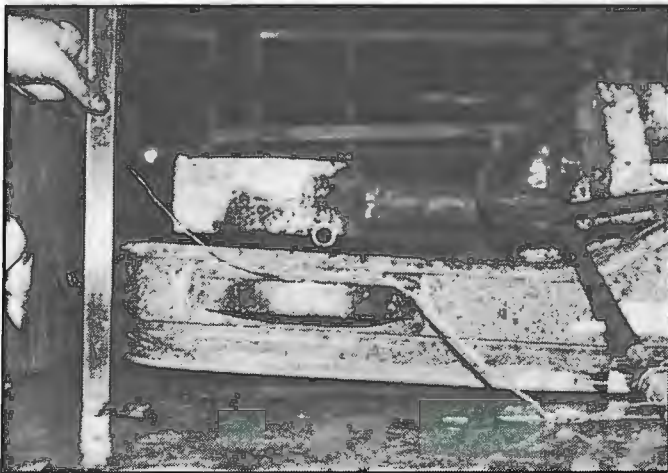

Figure 7.—General yielding of toe of base unit in shield design from early 1980s.

The goal in fracture mechanics design is to keep the stress intensity level below the critical value that promotes crack propagation (figure 9), much like the goal of strength of materials design is to keep the design stress within the material's elastic range. To ensure that a structure does not fail by fracture, the number of cycles to grow a small (often microscopic) crack to a critical crack length must be greater than the life of the structure. Thus, the key idea to consider in a fracture mechanics design is the ability of the steel to absorb strain energy. If the material has a high absorption capability, such as mild steel, crack growth will be limited to plastic flow of the material, and general yielding will typically prevent brittle fractures from occurring. Conversely, the probability of fatigue-related failures increases with low-energy absorption materials. Unfortunately, from a fracture mechanics perspective, state-of-the-art shields are now constructed from high-strength steels (100,000- to 120,000-psi yield strength), which are much *more susceptible to brittle fracture* than the early generation of shield supports, which were constructed from



Figure 8.—Corrosion of a lemniscate link clevis.

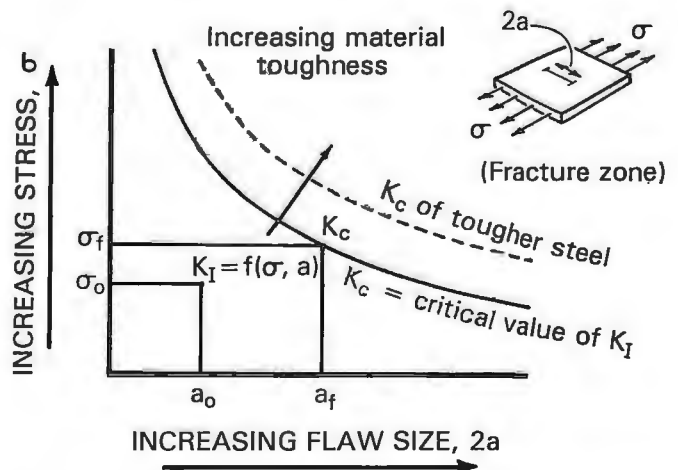

Figure 9.—Fracture mechanics principles regarding material toughness, stress, and flaw size.

mild steel (35,000- to 45,000-psi yield strength). The motivation for the high-strength steel, of course, is to minimize the size of the components and keep the weight of the shield down, which is an ever increasing challenge for the design engineers as the capacity of the shields continue to rise. In essence, the term high-strength steel is a misnomer for two reasons. First, the fracture toughness is reduced, which means that the allowable stress, as a percent of the yield strength, must also be reduced to prevent fracture from occurring. In other words, the full advantage of increased strength of the steel may not be realized. Second, unlike lower strength steels where the weld material is of equivalent or higher strength of the base metal, it is not uncommon for weaker weld materials to be used in the high-strength steel constructions.

DESIGN PRACTICES TO IMPROVE STRUCTURAL MARGINS OF SAFETY AND EXTEND SHIELD LIFE

Since most structural shield failures can be attributed to some form of fracture, the basic elements of fracture control can significantly improve shield life. These are: (1) use a lower design stress, (2) minimize stress concentrations, (3) reduce flaw size or control crack growth, (4) minimize corrosion, and (5) use materials of improved toughness.

Lower Design Stress

Some margin of safety should be employed in the design stress relative to the yield strength of the steel. Civil engineers typically use a factor of 1.66, which means that the allowable stress is about 60% of the yield stress for nonfatigue loading and further reduced by 50% or more when fatigue loading applies. While these levels of safety are not practical in shield design due primarily to cost and weight limitations, it is important to recognize that a small reduction in (tensile) stress developments will significantly reduce crack growth since the two are related by an exponential function. Past practices of designing to or near yield strength should be avoided in modern shield design where the life expectancy exceeds 50,000 loading cycles.

Link pins and clevises are a prime example of historically poor design practices in shield supports, which continue even today. Deformation and/or excessive wear in the pin clevises is undoubtedly the primary cause of premature shield retirement and/or structural rebuild. There are clear indications that these areas are subjected to stress beyond the yield strength of the steel. This poor design is caused partly by manufacturers not giving sufficient credence to the conditions that cause high loading in the caving shield-lemniscate assembly, namely, loss of frictional contact at the roof and floor interface and standing the support on the toe of the base. With the possible exception of shields designed for low-seam heights, there is adequate

space available to increase the bearing area of these clevises and pin diameters to reduce the stress and substantially improve the life expectancy of these components. The joint design problem also needs to recognize the importance of pin tolerance. First, the pin contacts only a portion of the clevis. Typically, arcs of 45° to 60° are used in the design analysis. Obviously, the 45° arc assumption will lead to more conservative designs. Conservative assumptions should be made to allow for reduced areas as wear occurs (figure 10). Excessive pin tolerances can lead to point loading by allowing the pin to rack within the joint clevis, as shown in figure 11. Corrosion effects are also often ignored or not sufficiently accounted for in the design of pins, despite the fact that corrosion is a leading cause of premature pin failures or abnormal wear. Corrosion causes pits to occur in both the pins and clevises (figure 8), which can reduce the bearing area by 25% to 50% and cause a proportional increase in stress.

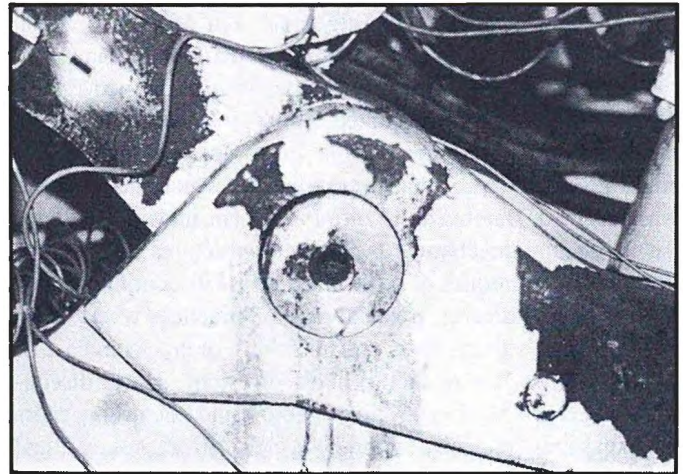

Figure 10.—Reduction in lemniscate pin contact area for worn joint.

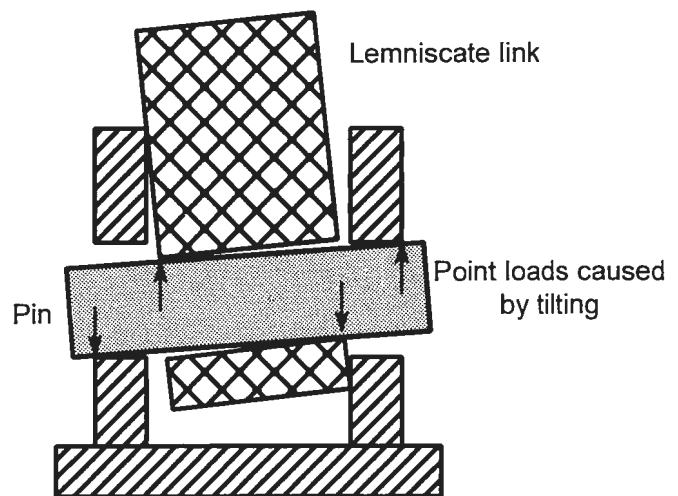

Figure 11.—Racking of pin joint.

Several failures have occurred where the leg socket casting weldments break because of fatigue or stress-corrosion and thereby cause failure of the bottom base plate as the loading is transferred fully to the bottom plate instead of being distributed to the side rib plates. Most of the time, the leg cylinder and casting punch through the bottom plate and into the mine floor, rendering the support inoperable. A common modification to alleviate base leg socket failures of this nature is to add another plate to the underside of the base pontoon, as shown in figure 12. Typically, this plate is about 1 in thick and usually covers most of the length of the base pontoon. Reinforcement is also typically added to the top area of the side base plate. While this plate stiffens the side plate, its primary purpose is to restore the location of the centroidal axis, which was changed by the addition of the bottom plate, to its location in the original base design. Because of past failures of this nature, support manufacturers are now beginning to incorporate a thicker bottom plate in the initial shield design.

Some mines have successfully reduced operating stress levels by *derating the shield support* before underground installation. The derating is accomplished by installing yield valves with a lower operating pressure than specified in the design. Since the leg capacity controls the maximum load developments within the support, lower leg loads translate into reduced component loading. For example, if a 1,000-ton shield support is derated by 10% to a 900-ton capacity, the margin of safety relative to the tolerable crack size that will prevent fatigue fracture may increase by 20% to 30%.

Minimizing Stress Concentrations

There are numerous sources of stress concentrations in longwall shield supports. The most common is a change in geometry. These stress concentrations should be identified and their magnitudes quantified during the design and performance testing phase. One way to do this is to use photoelastic plastics. The photoelastic plastic can be applied to almost any area of the shield structure. Colored fringes will appear on the plastic when observed through a polarized lens that correlate to the stress profiles. *Stress intensity factors of 2 to 3 are not uncommon* for sharp changes in geometry, such as holes or sharp bends in structural members.

One example of a sharp change in geometry is a lemniscate link design with offset pinholes, as shown in figure 13. This link design is typically employed on a shield with a low profile designed for operation in low-coal seams. The bend is necessary to provide clearance with the caving shield in the collapsed or low operating height. Lemniscate links are primarily axially loaded members, but the offset pinhole geometry induces additional stresses due to bending and thereby significantly reduces the margin of safety for this component. Figure 13 depicts failure of a bottom lemniscate link on a 620-ton Westfalia shield that occurred during performance testing at NIOSH's Safety Structures Testing Laboratory. Although the shield had 45,000 load cycles from underground service before

testing, a new link was installed on the shield that was performance tested in the laboratory. This was a new link design that was fabricated for the mine by an outside vendor (not the support manufacturer). Failure occurred after only 14,000 loading cycles. This failure illustrates two problems. First, the design (allowable stress) was too high. Test results revealed that the nominal stress in the link exceeded 90% of the material yield strength. In addition, it appeared that the link side plates had been torch cut, adding an additional stress riser to the already sharp change in geometry at the bend in the link in the area where the failure occurred. These two factors resulted in an unacceptable time to failure. Figure 14 illustrates another problem where the fabrication process left large flaws that led to premature fatigue failure of the base rib. This problem may have been alleviated if the surface had been smoothed to remove most of the surface flaws.

Any hole in a structural plate is another area where stress is concentrated. The structural components of a longwall shield (canopy, caving shield, lemniscate links, and base) are connected by a pin and clevis arrangement. These areas are also sources of stress concentration and fatigue failures on aging longwall shields (figure 15). Another example of a stress concentration caused by a sharp change in geometry is shown in figure 16. Holes are sometimes cut into the canopy or caving shield structure to accommodate the placement of hydraulic hoses. In the example shown in figure 16, failure occurred at the stress riser caused by the sharp corner in a cutout on the caving shield made to accommodate hosing for the side shield. The best solution to this problem is to avoid the hole altogether, and if the hole is necessary, to ensure that the corner radius is as large as possible. Another example of failure due to stress risers created by sharp geometries is shown in figure 17, where a crack developed in the caving shield near the canopy hinge. A clean-out hole is often placed in the side of the base structure to facilitate removal of debris from the leg socket area. This too can be a source for concentration of stress. Since this is a critically loaded area of the base, care should be taken in the design to minimize the stress concentration by incorporating a favorable geometry and orientation with respect to the stress field in this member.

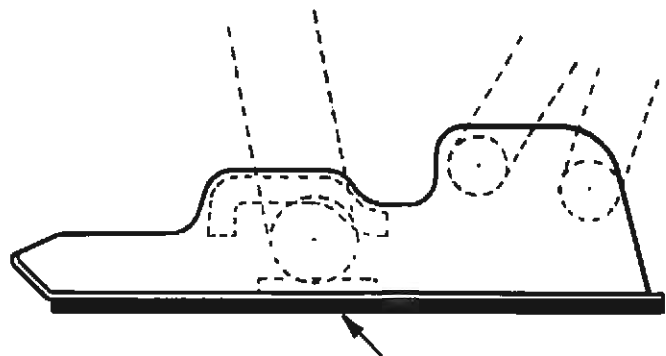

Figure 12.—Modification made to strengthen base in order to prevent leg socket casting failures.



Figure 13.—Failure of bottom lemniscate link.



Figure 14.—Failure of base rib side plate where fabrication process left large flaws.

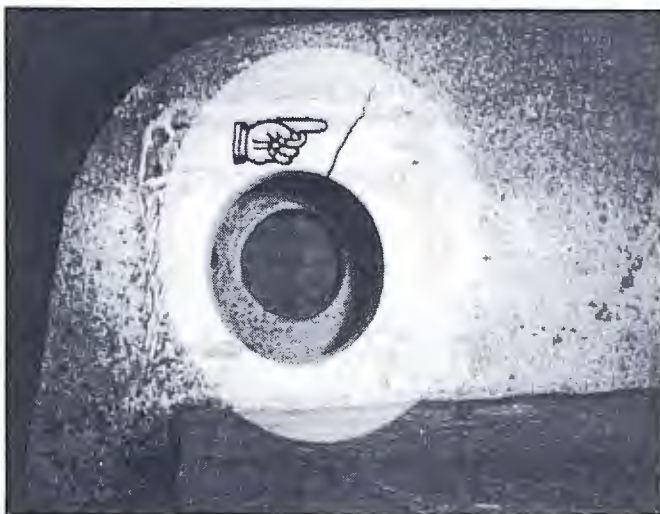

Figure 15.—Failure in base lemniscate link clevis.

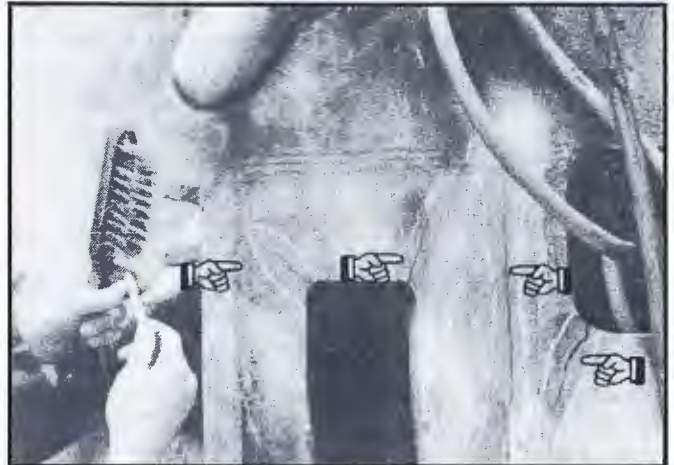

Figure 16.—Failure due to stress concentrations in cutout sections of caving shield.



Figure 17.—Failures of caving shield due to stress concentration in sharp corners where lemniscate links connect.

Figure 18 shows failure of a canopy leg socket casting due to a stress riser created by a sharp change in geometry. The failure in this case occurred in the casting itself. This failure occurred on several shield supports in the late 1980s, all of which used this same basic socket design. Again, this failure probably could have been prevented by a smoother geometry. Leg sockets are often a source of fatigue failures in aging longwall shields. The leg socket is a critical area since the full load developed within the hydraulic leg cylinder must be transferred into the canopy and base structures to be distributed to the mine roof and floor. An examination of the structural mechanics associated with these base socket failures has led to some other design changes that are intended to reduce the stress concentration in the leg socket casting/base structure connection. The rectangular geometry of the socket casting and its placement between the side rib plates of the base structure

position it at right angles to the principal tensile stress caused by the bending of the base structure. This orientation creates a stress intensity factor, which helps to promote fatigue-induced fracturing of the weldment. Some shields are now being designed with an elliptical or zipper-shaped casting (figure 19) so that the front and/or rear edge is not perpendicular to the principal tensile stress, thereby resulting in a reduction of the stress intensity factor.

Reducing Flaw Size or Controlling Crack Growth

Weldments are an essential part of the shield fabrication process. However, since weldments are a primary source of structural flaws, the quality of the welds is critical. As the principles of fracture mechanics illustrate, the initial flaw size created by the welding process is critical to the crack propagation and the margin of safety achieved in this structure. Once a crack develops, it is desirable to keep the crack contained within the weld and not have it progress to the base material adjacent to the weld. This action may depend on the nature of the heat-affected zone in the immediate vicinity of the weld. In general, the heat-affected zone results in anisotropic material properties and residual stresses that tend to reduce the toughness of the steel in this area and increase the likelihood of fracture into the base metal. For the high-strength steels used in modern shield supports, proper heating and cooling of the steel during the weldment process are crucial to preventing crack initiation and growth in the heat-affected zone. This is why it is very difficult to conduct repairs to damaged shields underground, since it is virtually impossible to be able to preheat and properly cool the steel when welding at the longwall face. Another approach that can be used to keep crack growth contained to the weldments is to create breaks in the weldments. This practice is sometimes used in leg socket castings. The break in the weld at the corners of the casting acts like a crack arrester to stop the growth of the crack. This same technique is used in the airplane industry by drilling holes in the metal at the end of an observed crack before it reaches a critical crack length.

Perhaps the best approach to avoid problems associated with weldments is to eliminate them when possible. A good example of this pertains to the leg socket design. A typical construction for the leg cylinder base socket is shown in figure 20. A casting 3-4 in thick and 18-24 in long with a spherical seat to accommodate the bottom of the hydraulic cylinder is placed on top of the bottom cover plate on the base pontoon and is welded in place along the four sides of the top of the casting to the side rib plates and cross plates that connect the two side base plates together. This design is highly dependent on the welds to transfer load into the side rib plates and maintain the structural integrity of the socket connection. An alternative design that is now being used in some canopy leg sockets to alleviate the weld fatigue problem is to cut rectangular holes into the side base rib plates and extend the width of the casting so that it bridges across the cylinder opening, but is supported by the side rib plates (figure 20). In this configuration, leg cylinder loading is transferred directly to the side rib plates of the base structure

entirely through base metal contact and is not dependent on the weldments to achieve this load transfer.

Corrosion Control

Some steps can be taken to circumvent the problems caused by corrosion. The most convenient approach is to try to protect the shield from the environment. For shield supports, this applies mostly to painting with an industrial paint that is resistant to the wet mine environment. However, for some components such as the pins and clevises where there is considerable wear due to the kinematics of the shield during load application, painting or even plating with more resistant material is not an option. Sherardizing pins has proven beneficial, but the effectiveness is limited due to the wear in the joint. Another option worth considering is some form of lubrication for these joints. A simple grease fitting would be an improvement, although somewhat impractical to maintain on an active longwall face. Thus, a sealed joint of some form would be preferable.

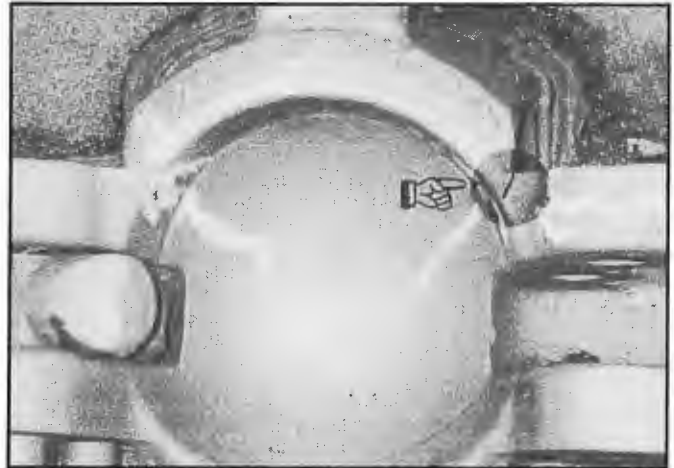

Figure 18.—Failure due to stress riser created by sharp corner in canopy leg socket casting.



Figure 19.—"Zipper-shaped" leg cylinder casting to avoid stress concentration caused by orientation of casting to principal stress field.

Tests have shown that compressive stresses on the surface of materials that are exposed to the environment will not necessarily minimize corrosion-fatigue crack initiation, but they can reduce the possibility of crack growth and thereby prevent failure from occurring. This could be done by induction hardening the joint pins. This, however, might make the pins more brittle.

Material Toughness

The strength of materials approach essentially ignores the toughness of the material, which as described is the most significant material property for fracture control. There is a tradeoff in the use of high-strength steels if they provide superior strength but reduced toughness with greater chance for failure. Since the author is not familiar with the German and U.K. steels used in the shield construction, no specific recommendations are made here, but the issue should be investigated with the shield manufacturer when new shields are purchased.

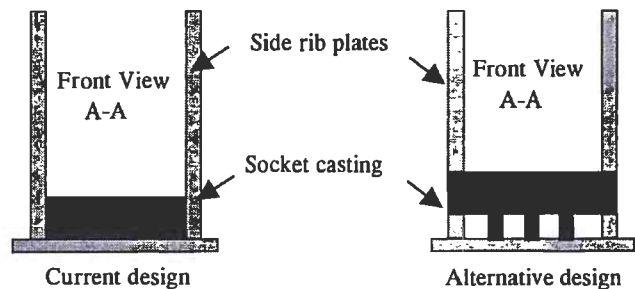
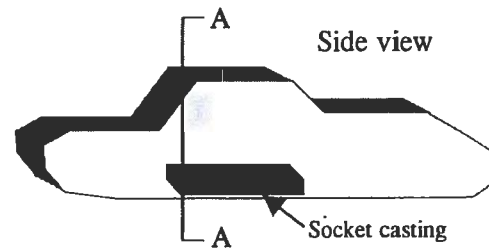

Figure 20.—Conventional and alternative leg cylinder casting design.

KEY POINTS IN EVALUATING HYDRAULIC FAILURES

As described earlier, hydraulic failures are common on aging longwall shields. Although hydraulic failures are generally not as catastrophic as structural failures, they cause a reduction in supporting capability that can lead to serious ground control problems.

FUNDAMENTALS OF SHIELD HYDRAULICS

Hydraulic Cylinder Operation

Since the capacity of a shield is controlled by the hydraulic leg cylinders, a basic understanding of their operation is essential to understanding shield design and causes of hydraulic failures [Barczak and Gearhart 1998]. The basic operation of a hydraulic cylinder can be described as follows (see figure 21). A hydraulic power supply pumps fluid into the cylinder cavity. The fluid acts against a piston, causing the piston and attached steel rod to displace outward. This displacement will continue with very little hydraulic pressure until the support is set against the mine roof and floor. The hydraulic pressure then increases rapidly until the full pump pressure is reached. After the pump supply is turned off or isolated from the support, this pressurized hydraulic fluid is trapped inside the cylinder by a pilot-operated check valve. The pressure of the hydraulic fluid inside the cylinder is then intensified in proportion to any increase in roof loading. A yield valve limits the maximum pressure inside the cylinder to prevent excessive loading that would damage the cylinder. In longwall shields the cylinders are double acting, which means that they are hydraulically powered to both extend and retract (figure 21). Powered

lowering of the support is achieved by pumping fluid inside the retract annulus (figure 21) while at the same time applying pilot pressure to open the check valve to allow fluid from inside the main cylinder cavity that supports the weight of the mine roof to escape back to the hydraulic power supply tank.

The previous example describes the basic operation of a single-stage cylinder, where extension and retraction is provided by one stage. Longwall shields utilize two-stage hydraulic cylinders, as shown in figure 22. Incorporating more stages into a leg cylinder design generally allows for a lower collapsed height, combined with an equal or greater maximum working height to provide operation in a wider range of mining heights.

The basic operating principles of these multistage designs are the same as the single-stage hydraulic cylinder previously described, but there are some noteworthy differences relative to how the individual stages perform:

1. The bottom stage extends and retracts first, followed by the top stage. The bottom stage will extend until it is fully stroked before the top stage will begin to extend.
2. A check valve is installed in the bottom-stage piston (figure 22). This check valve functions to allow hydraulic fluid to flow from the bottom stage to the top stage to cause the top stage to extend during the setting operation whenever the bottom stage is fully extended. It also isolates the bottom stage from the top stage to allow the hydraulic fluid to be intensified in the top stage once the support is actively set against the mine roof and floor. This is necessary to allow the top stage to carry the same load as the bottom stage.

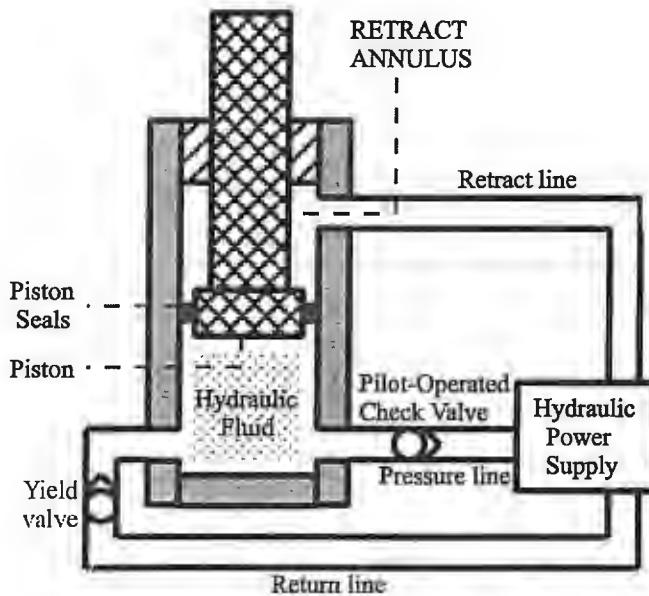

Figure 21.—Functional diagram of hydraulic cylinder operation.

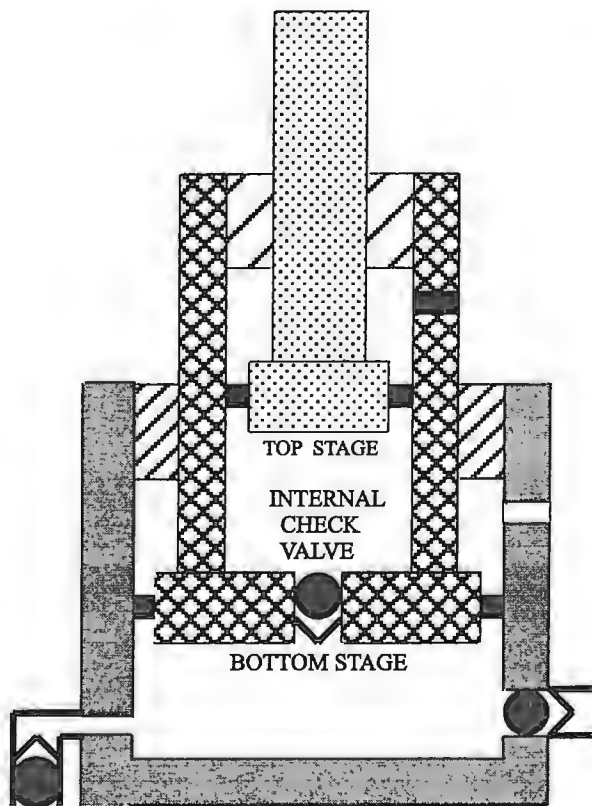

Figure 22.—Two-stage leg cylinder design used in shield supports.

Understanding how the staging functions to provide the necessary support capacity is critical to a proper understanding of multistage leg cylinder operation. For proper operation of the support to occur, force equilibrium must be satisfied for

each stage, which means that each stage must carry the same load. This requires different hydraulic pressures in each stage, since the area of each stage is different. Mathematically, this requirement is expressed by equation 1. If the top stage area is one-half that of the bottom stage area, the pressure in the top stage will be twice that of the hydraulic fluid in the bottom stage.

$$A_1 * P_1 = A_2 * P_2, \quad (1)$$

where A_1 = area of largest diameter (bottom) stage, in²;
 P_1 = pressure in largest diameter (bottom) stage, psi;
 A_2 = area of the top stage, in²; and
 P_2 = pressure in the top stage, psi;

The extension of specific stages at a particular point in time (cycles of operation) depends on the history of the operating heights of the support. When the support is initially raised from a fully collapsed position, the bottom stage will extend first. If the mining height is greater than the stroke of the first stage, the top stage will extend until roof contact is made. On subsequent cycles, the top stage will remain at the initial extension until (1) the mining height is increased beyond that of the initial cycle, or (2) the support is lowered such that the bottom stage is fully collapsed. Assuming that the support is not lowered to the point where the bottom stage is fully collapsed, the top stage will extend beyond the initial extension only when the mining height is increased. In essence, the bottom stage will be fully stroked (1) when the support is initially raised from a collapsed position and (2) on the mining cycle that establishes a new maximum operating height, whenever the support height is higher than it has been on all previous mining cycles. On all other cycles, the bottom-stage extension will reflect changes in mining height relative to the initial mining height and the maximum operating height at which the support was utilized.

An example is used to illustrate these concepts. As shown in figure 23, the initial setting of the support causes the bottom stage to be fully extended 24 in (stroke) and a 12-in (partial) extension of the top stage. If the roof-to-floor mining height is reduced on the second operating cycle by 3 in, the bottom-stage extension now will be 21 in, while the top-stage extension will remain at 12 in. If the mining height is increased by 6 in from that of the second cycle, the bottom stage will again be fully extended (24-in stroke) and the second-stage extension will increase to 15 in on the third cycle. This exercise can continue as shown in figure 23. As shown in this exercise, the top-stage extension on any cycle will equal the initial extension plus the incremental increase in mining height beyond the initial mining height. The top-stage extension will never be less than the initial extension unless the support is lowered to the point where the bottom stage is fully retracted. The bottom-stage extension will fluctuate with changes in mining height on each cycle and will be fully stroked whenever a new maximum operating height is attained.

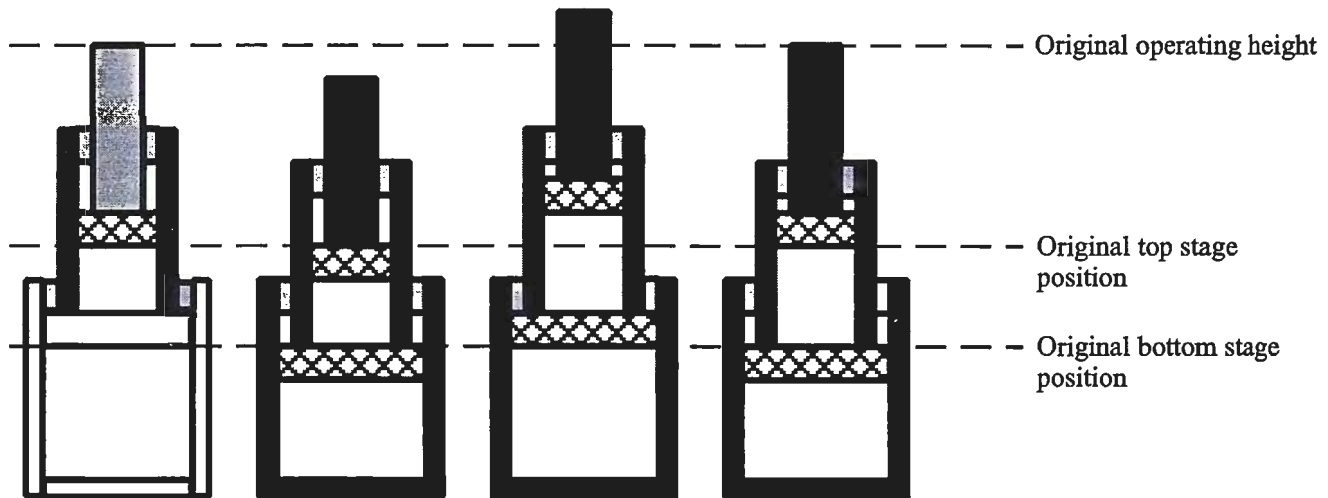

Figure 23.—Example of stage extension for changes in mining height.

Active (Setting) Loads

The shield is actively set against the mine roof and floor by pressurizing the hydraulic cylinders. The force exerted against the mine roof and floor is dependent upon the size of the cylinder and the hydraulic (pump) pressure. In multistage cylinders, the setting force can be determined by measuring the pressure in any stage and multiplying it by the (piston) area of that stage. It is important to remember that the pressure in the top stage is intensified during the setting operation, and only the bottom stage will be at pump pressure once the support is set (assuming that none of the stages are fully stroked). In long-wall shields, the hydraulic pressure is measured only in the bottom stage; thus, the pump pressure times the bottom stage area should be used to calculate the setting force. The total setting force for the support is simply the sum of individual hydraulic cylinder forces.

If the bottom stage is fully stroked, the setting force will be diminished. When the bottom stage that is fully extended no longer transfers all of its force to the mine roof and floor, part of it is consumed by tensioning the cylinder casing as the piston is forced against the mechanical stops that limit its travel. The pressure in the top stage will not be intensified, but instead will be at pump pressure. The setting force will always equal the pump pressure times the area of the largest diameter stage that is not fully extended. Thus, the setting force will equal the pump pressure times the top stage area whenever the bottom stage is fully extended.

The reductions in setting force due to full extension of the bottom stages are typically between 40% and 50% for most shield designs. Thus, a 1,000-ton shield with a setting load of 670 tons at 4,200-psi pump pressure would have a setting force of only 268 to 335 tons when the bottom stage is fully extended. Recalling the operation of the hydraulic cylinder previously described, the setting force will be diminished whenever the bottom stage is fully extended, which occurs on the operational cycle where a new maximum operating height

is attained. The setting force will be restored to its full capability on all other cycles or whenever the support is operated at a height less than the highest operating height on any previous operating cycle.

Yielding Behavior

Yield valves are normally connected to the bottom stage of multistage hydraulic cylinders to provide overload protection. These valves open whenever the pressure exceeds the design threshold and allow the pressurized fluid to escape from the bottom stage of the cylinder. This loss of fluid causes the pressure to drop in the bottom stage until the valve reseats. The reseating pressure is typically about 90% of the yield pressure; thus, the support capacity will drop by approximately 10% when the yield valve opens. As the pressure drops in the bottom stage, a force imbalance occurs between the top and bottom stage, which causes the bottom stage to lower until force equilibrium is attained. The top-stage extension does not change during yielding until the bottom stage is fully collapsed.

How much the bottom stage lowers because of yielding depends on three factors: (1) the area of the bottom stage, (2) the extension of the bottom stage, and (3) the yield pressure and reseating pressure of the yield valve. The reduction in support height due to yielding will be more for large extensions of the bottom stage than for small extensions of the bottom stage, decreasing in direct proportion to reductions in the bottom-stage extension at the time of yielding. Thus, on each successive yielding during any one operating cycle, the lowering of the bottom stage will be progressively less. The magnitude of bottom-stage lowering due to yielding can be calculated using equations 2 and 3. Using a 700-ton longwall shield with a bottom-stage diameter of 11.8 in and a yield pressure of 6,389 psi as an example, the bottom stage of each hydraulic cylinder will drop approximately 0.028 in during a single yield event if the bottom stage was extended 14 in when yielding began. A 70-ton reduction in support loading would be caused by the yielding.

$$\Delta V = \frac{\Delta P * V}{\beta}, \tag{2}$$

where ΔV = change in volume of fluid in bottom stage of cylinder, in³;
 ΔP = change in hydraulic pressure in bottom stage of cylinder, psi;
 ΔP = yield pressure minus reseating pressure, psi;
 V = volume of fluid in bottom stage at time of yielding, in³;
 V = area of bottom stage times extension of bottom stage, in³; and
 β = bulk modulus of oil, psi (i.e., 320,000 psi).

$$\Delta D = \frac{\Delta V}{A}, \tag{3}$$

where ΔD = reduction in bottom-stage extension due to yielding, in;
 ΔV = reduction in volume of fluid in bottom stage due to yielding, in³; and
 A = area of bottom stage, in².

DETECTION OF HYDRAULIC FAILURES

It is important to realize that all shields will experience leakages due to seal wear and/or component failures several times during their life expectancy in the mine. Also, many of these failures will go undetected for extended periods of time, resulting in significantly degraded shield capacity and ground control capability. Furthermore, if shield life is to be maximized, then recognition and correction of hydraulic failures are important. If both leg cylinders are not functioning properly, eccentric loading in the canopy and caving shield-lemniscate assembly, for example, will be created, causing increased probability of structural failure in these components. Additional loading may be transferred onto adjacent shields, thereby reducing their life expectancy. Degraded support capacity may induce more severe weighting of the shields, creating a snowball effect that further degrades the support capability.

Observations of the relative positions of the cylinder staging can be used to identify cylinder problems and the cause of hydraulic leakages. One indication of internal leakages is when the bottom stage is consistently fully extended. The bottom stage should be fully extended only on operating cycles that establish a new maximum operating height. Thus, on the majority of operating cycles, the bottom stage should not be at full extension. Another indication of hydraulic leakage is when there is a large difference in stage extensions of leg cylinders on the same support (figure 24). Observation of the bottom-stage position can help to identify the component failure (table 1).

Table 1.—Stage movements associated with internal component failures

Component failure	Bottom-stage movement
Staging check valve	Up.
First-stage seals	Down.
Second-stage seals	Up.
Pilot-operated check valve . . .	Down.
Yield valve	Down.

Problems with the staging check valve can be isolated by fully collapsing the shield and monitoring the leg pressures on the operating cycle after the support is reset against the mine roof and floor. The requirement is to have the bottom stage fully extended when the support is reset. In this configuration with a staging check valve that is functioning properly, the pressure in the bottom stage will not change significantly until the force in the top stage due to additional roof loading overcomes the setting force developed in the bottom stage (figure 25). An immediate increase in pressure in the bottom stage indicates that the check valve is leaking sufficiently to not allow the pressure in the top stage to be intensified.

Two factors that reduce hydraulic life expectancy are contamination and corrosion. It is very important to change filters as needed to maintain a clean emulsion. Debris in the leg cylinder is a leading cause of stage valves failures, which reduce shield capacity by 40% to 60%. Debris also reduces seal life and can cause check valves and yield valves to malfunction. Corrosion is also a primary factor in leg cylinder life. A chemical analysis of the emulsion fluid should be done periodically. Bacteria growth or poor water quality can significantly reduce the life of the leg cylinders.

From the design and repair perspective, there have been improvements in plating technology, which has reduced the corrosion problem in recent years. Early shield designs used chrome plating for the leg cylinder bores. Chrome is a very porous material, and even if the thickness is increased, the structure, which is analogous to placing layers of chicken wire on top of each other, remains quite porous. Bronze is a much better material, and most shield cylinders are now plated with

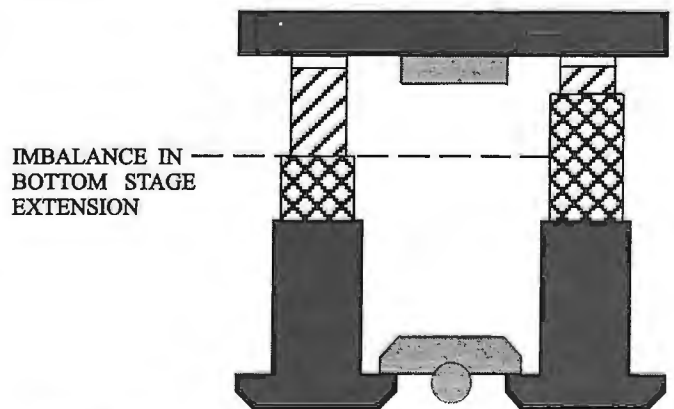

Figure 24.—Imbalance in leg cylinder staging due to internal leakage.

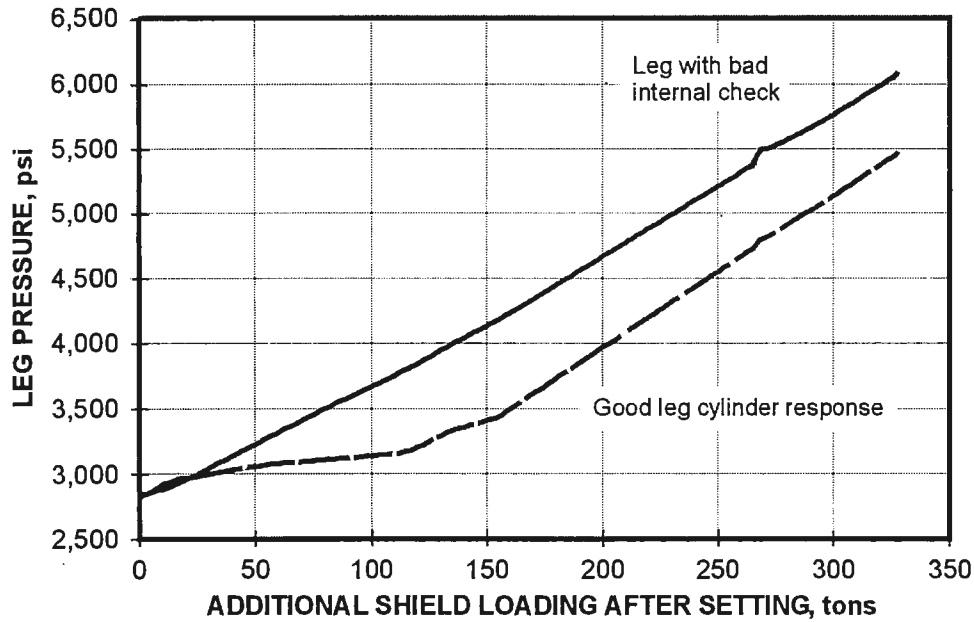

Figure 25.—Identification of defective leg cylinder staging valve.

bronze. The harder the bronze is, the better the life that can be expected. An alternative to bronze is to use chrome over top of nickel plating. The electrolysis of the nickel creates a very hard material that is highly corrosion-resistant, but the process is also considerably more expensive. Another problem with using nickel as the base metal in the plating process is that the two metals tend to react with one another, reducing the bond between them, which causes the chrome to peel off in time.

An impending problem with current plating technology are the environmental hazards associated with the plating process. Both chrome and bronze plating present environmental hazards that are likely to drive up the cost of these conventional plating methods in the near future. Since rebuilding of shield leg cylinders is a routine part of extended shield operation on every longwall, this can have a significant impact on the mining industry, and new plating technologies need to be explored. Swanson Plating, Morgantown, WV, is now offering laser-controlled plating as an alternative. The laser technology, in addition to being more environmentally friendly, reduces the heat affected zone by nearly two orders of magnitude and allows for much more controlled plating using materials that cannot be applied by conventional plating practices. More innovative solutions to consider would be the use of ceramic or composite materials that are much more corrosion-resistant than the heavy metals currently used in cylinder construction.

ERRORS IN ASSESSING SUPPORT LOADING

Support loading is determined from measurement of the pressure in the bottom stage of the hydraulic cylinder. Since the pressure increases in direct proportion to the increase in support loading, this provides an accurate assessment of the roof loading through the full loading cycle. However, when the bottom stage is fully stroked, a portion of the increase in roof

loading after the support is set against the mine roof and floor will not be detected by changes in hydraulic pressure in the bottom stage. The reason for this period of undetected roof loading is that when the bottom stage is fully extended, the bottom-stage piston is being held against the mechanical stops with a force exerted by the pump pressure at the time the support was set. The pressure in the bottom stage will only increase when this piston is moved off of the stops and begins to compress the hydraulic fluid in the bottom stage. In order for this to happen, the pressure in the upper stage, which is at pump pressure when the support is set, must increase to cause a force in the upper stage that exceeds the setting force in the bottom stage. The additional roof loading that is required to produce this additional force in the upper stage is the roof loading that is undetected by the pressure gauges measuring hydraulic pressure in the bottom stage.

The mechanics of the pressure development in the various support stages can be described by examination of equilibrium requirements for each individual stage, realizing that each stage must carry the same load. The undetected roof loading with the bottom stage fully extended can be calculated using equation 4. An examination of these principles indicates that the period and magnitude of undetected roof loading will increase as the setting pressure increases for a particular support.

where URL = undetected roof load, tons;

$$URL = \frac{(A_2 * P_2) - (A_1 * P_1)}{2000}, \tag{4}$$

- A₁ = area of first (bottom) stage, in²;
- A₂ = area of second stage, in²; and
- P₁ = P₂ = setting (pump) pressure, psi.

Figure 26 depicts undetected roof loading for a 700-ton (two-stage) longwall shield set at full pump pressure. It is seen

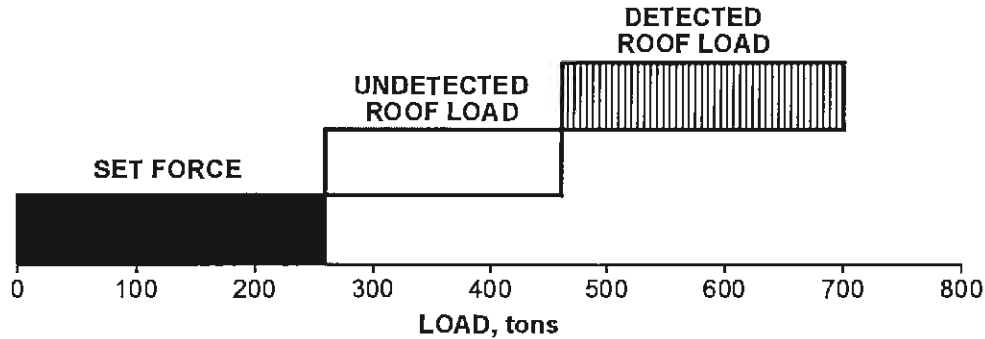

Figure 26.—Undetected roof loaded by bottom-stage pressure measurements when bottom stage is fully extended during setting of the shield.

from this figure that the unrecorded roof loading is quite large. For example, approximately 200 tons of undetected roof loading, which represents 84% of the remaining shield

capacity, will occur on the 700-ton longwall after it is set against the mine roof and floor.

CONCLUSIONS AND RECOMMENDATIONS

The evolution of improved shield design continues with the current generation of shield supports. The previous generation of shield supports (1985-95 era) experienced several serious structural failures. These included canopy sections falling off, bases cracking in half, leg sockets pushing through the base and canopy into the mine roof and floor, lemniscate links breaking, and pins bending and breaking. Generally, these problems have been addressed by the support manufacturers. However, as the capacities continue to grow, each new generation of shield supports must also experience the growing pains of design deficiencies. This is occurring now as isolated failures of modern shield design are again cropping up.

While proper shield design is not magic, there is an experience factor that cannot be overlooked. Unlike designing a building or a bridge where the load conditions are well known and fail-safe design philosophies can be readily employed, the mining environment is not well defined or easily understood. Mining engineers typically design to allow failure, while conventional structural engineers design to prevent failure. Furthermore, as the demand for extended shield life continues to grow, continued improvements in quality control and innovations in shield design must be developed if this requirement is to be realized.

Although the design of longwall shields is a complex issue, it would be beneficial to prospective shield buyers to learn the basic engineering principles associated with shield design issues that are addressed in this paper. Although it is not necessary to know all of the answers, knowing what questions to ask is important. Hiring a structural engineering consultant is another option, but again one must be aware of the uniqueness of the mining environment and shield design issues.

Corrosion is by far the most overlooked factor in both shield design and performance testing. Corrosion control practices are limited, but they need to be followed. Simple things such as

using corrosion-resistant paint and repainting of shields can be effective. Design changes need to be made to the pin joints and clevises, which are subjected to high wear rates, to avoid corrosion in these areas. Advanced plating technologies and more corrosive-resistant materials need to be employed to improve hydraulic cylinder life, which is by far the weak link in a shield's lifeline.

Support failures are site-specific, and the magnitude of the problem must be considered in making judgments of support safety. The information provided in this paper will help identify problems and suggest solutions. However, the final judgment must be made with considerations of the severity of the problem, number of supports affected, past performance history, face conditions at the time of failure, and the overall situation at the mine site. Finally, the best policy is always to correct problems as soon as they occur. Although this is often impractical and at times impossible, these generic recommendations regarding safety precautions of problem support systems are made with the realization that they are not universal for all circumstances:

1. When failures occur, procedures to reduce shield load should be implemented.

A good practice to reduce face weighting is to maximize the rate of advance. Idle faces generally have a tendency to create higher shield loads. Also, setting forces should be optimized. Conventional wisdom has been to increase the set pressures or to ensure that full setting (pump) pressure is maintained. However, in displacement-controlled loading where the load development is proportional to the shield stiffness and the support resistance is not fully controlling the ground movements, reducing the setting loads may also be an option to reduce the total loading on the support. Another possibility is to reduce

the depth of the shearer cut. Much of the shield loading is generated from the shearer pass. A reduced cut may reduce shield loading, although there are no data to substantiate this hypothesis.

2. Ensure proper operation of the support once it is put into service.

Another issue related to lowering the design stress is to ensure proper operation of the support once it is put into service in the mine. Stress developments are greatly enhanced whenever the support is stood on the toe of the base. When a shield is set with the canopy tip up, the leg forces will typically rotate the canopy into full roof contact and in the process lift the rear of the base off of the ground. This base-on-toe configuration increases the magnitude of stress in the lemniscate links by as much as 300%. Modern two-leg shields employ a control system for the canopy capsule cylinder that prevents setting the shield with the canopy tip up. Thus, if this system is deactivated by the mine personnel, the life expectancy of the pin joints and the entire shield can be significantly shortened.

3. Recognize the cumulative effect of degraded performance and noncatastrophic failures.

As previously discussed, it is quite common for aging shields to experience hydraulic leaks that lead to degraded support capacity, but typically do not interfere significantly with the stability of the support or its capability to remain functional. Whenever the degraded support capacity is accompanied by a lack of ground control, obviously the problems must be corrected immediately. However, with modern high-capacity supports this is generally not the case, and the question is how soon the degraded leg cylinder performance should be corrected. In many cases, leakage will occur in only one leg or be considerably worse in one leg compared to the other. From a load distribution viewpoint, loads will transfer down the side of the structure with the active leg. This imbalance in leg forces will cause some increase in component stresses, particularly in the caving shield and lemniscate assembly. Although this generally will not pose an immediate threat, the cumulative effect of the increased loading, if left unattended, will more than likely decrease the shield life by accelerating fatigue-related failures. Furthermore, if structural failures do occur, the asymmetric loading caused by imbalanced leg forces will likely make these failures more severe.

This same logic applies to structural failures. There is considerable redundancy built into a shield support in the sense that there are multiple load paths to transfer roof loading through the support structure and into the mine floor. Most failures when they first occur will not immediately affect the performance of the support. However, once a failure initiates, a domino effect will likely occur wherein additional loading is transferred elsewhere, and the probability for the failure to grow or spread to other components as time progresses is also likely.

4. While fatigue failures are difficult to judge, they can lead to catastrophic failure with little or no warning.

Modern shields of high-strength steel are more susceptible to unstable failure than previous generations of shields constructed from mild steel. Crack formation in any part of the support structure should be viewed as a sign of potentially imminent danger. The crack indicates that the steel has failed. Whether this crack will propagate to cause destruction of a support component depends on many things, most notably, the ability of the member to effectively redistribute loading primarily within that component or, to a lesser degree, to other components. This makes judgments of support safety in these situations difficult. In any event, cracks in a support structure should be closely monitored, and attention should be given to any increase in the growth and particularly the rate of growth of the crack. Cracks that arrest themselves after formation can often be ignored, particularly when they are in sections of the support that do not carry the bulk of the loading. In this case, load was adequately transferred elsewhere to alleviate the localized stress condition that initiated the crack. Conversely, a crack that continues to grow after formation is likely to develop into a critical situation where the safe performance of the support is threatened. Obviously, as soon as the structural integrity of the support (component) is threatened, the support should be taken out of service and modifications made. Once a critical crack length is reached, the growth rate can accelerate in relatively few additional loading cycles. Particular attention should be paid to weldments, since localized stress developments are likely to be higher in these areas and the potential for rapid crack growth is enhanced.

5. Recognize failures that can lead to instability and correct them immediately.

It is unlikely that the support will show any signs of diminished load-carrying capability while structural problems are developing, but the stability of the support may be threatened. Failures to the caving shield or lemniscate link pins or to the links themselves are most serious since they control the horizontal stability of the shield. Failure of any set of link pins or links will cause the support to collapse under its own weight from instability. There is redundancy built into the shield in that there are pairs (left and right side) of both the upper and lower links. Failure of one side may not result in immediate instability, but will significantly increase loading in the adjacent link and therefore should be viewed as very serious, with immediate action taken to remove the failed pin and install a new one.

Another serious failure that can lead to instability is failure of the leg sockets. The leg sockets must transfer loading from the canopy to the base. If the sockets break loose, the cylinder will eventually punch through the bottom plate on the base and render the support inoperable and perhaps unstable.

6. *Understand the hazards of automated control systems.*

During the early development of the electrohydraulic control systems with automated and shearer-initiated advance, several injuries occurred because of unplanned or unexpected shield movements. Although failures in the electronics have largely been eliminated in recent years, occasional injuries still occur

where a miner is unaware of the pending shield move, which was initiated at a remote position by another miner. Close attention should be paid to the audible warning of the shield advance. A good practice is to walk on the bases of the support whenever possible to avoid being pinched by an unexpected shield move.

REFERENCES

American Institute of Steel Construction [1980]. Manual of steel construction. 8th ed. Chicago, IL: American Institute of Steel Construction, pp. 5-89.

Barczak TM, Gearhart DF [1998]. Performance and safety considerations of hydraulic support systems. In: Peng SS, ed. Proceedings of the 17th International Conference on Ground Control in Mining. Morgantown, WV: University of West Virginia, pp. 176-186.

Barczak TM, Chekan GJ, Babich DR [1998]. Shield design, construction, and operation. In: Proceedings of Longwall USA International Exhibition & Conference, pp. 5-47.

Barsom JM, Rolfe ST [1987]. Fracture and fatigue control in structures. Englewood Cliffs, NJ: Prentice-Hall Inc.

Fiscor S [1999]. U.S. longwall census '99. *Coal Age Feb*:30-35.

Information Circular 9453

**Proceedings: New Technology For Coal Mine
Roof Support**

U.S. DEPARTMENT OF HEALTH AND HUMAN SERVICES
Public Health Service
Centers for Disease Control and Prevention
National Institute for Occupational Safety and Health
Pittsburgh Research Laboratory
Pittsburgh, PA

October 2000

ORDERING INFORMATION

Copies of National Institute for Occupational Safety and Health (NIOSH)
documents and information
about occupational safety and health are available from

NIOSH—Publications Dissemination
4676 Columbia Parkway
Cincinnati, OH 45226-1998

Fax: 513-533-8573
Telephone: 1-800-35-NIOSH
(1-800-356-4674)
E-mail: pubstaft@cdc.gov
Web site: www.cdc.gov/niosh

This document is the public domain and may be freely copied or reprinted.

Disclaimer: Mention of any company or product does not constitute endorsement by NIOSH.