

PB192413



A PROCESS TO MAKE HIGH-BTU GAS FROM COAL

by

Albert J. Forney, Stanley J. Gasior,
William P. Haynes, and Sidney Katell

Bureau of Mines Coal Gasification Program

Technical Progress Report - 24

April 1970

U.S. DEPARTMENT OF THE INTERIOR

Page Intentionally Left Blank

CONTENTS

	<u>Page</u>
Abstract.....	1
Introduction.....	1
The gasification-methanation system.....	2
Costs for the process.....	4
Conclusion.....	5
References.....	6

ILLUSTRATIONS

1. System used to make high-Btu gas from coal.....	2
2. Forty-atmosphere fluid-bed gasifier.....	3
3. Simplified flowsheet of tube-wall pilot plant for producing high-Btu gas.....	5

TABLE

1. Gasification of fine-size coals at 40-atmosphere pressure.....	4
---	---

A PROCESS TO MAKE HIGH-BTU GAS FROM COAL

by

Albert J. Forney,¹ Stanley J. Gasior,² William P. Haynes,³
and Sidney Katell⁴

ABSTRACT

A process for the manufacture of high-Btu gas from coal has been developed by the Bureau of Mines. The process consists of fluid-bed gasification of the coal, followed by the gas treatment steps of gas purification and methanation. Advantages of the system are that caking coals can be used directly, and more than half of the ultimate methane is made in the gasifier.

INTRODUCTION

Natural gas now provides more than 31 percent of the total energy demand of the country. The 21 trillion cubic feet of gas produced in 1969 must be sharply increased if the demand is to be met from domestic sources. Much concern has been expressed by the American Gas Association and the Federal Power Commission over the impending shortage of gas.

While the reserves-to-production ratio has been declining, the cost of natural gas has been steadily rising. Thus, alternate sources of supplemental gas will soon be able to compete with the natural domestic product in a more favorable economic framework than at present. Some coal-to-gas processes appear to be competitive today in some gas-consuming areas.

The distribution of coal over the country plus its abundance make pipeline gas from coal economically attractive, especially with the new advances in coal technology. This paper describes a Bureau of Mines process which technically and economically compares favorably with other processes to produce a pipeline gas from coal.

¹ Project coordinator, Pittsburgh Coal Research Center, Bureau of Mines, Pittsburgh, Pa.

² Chemical research engineer, Pittsburgh Coal Research Center, Bureau of Mines, Pittsburgh, Pa.

³ Supervisory chemical research engineer, Pittsburgh Coal Research Center, Bureau of Mines, Pittsburgh, Pa.

⁴ Chief, Process Evaluation Group, Morgantown Coal Research Center, Bureau of Mines, Morgantown, W. Va.

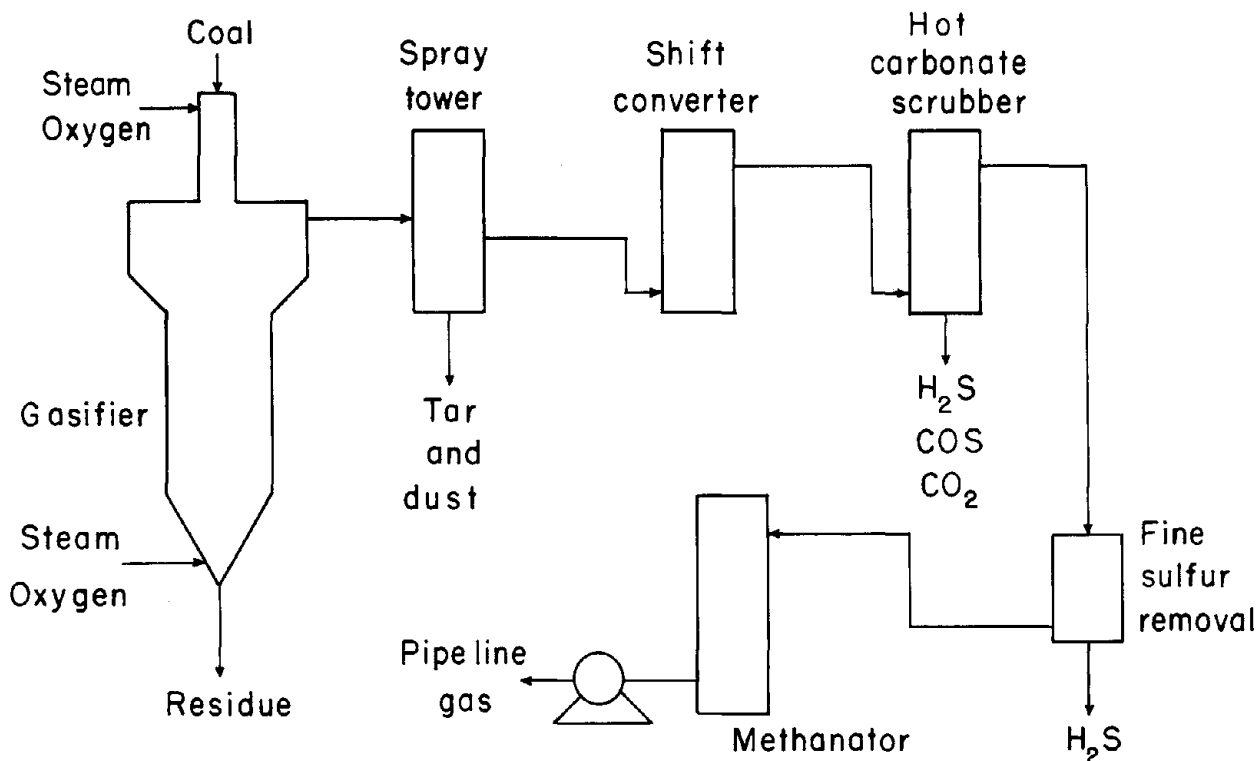

FIGURE 1. - System Used To Make High-Btu Gas From Coal.

THE GASIFICATION-METHANATION SYSTEM

A schematic of the overall system for making high-Btu gas from coal is shown in figure 1. The main components are the gasifier, the shift converter, the purification system, and the methanator.

To permit gasification of caking coals, the Bureau of Mines unit integrates three processing steps: pretreatment in free-fall for the destruction of the caking quality of the coal, carbonization in dense fluid bed, and gasification of the residue in a dilute fluid bed. An extractor removes the ash from the bottom of the gasifier. Most tests were made with a Pittsburgh seam coal of high-caking quality, with a free-swelling index of 8 to $8\frac{1}{2}$. Since highly caking coal was pretreated in the gasifier, any other coal can probably be satisfactorily pretreated. Illinois No. 6 coal, Montana subbituminous coal, and North Dakota lignite were also gasified. The dust and tar are removed from the gas, and the gas then is shifted to the proper ratio of $3H_2$ to $1CO$ for methanation.

The purification system uses hot potassium carbonate (2)⁵ which reduces the CO_2 to 2.0 percent and removes most of the sulfur compounds. After fine sulfur cleanup, the purified product gas (about 500 Btu/cu ft) is methanated to make a high-Btu gas, exceeding 900 Btu/cu ft. The shift and purification

⁵Underlined numbers in parentheses refer to items in the list of references at the end of this report.

systems are commercial so the researchers at the Bureau are concentrating on the gasification and methanation steps.

Figure 2 is a schematic diagram of the free-fall, fluid-bed gasifier pilot plant. The system is designed to operate at 40 atmospheres and 950° C (1,742° F) in the gasification section and at 400° C (752° F) in the pre-treating section. The pretreater is a 2-inch-diameter tube that is 8 feet high. As the coal falls through this tube, it is pretreated by oxygen (0.3 to 0.8 scf/lb coal) plus a diluent, either steam or CO₂. The pretreated coal then enters the expanded section of the gasifier (10 inch diameter by 3 feet high)

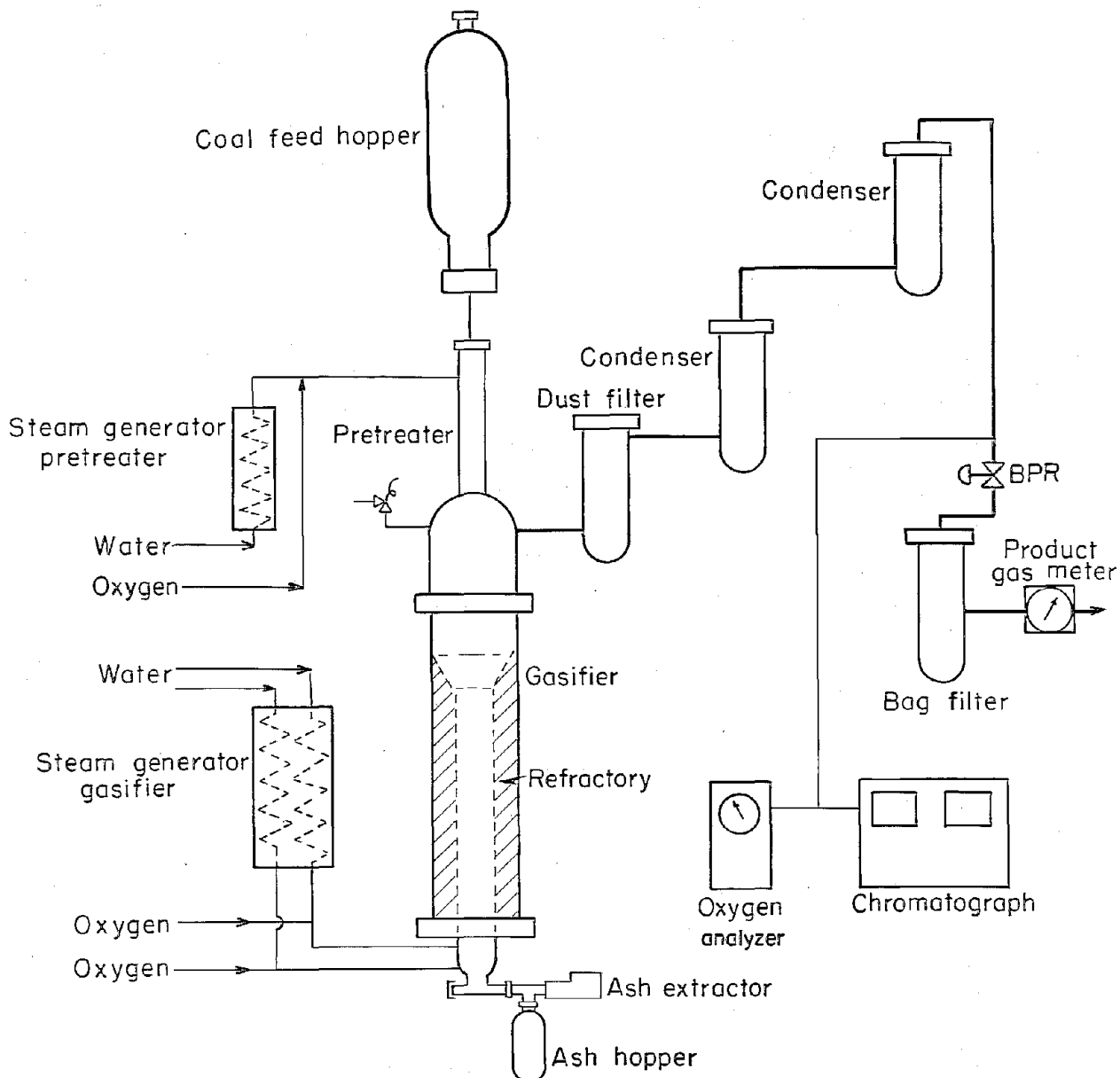

FIGURE 2. - Forty-Atmosphere Fluid-Bed Gasifier.

where it is carbonized. The gasifier is 4 inches in diameter by 6 feet high inside a 10-inch-diameter shell; the annulus contains poured refractory. The fluidization gas consists of oxygen (4 scf/lb coal) plus steam (20 to 30 scf/lb coal). Selected data taken from gasification tests are shown in table 1. Results from tests with Pittsburgh seam coal and Illinois No. 6 coal are shown, as well as the goals desired. As seen in table 1, the goals of coal throughput, carbon conversion, and the quantity of make gas were achieved, but the goals for the percentage of CH_4 in the product gas and the yield of CH_4 per pound of moisture- and ash-free coal were not completely achieved. This was probably due to oxygen input into the upper part of the fluidized section to compensate for the high heat losses inherent in this small-size, high-temperature pilot plant. The system has the advantages of operating with caking coals; also, the yield of methane should be much higher than in other steam-oxygen gasifiers.

TABLE 1. - Gasification of fine-size coals at 40-atmosphere pressure

	Pittsburgh seam	Illinois No. 6	Desired goals
Coal feed rate.....lb/hr ft ³ ..	23	20	23
Carbon conversion.....percent..	67	72	65
Purified product gas...scf/lb MAF ¹ coal..	17	18	17
CH_4percent of purified gas..	23	21	27
CH_4scf/lb MAF ¹ coal..	3.9	3.7	4.4
Tar.....percent of coal feed..	3.6	3.4	-

¹Moisture- and ash-free.

For the methanation step, the Bureau is developing a tube-wall reactor (1, 3) that uses a flame-sprayed Raney⁶ nickel catalyst.

The high exothermic heat of the reaction (65 Btu/cu ft of $3\text{H}_2 + \text{CO}$ reacting) necessitates a very efficient heat exchanger to remove this heat from the catalyst surface. In the tube-wall reactor (fig. 3) excellent heat transfer is made through the catalyst-coated tube to boiling Dowtherm. The methanation system operates at about 400° C (752° F) and at 400 to 600 psia. The feed rate of gas is 100 to 120 scfh/ft² of catalyst surface, and the product gas consists of about 90 percent CH_4 with small amounts of H_2 , CO_2 , and N_2 . Because of its high throughput and low compression costs, we are concentrating our research on the further development of this reactor system.

COSTS FOR THE PROCESS

The Process Evaluation Group has made a preliminary economic evaluation of an integrated plant designed to produce 250 million scfd of 930-Btu gas by fluidized gasification, followed by shift conversion, purification, and methanation. The total capital investment is estimated at \$165 million; the annual operating cost is estimated at 43 cents per thousand cubic feet. Calculated on the basis of the gas industry's financial structure and average

⁶Reference to specific brands is made for identification only and does not imply endorsement by the Bureau of Mines.

REFERENCES

1. Demeter, J. J., A. J. Youngblood, J. H. Field, and D. Bienstock. Synthesis of High-Btu Gas in a Raney-Nickel Coated Tube-Wall Reactor. BuMines Rept. of Inv. 7033, 1967, 17 pp.
2. Field, J. H., H. E. Benson, G. E. Johnson, J. B. Tosh, and A. J. Forney. Pilot Plant Studies of the Hot Carbonate Process for Removing Carbon Dioxide and Hydrogen Sulfide. BuMines Bull. 597, 1962, 44 pp.
3. Field, J. H., and A. J. Forney. High-Btu Gas Via Fluid-Bed Gasification of Caking Coal and Catalytic Methanation. Bound Proceedings of Synthetic Pipeline Gas Symposium, American Gas Association, Pittsburgh, Pa., November 1966, pp. 83-94.