

PB80202252



NBS-114A (REV. 9-78)

U.S. DEPT. OF COMM. BIBLIOGRAPHIC DATA SHEET	1. PUBLICATION OR REPORT NO. NBS BSS 127	3. Recipient's Accession No. PB 80 202252	
4. TITLE AND SUBTITLE Recommended Technical Provisions for Construction Practice in Shoring and Sloping of Trenches and Excavations		5. Publication Date June 1980	
7. AUTHOR(S) Felix Y. Yokel		6. Performing Organization Name	
9. PERFORMING ORGANIZATION NAME AND ADDRESS NATIONAL BUREAU OF STANDARDS DEPARTMENT OF COMMERCE WASHINGTON, DC 20234		8. Performing Organ. Report No.	
12. SPONSORING ORGANIZATION NAME AND COMPLETE ADDRESS (Street, City, State, ZIP) Occupational Safety and Health Adm. Nat. Inst. for Occupational Safety and Health Department of Labor Dept. of HEW Washington, D.C. 20210 Washington, D.C. 20201		10. Project/Task/Work Unit No.	
15. SUPPLEMENTARY NOTES <input type="checkbox"/> Document describes a computer program; SF-185, FIPS Software Summary, is attached.		11. Contract/Grant No.	
16. ABSTRACT (A 200-word or less factual summary of most significant information. If document includes a significant bibliography or literature survey, mention it here.) On the basis of studies conducted by the National Bureau of Standards technical provisions for the sloping and shoring of the banks of trenches and excavations are recommended. Included are a recommended standard practice for trenching which can be used by construction supervisors and compliance officers of the Occupational Safety and Health Administration, and proposed engineering guidelines for the design of shoring systems and other means to prevent mass movement of soil or rock in excavations.		13. Type of Report & Period Covered Final	
17. KEY WORDS (six to twelve entries; alphabetical order; capitalize only the first letter of the first key word unless a proper name; separated by semicolons) Braced excavation; construction; retaining structures; shoring; slope stability; soil classification; soil pressure; standards; trenching		14. Sponsoring Agency Code	
18. AVAILABILITY <input checked="" type="checkbox"/> Unlimited <input type="checkbox"/> For Official Distribution. Do Not Release to NTIS	19. SECURITY CLASS (THIS REPORT) UNCLASSIFIED	21. NO. OF PRINTED PAGES 84	
<input checked="" type="checkbox"/> Order From National Technical Information Service (NTIS), Springfield, VA. 22161	20. SECURITY CLASS (THIS PAGE) UNCLASSIFIED	22. Price	

USCOMM-DC

REPRODUCED BY
U.S. DEPARTMENT OF COMMERCE
NATIONAL TECHNICAL
INFORMATION SERVICE
SPRINGFIELD, VA 22161

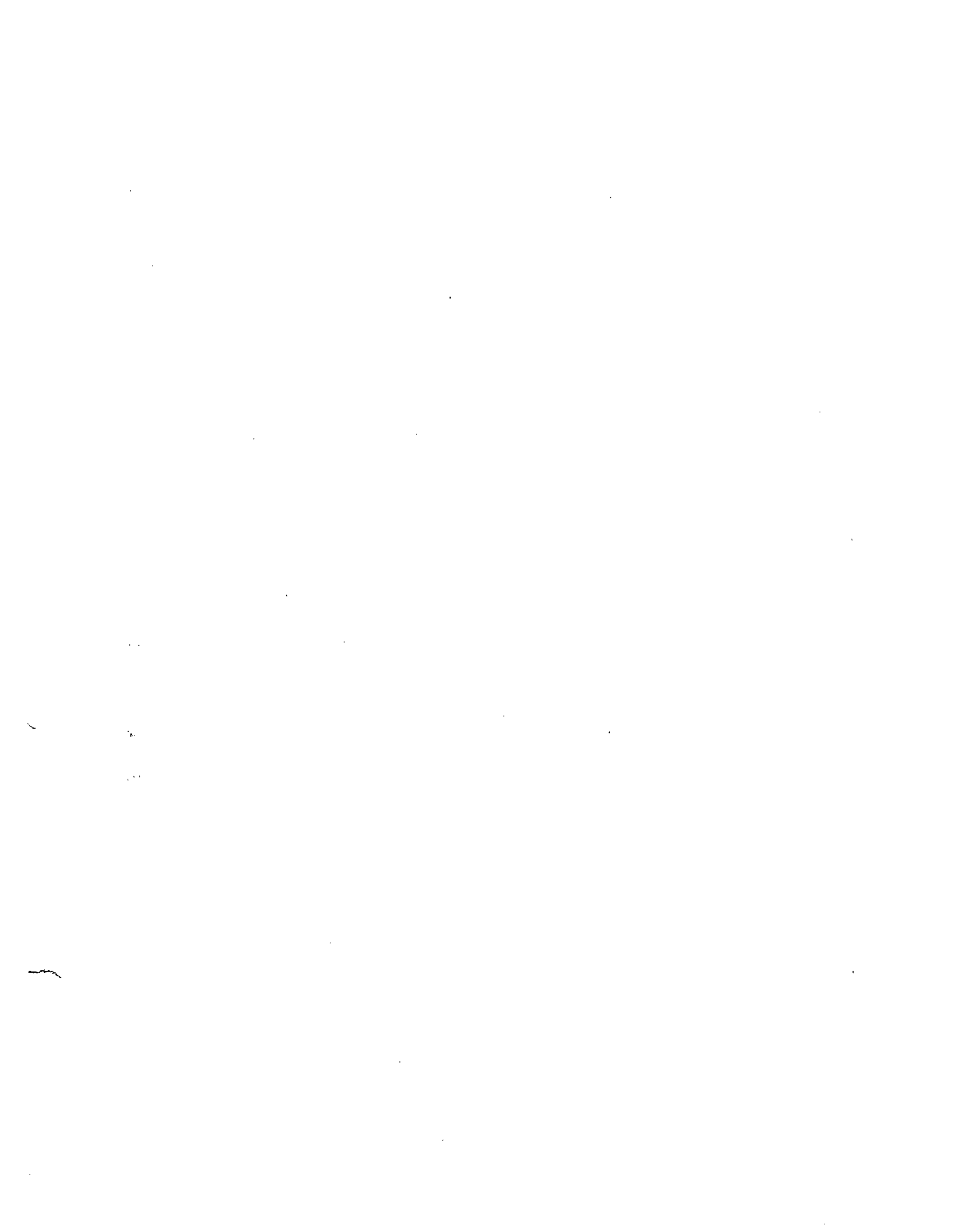

NOTICE

THIS DOCUMENT HAS BEEN REPRODUCED FROM THE BEST COPY FURNISHED NTIS BY THE SPONSORING AGENCY. ALTHOUGH IT'S RECOGNIZED THAT CERTAIN PORTIONS ARE ILLEGIBLE, IT IS BEING RELEASED IN THE INTEREST OF MAKING AVAILABLE AS MUCH INFORMATION AS POSSIBLE.



ERRATA TO ACCOMPANY NATIONAL BUREAU OF STANDARDS
BUILDING SCIENCE SERIES 127

Recommended Technical Provisions for
Construction Practice in Shoring and
Sloping of Trenches and Excavations

Felix Y. Yokel

- | | <u>Item</u> | | <u>Change</u> |
|----------|------------------------------------------|--|----------------------------------------------|
| Page XIV | - Skeleton Sheating | | Skeleton Sheathing |
| Page 10 | - Second line from bottom of page | | w_e = equivalent weight effect
in . . . |
| Page 38 | - Third line from bottom is corrected as | | $R_s = \frac{k_a (\phi=0)}{k_a (\phi=0)}$ |
| Page 56 | - Second line from bottom should read | | and guidance throughout. . . |
| Page 68 | - Table A.9 should read as follows: | | |

Table A.9 Timber Shoring Wale Sizes in Accordance with Standard Practice

Trench Depth (ft)	Soil Type	Horizontal Strut Spacing (ft)						Sheeting Thickness (in)
		6	8	10	12	14	16	
5-10	B	6 x 8	8 x 10	10 x 10	10 x 10	10 x 12	12 x 12	2
	C	8 x 10	10 x 12	12 x 12*	12 x 12			3
10-15	B	8 x 8	10 x 10	10 x 12*	10 x 12	12 x 12		2
	C	10 x 12	12 x 12*	12 x 12				3
15-20	B	8 x 10	10 x 12	12 x 12*	12 x 12			3
	C	12 x 12	12 x 12					3

← USE INTERMEDIATE STRUTS TO THE RIGHT OF LINE

- (1) All lumber sizes are actual (not nominal) sizes in inches.
- (2) Vertical spacing not to exceed 5 ft center-to-center.
- (3) All horizontal spacing is center-to-center.
- (4) Long side of cross-section of rectangular members to be horizontal.
- (5) * indicates slight overstress.
- (6) Wale sizes to the right of dividing line require insertion of intermediate strut before workers enter the trench.
- (7) If vertical distance from the center of the lowest wale to the bottom of the trench exceeds 2 1/2 ft, sheeting shall be firmly embedded below the bottom of the trench or mudsill shall be used. The vertical distance from the center of the lowest wale to the bottom of the trench shall not exceed 3 ft, or 3 1/2 ft if mudsill is used.

NBS BUILDING SCIENCE SERIES 127

Recommended Technical Provisions for Construction Practice in Shoring and Sloping of Trenches and Excavations

Felix Y. Yokel

Center for Building Technology
National Engineering Laboratory
National Bureau of Standards
Washington, DC 20234

Prepared for the
Occupational Safety and
Health Administration
Department of Labor
Washington, D.C. 20210

and

National Institute for Occupational Safety
and Health
Department of Health, Education and Welfare
Washington, D.C. 20201



U.S. DEPARTMENT OF COMMERCE, Philip M. Klutznick, Secretary

Luther H. Hodges, Jr., Deputy Secretary

Jordan J. Baruch, Assistant Secretary for Productivity, Technology and Innovation

NATIONAL BUREAU OF STANDARDS, Ernest Ambler, Director

Issued June 1980

i-A

Library of Congress Catalog Card Number: 80-600068

National Bureau of Standards Building Science Series 127

Nat. Bur. Stand. (U.S.), Bldg. Sci. Ser. 127, 84 pages (June 1980)

CODEN: BSSNBV

**U.S. GOVERNMENT PRINTING OFFICE
WASHINGTON: 1980**

ABSTRACT

On the basis of studies conducted by the National Bureau of Standards technical provisions for the sloping and shoring of the banks of trenches and excavations are recommended. Included are a recommended standard practice for trenching which can be used by construction supervisors and compliance officers of the Occupational Safety and Health Administration, and proposed engineering guidelines for the design of shoring systems and other means to prevent mass movement of soil or rock in excavations.

Key words: Braced excavation; construction; retaining structures; shoring; slope stability; soil classification; soil pressure; standards; trenching.

COVER: One of the problems encountered in many trenching operations is a narrow work space (courtesy, National Utility Contractors Association, Washington, D.C.)

PREFACE

The Occupational Safety and Health Administration (OSHA) Regulations for Excavation, Trenching and Shoring [13]^{1/} were promulgated in April 1971. In June 1976, OSHA engaged the National Bureau of Standards to study the compatibility of the technical provisions in these regulations with actual construction practice and with the state of knowledge in geotechnical and structural engineering, review the experience accumulated since their promulgation and recommend potential modifications that could improve their effectiveness. The NBS study consisted of three parts: A field study of present practice in excavation, trenching and shoring and the impact of the OSHA regulations as perceived by contractors, labor unions and State and Federal enforcement agencies; a technical study consisting of the assessment of the technical provisions in the present regulations and of available options for improving the soil classification method and the technical provisions for sloping and shoring; and a study of timber presently used for shoring in order to reasonably assess the load carrying capacity of timber shoring systems. Initial guidance was also provided by a trenching hazards identification task force appointment by the Building and Construction Trades Department of AFL-CIO who organized a workshop to identify excavation safety problems. The findings of this work are presented in separate reports on the field study, [10, 17], the soil classification study [21] and the shoring timber study [11], respectively. This report contains recommendations which are based on those findings. A draft of initial recommendations was discussed at a workshop which was held in September 1978 [16]. As a result of this workshop some of the original recommendations were re-studied and subsequently modified.

The study was conducted by the Geotechnical Engineering Group of the Center for Building Technology. The preparation of this report was funded in part by the National Institute for Occupational Health and Safety (NIOSH).

^{1/} Numbers in brackets refer to literature references in Section 6.

TABLE OF CONTENTS

	<u>Page</u>
List of Figures	vii
List of Tables	viii
List of Symbols	ix
SI Conversion Units	xii
Definitions	xiii
1. INTRODUCTION	1
2. ACCEPTABLE PRACTICE	3
3. RECOMMENDED STANDARD PRACTICE	7
3.1 Scope	7
3.2 Sloped Excavations	8
3.3 Shored Excavations	8
3.3.1 Strength of Shoring Systems	8
3.3.2 Loads Acting on Shoring Systems	10
3.3.3 Rating of Shoring Systems	11
3.3.4 Determination of Load Capacity by Test	14
3.4 Soil Classification	15
3.4.1 General	15
3.4.2 Simplified Soil Classification System	15
3.4.3 Matrix Soil Classification System	15
3.5 Spaced Sheet piling	15
3.5.1 General	15
3.5.2 Strength of Spaced Sheet piling	19
3.5.3 Maximum Spacing of Spaced Sheet piling	19
3.6 Recommended Special Provisions	20
4. ENGINEERING GUIDELINES FOR THE DESIGN OF SHORING SYSTEMS AND OTHER MEANS TO PREVENT MASS MOVEMENT OF SOIL AND ROCK ..	23
4.1 General	23
4.2 Scope	24
4.3 Design Loads	24
4.3.1 General	24
4.3.2 Soil and Water Loads	24
4.3.3 Surcharge Loads	25
4.3.4 Operational Loads	25
4.3.5 Dynamic Loads	25
4.3.6 Restraint Loads	25

	<u>Page</u>
4.4 Design Criteria	26
4.4.1 General	26
4.4.2 Sloped Excavations	26
4.4.3 Braced Excavations	27
4.5 Information on Accepted Engineering Practice	30
4.5.1 General	30
4.5.2 References	30
4.5.3 Summary of Information	30
5. COMMENTARY ON RECOMMENDED STANDARD PRACTICE	35
5.1 Sloped Excavations (Sec. 3.2)	35
5.2 Strength of Shoring Systems (Sec. 3.3.1)	36
5.3 Loads Acting on Shoring Systems (Sec. 3.3.2)	36
5.4 Soil Classification (Sec. 3.4)	51
5.5 Spaced Sheet piling (Sec. 3.5)	51
5.6 Recommended Special Provisions (Sec. 3.6)	51
6. REFERENCES	53
7. ACKNOWLEDGMENT	55
APPENDIX A - Timber Shoring	57

LIST OF FIGURES

	<u>Page</u>
Figure 1 Explanation of Symbols	xi
Figure 2 Components of Shoring Systems	xv
Figure 2.1 Effect of Foundation Loads on Shoring	5
Figure 3.1 Allowable Configurations of Sloped Excavations	9
Figure 3.2 Loads Acting on Shoring Systems	12
Figure 3.3 Loads Tributary to Members of the Shoring System	13
Figure 5.1 Symbols Used in Derivation of the Equation for the Sloped Backfill Effects	39
Figure 5.2 Simplified Expressions for R_s	41
Figure 5.3 Relationship Between R_s , ϕ , δ and β	42
Figure 5.4 Comparison of Proposed Equation for R_s with NAVFAC Criteria	43
Figure 5.5 Effects of Heavy Construction Equipment	45
Figure 5.6 Dimensions Used in the Derivation of Simplified Expressions for Heavy Equipment Effects	47
Figure 5.7 Effects of m on σ_h	48

LIST OF TABLES

		<u>Page</u>
Table 3.1	Simplified Classification System	16
Table 3.2	Soil Classes in Matrix Classification System	17
Table 3.3	Minimum Acceptable Stability Requirements for the Matrix Classification System	18
Table 3.4	Maximum Center to Center Spacing (in ft) of Spaced Sheeting for the Simplified Soil Classification System .	19
Table 3.5	Maximum Center to Center Spacing (in ft) of Spaced Sheeting for the Matrix Classification System	20
Table 4.1	Typical Values of Unit Weight of Soils [15]	32
Table 4.2	Relationship Between Properties of Cohesionless Soil and Standard Penetration Test Results [19]	32
Table 4.3	Properties of Cohesive Soil and Standard Penetration Test Results (Goldberg, et al., 1976) [9]	33
Table A.1	Allowable Unit Stresses in psi for Hardwood Trenching Lumber	58
Table A.2	Typical Minimum Sizes of Timber Skip Shoring (inches) ...	60
Table A.3	Typical Minimum Sizes of Timber Shoring of Trenches	61
Table A.4	Adjustment of Strut Size for Trench Width	62
Table A.5	Analysis of Table A.2	64
Table A.6	Analysis of Table A.3	64
Table A.7	Timber Skip Shoring Sizes in Accordance with Standard Practice	66
Table A.8	Timber Shoring Strut Sizes in Accordance with Standard Practice	67
Table A.9	Timber Shoring Wale Sizes in Accordance with Standard Practice	68

LIST OF SYMBOLS

- B - Width of excavation
- c - Cohesion (undrained shear strength) of material in bank, lb/ft²
- c_b - Undrained shear strength of material below bottom of excavation, lb/ft².
- D_r - relative density of soil
- h/v - Slope (horizontal over vertical)
- H - Depth of Excavation, in feet.
- H_e - Equivalent depth for sloping backfill in ft
- H_q - Surcharge converted to equivalent soil depth in ft
- k_a - Coefficient of active earth pressure, as defined by pertinent equations listed.
- m - Coefficient in lateral force equation as defined by Peck (1969).
- N = $\gamma H/c$ - Stability number, based on shear strength of material in the bank.
- N_b = $\gamma H/c_b$ - Stability number, based on shear strength of material below bottom of excavation and weight of material in bank.
- \bar{N} - Blowcount in standard penetration test using traditional U.S. methods (rope and cathead) in blows per foot.
- p - Uniformly distributed lateral soil pressure in lb/ft².
- p_q - Uniformly distributed lateral soil pressure caused by equipment load in lb/ft².
- q - lineload parallel to trench in lb/ft.
- S - Load capacity in lb
- \bar{S} - Average strength (average failure load corrected for load duration, if applicable) in lb
- v - Coefficient of strength variation, corrected if necessary for sample size.

- W - total downward force exerted by the weight of heavy equipment in lb.
- w_e - Equivalent weight effect of soil in lb/ft^3 .
- x - distance from edge of excavation in ft
- R_s - ratio of k_a for sloping backfill to k_a for horizontal backfill
- α - Angle between back of retaining structure (facing the soil) and the horizontal, in degrees (see figure 1).
- β - Angle between surface of sloping backfill and the horizontal in degrees (see figure 1).
- γ - Unit weight of soil (in natural condition or as assumed for worst case) in lb/ft^3 .
- γ_{sat} - Unit weight of saturated soil, in lb/ft^3 .
- γ_{sub} - Unit weight of submerged in lb/ft^3 .
- γ_w - Unit weight of water in lb/ft^3 .
- δ - Angle of friction between retaining structure and retained backfill in degrees.
- σ_h - horizontal pressure against rigid retaining wall caused by line-load parallel to trench in lb/ft^2
- σ_{ha} - average horizontal pressure against rigid retaining wall caused by lineload parallel to trench in lb/ft^2
- ϕ - Angle of shearing resistance (internal friction) of soil, in degrees.

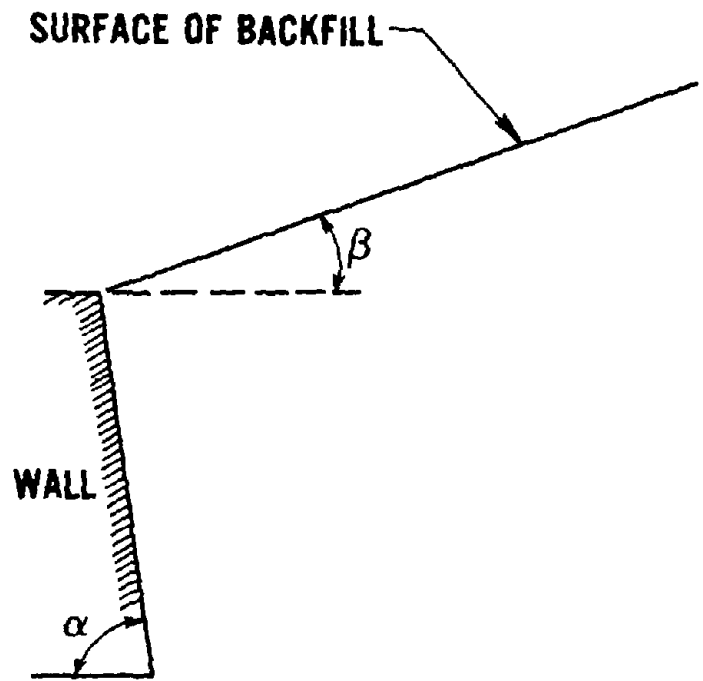

Figure 1. Explanation of Symbols

SI CONVERSION UNITS

In view of the present accepted practice for building technology in this country, common U.S. units of measurement were used throughout the report. In recognition of the position of the United States as a signatory to the General Conference on Weights and Measures, which gave official status to the International System of Units (SI) in 1960, the table below is presented to facilitate conversion to SI units. Readers interested in making further use of the coherent system of SI units are referred to: NBS SP 330, 1972 Edition, The International System of Units; and ASTM E380-76, Standard for Metric Practice.

Table of Conversion Factors to SI Units

<u>To Convert From</u>	<u>To</u>	<u>Multiply By</u>
inch	millimeter	25.4*
inch	meter	2.54* . 10 ⁻²
foot	meter	3.048* . 10 ⁻¹
lb (force)	newton	4.4482
lb (mass)	kilogram	0.4536
lb/in ²	pascal	6.8947 x 10 ³
lb/ft ²	pascal	47.880
ton/ft ²	pascal	95.760 x 10 ³
lb/ft ³ (mass)	kg/m ³	16.018
lb/ft ³ (equivalent force)	N/m ³	157.14

* Exact value, others are rounded to five digits.

DEFINITIONS

Acceptable Practice is practice which meets the minimum requirements recommended in this report.

Allowable Working Stresses are stresses which should not be exceeded under the most critical combination of working loads.

Average Strength is the average failure load corrected for effects of load duration.

Design Criteria are design rules which, if followed, would reduce the risk of occurrence of design limit states to acceptable levels.

Design Limit States are failure modes which endanger workers in, or adjacent to, excavations.

Design Loads are loads used for the design of shoring systems or the determination of slope stability. Design loads may be working loads or ultimate loads.

Engineer is a registered professional engineer.

Fractured Rock is rock which could spall or crumble when excavated with vertical slopes. In general, rock with a pattern of fractures or joints, which are, on the average, closer than 1 ft apart should be considered fractured. Rock is not considered fractured when rock slopes are secured against mass movement and spalling by rock bolts, netting, and other means approved by an engineer.

Load Capacity is a measure of strength defined in Section 3.3.1(2).

Long Term Excavations are excavations which are open for more than 24 hours.

Safety Factor is the ratio of load capacity to the effect of the most critical combination of working loads. In the case of excavation stability, the safety factor is the ratio of resisting forces to driving forces. For excavation slope stability the safety factor can be taken as the ratio of critical height to actual height.

Safety Margin is any measure of excess strength over that required to resist the working loads.

Shoring Systems are structural systems supporting the bank of an excavation. The components of shoring systems are defined in Figure 2.

Short Term Excavations are excavations which are open for 24 hours or less.

Short Term Strength Properties of Soils are the strength properties of the soil adjacent to the excavation during a 24 hour period of exposure. Some of this strength can be lost with the passage of time by such effects as desiccation and lateral expansion. A typical short term strength property is apparent cohesion in moist sands. In some instance there may also be an increase in strength with time (for instance drained vs. undrained strength).

Skeleton Sheeting is spaced sheeting in which the sheeting members (upright or horizontal) are supported by wales (see figure 2).

Skip Shoring is spaced sheeting in which the sheeting members are directly supported by struts.

Standard Practice is the trenching and shoring practice recommended in Section 3 of this report.

Ultimate Loads are working loads multiplied by the following factors:

- 1.7 for long term excavations
- 1.3 for short term excavations

Working Loads are loads which should reasonably be anticipated and which must be resisted with appropriate safety margins. All loads defined in the Standard Practice and the Engineering Guidelines are working loads, unless otherwise noted.

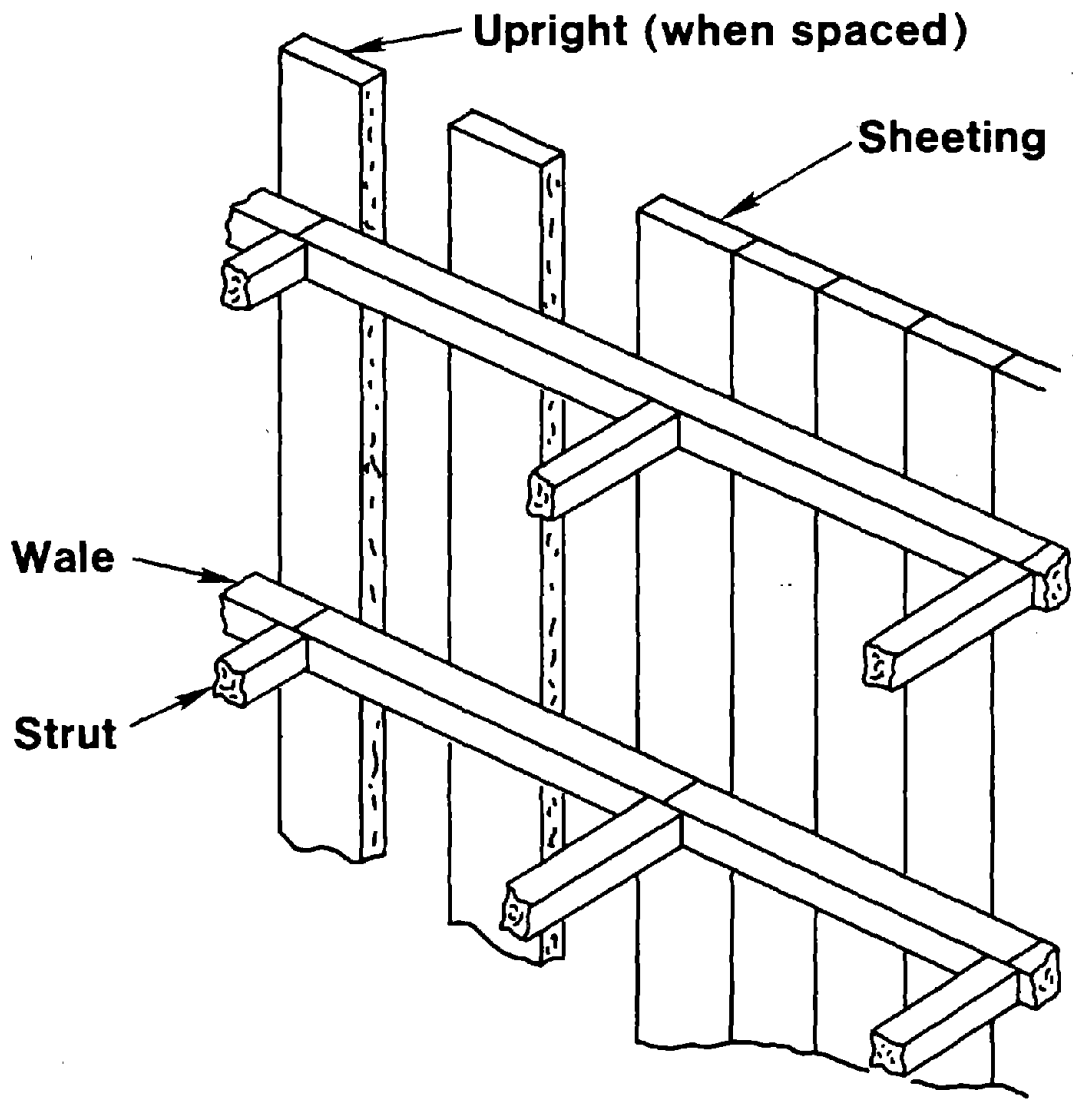

Figure 2. Components of Shoring Systems

FACING PAGE: *Utility trench with hydraulic shoring. Typically, work in such trenches proceeds rapidly and decisions on shoring are made by the construction foreman. (Courtesy, Big Red Safety and Production, Inc., Newark, California).*



1. INTRODUCTION

One of the most important conclusions that can be drawn from an NBS field study of present trenching practice [10, 17] as well as from recommendations made in an August 1978 Federal workshop on this topic [16] is that it is, in many instances, not practical to require that a professional engineer design the shoring or determine the steepest allowable slopes for utility trenches or shallow excavations. Reasons for this conclusion are the fast pace at which this work typically proceeds, the frequently rapidly changing soil conditions which sometimes require instantaneous decisions from the work supervisor, and the typical chain of command at the job site which would not permit an engineer to intervene rapidly enough to effect necessary changes in shoring or sideslopes. Thus, it is necessary to have standards and provisions which can be understood and implemented by the supervisory personnel in the field.

The most important element of any such standard is the soil classification systems which provides the means of relating site conditions to required shoring or steepest permissible sideslopes. Because of the importance of the soil classification systems, two potential approaches are recommended for consideration. The approaches and their advantages and disadvantages are discussed in detail in a report on soil classification [21]. One of the two approaches, but not both, should be considered for inclusion in a future trenching standard. The choice should be made after careful study and deliberation by all the parties involved (contractors, labor unions, engineers and government officials). In accordance with the two alternate soil classification systems, two alternate sets of provisions are recommended for consideration wherever the provisions are tied to the soil classification systems.

The recommended provisions provide two options: Use of a recommended standard practice, or design by an engineer. The standard practice can be used by supervisory personnel in the field to select shoring and determine maximum allowable slopes. The shoring from which the selection is made should be designed by an engineer for pre-determined conditions of use.

The recommended soil classification systems are also correlated with traditional timber shoring practice. Even though NBS analysis of timber shoring as presently used leads to the conclusion that it could not resist the design soil pressures recommended in this report with safety margins consistent with present engineering practice, the NBS study could find no field evidence that properly installed traditional timber shoring is unsafe. There are two possible reasons for this paradox: (1) Allowable stresses presently used in timber design may incorporate safety margins against failure larger than those assumed in the analysis (2) In absence of significant data on forces acting on shallow-trench bracing the recommended design lateral forces are conservatively high. The timber shoring practice is discussed in Appendix A. "Strength-equivalency" to traditional timber shoring members should not be accepted as proof of adequacy for other shoring systems which should be designed in accordance with Section 4.

"Acceptable practice" is defined in Section 2; Section 3 contains the recommended standard practice; recommended guidelines for the design of shoring systems and sloped excavations by engineers are given in Section 4; Section 5 is a commentary on the recommended standard practice; timber shoring practice is discussed in Appendix A.

The acceptable practice recommended in this report serves the purpose of protecting workers against trench cave-ins. It may not prevent damage to adjacent properties by excessive settlements.

FACING PAGE: *Typical timber shoring. A hydraulic shore is used to insert the struts.*

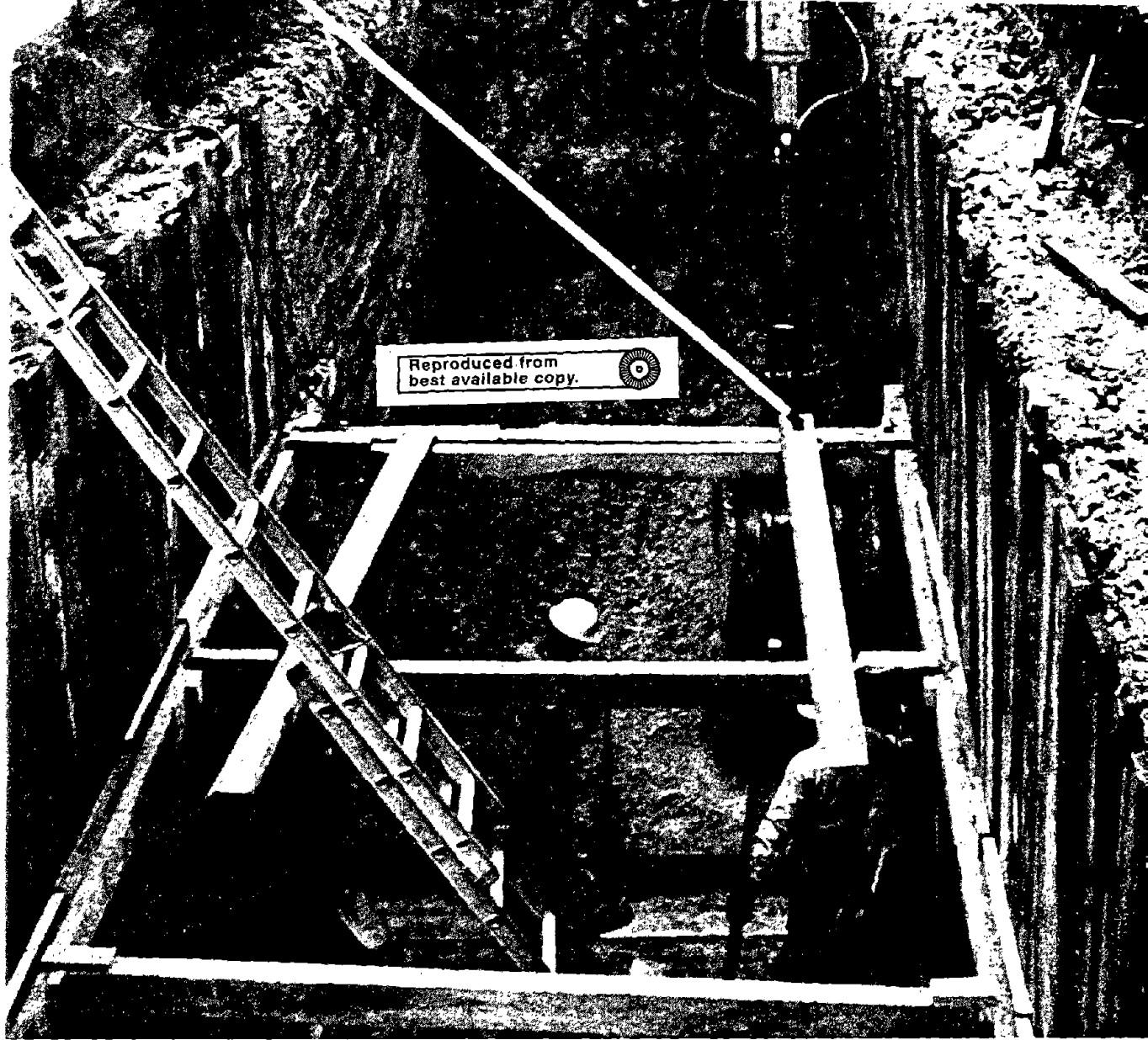

2. ACCEPTABLE PRACTICE

"Acceptable Practice" is defined as practice that meets the minimum requirements recommended herein. Compliance with these minimum requirements, whether by consulting an engineer or by following recommended standard practices, insures in most instances adequate protection of workers against cave-ins. However, soil is not a man-made material and its characteristics are not as predictable as those of common building materials. Thus the contractor who is doing the work has the responsibility to ascertain if there are local site conditions which present special hazards.

For all excavations deeper than 20 feet (except as noted herein) the adequacy of shoring systems and the stability of sideslopes should be determined by an engineer in accordance with the guidelines in Section 4 of this report. An engineer should also be consulted whenever the bottom of a building foundation adjacent to an excavation extends into the

zone between imaginary sideslopes rising at a slope of 1 horizontal: 1 vertical from the outer edges of the bottom of the excavation (see Figure 2.1).

The shoring or sideslopes of excavations deeper than 5 ft and less than 20 ft deep (except as noted herein) should be deemed acceptable if they meet either one of the following conditions: (1) they comply with the standard practice recommended in Section 3 of this report; or (2) an engineer determines that they are adequate in accordance with the guidelines in Section 4 of this report.

Excavations less than 5 ft deep and all excavations in unfractured rock regardless of depth should be exempt from shoring and sloping requirements. The shoring and sloping requirements should also not apply whenever it can be demonstrated beyond reasonable doubt that the cave in of an excavation would not pose a danger to workers, other persons, or adjacent equipment and property. All other excavations should be sloped or shored in accordance with the recommended acceptable practice.

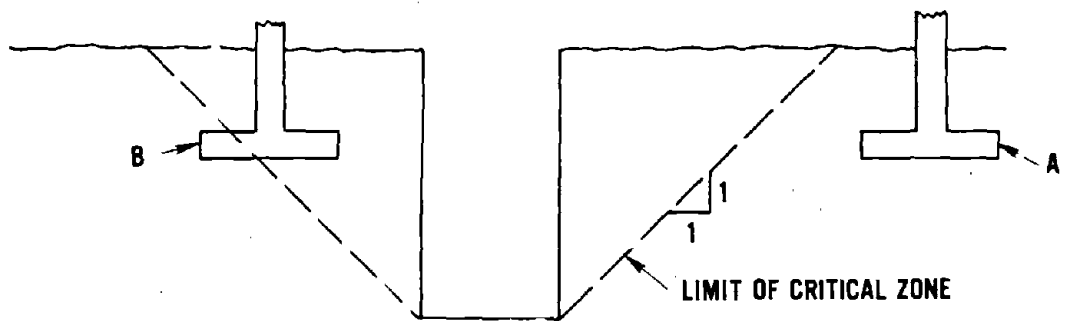

FOOTING "A": STANDARD PRACTICE CAN BE FOLLOWED

FOOTING B: AN ENGINEER SHOULD BE CONSULTED

Figure 2.1 Effect of Foundation Loads on Shoring

FACING PAGE: *Ship shoring in stiff clay. Fissures could cause failure between uprights.*

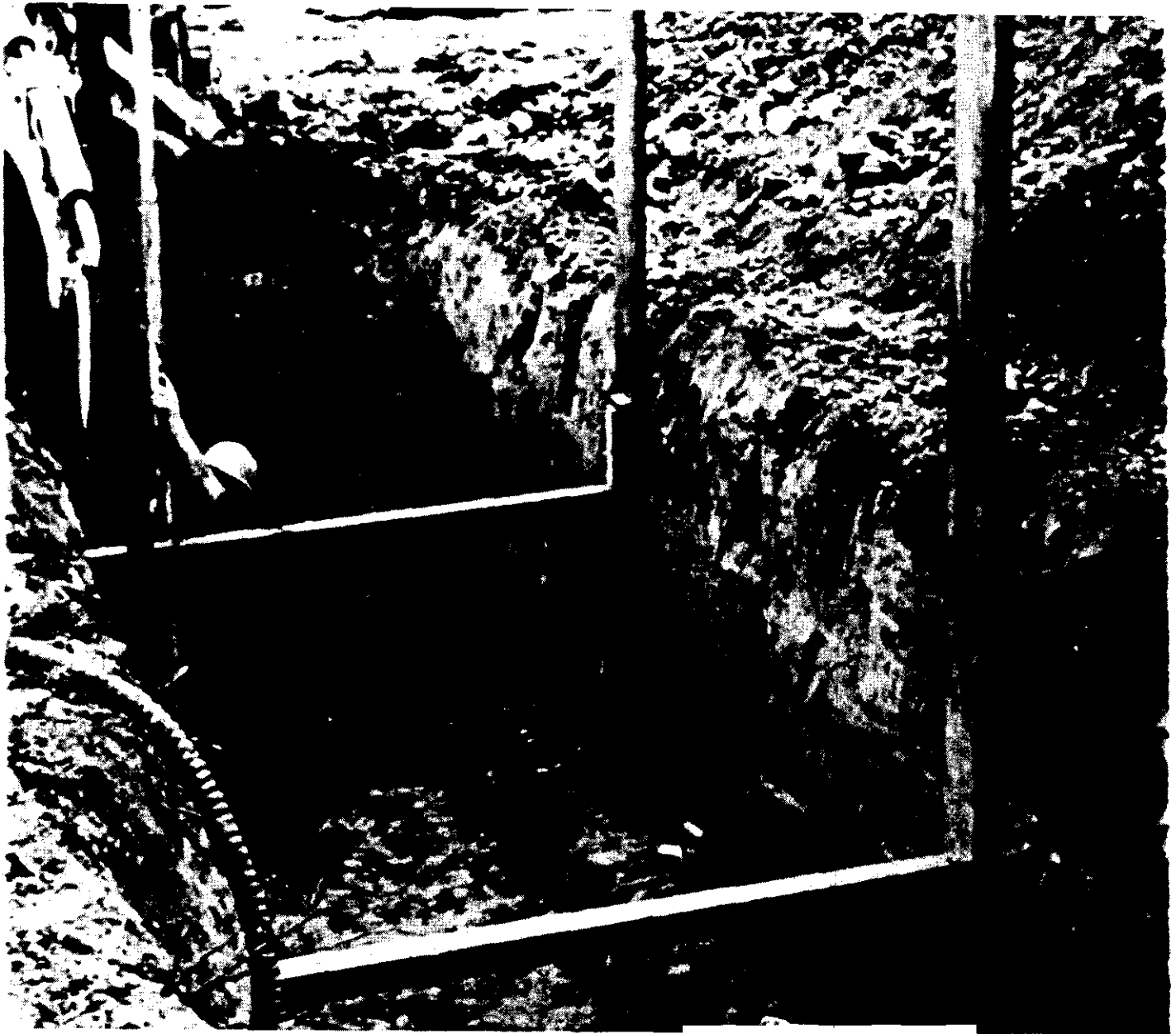

Reproduced from
best available copy.



3. RECOMMENDED STANDARD PRACTICE

3.1 SCOPE

The recommended standard practice applies to all excavations deeper than 5 feet and less than 20 feet deep except those in unfractured rock. Whenever a distinction is drawn between long term and short term excavations, the definition of long term and short term excavations given in this report applies (24 hours is the division point). "Excavations" include, but are not limited to, utility trenches.

3.2 SLOPED EXCAVATIONS

Sloped excavations should not have sideslopes steeper than those stipulated in Tables 3.1 or 3.3^{2/}. If there is any indication of general or local instability slopes should be cut back to be at least 1/4 hor. :1 vert. flatter than the "stable" slopes (the "stable slope" is the slope which will remain stable for the duration of the excavation). The slope configuration of short term excavations can be modified as shown in Figure 3.1.

3.3 SHORED EXCAVATIONS

3.3.1 Strength of Shoring Systems^{3/}

Shoring systems should be designed to resist the working loads stipulated in Section 3.3.2. The term "designed to resist" should be interpreted as follows [(1) or (2)]:

(1) The following stresses are not exceeded: 1.33 times the allowable working stresses in short term excavations; 1 times the allowable working stresses in long term excavations. "Allowable Working Stresses" are defined as the "allowable stresses" stipulated in applicable standards [1, 2, 3, 12] in conjunction with traditional "working stress" design (using unfactored loads and safety margins). For timber shoring which is left in place (not re-used for other excavations) allowable working stresses can be adjusted for load duration as follows: 2-day duration for short term excavations; 6-month duration for long term excavations. Allowable stresses for hardwood timber are recommended in Appendix A. Allowable stresses for softwood timber should be in accordance with Ref. [12]; or (2) The system has adequate load capacity to resist the following factored loads: 1.3 times the working loads stipulated in Section 3.3.2 in short term excavations. 1.7 times the working loads stipulated in Section 3.3.2 in long term excavations. "Load capacity" is defined as one of the following:

(a) "Required strength" as defined for reinforced concrete members in ACI 318-77 [2];

or (b) "maximum strength" as defined for steel members in Part 2 of the AISC Specifications [3];

or (c) $S = \bar{S} (1 - 2v)$, where:

^{2/} Either one or the other applies, depending on the soil classification system adopted (see Section 3.4).

^{3/} Consideration could be given to exemption of conventional timber shoring systems from the minimum strength requirements (see Appendix A).

$\frac{h}{v}$ = Steepest allowable sideslope

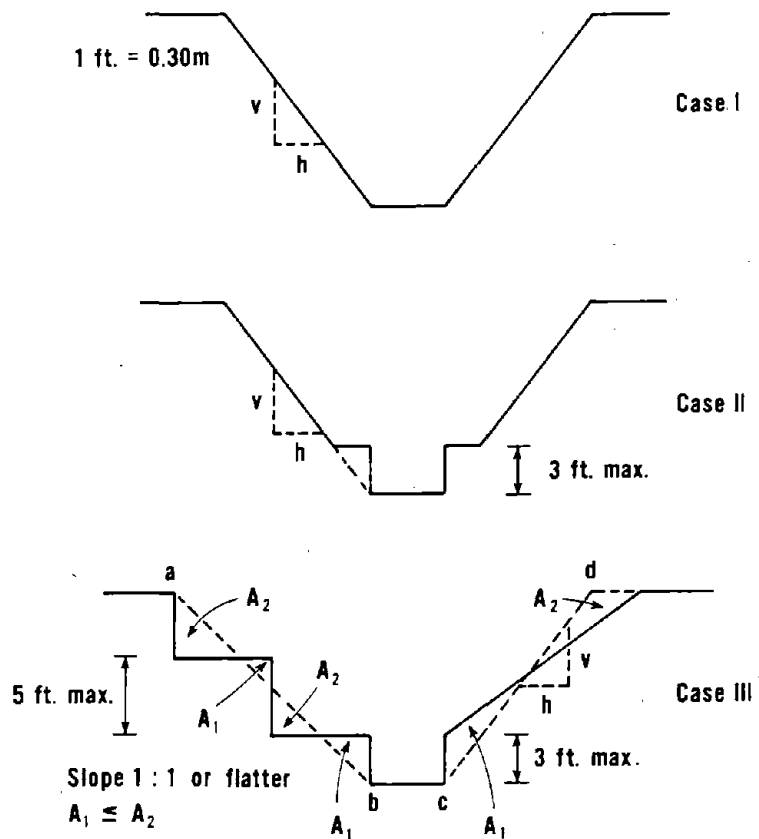

Case I - Ordinary slope

Case II - Compound slope with bench no more than 3 ft. high

Case III - Configuration must meet following criteria:

1. No vertical bank to exceed 5 ft., the vertical bank adjacent to the work area not to exceed 3 ft.
2. Imaginary slopes ab and cd not to exceed max. allowable. If steps are used (left side of Case III) imaginary slope ab not to exceed 1 : 1
3. Excavated area equal to or greater than area within $abcd$

Figure 3.1 Allowable Configurations of Sloped Excavations

S = load capacity

\bar{S} = average strength (failure load corrected for load duration if applicable)

v = coefficient of variation of strength, corrected if necessary for sample size.

3.3.2 Loads Acting on Shoring Systems

(1) General

All loads given in this section are "working loads". They are loads which should reasonably be anticipated and which must be resisted with appropriate safety margins.

(2) Operational Loads

The following minimum load should be used for the design of all struts (cross braces): A gravity load of 240 pounds distributed over any 1 foot long portion of the strut.

In addition, trench boxes and other shoring systems installed by methods which do not assure that the sheeting bears tightly against the excavated bank before workers enter the trench (there may be an open space between the bank and the sheeting) should withstand without failure an impact energy of 240 ft-lb applied at any point against the sheeting side facing the bank (inward). In shoring systems whose struts are pre-loaded to exert a force of 500 lb or more against the excavated bank, the sheeting is considered to bear tightly against the bank.

(3) Lateral Soil Pressures

Lateral soil pressure per unit surface area of shoring should be calculated by eq (3.1), eq (3.2) or eq (3.3), whichever results in the largest lateral pressure

$$p = w_e (H + 2) \dots \dots \dots \text{eq (3.1)}$$

$$p = w_e H_e \dots \dots \dots \text{eq (3.2)}$$

$$p = w_e (H + H_q) + p_q \dots \dots \dots \text{eq (3.3)}$$

p = a uniformly distributed lateral soil pressure in lb/ft².

w_e = equivalent weight effect on lb/ft³ as stipulated in Tables 3.1 or 3.3.

H = depth of excavation from top of supported bank to bottom of excavation in feet.

H_e = equivalent height for sloping backfill in ft as defined in Figure 3.2

H_q = height of surcharge (spoil or stored material converted to equivalent soil depth) in ft.

p_q = lateral pressure caused by equipment or traffic loads in lb/ft^2 as defined in figure 3.2

Equation (3.1) applies to excavations in level ground (not steeper than 3 horizontal: 1 vertical) and has an allowance for surcharge which is adequate for most ordinary conditions (2 feet are added to the height H).

Equation (3.2) applies whenever the ground or the retained backfill slopes upward at an angle steeper than 3 horizontal: 1 vertical (sloping backfill can be disregarded when the slope is less than 3 horizontal: 1 vertical).

Equation (3.3) applies when very heavy equipment is used (producing lateral pressures greater than those caused by the 2 ft surcharge in eq (3.1)). The three cases in eq (3.1), eq (3.2), and eq (3.3) are illustrated in Figure 3.2.

(4) Loads Tributary to Members of the Shoring System

The following portion of the lateral loads caused by the uniform lateral soil pressure p shall be assumed to act on members of the shoring system: 100 percent of the tributary load shall be assumed to act on all struts, 80 percent of the tributary load shall be assumed to act on wales (members directly supported by struts shall be designed as wales), 67 percent of the tributary load shall be assumed to act on sheeting. Tributary load shall be calculated in accordance with Figure 3.3.

3.3.3 Rating of Shoring Systems

Components or subassemblies of shoring systems, or fully assembled self-contained shoring systems, should be rated and subsequently used to resist working loads equal to, or smaller than, those for which they are rated to be adequate.

Rating may be accomplished as follows:

Struts may be rated for the compressive working loads they are allowed to resist. If struts are extendable, the rating should consider length effects on load capacity. Rating of struts should include consideration of the 240 pound vertical downward load stipulated in Section 3.3.2 (2).

Wales supported at given length intervals could be rated for allowable load per linear foot of wale. For strut-wale assemblies the wale should be designed to resist moments and shears not less than 80 per-

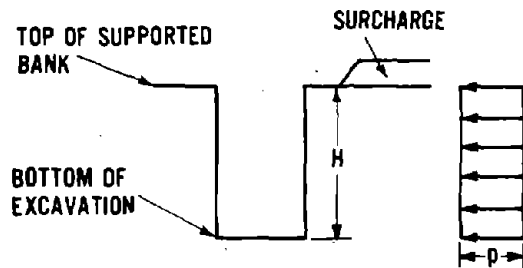

(a) AVERAGE CONDITION, TERRAIN NOT
STEEPER THAN 3 hor : 1 vert

$$p = w_e(H+2) \dots \text{eq (1)}$$

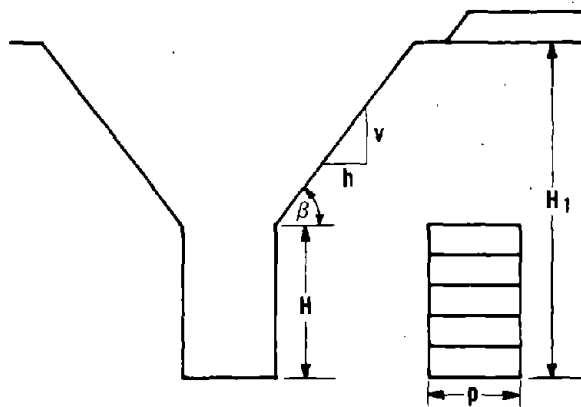

(b) SLOPED BACKFILL

$$p = w_e H_e \dots \text{eq (2)}$$

$$H_e = H(1 + 2\frac{v}{h}) \approx H(1 + 0.04\beta)$$

$$\text{or } H_e = H_1 + 2$$

WHICHEVER IS LESS

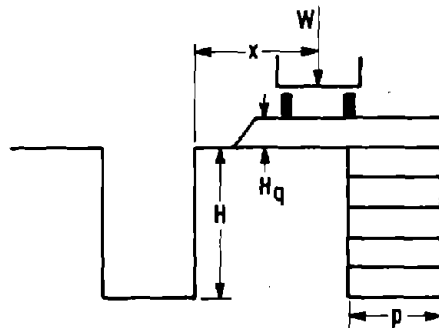

(c) HEAVY SURCHARGE

$$p = w_e(H+H_q) + p_q$$

$$p_q = \frac{W}{H(\ell+x)} (1 - 0.6\frac{x}{H}) \leq \frac{0.8W}{H(\ell+x)}$$

p_q CAN BE DISREGARDED WHEN $x \geq H$

ℓ = LENGTH OF EQUIPMENT OR
LINELOAD IN THE DIRECTION OF
THE TRENCH

W = TOTAL FORCE EXERTED BY WEIGHT
OF EQUIPMENT OR LINE LOAD

NOTE: If wheel spacing is wide, p_q should be also checked for x = distance from edge of excavation to closest wheel and W = weight supported by closest wheel.

Figure 3.2 Loads Acting on Shoring Systems

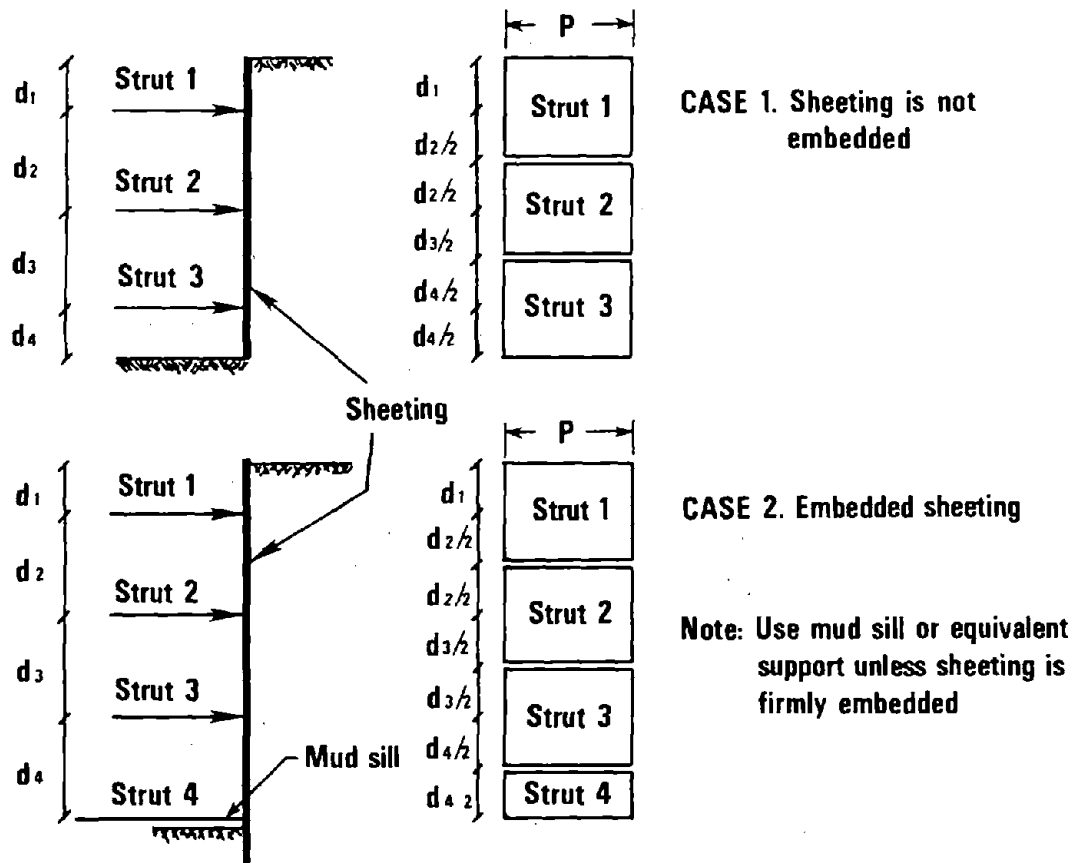

Figure 3.3 Loads Tributary to Members of the Shoring System

cent of those resulting from a load per linear length equal to the sum of the tributary allowable strut loads divided by the length of the wale.

Self-contained repetitively-used shoring systems such as trench boxes, hydraulic shoring systems or pre-fabricated strut-wale assemblies could be rated either for allowable working loads (in lb per square foot of trench wall), or for pre-determined conditions of use. Rating for conditions of use would include designation of maximum allowable depth (or equivalent depth if the backfill is sloped) for given soil types. Thus a trench box could be rated for use in a 20 foot depth in Type B (Class II) soil (see Tables 3.1 and 3.3) or, alternately, for an allowable working load of 880 lb/ft².

Rating Procedures:

The rating should be based on the professional opinion of an engineer and marked on the component or assembly. It could be accomplished by engineering analysis or testing. In addition to the loads stipulated in Section 3.3.2 the engineer should consider loads resulting from installation and construction procedures.

Repetitively used assemblies or components should be kept in good repair. This could be accomplished by limiting the validity of the rating to a 1 year period, and renewing the rating after inspection by an engineer. In this case the rating should have an effective date. Hydraulic shores should be tested at least once a year to 1.25 times their allowable working load, and the load should be maintainable for at least 5 minutes without a pressure drop.

3.3.4 Determination of Load Capacity by Test

If the load capacity of structural components of a shoring system is determined by test, the following minimum requirements are recommended:

1. Strength variability should be considered in accordance with the definition of load capacity.
2. Under no circumstances should the allowable working load of struts in short term excavations exceed 67 percent of the mean failure load or in long term excavations 50 percent of the mean failure load.
3. For struts the test load should be applied with an eccentricity of not less than 1/3 the thickness of the strut with respect to any one of the principal axes (but not simultaneously with respect to both axes), or with the eccentricity producing an end moment equal to the center-span moment caused by a concentrated load of 240 lb times the applicable load factor (3.3.1(2)) applied at the center of the strut, whichever is greater. Load eccentricities should be of the same magnitude and direction on both ends of the strut (single curvature).

4. For wood members the provision of ASTM D2915 [4] should serve as a guideline.
5. Impact load should be applied by a 60 lb sand filled leather bag fabricated in accordance with Section 12.2 of ASTM E72-77 [5]. During the impact test the sheeting should be supported as in actual working conditions. Three successive impact tests should be applied. "Failure" under impact load is defined as any one of the following: rupture of the sheeting or any of its structural supporting members; any structural damage that would lower the load capacity of the shoring below that required; excessive bending which could endanger workers in the trench.

3.4 SOIL CLASSIFICATION

3.4.1 General

Two alternate soil classification systems are recommended: The "Simplified Classification System", and the "Matrix Classification System." One of the two systems should be incorporated into the standard practice.

3.4.2 Simplified Soil Classification System

The Simplified Classification System is shown in Table 3.1. Soils are divided into three types: A, B, and C. For each soil type the "equivalent weight effect", w_e , to be used in eq. (3.1), (3.2) or (3.3) for the calculation of lateral soil pressure, and the maximum permissible side-slope for sloped excavations are stipulated. The notes in the table provide guidance for the selection of the soil type. Identification procedures and tests are further described in Chapter 5 of Reference [21].

3.4.3 Matrix Soil Classification System

The Matrix Classification System is shown in Table 3.2. Soils are divided into four classes (I, II, III, and IV). "Equivalent weight effects" and maximum allowable slope for each soil class are given in Table 3.3. Guidance for the selection of the Soil Class is given in the footnotes to Table 3.2 and identification procedures and tests are further described in Chapter 5 of Reference [21].

3.5 SPACED SHEETING

3.5.1 General

Spaced sheeting can be used only when there is no evidence of spalling or collapse of the unsheeted bank between sheeting members.

Table 3.1 Simplified Classification System

Soil Type	Description	w_e lb/ft ³	Steepest Allowable Slope hor.:vert. ^{b/}	
			Depth 12 ft or less	Depth 12-20 ft
A	Intact Hard	20 ^{a/}	3/4 : 1	1 : 1
B	Medium	40	3/4 : 1 ^{c/}	1 1/2 : 1
C	Submerged or Soft	80	1 1/2 : 1	2 : 1

Note:

1. Intact Hard Soils (Type A) include stiff clays and cohesive or cemented sands and gravels^{d/} (hardpan, till) above the ground water table which have no fissures, weak layers, or inclined layers that dip into the trench. Stiff clays included have an unconfined compressive strength (pocket penetrometer reading)^{e/} $q_u = 1.5$ tsf or more. Intact hard soils subject to vibrations by heavy traffic, pile driving or similar effects are Type B.
2. Medium Soils (Type B) are all soils which are not Type A or C.
3. Soft Soils (Type C) include cohesive soils^{d/} with an unconfined compressive strength (pocket penetrometer reading)^{e/} of 0.5 tsf or less and soils that cannot stand on a slope of 3 hor. : 1 vert. without slumping (muck).
4. Submerged Soils (Type C) are assumed whenever water drains into the trench from the soil forming the bank; or water is retained by tight sheeting; or there is a possibility that the trench may be fully or partially flooded before workers leave it or may be entered by workers within 5 hours after more than half of its depth was flooded and pumped out.
5. Fractured Rock shall be considered Type B when it is dry and Type C when it is submerged. Unfractured rock is exempt from shoring and sloping requirements.
6. Layered Systems (two or more distinctly different soil or rock types or micaceous seams in rock) which dip toward the trench wall with a slope of 4 hor.: 1 vert. or steeper are considered Type C. Layered soils are classified in accordance with the weakest layer.
7. Spaced Shoring Systems (Skeleton sheathing or skip shoring) are permitted in Type A and B cohesive soils with maximum center to center spacing in accordance with Table 3.4

^a In long term excavations use $w_e = 40$ lb/ft³

^b If there is any indication of general or local instability slopes shall be cut back to a slope which is at least 1/4 hor.: 1 vert. flatter than the stable slope.

^c In long term excavation steepest allowable slope should be 1:1

^d Cohesive soils are clays (fine grained) or soils with a high clay content which have cohesive strength. They do not crumble, can be excavated with vertical sideslopes, are plastic (can be molded into various shapes and rolled into threads) when moist and are hard to break up when dry.

^e The pocket penetrometer is a small (vest pocket sized) commercially available device that measures in-situ shear strength of cohesive soils.

Table 3.2 Soil Classes in Matrix Classification System

Soil \ Site Condition	Water in Trench			
	No		Yes	
	Fissures		Fissures	
	No	Yes	No	Yes
Stiff Cohesive ^a	I	II	III	
Medium Cohesive	II	III	III	IV
Granular ^b	II		III	
Soft	IV		IV	

Notes:

1. Water in Trench is assumed whenever water drains into the trench from the soil forming the bank, or water is retained by tight sheeting, or there is a possibility that the trench may become fully or partially flooded before workers leave it, or may be entered by workers within 5 hours after more than half its depth was flooded and pumped out.
2. Vibrations: Soils subject to vibrations by heavy traffic, pile driving or similar effects shall always be assumed fissured.
3. Stiff Cohesive Soils^a include stiff clays and cohesive or cemented sands and gravels (till, hardpan). Stiff clays included have an unconfined compressive strength (pocket penetrometer reading)^{c/} of 1.5 tsf or larger.
4. Medium Cohesive of Soils^a have an unconfined compressive strength (pocket penetrometer reading) between 0.5 and 1.5 tsf.
5. Granular Soils^{b/} are gravels, sands and silts that can stand on a slope steeper than 3 hor.: 1 vert. without spalling or slumping.
6. Fractured Rock shall be treated as granular soil. Unfractured rock is exempt from shoring and sloping requirements.
7. Soft Soils are cohesive soils with an unconfined compressive strength (pocket penetrometer reading)^{c/} of 0.5 tsf or less and soils that can not stand on a slope of 3 hor.: 1 vert. without slumping (muck).
8. Layered Systems (two or more distinctly different soil or rock types, micaceous seams in rock) which dip toward the trench wall with a slope of 4 hor.: 1 vert. or steeper are considered Class IV soils.
9. Disturbed Cohesive Soils (backfill) shall be treated as fissured medium cohesive or soft cohesive soil.
10. Spaced Shoring Systems (skeleton sheathing or skip shoring) are permitted in stiff and medium cohesive soil with maximum center to center spacing in accordance with Table 3.5.

^a Cohesive Soils are clays (fine grained) or soils with a high clay content which have cohesive strength. They do not crumble, can be excavated with vertical sideslopes, are plastic (can be molded into various shapes and rolled into threads) when moist and are hard to break up when dry.

^b Granular Soils have no cohesive strength. They normally cannot be excavated with vertical sideslopes (some moist granular soils will exhibit apparent cohesion and temporarily stand

Table 3.3 Minimum Acceptable Stability Requirements
for the Matrix Classification System

Soil Type	w_e lb/ft ³	Steepest Allowable Slope hor.:vert.	
		Depth 12 ft or less	Depth 12-20 ft
I	20 ^{a/}	1/2 : 1 ^{b/}	1 : 1
II	40	3/4 : 1 ^{c/}	1 1/4 : 1
III	60	1 : 1	1 1/2 : 1
IV	80	1 1/2 : 1	2 : 1

Notes:

1. If there is any indication of general or local instability, slopes shall be cut back to a slope which is at least 1/4 hor. : 1 vert. flatter than the stable slope.
2. In layered soils stability requirements are governed by the weakest layer.

^{a/} In long-term excavations use $w_e = 40$ lb/ft³

^{b/} In long-term excavation steepest allowable slope should be 3/4:1

^{c/} In long-term excavation steepest allowable slope should be 1:1

3.5.2 Strength of Spaced Sheeting^{3/}

1. Struts and Wales: Struts and wales supporting spaced sheeting should be designed to resist the full tributary lateral load (the same load that would be calculated for tight sheeting).
2. Sheeting: Spaced sheeting members should be designed to resist the lateral load tributary to an area equal to the length of the member times the center to center spacing between the sheeting members (this includes the unsheeted portion of the trench wall) as follows:

Sheeting members supported by wales (skeleton sheathings) should be designed to resist 67 percent of the lateral soil pressure "p" [3.3.2.(3)]; sheeting members directly supported by struts (skip shoring) should be designed to resist 80 percent of p.

3.5.3 Maximum Spacing of Spaced Sheeting

The maximum center to center spacing of spaced sheeting for the Simplified Soil Classification and the Matrix Soil Classification, respectively, is given in Tables 3.4 and 3.5.

Table 3.4 Maximum Center to Center Spacing (in ft) of Spaced Sheeting for the Simplified Soil Classification System

Soil Type	Depth, ft	
	5-10	10-15
A	8 (6) ^{a/}	6 (4) ^{a/}
B	3	2

^a Numbers in parentheses are preferred spacings and maximum spacing for long-term excavations.

^{3/} Consideration should be given to exemption of conventional timber shoring from minimum strength requirements.

Table 3.5 Maximum Center to Center Spacing (in ft) of Spaced Sheeting for the Matrix Classification System

Soil Class	Depth, ft	
	5-10	10-15
I	8 (6) ^{a/}	6 (4) ^{a/}
II	3	2
III	3	2

^{a/} Numbers in parentheses are preferred spacings and maximum spacing for long-term excavations.

3.6 RECOMMENDED SPECIAL PROVISIONS

(1) Intersecting Trenches

When two trenches with vertical or steep (not sloped) sidewalls intersect and one trench is shored, the intersecting trench should also be shored to a distance of not less than its depth from the intersection of the two trench walls.

(2) Sloping Backfill

If the slope of the backfill behind the trench shoring exceeds 3 hor. in 1 vert. workers in the trench must be protected against objects rolling or sliding from the sloped backfill. This can be accomplished by projecting the sheeting at least 18 inches above the ground surface or by a specially constructed protective sill.

(3) Excavation Below the Bottom of the Sheeting

Excavation up to 2 ft below the bottom of the sheeting or trenchbox could be permitted in short-term excavations provided that:

1. No soil movement below the bottom of the sheeting is evident; and
2. The forces acting on the bracing system are calculated for the full depth of the excavation, and the sheeting projecting below the lowest wale as well as the lowest wale are designed to resist the forces that would result if the sheeting would be projecting to the bottom of the excavation.

(4) Restriction on Placement of Equipment and Material

Unless special provisions are made to provide support for the resulting loads and protect workers against rolling and sliding objects, construction equipment and excavated and other material should not be placed closer than 2 ft from the edge (top of the bank) of any excavation (spoil piles should preferably be placed no closer than 3 ft from the top of the bank).

FACING PAGE: Large excavation using steel soldier piles, wooden lagging, backties (near top), raker braces (near bottom), and sloped sides where feasible (background). The shoring and sloping used was designed by an engineer after careful soil exploration. (Courtesy, Schnabel Foundation Company, Bethesda, Maryland).



4. ENGINEERING GUIDELINES FOR THE DESIGN OF SHORING SYSTEMS AND OTHER MEANS TO PREVENT MASS MOVEMENT OF SOIL AND ROCK

4.1 GENERAL

These guidelines are for engineers who design shoring systems or determine sideslopes in excavations. The guidelines are not meant to be a standard from which an engineer cannot deviate. Rather, they recommend minimum design loads and safety margins against mass soil and rock movement which are considered appropriate and design limit states which should be considered by engineers. It is recognized that the design of shoring systems, the stability analysis of slopes, and the assessment of soil conditions are not an exact science which can be approached with a set of rigid rules, but rather an art which requires judgment, experience and recognition of unique local conditions. Thus these guidelines can neither be imposed as mandatory rules, nor can a professional engineer forego his responsibility to determine in each instance whether the stated guidelines are adequate.

4.2 SCOPE

The guidelines contain recommended minimum requirements for the protection of workers in excavations against death and injury by mass movement of soil and rock. They do not cover other important parameters which an engineer must consider, such as protection of adjacent structures, utilities and improvements against damaging settlements, or effects of ground water fluctuations on adjacent properties. They also do not cover other safety requirements in excavations which are unrelated to soil and rock movement.

Three methods of preventing soil and rock movement are considered in the guidelines: sloping of the banks of excavations; shoring; and shielding of the work space by protective devices. Other methods could also be used such as soil stabilization by freezing or grouting. The guidelines do not apply to excavations whose collapse does not endanger workers.

4.3 DESIGN LOADS

4.3.1 General

All the design loads listed, but not necessarily only the listed loads, should be considered. Unless specifically stated otherwise in the design criteria, the most critical combination of design loads should be considered. The design loads quantified herein are "working loads" (see definition).

4.3.2 Soil and Water Loads

Loads caused by soil and water pressures should be calculated in accordance with accepted engineering practice and these guidelines.

(1) Loads Caused by Water

Hydrostatic loads, hydrodynamic loads and seepage forces should be considered where applicable. Special attention should be given to the effects of potential groundwater fluctuations, saturation of previously drained deposits, and water penetration into fissures. The following conditions are recommended as the basis for determining critical loads:

For long-term excavations: conditions caused by the 5-year flood.

For short-term excavations: conditions caused by the 1-year flood or alternatively the most severe condition that will not cause interruption of work and evacuation of the workers from the excavation.

(2) Soil Loads

Soil loads should be determined in accordance with the state of the art in geotechnical engineering. Special attention should be given to fissures, planes of weakness and previously excavated soils. The following conditions are recommended as a basis for determining critical loads.

For long-term excavation: Drained as well as undrained conditions should be considered if applicable. Short-term strength characteristics should not be assumed to contribute to stability. Effects of exposure, lateral expansion, desiccation cracks, freezing, erosion, and change in confining pressures should be taken into account.

For short-term excavations: In most instances only undrained conditions should be considered. Short term strength characteristics could be considered, provided that an adequate assessment is made of conditions that could lead to loss of strength.

Further information is provided in Section 4.5

4.3.3 Surcharge Loads

Surcharge loads should be determined on the basis of actual anticipated working conditions. Consideration should be given to: the amount and location of accumulated spoil material; stored construction material; construction equipment; vehicular and human traffic; and foundations adjacent to the excavation.

In no case shall the surcharge load be assumed less than 200 lb/ft^2 distributed over the entire ground surface or the equivalent of an additional 2 ft depth of material excavated on the site (using average unit weight of soil deposits), whichever is more.

4.3.4 Operational Loads

All loads caused by the anticipated excavation work must be considered. These include excavated or construction material supported by portions of the shoring system and workers climbing on the shoring system. The following minimum load should be used for design: A gravity load of 240 lb distributed over any 1 ft long portion of any strut.

4.3.5 Dynamic Loads

Dynamic loads which can reasonably be anticipated as a result of pile driving, blasting, vehicular traffic and construction equipment should be considered.

4.3.6 Restraint Loads

Restraint loads caused by temperature, moisture, or other factors causing dimensional changes in structural members of the shoring system should be considered when applicable. In general, it can be assumed that the empirically based lateral loads calculated in accordance with present engineering practice contain a reasonable allowance for temperature effects on struts.

4.4 DESIGN CRITERIA

4.4.1 General

This section conveys design limit states and design criteria. "Design limit states" are events which constitute a failure to meet safety requirements. "Design criteria" are design rules such as factors of safety to be used which, if followed, should prevent the occurrence of the design limit states. It is conceivable that an engineer could deviate from the design criteria if the occurrence of the design limit states can be prevented by other means.

4.4.2 Sloped Excavations

(1) Design Limit States:

1. Slope stability failure (part or all of the embankment)
2. Sloughing

(2) Design Criteria:

1. Long-term Excavations

- (a) Granular soils (no cohesion):
Slope angle should not exceed angle of shearing resistance.
- (b) Cohesive Soils:
The safety factor against stability failure should be greater than 1.5, unless the excavation is monitored by an engineer using instrumentation and other means. The safety factor should always be greater than 1.3. Suitable surface and subsurface drainage should be provided to prevent stability failures or sloughing induced by seepage or erosion.

Maximum unbraced height of vertical bank:

5 ft for all soils or fractured rock. No limitation for unfractured rock.^{4/}

2. Short-term Excavations

The safety factor against stability failure should exceed 1.3 except that for dry cohesionless soils a slope angle equal to the angle of repose may be maintained. Short-term strength properties could be utilized, provided that there are adequate safeguards against conditions which could cause strength degradation.

^{4/} A geotechnical engineer or engineering geologist should determine whether the rock is unfractured.

Maximum unbraced vertical bank: For intact hard clays the unbraced height could exceed 5 ft provided that an engineer can document that there is substantial empirical evidence that the risk is not excessive. For all other soils, including fractured rock, the maximum unbraced height should not exceed 5 ft. There are no limitations for unfractured rock.

4.4.3 Braced Excavations

(1) Design Limit States

1. Stability failure of the bank
2. Base instability
3. Partial caving or sloughing of the bank between spaced vertical or horizontal supports.
4. Failure of the soil supporting struts, anchors, or soldier piles.
5. Failure of structural components of the shoring system.

(2) Design Criteria

1. Stability of the Bank

A stability failure of the bank is the collapse of all or part of the bank caused by sliding of a soil mass along a failure surface. The failure surface may lie outside the support points of structural members of the shoring systems (supports of raker braces, soil anchors, or the bottom of soldier piles or cantilever sheeting) and thus render the shoring ineffective, or it may be caused by the structural failure of members of the shoring system.

The safety factor against any stability failure of the bank should exceed 1.5.

2. Base Stability

Base instability leads to heaving of the base of the excavation, which in turn can cause dislocation and collapse of the shoring system. The safety factor against base instability should exceed 1.5. Potential effects of uplift resulting from artesian pressure in confined aquifers should be considered. Dewatering should be adequate to prevent piping (quick condition) caused by seepage of groundwater into the base of the excavation. In deep clay deposits, base instability should be considered a problem

whenever N_b exceeds the following values: $N_b > 6$ for trenches where $\frac{H}{B} > 3$; $N_b > 5.14$ for very wide excavations: intermediate values for $0 < \frac{H}{B} \leq 3$.

where $N_b = \gamma H / c_b =$ stability number for base failure.

γ = unit weight of soil, lb/ft³

H = depth of excavation, ft.

B = width of excavation, ft.

c_b = undrained shear strength below excavation base, lb/ft²

3. Soil Stability between Spaced Supports

There is no generally accepted theoretical approach by which the ability of a soil to arch between successive supports can be evaluated or correlated with strength properties of the soil. There is empirical evidence that short-term supports can be spaced up to 8 ft on center in hard clay, very stiff sandy clays or glacial tills, and 2 to 3 ft on center in slightly fissured clays.

Guidance is given in Section 3.5 and should be compared with empirical field evidence.

4. Soil Support for Struts, Anchors or Soldier Piles

A minimum safety factor of 2 is recommended against bearing failures of members of the shoring systems such as raker braces. A safety factor against shear failure of the supporting soil of not less than 1.5 should be used when passive earth pressure is relied upon to support embedded portions of soldier piles and sheeting or deadmen.

All soil anchors should be proof load tested to 1.33 times their working load. If the load capacity of soil anchors is determined by tests, it should be not less than 1.5 times the working load for anchor inclinations of 2 hor. : 1 vert. or flatter, and increase to 2.0 times their working load for inclinations of 1 hor. : 2 vert. When anchor capacity is determined by analysis the safety factor should not be less than 3. Soil anchors subjected to the working load should not show creep when the load is sustained for 15 minutes.

5. Design of Structural Components of the Shoring System

(1) Applicable Standards

Structural members should be designed in accordance with the following standards:

Steel: Specifications for the Design, Fabrication and Erection of Structural Steel Construction, American Institute of Steel Construction, New York, N.Y., Feb. 1969 [3].

Concrete: Building Code Requirements for Reinforced Concrete, (ACI 318-77), American Concrete Institute, Detroit, Michigan, November 1977 [2].

Aluminum: Specifications for Aluminum Structures, The Aluminum Association, New York, N.Y., November 1967 [1].

Wood: National Design Specifications for Wood Construction, National Forest Products Association, June 1977, for soft-wood lumber stresses [12].

Because formally approved allowable working stresses do not exist for most hardwood species, applicable ASTM Standards may be followed in conformance with procedures recognized under the American Lumber Standard, PS70/70. (For allowable stresses refer to Appendix A.)

(2) Allowable Stresses

Allowable stresses should be determined in accordance with the applicable standards. In long-term excavations allowable stresses should not be exceeded under any applicable combination of working loads. In short-term excavations allowable stresses in structural members may be exceeded by up to 33 percent, however, allowable stresses should not be exceeded in connections between structural members.

(3) Ultimate Strength Design

Ultimate strength, rather than working stress design may be used whenever such a procedure is stipulated in the applicable standard or load capacity is determined by test. Ultimate loads should be taken as 1.7 times the working load for long-term excavations and 1.3 times the working load for short-term excavations, and should not exceed the load capacity as defined in Section 3.3.1.

(4) Determination of Load Capacity by Test

Determination of the load capacity of structural components of the shoring system by tests should be in accordance with Section 3.3.4.

4.5 INFORMATION ON ACCEPTED ENGINEERING PRACTICE

4.5.1 General

This section contains a brief summary of information on commonly used engineering practice which is considered to provide adequate protection against the mass movement of soil and rock. The choice of the referenced design approaches should not be interpreted as an endorsement of these approaches over other approaches which are consistent with the present state of the art.

4.5.2 References

The following references provide guidance in the calculation of lateral loads on excavation bracing. Loads calculated in accordance with these references are considered to be working loads: Department of the Navy, 1971 [7]; Goldberg et.al., 1976 [9]; Peck, 1969, [14]; Peck et. al., 1974 [15]; U.S. Steel Co., 1975, [20].

The preceding references contain design approaches which are not necessarily identical. However, all these approaches are widely used and are considered adequately conservative.

4.5.3 Summary of Information

Hereafter is a summary of information derived from references in Section 4.5.2. The suggested pressure envelopes are not intended as an endorsement of one single approach to the problem, but rather as a summary of commonly used approaches.

1. Lateral Pressures

(1) Sands (Peck, 1969)

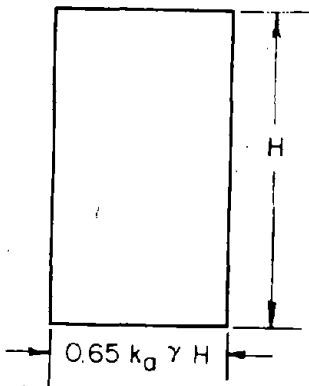

$$k_a = \tan^2 (45 - \phi/2)$$

(2) Soft to Medium Clays, when $N > 6$ (Peck, 1969) (if pressures calculated under (3) using $0.4 \gamma H$ are larger, use (3)).

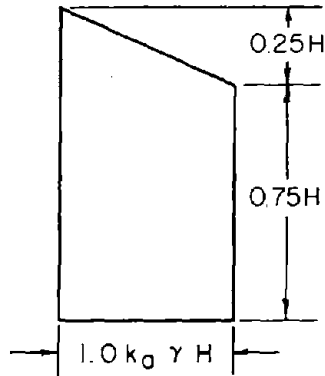

$$N = \gamma H / C$$

$$k_a = 1 - m \frac{4}{N}$$

When cut is underlain by deep, soft, normally consolidated clays: $m = 0.4$
 All other cases: $m = 1.0$

(3) Stiff Clays, whenever $N < 4$. (Peck, 1969) (if $4 < N < 6$ use (2) or (3), whichever gives larger pressures)

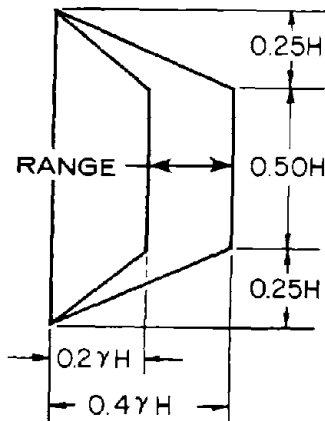

(4) Dense cohesive sands, very stiff sandy clays. (Goldberg et.al., 1976)

Relatively Uniform

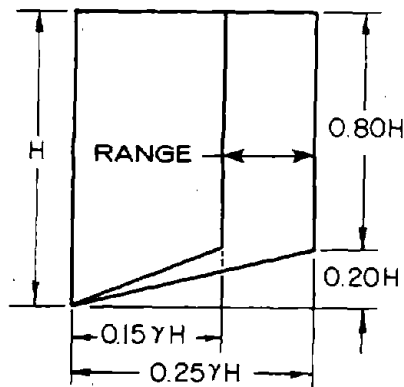

Upper Third of Cut Dominated by Cohesionless Sands

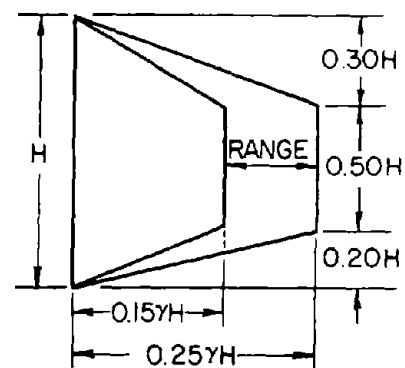

2. Soil Properties

TABLE 4.1. Typical Values of Unit Weight of Soils [15]

Silty or clayey sands & gravel Soil Type	Moist U.W. above W.T., γ (lb/ft ³)	Saturated U.W. Below W.T., γ_{sat} (lb/ft ³)
Poorly graded sand	105-115	115-125
Clean well graded sands	115-125	125-130
Silty or clayey sands	120-130	125-135
Silty or clayey sands & gravel	125-135	130-145
Soft to medium clay	100-115	100-115
Stiff to very stiff clay	110-125	110-125
Organic silt or clay	90-100	90-100

$$\gamma_{\text{sub}} = \gamma_{\text{sat}} - \gamma_w$$

$$\gamma_w = 62.4 \text{ lb/ft}^3$$

TABLE 4.2. Relationship Between Properties of Cohesionless Soil and Standard Penetration Test Results [19]

Soil Type	SPT, \bar{N} blows/ft.	Relative Density $D_r\%$	ϕ (after Peck)	k_a
Very loose sand	<4	0-15	29°	>0.35
Loose sand	4-10	15-35	29°-30°	0.35-0.33
Medium dense sand	10-30	35-65	30°-36°	0.33-0.25
Dense sand	30-50	65-85	36°-41°	0.25-0.21
Very dense sand	>50	85-100	>41°	<0.21

TABLE 4.3 Properties of Cohesive Soil and Standard Penetration Test Results [9]

Clay Consistency	Identification	SPT, \bar{N} blows/ft	Shear Str. lb/ft ²	Comp. Str. lb/ft ²
Very soft	Easily penetrated several inches by fist. Extudes between fingers when squeezed in hand.	<2	250	<500
Soft	Easily penetrated several inches by thumb. Molded by light finger pressure.	2-4	250-500	500-1000
Medium	Can be penetrated several inches by thumb with moderate effort. Molded by strong finger pressure.	4-8	500-1000	1000-2000
Stiff	Readily indented by thumb but penetrated only with great effort. Indented by thumb.	8-15	1000-2000	2000-4000
Very stiff	Readily indented by thumbnail.	15-30	2000-4000	4000-8000
Hard	Indented with difficulty.	>30	>4000	>8000

The correlation between \bar{N} values and soil properties for clays can be regarded as no more than a crude approximation, but for sands it is often reliable enough to permit the use of \bar{N} values in design. Unconfined compression tests or triaxial tests are more reliable for clays. It should also be noted that the value of \bar{N} can be influenced by numerous factors such as: the depth at which the test is made; the location of the water table; presence of boulders in the deposits; irregularities in performing the test; etc. In general, \bar{N} values used here are representative of those obtained by the traditional U.S. (rope and cathead) methods. If other methods are used, a correction for delivered energy is desirable.

FACING PAGE: *A steel trench box is used to protect workers. In present practice the excavation often extends below the bottom of the trench box. (Courtesy, National Utility Contractors Association, Washington, D.C.).*

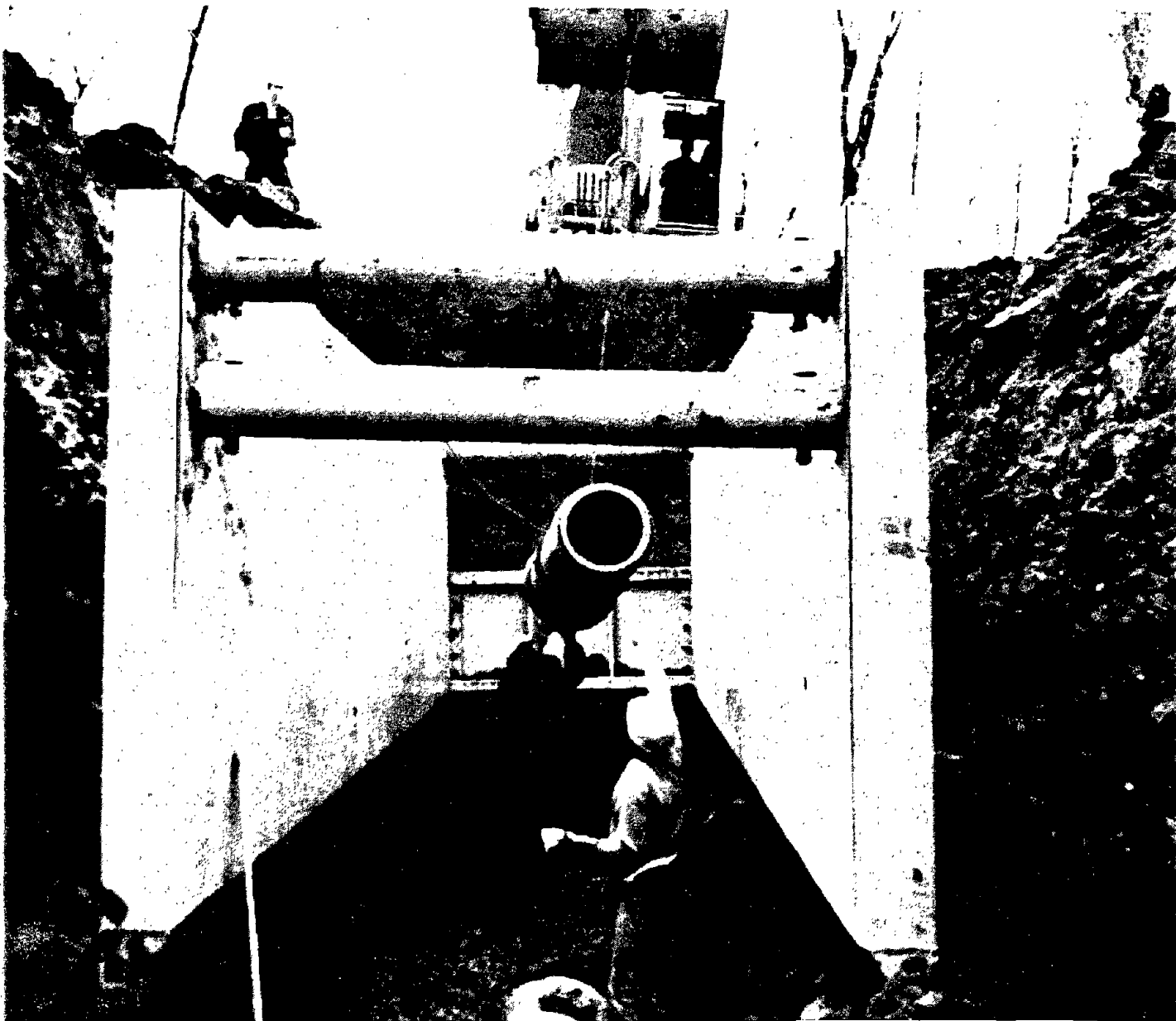

Reproduced from
best available copy.



5. COMMENTARY ON RECOMMENDED STANDARD PRACTICE

5.1 SLOPED EXCAVATIONS (Sec. 3.2)

A commentary on the recommendations in this section is provided in Section 6.2 of Reference [21]. The sloped excavation configurations in Figure 3.1 are suggested in order to give more flexibility to contractors. Vertical sides are frequently required in specifications for pipe bedding. The configuration in Case II would permit contractors to meet such specifications. In Case III any configuration is permitted that would provide overall stability (not necessarily local stability) equivalent to that of the sloped excavation. The 3-ft limitation of the height of the vertical unsupported bank in the vicinity of the work area is provided to minimize the effects of a potential localized collapse and is based on the recommendations of an AFL-CIO Trenching Hazards Identification Task Force

report dated April 25, 1977 which is presented as an appendix to Ref [10]. The 5 ft limitation on the height of any vertical unsupported bank in Case III is consistent with present OSHA regulations.

Steepest allowable slopes are given in Tables 3.1 and 3.3. Steeper slopes are allowed for trenches with depths up to 12 ft. There are two reasons for this recommendation: (1) in cohesive soils a slope which is stable in a shallow excavation may not be stable in a deep excavation; (2) the time of exposure and thus the risk of collapse is less for shallower trenches. For the steeper slopes a distinction is also made between short term and long term excavations, since a steep slope is considered risky when the exposure time is long enough to result in a change in the short-term strength properties of the soil.

5.2 STRENGTH OF SHORING SYSTEMS (Sec. 3.3.1)

A distinction is made between long-term and short-term excavations. For working-stress design allowable stresses in short-term excavations can be increased by 33 percent. For ultimate-load design the load factor for short-term excavations is 1.3 and that for long-term excavations is 1.7. This approximately corresponds to the 33 percent increase allowed for short-term excavations. There are several reasons for decreasing the design loads (or increasing allowable stresses) for short-term excavations:

1. The lateral loads exerted by the retained soil tend to be less for short-term excavation bracing (see Ref. [21]).
2. The time of exposure in short-term excavations is less. This decreases the risk of extreme loading conditions and also the accident risk.
3. Structural members of the shoring system of short-term excavations are stressed for a shorter time.

The definition of "load capacity" is designed to produce safety margins similar to those required in present standards (ACI, AISC, etc.).

5.3 LOADS ACTING ON SHORING SYSTEMS (Sec. 3.3.2)

(1) Operational Loads: [Section 3.3.2(2)]

The 240 lb load on struts is intended to insure that struts would not fall when workers occasionally climb on them. In a study of loads on guard-rails [8] it has been determined that about 95 percent of male workers will have body weights of less than 220 lb (including shoes and safety helmet but not clothing). This weight has been conservatively increased to 240 lb. Larger gravity loads have been proposed by others (Appendix to [10], AFL-CIO report). However, it is suggested that a design for any load other than that caused by the occasional support of workers may lead to misuse and overloading. It is more desirable to prohibit the loading of struts unless they are specifically designed for the loading. The 240

ft-lb impact load specified for sheeting that does not bear tightly (or exert any thrust) against the trench wall is a precaution against the case where an airspace is left between the trench wall and the trench box (or sheeting). Impact load could be generated when the trench wall suddenly collapses and fills the empty gap. It is assumed that in all instances where struts are not pre-loaded to exert a pressure against the trench wall there will be occasional gaps.

(2) Lateral Soil Pressures [Sec. 3.3.2 (3)]

The lateral soil pressure diagrams associated with equations (3.1), (3.2), and (3.3) are for simple soil classification systems (Sec. 3.4) which do not provide enough information to justify the selection of more complex pressure diagrams such as those in Section 4.5.3.

Derivation of Simplified Equations for Pressure Increase Caused by Sloped Backfill.

Equation (3.2)

Eq. (3.2) and the equations for equivalent weight in Figure 3.2 (b):

$$p = w_e H_e$$

$$H_e \approx H(1 + 2v/H) \approx H(1 + 0.04 \beta)$$

are derived hereafter:

The lateral support provided by excavation bracing is not rigid, nor are most soils purely cohesionless. However, the complexity of the case of a soil which has cohesion as well as an angle of shearing resistance, bearing against a flexible support is so great, and there are so many variables that a generalization cannot be made. The assumption made in this derivation, which tends to be conservative and is consistent with present engineering practice, is that the effect of sloping surcharge of a cohesionless soil against a rigid retaining wall can be assumed to give a reasonable indication of the magnitude of the effect of sloping surcharge on the lateral soil pressures on excavation bracing.

The coefficient of active soil pressure for cohesionless soils acting against a rigid retaining wall has been analytically calculated by Coulomb [6] as follows:

$$k_a = \frac{\sin^2 (\alpha + \phi) \cos \delta}{\sin \alpha \sin (\alpha - \delta) \left[1 + \sqrt{\frac{\sin (\phi + \delta) \sin (\phi - \beta)}{\sin (\alpha - \delta) \sin (\alpha + \beta)}} \right]^2} \quad \dots \text{eq(1)}$$

where: k_a = coefficient of active earth pressure

δ = angle of friction between backfill and the wall (is positive if the top of the wall rotates away from the retained soil and negative if the bottom rotate out)

ϕ = angle of shearing resistance of the soil
the other symbols (α , β) are explained in Figure 5.1.

For a vertical wall ($\alpha = 90^\circ$) this reduces to:

$$k_a = \left(\frac{\cos \phi}{1 + \sqrt{\frac{\sin(\phi + \delta) \sin(\phi - \beta)}{\cos \delta \cos \beta}}} \right)^2 \quad \dots \text{eq(2)}$$

if $\beta = 0$ (level backfill)

$$k_a = \left(\frac{\cos \phi}{1 + \sqrt{\frac{\sin(\phi + \delta) \sin \phi}{\cos \delta}}} \right)^2 \quad \dots \text{eq(3)}$$

if $\delta = 0$ and the backfill is level eq (3) reduces to:

$$k_a = \tan^2 (45 - \phi/2)$$

it is assumed that the ratio

$R_s = \frac{k_a (\beta \neq 0)}{k_a (\beta = 0)}$ is a reasonable measure of the pressure increase for

sloping backfill for any given value of δ . If $\alpha = 90^\circ$:

$$R_s = \left[\frac{1 + \sqrt{\frac{\sin(\phi + \delta) \sin \phi}{\cos \delta}}}{1 + \sqrt{\frac{\sin(\phi + \delta) \sin(\phi - \beta)}{\cos \delta \cos \beta}}} \right]^2 \quad \dots \text{eq(4)}$$

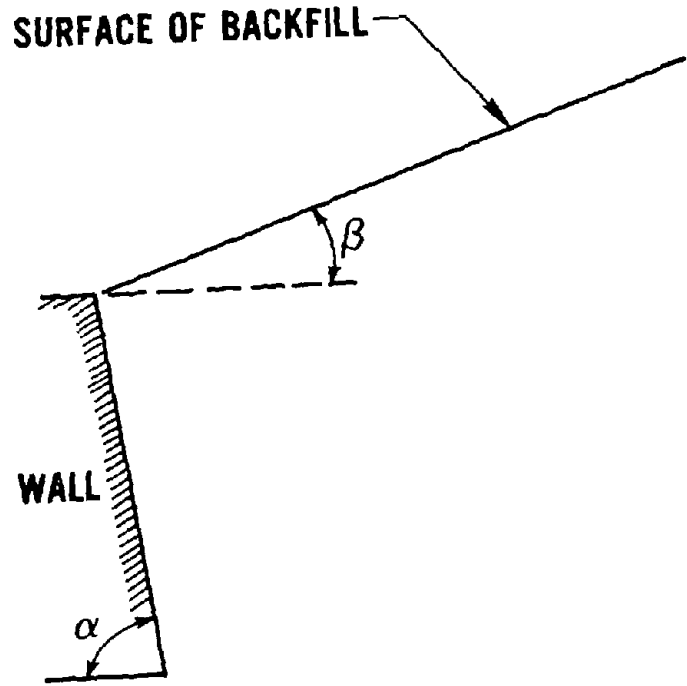

Figure 5.1 Symbols Used in Derivation of the Equation for the Sloped Backfill Effects

if $\delta = 0$ this reduces to:

$$R_s = \left[\frac{1 + \sin \phi}{1 + \sqrt{\frac{\sin \phi \cdot \sin (\phi - \beta)}{\cos \beta}}} \right]^2 \quad \dots \text{eq}(5)$$

For the limiting case where $\beta = \phi$, eq. (5) reduces to:

$$R_s = (1 + \sin \phi)^2 \quad \dots \text{eq}(6)$$

this can be approximated by the following expression in terms of the back-slope angle β in degrees:

$$R_s \approx 1 + 0.04 \beta \quad (\text{if } \beta = \phi) \quad \dots \text{eq}(7)$$

or in terms of backslope gradient (h/v):

$$R_s \approx 1 + 2v/h$$

$$\text{and } H_e = H(1 + 2v/h) \quad \dots \text{eq}(8)$$

Eqs. (6), (7), and (8) are compared in Figure. 5.2.

The case of $\beta = \phi$ is an extreme but not unusual case, since frequently the bottom of a trench is shored while sideslopes are maintained for the remainder of the depth. These sideslopes are likely to approach the steepest stable slope. A similar situation arises on steep sidehills.

In Figure 5.3 a range of R_s values for various values of ϕ and β is shown for the two typical cases of $\delta = -\phi/2$ and $\delta = +\phi/2$. In an actual field situation it is difficult to predict the probable effects of friction between the wall and the soil. Coulomb's assumption on a negative or positive δ is predicated on a rigid-body rotation by the wall relative to the retained soil. In a braced excavation relative movement would mostly occur as a result of wall deformation in flexure. In this case, the direction of relative slippage between wall and soil is not likely to be the same over the full height of the wall. Thus the assumption that $\delta = 0$ seems reasonable. The curve for $\phi = \beta$ and $\delta = 0$ is therefore a conservative upper bound for the effects of sloping backfill in cohesionless soils.

In Figure 5.4, R_s calculated by eq. (6) is compared with curves calculated from Figure 10-9 in NAVFAC Manual DM-7 [7] which is representative of present practice. Note that the curves include clays and that eq (6)

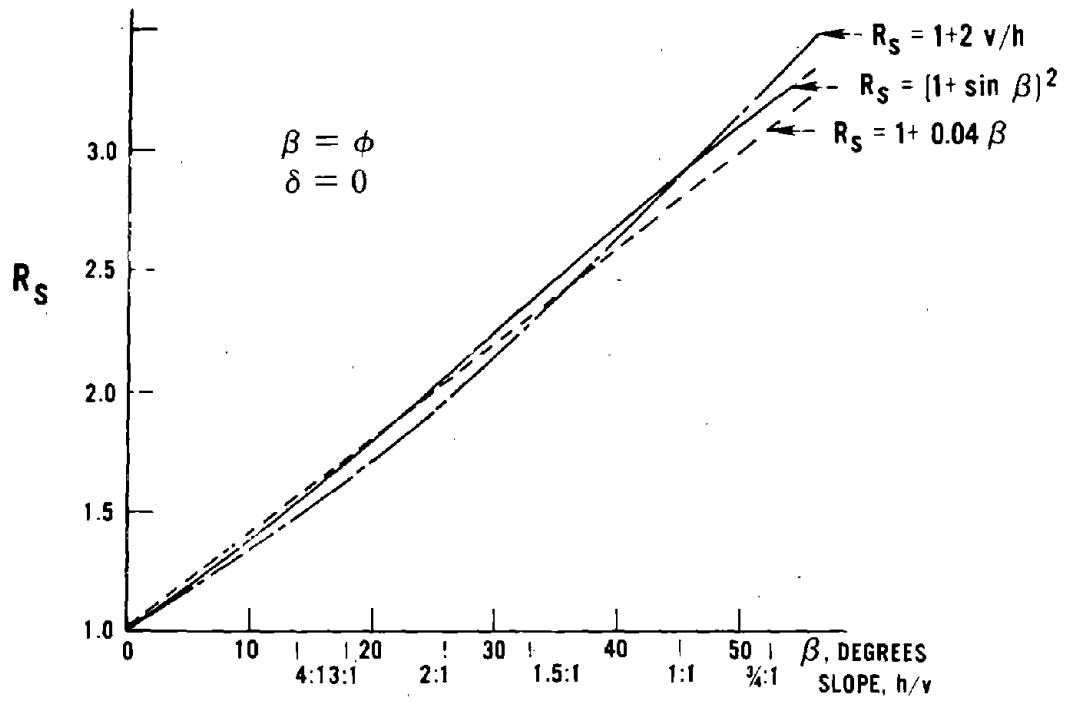

Figure 5.2 Simplified Expressions for R_s

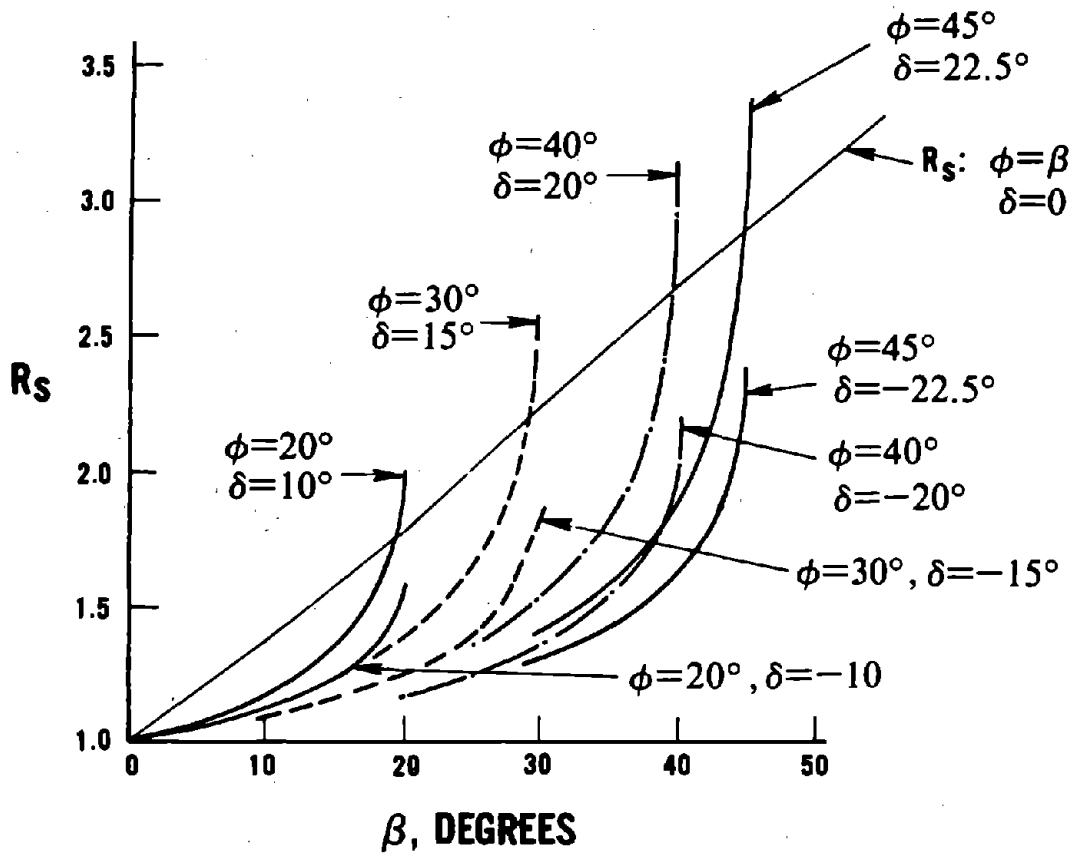

Figure 5.3 Relationship Between R_s , ϕ , δ , and β

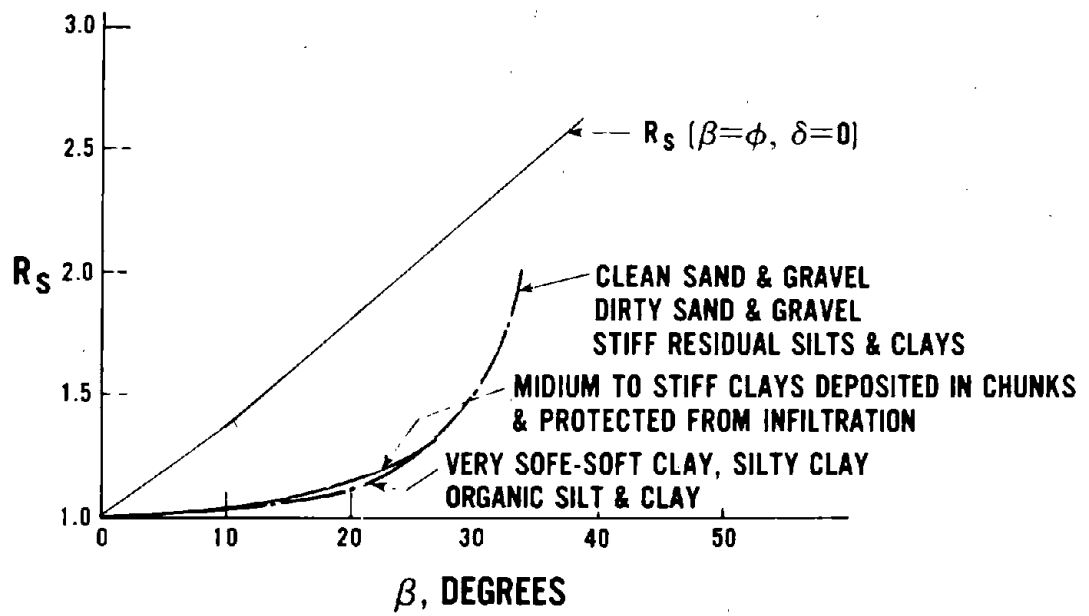

Figure 5.4. Comparison of Proposed Equation for R_s with NAVFAC Criteria

appears to be a conservative upper bound. Since the NAVFAC curves are not carried to the point where β is the steepest possible slope, eq (6) is not quite as conservative as it appears to be in this figure.

It is also of interest to examine the equation for k_a if $\beta = \phi$ and $\delta = 0$:

$$k_{a(\beta=\phi, \delta=0)} = \cos^2 \beta \quad \dots \text{eq(9)}$$

This can be rewritten in terms of slope (h/v)

$$k_a = \left(\frac{h}{\sqrt{v^2 + h^2}} \right)^2 = \frac{h^2}{v^2 + h^2} \quad \dots \text{eq(10)}$$

This equation can be converted into an expression for p that could be substituted for equation (3.2) by multiplying by the weight of soil; thus assuming $\gamma = 100 \text{ lb/ft}^3$

$$p (\phi = \beta, \delta = 0) = \frac{100h^2}{v^2 + h^2} \cdot H \quad \dots \text{eq(11)}$$

Equation 11 is simple and compact and could be included in the "standard practice".

Equation (3.3)

Equation (3.3) and the equation for heavy equipment load effects in Figure 3.2 (c):

$$p = w_e(H + H_q) + p_q;$$

$$p_q = \frac{W}{H(\lambda + x)} \left(1 - 0.6 \frac{x}{H} \right) \leq \frac{0.8W}{H(\lambda + x)} \quad \text{are derived hereafter:}$$

Figure 5.5 shows some heavy construction equipment (the wheel positions are shown by black squares) of total weight W acting through its center of gravity.

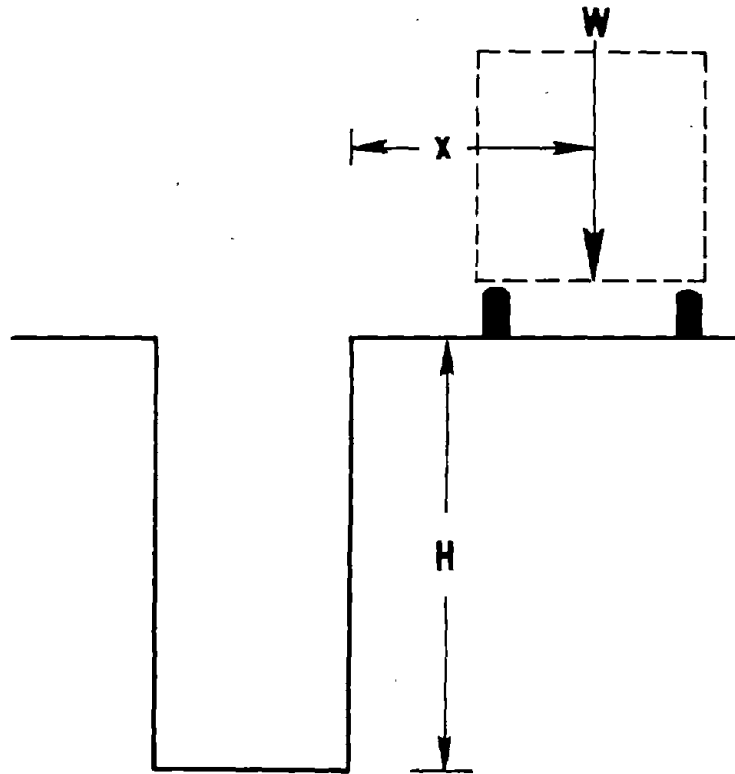

Figure 5.5 Effects of Heavy Construction Equipment

It is assumed that the effect caused by weight of the heavy equipment can be reasonably represented by an equivalent line load "q" parallel to the side of the trench.

Using Boussinesq's equations, the distribution of horizontal pressures (σ_h) against a vertical plane resulting from a line load can be calculated as:

$$\sigma_h = \frac{2q}{\pi H} \cdot \frac{m^2 n}{(m^2 + n^2)^2} \quad \dots \text{eq(1)}$$

where: H = depth of excavation

m = x/H

n = z/H

q = lineload (force/length)

x = distance from lineload to side of trench

z = depth below surface.

The dimensions used in eq (1) are shown in Figure 5.6

Terzaghi [18] recommended values of approximately twice the Boussinesque pressures. Thus the following equations are commonly used to calculate pressures against rigid retaining walls:

$$\sigma_h = \frac{4q}{\pi H} \cdot \frac{m^2 n}{(m^2 + n^2)^2} \quad \text{if } m > 0.4 \quad \dots \text{eq(2)}$$

$$\sigma_h = \frac{0.203q}{H} \cdot \frac{n}{(0.16 + n^2)^2} \quad \text{if } m \leq 0.4 \quad \dots \text{eq(3)}$$

Figure 5.7 shows a plot of the nondimensionalized measure of horizontal pressures $\sigma_h \cdot H/q$ for three values of m. The same plot shows also a

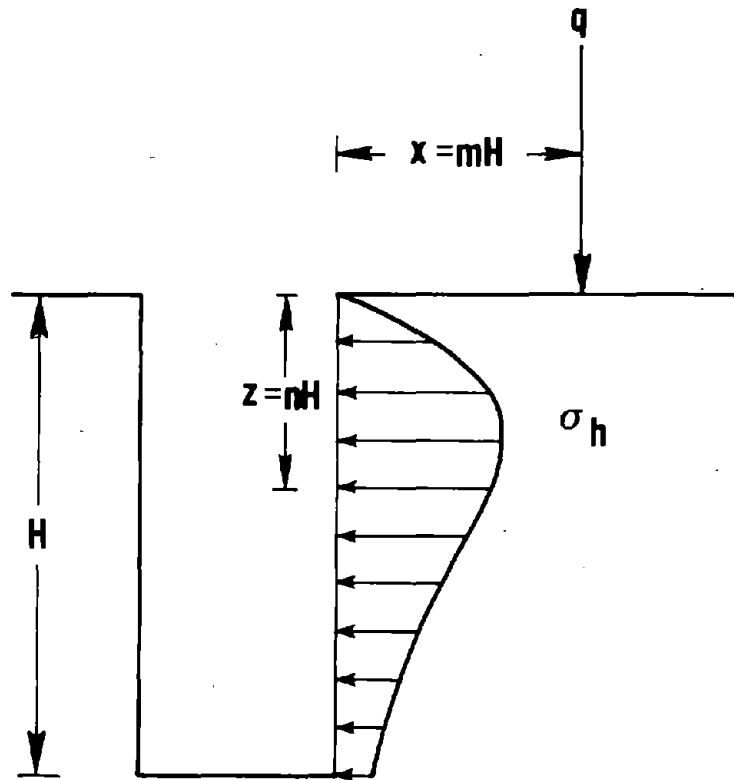

$$\sigma_h = \frac{Hq}{\pi H} \cdot \frac{m^2 n}{(m^2 + n^2)^2} \approx \frac{0.203q}{H} \cdot \frac{n}{(0.16 + n^2)^2}$$

Figure 5.6 Dimensions Used in the Derivation of Simplified Expressions for Heavy Equipment Effects

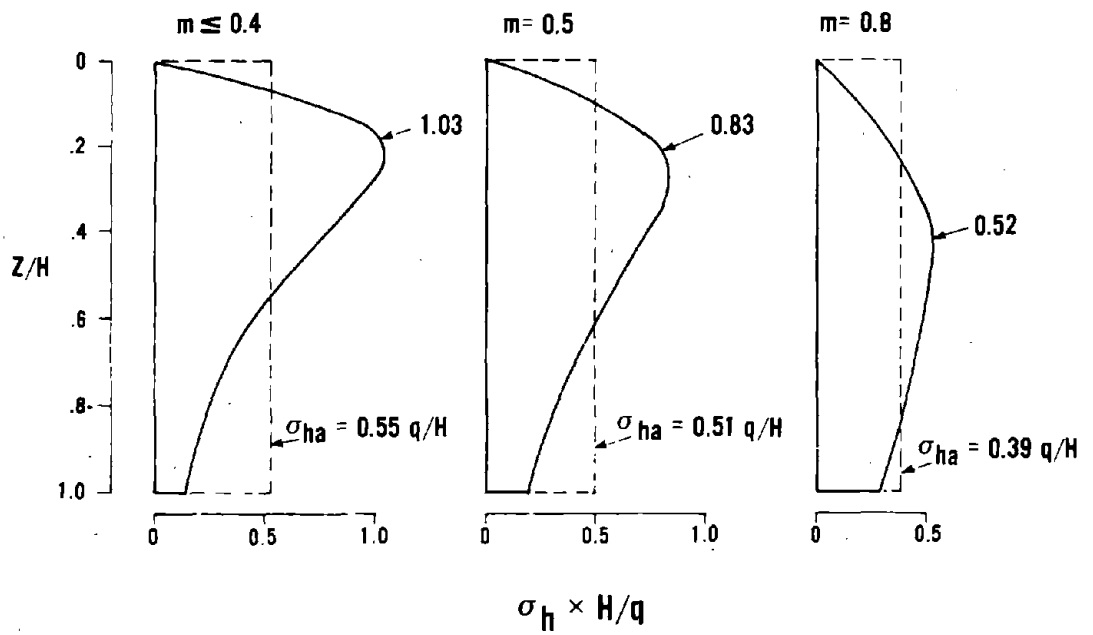

Figure 5.7 Effects of m on σ_h

uniformly distributed lateral pressure (σ_{ha}) which would produce a total resultant force on the bracing system equal to that produced by the line-load. The equivalent uniform lateral pressure can be calculated by integrating eqs. (2) and (3) as follows:

$$\text{for } m \leq 0.4; \quad \sigma_{ha} = \frac{0.203q}{H} \int_0^1 \frac{ndn}{(0.16+n^2)^2} =$$

$$= \frac{0.203q}{H} \left| \frac{-2 \cdot 0.16}{4 \times 0.16(0.16+n^2)} \right|_0^1 = 0.548 \frac{q}{H} \dots \text{eq (4)}$$

the maximum ratio of $\frac{\sigma_h}{\sigma_{ha}}$ occurs at the depth of $n = 0.231$ and is $\frac{1.030}{0.548} = 1.88$

$$\text{for } m > 0.4; \quad \sigma_{ha} = \frac{4m^2}{\pi} \cdot \frac{q}{H} \int_0^1 \frac{ndn}{(m^2+n^2)^2} =$$

$$= \frac{4m^2}{\pi} \cdot \frac{q}{H} \cdot \left| -\frac{1}{2(m^2+n^2)} \right|_{n=0}^{n=1} = \frac{2}{\pi(m^2+1)} \cdot \frac{q}{H}$$

in the practical range of values for m , $0.4 \leq m < 1$ this is closely approximated by:

$$\sigma_{ha} \approx \frac{q}{H} (.7074 - .3973 m) \approx \frac{q}{H} (0.7 - 0.4 m) \dots \text{eq(5)}$$

Thus it has been shown that σ_{ha} can be calculated by rather simple expressions. Eq (4) would be for the case where the surcharge would be at a distance of 40 percent of the depth or less from the edge of the trench. Eq (5) for distances between $0.4H$ and $1H$. Any surcharge load located further than $1H$ from the trench wall can be disregarded. For moving equipment which could be positioned close to the edge of the trench, $\sigma_{ha} = 0.5 q/h$ is a reasonable worst-case approximation. For fixed line-loads such as lanes of heavy traffic eq (5) may be appropriate.

As is apparent from Figure 5.7 and also from the ratio calculated for $m < 0.4$, $\sigma_h/\sigma_{ha} = 1.88$, the use of the average value σ_{ha} over the entire surface of the shoring is not conservative, particularly for a large H where the upper struts may be subjected to excessive loads. On the other hand, one should realize that as the distance of a piece of equipment of limited length from the edge of the trench increases, its representation by an infinite line load becomes more conservative. Another factor that must be recognized is that equipment loads are dynamic and an impact factor should be used in their representation. Recognizing all these variables, the recommended design (working) load was derived as follows:

$$q = \frac{W}{l + x} \quad \dots \text{eq(6)}$$

where: W = total load

l = length of actual load parallel to the trench

x = distance from edge of trench

by this equation the assumed lineload will decrease as the distance from the trench increases. To account for the shape of the pressure diagram and impact effects, a lateral pressure (p_q) of $1.5 \sigma_{ha}$ is recommended

thus

for $x \leq 0.4 H$ (see Figure 1)

$$p_q = \frac{0.8W}{H(l + x)} \quad \dots \text{eq(7)}$$

and for $0.4 H < x < 1H$

$$p_q = \frac{W}{H(l + x)} \left(1 - 0.6 \frac{x}{H}\right) \quad \dots, \text{eq(8)}$$

p_q should be assumed 0 if $\frac{x}{H} > 1$.

(3) Tributary Loads [Sec. 3.3.2(4)]

The recommended loads tributary to members of the shoring system are in accordance with accepted engineering practice. The load reduction for wales and sheeting is to account for "arching effects", which will cause members to experience bending moments and shear forces smaller than those produced by a uniformly distributed load.

5.4 SOIL CLASSIFICATION (Section 3.4)

A detailed commentary on the recommended soil classification systems is provided in Ref [21], which also describes field identification and testing procedures associated with the recommended systems.

5.5 SPACED SHEETING (Sec. 3.5)

It is assumed that even though spaced sheeting does not cover the entire exposed trench wall, the shoring system must still resist the same resultant force that would be resisted by a shoring system with tight sheeting. There are presently no data by which soil properties such as cohesive strength can be correlated with the ability of the soil to stand in the interval between the spaced supports without collapse or spalling. The recommended provisions are based entirely on empirical practice and on field observations reported by experienced contractors and foremen. In essence NBS could find no evidence that the present OSHA requirements with respect to spaced sheeting are unsatisfactory. In Ref [21] there is some additional information by which the ability of unbraced vertical cuts to stand in the field without collapse or spalling is correlated with recommended provisions for spaced sheeting.

5.6 RECOMMENDED SPECIAL PROVISIONS (Sec. 3.6)

The recommended requirement to shore both trenches near a trench intersection is based on data obtained in the field study [10, 17], and on the fact that a pre-loaded strut near a trench intersection could shear off the corner unless both trenches are shored.

The recommendation to permit some excavation below the bottom of the sheeting is based on the fact that this practice is presently used successfully. However, it is not recommended to permit this practice if there is any evidence that perceptible soil movement occurs below the bottom of the sheeting or trench box. As an added protection it is required to provide added strength to the bottom wale and projecting sheeting and to calculate the lateral pressure on the basis of the full trench depth.

The recommended restriction on placing objects and construction equipment near the edge of excavations extends a similar restriction in present OSHA provisions to construction equipment. However, it permits the contractor to make special provisions in tight situations.

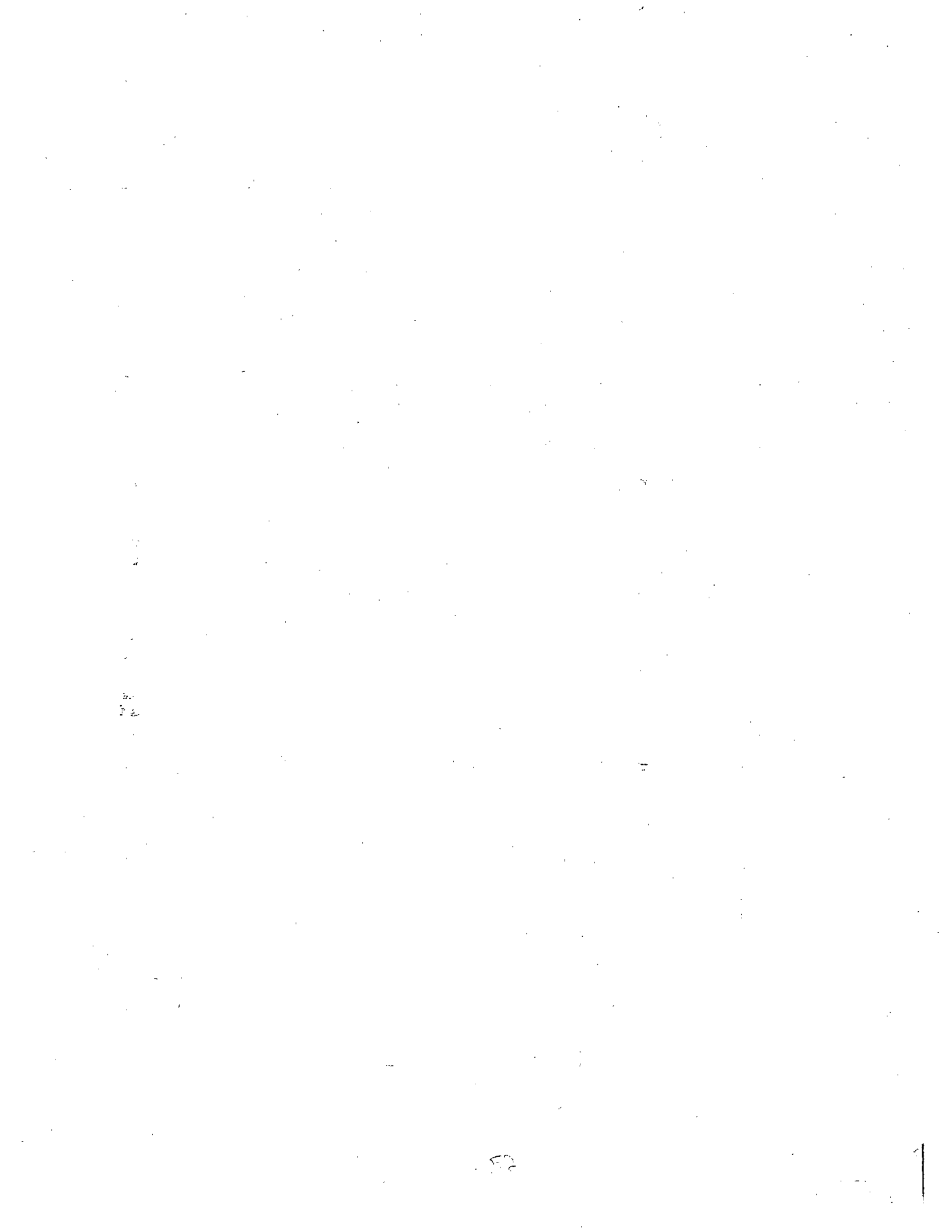

6. REFERENCES

- [1] Aluminum Association, Specification for Aluminum Structures, New York, N.Y., November 1967.
- [2] American Concrete Institute, Building Code Requirements for Reinforced Concrete (ACI 318-77), Detroit, Mich., November 1977.
- [3] American Institute for Steel Construction (AISC), Specifications for the Design, Fabrication and Erection of Steel Construction, New York, N.Y., Feb. 1969.
- [4] ASTM, Standard Methods for Evaluating Allowable Properties for Grades of Structural Lumber, ASTM 2915-74, ASTM Standards Part 22, pp 830, American Society for Testing and Materials, Philadelphia, PA, 1979.
- [5] ASTM, Conducting Strength Tests of Panels for Building Construction, ASTM E72-77, ASTM Standards Part 18, American Society for Testing and Materials, Philadelphia, PA, 1979.
- [6] Coulomb, C.A., Essai sur une Application des Regles des Maximis et Minimis a quelques Problemes de Statique Relatifs a l'Architecture, Mem. acad. roy. pres. divers savants, Vol. 7, Paris, France, 1776.
- [7] Department of the Navy, Design Manual, Soil Mechanics, Foundations and Earth Structures, NAVFAC DM-7, Chapte 10, U.S. Naval Publications and Forms Center, Philadelphia, PA, September 1971.
- [8] Fattal, S.G. and Cattaneo, L.E., Investigation of Guard Rails for the Protection of Employees From Occupational Hazards, NBSIR76-1139, National Bureau of Standards, July 1976.
- [9] Goldberg, D.T., Jaworski, W.E., and Gordon, M.D., Lateral Support Systems and Underpinning, Report No. FHWA-RD-75-129, Vol. II, Federal Highway Administration, Washington, D.C., April 1976.
- [10] Hinze, J., and Carino, N.J., A Study of Work Practices Employed to Protect Workers in Trenches, NBSIR No. 79-1942 National Bureau of Standards, March 1980.
- [11] Knab, L.I., Yokel, F.Y., Galligan, W.L., and Senft, J.F., A Study of Lumber Used for Bracing Trenches in the United States, BSS 122 National Bureau of Standards, Washington, D.C., March 1980.
- [12] National Forest Products Association, National Design Specifications for Wood Construction, Washington, D.C., June 1977.
- [13] Occupational Safety and Health Administration, Safety and Health Regulations for Construction, Subpart P, Excavation, Trenching and Shoring, Federal Register, Vol. 39, No. 122, June 24 1974.

- [14] Peck, R.B., Deep Excavations in Soft Ground, Proceedings of the International Conference on Soil Mechanics and Foundation Engineering, State-of-the-Art Volume, pp. 225-250, Mexico City, 1969.
- [15] Peck, R.B., Hanson, W.E., and Thurnburn, T.H., Foundation Engineering, Chapter 27, John Wiley and Sons, New York, N.Y., Jan. 1974.
- [16] Salomone, L.A., and Yokel, F.Y., Proceedings, Federal Workshop on Excavation Safety, September 19 and 20, 1978, NBSIR 79-1935, December 1979.
- [17] Salomone, L.A., and Yokel, F.Y., An Analysis of the Response from an Associated General Contractors of America Survey of Trenching and Shoring Practices, NBSIR 79-1936 National Bureau of Standards, Washington, D.C., January 1980.
- [18] Terzaghi, K., Anchored Bulkheads, Transactions ASCE, Vol. 119, p. 1243, New York, N.Y., 1954.
- [19] Tschebotarioff, T. P., Foundation, Retaining and Earth Structures, McGraw-Hill, New York, NY, 1973
- [20] United States Steel Company, Sheet Piling Manual, U.S. Steel, Pittsburgh, Pa., July 1975.
- [21] Yokel, F.Y., Tucker, R.L., and Reese, L.C., Soil Classification for Construction Practice in Shallow Trenches, BSS 121 National Bureau of Standards, Washington, D.C., March 1980.

7. ACKNOWLEDGMENT

The assistance of the following persons collectively contributed to the development of the recommendations presented in this report:

Mr. James Bryson from NBS provided direction and valuable assistance as chief of the construction safety section.

Professor Jay B. Kim of Bucknell University carried out a major phase of this study which consisted of a summary of the state-of-the-art and an analytical study which was part of the assessment of present trenching practices and the technical provisions in the present OSHA regulations.

Professor William D. Kovacs of Purdue University prepared the data for sloping backfill shown in Figure 5.3

Professors Richard L. Tucker and Lymon C. Reese from the University of Texas conducted the soil classification study which provided the background information for Tables 3.1, 3.2 and 3.3.

Dr. Lawrence I. Knab from NBS, Mr. William L. Galligan and Mr. B. Allen Bentsen from the Forest Product Laboratory, and Professor John F. Senft from Purdue University, conducted the timber study on which Table A.1 is based.

Professor Jimmie Hinze from the University of Missouri at Columbia conducted the field study.

Mr. Lawrence A. Salomone from NBS prepared the report on the National Workshop and analyzed the results of an Associated General Contractor's Survey on Trenching and shoring practices.

Dr. Nicholas J. Carino of NBS reviewed and revised the field study report.

Messrs. William S. Zoino, James J. Schnabel, James H. Kleinfelder and John P. Guaedinger, Consulting Engineers and members of the Association of Soil and Foundation Engineers (ASFE) helped define the role of the professional engineer, and provided many valuable comments which are reflected in the recommendations made in Tables 3.1, 3.2 and 3.3 and in Section 4 of this report. They also helped formulate the overall approach in the Recommended Technical Provisions.

Messrs. Arthur L. Schmuhl and John P. Ashooh of the Associated General Contractors (AGC), John H. Panullo and Robert G. Griffith of the National Utility Contractor's Association (NUCA) and Patrick J. Higgins of the National Association of Plumbing Heating and Cooling Contractors (NAPHCC) surveyed field practices and received assessment of current OSHA regulations among members of their associations and gave valuable advice and assistance.

Mr. James L. Lapping, Professor Jack O. Mickle and Messrs. M. Ahlquist, Carl F. Gill and Robert C. Mack, Sr., of the AFL-CIO provided invaluable guidance in a workshop and Task-Force report on Trenching Hazards Identification.

Messrs. Peter J. Ellis, George Bradberry, W.M. "Red" Cass and David O. Plank of the excavation and shoring industry provided invaluable guidance and advice and helped develop the approach taken in this report.

Messrs. Thomas H. Seymour, David O. Hadden and Allen E. "Ike" Martin of OSHA provided much needed assistance and guidance and throughout this project.

APPENDIX A. . TIMBER SHORING

A.1 General

There are two reasons for the separate consideration of timber shoring in this appendix:

(1) Even though hardwood is widely used throughout the U.S. in timber shoring practice, there are presently no hardwood standards and grading rules and procedures similar to those for softwood. Thus engineers have no guidance on allowable working stresses and there is no effective procedure to assure quality control in the field.

(2) NBS could not demonstrate that traditional U.S. timber shoring practice complies with the recommended standard practice.

Section A.2 of this appendix contains a recommendation on allowable working stresses in hardwood trenching timber. Proposed grading rules were presented in Ref. [11]. Sections A.3 and A.4 contain information on, and an assessment of, traditional timber shoring practice. Timber sizes which comply with the recommended standard practice are shown in tables A.7, A.8 and A.9. Appendix A supplements the recommended standard practice.

A.2 Recommended Working Stresses in Hardwood Timber Shoring

Recommended allowable working stresses for hardwood trenching lumber are shown in Table A.1. The recommendation was developed in the NBS trenching lumber study and is taken from Ref [11]. Note that various species and combinations of species are considered. "Grade No 2" was used as the basis for the recommendation. This is based on the findings of the NBS field study, and will require that some of the members currently used in trenching will have to be discarded or downgraded.

Note that certain limitations on "wane" have to be observed for No. 2 grades in accordance with the 1977 Grading rules of the Southern Pine Inspection Bureau.

It is strongly recommended that industry extend present grading practice to hardwood trenching lumber and consider developing special provisions for wane. In the meantime, contractors and suppliers should comply with the 1977 SPIB softwood grading rules for No. 2 grade when selecting and supplying trenching lumber (struts, wales and spaced sheeting). These rules should be followed, for all trenching lumber, even that used for timber shoring in conjunction with traditional practice.

The following symbols are used in Table A.1.

F_b = allowable bending stress (flexure)

F_t = allowable tensile stress (axial tension)

Table A.1 Allowable Unit Stresses in psi for Hardwood Trenching Lumber^a

Hardwood group ^b	F _b	F _t	F _c	F _v	F _{c⊥}	E
2 to 4 in. thick, 2 to 14 in. wide						
White oak ^c	875	575	550	105	355	800,000
Mixed oak ^d	850	550	500	80	355	800,000
Mixed hardwoods I ^e	725	475	375	65	165	800,000
Mixed hardwoods II ^f	600	400	350	50	115	800,000
5 in. and thicker, 5 to 20 in. wide						
White oak ^c	975	650	525	120	355	800,000
Mixed oak ^d	925	625	475	90	355	800,000
Mixed hardwoods I ^e	800	550	350	75	165	800,000
Mixed hardwoods II ^f	675	450	325	60	115	800,000

^a Ref. Southern Pine Inspection Bureau Grading Rules, 1977 edition, for general grade description as follows:

Grade	Paragraph	Size
No. 2	313	2 to 4 in. thick, 2 to 4 in. wide
No. 2	343	2 to 4 in. thick, 5 to 14 in. wide
No. 2 SR	406	5 in. and thicker, 5 to 20 in. wide

Assumes 10-yr. load duration basis. For new (first use) lumber, adjustments for load duration may be made: for 1-yr. duration multiply by 1.1; for 1 wk., multiply by 1.25; for 2 days, multiply by 1.30. Load duration adjustments for used trenching lumber are not recommended. For hardwood trenching lumber, requirements are waived for manufacture, compression wood, firm knots, skips, stain and warp. Holes limited as knots; wane limited as given for No. 2 grade in SPIB, 1977 edition.

^b Hardwood species defined per ASTM D 1165.

^c White oak: The following white oaks--bur, chestnut, live, overcup, post, swamp chestnut, swamp white, white.

^d Mixed oak: Red oak (black, cherry bark, laurel, northern red, pin, scarlet, southern red, water, willow); white oak (footnote c).

^e Mixed hardwoods I: Ash (black, blue, green, Oregon); beech; birch (sweet, yellow); cherry; elm (American, rock, slippery); hackberry; hickory (mockernut, pignut, shagbark, shellbark); locust (black, honeylocust); magnolia (cucumber, southern, sweetbay); maple (bigleaf, black, red, silver, sugar); mixed oak (footnote d); pecan (bitternut hickory, nutmeg hickory, pecan, water hickory); red alder; sassafras; sugarberry; sweetgum; sycamore; tanoak; tupelo (black, water); yellow poplar. Excludes all cottonwood, all aspen, basswood, and balsam poplar.

^f Mixed hardwoods II: All hardwoods in Mixed hardwoods I (footnote e) plus black and eastern cottonwood; quaking and bigtooth aspen; basswood. Excludes balsam poplar.

F_c = allowable compressive stress parallel to grain

F_v = allowable shear stress

$F_{c\perp}$ = allowable compressive stress perpendicular to grain

E = modulus of elasticity (Young's Modulus)

F_b and F_c should be considered for flexural stresses in wales, and compressive stresses in struts, respectively.

A.3 Traditional Timber Shoring Practice

Traditional timber shoring practice varies widely from location to location and frequently depends on such variables as sizes and characteristics of available timber, soil conditions, and local work practices. In some locations these practices have been used for many years and appear to be satisfactory to all the parties concerned. Three such locations are the State of Wisconsin, New York City, and the State of California (where mainly softwood is used).

In order to assess traditional lumber practice, an attempt has been made to compile tables of typical sizes by combining common elements of available codes and local practices. Table A.2 is for skip shoring (spaced sheeting), Table A.3 for tight sheeting and Table A.4 shows the increase in strut sizes with trench width for trenches wider than 4 ft. Table A.2 is for Type A and B soils since skip shoring would not be used in Type C soils. Table A.3 is for Type B and Type C soils since tight sheeting is not likely to be used in Type A soils. The following correlation should be used in conjunction with the matrix soil classification system.

<u>Table</u>	<u>Soil Type</u>	<u>Soil Class</u>
A.2	A	I
A.2	B	II, (III)*
A.3	B	II
A.3	C	III, IV

* Class III soil falling in this category would be fissured medium clay.

A.4 Assessment of Traditional Timber Shoring Practice

Traditional timber practice can be compared with the proposed standard practice. This is done hereafter, making the following assumptions:

1. Allowable working stresses are those for "Mixed Hardwood I," No. 2 grade.

Table A-2 Typical Minimum Sizes of Timber Skip Shoring (inches)

Trench Depth (ft)	Soil Type	Minimum Strut Size			Minimum Size of Upright					Minimum Wale Size
		Horizontal Center-to-Center Strut Spacing			Horizontal Center-to-Center Spacing of Uprights					
		4 ft	6ft	8 ft	2 ft	3 ft	4 ft	6 ft	8 ft	
5-10	A		4 x 4	4 x 4				2 x 6	2 x 8	None Required
10-15	A	4 x 4	4 x 4				2 x 6	3 x 8		None Required
5-10	B		4 x 4			2 x 6				4 x 6
10-15	B		4 x 6		2 x 6					4 x 6
10-15	B	4 x 4			2 x 6					4 x 6

- (a) All lumber sizes are actual sizes in inches
- (b) Strut sizes are for 4 ft trench width. For wider trenches, see Table A-4 rows 1 and 2
- (c) Vertical center-to-center spacing of struts and wales should not exceed 4 ft.
- (d) 3 x 6 struts can be substituted for 4 x 4 struts in trenches of up to 4-ft width.

Table A.3 Typical Minimum Sizes of Timber Shoring of Trenches

Trench Depth (ft)	Soil Type	Minimum Strut and Wale Size							Maximum Center-to-Center Vertical Wale Spacing (ft)	Minimum Sheeting Thickness (in)
		Horizontal Center-to-Center Strut Spacing (ft)								
		6	8	10	12	14	16	20		
5-10	Type B	4 x 4	6 x 6	6 x 6	8 x 8	8 x 8	10 x 10	10 x 10	5	2
5-10	Type C	6 x 6	8 x 8	8 x 8	8 x 10	10 x 10	10 x 12	12 x 12	5	3
10-15	Type B	6 x 6	6 x 8	8 x 8	8 x 10	10 x 10	10 x 12	12 x 12	5	2
10-15	Type C	6 x 8	8 x 8	10 x 10	10 x 10	10 x 12	12 x 12	---	5	3
15-20	Type B	6 x 8	8 x 8	8 x 10	10 x 10	10 x 12	12 x 12	---	5	3
15-20	Type C	8 x 8	10 x 10	10 x 12	12 x 12	12 x 12	---	---	5	3

- (a) All lumber sizes are actual sizes in inches.
- (b) Strut sizes are for 4 ft. trench width. For wider trenches, also see Table A.4.
- (c) For strut spacing greater than 10 ft., insert intermediate struts before workers enter trench.
- (d) If vertical distance from the center of the lowest strut to the bottom of the trench exceeds 2 1/2 ft., sheeting shall be firmly embedded or mudsill shall be used. The vertical distance from the center of the lowest strut to the bottom of the trench shall not exceed 36 in, or 42 in if mudsill is used.

Table A-4 Adjustment of Strut Size for Trench Width

Trench Width (ft)	Strut Sizes in Inches (Read Down for Equivalent Size)					
4	4 x 4	4 x 6	6 x 6	6 x 8	8 x 8	8 x 10
6	4 x 4	4 x 6	6 x 6	6 x 8	8 x 8	8 x 10
9	4 x 6	6 x 6	6 x 6	6 x 8	8 x 8	8 x 10
12	6 x 6	6 x 6	6 x 8	8 x 8	8 x 8	8 x 10
15	6 x 6	6 x 6	6 x 8	8 x 8	8 x 10	10 x 10

Note: 10 x 10 or larger sizes need no adjustment.

2. A 33 percent increase is allowed for working stresses since the shoring is for short term excavations.
3. 80 percent of the calculated moment is used for wales, and 100 percent of the calculated compressive load for struts (in accordance with recommended standard practice).
4. Strut load effects include the effect of a 240 lb downward load in the center of the strut.
5. It was conservatively assumed that rectangular wales may be installed with the larger cross sectional dimension vertically, and that wales are not continuous over several struts (simply supported beams with no end restraint).

Tables A.5 and A.6 contain an analysis of Tables A.2 and A.3, respectively. They have the same format as Tables A.2 and A.3, but instead of the member size they give a "stress ratio": allowable working stress/actual working stress. If the actual working stress is greater than the allowable stress this ratio is smaller than one, and the implicit safety margin is less than that used in standard design practice.

In accordance with Table A.1, the allowable stress could be 1.3 times the stresses shown in the Table in a short-term excavation where the timber is not re-used. Thus if the "stress ratio" is 0.78 the member would still meet the requirements of the standard practice, provided it has not been used before. In every case where the stress ratio is below 0.78, the member does not meet the requirements of the standard practice.

An analysis of Table A.2 for skip shoring is presented in Table A.5. Stress ratios for struts are calculated for a 4 ft wide trench.

The stress ratios for the struts in Type A soils indicate that the strut sizes comply with the standard practice. In type B soil there is a 20 percent overstress in new struts and a 50 percent overstress for re-used struts. The wales used are in all instances substantially overstressed.

Table A.6 shows an analysis of Table A.3 for tight sheeting. Two types of stress ratios are shown for spacing larger than 10 ft. The left number shows the stress ratio without intermediate struts and the right number with intermediate struts (see footnote c to Table A.3). The analysis indicates that while struts are reasonably in compliance with the standard practice, again wales are much undersized, particularly for spacings up to 10 ft where no intermediate struts are required.

The question needs to be asked why timber shoring does not fail more frequently if the wales are as undersized as Table A.5 would indicate. It is assumed that several factors combine to produce this phenomenon:

- (1) Most timber members can probably be stressed to 2 to 3 times their allowable stress or more before failure actually occurs.

Table A.5 Analysis of Table A.2

Trench Depth (ft)	Soil Type	Struts			Wales
		Horizontal Spacing (ft)			
		4	6	8	
5-10	A		1.13	0.92	
			1.15 ^{a/}	0.96	
10-15	A	1.13	0.85		
		1.15	0.88		
5-10	B		0.67		.29
			0.71		
10-15	B		0.72		.18
10-15	B	0.67			.37
		0.71			

^{a/} Bottom numbers are for the case where 3x6 struts are substituted for 4x4 struts.

Table A.6 Analysis of Table A.3

Trench Depth (ft)	Soil Type	Struts or Wales	Horizontal Center-to-Center Spacing (ft)										
			6	8	10	12 ^{a/}	14 ^{a/}	16 ^{a/}	20 ^{a/}				
5-10	B	S	.80	.97	.79	1.19	2.30	1.03	1.99	1.42	2.78	1.14	2.24
		W	.20	.25	.19	.26	1.05	.19	.77	.29	1.15	.18	.74
5-10	C	S	.66	.90	.73	.76	1.49	.82	1.62	.86	1.71	.83	1.65
		W	.22	.30	.19	.16	.66	.19	.75	.17	.69	.16	.64
10-15	B	S	.87	.88	.96	1.01	1.97	1.09	2.14	1.15	2.26	1.11	2.19
		W	.30	.22	.25	.22	.88	.25	1.01	.23	.92	.21	.85
10-15	C	S	.60	.61	.77	.64	1.27	.66	1.31	.69	1.38	--	--
		W	.20	.20	.25	.17	.68	.15	.60	.17	.67	--	--
15-20	B	S	.88	.90	.91	.95	1.88	.98	1.94	1.04	2.05	--	--
		W	.30	.30	.27	.26	1.03	.23	.90	.25	1.0	--	--
15-20	C	S	.61	.72	.69	.69	1.38	.60	1.18	--	--	--	--
		W	.26	.29	.22	.22	.89	.16	.65	--	--	--	--

^{a/} left number in column is for full unsupported wale length, right number with intermediate strut supports.

(2) Wales are very flexible members and lateral soil pressures will tend to decrease as they bend away from the trenchwall. The 20 percent stress reduction allowed in the standard practice may only partially account for this effect.

(3) Lateral design soil pressures recommended in the standard practice are probably much larger than those actually experienced in most (but not all) instances (this is discussed in Reference [21]).

The following conclusions can be drawn from the analysis of traditional timber practice:

1. The strut sizes used are reasonably in compliance with standard practice. Even in instances where they are not in compliance, there is probably still a safety margin left.
2. Wale sizes are in all instances deficient and it can not be analytically demonstrated that there is an adequate safety margin against failure.

Since, in spite of the results of this analysis, NBS could find no evidence that traditional timber practice, if properly executed, is unsafe, consideration could perhaps be given to temporarily exempting conventional timber shoring from the lateral load requirements until lateral load effects can be further studied by actual measurements in the field. If such an approach is adopted, it may be more reasonable to endorse proven local shoring practices on a regional basis, only where such shoring is widely used. It is not recommended to use a single scheme such as Tables A.2, and A.3 nationwide, since local practice evolved on the basis of local workmanship, material supplies and soil conditions.

It has been previously noted that the struts used in conventional timber shoring reasonably comply with the requirements of the standard practice. Thus, with relatively minor adjustments (mostly upgrading) all struts could be brought into compliance. It should also be noted that the adjustments to bring skip shoring into compliance with the standard practice would only require substantial upgrading of the wales, which are used rather infrequently. Tables for timber shoring, which would be in compliance with the recommended standard practice are given below. Table A.7 is for skip shoring, Table A.8 is for struts and Table A.9 for wales. In Table A.9 it was assumed that wales would be used with the long cross-sectional dimension horizontal to give maximum moment resistance, and that the overstress in large spans would not exceed 100 percent before the intermediate struts are installed. It is recommended to retain traditional practice for uprights in skip shoring and sheeting thickness in tight sheeting, since this practice is widely used in all types of excavations and there is no evidence that it is inadequate. Tables A.7 through A.9 are for short-term excavations.

Table A.7 Timber Skip Shoring Sizes in Accordance with Standard Practice

Trench Depth (ft)	Soil Type	Strut Sizes (in)			Sizes of Upright (in)				Wale Sizes (in)
		Horizontal Spacing (ft)			Horizontal Spacing (ft)				
		4	6	8	2	3	4	6	
5-10	A	4 x 4	4 x 4				2 x 6	2 x 8	
10-15	A	4 x 4	4 x 4				2 x 6	3 x 8	
5-10	B		4 x 6			2 x 6			6 x 8
10-15	B		6 x 6		2 x 6				8 x 8
10-15	B	4 x 6			2 x 6				6 x 6

- Notes:
- (1) All lumber sizes are actual (not nominal) sizes in inches.
 - (2) 3 x 6 struts can be substituted for 4 x 4 struts in trenches up to 4 ft width. For trenches wider than 4 ft use Table A.4 for strut size adjustment.
 - (3) All horizontal spacing is center-to-center.
 - (4) Vertical center-to-center spacing of struts or wales not to exceed 4 ft.
 - (5) Longer side of wale cross section to be horizontal.

Table A.8 Timber Shoring Strut Sizes in Accordance with Standard Practice

Trench Depth (ft)	Soil Type	Horizontal Strut Spacing (ft)						
		6	8	10	12	14	16	20
5-10	B	4 x 6	6 x 6	6 x 6	8 x 8	8 x 8	8 x 10	10 x 10
	C	6 x 8	8 x 8	8 x 10	8 x 10	10 x 10	10 x 12	12 x 12
10-15	B	6 x 6	6 x 8	8 x 8	8 x 10	10 x 10	10 x 12	12 x 12
	C	8 x 8	8 x 10	10 x 10	10 x 12	12 x 12		
15-20	B	6 x 8	8 x 8	8 x 10	10 x 10	10 x 12	12 x 12	
	C	8 x 10	10 x 12	12 x 12				

- (1) All lumber sizes are actual (not nominal) sizes in inches.
- (2) For trenches wider than 4 ft adjust strut sizes by Table A.4.
- (3) Vertical spacing not to exceed 5 ft center-to-center.
- (4) All horizontal spacing is center-to-center.

Table A.9 Timber Shoring Wale Sizes in Accordance with Standard Practice

Trench Depth (ft)	Soil Type	Horizontal Strut Spacing (ft)						Sheeting Thickness (in)
		6	8	10	12	14	16	
5-10	B	6 x 8	8 x 10	10 x 10	10 x 10	10 x 12	12 x 12	2
	C	8 x 10	10 x 12	12 x 12*	12 x 12			3
10-15	B	8 x 8	10 x 10	10 x 12*	10 x 12	12 x 12		2
	C	10 x 12	12 x 12*	12 x 12				3
15-20	B	8 x 10	10 x 12	12 x 12*	12 x 12			3
	C	12 x 12	12 x 12					3

USE INTERMEDIATE STRUTS TO THE RIGHT OF LINE

- (1) All lumber sizes are actual (not nominal) sizes in inches.
- (2) Vertical spacing not to exceed 5 ft center-to-center.
- (3) All horizontal spacing is center-to-center.
- (4) Long side of cross-section of rectangular members to be horizontal.
- (5) * indicates slight overstress.
- (6) Wale sizes to the right of dividing line require insertion of intermediate strut before workers enter the trench.
- (7) If vertical distance from the center of the lowest wale to the bottom of the trench exceeds 2 1/2 ft, sheeting shall be firmly embedded below the bottom of the trench or mudsill shall be used. The vertical distance from the center of the lowest wale to the bottom of the trench shall not exceed 3 ft, or 3 1/2 ft if mudsill is used.

NBS TECHNICAL PUBLICATIONS

PERIODICALS

JOURNAL OF RESEARCH—The Journal of Research of the National Bureau of Standards reports NBS research and development in those disciplines of the physical and engineering sciences in which the Bureau is active. These include physics, chemistry, engineering, mathematics, and computer sciences. Papers cover a broad range of subjects, with major emphasis on measurement methodology and the basic technology underlying standardization. Also included from time to time are survey articles on topics closely related to the Bureau's technical and scientific programs. As a special service to subscribers each issue contains complete citations to all recent Bureau publications in both NBS and non-NBS media. Issued six times a year. Annual subscription: domestic \$17; foreign \$21.25. Single copy, \$3 domestic; \$3.75 foreign.

NOTE: The Journal was formerly published in two sections: Section A "Physics and Chemistry" and Section B "Mathematical Sciences."

DIMENSIONS/NBS—This monthly magazine is published to inform scientists, engineers, business and industry leaders, teachers, students, and consumers of the latest advances in science and technology, with primary emphasis on work at NBS. The magazine highlights and reviews such issues as energy research, fire protection, building technology, metric conversion, pollution abatement, health and safety, and consumer product performance. In addition, it reports the results of Bureau programs in measurement standards and techniques, properties of matter and materials, engineering standards and services, instrumentation, and automatic data processing. Annual subscription: domestic \$11; foreign \$13.75.

NONPERIODICALS

Monographs—Major contributions to the technical literature on various subjects related to the Bureau's scientific and technical activities.

Handbooks—Recommended codes of engineering and industrial practice (including safety codes) developed in cooperation with interested industries, professional organizations, and regulatory bodies.

Special Publications—Include proceedings of conferences sponsored by NBS, NBS annual reports, and other special publications appropriate to this grouping such as wall charts, pocket cards, and bibliographies.

Applied Mathematics Series—Mathematical tables, manuals, and studies of special interest to physicists, engineers, chemists, biologists, mathematicians, computer programmers, and others engaged in scientific and technical work.

National Standard Reference Data Series—Provides quantitative data on the physical and chemical properties of materials, compiled from the world's literature and critically evaluated. Developed under a worldwide program coordinated by NBS under the authority of the National Standard Data Act (Public Law 90-396).

NOTE: The principal publication outlet for the foregoing data is the Journal of Physical and Chemical Reference Data (JPCRD) published quarterly for NBS by the American Chemical Society (ACS) and the American Institute of Physics (AIP). Subscriptions, reprints, and supplements available from ACS, 1155 Sixteenth St., NW, Washington, DC 20056.

Building Science Series—Disseminates technical information developed at the Bureau on building materials, components, systems, and whole structures. The series presents research results, test methods, and performance criteria related to the structural and environmental functions and the durability and safety characteristics of building elements and systems.

Technical Notes—Studies or reports which are complete in themselves but restrictive in their treatment of a subject. Analogous to monographs but not so comprehensive in scope or definitive in treatment of the subject area. Often serve as a vehicle for final reports of work performed at NBS under the sponsorship of other government agencies.

Voluntary Product Standards—Developed under procedures published by the Department of Commerce in Part 10, Title 15, of the Code of Federal Regulations. The standards establish nationally recognized requirements for products, and provide all concerned interests with a basis for common understanding of the characteristics of the products. NBS administers this program as a supplement to the activities of the private sector standardizing organizations.

Consumer Information Series—Practical information, based on NBS research and experience, covering areas of interest to the consumer. Easily understandable language and illustrations provide useful background knowledge for shopping in today's technological marketplace.

Order the above NBS publications from: Superintendent of Documents, Government Printing Office, Washington, DC 20402.

Order the following NBS publications—FIPS and NBSIR's—from the National Technical Information Services, Springfield, VA 22161.

Federal Information Processing Standards Publications (FIPS PUB)—Publications in this series collectively constitute the Federal Information Processing Standards Register. The Register serves as the official source of information in the Federal Government regarding standards issued by NBS pursuant to the Federal Property and Administrative Services Act of 1949 as amended, Public Law 89-306 (79 Stat. 1127), and as implemented by Executive Order 11717 (38 FR 12315, dated May 11, 1973) and Part 6 of Title 15 CFR (Code of Federal Regulations).

NBS Interagency Reports (NBSIR)—A special series of interim or final reports on work performed by NBS for outside sponsors (both government and non-government). In general, initial distribution is handled by the sponsor; public distribution is by the National Technical Information Services, Springfield, VA 22161, in paper copy or microfiche form.

BIBLIOGRAPHIC SUBSCRIPTION SERVICES

The following current-awareness and literature-survey bibliographies are issued periodically by the Bureau:

Cryogenic Data Center Current Awareness Service. A literature survey issued biweekly. Annual subscription: domestic \$25; foreign \$30.

Liquefied Natural Gas. A literature survey issued quarterly. Annual subscription: \$20.

Superconducting Devices and Materials. A literature survey issued quarterly. Annual subscription: \$30. Please send subscription orders and remittances for the preceding bibliographic services to the National Bureau of Standards, Cryogenic Data Center (736) Boulder, CO 80303.

