



Controlling the Ergonomic Hazards of Wiring Tasks for Household Appliances

To cite this article: (1999) Controlling the Ergonomic Hazards of Wiring Tasks for Household Appliances, Applied Occupational and Environmental Hygiene, 14:5, 289-291, DOI: [10.1080/104732299302855](https://doi.org/10.1080/104732299302855)

To link to this article: <https://doi.org/10.1080/104732299302855>



Published online: 30 Nov 2010.



Submit your article to this journal [↗](#)



Article views: 17



Citing articles: 1 View citing articles [↗](#)

Hazard Controls

Controlling the Ergonomic Hazards of Wiring Tasks for Household Appliances

From the National Institute for Occupational Safety and Health

Definition of Hazard

Employees who perform repetitive wiring tasks on assembly lines may be at risk of developing carpal tunnel syndrome and other musculoskeletal disorders of the hand, wrist, and arm. Because 88 percent of household appliances are electrically powered, many workers assembling household appliances perform wiring operations. Some workers attach up to five wires during a 20-second cycle time. Workers who make the connections by hand often wrap their fingers with tape at the location of contact stresses. The average amount of force required to connect a standard crimp terminal to its tab varies from 12 to 32 lb., depending on the gauge of the wire.

Description of Controls

Engineering controls should be the primary means for reducing the ergonomic risks associated with wiring household appliances. The following controls should be considered:

Low-Insertion-Force (LIF) Terminals

Some appliance manufacturers have begun using low-insertion-force terminals to reduce the amount of force required to make electrical connections. LIF terminals have a lock-and-release mechanism to keep the terminal in place once it is connected. LIF terminals provide sensory feedback because the worker can feel when the terminal is seated. Standard-crimp terminals require approximately 12 to 32 lb. of force to attach to the tab, whereas LIF termi-

nals require approximately 6 lb. of force to attach—a reduction of at least half. These commercially available terminals reduce the contact forces to the forefinger and thumb, eliminating the need for workers to use hand tools to wrap their fingers with tape (see Figure 1).

Pneumatic Hand Tools

If LIF terminals are not practical, a pneumatic terminal insertion tool can be used for connecting terminals. The pneumatic tool can consist of a lightweight riveter having a special jackset for terminal installation. A riveter used at one company is capable of driving 1/8- to

3/8-inch rivets. The riveter is typically used with multiple strokes, although some wires are inserted with a single stroke. The tool is suspended from an articulating arm or a balancer to support the 2-lb. tool and the air hose. The cost of this commercially available tool varies from \$570 to \$830, depending on whether it has a balancer or an articulating arm. The price does not include making the jackset, which must be made in-house by tool-and-die workers. Most appliance plants have a tool-and-die department that can easily make the simple jackset for approximately \$50. This pneumatic tool is well accepted by workers and is being used for many wiring tasks.

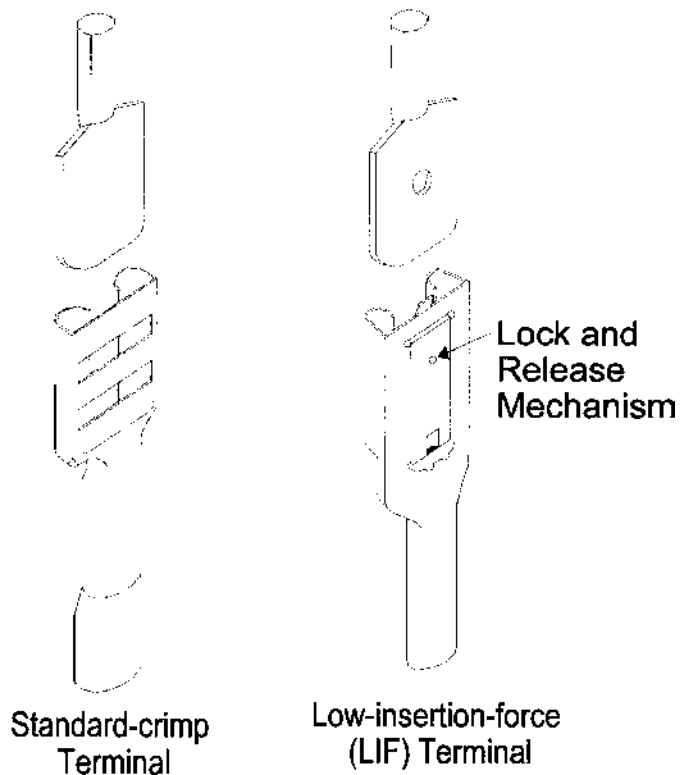

FIGURE 1
Two terminal options.

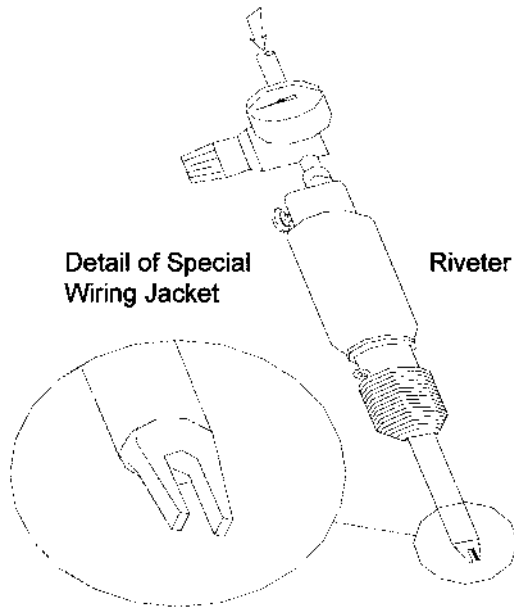

FIGURE 2
Pneumatic hand tool.

The company mentioned above has purchased 50 of the pneumatic impact tools for wiring jobs and has reported a 32 percent reduction in faulty electrical wiring and a reduction in new carpal tunnel syndrome cases (see Figure 2).

Ergonomically Designed, Manual Terminal-Insertion Tools

If LIF terminals and pneumatic tools are not feasible, another method that alleviates some of the stresses of wiring is a manual terminal-insertion tool. NIOSH researchers have designed a tool with which appliance assemblers can make electrical connections. This tool is not commercially available, but can be made by tool-and-die workers in-house for approximately \$50. Each end of the tool has a slot (one for large terminals, the other for small terminals) in which the terminals fit. The connector fits into the end of the tool so the assembler does not have to use a pinch grip to hold the connector. The size of the end may vary, depending on the wire gauge. The tool is designed to move the forces from the small surface area of the fingers to the larger surface

area of the assembler's hand. The handle is designed to conform to the worker's hand. This tool may take more time to use until assemblers become accustomed

to it, and not all connections can be made with the tool because of limited access. A similar tool can also be made for flag-type terminals (see Figure 3).

Properly Designed Pliers

If LIF terminals and specially designed tools are not feasible, pliers are preferred to fingers for terminal installation because they move the forces from the fingers to the larger surface area of the hand. If pliers are used as an interim measure, a handle length of at least 4 inches (preferably 5 inches) should be used to prevent the handle base from pressing into the worker's palm; it should also have a spring return to maintain an open position. The pliers should be without finger grooves and should have handles that are almost straight (handle curvature should be no more than 1/2 inch). The high point of the handle curve should rest at the base of the palm, and handles should be identical for use in either hand. Such pliers are commercially available for approximately \$30 (see Figure 4).

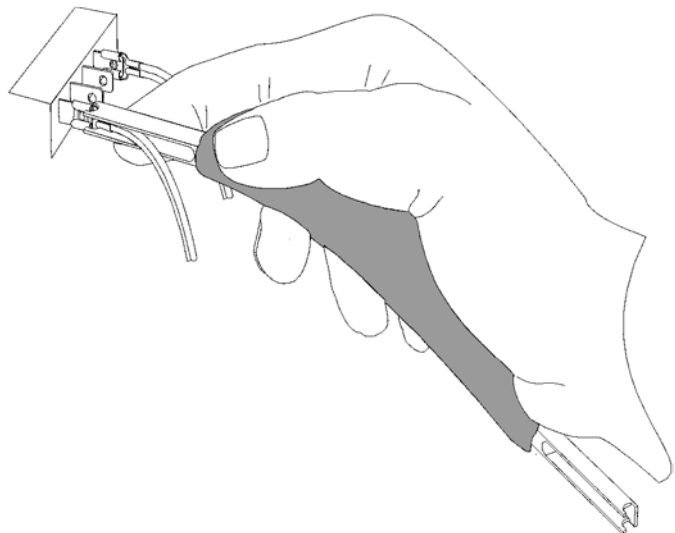

FIGURE 3
Ergonomically designed manual terminal-insertion tool.
Handle conforms to hand and ends are two sizes for different-sized terminals.

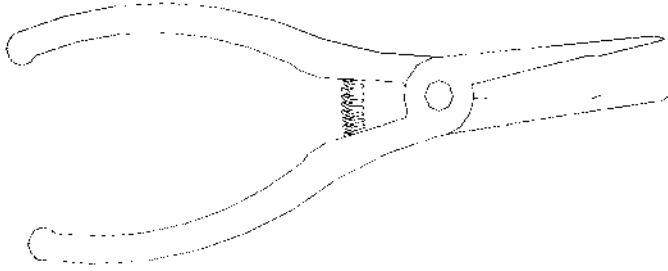

FIGURE 4

Properly designed pliers. Handle length is at least 4 inches and a spring return holds the handles open.

For More Information

To obtain more free information about controlling this hazard or for information about other occupational health

and safety issues:

- Call NIOSH at 1-800-35-NIOSH (1-800-356-4674), or

- Visit the NIOSH home page on the World Wide Web at <http://www.cdc.gov/niosh/homepage.html>.

A technical article on the subject has recently been published: *Room for Improvement Evident when It Comes to Ergonomics* [*Appliance Manufacturer* 45(12):261–264].

Acknowledgements

The principal contributors to this report were Cheryl F. Estill, James D. McGlothlin, Rosmarie T. Hagedorn, and Jerome P. Flesch. This Hazard Controls is DHHS (NIOSH) Publication No. 98-108.