

NBS/NIOSH

Volume I

PREPARED UNDER INTERAGENCY AGREEMENT NO. 82-06-M

DEVELOPMENT OF DRAFT CONSTRUCTION SAFETY STANDARDS FOR EXCAVATIONS

U.S. DEPARTMENT OF COMMERCE
NATIONAL BUREAU OF STANDARDS
NATIONAL ENGINEERING LABORATORY
CENTER FOR BUILDING TECHNOLOGY
GEOTECHNICAL ENGINEERING GROUP
STRUCTURES DIVISION
WASHINGTON, D.C. 20234

U.S. DEPARTMENT OF HEALTH AND HUMAN SERVICES
PUBLIC HEALTH SERVICE
CENTERS FOR DISEASE CONTROL
NATIONAL INSTITUTE FOR OCCUPATIONAL SAFETY AND HEALTH
DIVISION OF SAFETY RESEARCH
MORGANTOWN, WV 26505

IMPORTANT INFORMATION

Volume II of this report contains background information on the development of the draft standards. This information includes workshop summaries, workshop depositions, source documents and miscellaneous input and information contributed by workshop participants.

Volume II is for sale by the National Technical Information Service, Springfield, Virginia 22151.

DEVELOPMENT OF DRAFT CONSTRUCTION
SAFETY STANDARDS FOR EXCAVATIONS

VOLUME I

Prepared under Interagency Agreement No. 82-06-M

Felix Y. Yockel

U.S. DEPARTMENT OF COMMERCE
National Bureau of Standards
National Engineering Laboratory
Center for Building Technology
Geotechnical Engineering Group
Structures Division
Washington, DC 20234

and

Ronald L. Stanevich

U.S. DEPARTMENT OF HEALTH AND HUMAN SERVICES
Public Health Service
Centers for Disease Control
National Institute for Occupational Safety and Health
Division of Safety Research
Morgantown, WV 26505

May 1983

DISCLAIMER

Mention of company names or product does not constitute endorsement by the National Institute for Occupational Safety and Health or the National Bureau of Standards.

An NBS/NIOSH Publication

NBSIR 83-2693

DHHS (NIOSH) Publication No. 83-103

PREFACE

The Occupational Safety and Health Act of 1970, Section 22(c)(1)(d)(2) authorizes the Director of NIOSH to make recommendations concerning improved occupational safety and health standards. The purpose of this document is to recommend to OSHA revised, updated language for improving 29 CFR 1926 Subpart P on Excavations, Trenching, and Shoring.

The draft standard contained in the document represents a consolidation of technical research performed by the National Bureau of Standards (NBS) on excavations combined with analysis of the comments generated by discussions of the proposed revisions. The proposed revisions were discussed at five regional workshops at which representatives of interested parties such as organized labor, trade associations, academic institutions, and state and federal agencies participated. These workshops were held in Atlanta, GA, Boston, MA, Dallas, TX, Milwaukee, WI, and San Francisco, CA during the months of June and July of 1981.

We are pleased to acknowledge the contributions to this document made by staff of NIOSH, NBS, and the organizers of and participants in the workshops.

The views, conclusions and recommendations expressed in this document are not necessarily those of any particular reviewer, state, or federal agency. However, all comments, whether or not incorporated, were considered carefully and have been forwarded along with this document to OSHA.

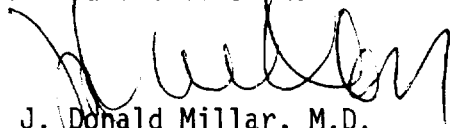

J. Donald Millar, M.D.
Assistant Surgeon General
Director, National Institute for
Occupational Safety and Health

ABSTRACT

Five regional industry workshops were held to discuss construction practice in excavations. The input document to the workshops contained suggested revisions to Subpart P of the Safety and Health Regulation for Construction¹ which were prepared by the National Bureau of Standards (NBS) and based on previously prepared recommendations for construction practice in excavations.² This report contains a copy of the workshop input document, workshop summaries and recommendations relating to the workshop input document.

Key words: braced excavations; construction; Federal regulations; retaining structures; safety; shoring; slope stability; soil classifications; soil pressures; standards, trenching.

¹ Federal Register, Vol. 39, No. 122, Safety and Health Regulations for Construction, Subpart P, Excavation, Trenching for Shoring, June 1974.

² Yokel, F. Y., Recommended Technical Provisions for Construction Practice in Shoring and Sloping of Trenches and Excavation, NBS Building Science Series 127, June 1980.

TABLE OF CONTENTS

	<u>Page</u>
ABSTRACT	iii
1. INTRODUCTION	1
2. ANALYSIS OF COMMENTS AND RECOMMENDATION	3
3. APPENDIX: Workshop Input Document	55

LIST OF FIGURES

	<u>Page</u>
Figure 1A. Zone of exposure	5
Figure 1. Effects of nearby foundation loads that must be determined by an engineer	18,19
Figure 2. Allowable configurations of sloped excavations (cases II, III and IV are for short-term excavations)	24,25
Figure 3. Determination of Adjusted Depth	28,29

LIST OF TABLES

	<u>Page</u>
Table 1. Soil Classification System for the Standard Practice	22,23
Table 4(a). Maximum Center-to-Center Spacing of Spaced Sheet piling Members	36

1. INTRODUCTION

Existing OSHA regulations governing excavations, trenching, and shoring practices in the construction industry (29 CFR 1926, Subpart P) were promulgated in 1971. In 1976, OSHA engaged NBS to review the technical provisions of the regulations in view of: 1) actual construction practice; and 2) the state of the knowledge in geotechnical and structural engineering.

Based on the results of that study, which was completed in 1980, a working draft of recommended revisions to Subpart P was prepared by NBS under sponsorship of OSHA and the National Institute for Occupational Safety and Health (NIOSH), and widely distributed throughout industry. In the summer of 1981, five regional industry workshops were conducted to discuss the recommendations. Industry response was encouraged, collected and evaluated carefully.

This report contains the input document to the workshops (the working draft), summaries of the workshop comments, and an analysis of the suggestions and commentary produced by the workshops. In combining NBS recommendations with industry input via the regional workshops, this document is intended to serve as groundwork for further OSHA development of recommended standards and as part of the record on which OSHA revision of Subpart P will be based. The report is also intended to serve industry as a resource document for the development of a voluntary consensus standard.

Section 2 contains a comparison of the text of the input document with comments and suggestions from the industry input, as well as resulting recommendations. The input document to the workshops is included as an appendix to Volume I of this report. Volume II of this report contains workshop summaries by the author, workshop proceedings prepared by the organizers, miscellaneous correspondence, prepared statements and background information.

2. ANALYSIS OF COMMENTS AND RECOMMENDATIONS

This section contains an analysis of industry-wide response to the recommendations contained in the workshop input document which is included as an appendix.

Regional industry workshops were held in June and July 1981, in: Atlanta, GA; Boston, MA; Dallas, TX; Milwaukee, WI; and San Francisco, CA. The workshops were jointly sponsored by AFL-CIO, AGC, the Association of Soil and Foundation Engineers (ASFE) and the National Utility Contractors Association (NUCA). Also, representatives of the shoring industry, government, and other interested groups, as well as interested individuals, participated in the workshops.

This section is laid out in a horizontal format which provides for the simultaneous presentation of four columns of information contained on facing pages. On the left hand page, the far left column contains the text of the input document. The next columns, also on the left hand page, includes any suggestions or comments which were produced in the industry workshops relating to the corresponding portion of the text. On the right hand page, left to right, are recommendations and suggestions made as a result of specific industry input, and a column containing an explanation of the recommendations.

SUBPART P - EXCAVATIONS AND SHORING

1926.650 - GENERAL PROTECTION REQUIREMENTS

(a) The regulations contain minimum requirements for the protection of workers in, and adjacent to, excavations against death and injury.

(a) It was suggested that this scope statement should be amplified to make clear that the regulations only apply when workers are exposed to mass movement of soil or rock. (Comments in Wisconsin workshop by F. Yokel--concern expressed that revised regulations may be enforced where they are not applicable, such as borrow pits.)

(b) Walkways, runways, and sidewalks shall be kept clear of excavated material or other obstructions and no sidewalks shall be undermined unless shored to carry a minimum live load of one hundred and twenty-five (125) pounds per square foot.

(c) If planks are used for raised walkways, runways, or sidewalks, they shall be laid parallel to the length of the walk and fastened together against displacement

(d) Planks shall be uniform in thickness and all exposed ends shall be provided with beveled cleats to prevent tripping.

(d) AGC of Kentucky suggest: "Planks shall be installed in a manner to reduce the probability of tripping.

(e) Raised walkways, runways, and sidewalks shall be provided with plank steps on strong stringers. Ramps, used in lieu of steps, shall be provided with cleats to insure a safe walkway surface.

- (a) The regulations contain minimum requirements for the protection of workers in, and adjacent to, excavations against death and injuries. The regulations for shoring, shielding and sloping apply to all excavations in which workers are exposed to effects of mass movement of soil or rock. The zone of exposure is defined in Figure 1A.

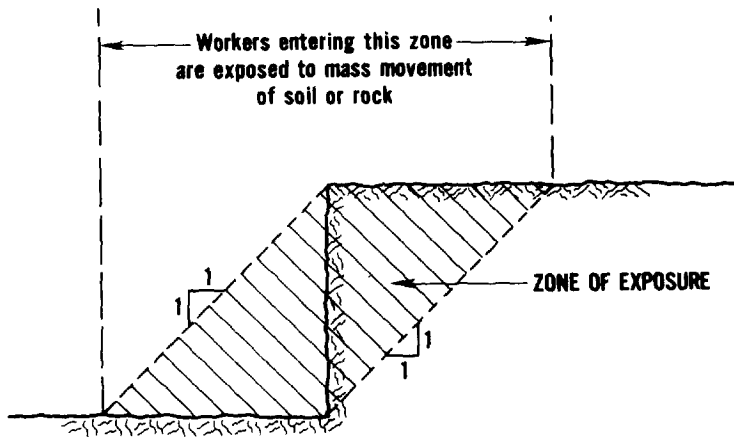

FIGURE 1A: ZONE OF EXPOSURE

- (a) This section contains a scope statement. It states that the regulations are minimum requirements, which may have to be exceeded in some instances. The definition of exposure is added in order to exempt excavations which pose no risk to workers from the regulations.

- (b) ... no sidewalk which supports human traffic while the excavation is in progress shall be... foot. Sidewalks which are undermined and not shored should be barricaded so they can not be used.

- (b) There may be sidewalks which are not in use until the excavation work is completed. Undermined sidewalks, even if not used, may be hazardous.

(c) NO CHANGE RECOMMENDED

- (d) A performance statement such as the one suggested would be desirable if it could be more precise. (i.e., the maximum allowable height of protrusions could be specified.)

(e) NO CHANGE RECOMMENDED

TEXT SUBMITTED TO WORKSHOP

COMMENTS

(f) All Employees shall be protected with personal protective equipment for the protection of the head, eyes, respiratory organs, hands, feet, and other parts of the body as set forth in Subpart Z of this part.

(g) Employees exposed to vehicular traffic shall be provided with and shall be instructed to wear warning vests marked with or made of reflectorized or high visibility material.

(h) Employees subjected to hazardous dusts, gases, fumes, mists, or atmospheres deficient in oxygen, shall be protected with approved respiratory protection as set forth in Subpart D of this part.

(i) No person shall be permitted under loads handled by power shovels, derricks, or hoists. Employees shall be required to stand away from any vehicle being loaded.

(j) A competent person shall inspect the excavation for evidence of possible cave-ins or slides, and indications of structural failure in members of the shoring system. If evidence of possible cave-ins or slides or structural failures is apparent, all work in the excavation shall cease until necessary precautions have been taken to safeguard employees.

The competent person shall conduct an overall inspection of the excavation and the ground adjacent to the excavation at least twice daily and shall conduct a special inspection after every rainstorm, penetration of water into the excavation, or other disturbance that could weaken the soil or the shoring system, and shall increase protection against slides and cave-ins if necessary.

Dewatering operations and equipment shall be monitored by a competent person to insure their proper operation and precautions shall be taken

(g) AGC of Kentucky: Need to define "exposed to vehicular traffic."

(h) The comment was made that "approved respiratory protection" is not necessarily the only means of protection. (F. Yokel - Boston workshop)

(i) It was noted that this provision forces a driver to leave the truck during loading (F. Yokel - Boston workshop). Some, but not all, equipment is listed (AFL-CIO).

(j) There was some discussion whether there should be a distinction between a competent and a qualified person (see F. Yokel memo on San Francisco workshop).

AFL-CIO recommended to substitute "see that all work in the excavation shall cease until necessary precautions have been taken to protect employees" or "increase protection against slides and cave-in's if necessary."

In the Wisconsin workshop (Hayden), the competent person is defined and the point is made that a competent person should always be at the site when work is in progress.

RECOMMENDATIONS/SUGGESTIONS

COMMENTARY

(f) NO CHANGE RECOMMENDED

(g) NO CHANGE RECOMMENDED

(h) NO CHANGE RECOMMENDED

(i) No person shall be permitted under loads handled by equipment.

(j) No employer shall cause or permit employees to work in, or adjacent to, an excavation until a competent person has determined that no recognizable conditions exist exposing them to injury from mass movement of soil or rock.

All excavation work and work in excavations shall at all times be under the supervision of a competent person.

Excavations, shoring systems and the ground adjacent to excavations shall be inspected by a competent person at least twice daily and after every rainstorm, penetration of water into the excavation, or other disturbance that could weaken the soil or the shoring system; and, if necessary, the competent person shall order all work in the excavation to cease until necessary precautions have been taken to protect employees.

Dewatering operations and equipment shall be monitored by a competent person to insure their proper

(i) The statement recommended is not tied to specific equipment. The specific reference to trucks is dropped since it would not permit a dump truck drive to remain in the truck during loading.

(j) The first paragraph is taken, in part, from the proposed California regulations and explicitly requires a safety determination by a competent person before anybody can work in, or adjacent to, an excavation.

The second paragraph is amended in accordance with AFL-CIO suggestions. The definition of a "competent person" will be changed in accordance with suggestions by the Wisconsin AGC (Hayden memo). A competent person's supervision is required for all excavation work under this provision.

to safeguard the workers in the excavation if dewatering equipment malfunctions.

1926.651-SPECIFIC EXCAVATION REQUIREMENTS

- (a) Prior to opening an excavation, efforts shall be made to determine whether underground installations, i.e., sewer, telephone, water fuel, electric lines, etc., will be encountered, and if so, where such underground installations are located. When the excavation approaches the estimated location of such an installation, the exact location shall be determined and when it is uncovered, proper supports shall be provided for the existing installation. Utility companies shall be contacted and advised of proposed work prior to the start of actual excavation.
- (b) Trees, boulders, and other surface encumbrances, located so as to create a hazard to employees involved in excavation work or in the vicinity thereof at any time during operations, shall be removed or made safe before excavating is begun.
- (c) (1) In excavations which employees may be required to enter, excavated or other material shall be effectively stored and retained at least 2 feet or more from the edge of the excavation.

(2) As an alternative to the clearance prescribed in subparagraph (1) of this paragraph, the employer may use effective barriers or other effective retaining devices in lieu thereof in order to prevent excavated or other materials from falling into the excavation.

- (a) Ohio Contractor Association recommended rewording. (Letter from Leonard Freed) Kodak Park Division commented that this section is appropriate in Subpart P, but should be dropped from Subpart S.
- (c) (1) AFL-CIO state that the edge clearance should be 3 ft.

Duke suggested that if the edge distance is too great, there is a danger that other materials may be piled up on the resulting shelf, actually increasing hazards. [This suggestion was erroneously addressed to paragraph 1926.652(6)(3).]

(2) AFL-CIO stated that "Other effective retaining devices" should be eliminated, and noted that their task force recommended extending tight sheeting 18 in. Rep. from the shoring industry - suggested eliminating projection of sheeting in Figure 3 of input document since this "is not always the method used to protect workers." Greater Milwaukee contractors consider the section redundant.

RECOMMENDATIONS/SUGGESTIONS

COMMENTARY

operation and workers shall leave the excavation or other precautions shall be taken to safeguard the workers if dewatering equipment malfunctions.

- (a) At the beginning of the paragraph, add the following sentence: "All known owners of underground utilities in the area involved shall be advised of the proposed work at least 48 working hours prior to the start of excavation work."

- (a) The sentence was taken in part from the proposed California Standard and is similar to, but more precise than, the opening sentence proposed by the Ohio Contractors Associated. The provision will assure that utility companies are advised of excavation work prior to its start.

- (b) NO CHANGE RECOMMENDED

- (c) (1) NO CHANGE RECOMMENDED

- (c) (1) AFL-CIO recommended to increase clearance to 3 ft., but no specific justification was presented for such a provision, which would increase right-of-way requirements. The AFL-CIO suggestion should be further studied before a decision is made.

(2) As an alternative to the clearance prescribed in subparagraph (1) of this paragraph, the employer may use protective barriers projecting at least 18 inches above the ground surface to prevent excavated or other materials from falling into the excavation.

(2) It appears that a "barrier" or a "retaining device" are one and the same.

Projecting the sheeting was suggested by AFL-CIO but considered hazardous by others. The decision about what kind of an effective barrier to use should be left to the contractor.

TEXT SUBMITTED TO AGENCY

COMMENTS

- (d) Diversion ditches, dikes or other suitable means shall be used to prevent surface water from entering an excavation and to provide adequate drainage of the area adjacent to the excavation. Water shall not be allowed to accumulate in an excavation, unless this condition is considered in the design and in the initial work plan and adequate provisions are made to protect workers.
- (e) If it is necessary to place or operate power shovels, derricks, trucks, materials, or other heavy objects on a level above and near an excavation, the side of the excavation shall be shored as necessary to resist the extra pressure due to such superimposed loads.
- (f) Blasting and the use of explosives shall be performed in accordance with subpart U of this part.
- (g) When mobile equipment is utilized or allowed adjacent to excavations, substantial stop logs or barricades shall be installed. If possible, the grade should be away from the excavation.
- (h) Adequate barrier physical protection shall be provided at all remotely located excavations. All walls, pits, shafts, etc., shall be barricaded or covered. Upon completion of exploration and similar operations, temporary walls, pits, shafts, etc., shall be backfilled.
- (i) If possible, dust conditions shall be kept to a minimum by the use of water, salt, calcium chloride, oil, or other means.
- (d) It was suggested in the San Francisco workshop to add "while work is in progress." (F. Yokel, S. F. memo)
- (e) Many comments noted that this section is redundant. In the San Francisco workshop, it was noted that methods other than shoring could be used. (F. Yokel, S. F. memo) Concern was expressed that this provision may be applied to backfilling operations.
- (f) A question was raised whether this section is necessary since it states the obvious.
- (g) Many workshop participants consider the use of stop logs impractical. The grading provision is advisory and, therefore, may not be appropriate in a regulation.
- (h) The statement was criticized as being imprecise. (Ohio Contractors Assoc., F. Yokel, S. F. memo) It was recommended to delete "remotely located." (F. Yokel, S. F. memo)
- (i) It was noted in many comments that this paragraph conflicts with EPA regulations.

RECOMMENDATIONS/SUGGESTIONS

COMMENTARY

(d) ...Water shall not be allowed to accumulate in an excavation while work is in progress, unless ...

(d) The qualification added would prevent an unnecessarily broad interpretation of this provision.

(e) It is recommended to eliminate this paragraph.

(e) "Surcharge" is adequately covered in 1926.652.

(f) NO CHANGE RECOMMENDED

(g) It is recommended to eliminate this paragraph.

(g) Stop logs are impractical. The second sentence contains a sound idea, but the phrase, "if possible" is too vague. Such a statement may be appropriate in a standard, but not in a regulation.

(h) Excavations at unattended work locations shall have adequate physical barrier protection or other means to prevent employees from falling into the excavation and mobile equipment from inadvertently entering the excavation. All walls, pits, shafts, etc., shall be barricaded or covered.

(h) The fact that an excavation is remotely located is less important than the fact that it is unattended. This more precise statement is in part taken from the proposed California regulations.

Upon completion of exploration and similar operations, temporary walls, pits, shafts, etc., shall be backfilled.

(i) It is recommended to eliminate this paragraph.

(i) Part of the regulation conflicts with EPA regulation. Also, a regulation containing the statement "if possible" is too vague.

TEXT SUBMITTED TO WORKSHOP

COMMENTS

- (j) In locations where oxygen deficiency or gaseous conditions are possible, air in the excavations shall be tested. Controls, as set forth in Subparts D and E of this part, shall be established to assure acceptable atmospheric conditions. When flammable gases are present, adequate ventilation shall be provided or sources of ignition shall be eliminated. Attended emergency rescue equipment, such as breathing apparatus, a safety harness and line, basket stretcher, etc., shall be readily available where adverse atmospheric conditions may exist or develop in an excavation.
- (k) Where employees or equipment are required or permitted to cross over excavations, walkways or bridges with standard guardrails shall be provided.
- (l) Where structural ramps are used for employees or equipment, they shall be designed and constructed by qualified persons in accordance with accepted engineering requirements.
- (m) All ladders used on excavation operations shall be in accordance with the requirements of Subpart L of this part.
- (n) Materials used for shoring, sheeting, and underpinning of structures adjacent to excavations shall not be damaged or weakened by corrosion, deterioration or prior use to an extent that will cause them to have a minimum strength less than that required in Section 1926.652 (b)(4)(ii).
- (o) Employees entering bell-bottom pier holes shall be protected by the installation of a removable-type casing of sufficient strength to resist shifting of the surrounding
- (j) It was suggested to spell out emergency procedures here, rather than referencing other regulations. (i.e., Texas memo, Braun and Root) It was also recommended to delete this paragraph, "in accordance with prior agreement with OSHA." (White, Texas workshop, Ohio Contractors Assoc.)
- (k) It was noted that this provision is not practical for small (shallow) trenches (Texas memo). It was also recommended to adopt the California approach (7 1/2 ft. or more, F. Yokel, S.F. memo).
- AGC of Kentucky suggested to eliminate this section because it is for long-term excavations.
- (l) AFL-CIO recommends: to eliminate "be designed and"
- (m) There was concern about ladders projecting above the trench (Texas workshop memo).
- (o) The wisdom of requiring a harness was questioned since sometimes other protection is safer (F. Yokel, Texas memo). AFL-CIO asked why straight

RECOMMENDATIONS/SUGGESTIONS

COMMENTARY

(j) Provisions should either be spelled out or paragraph deleted, as this is covered by other regulations.

(j) Neither duplication of regulations nor cross reference to other regulations are desirable.

(k) Trenches shall only be crossed where safe crossing have been provided. Walkways and bridges across excavated areas shall be provided with standard guardrails and toe boards when the depth of excavation exceeds ? feet (7 1/2 in California Standard).

(k) Walkways and bridges are not the only safe means for crossing excavations. There may be berms or access slopes. Guard rails should not be required for very shallow trenches. The wording is taken from the proposed California Standard. No justification was found for the 7 1/2 ft. height limit, even though it appears reasonable.

(l) drop "and constructed"....

(l) The intent here is to get proper engineering design. Since a "competent person" must be in the field, it is assumed they will be properly constructed.

(m) The need for this paragraph reference is questioned.

(m) Ladders are covered elsewhere.

(n) NO CHANGE RECOMMENDED

(o)above the bell. Adequate life saving equipment, suitable for instant rescue, shall be required for each employee entering the shaft. Employee personal protective equip-

(o) It is obvious that this section addresses itself specifically to belled piers since these require hand excavation. However, the term "partially cased" piers could also

TEXT SUBMITTED TO WORKSHOP

COMMENTS

earth. Such temporary protection shall be provided for the full depth of that part of each pier hole which is above the bell. A lifeline, suitable for instant rescue and securely fastened to a shoulder harness, shall be worn by each employee entering the shafts. This lifeline shall be individually manned and separate from any line used to remove materials excavated from the bell footing.

sided pier holes are not covered here.

Brown and Root noted that it is difficult to get men with harnesses out on a vertical pull. Proposed rewording.

(p) When employees are required to be in trenches 4 (5?) feet deep or more, an adequate means of exit, such as a ladder, steps or a negotiable slope shall be provided and located so as to require no more than 25 feet of lateral travel.

(p) Opinions of workshop participants were split on the issue of depth (5 ft or 4 ft). AFL-CIO favored 4 ft. Most, but not all, contractors and engineers favored 5 ft. It was suggested to allow the use of shoring as aid of exit and large pipes as shelter (Texas memo). It was suggested to allow escape to the center of wide excavations if escape routes are unobstructed (Kodak letter).

(q) Shoring shall follow the excavation as closely as practical in order to avoid long sections of unshored excavations.

(q) The comment was made that the section is confusing since shoring is not always needed (Duke, AGC-Kentucky). It was also suggested to drop this section.

(r) Members of the shoring system shall be installed in their proper position and secured to prevent failure.

(r) It was recommended to drop this provision (F. Yokel, Boston memo, Texas memo, AGC-Kentucky). The section also was called unclear. (AGC-Kentucky, Ohio Contractors Association)

(s) Portable trench boxes or sliding trench shields may be used for the protection of personnel in lieu of a shoring system or sloping. Where such trench boxes or shields are

(s) Efficiency Production and GME suggested to add: "As defined by accepted engineering practice".

RECOMMENDATIONS/SUGGESTIONS

ment should include, but not be limited to, harnesses, wristlets, or other devices acceptable to OSHA. Lifelines shall be individually manned and separate from any lines used to remove excavated material.

- (p) When employees are required to be in excavations 5 feet deep or more, an adequate means of exit such as a ladder, steps or a negotiable slope shall be provided and located so as to require no more than 25 feet of lateral travel. As an alternate to a means of exit to the top of the excavation, the following means of escape from mass movement of soil or rock are considered acceptable: unimpeded movement away from the excavation wall toward the center of the excavation if the width of the excavation measured at the top of the bank exceeds 3 times its depth; not more than 25 feet of unimpeded lateral travel to a large-diameter pipe or another safe structure which would not collapse, and the access to which would not be blocked as a result of a cave-in.
- (q) "As closely as practical" is very vague for a regulation. The paragraph, however, is appropriate for a standard. It is suggested to either drop this provision or change it to read, "Shoring, where needed, shall follow...."
- (r) Struts (cross braces) shall be secured to other members of the shoring system so they will stay in place when their preload is lost.
- (s) It is recommended to eliminate this paragraph.

COMMENTARY

be used. The section was revised in accordance with suggestions by Brown and Root.

- (p) The opinion on the limiting depth was split; however, it may be counterproductive to enforce the regulations for 4 ft deep trenches which would include most of the waterlines, and thereby considerably increase the volume of trenching work covered by these regulations.

In very wide excavations, escape to the center of the excavation would probably be safer than attempts to scale the bank. The same reasoning would also apply if a safe sheltered area is available on the bottom of the excavation.

- (r) This paragraph was too general to serve a useful purpose. However, it is important to "secure" struts, which have a tendency to fall out when the preload is lost.
- (s) Shoring, as well as shielding, systems are handled adequate in 1926.652. It is no longer necessary to use the concept of "equivalency" since Table P.2 is eliminated.

TEXT SUBMITTED TO WORKSHOP

COMMENTS

used they shall be designed, constructed, and maintained in a manner which will provide protection equivalent to that provided by the shoring required for the excavation.

- (t) Backfilling and removal of trench support shall progress together from the bottom of the trench. Struts shall be released slowly and, in unstable soils, ropes shall be used to pull out the jacks or braces from above after employees have cleared the trench.

- (t) Many workshop participants considered this section unwarranted because it is overly descriptive and could not be implemented with some systems (F. Yokel memos - Boston and Dallas, AGC-Kentucky).

1926.652-SPECIFIC SHORING, SHIELDING, AND SLOPING REQUIREMENTS

- (a) Acceptable Practice

- (a) Kodak suggested to use the terms "stable" and "unstable" rock, since almost all rock slopes that have been excavated are fractured.

- (1) The following excavations are exempt from shoring, shielding, and sloping requirements:

The opinions on the depth limit for the standard practice were split: AFL-CIO suggested 15 ft. The majority of AGC and ASFE, 24 ft. Some AGC and ASFE representatives, 20 ft.

- a. Excavations less than 5 ft deep, except when examination of the ground by a competent person indicates that hazardous ground movement may occur.

- b. Excavations in unfractured rock.

- (2) Excavations from 5 ft to 20 ft (24 ft ?) deep shall be shored, shielding, or sloped in accordance with the Standard Practice in Section 1926.652(b) with the following exceptions:

The opinions on "engineer" vs. "qualified person" were split. AFL-CIO wants the term "engineer." Most other participants suggested "qualified person," with an improved definition of the term. The suggestion was made that the "qualified person" should be required to submit calculations (F. Yokel, S. F. memo).

- a. If there is a deviation from the provisions of the Standard Practice, shoring, shielding, or sloping requirements must be determined by an engineer (a qualified person ?).

- b. An engineer shall determine the shoring, shielding, or sloping requirements whenever the bottom of a building foundation adjacent to the excavation which has not been secured by underpinning extends into the critical zone delineated in Figure 1.

AGC-St. Louis suggested that depth limits for standard practice should not apply to sloped excavations. Efficiency Construction suggested the term "qualified engineer." One important point was made in a joint report of the local sponsors of the Milwaukee workshop (Hayden), as well as by AFL-CIO (Mickle): Any OSHA standard should cover as many situations as possible with standard practice.

RECOMMENDATIONS/SUGGESTIONS

COMMENTARY

- (t) Removal of trench supports and backfilling shall be performed in a manner which will not expose workers to mass movement of soil or rock.

- (a) Acceptable Practice
- (1) The following excavations are exempt from shoring, shielding, and sloping requirements:
 - a. Excavations less than 5 ft deep, except when examination of the ground by a competent person indicates that hazardous ground movement may occur.
 - b. Excavations in stable rock.
- (2) Excavations from 5 ft to 24 ft deep in Type A and B soils and from 5 ft to 15 ft deep in Type C soils (see table 1) shall be shored, shielded or sloped in accordance with the Standard Practice in Section 1926.652(b) with the following exceptions:
 - a. If there is a deviation from the provisions of the Standard Practice, shoring, shielding, or sloping requirements must be determined by a qualified person.
 - b. An engineer shall determine the shoring, shielding, or sloping requirements whenever the bottom of a building foundation adjacent to the excavation which has not been secured by underpinning extends into the critical zone delineated in figure 1.

- (t) Careless or premature removal of shoring may expose workers to the effects of a cave-in. A descriptive section like the one originally proposed cannot work since different procedures are used for different shoring systems. Thus, a performance requirement is proposed.

- (a) The terms of stable and unstable rock are introduced as suggested by Kodak. This will help to resolve the difficulty arising from the definitions of "fractured rock." The definitions are modified accordingly.

A more rational approach is taken to the depth limit for standard practice. The greatest concern in selecting shoring for deep excavations without prior engineering analysis is not the lateral force against this shoring, but the possibility of a base failure, either because of inadequate shear strength of the soil, or because of a quick condition arising from hydraulic gradients. These concerns are associated with Type C soils and, therefore, a 15 ft depth limit is recommended for these soils. On the other hand, there is not much risk associated with a 24 ft limit for Type A and B soils, even though it is not likely that many contractors will use standard practice to this depth.

The controversy around the "qualified person" concept is primarily semantic. An attempt is made in 1956.652 to improve the definition of "qualified person."

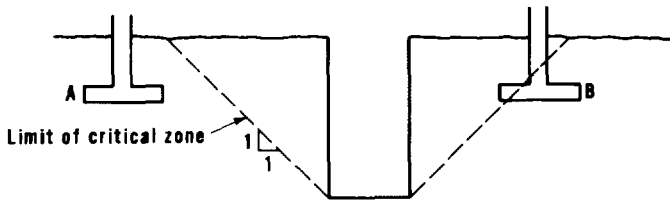

FOOTING A: Standard practice can be followed
FOOTING B: An engineer shall be consulted

Figure 1. Effects of nearby foundation loads that must be determined by an engineer

- (3) For all excavations deeper than 20 (24?) ft, except those in unfractured rock, an engineer (qualified person) shall determine the shoring, shielding, or sloping requirements.

(b) Standard Practice

(1) Scope

The Standard Practice provides a method by which field conditions are related to shoring, shielding, and sloping requirements.

The Standard Practice makes a distinction between short-term and long-term excavations (see definition in 1926.653 - 24 hours (7 days) is the division point).

- (b)(1) It was noted that in some regions there are local practices which have a long track record of successful application and an excellent safety record (see memoranda and letters on Wisconsin workshop). These practices do not always comply with the proposed Standard Practice (for instance, the struts in the Wisconsin practice cannot support the weight of a man - per F. Yokel memo). Introduction of the Standard Practice in such locations may actually increase accidents because workers have to be re-trained.

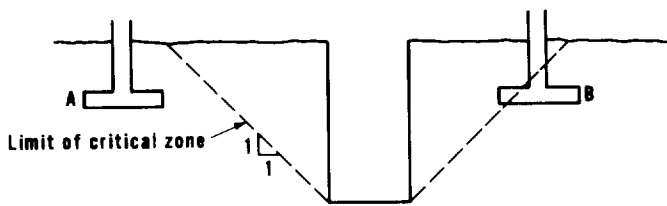

FOOTING A: Standard practice can be followed

FOOTING B: An engineer shall be consulted

Figure 1. Effects of nearby foundation loads that must be determined by an engineer

For all excavations deeper than 24 ft in Type A and B soils or 15 ft in Type C soils, except those in stable rock, a qualified person shall determine the shoring, shielding, or sloping requirements.

(b) Standard Practice

(1) Scope

The Standard Practice provides a method by which field conditions are related to shoring, shielding, and sloping requirements.

The Standard Practice makes a distinction between short-term and long-term excavations (see definition in 1926.653 - 3 days is the division point.)

Established regional practices can be used in lieu of the Standard Practice if they are approved by local authorities and have a proven record of at least 5 years of successful application. Such practices are subject to review and revocation if a serious accident occurs. Any change in such regional practices shall comply with the Standard Practice.

- (b)(1) Elimination of the distinction between short-term and long-term excavations, even though attractive from the point of view of simplicity, would force us to make the Standard Practice more conservative than present work practices. The 3-day division point seems a reasonable compromise.

The provision accommodating established regional practices is designed to minimize possible adverse impacts from the introduction of new regulations, while at the same time safeguarding the safety of the workplace. Additional field measurements particularly of loads acting on wales, could enable us to minimize the discrepancy between the Standard Practice and some established regional practices.

The provision that a change in an established regional practice must comply with the standard practice will safeguard against lateral load increases and failures, resulting from the replacement of shoring members used in the established practice by members made of different materials which may have the same working strength as the original member, but different stiffnesses and safety margins.

TEXT SUBMITTED TO WORKSHOP

COMMENTS

(2) Soil Classification

Soils are divided into three types: A, B, and C. For each soil type the "equivalent weight effect", w_e , to be used for the calculation of lateral soil pressure on shoring systems, and the maximum permissible sideslope for sloped excavations are stipulated. Table 1 provides guidance for the selection of the soil type.

Table 1

(3) Sloped Excavations

Sloped excavations shall not have sideslopes steeper than those stipulated in table 1. If there is any indication of general or local instability, slopes shall be cut back to the stable slope. The slope configurations shown in figure 2 can be used.

Figure 2--refer to page 24 for magnified print of figure 2.

(b)(2) In the California workshop, it was recommended to adopt the new soil classification recommended by CAL OSHA (F. Yokel, S. F. memo).

In the Boston workshop the suggestions was made to return to the Matrix classification originally proposed by NBS (Building Science Series 122).

Refer to page 22 for magnified print of table 1.

(3) See comments on table 1 and figure 2.

Figure 2

Different opinions were expressed regarding the bank next to the work area. Many contractors expressed the opinion that the bank should be increased to 4 ft (Dallas and Atlanta workshops, Kentucky AGC and others).

In the Dallas workshop, it was suggested by some contractors to increase the bank to 5 ft (workshop memo). AFL-CIO recommended to leave the allowable height at 3 ft. The point was made that if a large pipe is laid it would provide workers protection against collapse of the bank next to the work area.

AFL-CIO objected to case IV as too complicated for regulation--recommended to make it advisory.

RECOMMENDATIONS/SUGGESTIONS

COMMENTARY

(2) NO CHANGE RECOMMENDED

Refer to page 23 for magnified print of table 1.

(3) NO CHANGE RECOMMENDED

Figure 2--Refer to page 25 for magnified print of figure 2.

Figure 2

The revised sketch is a suggestion rather than a recommendation. It is recommended that industry try to reach agreement on the height of the allowable bank.

Reasons for increasing the bank to 4 ft would be that the safety risk is not substantially increased, while accommodating pipe bedding specifications presently used by many municipalities, etc. The suggested scheme would accommodate most specifications, while the original scheme would conflict with some.

Frequent situations of conflict between excavation safety regulations and job specifications could undermine the effectiveness of the regulations.

TEXT SUBMITTED TO AGENCY

Table 1. Soil Classification System for the Standard Practice

Soil Type	Description	w _e lb/ft ³	Steepest Allowable Slope hor.:vert. ^{b/}	
			Depth 12 ft. or less	Depth Greater than 12 ft.
A	Intact Hard	20 ^{a/}	3/4:1	1:1
B	Medium	40	3/4:1 ^{c/}	1 1/2:1
C	Saturated, Submerged or Soft	80	1 1/2:1	2:1

Notes:

1. Type A: Intact Hard Soils include stiff clays and clayey (cohesive) sands and gravels (hardpan, till) above the ground water table which have no fissures, weak layers, or inclined layers that dip toward the bank of the excavation as stipulated in Note 3. Stiff clays included have an unconfined compressive strength^{e/} q_u = 1.5 tsf or more. Intact hard soils subject to vibrations by heavy traffic, pile driving or similar effects are Type B.
2. Type B: Medium Soils are all soils which are not Type A or C.
3. Type C: a. Soft Soils include cohesive soils^{d/} with an unconfined compressive strength^{e/} of 0.5 tsf or less and soils that cannot stand on a slope of 3 hor.: 1 vert. without slumping (muck).

b. Saturated or Submerged Soils are assumed whenever water seeps into the excavation from the soil forming the bank; or water is retained by tight sheeting; or there is a possibility that the excavation may be entered by workers within 1 day after more than half of its depth was flooded and pumped out.
4. Layered Systems (two or more distinctly different soil or rock types or micaceous seams in rock) which dip toward the bank of the excavation with a slope of 4 hor.: 1 vert. or steeper are considered Type C. Layered soils are classified in accordance with the weakest layer.
5. Rock: Fractured rock shall be considered Type B when it is dry and Type C when it is submerged. Unfractured rock is exempt from shoring and sloping requirements.

^{a/} In long-term excavations "Intact Hard" soil is Type B soil.

^{b/} If there is any indication of general or local instability slopes shall be cut back to a slope which is at least 1/4 hor.:1 vert. flatter than the specified slope.

^{c/} In long-term excavations steepest allowable slope shall be 1:1.

^{d/} Cohesive soils are clays (fine grained) or soils with a high clay content which have cohesive strength. They do not crumble, can be excavated with vertical sideslopes, are plastic (can be molded into various shapes and rolled into threads) when moist and are hard to break up when dry.

^{e/} Unconfined compressive strength can be determined by undrained laboratory tests, field tests, or the following thumb penetration tests: stiff clays with an unconfined compressive strength of 1.5 tsf can be readily indented by the thumb nail. They can be indented by the thumb, but can be penetrated by the thumb only with very great difficulty. Cohesive soils with an unconfined compressive strength of less than 0.5 tsf can be easily penetrated several inches by the thumb and can be molded by light finger pressure. tsf=tons per square foot.

^{(b/} ...Slopes shall be cut back to the stable (flatter) slope? Change Table 1 to use 3/4:1 maximum slope as the only limitation?)

COMMENTS

It was suggested that 1/2:1 slope should be permitted (Wisconsin workshop, Kentucky AGC). Kentucky AGC also proposed a 5 ft bank next to the work area with a 1/2 in 1 slope for Type A soils and a 3 ft bank with a 3/4 in 1 slope for Type B soils.

It was noted by ASFE that the "Standard Practice is not conservative enough for slopes to be used blindly; thus, the "stable slope" concept must be maintained (Kleinfelder).

AFL-CIO strongly objected to the "stable slope" concept as being too vague. It was noted in the Texas workshop that some caliche formations will stand on a 1/4:1 slope (F. Yokel, Texas memo). It was noted that "vibrations" should be defined. It was stated that there is a conflict between the sloping requirements for Type C soils and the definition under 3. of soils that cannot stand on a 3:1 slope.

RECOMMENDATIONS/SUGGESTIONS

Table 1. Soil Classification System for the Standard Practice

Soil Type	Description	w _e lb/ft ³	Steepest Allowable Slope hor.:vert. ^{b/}	
			Depth 12 ft. or less	Depth Greater than 12 ft.
A	Intact Hard	20 ^{a/}	1/2:1	1/2:1
B	Medium	40	1/2:1 ^{c/}	3/4:1 ^{c/}
C	Saturated, Submerged or Soft	80	1:1	1 1/2:1

Notes:

1. Type A: Intact Hard Soils include stiff clays and clayey (cohesive) sands and gravels^{d/} (hardpan, till) above the ground water table which have no fissures, weak layers, or inclined layers that dip toward the bank of the excavation as stipulated in Note 3. Stiff clays included have an unconfined compressive strength^{e/} q_u = 1.5 tsf or more. Intact hard soils subject to vibrations by heavy traffic, pile driving or similar effects are Type B.
2. Type B: Medium Soils are all soils which are not Type A or C.
3. Type C: a. Soft Soils include cohesive soils^{d/} with an unconfined compressive strength^{e/} of 0.5 tsf or less and soils that cannot stand on a slope of 3 hor.: 1 vert. without slumping (muck).
 b. Saturated or Submerged Soils are assumed whenever water seeps into the excavation from the soil forming the bank; or water is retained by tight sheeting; or there is a possibility that the excavation may be entered by workers within 1 day after more than half of its depth was flooded and pumped out.
4. Layered Systems (two or more distinctly different soil or rock types or micaceous seams in rock) which dip toward the bank of the excavation with a slope of 4 hor.: 1 vert. or steeper are considered Type C. Layered soils are classified in accordance with the weakest layer.
5. Rock: Unstable rock shall be considered Type B when it is dry and Type C when it is submerged^d. Stable rock is exempt from shoring and sloping requirements.

a/ In long-term excavations "Intact Hard" soil is Type B soil.

b/ The steepest allowable slope is not necessarily safe in all conditions. A competent person shall determine the safe slope, and if there is any indication of general or local instability, slopes shall be cut back to a slope which is at least 1/4 hor.: 1 vert. flatter than the specified slope.

c/ In long-term excavations steepest allowable slope shall be 3/4:1 for depths 12 ft or less and 1:1 for depths greater than 12 ft.

d/ Cohesive soils are clays (fine grained) or soils with a high clay content which have cohesive strength. They do not crumble, can be excavated with vertical sideslopes, are plastic (can be molded into various shapes and rolled into threads) when moist and are hard to break up when dry.

e/ Unconfined compressive strength can be determined by undrained laboratory tests, field tests, or the following thumb penetration tests: stiff clays with an unconfined compressive strength of 1.5 tsf can be readily indented by the thumb nail. They can be indented by the thumb, but can be penetrated by the thumb only with very great difficulty. Cohesive soils with an unconfined compressive strength of less than 0.5 tsf can be easily penetrated several inches by the thumb and can be molded by light finger pressure. tsf=tons per square foot.

COMMENTARY

It is obvious from the workshop discussions that the maximum allowable slopes are too severe for many regions. Thus, these sloping requirements are relaxed. To offset possible hazards resulting from this relaxation, footnote b) was modified to explicitly charge the competent person on the job with the responsibility of selecting a safe slope. This approach is also in line with the ASFE comment that stipulates slopes cannot be used "blindly."

The terms "unstable" and "stable" are used in 5.

The statement on vibrations was not modified, even though it is realized that there may be some question whether a vibration warrants this consideration. It is possible, within the present state-of-the-art, to define vibration by velocity measurements; however, this approach seems too sophisticated for the excavation environment. In any case, heavy traffic and pile driving are specifically identified.

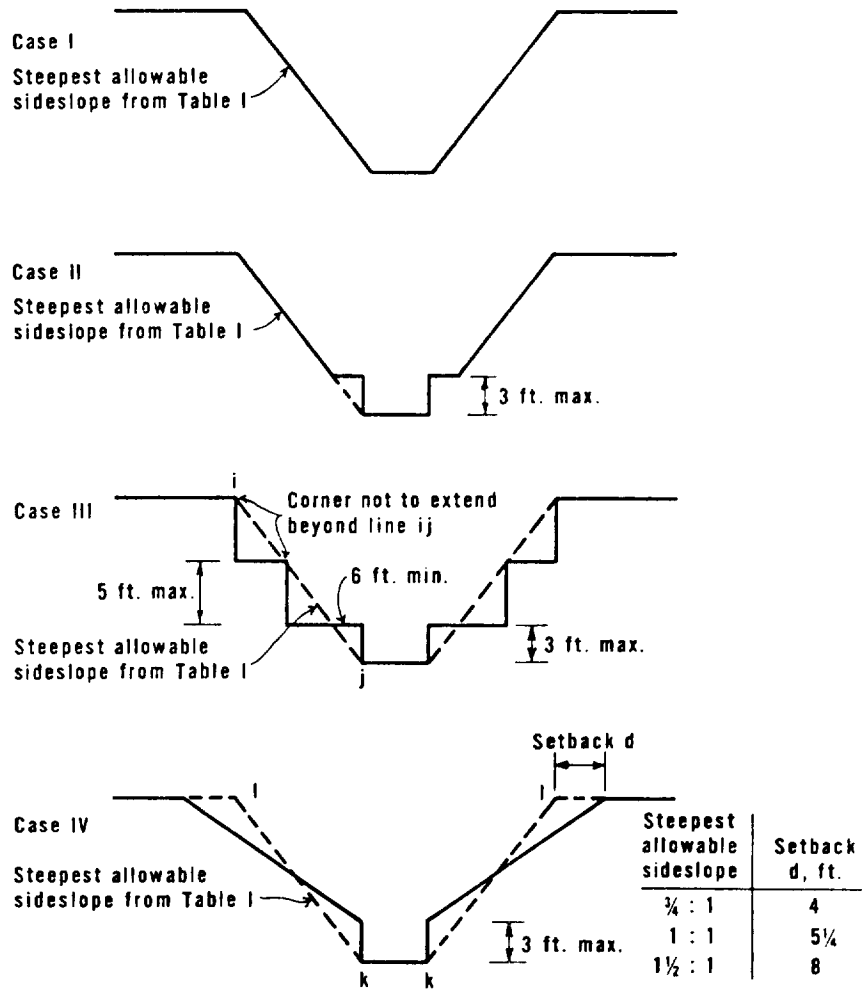

Case I - Simple slope

Case II - Compound slope with bench no more than 3 ft. high

Case III & IV - Configuration must meet following criteria:

1. No vertical bank to exceed 5 ft., the vertical bank adjacent to the work area not to exceed 3 ft.
2. Imaginary slopes ij and kl not to exceed steepest allowable sideslope from Table I

Figure 2. Allowable configurations of sloped excavations (cases II, III, and IV are for short-term excavations)

RECOMMENDATIONS/SUGGESTIONS

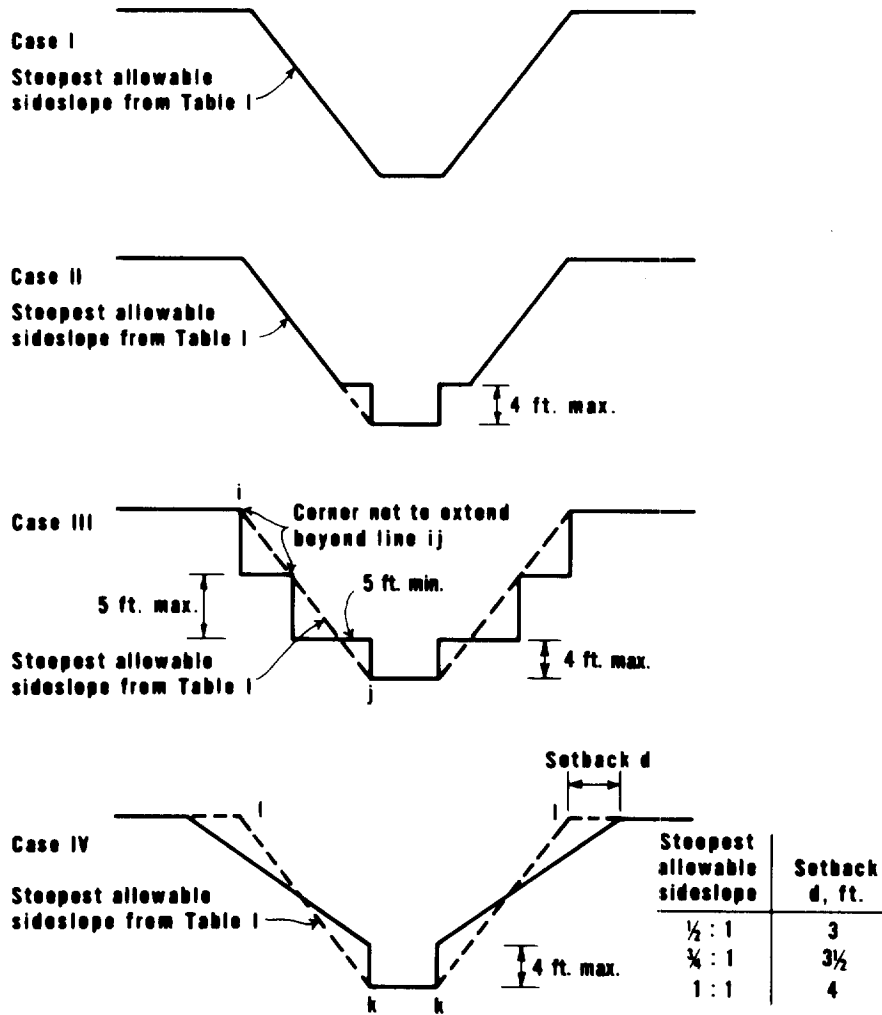

Case I - Simple slope

Case II - Compound slope with bench no more than 4 ft. high

Case III & IV - Configuration must meet following criteria:

1. No vertical bank to exceed 5 ft., the vertical bank adjacent to the work area not to exceed 4 ft.
2. Imaginary slopes ij and ki not to exceed steepest allowable sideslope from Table I

Figure 2. Allowable configurations of sloped excavations (cases II, III, and IV are for short-term excavations)

TEXT SUBMITTED TO WORKSHOP

COMMENTS

(4) Shored and Shielded Excavations

(4)(i) Many workshop participants observed that this section is complicated and perhaps difficult to implement. (F. Yokel, S. F. memo, Efficiency Production memo) AFL-CIO suggested to: 1) Increase surcharge in (4)(i) a. to 3 ft., 2) Keep (4)(2) b. and c. as a guideline.

(i) For the purpose of selecting shoring systems, trench shields, or trench boxes the depth of excavations shall be assumed greater than the actual depth in order to allow for spoil piles, construction equipment and sloping ground. This adjusted depth (H_e) shall be determined as follows:

- a. For ground sloping down from the supported or shielding excavation wall, level ground, or ground sloping up from the supported or shielded excavation wall with a slope less than 3 hor. in 1 vert. the Adjusted Depth (H_e) is the actual depth of the supported excavation wall (H) plus 2 ft (surcharge allowance). (See figure 3(a).)
- b. For ground sloping up from the supported or shielded excavation wall with a slope of 3 hor.:1 vert. or steeper the adjusted depth (H_e) is determined in accordance with table 2 and figure 3(b).
- c. For heavy equipment (20,000 lb or more) near the side of the supported or shielded excavation wall the additional depth shown in table 3 shall be added to the 2 ft. surcharge allowance stipulated in a. No additional depth needs to be added for equipment operating at a distance from the side of the excavation wall which is equal to, or larger than, the depth of the supported or shielded excavation (H).

RECOMMENDATIONS/SUGGESTIONS

COMMENTARY

(4)(i) NO CHANGE RECOMMENDED

(4)(i) Even though b. and c. require some skill, their application should not be too difficult for a competent person to handle. The alternative of a need to consult a qualified person who is not on the job is even less attractive. The AFL-CIO suggestion of increasing the surcharge requirement in a., and in return eliminating b. and c., would mean in practice that in case b., a backslope of maximum 4 ft. height (H_1 in figure 3b = 4 + 4 ft) could be allowed, and equipment of maximum 20,000 lb. With higher backslope and heavier equipment, an engineer (qualified person) would have to be consulted. If this is acceptable, OSHA could go that route.

TABLES 2 and 3 (Refer to appendix)

Tables 2 and 3 SEE COMMENTS ON 4(i)

Figure 3

Figure 3

It was suggested to eliminate the protrusion of shoring, as this is many times not used, and frequently not desirable as a means of protection against rolling or sliding objects (Bradberry).

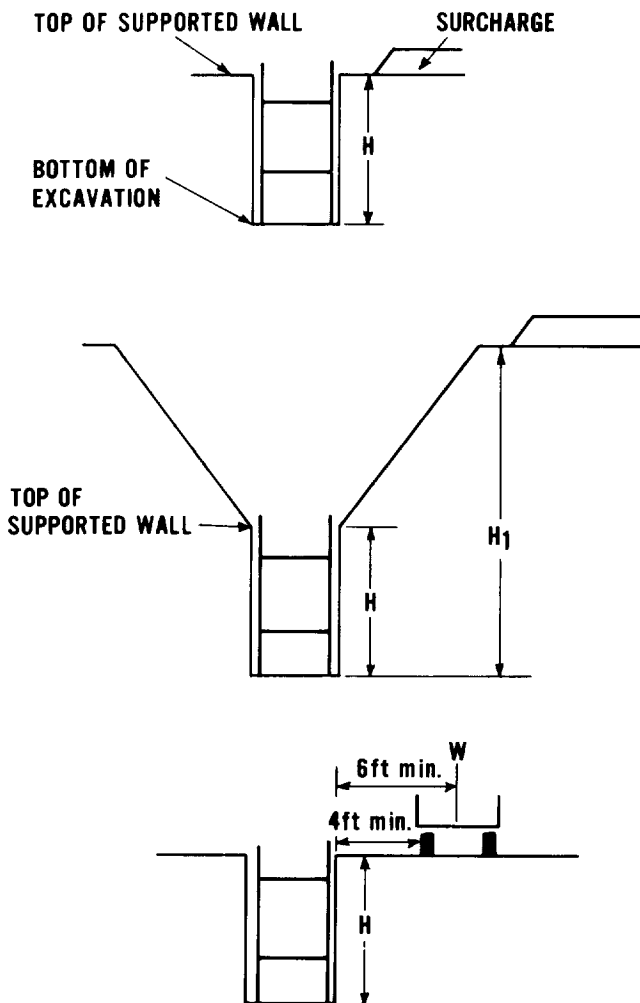

(a) AVERAGE CONDITION, TERRAIN NOT STEEPER THAN 3 hor : 1 vert
ADJUSTED DEPTH = $H+2ft$

(b) GROUND SLOPING TOWARD SUPPORTED WALL
ADJUSTED DEPTH IN ACCORDANCE WITH TABLE 2, BUT NOT MORE THAN H_1+2ft

(c) HEAVY EQUIPMENT LOADS
ADJUSTED DEPTH: ADD THE DEPTH FROM TABLE 3 TO THE 2ft SURCHARGE ALLOWANCE
ADJUSTED DEPTH = $H+2ft+H_w$
 H_w IS FROM TABLE 3

H = DEPTH OF SUPPORTED EXCAVATION

Figure 3. Determination of Adjusted Depth

TABLES 2 and 3 NO CHANGE RECOMMENDED

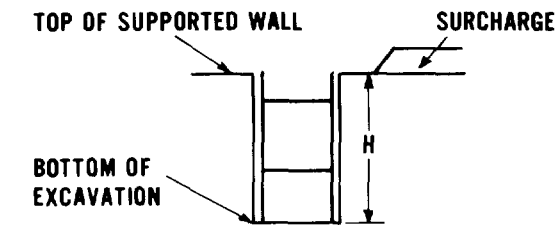

(a) AVERAGE CONDITION, TERRAIN NOT
STEEPER THAN 3 hor : 1 vert
ADJUSTED DEPTH = $H+2ft$

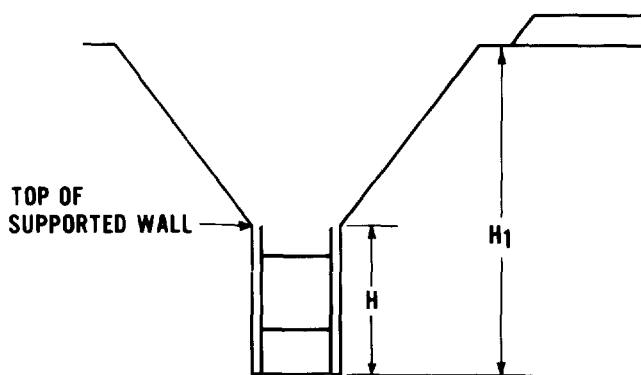

(b) GROUND SLOPING TOWARD
SUPPORTED WALL
ADJUSTED DEPTH IN ACCORDANCE
WITH TABLE 2, BUT NOT MORE
THAN H_1+2ft

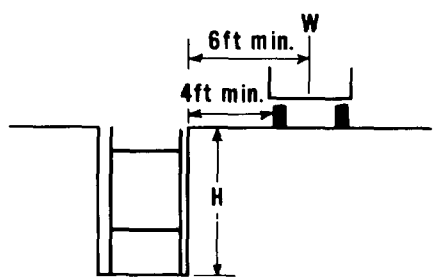

(c) HEAVY EQUIPMENT LOADS
ADJUSTED DEPTH: ADD THE
DEPTH FROM TABLE 3 TO THE
2ft SURCHARGE ALLOWANCE
ADJUSTED DEPTH = $H+2ft+H_w$
 H_w IS FROM TABLE 3

H = DEPTH OF SUPPORTED EXCAVATION

Figure 3. Determination of Adjusted Depth

TEXT SUBMITTED TO WORKSHOP

- (ii) Required strength of Shoring Systems, Trench Shields and Trench Boxes.

Shoring systems, trench shields and trench boxes shall have adequate strength to resist the following working loads:

- a. A uniformly distributed lateral pressure equal to the equivalent weight effect (w_e), in Table 1 times the Adjusted Depth (H_e) of the Excavation.
- b. A 240 lb gravity load distributed over a 1 ft length at the center of any strut (cross brace).
- c. A 240 ft-lb impact load acting toward the excavation on the walls of trench shields and trench boxes.

Loads a. and b. shall be assumed to act simultaneously. Only trench shields and trench boxes need to resist load c.

Shoring systems shall be designed in accordance with accepted engineering practices. A 33 percent increase in allowable working stresses or an equivalent strength reduction shall be acceptable for shoring systems, trench shields, and trench boxes used in short-term excavations.

COMMENTS

- (ii) Many workshop participants commented that this section should be at the end of the text since it addresses itself to people who pre-design shoring systems and not to the man in the field.

AFL-CIO noted that in accordance with their task force recommendation, the gravity load under b. should be increased to 500 lb. They also noted that the impact load requirement is not clear.

Efficiency Production, in behalf of the trench box industry, requested that under a. a triangular (hydrostatic type) pressure distribution be permitted. However, another trench box manufacturer said that he agrees with our recommendation. The justification for the 33 percent overload for short-term excavation was questioned (F. Yokel, Boston memo).

RECOMMENDATIONS/SUGGESTIONS

COMMENTARY

- (ii) Move to end of 1926.652. Amend text as follows:

Required strength of Shoring Systems, Trench Shields, and Trench Boxes and used with the Standard Practice

Shoring systems, trench shields, and trench boxes shall have adequate strength to resist the following working loads:

- a. A uniformly distributed lateral pressure equal to the equivalent weight effect (w_e) in table 1 times the Adjusted Depth (H_e) of the excavation.
- b. A 240 lb gravity load distributed over a 1 ft length at the center of any strut (cross brace).
- c. A 240 ft-lb impact load^{a/} acting toward the excavation at any point on the walls of trench shields and trench boxes.

Loads a. and b. shall be assumed to act simultaneously. Only trench shields and trench boxes need to resist load c.

Shoring systems shall be designed in accordance with accepted engineering practices. A 33 percent increase in allowable working stresses or an equivalent strength reduction shall be acceptable for shoring systems, trench shields, or trench boxes used in short-term excavations.

Struts shall be designed to resist the full lateral pressure stipulated in (ii)a wales 80 percent of the lateral pressure, and sheeting 67 percent of the lateral pressure.

- a/ The load shall be applied by a 60 lb. sand-filled leather bag (ASTM E72-77).

- (ii) The section cannot be eliminated since this would make the Standard Practice meaningless. It should, however, be separated from the rest of the text since it is addressed to shoring and shield manufacturers and engineers.

It is not recommended to increase the gravity load since this is considered dangerous. Contractors and workers will assume that struts can support loads and load their struts. Such a situation is likely to get out of hand. As it is, workers should be prohibited from loading struts or climbing on struts, and vertical load capacity is provided strictly for emergencies.

It is specifically noted that this section is applied for pre-designed systems used with the Standard Practice. An engineer need not follow the Standard Practice, and thus is also not bound by this section.

The impact loading is more precisely defined in this revision, and provisions are made for load reductions for wales and sheeting.

It should be noted that with the 33 percent load reduction, the Standard Practice will yield struts roughly equal to those presently used in empirical practice. Elimination of the load reduction would make the Standard Practice more conservative than empirical practice.

TEXT SUBMITTED TO WORKSHOP

COMMENTS

(iii) Selection of Shoring System, Trench Shields, and Trench Boxes

Shoring systems, trench shields, and trench boxes shall be selected in the field on the basis of Soil Type (Table 1), Adjusted Depth (Section 1926.652(b)(4)(i)) and a determination whether the excavation is long-term or short-term in the following manner:

- a. Trench shields, trench boxes, pre-fabricated strut-wale assemblies and other pre-fabricated assemblies shall be rated for the maximum Adjusted Depths in Type A, B, and C soils in which they can be used, and selected accordingly.
- b. Hydraulic shores or other pre-fabricated sub-assemblies or members of shoring systems shall be rated for allowable working loads and selected with the aid of the charts in the guidelines supplementing Subpart P, or selected directly from special charts prepared by the manufacturer.
- c. Timber shoring shall be selected with the aid of charts in the guidelines supplementing Subpart P or from special charts prepared by an engineer (qualified person).
- d. Any other shoring system can be pre-designed and rated by an engineer (qualified person) and selected on the basis of soil type and equivalent depth from charts prepared for this purpose.

(iii) Efficiency Production suggested to state in the second paragraph simply: Shoring systems and trench shields shall be selected in the field in accordance with accepted engineering practices. They also suggested to drop the word, "Adjusted" in a., and "qualified person" in c. AFL-CIO recommended actually bringing charts for hydraulic shoring or other pre-designed assemblies into the Standard Practice. They also noted that timber shoring should be in the guidelines and selected by an engineer.

The Wisconsin workshop memo noted that timber shoring should be so designed that all members (struts and wales) are the same size.

George Bradberry stated that the examples given should be further pursued in the regulations. He further elaborated on his written statement by stating that descriptive tables for prefabricated assemblies, which comply with the Standard Practice, should be provided in an addendum to the regulations.

RECOMMENDATIONS/SUGGESTIONS

COMMENTARY

- (iii) Selection of pre-designed shoring system, trench shields, and trench boxes to be used with the Standard Practice.
- Shoring systems, trench shields, and trench boxes shall be selected in the field on the basis of Soil Type, (Table 1), Adjusted Depth, [Section 1926.652(b)(4)(i)], and a determination whether the excavation is long-term or short-term in the following manner:
- a. Any shoring system which is intended for a specific project can be pre-designed by a qualified person and selected in the field on the basis of soil type and equivalent depth from charts or other instructions prepared for this purpose.
 - b. Trench shields, trench boxes, pre-fabricated strut-wale assemblies and other pre-fabricated assemblies shall be rated by an engineer for the maximum Adjusted Depths in Type A, B, and C soils in which they can be used and selected accordingly.
 - c. Hydraulic shores or other pre-fabricated subassemblies or members of shoring systems shall be rated by an engineer for allowable working loads and selected with the aid of the charts supplementing Subpart P, or selected directly from special charts prepared by an engineer in behalf of the manufacturer.
 - d. Timber shoring shall be selected with the aid of charts supplementing Subpart P or from special charts prepared by an engineer.

In addition, it is recommended to have an addendum to Subpart P which will aid in the selection of shoring (similar to table P-2, but covering much more than timber shoring and containing figures, as well as tables and charts).

- (iii) The section title was re-written to specifically apply to systems used with the Standard Practice.
- a. is for the case where a contractor pre-designs his own shoring systems (site or company specific). In this case, the term "qualified person" is used, and it is the contractor's responsibility that the system be designed to resist the stipulated minimum loads.
 - b. is intended for trench box manufacturers and requires rating of the trench boxes by an engineer either generically for standard box types manufactured, or, if the need arises, for a specific case.
 - c. leaves two options--the use of generic charts in a supplement to subpart P, to be used with shoring rated by an engineer for specific load capacity, or charts prepared by an engineer for the manufacturer.
 - d. leaves also two choices--in this case, a state or municipality may want their own chart, or charts from the subpart P supplement may be used.

In lieu of b., c., and d., a contractor may design his own system under a.

An addendum, rather than a guideline is proposed for specific charts and figures that will help personnel in the selection of shoring.

TEXT SUBMITTED TO WORKSHOP

COMMENTS

(5) Special Provisions

(i) Intersecting Trenches

When two trenches intersect and one trench is shored, the intersecting trench shall also be shored from the intersection of the two trench walls to a distance of not less than its depth.

(i) In the S. F. workshop, it was noted that there should be an option to block the intersecting trench. Ohio Contractors Association noted that this cannot always be done.

(ii) Sloping Ground

If the ground behind an excavation wall slopes up from the excavation wall and the ground slope exceeds 3 hor. in 1 vert. workers in the excavation must be protected against objects rolling or sliding from the sloped ground. This can be accomplished by projecting the sheeting at least 18 inches above the ground surface or by a specially constructed protective toeboard. If spaced sheeting is used provisions shall be made to close the gaps between projecting sheeting members. (Workers in excavations must be protected against rolling or sliding objects.)

(ii) AFL-CIO strongly endorsed this paragraph and objected to the performance statement in parentheses.

George Bradberry noted elsewhere that vertical shoring members should not be shown as protruding above the top of the excavation since this is often not done.

Many contractors supported the performance statement.

(iii) Excavation Below the Bottom of Sheeting, Trench Shields, or Trench Boxes

Excavation up to 2 ft (3 ft ?) below the bottom of sheeting, trench shields or trench boxes is permitted in short-term excavations provided that:

- a. No soil movement below the bottom of the sheeting, trench shield, or trench box is evident, and
- b. The forces acting on the bracing, trench shield, or trench box are calculated for the full depth of the excavation, and the lowest wales and struts are designed to resist the forces that would result if the sheeting would be projecting to the bottom of the excavation.

(iii) Most contractors supported the 3 ft option (in parentheses); however, participants in the San Francisco workshop, including contractors and ASFE, were in favor of limiting the excavation below the bottom of sheeting to 2 ft.

In the Boston workshop, the ASFE representative suggested to limit the length over which this type of excavation is allowed.

Kodak noted that many times this has to be performed on the bottom of long-term excavations for the purpose of installing utilities. Thus, they proposed to put "short-term" in the beginning of the sentence. The term, "soil movement," was criticized as being too vague.

RECOMMENDATIONS/SUGGESTIONS

COMMENTARY

- (5) Special Provisions
- (i) Intersecting Trenches
- When two trenches intersect and only one trench is shored, adequate support must be provided for the struts near the unshored trench. This can be accomplished by shoring the intersecting unshored trench from the intersection of the two trench walls to a distance of not less than its depth.
- (ii) Sloping Ground
- If the ground behind an excavation wall slopes up from the excavation wall and the ground slope exceeds 3 hor. in 1 vert. workers in the excavation must be protected against objects rolling or sliding from the sloped ground. This can be accomplished by a protective barrier projecting at least 18 inches above the ground surface.
- (iii) Short-term Excavation Below the Bottom of Sheet piling, Trench Shields, or Trench Boxes
- Short-term excavation up to 3 ft below the bottom of sheet piling, trench shields, or trench boxes is permitted provided that:
- a. There is no evidence of soil instability below the bottom of the sheet piling, trench shield, or trench box; and
- b. The forces acting on the bracing, trench shield, or trench box are calculated for the full depth of the excavation, and the lowest walers and struts are designed to resist the forces that would result if the sheet piling would be projecting to the bottom of the excavation.
- (5)
- (i) The intent of this provision is to prevent a shear failure caused by the thrust exerted by struts against the excavation wall. Blocking off the intersecting trench will not alleviate this problem. The paragraph was re-written to give the option to use other methods for securing the struts near the unshored trench.
- (ii) A good case for a protective barrier, at least 18 in high, has been made by the AFL-CIO task force. It is, however, not considered prudent to encourage projections of vertical shoring member. If such members are hit by a heavy rolling object, the impact could trigger a cavein.
- (iii) The wording was changed to also permit such short-term excavation within a long-term excavation and also to make sure that the excavation below the sheet piling be short term.
- The term, "soil movement," was removed since this term was considered confusing in past court cases.
- The permitted excavation depth was increased to 3 ft., since this is considered adequate for a wide range of construction situations without being excessively risky. A 2 ft. clearance would be inadequate even for small-diameter pipe.

TEXT SUBMITTED TO WORKSHOP

COMMENTS

- (iv) Maximum Spacing of Spaced Sheeting^{a/}
Maximum allowable spacing of spaced sheeting shall be in accordance with table 4(a) or (b) whichever controls.

- (iv) It was suggested to eliminate table 4(a) since it is sufficient to specify "clear spacing."

Table 4(a) Maximum Center-to-Center Spacing^{b/} of Spaced Sheeting Members

Soil Type	Depth of Excavation		
	5 ft- 10 ft	10 ft- 15 ft	15 ft- 20 ft
A	8 ft	6 ft	4 ft
B	4 ft	4 ft	3 ft
C	Tight Sheeting Required		

Table 4(b) Maximum Clear Spacing^{b/} of Spaced Sheeting Members

Soil Type	Depth of Excavation		
	5 ft- 10 ft	10 ft- 15 ft	15 ft- 20 ft
A	7.5 ft	5.5 ft	2 ft
B	4 ft	2 ft	1 ft
C	Tight Sheeting Required		

a/ If there is an indication of spalling the spacing must be reduced to a spacing that will prevent spalling.

b/ Refer to figure 4, page __.

RECOMMENDATIONS/SUGGESTIONS

(iv) NO CHANGE RECOMENDED

COMMENTARY

(iv) If center to center spacing requirements are eliminated, the arching characteristics of the unsupported excavation wall may change unless the stiffness of the spaced supports is specified. This may be difficult to do in practice.

The tables themselves reflect successful empirical practice.

1926.653 DEFINITIONS APPLICABLE
TO THIS SUBPART

- (a) "Accepted engineering requirements (or practices)." Those requirements or practices which are compatible with standards required by a registered architect, a registered profession engineer, or other duly licensed or recognized authority. Guidance for accepted engineering practices pertaining to excavation safety is provided in the guidelines supplementing Subpart P.
- (a) It was suggested by many participants to remove the word, "registered architect," since architects are not normally involved in excavation work. The question was raised whether the last sentence is still a part of the definition (maybe there will be no guidelines).
- (b) Acceptable Practice is a practice which meets the minimum requirements in Section 1926.652(a).
- (c) Adjusted Depth is the actual depth from the bottom of the excavation to the top of the supported excavation wall plus an additional depth to allow for surcharge, sloping ground, or heavy equipment as stipulated in Section 1926.652(b)(4)(i).
- (d) Allowable Working Stresses are allowable stresses determined in accordance with accepted engineering practices.
- (e) Belled Excavation is a part of a shaft or footing excavation, usually near the bottom and bell-shaped; i.e., an enlargement of the cross section above.
- (f) Clear Spacing of sheeting members is the distance between the edges of sheeting members over which the soil is unsupported (see figure 4).
- (g) Competent Person means one who is capable of identifying existing and predictable hazards in the surroundings or working conditions which are unsanitary, hazardous, or dangerous to employees, and who has authorization to take prompt corrective measures to eliminate them.
- (g) In the San Francisco workshop, it was proposed to eliminate the "competent person" and have only a "qualified person".
- It was noted that a competent person should always be at the excavation site (F. Yokel, Atlanta memo; Bradberry).

RECOMMENDATIONS/SUGGESTIONS

COMMENTARY

(a) "Accepted engineering requirements (or practices)" Those requirements or practices which are compatible with standards required by a registered professional engineer, or other duly licensed or recognized authority. Guidance for accepted engineering practices pertaining to excavation safety is provided in the guidelines supplementing Subpart P.

(b) NO CHANGE RECOMMENDED

(c) NO CHANGE RECOMMENDED

(d) NO CHANGE RECOMMENDED

(e) NO CHANGE RECOMMENDED

(f) NO CHANGE RECOMMENDED

(g) Competent Person means one who is capable of identifying existing and predictable hazards in the surroundings or working conditions which are unsanitary, hazardous, or dangerous to employees, and who has authorization to take prompt corrective measures to eliminate them.

In excavation work, the competent person is one who has the knowledge and experience necessary to apply the Standard Practice for sloping

(g) The existing definition appears adequate, except that specific knowledge of the Standard Practice should be required. The competent person should also recognize conditions which are not covered by the Standard Practice and, therefore, require the judgment of a qualified person or an engineer.

- (h) Engineer is a registered professional engineer.
 - (i) Equivalent Weight Effects (w_e) is the weight effect stipulated in table 1 which is used to calculate pressures on shoring systems.
 - (j) Excavation is any manmade cavity or depression in the earth's surface except as noted, including its sides, walls, or faces, formed by earth removal and producing unsupported earth conditions by reasons of excavation. Excavations do not include tunnels and shafts, caissons and cofferdams covered by Subpart S of the Safety and Health Regulations for Construction.
 - (k) Excavation Wall is the side of an excavation, rising from the bottom of the excavation to the ground surface.
 - (l) Fractured Rock is rock which could spall or crumble when excavated with vertical slopes. Fractured rock slopes secured against mass movement and spalling by rock bolts, netting, or other means approved by a qualified person are considered stable (equal to unfractured rock).
- (h) It was recommended that registration should not be required.
 - (j) Kodak recommended to either state that excavations include trenches, or use separate trench definition.
 - (l) Kodak recommended to use terms of "stable" and "unstable" rock. It was noted that the definition lacks precision, and that all rock that was excavated was also "fractured" (F. Yokel, Atlanta workshop). It was suggested that a "competent," rather than a "qualified," person determine if slope is secured.

RECOMMENDATIONS/SUGGESTIONS

COMMENTARY

and shoring, and to recognize conditions where a qualified person or an engineer must be consulted.

(h) NO CHANGE RECOMMENDED

(h) If the concept of a "qualified person" is retained, an "engineer" should always be a registered professional.

(i) NO CHANGE RECOMMENDED

(j) Excavation is any manmade cavity or depression in the earth's surface except as noted, including its sides, walls, or faces, formed by earth removal and producing unsupported earth conditions by reason of excavation. Excavations do not include tunnels and shafts, caissons and cofferdams covered by Subpart S of the Safety and Health Regulations for Construction.

(j) Since many contractors view trenches separately from excavations, it is important to emphasize that trenches are included in excavations.

Excavations include trenches commonly used for the installation of piping and other utilities.

(k) NO CHANGE RECOMMENDED

(l) Unstable Rock is rock which could spall or crumble when not supported by shoring. Unstable rock slopes secured against mass movement and spalling by rock bolts, netting, or other means approved by a qualified person, are considered stable.

(l) The term, "unstable rock," seems more appropriate since any rock that is excavated has been fractured. The phrase, "excavated with vertical slope," was dropped since there is no reason why a steeper slope than that stipulated in table 1, say 1/4:1, could not be permitted as long as there is no danger of spalling or rock slides, even if a stable vertical excavation was impossible. The requirement for approval by a qualified person is important since, in many instances, consideration must be given to geological features which a competent foreman may not understand.

TEXT SUBMITTED TO WORKSHOP

COMMENTS

(m) Long-term Excavations are excavations which are open for more than 24 hours (7 days).

(m) Opinions on the length of time for an excavation to become long term differed. AFL-CIO supported the original 24 hours. Some contractors supported 7 days. Contractors in Texas and Atlanta workshops, as well as trench box manufacturers, suggested to drop the distinction between short-term and long-term. Many participants suggested that 3-4 days may be a good dividing line so that excavations which are open over the weekend don't become "long term." It was also noted that in many instances a trench may be covered in several hours, but man holes stay open for a week or more.

It was also noted that in arid regions there is no rationale for distinguishing between long-term and short-term excavations.

(n) Mud Sills are wales which are installed at the level of the bottom of the excavation wall.

(o) Negotiable Slope is a slope on which a person can egress from or ingress to an excavation.

(o) AFL-CIO suggested 1 1/2:1 slope; Efficiency Production suggested to add "with relative speed."

(p) Qualified Person means one who, by possession of a recognized degree, certificate, or professional standing, has successfully demonstrated his ability to solve or resolve problems relating to the subject matter, the work, or the project.

(p) AFL-CIO objected to the use of a "qualified person" in matters relating to the design of shoring unless that person is a registered engineer. They are worried about identifying who is qualified. ASFE favored the concept of a qualified person since

RECOMMENDATIONS/SUGGESTIONS

COMMENTARY

- (m) Long-term Excavations are excavations which are open for more than 72 hours.
- (n) NO CHANGE RECOMMENDED
- (o) Negotiable Slope is a slope on which any person working in the excavation can readily egress from or ingress to an excavation.
- (p) Qualified Person is a person designated by the employer, preferably a registered professional engineer, who is familiar with the operation to be performed and the hazards involved and who has the necessary training, knowledge and experience to perform the engineering analysis and exercise
- (m) There are many parameters which affect slope stability as a function of time. These include: fissuring caused by lateral expansion (removal of restraint); change in soil moisture content; erosion) effects of vibration and disturbance an seepage. To find a common denominator for all conditions is impossible. On the other hand, some of the proposed provisions would have to be much more conservative (slope, lateral pressure for medium clays, allowable stresses in shoring) when there is no time limit on their application. Three days seems a reasonable time span for a federal standard. Individual states or regions may revise this down or up, considering local conditions.
- (o) Since there are no research data on negotiable slope at the present time, it is suggested to keep the performance statement. "With relative speed" is too vague as a requirement. "Any" person "working in the excavation" was added for cases where egress may require special physical skill which not everybody possesses. It is conceivable that an employer could be required to demonstrate that his men can egress. Alternately, research could be performed to determine how flat a slope has to be before it is negotiable. There is no doubt that the 1 1/2:1 slope suggested by AFL-CIO is negotiable; however, such flat slopes are normally not used in construction.
- (p) Since the qualified person has to deal with situations which fall outside the Standard Practice, he must have the capability to determine the stability of excavation slopes and the adequacy of shoring or shielding systems. It should essentially be the responsibility of

the contractor has primary responsibility.

Wisconsin OSHA objected to a "qualified person" for depths beyond the Standard Practice and noted that a professional engineer should be required.

Metropolitan St. Louis Sewer District suggested that "competent" and "qualified" persons be used for protection of the safety of personnel, and registered engineers be used to protect adjacent structures against excessive settlements.

California AGC suggested that the "qualified person" should be designated by the contractor (F. Yokel, S. F. memo), ASFE (California) suggested that perhaps design calculations should be required.

- (q) Safety Margin is any measure of excess strength over that required to resist the working loads.
- (r) Sheeting is composed of members of the shoring system which are in direct contact with the soil in the supported bank.
- (s) Shoring Systems are structural systems supporting the bank of an excavation.
- (t) Short-Term Excavations are excavations which are open for 24 hours (7 days) or less.
- (u) Sides, Walls, or Faces are the vertical or inclined earth surfaces formed as a result of excavation work.
- (v) Slope is an incline expressed as a ratio of horizontal distance to vertical rise.
- (w) Spaced Sheeting is sheeting in which the members bearing against the excavation wall are spaced (see figure 6).
- (x) Spalling is the continuous flaking and falling of soil or rock from an unsupported trench wall.

(t) See Long-Term Excavations

RECOMMENDATIONS/SUGGESTIONS

COMMENTARY

the judgment required for the determination of the stability of excavations and the design of appropriate shoring or shielding.

the contractor to choose a qualified individual, since the contractor would be liable in case of an accident. Even though it is evident that it would be desirable that the qualified person be a registered engineer, not every registered engineer is necessarily qualified, and some qualified individuals may not be registered engineers.

(q) NO CHANGE RECOMMENDED

(r) NO CHANGE RECOMMENDED

(s) NO CHANGE RECOMMENDED

(t) Short-Term Excavations are excavations which are open for 72 hours or less.

(t) See Long-Term Excavations

(u) NO CHANGE RECOMMENDED

(v) NO CHANGE RECOMMENDED

(w) NO CHANGE RECOMMENDED

(x) Delete continuous

(x) Spalling does not have to be continuous to constitute a significant safety hazard.

TEXT SUBMITTED TO WORKSHOP

COMMENTS

- | | |
|--|--|
| (y) <u>Standard Practice</u> is the trenching and shoring practice in Section 1926.652(b). | |
| (z) <u>Struts</u> are the primary support members of a shoring system including but not limited to cross braces, raker braces, jacks, or backties (see figure 6). | (z) It was noted that raker braces and backties should be shown in figure 6. |
| (aa) <u>Stable Slope</u> is the slope which will remain stable for the duration of the excavation. | (aa) |
| (bb) <u>Structural Ramp</u> is a ramp built of material other than soil or rock. | (bb) |
| (cc) <u>Supported Wall</u> is that part of the excavation wall which is supported by a shoring system or shielded by trench boxes or trench shields. | (cc) |
| (dd) <u>Trench Box</u> see trench shield. | (dd) |
| (ee) <u>Trench Shield</u> is a protective device which shields workers in a trench from the effect of mass movement of soil or rock and which can be moved along as work progresses. | (ee) |
| (ff) <u>Wales (walers)</u> are members of the shoring system which are directly supported by struts and which in turn provide support to the sheeting (see figure 4). | (ff) |
| (gg) <u>Working loads</u> are loads which should reasonably be anticipated to occur and which must be resisted with appropriate safety margins, determined in accordance with accepted engineering practice. | (gg) |

RECOMMENDATIONS/SUGGESTIONS

COMMENTARY

(y) NO CHANGE RECOMMENDED

(z) NO CHANGE RECOMMENDED

(aa) NO CHANGE RECOMMENDED

(bb) NO CHANGE RECOMMENDED

(cc) NO CHANGE RECOMMENDED

(dd) NO CHANGE RECOMMENDED

(ee) NO CHANGE RECOMMENDED

(ff) NO CHANGE RECOMMENDED

(gg) NO CHANGE RECOMMENDED

ADDITIONAL DEFINITIONS

Employer is the person or organization who is constructing the excavation.
(i.e., contractor, public utility, etc.)

Mass Movement of Soil or Rock is the displacement of soil or rock caused by overall or local stability failures which could cause death or injury to workers.

ANALYSIS OF WORKSHOP COMMENTS WHICH DO NOT DIRECTLY

1. STANDARD PRACTICE

Three significant statements were made with regard to Standard Practice.

- (a) In the joint memo of the organizers of the Wisconsin workshop, it is stated that, "Any OSHA standard should cover as many situations as possible with Standard Practices."

It was also proposed that Subpart P, rather than the guideline, contain tables and figures (isometric drawings) from which workers can select shoring systems. (Letter from Bradberry; comments in Calif. workshop)

- (b) AFL-CIO, in essence, suggested to have a Standard Practice which is even more standardized than that proposed--namely, have to a depth of 15 ft., a very conservatively designed standard shoring system which would be suitable for all (or most) conditions.

2. STRENGTH OF SHORING SYSTEMS

Two comments were made by the trench box manufacturers with respect to strength requirements, which relate to 1926.652(b)(4)(ii), as well as to the guidelines:

- (a) A triangular, rather than a square pressure diagram should be stipulated for trench boxes.

Shielding is the surrounding of workers in an excavation by a protective structure which isolates them from the effects of mass movement of soil or rock.

RELATE TO SECTIONS IN THE WORKING DRAFT

- (a) It is recommended to include tables and isometric drawings for systems which are deemed to comply with Subpart P in a companion document.

- (a) Tables and isometric drawings are considered an excellent way to convey the Standard Practice. However, because of the diversity of ways in which a contractor can comply with the Standard Practice, a choice of systems not covered in this supplement should also be permitted, as long as an engineer/qualified person determines that the systems comply.

The difficulty with standard tables is particularly evident in the case of timber shoring, where the choice of member sizes frequently depends on local conditions. The supplement will probably have to be updated from time to time to cover recent technological developments.

- (b) The AFL-CIO recommendation merits further study. It would result in a much more conservative system and some problems may arise for contractors or manufacturers who wish to introduce new technology, or even with existing systems presently on the market.

- (a) No change in the Standard Practice is recommended. There is no objection to include a triangular pressure diagram in the guidelines, together with appropriate criteria for restraint conditions of the retaining structure. (It should be noted that the pressure diagrams shown in the guidelines are only "information." Some of the references listed in A.5.2., such as the Navy manual and

- (a) The Standard Practice is intended to be a simplified approach which applies to a wide range of conditions. It is conceivable that under many circumstances, the stipulated pressures would be excessive for trench boxes. However, there are other cases, such as instances where trench boxes are forced into a slightly narrower trench to prevent excessive settlement in the vicinity,

TEXT SUBMITTED TO WORKSHOP

COMMENTS

- (b) The 33 percent overstress for short-term excavations should not be permitted.

3. SOIL CLASSIFICATION

Two alternatives to the proposed soil classification (table 1) were suggested. In the San Francisco workshop (F. Yokel memo), it was suggested to adopt the proposed California classification. In the Boston workshop (Kodak letter), it was suggested to adopt the Matrix classification originally proposed by NBS (refer to BSS 121, "Soil Classification for Construction Practice in Shallow Trenching," Yokel, Felix Y., Tucker, Richard L., and Reese, Lymon C.)

RECOMMENDATIONS/SUGGESTIONS

Tshebotarioff, recommend triangular diagrams.)

COMMENTARY

where the stipulated lateral pressures apply. (One such instance is documented in a recent court case.) It would be unwise to base the design of prefabricated trench boxes on the premise that their use will be restricted to cases where the trench wall is not restrained. On the other hand, the guidelines are for engineers and, in many specific instances, engineering judgment may lead to the conclusion that a triangular pressure diagram is a reasonable assumption.

It should be noted that not all trench box manufacturers wish to design their product for a triangular pressure diagram.

- (b) The 33 percent working stress reduction for short-term excavations results in struts which are compatible with those used in traditional shoring practice. Elimination of this working stress reduction would require upgrading of many systems presently used. The track record of these systems does not seem to justify such a step. It appears that in many instances shoring manufacturers will prefer not to take advantage of this strength reduction so that their systems can be used in both short-term and long-term excavations.

It is recommended to keep the proposed soil classification.

There is little doubt that the Matrix classification has many advantages. The reason it was not chosen is that it has too many choices, and therefore, cannot be readily used from memory (one would have to have some chart or plaque). It also was concluded that four choices of shoring would not be an advantage in the field. At present, there are three choices, and the transition from one to the next (which is likely to occur in many field situations) can be made by simply inserting intermediate struts.

The California classification system has been considered and not recommended because the soil categories cannot be

ANALYSIS OF WORKSHOP COMMENTS WHICH DO NOT DIRECTLY

TEXT SUBMITTED TO WORKSHOP

COMMENTS

4. EXEMPTION OF CERTAIN INDUSTRY GROUPS
FROM COMPLIANCE WITH SUBPART P

The American Gas Association requested in a letter (see Appendix) to be exempt from compliance with Subpart P.

5. PREPARATION OF A VOLUNTARY INDUSTRY
STANDARD

Many workshop participants, representing all the participating groups, noted that a voluntary industry standard should be prepared.

RELATE TO SECTIONS IN THE WORKING DRAFT (Cont'd)

RECOMMENDATIONS/SUGGESTIONS

COMMENTARY

No recommendation

correlated with lateral pressures (for detailed discussions refer to F. Yokel memo on San Francisco workshop).

This problem is considered to be outside the scope of this report.

It is strongly recommended to:

NBS recommended to OSHA to support preparation of such a standard. (NBS could prepare a first draft and subsequent revised drafts, thus insuring rapid progress in the adoption of a voluntary standard.) OSHA so far decline to fund this effort.

1. Prepare a voluntary industry standard.

The standard could be sponsored by ANSI (A10.12).

2. On the basis of the existence of this standard, simplify Subpart P and confine it to concise, unambiguous and easily enforceable regulations.

3. APPENDIX

This appendix contains the original input document that was submitted to the workshop. The document was based on previous NBS studies and on recommendations from NIOSH, AFL-CIO, AGC and the shoring industry.

February 20, 1981

WORKING DRAFT OF SUGGESTED REVISION IN SUBPART P OF
THE SAFETY AND HEALTH REGULATIONS FOR CONSTRUCTION
BASED ON BUILDING SCIENCE SERIES REPORT BSS 127

BY

FELIX Y. YOKEL

FOR WORKSHOP USE ONLY

NOT FOR REFERENCE OR PUBLICATION

U.S. DEPARTMENT OF COMMERCE
NATIONAL BUREAU OF STANDARDS

PREFACE

This is a working draft of a suggested revision of the Occupational Safety and Health Administration, (OSHA), 29 CFR Part 1926. Subpart P, Excavation, Trenching, and Shoring regulations. It was prepared as a text for discussion and comment at regional industry workshops. The purpose of this draft is to convey a better understanding of how the recommendations of a National Bureau of Standards (NBS) study^{1/}, if adopted, could be implemented in excavation practice in general and how they would affect the provisions of Subpart P in particular.

At the conclusion of the regional workshops, summaries of the proceedings, comments, and final recommendations will be prepared in collaboration with the interested industry groups. These summaries will be forwarded to OSHA through the National Institute for Occupational Safety and Health (NIOSH), as recommendations for changes to Subpart P. The summaries will become part of the record on which OSHA, through the formal rulemaking procedure established by law, will base revisions to Subpart P.

Industry, labor, and other concerned groups and individuals will have further opportunity to address issues unresolved at the workshops, as well as other issues concerning these revisions, during the rulemaking process.

This working draft has several parts:

Pages 5-20 contain a suggested revised version of Subpart P.
Pages 21-50 contain suggested guidelines which supplement Subpart P.

Pages 51-59 contain an attachment with a summary of suggested changes in the present version of Subpart P.

The following comments should help explain the intent of this working draft.

1. The "Acceptable Practice" in Section 1926.652(a) explains when the provisions apply and how they are to be used.
2. The "Standard Practice" in Section 1926.652(b) is addressed to field personnel with the intent of making the selection of slopes or shoring in the field as simple as possible. It is assumed that the shoring or shields selected will be pre-designed.
3. Section 2 of the guidelines deals with the pre-design or rating of shoring systems, trench shields and trench boxes. It is addressed to contractors, shoring manufacturers and engineers and is as precise and unambiguous as possible.

^{1/} Yokel, F. Y., Recommended Technical Provisions for Construction Practice in Shoring and Sloping of Trenches and Excavations, NBS Building Science Series 127, Washington, D.C., June, 1980.

4. Appendix A of the guidelines contains engineering guidelines and correlates accepted engineering practice with the revised version of Subpart P.
5. Appendix B of the guidelines contains specific information on acceptable shoring systems in the form of tables and charts which would aid field personnel and contractors in the selection of shoring.

This working draft was prepared in consultation with individuals from the various groups involved in excavations, i.e., labor unions, shoring manufacturers, contractors, and engineers. The first draft was prepared with input from the labor unions and shoring manufacturers, and relatively little input from contractors. The draft was subsequently discussed in a two-day meeting of an AGC task committee which was also attended by NBS personnel. In this meeting consensus was reached on various desirable revisions. Where these revisions substantially deviate from the original draft or from the original NBS recommendations they are included herein in parentheses with a question mark. Thus, for instance, "...shielding and sloping requirements must be determined by an engineer (qualified person?)" means that the task committee recommends that a "qualified person" be substituted for "an engineer".

SOME ISSUES THAT SHOULD BE CONSIDERED IN THE WORKSHOPS:

1. Page 6. Section 1926.651(a): This section appears to fall within the scope of Subpart S. Should it be dropped?
2. Page 8. Section 1926.651(p): Should the exit requirements for excavations start at 5 ft, rather than 4 ft depth? (This would remove most excavations less than 4 ft deep from the scope of Subpart P.) Should exit requirements be waved for excavations which are wide enough to permit people to escape toward the center of the excavation? Should it be recognized that large enough pipes or other covered structures can shelter people? Should "negotiable slope" be better defined?
3. Page 9. Section 1926.652(a)(2): Could the depth limitation in the "Standard Practice" be extended to 24 ft? If so, should there be a more stringent limit for Class C soils? Should a "qualified person" be substituted for an "engineer", and if so, is the definition of a "qualified person" good enough so that a determination of who is a "qualified person" is possible? (This issue also applies to other sections of the working draft.)
4. Page 10. Section 1926.652(b)(1): Should the short-term excavation definition extend to 7-days rather than 1-day? If so, do we need more conservative requirements?
5. Page 11. Table 1: Should the stipulation of maximum slope be limited to 3/4:1? Should the suggested performance requirement (footnote b) (the "stable slope" concept) be used? Will this approach work?
6. Page 12. Figure 2: Should the allowable bank next to the work area in Cases II, III and IV be increased to 4 ft? Should "Case IV" be limited to excavation by trenching machines?
7. Page 13. Section 1926.652(b)(4)(ii): This section, unlike most others in Subpart P, is not addressed to the man in the field, but to those who pre-design shoring systems. Yet the section is necessary to avoid unreasonable vagueness. Should this section be at the end of Subpart P? Should part of it be conveyed as definitions?

8. Page 16. Section 1926.652(b)(5)(ii): This section makes it difficult to implement some of the slope configurations allowed in Fig. 2. Should the proposed performance statements be substituted to give more options, or alternately, should more options be specified or the specified options identified as examples of implementing the performance statement?
9. Page 16. Section 1926.652(b)(5)(iii): Should the allowable excavation below the bottom of shoring or shields be increased to 3 ft?
10. Page 18. Definition of "Accepted engineering requirements" Should "a registered architect" be omitted since architects do not deal with excavations?
11. Page 18. Definition of "Competent Person": Should the definition be re-written to require that the competent person be working at the excavation site?
12. Should "Mass Movement of Soil or Rock" be defined?
13. Page 52. Old 1926.651(c): Should this statement be deleted? even though this matter is addressed elsewhere, this statement conveys the intent of Section 1926.652 in simple language.

SUBPART P - EXCAVATIONS AND SHORING

1926.650-GENERAL PROTECTION REQUIREMENTS

- (a) The regulations contain minimum requirements for the protection of workers in, and adjacent to, excavations against death and injury.
- (b) Walkways, runways, and sidewalks shall be kept clear of excavated material or other obstructions and no sidewalks shall be undermined unless shored to carry a minimum live load of one hundred and twenty-five (125) pounds per square foot.
- (c) If planks are used for raised walkways, runways, or sidewalks, they shall be laid parallel to the length of the walk and fastened together against displacement.
- (d) Planks shall be uniform in thickness and all exposed ends shall be provided with beveled cleats to prevent tripping.
- (e) Raised walkways, runways, and sidewalks shall be provided with plank steps on strong stringers. Ramps, used in lieu of steps, shall be provided with cleats to insure a safe walking surface.
- (f) All Employees shall be protected with personal protective equipment for the protection of the head, eyes, respiratory organs, hands, feet, and other parts of the body as set forth in Subpart E of this part.
- (g) Employees exposed to vehicular traffic shall be provided with and shall be instructed to wear warning vests marked with or made of reflectorized or high visibility material.
- (h) Employees subjected to hazardous dusts, gases, fumes, mists, or atmospheres deficient in oxygen, shall be protected with approved respiratory protection as set forth in Subpart D of this part.
- (i) No person shall be permitted under loads handled by power shovels, derricks, or hoists. Employees shall be required to stand away from any vehicle being loaded.

- (j) A competent person shall inspect the excavation for evidence of possible cave-ins or slides, and indications of structural failure in members of the shoring system. If evidence of possible cave-ins or slides or structural failures is apparent, all work in the excavation shall cease until necessary precautions have been taken to safeguard employees.

The competent person shall conduct an overall inspection of the excavation and the ground adjacent to the excavation at least twice daily and shall conduct a special inspection after every rainstorm, penetration of water into the excavation, or other disturbance that could weaken the soil or the shoring system, and shall increase protection against slides and cave-ins if necessary.

Dewatering operations and equipment shall be monitored by a competent person to insure their proper operation and precautions shall be taken to safeguard the workers in the excavation if dewatering equipment malfunctions.

1926.651-SPECIFIC EXCAVATION REQUIREMENTS

- (a) Prior to opening an excavation, efforts shall be made to determine whether underground installations; i.e., sewer, telephone, water, fuel, electric lines, etc., will be encountered, and if so, where such underground installations are located. When the excavation approaches the estimated location of such an installation, the exact location shall be determined and when it is uncovered, proper supports shall be provided for the existing installation. Utility companies shall be contacted and advised of proposed work prior to the start of actual excavation.
- (b) Trees, boulders, and other surface encumbrances, located so as to create a hazard to employees involved in excavation work or in the vicinity thereof at any time during operations, shall be removed or made safe before excavating is begun.
- (c) (1) In excavations which employees may be required to enter, excavated or other material shall be effectively stored and retained at least 2 feet or more from the edge of the excavation.

(2) As an alternative to the clearance prescribed in subparagraph (1) of this paragraph, the employer may use effective barriers or other effective retaining devices in lieu thereof in order to prevent excavated or other materials from falling into the excavation.

- (d) Diversion ditches, dikes or other suitable means shall be used to prevent surface water from entering an excavation and to provide adequate drainage of the area adjacent to the excavation. Water shall not be allowed to accumulate in an excavation, unless this condition is considered in the design and in the initial work plan and adequate provisions are made to protect workers.
- (e) If it is necessary to place or operate power shovels, derricks, trucks, materials, or other heavy objects on a level above and near an excavation, the side of the excavation shall be shored as necessary to resist the extra pressure due to such superimposed loads.
- (f) Blasting and the use of explosives shall be performed in accordance with Subpart U of this part.
- (g) When mobile equipment is utilized or allowed adjacent to excavations, substantial stop logs or barricades shall be installed. If possible, the grade should be away from the excavation.
- (h) Adequate barrier physical protection shall be provided at all remotely located excavations. All wells, pits, shafts, etc., shall be barricaded or covered. Upon completion of exploration and similar operations, temporary wells, pits, shafts, etc., shall be backfilled.
- (i) If possible, dust conditions shall be kept to a minimum by the use of water, salt, calcium chloride, oil, or other means.
- (j) In locations where oxygen deficiency or gaseous conditions are possible, air in the excavation shall be tested. Controls, as set forth in Subparts D and E of this part, shall be established to assure acceptable atmospheric conditions. When flammable gases are present, adequate ventilation shall be provided or sources of ignition shall be eliminated. Attended emergency rescue equipment, such as breathing apparatus, a safety harness and line, basket stretcher, etc., shall be readily available where adverse atmospheric conditions may exist or develop in an excavation.
- (k) Where employees or equipment are required or permitted to cross over excavations, walkways or bridges with standard guardrails shall be provided.

- (l) Where structural ramps are used for employees or equipment, they shall be designed and constructed by qualified persons in accordance with accepted engineering requirements.
- (m) All ladders used on excavation operations shall be in accordance with the requirements of Subpart L of this part.
- (n) Materials used for shoring, sheeting, and underpinning of structures adjacent to excavations shall not be damaged or weakened by corrosion, deterioration or prior use to an extent that will cause them to have a minimum strength less than that required in Section 1926.652(b)(4)(ii).
- (o) Employees entering bell-bottom pier holes shall be protected by the installation of a removable-type casing of sufficient strength to resist shifting of the surrounding earth. Such temporary protection shall be provided for the full depth of that part of each pier hole which is above the bell. A lifeline, suitable for instant rescue and securely fastened to a shoulder harness, shall be worn by each employee entering the shafts. This lifeline shall be individually manned and separate from any line used to remove materials excavated from the bell footing.
- (p) When employees are required to be in trenches 4 (5?) feet deep or more, an adequate means of exit, such as a ladder, steps or a negotiable slope shall be provided and located so as to require no more than 25 feet of lateral travel.
- (q) Shoring shall follow the excavation as closely as practical in order to avoid long sections of unshored excavation.
- (r) Members of the shoring system shall be installed in their proper position and secured to prevent failure.
- (s) Portable trench boxes or sliding trench shields may be used for the protection of personnel in lieu of a shoring system or sloping. Where such trench boxes or shields are used they shall be designed, constructed, and maintained in a manner which will provide protection equivalent to that provided by the shoring required for the excavation.
- (t) Backfilling and removal of trench support shall progress together from the bottom of the trench. Struts shall be released slowly and, in unstable soils, ropes shall be used to pull out the jacks or braces from above after employees have cleared the trench.

1926.652-SPECIFIC SHORING, SHIELDING AND SLOPING REQUIREMENTS

(a) Acceptable Practice

(1) The following excavations are exempt from shoring, shielding and sloping requirements:

- a. Excavations less than 5 ft. deep, except when examination of the ground by a competent person indicates that hazardous ground movement may occur.
- b. Excavations in unfractured rock.

(2) Excavations from 5 ft. to 20 ft. (24 ft. ?) deep shall be shored, shielded or sloped in accordance with the Standard Practice in Section 1926.652(b) with the following exceptions;

- a. If there is a deviation from the provisions of the Standard Practice, shoring, shielding or sloping requirements must be determined by an engineer (a qualified person ?).
- b. An engineer shall determine the shoring, shielding or sloping requirements whenever the bottom of a building foundation adjacent to the excavation which has not been secured by underpinning extends into the critical zone delineated in Figure 1.

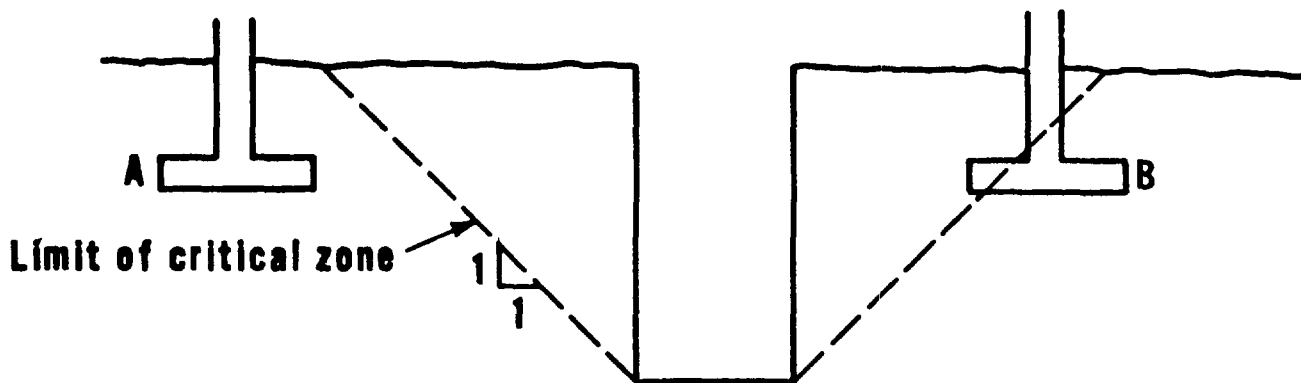

FOOTING A: Standard practice can be followed

FOOTING B: An engineer shall be consulted

Figure 1. Effects of Nearby Foundation Loads That Must be Determined by an Engineer

- (3) For all excavations deeper than 20 (24?) ft., except those in unfractured rock, an engineer (qualified person?) shall determine the shoring, shielding or sloping requirements.

- (b) Standard Practice

- (1) Scope

The Standard Practice provides a method by which field conditions are related to shoring, shielding and sloping requirement.

The Standard Practice makes a distinction between short-term and long-term excavations (see definition in 1926.653 - 24 hours (7 days?) is the division point).

- (2) Soil Classification

Soils are divided into three types: A, B, and C. For each soil type the "equivalent weight effect", w_e , to be used for the calculation of lateral soil pressure on shoring systems, and the maximum permissible sideslope for sloped excavations are stipulated. Table 1 provides guidance for the selection of the soil type.

- (3) Sloped Excavations

Sloped excavations shall not have sideslopes steeper than those stipulated in Table 1. If there is any indication of general or local instability, slopes shall be cut back to the stable slope. The slope configurations shown in Figure 2 can be used.

- (4) Shored and Shielded Excavations

- (i) Determination of Adjusted Depth

For the purpose of selecting shoring systems, trench shields, or trench boxes the depth of excavations shall be assumed greater than the actual depth in order to allow for spoil piles, construction equipment and sloping ground. This adjusted depth (H_e) shall be determined as follows:

- a. For ground sloping down from the supported or shielded excavation wall, level ground, or ground sloping up from the supported or shielded excavation wall with a slope less than 3 hor. in 1 vert. the Adjusted Depth (H_e) is the actual depth of the supported excavation (H) plus 2 ft. (surcharge allowance). (See Figure 3(a).)

Table 1. Soil Classification System for the Standard Practice

Soil Type	Description	w_e lb/ft ³	Steepest Allowable Slope hor.:vert. ^{b/}	
			Depth 12 ft. or less	Depth Greater than 12 ft.
A	Intact Hard	20 ^{a/}	3/4:1	1:1
B	Medium	40	3/4:1 ^{c/}	1 1/2:1
C	Saturated, Submerged or Soft	80	1 1/2:1	2:1

Notes:

1. Type A: Intact Hard Soils include stiff clays and clayey (cohesive) sands and gravels^{d/} (hardpan, till) above the ground water table which have no fissures, weak layers, or inclined layers that dip toward the bank of the excavation as stipulated in Note 3. Stiff clays included have an unconfined compressive strength^{e/} $q_u = 1.5$ tsf or more. Intact hard soils subject to vibrations by heavy traffic, pile driving or similar effects are Type B.
2. Type B: Medium Soils are all soils which are not Type A or C.
3. Type C:
 - a. Soft Soils include cohesive soils^{d/} with an unconfined compressive strength^{e/} of 0.5 tsf or less and soils that cannot stand on a slope of 3 hor.: 1 vert. without slumping (muck).
 - b. Saturated or Submerged Soils are assumed whenever water seeps into the excavation from the soil forming the bank; or water is retained by tight sheeting; or there is a possibility that the excavation may be entered by workers within 1 day after more than half of its depth was flooded and pumped out.
4. Layered Systems (two or more distinctly different soil or rock types or micaceous seams in rock) which dip toward the bank of the excavation with a slope of 4 hor.: 1 vert. or steeper are considered Type C. Layered soils are classified in accordance with the weakest layer.
5. Rock: Fractured rock shall be considered Type B when it is dry and Type C when it is submerged. Unfractured rock is exempt from shoring and sloping requirements.

-
- ^{a/} In long-term excavations "Intact Hard" soil is Type B soil.
- ^{b/} If there is any indication of general or local instability slopes shall be cut back to a slope which is at least 1/4 hor.:1 vert. flatter than the specified slope.
- ^{c/} In long-term excavations steepest allowable slope shall be 1:1.
- ^{d/} Cohesive soils are clays (fine grained) or soils with a high clay content which have cohesive strength. They do not crumble, can be excavated with vertical side-slopes, are plastic (can be molded into various shapes and rolled into threads) when moist and are hard to break up when dry.
- ^{e/} Unconfined compressive strength can be determined by undrained laboratory tests, field tests, or the following thumb penetration tests: stiff clays with an unconfined compressive strength of 1.5 tsf can be readily indented by the thumb nail. They can be indented by the thumb, but can be penetrated by the thumb only with very great difficulty. Cohesive soils with an unconfined compressive strength of less than 0.5 tsf can be easily penetrated several inches by the thumb and can be molded by light finger pressure. tsf=tons per square foot.
- (^{b/} ...Slopes shall be cut back to the stable (flatter) slope? Change Table 1 to use 3/4:1 maximum slope as the only limitation?)

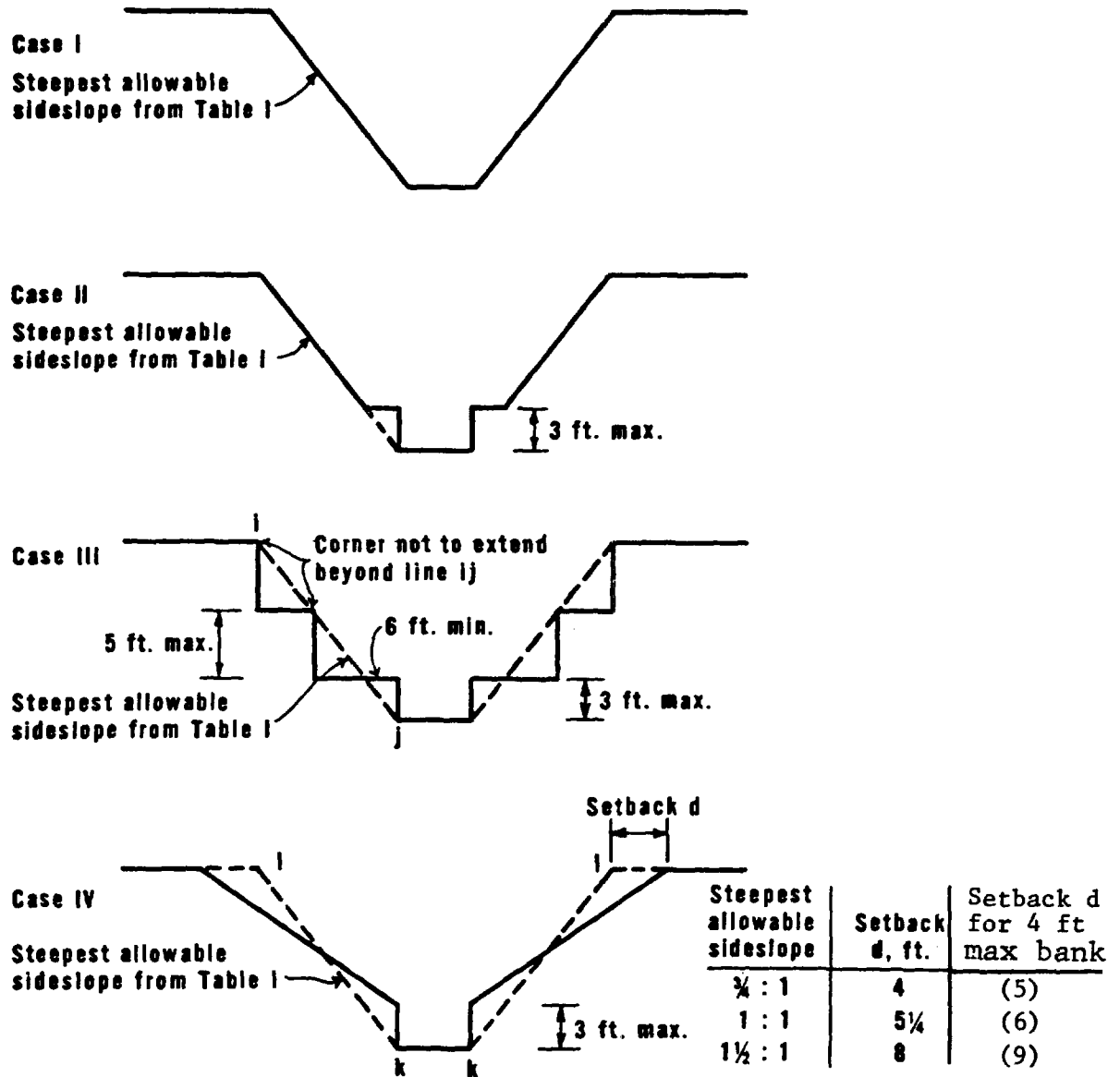

Case I - Simple slope

Case II - Compound slope with bench no more than 3 ft. high

Case III & IV - Configuration must meet following criteria:

1. No vertical bank to exceed 5 ft., the vertical bank adjacent to the work area not to exceed 3 ft. (4 ft. ?)
2. Imaginary slopes ij and ki not to exceed steepest allowable sideslope from Table I

Figure 2: Allowable Configurations of Sloped Excavations
(Cases II, III and IV are for short-term excavations)

- b. For ground sloping up from the supported or shielded excavation wall with a slope of 3 hor.:1 vert. or steeper the adjusted Depth (H_e) is determined in accordance with Table 2 and Figure 3(b).
- c. For heavy equipment (20,000 lb. or more) near the side of the supported or shielded excavation wall the additional depth shown in Table 3 shall be added to the 2-ft. surcharge allowance stipulated in a. No additional depth needs to be added for equipment operating at a distance from the side of the excavation wall which is equal to, or larger than, the depth of the supported or shielded excavation (H).

(ii) Required strength of Shoring Systems, Trench Shields and Trench Boxes.

Shoring systems, trench shields and trench boxes shall have adequate strength to resist the following working loads:

- a. A uniformly distributed lateral pressure equal to the equivalent weight effect (w_e) in Table 1 times the Adjusted Depth (H_e) of the Excavation.
- b. A 240 lb gravity load distributed over a 1 ft length at the center of any strut (cross brace).
- c. A 240 ft-lb impact load acting toward the excavation on the walls of trench shields and trench boxes.

Loads a. and b. shall be assumed to act simultaneously. Only trench shields and trench boxes need to resist load c.

Shoring systems shall be designed in accordance with accepted engineering practices. A 33 percent increase in allowable working stresses or an equivalent strength reduction shall be acceptable for shoring systems, trench shields or trench boxes used in short-term excavations.

(iii) Selection of Shoring System, Trench Shields, and Trench Boxes

Shoring systems, trench shields and trench boxes shall be selected in the field on the basis of Soil Type (Table 1), Adjusted Depth (Section 1926.652(b)(4)(i)) and a determination whether the excavation is long-term or short-term in the following manner:

- a. Trench shields, trench boxes, pre-fabricated strut-wale assemblies and other pre-fabricated assemblies shall be rated for the maximum Adjusted Depths in Type A, B, and C soils in which they can be used, and selected accordingly.

Table 2. Determination of Adjusted Depth for Ground Sloping Toward the Supported or Shielded Excavation Walls (includes vertical cuts at the bottom of sloped trenches-see Figure 3(b))

Slope of Ground	Adjusted Depth for Long Slope ^{a/}
3 hor.:1 vert.	1.67 times the depth of the supported excavation (H)
2 hor.:1 vert.	2 times the depth H
1 hor.:1 vert.	3 times the depth H
3/4 hor.:1 vert.	3.7 times the depth H

^{a/} If the supported excavation wall is at the bottom of a sloped excavation (see Figure 3(b)) the equivalent depth needs not to exceed the total depth of the excavation (H in Figure 3(b)) plus a 2 ft. surcharge allowance.

Table 3. Additional Surcharge Allowance in ft. for Heavy Equipment Near the Supported or Shielded Excavation Wall (to be added to the standard 2 ft. allowance) (See Figure 3(c))

Weight of Equipment, W	Depth of Trench and Soil Type								
	10 ft.			15 ft.			20 ft.		
	A	B	C	A	B	C	A	B	C
20,000 lb	2	--	--	1	--	--	1	--	--
50,000 lb	7	2	--	5	2	--	4	1	--
100,000 lb	10	4	1	8	3	--	6	2	--

- Notes:
- Distance between the tracks of the equipment (edge of wheel or chain) and the supported excavation wall not to be less than 4 ft.
 - Distance between the center of the equipment load and the supported excavation wall not to be less than 6 ft.
 - If the spoil pile and the heavy equipment are on the same side of the supported excavation wall, the average depth of the spoil pile shall be added to the surcharge allowance in Table 3.
 - If the equipment load is distributed over a length parallel to the trench which is shorter than the following lengths: 10 ft. for 20,000 lb equipment; 12 ft. for 50,000 lb equipment; 20 ft. for 100,000 lb equipment follow the Guidelines Supplementing Subpart P or accepted engineering practice.
Example: a 50,000-lb 12-ft long crane operates on the side of a 15-ft. trench in Type B soil. Adjusted depth: 15 ft. + 2 ft. + 2 ft. (Table 3)=19 ft.

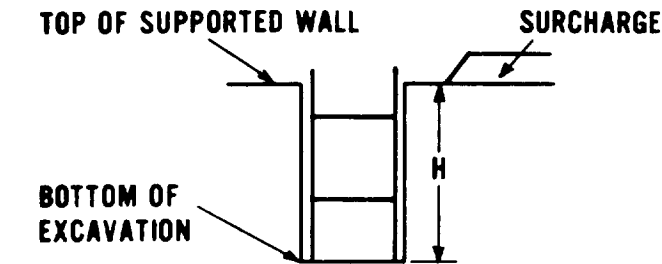

(a) AVERAGE CONDITION, TERRAIN NOT
STEEPER THAN 3 hor : 1 vert
ADJUSTED DEPTH = $H+2ft$

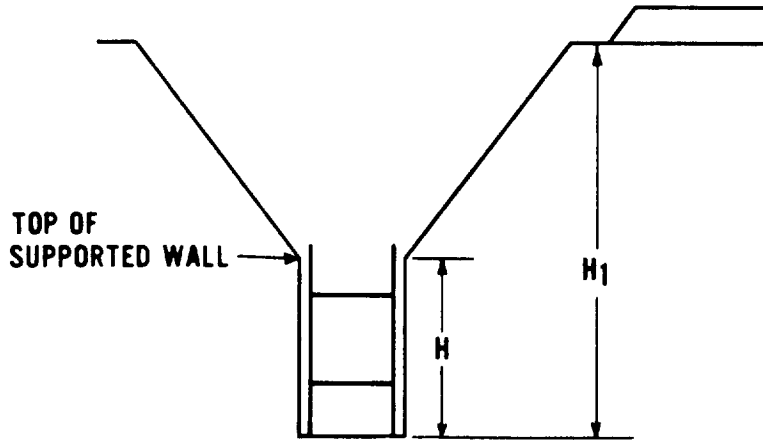

(b) GROUND SLOPING UP FROM
SUPPORTED WALL
ADJUSTED DEPTH IN ACCORDANCE
WITH TABLE 2, BUT NOT MORE
THAN H_1+2ft

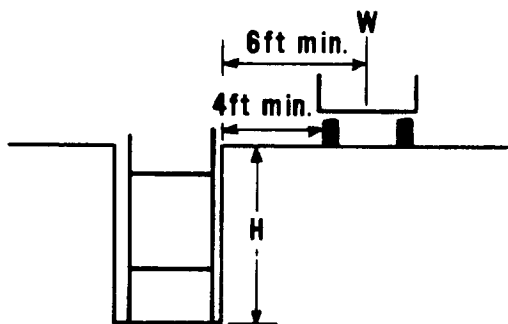

(c) HEAVY EQUIPMENT LOADS
ADJUSTED DEPTH: ADD THE
DEPTH FROM TABLE 3 TO THE
2ft SURCHARGE ALLOWANCE
ADJUSTED DEPTH = $H+2ft+H_w$
 H_w IS FROM TABLE 3

H = DEPTH OF SUPPORTED EXCAVATION

Figure 3: Determination of Adjusted Depth

- b. Hydraulic shores or other pre-fabricated sub-assemblies or members of shoring systems shall be rated for allowable working loads and selected with the aid of the charts in the guidelines supplementing Subpart P, or selected directly from special charts prepared by the manufacturer.
- c. Timber shoring shall be selected with the aid of charts in the guidelines supplementing Subpart P or from special charts prepared by an engineer (qualified person?).
- d. Any other shoring system can be pre-designed and rated by an engineer (qualified person?) and selected on the basis of soil type and equivalent depth from charts prepared for this purpose.

(5) Special Provisions

(i) Intersecting Trenches

When two trenches intersect and one trench is shored, the intersecting trench shall also be shored from the intersection of the two trench walls to a distance of not less than its depth.

(ii) Sloping Ground

If the ground behind an excavation wall slopes up from the excavation wall and the ground slope exceeds 3 hor. in 1 vert. workers in the excavation must be protected against objects rolling or sliding from the sloped ground. This can be accomplished by projecting the sheeting at least 18 inches above the ground surface or by a specially constructed protective toeboard. If spaced sheeting is used provisions shall be made to close the gaps between projecting sheeting members. (Workers in excavations must be protected against rolling or sliding objects?)

(iii) Excavation Below the Bottom of Sheeting, Trench Shields, or Trench Boxes

Excavation up to 2 ft. (3 ft. ?) below the bottom of sheeting, trench shields or trench boxes is permitted in short-term excavations provided that:

- a. No soil movement below the bottom of the sheeting, trench shield or trench box is evident; and
- b. The forces acting on the bracing, trench shield, or trench box are calculated for the full depth of the excavation, and the lowest wales and struts are designed to resist the forces that would result if the sheeting would be projecting to the bottom of the excavation.

(iv) Maximum Spacing of Spaced Sheeting^{a/}

Maximum allowable spacing of spaced sheeting shall be in accordance with Table 4 (a) or (b) which ever controls.

Table 4(a) Maximum Center-to-Center Spacing^{b/} of Spaced Sheeting Members

Soil Type	Depth of Excavation		
	5 ft. - 10 ft.	10 ft. - 15 ft.	15 ft. - 20 ft.
A	8 ft.	6 ft.	4 ft.
B	4 ft.	4 ft.	3 ft.
C	Tight Sheeting Required.		

Table 4(b) Maximum Clear Spacing^{b/} of Spaced Sheeting Members

Soil Type	Depth of Excavation		
	5 ft. - 10 ft.	10 ft. - 15 ft.	15 ft. - 20 ft.
A	7.5 ft.	5.5 ft.	2 ft.
B	3 ft.	2 ft.	1 ft.
C	Tight Sheeting Required.		

^{a/} If there is an indication of spalling the spacing must be reduced to a spacing that will prevent spalling.

^{b/} Refer to Figure 4, page 18.

1926.653 DEFINITIONS APPLICABLE TO THIS SUBPART

- (a) "Accepted engineering requirements (or practices)"
Those requirements or practices which are compatible with standards required by a registered architect, a registered professional engineer, or other duly licensed or recognized authority. Guidance for accepted engineering practices pertaining to excavation safety is provided in the guidelines supplementing Subpart P.
- (b) Acceptable Practice is a practice which meets the minimum requirements in Section 1926.652(a).
- (c) Adjusted Depth is the actual depth from the bottom of the excavation to the top of the supported excavation wall plus an additional depth to allow for surcharge, sloping ground, or heavy equipment as stipulated in Section 1926.652(b)(4)(i).
- (d) Allowable Working Stresses are allowable stresses determined in accordance with accepted engineering practices.
- (e) Belled Excavation is a part of a shaft or footing excavation, usually near the bottom and bell-shaped; i.e., an enlargement of the cross section above.
- (f) Clear Spacing of sheeting members is the distance between the edges of sheeting members over which the soil is unsupported (see Figure 4).
- (g) Competent Person means one who is capable of identifying existing and predictable hazards in the surroundings or working conditions which are unsanitary, hazardous, or dangerous to employees, and who has authorization to take prompt corrective measures to eliminate them.
- (h) Engineer is a registered professional engineer.
- (i) Equivalent Weight Effects (w_e) is the weight effect stipulated in Table 1 which is used to calculate pressures on shoring systems.
- (j) Excavation is any manmade cavity or depression in the earth's surface except as noted, including its sides, walls, or faces, formed by earth removal and producing unsupported earth conditions by reasons of excavation. Excavations do not include tunnels and shafts, caissons and cofferdams covered by Subpart S of the Safety and Health Regulations for Construction.
- (k) Excavation Wall is the side of an excavation, rising from the bottom of the excavation to the ground surface.

- (l) Fractured Rock is rock which could spall or crumble when excavated with vertical slopes. Fractured rock slopes secured against mass movement and spalling by rock bolts, netting, or other means approved by a qualified person are considered stable (equal to unfractured rock).
- (m) Long-Term Excavations are excavations which are open for more than 24 hours (7 days?)
- (n) Mud Sills are wales which are installed at the level of the bottom of the excavation wall.
- (o) Negotiable Slope is a slope on which a person can egress from or ingress to an excavation.
- (p) Qualified Person means one who, by possession of a recognized degree, certificate, or professional standing, or who by extensive knowledge, training, and experience, has successfully demonstrated his ability to solve or resolve problems relating to the subject matter, the work, or the project.
- (q) Safety Margin is any measure of excess strength over that required to resist the working loads.
- (r) Sheeting is composed of members of the shoring system which are in direct contact with the soil in the supported bank.
- (s) Shoring Systems are structural systems supporting the bank of an excavation.
- (t) Short-Term Excavations are excavations which are open for 24 hours (7 days?) or less.
- (u) Sides, Walls, or Faces are the vertical or inclined earth surfaces formed as a result of excavation work.
- (v) Slope is an incline expressed as a ratio of horizontal distance to vertical rise.
- (w) Spaced Sheeting is sheeting in which the members bearing against the excavation wall are spaced (see Figure 6).
- (x) Spalling is the continuous flaking and falling of soil or rock from an unsupported trench wall.
- (y) Standard Practice is the trenching and shoring practice in Section 1926.652(b).
- (z) Struts are the primary support members of a shoring system including but not limited to cross braces, raker braces, jacks and backties (see Figure 6).
- (aa) Stable Slope is the slope which will remain stable for the duration of the excavation.

- (bb) Structural Ramp is a ramp built of material other than soil or rock.
- (cc) Supported Wall is that part of an excavation wall which is supported by a shoring system or shielded by trench boxes or trench shields.
- (dd) Trench Box see trench shield.
- (ee) Trench Shield is a protective device which shields workers in a trench from the effect of mass movement of soil or rock and which can be moved along as work progresses.
- (ff) Wales (walers) are members of the shoring system which are directly supported by struts and which in turn provide support to the sheeting (see Figure 4).
- (gg) Working Loads are loads which should reasonably be anticipated to occur and which must be resisted with appropriate safety margins, determined in accordance with accepted engineering practice.

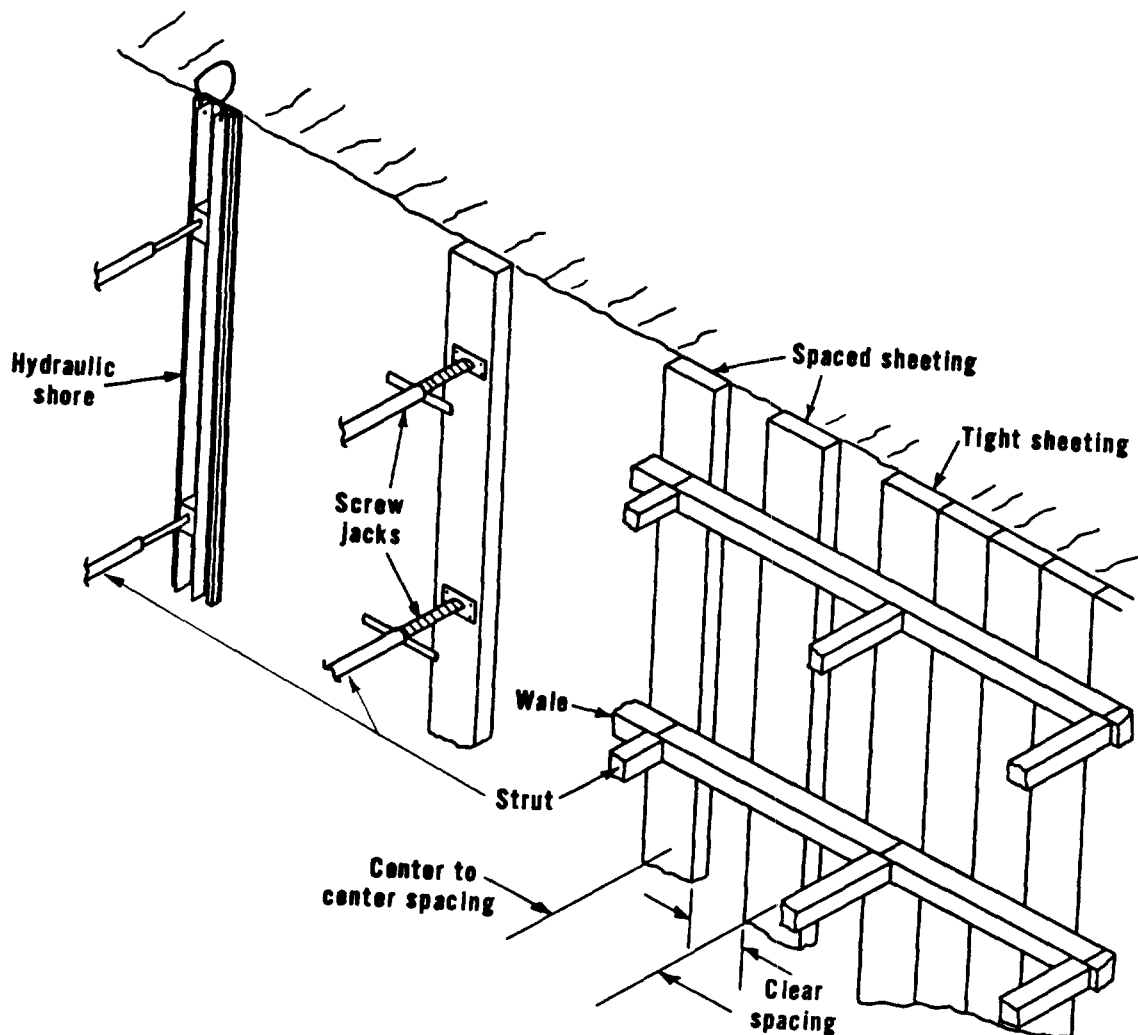

Figure 4. Components of the Shoring System

GUIDELINES SUPPLEMENTING SUBPART P OF THE SAFETY AND HEALTH REGULATIONS FOR CONSTRUCTION

1. DEFINITIONS

- (a) Average Strength is the average failure load obtained in tests of not less than 5 randomly selected samples corrected for effects of load duration.
- (b) Design Criteria are design rules which, if followed, will reduce the risk of occurrence of design limit states to acceptable levels.
- (c) Design Limit States are failure modes which endanger workers in, or adjacent to, excavations.
- (d) Design Loads are loads used for the design of shoring systems or the determination of slope stability. Design loads may be working loads or factored loads.
- (e) Factored Loads are working loads multiplied by the factors stipulated in Section 2.1.B of the Guidelines.
- (f) Failure Loads are loads which will cause failure of a member of the shoring system that can endanger workers in the trench or render the member unserviceable.
- (g) Load Capacity is a measure of strength defined in Section 2.1B.
- (h) Safety Factor is the ratio of load capacity to the effect of the most critical combination of working loads. In the case of excavation stability, the safety factor is the ratio of resisting forces to driving forces. For excavation slope stability the safety factor can be taken as the ratio of critical height to actual height.
- (i) Safety Margin is any measure of excess strength over that required to resist the working loads.
- (j) Short-Term Strength Properties of Soils are the strength properties of the soil adjacent to the excavation during the period of exposure. Some of this strength can be lost with the passage of time by such effects as desiccation and lateral expansion. A typical short-term strength property is apparent cohesion in moist sands. In some instance there may be an increase in strength with time (for instance drained vs. undrained strength).

2. STRENGTH REQUIREMENTS FOR PRE-DESIGNED SHORING SYSTEMS, TRENCH BOXES AND TRENCH SHIELDS TO BE USED IN THE STANDARD PRACTICE

2.1 Design of Shoring Systems

Shoring systems, trench shields, and trench boxes shall be designed to resist the working loads stipulated in Section 2.2. The term "designed to resist" is interpreted as follows [A or B].

- A. The following stresses are not exceeded: 1.33 times the allowable working stresses in short-term excavations; 1 times the allowable working stresses in long-term excavations. "Allowable Working Stresses" are the "allowable stresses" stipulated in applicable standards in conjunction with traditional "working stress" design (using unfactored loads). For timber shoring which is left in place (not re-used for other excavations) allowable working stresses can be adjusted for load duration as follows: 1 - week duration for short-term excavations; 1 - year duration for long-term excavations. Allowable stresses for hardwood timber shall comply with Table 1.
- B. The system has adequate load capacity to resist the following factored loads: 1.3 times the working loads stipulated in Section 2.2 in short-term excavations. 1.7 times the working loads stipulated in Section 2.2 in long-term excavations.

"Load capacity" is defined as one of the following:

- a: "Design strength" as defined for reinforced concrete members in ACI 318 (see Section 2.5 or
- b: "maximum strength" as defined for steel members in Part 2 of the AISC Specifications (see Section 2.5) or
- c: $S = \bar{S} (1 - 1.65v)$ for members which cannot be designed by the standards listed in Section 2.5, where:

S = load capacity

\bar{S} = average strength (failure load corrected for load duration if applicable)

v = coefficient of variation of strength.

2.2 Loads Acting on Shoring Systems, Trench Shields and Trench Boxes

2.2.1 General

All loads given in this section are "working loads". They are loads which shall reasonably be anticipated and which must be resisted with the safety margins stipulated herein and in the standards listed in Section 2.5.

2.2.2 Operational Loads

The following minimum load shall be used for the design of all struts (cross braces): A gravity load of 240 lb. distributed over a 1 ft. long portion in the center of the span of the strut or at the location where its effect is most critical.

In addition to the 240 lb. gravity load and the lateral loads in 2.2.3, trench shields, trench boxes and shoring systems installed by methods which do not assure that the sheeting bears tightly against the excavation wall (there may be an open space between the bank and the sheeting) shall withstand without failure an impact energy of 240 ft.-lb. applied at any point against the sheeting side facing the excavation wall (toward the excavation). Only in shoring systems whose struts are pre-loaded, the sheeting shall be assumed to bear tightly against the excavation wall.

2.2.3 Lateral Soil Pressures

Lateral soil pressure per unit surface area of the supported excavation wall shall be calculated by the following equation:

$$p = w_e H_e$$

where:

p = a uniformly distributed lateral soil pressure in lb/ft²

w_e = equivalent weight effect from Table 1 in Subpart P, 1926.652 (lb/ft³)

H_e = adjusted depth determined in accordance with Figure 1.
Section 1926.652(b)(4) provides a procedure for the determination of H_e by personnel in the field.

2.2.4 Loads Tributary to Members of the Shoring System

(1) The following portion of the lateral loads caused by the uniform lateral soil pressure p shall be assumed to act on members of the shoring system: 100 percent of the tributary load shall be assumed to act on all struts, 80 percent of the tributary load shall be assumed to act on wales (members directly supported by struts shall be designed as wales), 67 percent of the tributary load shall be assumed to act on sheeting. Tributary load shall be calculated in accordance with Figure 2.

(2) Loads Tributary to Spaced Sheeting

Struts and wales supporting spaced sheeting shall be designed to resist the full tributary lateral load (the same load that would be calculated for tight sheeting).

Spaced sheeting members shall be designed to resist the lateral load tributary to an area equal to the length of the member times the center to center spacing between the sheeting members (this includes the unsheeted portion of the trench wall) as follows:

Sheeting members supported by wales shall be designed to resist 67 percent of the lateral soil pressure " p ". Sheeting members directly supported by struts shall be designed to resist 80 percent of p .

2.3 Rating of Shoring Systems

2.3.1 Components or subassemblies of shoring systems, or fully assembled self-contained shoring systems, shall be rated and subsequently used to resist working loads equal to, or smaller than, those for which they are rated to be adequate.

Rating shall be accomplished as follows:

Struts shall be rated for the compressive working loads they are allowed to resist. If struts are extendable, the rating shall consider length effects on load capacity. Rating of struts shall include consideration of the 240 pound vertical downward load stipulated in Section 2.2.2.

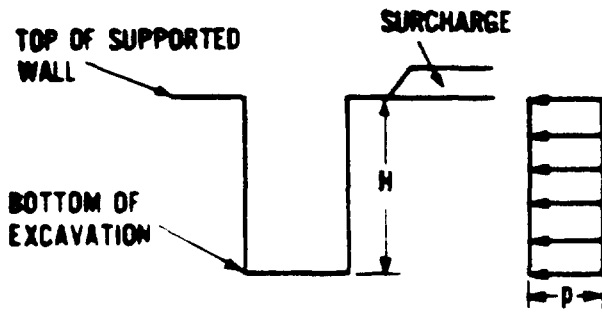

(a) AVERAGE CONDITION TERRAIN NOT STEEPER THAN 3 hor 1 vert

$$H_e = H + 2ft \dots \text{eq (1)}$$

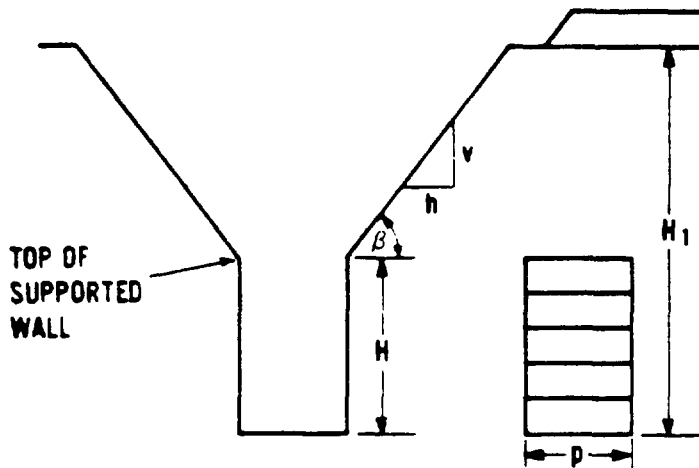

(b) GROUND SLOPING TOWARD SUPPORTED WALL

$$H_e \approx H \left(1 - 2 \frac{v}{h} \right) \approx H (1 - 0.04)$$

$$\text{or } H_e = H_1 + 2ft$$

WHICHEVER IS LESS ... eq 2

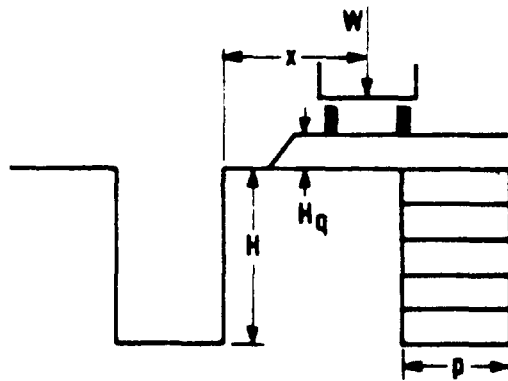

(c) HEAVY EQUIPMENT LOADS

$$H_e = H - H_q - H_w$$

$$H_w = \frac{1}{w_e} \frac{W}{H(\ell \cdot x)} \left(1 - 0.6 \frac{x}{H} \right)$$

$$\approx \frac{1}{w_e} \frac{0.8W}{H(\ell \cdot x)} \quad \text{eq. 3}$$

H_w CAN BE DISREGARDED WHEN $x \geq H$

ℓ = LENGTH OF EQUIPMENT OR LINELOAD IN THE DIRECTION OF THE TRENCH

W = TOTAL FORCE EXERTED BY WEIGHT OF EQUIPMENT OR LINE LOAD

$p = w_e H_e$
 H = DEPTH OF SUPPORTED EXCAVATION
 w_e = EQUIVALENT WEIGHT EFFECT FROM TABLE I

Figure 1. Determination of Adjusted Depth

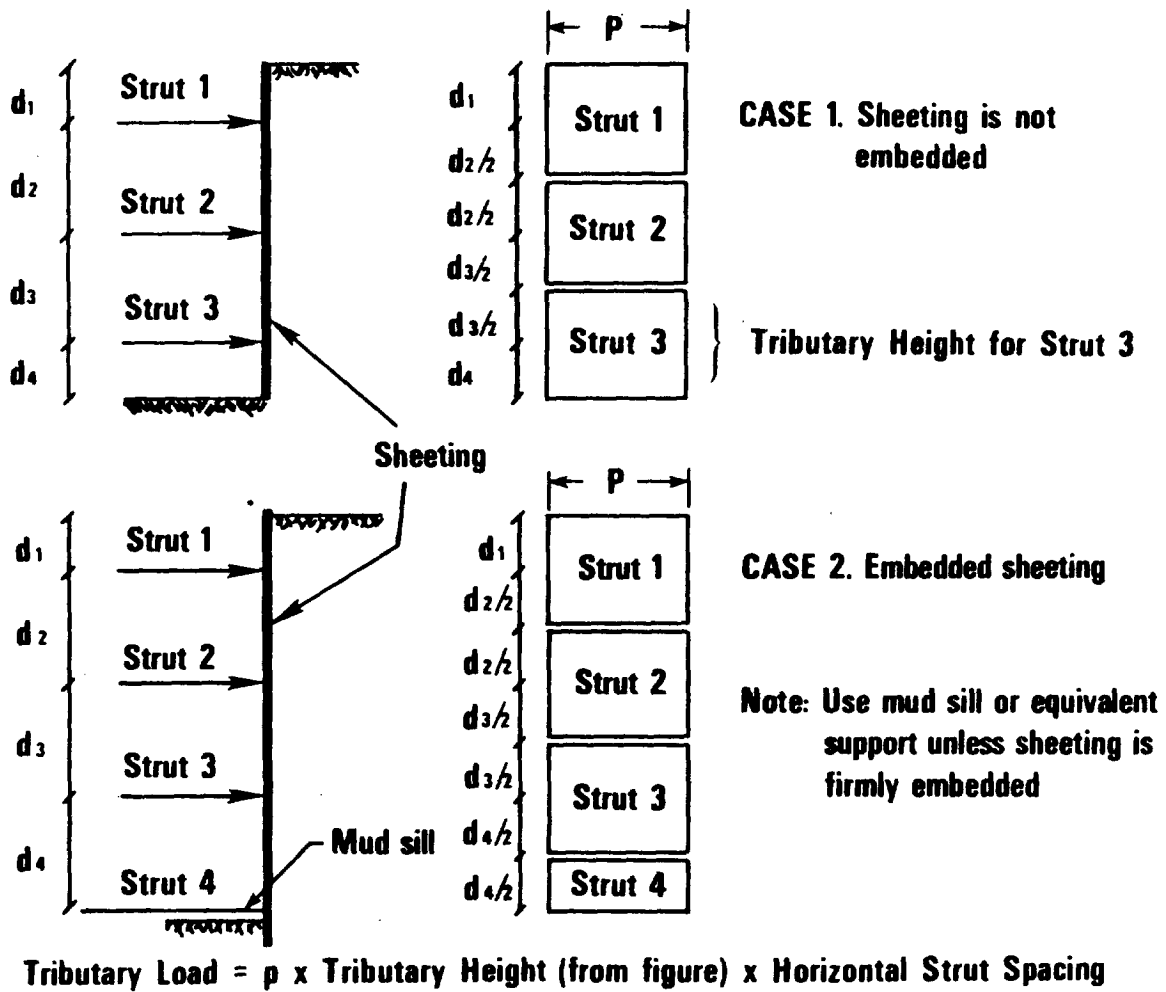

Figure 2. Loads Tributary to Members of the Shoring System

Wales supported at given length intervals shall be rated for allowable load per linear foot of wale. For strut-wale assemblies the wale shall be designed to resist moments and shears not less than 80 percent of those resulting from the tributary allowable strut loads.

Self-contained repetitively-used shoring systems such as trench boxes, hydraulic shoring systems or pre-fabricated strut-wale assemblies can be rated either for allowable working loads (in lb/ft^2 of trench wall), or preferably, for pre-determined conditions of use. Rating for conditions of use shall include designation of maximum allowable adjusted depth for given soil types, (e.g., a trench box could be rated for use in a 20 ft. equivalent depth in Type B soil or, alternately, for an allowable working load of 800 lb/ft^2).

2.3.2 Rating Procedures

The rating shall be based on the professional opinion of an engineer and marked on the component or assembly. It shall be accomplished by engineering analysis or testing. In addition to the loads stipulated in Section 2.2 the engineer shall consider loads resulting from installation and construction procedures.

Repetitively used assemblies or components shall be kept in good repair. This shall be accomplished by renewing the rating at least annually after inspection by a qualified person. Hydraulic shores shall be tested at least once a year to 1.25 times their allowable working load, and the load shall be maintainable for at least 5 minutes without a pressure drop.

2.4 Determination of Load Capacity by Test

If the load capacity of structural components of a shoring system is determined by test, the following minimum requirements shall be used:

- 2.4.1 Strength variability shall be considered in accordance with Section 2.1B.
- 2.4.2 Under no circumstances shall the allowable working load of struts in short-term excavations exceed 67 percent of the average strength, or in long-term excavations 50 percent of the average strength of the component or shoring system.
- 2.4.3 For struts the test load shall be applied with an eccentricity of not less than $1/6$ the thickness of the strut with respect to any one of the principal axes (but not simultaneously with respect to both axes). The test loads shall induce a centerspan moment equal to that caused by a concentrated load of 240 lb times the applicable load factor (Section 2.1B) applied at the center of the strut normal to its axis.* Load eccentricities shall be of the same magnitude and direction on both ends of the strut (single curvature).

2.4.4 Impact load shall be applied by a 60 lb sand filled leather bag fabricated in accordance with Section 12.2 of ASTM E 72-77 [5]. During the impact test the sheeting shall be supported as in actual working conditions. Three successive impact tests shall be applied. "Failure" under impact load is defined as any one of the following: rupture of the sheeting or any of its structural supporting members; any structural damage that would lower the load capacity of the shoring below that required; excessive bending which can endanger workers in the trench.

2.5 Applicable Standards

Structural members of the shoring system shall be designed in accordance with the pertinent provisions in the following standards:

Steel: Specifications for the Design, Fabrication and Erection of Structural Steel for Buildings, American Institute of Steel Construction, New York, N.Y., February 1969.

Concrete: Building Code Requirements for Reinforced Concrete, (ACI 318-77), American Concrete Institute, Detroit, Michigan, November 1977.

Aluminum: Specifications for Aluminum Structures, The Aluminum Association, New York, N.Y., November 1967 [1].

Wood: National Design Specifications for Wood Construction, National Forest Products Association, June 1977, for soft-wood lumber stresses. Because formally approved allowable working stresses do not exist for most hardwood species, applicable ASTM Standards may be followed in conformance with procedures recognized under the American Lumber Standard, PS70/70. Allowable stresses are given in Table 1.

* If the end eccentricity produces the desired center span moment the provision is satisfied.

Table 5. Allowable Unit Stresses in psi for Hardwood Trenching Lumber^{a/}

Hardwood group ^{b/}	2 to 4 in. thick, 2 to 14 in. wide						5 in. and thicker, 5 to 20 in. wide					
	F _b	F _t	F _c	F _v	F _{cl}	E	F _b	F _t	F _c	F _y	F _{cl}	E
White oak ^{c/}	875	575	550	105	355	800,000	975	650	525	120	355	800,000
Mixed oak ^{d/}	850	550	500	80	355	800,000	925	625	475	90	355	800,000
Mixed hardwoods I ^{e/}	725	475	375	65	165	800,000	800	550	350	75	165	800,000
Mixed hardwoods II ^{f/}	600	400	350	50	115	800,000	675	450	325	60	115	800,000

^{a/} Ref. Southern Pine Inspection Bureau Grading Rules, 1977 edition, for general grade description as follows:

Grade	Paragraph	Size
No. 2	313	2 to 4 in. thick, 2 to 4 in. wide
No. 2	343	2 to 4 in. thick, 5 to 14 in. wide
No. 2 SR	406	5 in. and thicker, 5 to 20 in. wide

Assumes 10-yr. load duration basis. For new (first use) lumber, adjustments for load duration may be made: for 1-yr. duration multiply by 1.1; for 1 wk., multiply by 1.25; for 2 days, multiply by 1.30. Load duration adjustments for used trenching lumber are not recommended. For hardwood trenching lumber, requirements are waived for manufacture, compression wood, firm knots, skips, stain and warp. Holes limited as knots; wane limited as given for No. 2 grade in SPIB, 1977 edition.

^{b/} Hardwood species defined per ASTM D 1165.

^{c/} White oak: The following white oaks--bur, chestnut, live, overcup, post, swamp chestnut, swamp white, white.

^{d/} Mixed oak: Red oak (black, cherry bark, laurel, northern red, pin, scarlet, southern red, water, willow); white oak (footnote c).

^{e/} Mixed hardwoods I: Ash (black, blue, green, Oregon); beech; birch (sweet, yellow); cherry; elm (American, rock, slippery); hackberry; hickory (mockernut, pignut, shagbark, shellbark); locust (black, honeylocust); magnolia (cucumber, southern, sweetbay); maple (bigleaf, black, red, silver, sugar); mixed oak (footnote d); pecan (bitternut hickory, nutmeg hickory, pecan, water hickory); red alder; sassafrass; sugarberry; sweetgum; sycamore; tanoak; tupelo (black, water); yellow poplar. Excludes all cottonwood, all aspen, basswood, and balsam poplar.

^{f/} Mixed hardwoods II: All hardwoods in Mixed hardwoods I (footnote e) plus black and eastern cottonwood; quaking and bigtooth aspen; basswood. Excludes balsam poplar.

APPENDIX A. ENGINEERING GUIDELINES FOR THE DESIGN OF SHORING SYSTEMS
AND OTHER MEANS TO PREVENT MASS MOVEMENT OF SOIL AND ROCK

Table of Contents

	<u>Page</u>
A.1 General	32
A.2 Scope	32
A.3 Design Loads	32
A.3.1 General	32
A.3.2 Soil and Water Loads	33
A.3.3 Surcharge Loads	33
A.3.4 Operational Loads	34
A.3.5 Dynamic Loads	34
A.3.6 Restraint Loads	34
A.4 Design Criteria	34
A.4.1 General	34
A.4.2 Sloped Excavations	34
A.4.3 Braced and Shielded Excavations	35
A.5 Information on Accepted Engineering Practice	38
A.5.1 General	38
A.5.2 References	38
A.5.3 Summary of Information	38

LIST OF SYMBOLS

- B - Width of excavation in ft.
- c - Cohesion (undrained shear strength) of material in bank, lb/ft².
- c_b - Undrained shear strength of material below bottom of excavation, lb/ft².
- D_r - Relative density of soil, percent.
- H - Depth of Excavation, in ft.
- k_a - Coefficient of active earth pressure, as defined by pertinent equations listed.
- m - Coefficient in lateral force equation as defined by Peck (1969) (see Section A.5.2).
- $N = \gamma H/c$ - Stability number, based on shear strength of material in the bank.
- $N_b = \gamma H/c_b$ - Stability number, based on shear strength of material below bottom of excavation and weight of material in bank.
- \bar{N} - Blowcount in standard penetration test using traditional U.S. methods (rope and cathead) in blows per foot.
- S - Load capacity in lb.
- \bar{S} - Average strength (average failure load corrected for load duration, if applicable) in lb.
- v - Coefficient of strength variation.
- γ - Unit weight of soil (in natural condition or as assumed for worst case), in lb/ft³.
- γ_{sat} - Unit weight of saturated soil, in lb/ft³.
- γ_{sub} - Unit weight of submerged soil, in lb/ft³.
- γ_w - Unit weight of water in lb/ft³.
- ϕ - Angle of shearing resistance (internal friction) of soil, in degrees.

A.1 GENERAL

These guidelines are for engineers who design shoring systems, trench shields, and trench boxes or determine sideslopes in excavations. The guidelines are not meant to be a standard from which an engineer cannot deviate. Rather, they recommend minimum design loads and safety margins against mass soil and rock movement which are considered appropriate, and design limit states which should be considered by engineers. It is recognized that the design of shoring systems, the stability analysis of slopes, and the assessment of soil conditions are not an exact science which can be approached with a set of rigid rules, but rather an art which requires judgment, experience and recognition of unique local conditions. Thus these guidelines can neither be imposed as mandatory rules, nor can a professional engineer forego his responsibility to determine in each instance whether the stated guidelines are adequate.

A.2 SCOPE

The guidelines contain recommended minimum requirements for the protection of workers in excavations against death and injury by mass movement of soil and rock. They do not cover other important parameters which an engineer must consider, such as protection of adjacent structures, utilities and improvements against damaging settlements, or effects of ground water fluctuations on adjacent properties. They also do not cover other safety requirements in excavations which are unrelated to soil and rock movement.

Three methods of preventing soil and rock movement are considered in the guidelines: sloping of the banks of excavations; shoring; and shielding of the work space by protective devices. Other methods could also be used such as soil stabilization by freezing or grouting. The guidelines do not apply to excavations whose collapse does not endanger workers.

A.3 DESIGN LOADS

A.3.1 General

All the design loads listed, but not necessarily only the listed loads, should be considered. Unless specifically stated otherwise in the design criteria, the most critical combination of design loads should be considered. The design loads quantified herein are "working loads" (see definition). The design loads apply to shoring systems as well as protective devices such as trench shields and trench boxes.

A.3.2 Soil and Water Loads

(1) General

Loads caused by soil and water pressures should be calculated in accordance with accepted engineering practice and these guidelines.

(2) Loads Caused by Water

Hydrostatic loads, hydrodynamic loads and seepage forces should be considered where applicable. Special attention should be given to the effects of potential groundwater fluctuations, saturation of previously drained deposits, and water penetration into fissures. The following conditions are recommended as the basis for determining critical loads:

For long-term excavations: conditions caused by the 5-year flood.

For short-term excavations: conditions caused by the 1-year flood or alternatively the most severe condition that will not cause interruption of work and evacuation of the workers from the excavation.

(3) Soil Loads

Soil loads should be determined in accordance with the state of the art in geotechnical engineering. Special attention should be given to fissures, planes or weakness and previously excavated soils. The following conditions are recommended as a basis for determining critical loads.

For long-term excavations: Drained as well as undrained conditions should be considered if applicable. Short-term strength characteristics should not be assumed to contribute to stability. Effects of exposure, lateral expansion, desiccation cracks, freezing, erosion, and change in confining pressures should be taken into account.

For short-term excavations: In most instances only undrained conditions need to be considered. Short-term strength characteristics could be considered, provided that an adequate assessment is made of conditions that could lead to loss of strength.

Further information is provided in Section A.5.

A.3.3 Surcharge Loads

Surcharge loads should be determined on the basis of actual anticipated working conditions. Consideration should be given to: the amount and location of accumulated spoil material; stored construction material; construction equipment; vehicular and human traffic; and foundations adjacent to the excavation.

In no case shall the surcharge load be assumed less than 200 lb/ft² distributed over the entire ground surface or the equivalent of an additional 2 ft. depth of material excavated on the site (using average unit weight of soil deposits), whichever is more.

A.3.4 Operational Loads

All loads caused by the anticipated excavation work must be considered. These include excavated or construction material supported by portions of the shoring

system and workers climbing on the shoring system. The following minimum load shall be used for design: a gravity load of 240 lb distributed over any 1 ft. long portion of any strut.

A.3.5 Dynamic Loads

Dynamic loads which can reasonably be anticipated as a result of pile driving, blasting, vehicular traffic and construction equipment should be considered.

In addition, trench shields, trench boxes and shoring systems installed by methods which do not assure that the sheeting bears tightly against the excavation wall (there may be an open space between the bank and the sheeting) should withstand without failure an impact energy of 240 ft-lb applied at any point against the sheeting side facing the bank (inward). Only in shoring systems whose struts are pre-loaded the sheeting should be assumed to bear tightly against the excavation wall.

A.3.6 Restraint Loads

Restraint loads caused by temperature, moisture, or other factors causing dimensional changes in structural members of the shoring system should be considered when applicable. In general, it can be assumed that the empirically based lateral loads calculated in accordance with present engineering practice contain a reasonable allowance for temperature effects on struts.

A.4 DESIGN CRITERIA

A.4.1 General

This section conveys design limit states and design criteria. "Design limit states" are events which constitute a failure to meet safety requirements. "Design criteria" are design rules such as factors of safety to be used which, if followed, will reduce the probability of occurrence of the design limit states to acceptable levels. It is conceivable that an engineer could deviate from the design criteria if the occurrence of the design limit states can be prevented by other means.

A.4.2 Sloped Excavations

(1) Design Limit States:

1. Slope stability failure (part or all of the embankment)
2. Sloughing

(2) Design Criteria:

1. Long-term Excavations

- (a) Granular soils (no cohesion):
Slope angle should not exceed angle of shearing resistance.
- (b) Cohesive Soils:
The safety factor against stability failure should be greater than 1.5, unless the excavation is monitored by an engineer using instrumentation and other means. The safety factor should always be greater than 1.3. Suitable surface and subsurface drainage should be provided to prevent stability failures or sloughing induced by seepage or erosion.

Maximum unbraced height of vertical bank:

5 ft. for all soils or fractured rock. No limitation for unfractured rock.^{1/}

2. Short-term Excavations

The safety factor against stability failure should exceed 1.3 except that for dry cohesionless soils a slope angle equal to the angle of shearing resistance may be maintained. Short-term strength properties could be utilized, provided that there are adequate safeguards against conditions which could cause strength degradation.

Maximum unbraced vertical bank: For intact hard clays and loess the unbraced height could exceed 5 ft provided that an engineer can document that there is substantial empirical evidence that the unsupported bank will stand without failure. For all other soils, including fractured rock, the maximum unbraced height should not exceed 5 ft. There are no limitations for unfractured rock.

A.4.3 Braced and Shielded Excavations

(1) Design Limit States

- 1. Stability failure of the bank.
- 2. Base instability.
- 3. Partial caving or sloughing of the bank between spaced vertical or horizontal supports.

^{1/} A geotechnical engineer or engineering geologist should determine whether the rock is unfractured.

4. Failure of the soil supporting struts, anchors, or soldier piles.
5. Failure of structural components of the shoring system or of protective devices.

(2) Design Criteria

1. Stability of the Bank

A stability failure of the bank is the collapse of all or part of the bank caused by sliding of a soil mass along a failure surface. The failure surface may lie outside the support points of structural members of the shoring systems (supports of raker braces, soil anchors, or the bottom of soldier piles or cantilever sheeting) and thus render the shoring ineffective, or it may be caused by the structural failure of members of the shoring system.

The safety factor against any stability failure of the bank should exceed 1.5.

2. Base Stability

Base instability leads to heaving of the base of the excavation, which in turn can cause dislocation and collapse of the shoring system. The safety factor against base instability should exceed 1.5. Potential effects of uplift resulting from artesian pressure in confined aquifers should be considered. Dewatering should be adequate to prevent piping (quick condition) caused by seepage of groundwater into the base of the excavation. In deep clay deposits, base instability should be considered a problem whenever N_b exceeds the following values: $N_b > 6$ for trenches where $\frac{H}{B} > 3$; $N_b > 5.14$

for very wide excavations: intermediate values for $0 < \frac{H}{B} \leq 3$.

where $N_b = \gamma H / c_b =$ stability number for base failure.

$\gamma =$ unit weight of soil, lb/ft³

$H =$ depth of excavation, ft.

$B =$ width of excavation, ft.

$c_b =$ undrained shear strength below excavation base, lb/ft²

3. Soil Stability between Spaced Supports

There is no generally accepted theoretical approach by which the ability of a soil to arch between successive supports can be evaluated or correlated with strength properties of the soil. There is empirical evidence that short-term supports can be spaced up to 8 ft. on center in hard clay, very stiff sandy clays or glacial tills, and 2 to 3 ft. on center in slightly fissured clays.

Guidance is given in Section 1926.652(b)(4)(iv) and should be compared with empirical field evidence.

4. Soil Support for Struts, Anchors or Soldier Piles

A minimum safety factor of 2 is recommended against bearing failures of members of the shoring systems such as raker braces. A safety factor against shear failure of the supporting soil of not less than 1.5 should be used when passive earth pressure is relied upon to support embedded portions of soldier piles and sheeting or deadmen.

All soil anchors should be proof load tested to 1.33 times their working load. If the load capacity of soil anchors is determined by tests, it should be not less than 1.5 times the working load for anchor inclinations of 2 hor.:1 vert. or flatter, and increase to 2.0 times their working load for inclinations of 1 hor.:2 vert. When anchor capacity is determined by analysis the safety factor should not be less than 3. Soil anchors subjected to the working load should not show creep when the load is sustained for 15 minutes.

5. Design of Structural Components of Shoring Systems, Trench Shields and Trench Boxes

(a) Applicable Standards

See Section 2.5.

(b) Allowable Stresses

Allowable stresses should be determined in accordance with the applicable standards. In long-term excavations allowable stresses should not be exceeded under any applicable combination of working loads. In short-term excavations allowable stresses in structural members may be exceeded by up to 33 percent.

(c) Ultimate Strength Design

Ultimate strength, rather than working stress design may be used whenever such a procedure is stipulated in the applicable standard or load capacity is determined by test. Ultimate loads should be taken as 1.7 times the working load for long-term excavations and 1.3 times the working load for short-term excavations, and should not exceed the load capacity as defined in section 2.1B.

(d) Determination of Load Capacity by Test

Determination of the load capacity of structural components of the shoring system by tests should be in accordance with Section 2.4.

A.5 INFORMATION ON ACCEPTED ENGINEERING PRACTICE

A.5.1 General

This section contains a brief summary of information on commonly used engineering practice which is considered to provide adequate protection against the mass movement of soil and rock. The choice of the referenced design approaches should not be interpreted as an endorsement of these approaches over other approaches which are consistent with the present state of the art.

A.5.2 References

The following references provide guidance in the calculation of lateral loads on excavation bracing. Loads calculated in accordance with these references are considered to be working loads:

Department of the Navy, Design Manual, Soil Mechanics, Foundations and Earth Structures, NAVFAC DM-7, Chapter 10, U.S. Naval Publications and Forms Center, Philadelphia, PA, September 1971.

Goldberg, D.T., Jaworski, W.E., and Gordon, M.D., Lateral Support Systems and Underpinning, Report No. FHWA-RD-75-129, Vol. II, Federal Highway Administration, Washington, D.C., April 1976.

Peck, R.B., Deep Excavations in Soft Ground, Proceedings of the International Conference on Soil Mechanics and Foundation Engineering, State-of-the-Art Volume, pp. 225-250, Mexico City, 1969.

Peck, R.B., Hanson, W.E., and Thurnburn, T.H., Foundation Engineering, Chapter 27, John Wiley and Sons, New York, NY, Jan. 1974.

Tschebotarioff, T. P., Foundations, Retaining and Earth Structures, McGraw-Hill New York, NY, 1973.

United States Steel Company, Sheet Piling Manual, U.S. Steel, Pittsburgh, Pa., July 1975.

A.5.3 Summary of Information

Hereafter is a summary of information derived from references in section A.5.2. The suggested pressure envelopes are not intended as an endorsement of one single approach to the problem, but rather as a summary of commonly used approaches.

(1) Lateral Pressures

1 Sands (Peck, 1969)

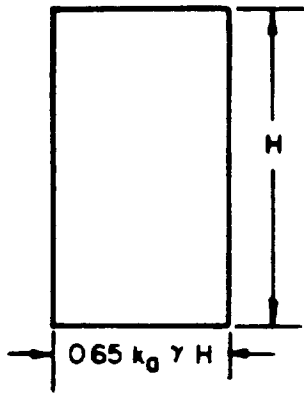

$$k_a = \tan^2 (45 - \phi/2)$$

2. Soft to Medium Clays, when $N > 6$ (Peck, 1969) (if pressures calculated under 3 using $0.4 \gamma H$ are larger, use (3)).

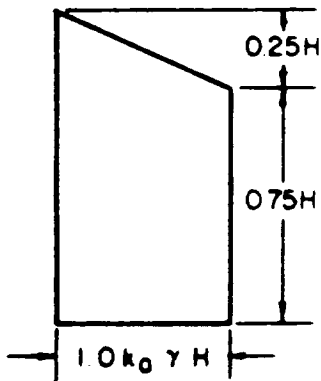

$$N = \gamma H / C$$

$$k_a = 1 - m \frac{4}{N}$$

When cut is underlain by deep, soft, normally consolidated clays: $m = 0.4$
All other cases: $m = 1.0$

3. Stiff Clays, whenever $N < 4$. (Peck, 1969) (if $4 < N < 6$ use 2. or 3., whichever gives larger pressures)

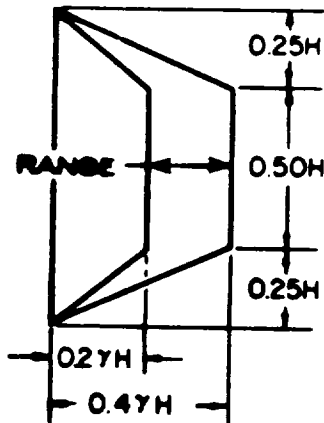

4. Dense cohesive sands, very stiff sandy clays. (Goldberg et al., 1976)

Relatively Uniform

Upper Third of Cut
Dominated by Cohesionless Sands

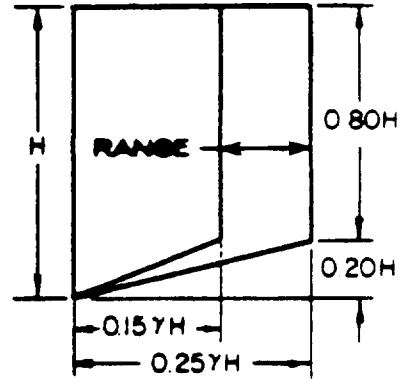
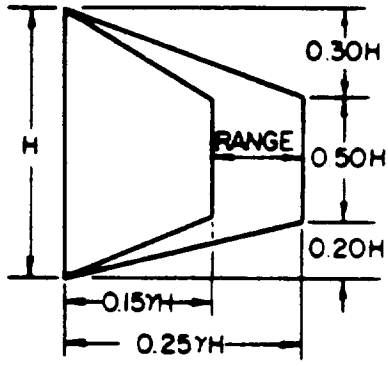

(2) Soil Properties

TABLE A.1. Typical Values of Unit Weight of Soils

Silty or clayey sands & gravel Soil Type	Moist U.W. above W.T., γ (lb/ft ³)	Saturated U.W. Below W.T., γ_{sat} (lb/ft ³)
Poorly graded sand	105-115	115-125
Clean well graded sands	115-125	125-130
Silty or clayey sands	120-130	125-135
Silty or clayey sands & gravel	125-135	130-145
Soft to medium clay	100-115	100-115
Stiff to very stiff clay	110-125	110-125
Organic silt or clay	90-100	90-100

$$\gamma_{sub} = \gamma_{sat} - \gamma_w$$

$$\gamma_w = 62.4 \text{ lb/ft}^3$$

TABLE A.2. Relationship Between Properties of Cohesionless Soil and Standard Penetration Test Results

Soil Type	SPT, \bar{N} blows/ft.	Relative Density $D_r\%$	ϕ (after Peck)	k_a
Very loose sand	<4	0-15	29°	>0.35
Loose sand	4-10	15-35	29°-30°	0.35-0.33
Medium dense sand	10-30	35-65	30°-36°	0.33-0.25
Dense sand	30-50	65-85	36°-41°	0.25-0.21
Very dense sand	>50	85-100	>41°	<0.21

TABLE A.3. Properties of Cohesive Soil and Standard Penetration Test Results

Clay Consistency	Identification	SPT, \bar{N} blows/ft.	Shear Str. lb/ft ²	Compr. Str. lb/ft ²
Very soft	Easily penetrated several inches by fist. Extrudes between fingers when squeezed in hand.	<2	250	<500
Soft	Easily penetrated several inches by thumb. Molded by light finger pressure.	2-4	250-500	500-1000
Medium	Can be penetrated several inches by thumb with moderate effort. Molded by strong finger pressure.	4-8	500-1000	1000-2000
Stiff	Readily indented by thumb but penetrated only with great effort.	8-15	1000-2000	2000-4000
Very stiff	Readily indented by thumbnail.	15-30	2000-4000	4000-8000
Hard	Indented with difficulty.	>30	>4000	>8000

The correlation between \bar{N} values and soil properties for clays can be regarded as no more than a crude approximation, but for sands it is often reliable enough to permit the use of \bar{N} values in design. Unconfined compression tests or tri-axial tests are more reliable for clays. It should also be noted that the value of \bar{N} can be influenced by numerous factors such as: the depth at which the test is made; the location of the water table; presence of boulders in the deposits; irregularities in performing the test; etc. In general, \bar{N} values used here are representatives of those obtained by the traditional U.S. (rope and cathead) methods. If other methods are used, a correction for delivered energy is desirable.

APPENDIX B. INFORMATION ON ACCEPTABLE SHORING SYSTEMS

B.1 Timber Shoring

- (a) Examples of acceptable timber shoring sizes for mixed hardwoods II (see Table 1, page 27) are given in Tables B.1, B.2, B.3 and B.4. Other sizes and arrangements can be used if they comply with the provisions in Subpart P.
- (b) Timber sheeting (except plywood) shall have a minimum thickness of 2 in. in Type A and B soils and 3 in. in Type C soils. In trenches more than 15 ft. deep, all timber sheeting shall have a minimum thickness of 3 in.

Table B.1. Spaced Timber Sheeting in Accordance with Standard Practice (Strut Wale Assemblies for trenches 4 ft. or less wide).

Trench Depth (ft)	Soil Type	Strut Sizes (in)			Sizes of Upright (in)					Wale Sizes (in)
		Horizontal Spacing (ft)			Horizontal Spacing (ft)					
		4	6	8	2	3	4	6	8	
5-10	A		4 x 4	4 x 4				2 x 6	2 x 8	
10-15	A	4 x 4	4 x 4				2 x 6	3 x 8		
5-10	B		4 x 6			2 x 6				6 x 8
10-15	B		6 x 6		2 x 6					8 x 8
10-15	B	4 x 6			2 x 6					6 x 6

- Notes: (1) All lumber sizes are actual (not nominal) sizes in inches.
- (2) 3 x 6 struts can be substituted for 4 x 4 struts in trenches up to 4 ft. wide. For trenches wider than 4 ft. use Table B.3 for strut size adjustment.
- (3) All horizontal spacing is center-to-center.
- (4) Vertical center-to-center spacing of struts or wales not to exceed 4 ft.
- (5) Longer side of wale cross section to be horizontal.
- (6) Spaced sheeting is not allowed in Type C soils.

Table B.2. Timber Shoring Strut Sizes for Strut-Wale Assemblies, in Accordance with Standard Practice (for trenches 4 ft. or less wide)

Trench Depth (ft)	Soil Type	Horizontal Strut Spacing (ft)						
		6	8	10	12	14	16	20
5-10	B	4 x 6	6 x 6	6 x 6	8 x 8	8 x 8	8 x 10	10 x 10
	C	6 x 8	8 x 8	8 x 10	8 x 10	10 x 10	10 x 12	12 x 12
10-15	B	6 x 6	6 x 8	8 x 8	8 x 10	10 x 10	10 x 12	12 x 12
	C	8 x 8	8 x 10	10 x 10	10 x 12	12 x 12		
15-20	B	6 x 8	8 x 8	8 x 10	10 x 10	10 x 12	12 x 12	
	C	8 x 10	10 x 12	12 x 12				

- (1) All lumber sizes are actual (not nominal) sizes in inches.
- (2) For trenches wider than 4 ft. adjust strut sizes by Table B.3.
- (3) Vertical spacing not to exceed 5 ft. center-to-center.
- (4) All horizontal spacing is center-to-center.

Table B.3. Adjustment of Strut Size for Trench Width

Adjustment of Strut Size for Excavation Width				
Strut Size from Table B.1 or B.2	Size of Strut Required for Trench Widths			
4 ft	6 ft	9 ft	12 ft	15 ft
4 x 4	4 x 4	4 x 6	6 x 6	6 x 6
4 x 6	4 x 6	6 x 6	6 x 6	6 x 6
6 x 6	6 x 6	6 x 6	6 x 8	8 x 8
6 x 8	6 x 8	6 x 8	8 x 8	8 x 8
8 x 8	8 x 8	8 x 8	8 x 8	8 x 10
8 x 10	8 x 10	8 x 10	8 x 10	10 x 10

- Notes: (1) Blanks indicate no adjustment in size required.
 (2) 10 x 10 or larger sizes need no adjustment.

Table B.4. Timber Shoring Wale Sizes in Accordance with Standard Practice

Trench Depth (ft)	Soil Type	Horizontal Strut Spacing (ft)							Sheeting Thickness (in)
		6	8	10	12	14	16	20	
5-10	B	6 x 8	8 x 10	10 x 10	10 x 10	10 x 12	12 x 12		2
	C	8 x 10	10 x 12	12 x 12*	12 x 12				3
10-15	B	8 x 8	10 x 10	10 x 12*	10 x 12	12 x 12			2
	C	10 x 12	12 x 12*	12 x 12					3
15-20	B	8 x 10	10 x 12	12 x 12*	12 x 12				3
	C	12 x 12	12 x 12						3

←----- USE INTERMEDIATE STRUTS TO THE RIGHT OF LINE

- (1) All lumber sizes are actual (not nominal) sizes in inches.
- (2) Vertical spacing not to exceed 5 ft. center-to-center.
- (3) All horizontal spacing is center-to-center.
- (4) Long side of cross-section of rectangular members to be horizontal.
- (5) * indicates slight overstress.
- (6) Wale sizes to the right of dividing line require insertion of intermediate strut before workers enter the trench.
- (7) If vertical distance from the center of the lowest wale to the bottom of the trench exceeds 2 1/2 ft., sheeting shall be firmly embedded below the bottom of the trench or mudsill shall be used. The vertical distance from the center of the lowest wale to the bottom of the trench shall not exceed 3 ft., or 3 1/2 ft. if mudsill is used.

B.2. CHARTS FOR THE SELECTION OF RATED SHORING SYSTEMS

CHART 1: Strut Loads for 5 Ft. Vertical Strut Spacing

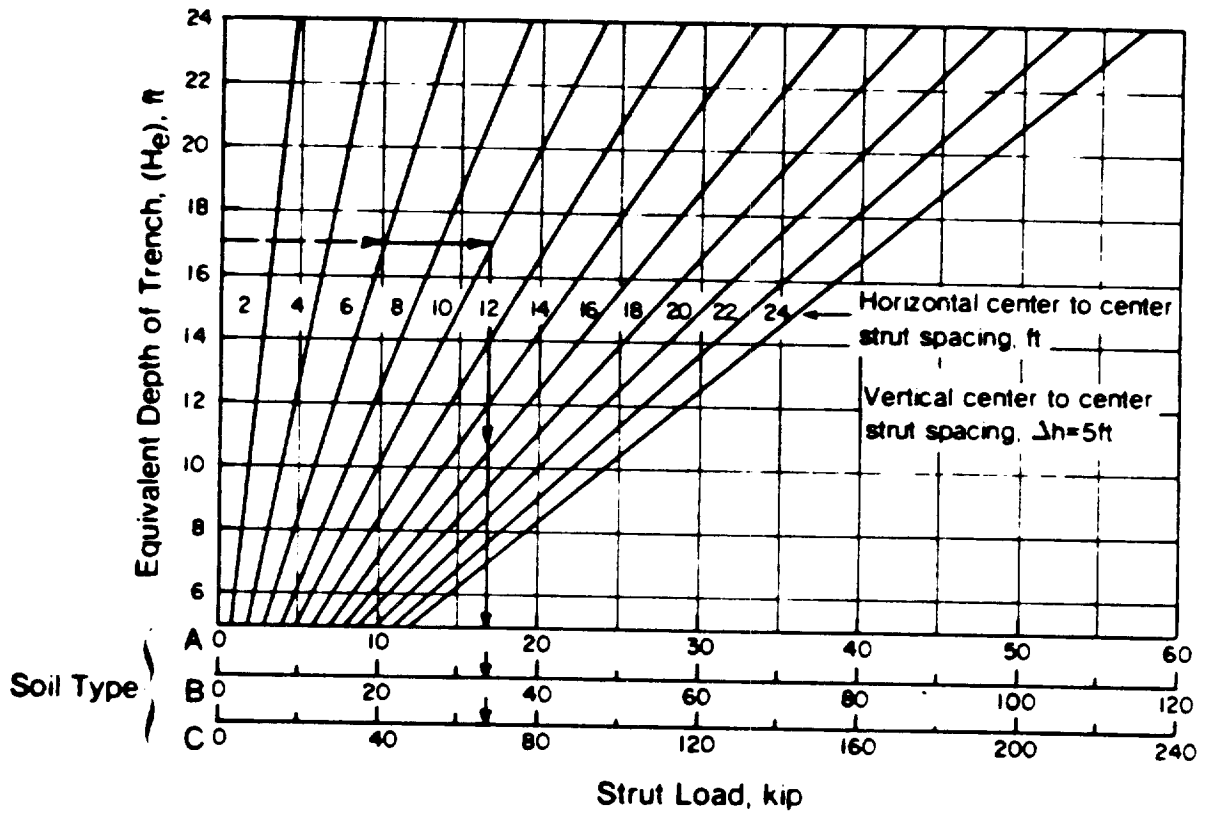

EXAMPLE: (following arrows)

Equivalent Depth: 17 ft.
Horizontal Strut Spacing: 10 ft.

Strut Loads:
Type A Soil 17 kip
Type B Soil 34 kip
Type C Soil 68 kip

CHART 2: Strut Loads for 4 Ft. Vertical Strut Spacing

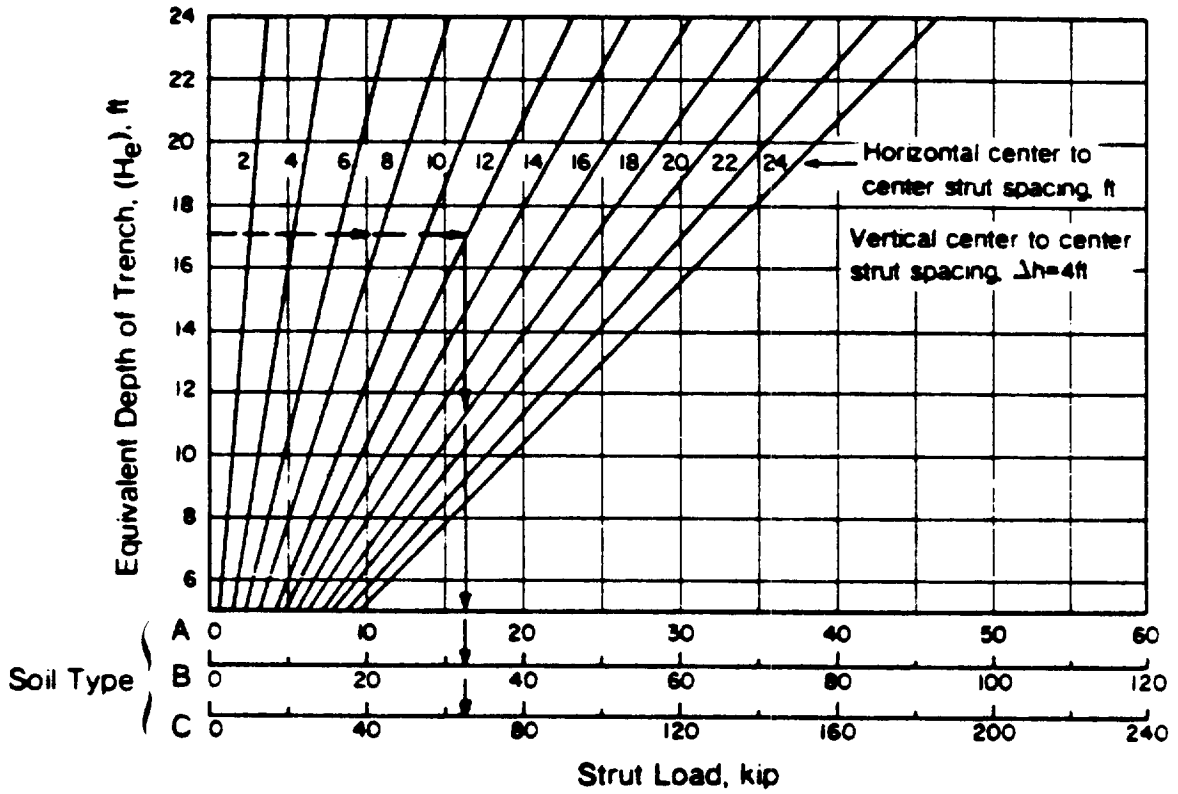

EXAMPLE: (follow arrows)

Equivalent Depth: 17 ft.
Horizontal Strut Spacing: 12 ft.

Strut Loads:
Type A Soil 16.3 kip
Type B Soil 32.6 kip
Type C Soil 65.3 kip

CHART 3: Wale Loads in Kip Per Foot of Length

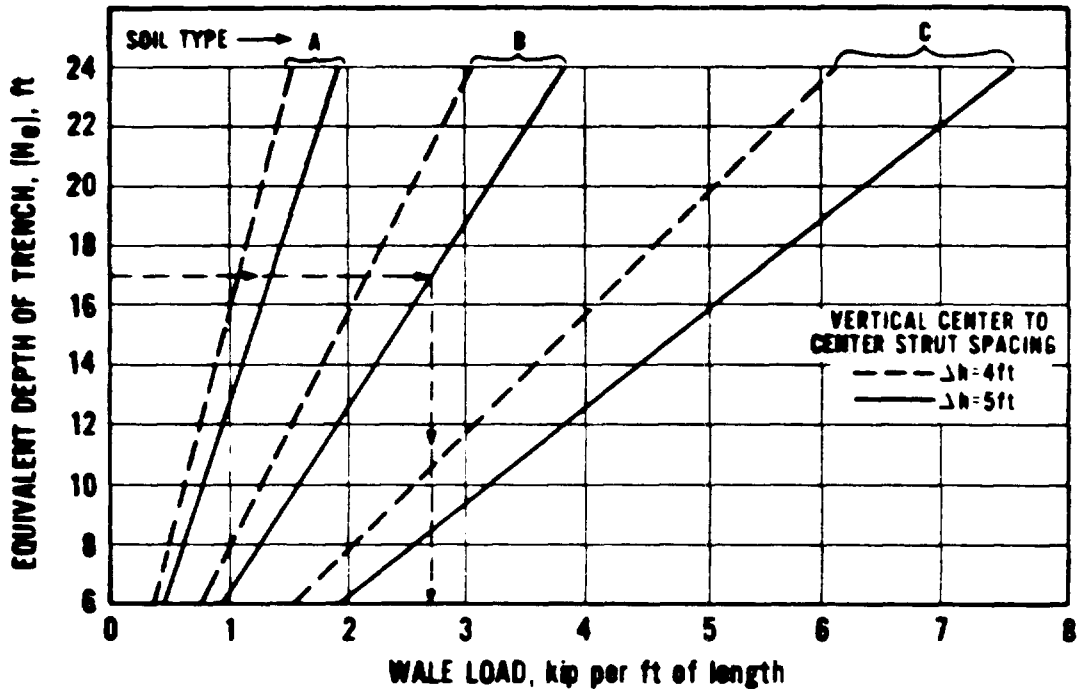

EXAMPLE: (follow arrows)

Equivalent Depth: 17 ft.

Type B Soil Vertical Spacing: 5 ft.

Wale Load: 2.72 kip per foot of length

CHART 4: Sheet Pile Pressure, lb/ft²

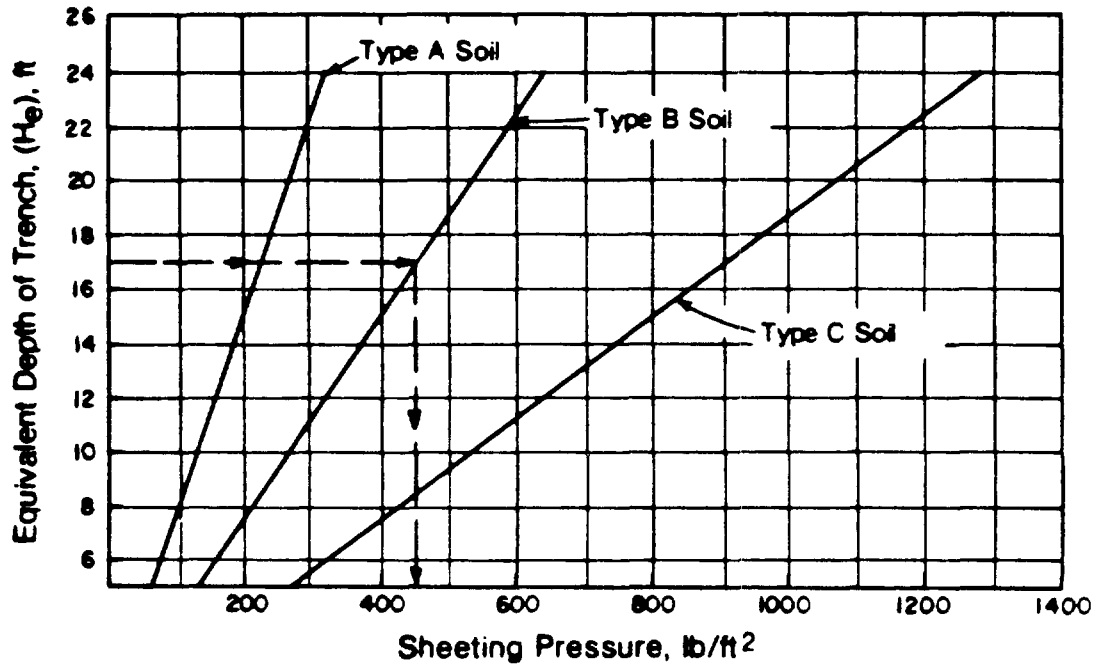

EXAMPLE: (follow arrows)

Equivalent Depth: 17 ft.

Type B Soil

Sheeting Pressure: 460 lb per ft²

Table B.5. Strut Loads in KIP for 5 Ft. Vertical Strut Spacing

Equivalent Depth and Soil Type		Horizontal Strut Spacing, Ft.									
		2	4	6	8	10	12	14	16	18	20
5 ft. - 10 ft.	A	2	4	6	8	10	12	14	16	18	20
	B	4	8	12	16	20	24	28	32	36	40
	C	6	16	24	32	40	48	56	64	72	80
10 ft. - 15 ft.	A	3	6	9	12	15	18	21	24	27	30
	B	6	12	18	24	30	36	42	48	54	60
	C	12	27	36	48	45	72	84	96	108	120
15 ft. - 20 ft.	A	4	8	12	16	20	24	28	32	36	40
	B	8	16	24	32	40	48	56	64	72	80
	C	16	32	48	64	80	96	112	128	144	160

Table B.6. Wale Loads in KIP Per Ft. of Length of 5 Ft. Vertical Wale Spacing

Trench Depth	Soil Type		
	A	B	C
5 ft. - 10 ft.	.8	1.6	3.2
10 ft. - 15 ft.	1.2	2.4	4.8
15 ft. - 20 ft.	1.6	3.2	6.4

ATTACHMENT
SUMMARY OF RECOMMENDED CHANGES
IN SUBPART P

Subpart P—Excavations, Trenching, and Shoring

1926.650 General protection requirements.

(a) Walkways, runways, and sidewalks shall be kept clear of excavated material or other obstructions and no sidewalks shall be undermined unless shored to carry a minimum live load of one hundred and twenty-five (125) pounds per square foot.

(b) If planks are used for raised walkways, runways, or sidewalks, they shall be laid parallel to the length of the walk and fastened together against displacement.

(c) Planks shall be uniform in thickness and all exposed ends shall be provided with beveled cleats to prevent tripping.

(d) Raised walkways, runways, and sidewalks shall be provided with plank steps on strong stringers. Ramps, used in lieu of steps, shall be provided with cleats to insure a safe walking surface.

(e) All employees shall be protected with personal protective equipment for the protection of the head, eyes, respiratory organs, hands, feet, and other parts of the body as set forth in Subpart E of this part.

(f) Employees exposed to vehicular traffic shall be provided with and shall be instructed to wear warning vests marked with or made of reflectorized or high visibility material.

(g) Employees subjected to hazardous dusts, gases, fumes, mists, or atmospheres deficient in oxygen, shall be protected with approved respiratory protection as set forth in Subpart D of this part.

(h) No person shall be permitted under loads handled by power shovels, derricks, or hoists. To avoid any spillage employees shall be required to stand away from any vehicle being loaded.

(i) Daily inspections of excavations shall be made by a competent person. If evidence of possible cave-ins or slides is apparent, all work in the excavation shall cease until the necessary precautions have been taken to safeguard the employees.

1926.651 Specific excavation requirements.

(a) Prior to opening an excavation, effort shall be made to determine whether underground installations, i.e., sewer, telephone, water, fuel, electric lines, etc., will be encountered, and if so, where such underground installations are located. When the excavation approaches the estimated location of such an installation, the exact location shall be determined and when it is uncovered, proper supports shall be provided for the existing installation. Utility companies shall be contacted and advised of proposed work prior to the start of actual excavation.

(a) Moved to 1926.650 (b), N.C.

(b) Moved to 1926.650 (c), N.C.

(c) Moved to 1926.650 (d), N.C.

(d) Moved to 1926.650 (e), N.C.

(e) Moved to 1926.650 (f), N.C.

(f) Moved to 1926.650 (g), N.C.

(g) Moved to 1926.650 (h), N.C.

(h) Moved to 1926.650 (i), Modified Reason: Purpose of "to avoid spillage" is not clear.

(i) Moved to 1926.650 (j), Modified Reason: Daily inspections are not enough, inspection of dewatering systems was added.

(a) Moved to 1926.651 (a), N.C.

(b) Trees, boulders, and other surface encumbrances, located so as to create a hazard to employees involved in excavation work or in the vicinity thereof at any time during operations, shall be removed or made safe before excavating is begun.

(b) Moved to 1926.651 (b), N.C.

(c) The walls and faces of all excavations in which employees are exposed to danger from moving ground shall be guarded by a shoring system, sloping of the ground, or some other equivalent means.

(c) Deleted

(d) Excavations shall be inspected by a competent person after every rainstorm or other hazard-increasing occurrence, and the protection against slides and cave-ins shall be increased if necessary.

(d) Incorporated in 1926.650, j

(e) The determination of the angle of repose and design of the supporting system shall be based on careful evaluation of pertinent factors such as: Depth of cut; possible variation in water content of the material while the excavation is open; anticipated changes in materials from exposure to air, sun, water, or freezing; loading imposed by structures, equipment, overlying material, or stored material; and vibration from equipment, blasting, traffic, or other sources.

(e) Deleted

(f) Supporting systems, i.e., piling, cribbing, shoring, etc., shall be designed by a qualified person and meet accepted engineering requirements. When tie rods are used to restrain the top of sheeting or other retaining systems, the rods shall be securely anchored well back of the angle of repose. When tight sheeting or sheet piling is used, full loading due to ground water table shall be assumed, unless prevented by weep holes or drains or other means. Additional stringers, ties, and bracing shall be provided to allow for any necessary temporary removal of individual supports.

(f) Deleted

(g) All slopes shall be excavated to at least the angle of repose except for areas where solid rock allows for line drilling or pre-splitting.

(g) Deleted

(h) The angle of repose shall be flattened when an excavation has water conditions, silty materials, loose boulders, and areas where erosion, deep frost action, and slide planes appear.

(h) Deleted

(i) (1) In excavations which employees may be required to enter, excavated or other material shall be effectively stored and retained at least 2 feet or more from the edge of the excavation.

(i) Moved to 1926.651 (c), N.C.

(2) As an alternative to the clearance prescribed in subparagraph (1) of this paragraph, the employer may use effective barriers or other effective retaining devices in lieu thereof in order to prevent excavated or other materials from falling into the excavation.

(j) Sides, slopes, and faces of all excavations shall meet accepted engineering requirements by scaling, benching, barricading,

(j) Deleted

rock bolting, wire meshing, or other equally effective means. Special attention shall be given to slopes which may be adversely affected by weather or moisture content.

(k) Support systems shall be planned and designed by a qualified person when excavation is in excess of 20 feet in depth, adjacent to structures or improvements, or subject to vibration or ground water.

(l) Materials used for sheeting, sheet piling, cribbing, bracing, shoring, and underpinning shall be in good serviceable condition, and timbers shall be sound, free from large or loose knots, and of proper dimensions.

(m) Special precautions shall be taken in sloping or shoring the sides of excavations adjacent to a previously backfilled excavation or a fill, particularly when the separation is less than the depth of the excavation. Particular attention also shall be paid to joints and seams of material comprising a face and the slope of such seams and joints.

(n) Except in hard rock, excavations below the level of the base of footing of any foundation or retaining wall shall not be permitted, unless the wall is underpinned and all other precautions taken to insure the stability of the adjacent walls for the protection of employees involved in excavation work or in the vicinity thereof.

(o) If the stability of adjoining buildings or walls is endangered by excavations, shoring, bracing, or underpinning shall be provided as necessary to insure their safety. Such shoring, bracing, or underpinning shall be inspected daily or more often, as conditions warrant, by a competent person and the protection effectively maintained.

(p) Diversion ditches, dikes, or other suitable means shall be used to prevent surface water from entering an excavation and to provide adequate drainage of the area adjacent to the excavation. Water shall not be allowed to accumulate in an excavation.

(q) If it is necessary to place or operate power shovels, derricks, trucks, materials, or other heavy objects on a level above and near an excavation, the side of the excavation shall be sheet-piled, shored, and braced as necessary to resist the extra pressure due to such superimposed loads.

(r) Blasting and the use of explosives shall be performed in accordance with Subpart U of this part.

(s) When mobile equipment is utilized or allowed adjacent to excavations, substantial stop logs or barricades shall be installed. If possible, the grade should be away from the excavation.

(t) Adequate barrier physical protection shall be provided at all remotely located excavations. All wells, pits, shafts, etc., shall be barricaded or covered. Upon completion of exploration and

(k) Deleted - Replaced by 1926.652(a).

(l) Deleted - Reason: redundant see 1926.651(n).

(m) Deleted - Replaced by 1926.652(b), Table 1.

(n) Deleted - Replaced by 1926.652(a), Fig. 1.

(o) Deleted - Replaced by 1925.652(a), Fig. 1.

(p) Moved to 1926.651 (d), modified. Reason: Excavation below water should not be prohibited.

(q) Moved to 1926.651 (e), modified. Reason: Simplified.

(r) Moved to 1926.651 (f), N.C.

(s) Moved to 1926.651 (g), N.C.

(t) Moved to 1926.651 (h), N.C.

similar operations, temporary wells, pits, shafts, etc., shall be backfilled.

(u) If possible, dust conditions shall be kept to a minimum by the use of water, salt, calcium chloride, oil or other means.

(v) In locations where oxygen deficiency or gaseous conditions are possible, air in the excavation shall be tested. Controls, as set forth in Subparts D and E of this part, shall be established to assure acceptable atmospheric conditions. When flammable gases are present, adequate ventilation shall be provided or sources of ignition shall be eliminated. Attended emergency rescue equipment, such as breathing apparatus, a safety harness and line, basket stretcher, etc., shall be readily available where adverse atmospheric conditions may exist or develop in an excavation.

(w) Where employees or equipment are required or permitted to cross over excavations, walkways or bridges with standard guardrails shall be provided.

(x) Where ramps are used for employees or equipment, they shall be designed and constructed by qualified persons in accordance with accepted engineering requirements.

(y) All ladders used on excavation operations shall be in accordance with the requirements of Subpart L of this part.

(u) Moved to 1926.651 (i), N.C.

(v) Moved to 1926.651 (j), N.C.

(w) Moved to 1926.651 (k), N.C.

(x) Moved to 1926.651 (l), Modified.
Reason: Earth or rockfill ramps should be exempted.

(y) Moved to 1926.651 (m), N.C.

1926.652 Specific trenching requirements.

(a) Banks more than 5 feet high shall be shored, laid back to a stable slope, or some other equivalent means of protection shall be provided where employees may be exposed to moving ground or cave-ins. Refer to Table P-1 as a guide in sloping of banks. Trenches less than 5 feet in depth shall also be effectively protected when examination of the ground indicates hazardous ground movement may be expected.

(b) Sides of trenches in unstable or soft material, 5 feet or more in depth, shall be shored, sheeted, braced, sloped, or otherwise supported by means of sufficient strength to protect the employees working within them. See Tables P-1, P-2 (following paragraph (g) of this section).

(c) Sides of trenches in hard or compact soil, including embankments, shall be shored or otherwise supported when the trench is more than 5 feet in depth and 8 feet or more in length. In lieu of shoring, the sides of the trench above the 5-foot level may be sloped to preclude collapse, but shall not be steeper than a 1-foot rise to each ½-foot horizontal. When the outside diameter of a pipe is greater than 6 feet, a bench of 4-foot minimum shall be provided at the toe of the sloped portion.

(a) Deleted - Replaced by 1926.652(a).

(b) Deleted - Replaced by 1926.652(a).

(c) Deleted - Replaced by 1926.652(a).

(d) Materials used for sheeting and sheet piling, bracing, shoring, and underpinning, shall be in good serviceable condition, and timbers used shall be sound and free from large or loose knots, and shall be designed and installed so as to be effective to the bottom of the excavation.

(e) Additional precautions by way of shoring and bracing shall be taken to prevent slides or cave-ins when excavations or trenches are made in locations adjacent to backfilled excavations, or where excavations are subjected to vibrations from railroad or highway traffic, the operation of machinery, or any other source.

(f) Employees entering bell-bottom pier holes shall be protected by the installation of a removable-type casing of sufficient strength to resist shifting of the surrounding earth. Such temporary protection shall be provided for the full depth of that part of each pier hole which is above the bell. A lifeline, suitable for instant rescue and securely fastened to a shoulder harness, shall be worn by each employee entering the shafts. This lifeline shall be individually manned and separate from any line used to remove materials excavated from the bell footing.

(g) (1) Minimum requirements for trench timbering shall be in accordance with Table P-2.

(2) Braces and diagonal shores in a wood shoring system shall not be subjected to compressive stress in excess of values given by the following formula:

$$S = 1300 - \frac{20L}{D}$$
$$\text{Maximum ratio } \frac{L}{D} = 50$$

Where:

L = Length, unsupported, in inches.

D = Least side of the timber in inches.

S = Allowable stress in pounds per square inch of cross-section.

(h) When employees are required to be in trenches 4 feet deep or more, an adequate means of exit, such as a ladder or steps, shall be provided and located so as to require no more than 25 feet of lateral travel.

(i) Bracing or shoring of trenches shall be carried along with the excavation.

(j) Cross braces or trench jacks shall be placed in true horizontal position, be spaced vertically, and be secured to prevent sliding, falling, or kickouts.

(d) Moved to 1926.651 (n), Modified.
Reason: More specific requirement substituted.

(e) Deleted - Replaced by 1926.652(b), Table 1.

(f) Moved to 1926.651 (o), N.C.

(g) Deleted - Replaced by 1926.652(b) and Guidelines, Appendix B.

(h) Moved to 1926.651 (p), Modified.
Reason: Negotiable slope added as means of exit.

(i) Moved to 1926.651 (q), Modified.
Reason: Intent of requirement not clear.

(j) Moved to 1926.651 (r), Modified.
Reason: More general statement needed.

(k) Portable trench boxes or sliding trench shields may be used for the protection of personnel in lieu of a shoring system or sloping. Where such trench boxes or shields are used, they shall be designed, constructed, and maintained in a manner which will provide protection equal to or greater than the sheeting or shoring required for the trench.

(l) Backfilling and removal of trench supports shall progress together from the bottom of the trench. Jacks or braces shall be released slowly and, in unstable soil, ropes shall be used to pull out the jacks or braces from above after employees have cleared the trench.

(k) Moved to 1926.651 (s), Modified.
Reason: Simplified.

(l) Moved to 1926.651 (t)

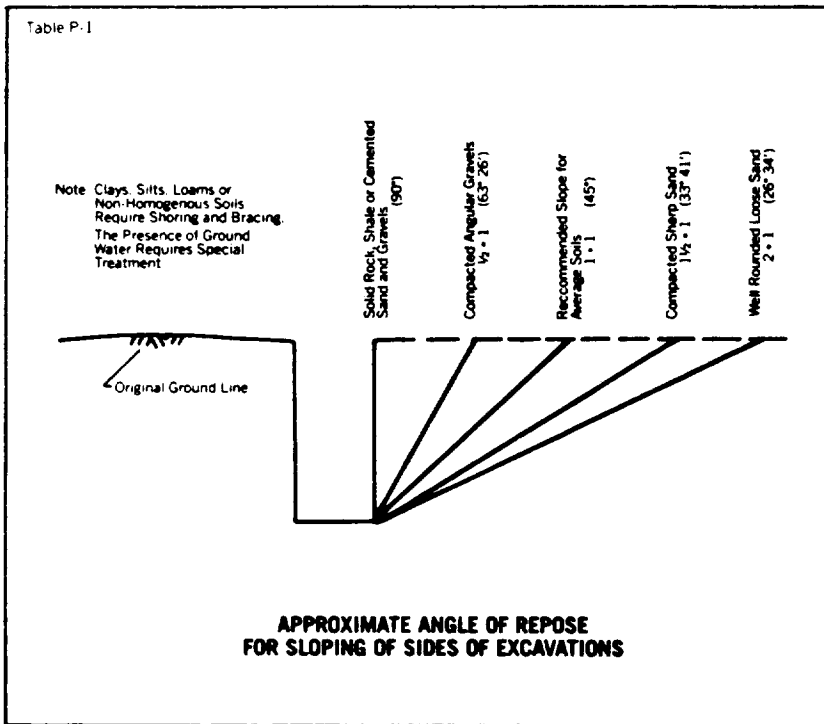

Table P-1

Deleted - Reason: Replaced by 1926.652, Table 1.

Table P-2
TRENCH SHORING - MINIMUM REQUIREMENTS

Depth of trench	Kind or condition of earth	Size and spacing of members										
		Uprights		Stringers		Cross braces ¹				Maximum spacing		
		Minimum dimension	Maximum spacing	Minimum dimension	Maximum spacing	Width of trench				Vertical	Horizontal	
Feet	Inches	Feet	Inches	Feet	Inches	Inches	Inches	Inches	Inches	Feet	Feet	
5 to 10	Hard, compact	3 x 4 or 2 x 6	6			2 x 6	4 x 4	4 x 6	6 x 6	6 x 8	4	6
	Likely to crack	3 x 4 or 2 x 6	3	4 x 6	4	2 x 6	4 x 4	4 x 6	6 x 6	6 x 8	4	6
	Soft, sandy, or filled	3 x 4 or 2 x 6	Close sheeting	4 x 6	4	4 x 4	4 x 6	6 x 6	6 x 8	8 x 8	4	6
	Hydrostatic pressure	3 x 4 or 2 x 6	Close sheeting	6 x 8	4	4 x 4	4 x 6	6 x 6	6 x 8	8 x 8	4	6
10 to 15	Hard	3 x 4 or 2 x 6	4	4 x 6	4	4 x 4	4 x 6	6 x 6	6 x 8	8 x 8	4	6
	Likely to crack	3 x 4 or 2 x 6	2	4 x 6	4	4 x 4	4 x 6	6 x 6	6 x 8	8 x 8		6
	Soft, sandy, or filled	3 x 4 or 2 x 6	Close sheeting	4 x 6	4	4 x 6	6 x 6	6 x 8	8 x 8	8 x 10	4	6
	Hydrostatic pressure	3 x 6	Close sheeting	8 x 10	4	4 x 6	6 x 6	6 x 8	8 x 8	8 x 10	4	6
15 to 20	All kinds or conditions	3 x 6	Close sheeting	4 x 12	4	4 x 12	6 x 8	8 x 8	8 x 10	10 x 10	4	6
Over 20	All kinds or conditions	3 x 6	Close sheeting	6 x 8	4	4 x 12	8 x 8	8 x 10	10 x 10	10 x 12	4	6

¹ Trench jacks may be used in lieu of, or in combination with, cross braces. Shoring is not required in solid rock, hard shale, or hard slag. Where desirable, steel sheet piling and bracing of equal strength may be substituted for wood.

Table P-2 Deleted. Reason: Timber is not the only material used. Revised timber tables are in the Guidelines, Appendix B.

1926.653 Definitions applicable to this subpart.

(a) "Accepted engineering requirements (or practices)"—Those requirements or practices which are compatible with standards required by a registered architect, a registered professional engineer, or other duly licensed or recognized authority.

(b) "Angle of repose"—The greatest angle above the horizontal plane at which a material will lie without sliding.

(c) "Bank"—A mass of soil rising above a digging level.

(d) "Belled excavation"—A part of a shaft or footing excavation, usually near the bottom and bell-shaped; i.e., an enlargement of the cross section above.

(e) "Braces (trench)"—The horizontal members of the shoring system whose ends bear against the uprights or stringers.

(f) "Excavation"—Any manmade cavity or depression in the earth's surface, including its sides, walls, or faces, formed by earth removal and producing unsupported earth conditions by reasons of the excavation. If installed forms or similar structures reduce the depth-to-width relationship, an excavation may become a trench.

(g) "Faces"—See paragraph (k) of this section.

(h) "Hard compact soil"—All earth materials not classified as running or unstable.

(i) "Kickouts"—Accidental release or failure of a shore or brace.

(j) "Sheet pile"—A pile, or sheeting, that may form one of a continuous interlocking line, or a row of timber, concrete, or steel piles, driven in close contact to provide a tight wall to resist the lateral pressure of water, adjacent earth, or other materials.

(k) "Sides," "Walls," or "Faces"—The vertical or inclined earth surfaces formed as a result of excavation work.

(l) "Slope"—The angle with the horizontal at which a particular earth material will stand indefinitely without movement.

(m) "Stringers" (wales)—The horizontal members of a shoring system whose sides bear against the uprights or earth.

(n) "Trench"—A narrow excavation made below the surface of the ground. In general, the depth is greater than the width, but the width of a trench is not greater than 15 feet.

(o) "Trench jack"—Screw or hydraulic type jacks used as cross bracing in a trench shoring system.

(p) "Trench shield"—A shoring system composed of steel plates and bracing, welded or bolted together, which support the walls of a trench from the ground level to the trench bottom and

(a) Modified. Reason: Guidelines are referenced.

(b) Deleted - definition too vague.

(c) Deleted - other definition used.

(d) Moved to 1926.653 (e).

(e) Deleted - other definition used.

(f) Moved to 1926.653 (j), Modified.

(g) Deleted - other definition used.

(h) Deleted - definition not used.

(i) Deleted - definition not used.

(j) Deleted - definition not used.

(k) Moved to 1926.653 (t)

(l) Moved to 1926.653 (u), Modified. Reason: Slope is not defined as angle.

(m) Moved to 1926.653 (cc), Modified. "Stringers" not used.

(n) Deleted - definition not used.

(o) Deleted

(p) Moved to 1926.653 (dd), Modified. Reason: Definition considered inadequate.

which can be moved along as work progresses.

(q) "Unstable soil"—Earth material, other than running, that because of its nature or the influence of related conditions, cannot be depended upon to remain in place without extra support, such as would be furnished by a system of shoring.

(r) "Uprights"—The vertical members of a shoring system.

(s) "Wales"—See paragraph (m) of this section.

(t) "Walls"—See paragraph (k) of this section.

(q) Deleted - not used.

(r) Moved to 1926.653 (ee), Modified.

(s) Moved to 1926.653 (t)

U.S. DEPT. OF COMM. BIBLIOGRAPHIC DATA SHEET <i>(See instructions)</i>	1. PUBLICATION OR REPORT NO.	2. Performing Organ. Report No.	3. Publication Date
4. TITLE AND SUBTITLE Development of Draft Construction Safety Standards for Excavations - Volumes I and II			
5. AUTHOR(S) Felix Y. Yoke1 and Ronald L. Stanevich			
6. PERFORMING ORGANIZATION <i>(If joint or other than NBS, see instructions)</i> NATIONAL BUREAU OF STANDARDS DEPARTMENT OF COMMERCE WASHINGTON, D.C. 20234			7. Contract/Grant No. 8. Type of Report & Period Covered
9. SPONSORING ORGANIZATION NAME AND COMPLETE ADDRESS <i>(Street, City, State, ZIP)</i> Department of Health and Human Services Public Health Service, Center for Disease Control National Institute for Occupational Safety and Health Division of Safety Research, Morgantown, WV 26505			
10. SUPPLEMENTARY NOTES <input type="checkbox"/> Document describes a computer program; SF-185, FIPS Software Summary, is attached.			
11. ABSTRACT <i>(A 200-word or less factual summary of most significant information. If document includes a significant bibliography or literature survey, mention it here)</i> A record of an interim stage in the development of revisions to existing Occupational Safety and Health Administration (OSHA) regulations governing excavations, trenching and shoring practices in the construction industry, Subpart P 29 CFR 1926, is presented. The National Bureau of Standards (NBS) prepared a working draft of recommended changes to the regulations based on previous NBS technical studies. ^{1/} Five regional industry workshops were held to discuss the proposed revisions. Included in the report is a copy of the recommended revisions, which were submitted to the workshops, and a record of industry's response in the form of suggestions, commentary and summaries of workshop activities. The key section of the report presents an analysis of industry response and resulting recommendations. The document is a record intended to aid OSHA during subsequent stages of the rule-making process. ^{1/} Yoke1, F. Y., "Recommended Technical Provisions for Construction Practice in Shoring and Sloping of Trenches and Excavation," NBS Building Science Series 127, June 1980.			
12. KEY WORDS <i>(Six to twelve entries; alphabetical order; capitalize only proper names; and separate key words by semicolons)</i> braced excavations; construction; Federal regulations; retaining structures; safety; shoring; slope stability; soil classification; soil pressures; standards; trenching			
13. AVAILABILITY <input checked="" type="checkbox"/> Unlimited <input type="checkbox"/> For Official Distribution. Do Not Release to NTIS <input type="checkbox"/> Order From Superintendent of Documents, U.S. Government Printing Office, Washington, D.C. 20402. <input checked="" type="checkbox"/> Order From National Technical Information Service (NTIS), Springfield, VA. 22161			14. NO. OF PRINTED PAGES 15. Price

IMPORTANT INFORMATION

Volume II of this report contains background information on the development of the draft standards. This information includes workshop summaries, workshop depositions, source documents and miscellaneous input and information contributed by workshop participants.

Volume II is for sale by the National Technical Information Service, Springfield, Virginia 22151.

DEPARTMENT OF HEALTH AND HUMAN SERVICES
PUBLIC HEALTH SERVICE
CENTERS FOR DISEASE CONTROL
NATIONAL INSTITUTE FOR OCCUPATIONAL SAFETY AND HEALTH
ROBERT A. TAFT LABORATORIES
4676 COLUMBIA PARKWAY CINCINNATI, OHIO 45226

OFFICIAL BUSINESS
PENALTY FOR PRIVATE USE \$300

Special Fourth Class - Book



POSTAGE AND FEES PAID
U.S. DEPARTMENT OF HHS
HHS 396

NBSIR 83-2693
DHHS (NIOSH) Publication No. 83-103