

✓

the INDUSTRIAL ENVIRONMENT
-its EVALUATION and CONTROL

**laboratory
manual**

Syllabus - Volume II

U. S. DEPARTMENT OF HEALTH, EDUCATION, AND WELFARE

Public Health Service

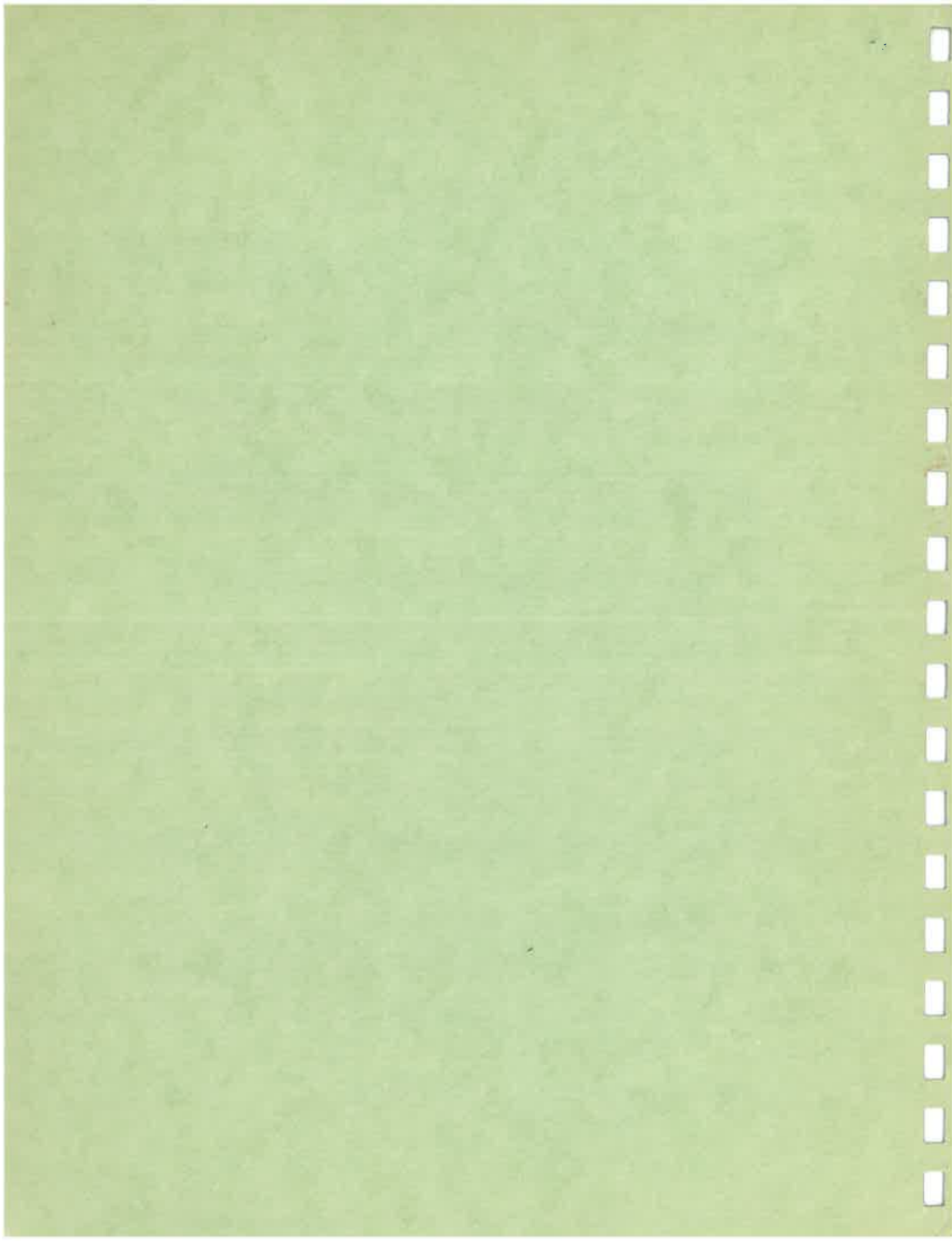

the Industrial Environment
.... its Evaluation and Control

Syllabus - Volume II

LABORATORY MANUAL

Edited by:

*Andrew D. Hosey
Charles H. Powell, Sc.D.*

U.S. DEPARTMENT OF HEALTH, EDUCATION, AND WELFARE

Public Health Service

Division of Occupational Health

PUBLIC HEALTH SERVICE PUBLICATION No. 614

Volume II

UNITED STATES GOVERNMENT PRINTING OFFICE, WASHINGTON: 1966

For sale by the Superintendent of Documents, U.S. Government Printing Office
Washington, D. C., 20402 - Price \$1.50

PREFACE

This publication is a laboratory manual for the 1965 revision of the Syllabus, the Industrial Environment - its Evaluation and Control. It includes laboratory and calibration exercises for both the analytical industrial hygienist and the field industrial health scientist. These procedures and techniques include methods for calibration of instruments and analytical measurement which were not available when the first edition

was published in 1958.

The laboratory exercises supplement instruction offered in the basic training course for the industrial hygiene engineer and chemist new to the field and serve as a review of these methods for many more experienced personnel.

The planning and editing of this edition were done by Mr. Andrew D. Hosey and Dr. Charles H. Powell.

Cincinnati, Ohio
May 1966

TABLE OF CONTENTS

Preface

iii

Section

Conversion Factors and Equivalents

D-1

Mathematical Tables

D-4

 a. Squares and Square Roots

 b. Natural (Napierian) Logarithms

 c. Logarithms to Base 10

Airflow Calibration -

Squeeze-Bulb, Gas and Vapor Detection Systems

E-1

Greenburg-Smith Impinger

E-2

Midget Impinger

E-3

Fixed Flow Electrostatic Precipitator

E-4

Variable Flow Electrostatic Sampler

E-5

Filter Paper Sampler

E-6

High Volume Sampler

E-7

Preparation of Known Concentrations -

Static Method

E-8

Dynamic Method

E-9

Vapor Pressure Method

E-10

Single Chamber Depletion Method

E-11

Laboratory Exercises -

Counting Airborne Dust

E-12

Sizing Airborne Dust

E-13

Chemical Determination of Free Silica

E-14

Determination of Lead in Urine

E-15

Polarographic Determination of Lead, Cadmium and Zinc

E-16

Determination of Approximate Composition of Solvents

E-17

Determination of Sulfur Dioxide

E-18

Sampling and Determination of Methyl Ketones

E-19

Section

Spectrophotometric Determination of Toluenediisocyanate	E-20
Determination of Oxidants (Including Ozone)	E-21
Sampling and Determination of Fluoride	E-22
Determination of Nitrogen Dioxide and Nitric Oxide	E-23
Determination of Aromatic Hydrocarbons	E-24
Noise Measurement and Analysis	E-25
Measurement of Illumination	E-26
Evaluation of Heat Stress	E-27
Determination of Average Air Velocity in a Duct	E-28
Measurement of Pressure Losses in Ductwork	E-29
Effect of Hood Flanges on Coefficient of Entry	E-30
Measurement of Slot and Surface Velocity and Entrance Loss	E-31
Determination of Characteristics of Air Jets	E-32
Flow Through Grilles	E-33

CONVERSION FACTORS AND EQUIVALENTS

1 m ³ = 35.32 ft ³	1 in. of Mercury (Hg.) = 13.57 in. H ₂ O
1 cm ³ = .0610 in ³	1 in. of Hg. = 0.49 lb/in ²
1 ft ³ = 28.32 L.	1 mm. of Hg. = 1.36 cm. of H ₂ O
1 ft ³ = 7.48 gal. (U.S.)	1 atmosphere = 14.70 lb/in ²
1 L = .0353 ft ³	1 atmosphere = 29.92 in. Hg.
1 L = 1000 cm ³	1 atmosphere = 760 mm. Hg.
1 L = 1.057 qts. (U.S. Liquid)	1 Btu = 0.25 large calories
1 m = 3.28 ft.	1 Btu = Heat req'd to raise temp. of
1 m = 39.37 in.	1 lb. of H ₂ O 1°F.
1 m = 10 ⁶ microns	1 Btu = Heat req'd to raise (approx.)
1 in = 25.40 mm.	55 ft ³ of air 1°F.
1 in = 25,400 microns	1 Btu/hr-ft ² = 3.154 x 10 ⁻⁴ watts/cm ²
1 mile/hr = 88 ft/min.	1 Cal/sec-cm ² = 13,263 Btu/hr-ft ²
1 cm/sec = 1.9685 ft/min.	1 Cal/sec-cm ² = 4,183 watts/cm ²
1 Kg = 2.20 lbs.	1 H.P. = 550 ft. lbs/sec.
1 lb = 453.6 grams	1 H.P. = 0.75 Kilowatt
1 oz = 28.35 grams	1 H.P. = 2,545 Btu
1 gram = 15.432 grains	°F = 1.8 (°C.) + 32
1 gram = 10 ³ milligrams	°C = (°F - 32) ÷ 1.8
1 milligram = 10 ³ micrograms	°C = 273° Kelvin (°K)
1 ft ³ of water @ 62°F. weighs 62.32 lb.	°F = 460° Rankine (°R)
1 gal. (U.S.) of water weighs 8.33 lb.	π = 3.1416
1 ft ³ of air at STP weighs 0.075 lb.	Circumference of circle = πd.
1 lb/in ² = 2.30 ft. H ₂ O	Area of circle = πd ² /4
1 gram/cm ³ = 62.43 lbs/ft ³	Surface area of sphere = πd ²
1 gram/cm ³ = 8.345 lbs/gal	Volume of sphere = πd ³ /6

* * * * *

Mathematical Tables

a. Squares and Square Roots

b. Natural (Napierian) Logarithms

c. Logarithms to Base 10

SQUARES AND SQUARE ROOTS

N	N^2	\sqrt{N}	$\sqrt{10N}$	N	N^2	\sqrt{N}	$\sqrt{10N}$	N	N^2	\sqrt{N}	$\sqrt{10N}$
1.00	1.0000	1.00000	3.16228	1.60	2.5600	1.26491	4.06000	2.20	4.8400	1.48324	4.69042
1.01	1.0201	1.00499	3.17805	1.61	2.5921	1.26886	4.01248	2.21	4.8841	1.48661	4.70106
1.02	1.0404	1.00995	3.19374	1.62	2.6244	1.27279	4.02492	2.22	4.9284	1.48997	4.71169
1.03	1.0609	1.01489	3.20936	1.63	2.6569	1.27671	4.03733	2.23	4.9729	1.49332	4.72229
1.04	1.0816	1.01980	3.22490	1.64	2.6896	1.28062	4.04969	2.24	5.0176	1.49666	4.73286
1.05	1.1025	1.02470	3.24037	1.65	2.7225	1.28452	4.06202	2.25	5.0625	1.50000	4.74342
1.06	1.1236	1.02956	3.25576	1.66	2.7556	1.28841	4.07431	2.26	5.1076	1.50333	4.75395
1.07	1.1449	1.03441	3.27109	1.67	2.7889	1.29228	4.08656	2.27	5.1529	1.50667	4.76445
1.08	1.1664	1.03923	3.28634	1.68	2.8224	1.29615	4.09878	2.28	5.1984	1.50995	4.77493
1.09	1.1881	1.04403	3.30151	1.69	2.8561	1.30000	4.11096	2.29	5.2441	1.51327	4.78539
1.10	1.2100	1.04881	3.31662	1.70	2.8900	1.30384	4.12311	2.30	5.2900	1.51658	4.79583
1.11	1.2321	1.05357	3.33167	1.71	2.9241	1.30767	4.13521	2.31	5.3361	1.51987	4.80625
1.12	1.2544	1.05830	3.34664	1.72	2.9584	1.31149	4.14729	2.32	5.3824	1.52315	4.81664
1.13	1.2769	1.06301	3.36155	1.73	2.9929	1.31529	4.15933	2.33	5.4289	1.52643	4.82701
1.14	1.2996	1.06771	3.37639	1.74	3.0276	1.31909	4.17133	2.34	5.4756	1.52971	4.83735
1.15	1.3225	1.07238	3.39116	1.75	3.0625	1.32288	4.18330	2.35	5.5225	1.53297	4.84768
1.16	1.3456	1.07703	3.40588	1.76	3.0976	1.32665	4.19524	2.36	5.5696	1.53623	4.85798
1.17	1.3689	1.08167	3.42053	1.77	3.1329	1.33041	4.20714	2.37	5.6169	1.53948	4.86826
1.18	1.3924	1.08628	3.43511	1.78	3.1684	1.33417	4.21900	2.38	5.6644	1.54272	4.87852
1.19	1.4161	1.09087	3.44964	1.79	3.2041	1.33791	4.23084	2.39	5.7121	1.54596	4.88876
1.20	1.4400	1.09545	3.46410	1.80	3.2400	1.34164	4.24264	2.40	5.7600	1.54919	4.89898
1.21	1.4641	1.10000	3.47851	1.81	3.2761	1.34536	4.25441	2.41	5.8081	1.55242	4.90918
1.22	1.4884	1.10454	3.49285	1.82	3.3124	1.34907	4.26615	2.42	5.8564	1.55563	4.91935
1.23	1.5129	1.10905	3.50714	1.83	3.3489	1.35277	4.27785	2.43	5.9049	1.55885	4.92950
1.24	1.5376	1.11355	3.52136	1.84	3.3856	1.35647	4.28952	2.44	5.9536	1.56205	4.93964
1.25	1.5625	1.11803	3.53553	1.85	3.4225	1.36015	4.30116	2.45	6.0025	1.56525	4.94975
1.26	1.5876	1.12250	3.54965	1.86	3.4596	1.36382	4.31277	2.46	6.0516	1.56844	4.95984
1.27	1.6129	1.12694	3.56371	1.87	3.4969	1.36748	4.32435	2.47	6.1009	1.57162	4.96991
1.28	1.6384	1.13137	3.57771	1.88	3.5344	1.37113	4.33590	2.48	6.1504	1.57480	4.97996
1.29	1.6641	1.13578	3.59166	1.89	3.5721	1.37477	4.34741	2.49	6.2001	1.57797	4.98999
1.30	1.6900	1.14018	3.60555	1.90	3.6100	1.37840	4.35890	2.50	6.2500	1.58114	5.00000
1.31	1.7161	1.14455	3.61939	1.91	3.6481	1.38203	4.37035	2.51	6.3001	1.58430	5.00999
1.32	1.7424	1.14891	3.63318	1.92	3.6864	1.38564	4.38178	2.52	6.3504	1.58745	5.01996
1.33	1.7689	1.15326	3.64692	1.93	3.7249	1.38924	4.39318	2.53	6.4009	1.59060	5.02991
1.34	1.7956	1.15758	3.66060	1.94	3.7636	1.39284	4.40454	2.54	6.4516	1.59374	5.03984
1.35	1.8225	1.16190	3.67423	1.95	3.8025	1.39642	4.41588	2.55	6.5025	1.59687	5.04975
1.36	1.8496	1.16619	3.68782	1.96	3.8416	1.40000	4.42719	2.56	6.5536	1.60000	5.05964
1.37	1.8769	1.17047	3.70135	1.97	3.8809	1.40357	4.43847	2.57	6.6049	1.60312	5.06952
1.38	1.9044	1.17473	3.71484	1.98	3.9204	1.40712	4.44972	2.58	6.6564	1.60624	5.07937
1.39	1.9321	1.17898	3.72827	1.99	3.9601	1.41067	4.46094	2.59	6.7081	1.60935	5.08920
1.40	1.9600	1.18322	3.74166	2.00	4.0000	1.41421	4.47214	2.60	6.7600	1.61245	5.09902
1.41	1.9881	1.18743	3.75500	2.01	4.0401	1.41774	4.48330	2.61	6.8121	1.61555	5.10882
1.42	2.0164	1.19164	3.76829	2.02	4.0804	1.42127	4.49444	2.62	6.8644	1.61864	5.11859
1.43	2.0449	1.19583	3.78153	2.03	4.1209	1.42478	4.50555	2.63	6.9169	1.62173	5.12835
1.44	2.0736	1.20000	3.79473	2.04	4.1616	1.42829	4.51664	2.64	6.9696	1.62481	5.13809
1.45	2.1025	1.20416	3.80789	2.05	4.2025	1.43178	4.52769	2.65	7.0225	1.62788	5.14782
1.46	2.1316	1.20830	3.82099	2.06	4.2436	1.43527	4.53872	2.66	7.0756	1.63095	5.15752
1.47	2.1609	1.21244	3.83406	2.07	4.2849	1.43875	4.54973	2.67	7.1289	1.63401	5.16720
1.48	2.1904	1.21655	3.84708	2.08	4.3264	1.44222	4.56070	2.68	7.1824	1.63707	5.17687
1.49	2.2201	1.22066	3.86005	2.09	4.3681	1.44568	4.57165	2.69	7.2361	1.64012	5.18652
1.50	2.2500	1.22474	3.87298	2.10	4.4100	1.44914	4.58258	2.70	7.2900	1.64317	5.19615
1.51	2.2801	1.22882	3.88587	2.11	4.4521	1.45258	4.59347	2.71	7.3441	1.64621	5.20577
1.52	2.3104	1.23288	3.89872	2.12	4.4944	1.45602	4.60435	2.72	7.3984	1.64924	5.21536
1.53	2.3409	1.23693	3.91152	2.13	4.5369	1.45945	4.61519	2.73	7.4529	1.65227	5.22494
1.54	2.3716	1.24097	3.92428	2.14	4.5796	1.46287	4.62601	2.74	7.5076	1.65529	5.23450
1.55	2.4025	1.24499	3.93700	2.15	4.6225	1.46629	4.63681	2.75	7.5625	1.65831	5.24404
1.56	2.4336	1.24900	3.94968	2.16	4.6656	1.46969	4.64758	2.76	7.6176	1.66132	5.25357
1.57	2.4649	1.25300	3.96232	2.17	4.7089	1.47309	4.65833	2.77	7.6729	1.66433	5.26308
1.58	2.4964	1.25698	3.97492	2.18	4.7524	1.47648	4.66905	2.78	7.7284	1.66733	5.27257
1.59	2.5281	1.26095	3.98748	2.19	4.7961	1.47986	4.67974	2.79	7.7841	1.67033	5.28205
1.60	2.5600	1.26491	4.00000	2.20	4.8400	1.48324	4.69042	2.80	7.8400	1.67332	5.29150
N	N^2	\sqrt{N}	$\sqrt{10N}$	N	N^2	\sqrt{N}	$\sqrt{10N}$	N	N^2	\sqrt{N}	$\sqrt{10N}$

SQUARES AND SQUARE ROOTS

N	N^2	\sqrt{N}	$\sqrt{10N}$	N	N^2	\sqrt{N}	$\sqrt{10N}$	N	N^2	\sqrt{N}	$\sqrt{10N}$
2.80	7.8400	1.67332	5.29150	3.40	11.5600	1.84391	5.83095	4.00	16.0000	2.00000	6.32456
2.81	7.8961	1.67631	5.30094	3.41	11.6281	1.84662	5.83952	4.01	16.0801	2.00250	6.33246
2.82	7.9524	1.67929	5.31037	3.42	11.6964	1.84932	5.84808	4.02	16.1604	2.00499	6.34035
2.83	8.0089	1.68226	5.31977	3.43	11.7649	1.85203	5.85662	4.03	16.2409	2.00749	6.34823
2.84	8.0656	1.68523	5.32917	3.44	11.8336	1.85472	5.86515	4.04	16.3216	2.00998	6.35610
2.85	8.1225	1.68819	5.33854	3.45	11.9025	1.85742	5.87367	4.05	16.4025	2.01246	6.36396
2.86	8.1796	1.69115	5.34790	3.46	11.9716	1.86011	5.88218	4.06	16.4836	2.01494	6.37181
2.87	8.2369	1.69411	5.35724	3.47	12.0409	1.86279	5.89067	4.07	16.5649	2.01742	6.37966
2.88	8.2944	1.69706	5.36656	3.48	12.1104	1.86548	5.89915	4.08	16.6464	2.01990	6.38749
2.89	8.3521	1.70000	5.37587	3.49	12.1801	1.86815	5.90762	4.09	16.7281	2.02237	6.39531
2.90	8.4100	1.70294	5.38516	3.50	12.2500	1.87083	5.91608	4.10	16.8100	2.02485	6.40312
2.91	8.4681	1.70587	5.39444	3.51	12.3201	1.87350	5.92453	4.11	16.8921	2.02731	6.41093
2.92	8.5264	1.70880	5.40370	3.52	12.3904	1.87617	5.93296	4.12	16.9744	2.02978	6.41872
2.93	8.5849	1.71172	5.41295	3.53	12.4609	1.87883	5.94138	4.13	17.0569	2.03224	6.42651
2.94	8.6436	1.71464	5.42218	3.54	12.5316	1.88149	5.94979	4.14	17.1396	2.03470	6.43428
2.95	8.7025	1.71756	5.43139	3.55	12.6025	1.88414	5.95819	4.15	17.2225	2.03715	6.44205
2.96	8.7616	1.72047	5.44059	3.56	12.6736	1.88680	5.96657	4.16	17.3056	2.03961	6.44981
2.97	8.8209	1.72337	5.44977	3.57	12.7449	1.88944	5.97495	4.17	17.3889	2.04206	6.45755
2.98	8.8804	1.72627	5.45894	3.58	12.8164	1.89209	5.98331	4.18	17.4724	2.04450	6.46529
2.99	8.9401	1.72916	5.46809	3.59	12.8881	1.89473	5.99166	4.19	17.5561	2.04695	6.47302
3.00	9.0000	1.73205	5.47723	3.60	12.9600	1.89737	6.00000	4.20	17.6400	2.04939	6.48074
3.01	9.0601	1.73494	5.48635	3.61	13.0321	1.90000	6.00833	4.21	17.7241	2.05183	6.48845
3.02	9.1204	1.73781	5.49545	3.62	13.1044	1.90263	6.01664	4.22	17.8084	2.05426	6.49615
3.03	9.1809	1.74069	5.50454	3.63	13.1769	1.90526	6.02495	4.23	17.8929	2.05670	6.50384
3.04	9.2416	1.74356	5.51362	3.64	13.2496	1.90788	6.03324	4.24	17.9776	2.05913	6.51153
3.05	9.3025	1.74642	5.52268	3.65	13.3225	1.91050	6.04152	4.25	18.0625	2.06155	6.51920
3.06	9.3636	1.74929	5.53173	3.66	13.3956	1.91311	6.04979	4.26	18.1476	2.06398	6.52687
3.07	9.4249	1.75214	5.54076	3.67	13.4689	1.91572	6.05805	4.27	18.2329	2.06640	6.53452
3.08	9.4864	1.75499	5.54977	3.68	13.5424	1.91833	6.06630	4.28	18.3184	2.06882	6.54217
3.09	9.5481	1.75784	5.55878	3.69	13.6161	1.92094	6.07454	4.29	18.4041	2.07123	6.54981
3.10	9.6100	1.76068	5.56776	3.70	13.6900	1.92354	6.08276	4.30	18.4900	2.07364	6.55744
3.11	9.6721	1.76352	5.57674	3.71	13.7641	1.92614	6.09098	4.31	18.5761	2.07605	6.56506
3.12	9.7344	1.76635	5.58570	3.72	13.8384	1.92873	6.09918	4.32	18.6624	2.07846	6.57267
3.13	9.7969	1.76918	5.59464	3.73	13.9129	1.93132	6.10737	4.33	18.7489	2.08087	6.58027
3.14	9.8596	1.77200	5.60357	3.74	13.9876	1.93391	6.11555	4.34	18.8356	2.08327	6.58787
3.15	9.9225	1.77482	5.61249	3.75	14.0625	1.93649	6.12372	4.35	18.9225	2.08567	6.59545
3.16	9.9856	1.77764	5.62139	3.76	14.1376	1.93907	6.13188	4.36	19.0096	2.08806	6.60303
3.17	10.0489	1.78045	5.63028	3.77	14.2129	1.94165	6.14003	4.37	19.0969	2.09045	6.61060
3.18	10.1124	1.78326	5.63915	3.78	14.2884	1.94422	6.14817	4.38	19.1844	2.09284	6.61816
3.19	10.1761	1.78606	5.64801	3.79	14.3641	1.94679	6.15630	4.39	19.2721	2.09523	6.62571
3.20	10.2400	1.78885	5.65685	3.80	14.4400	1.94936	6.16441	4.40	19.3600	2.09762	6.63325
3.21	10.3041	1.79165	5.66569	3.81	14.5161	1.95192	6.17252	4.41	19.4481	2.10000	6.64078
3.22	10.3684	1.79444	5.67450	3.82	14.5924	1.95448	6.18061	4.42	19.5364	2.10238	6.64831
3.23	10.4329	1.79722	5.68331	3.83	14.6689	1.95704	6.18870	4.43	19.6249	2.10476	6.65582
3.24	10.4976	1.80000	5.69210	3.84	14.7456	1.95959	6.19677	4.44	19.7136	2.10713	6.66333
3.25	10.5625	1.80278	5.70088	3.85	14.8225	1.96214	6.20484	4.45	19.8025	2.10950	6.67083
3.26	10.6276	1.80555	5.70964	3.86	14.8996	1.96469	6.21289	4.46	19.8916	2.11187	6.67832
3.27	10.6929	1.80831	5.71839	3.87	14.9769	1.96723	6.22093	4.47	19.9809	2.11424	6.68581
3.28	10.7584	1.81108	5.72713	3.88	15.0544	1.96977	6.22896	4.48	20.0704	2.11660	6.69328
3.29	10.8241	1.81384	5.73585	3.89	15.1321	1.97231	6.23699	4.49	20.1601	2.11896	6.70075
3.30	10.8900	1.81659	5.74456	3.90	15.2100	1.97484	6.24500	4.50	20.2500	2.12132	6.70820
3.31	10.9561	1.81934	5.75326	3.91	15.2881	1.97737	6.25300	4.51	20.3401	2.12368	6.71565
3.32	11.0224	1.82209	5.76194	3.92	15.3664	1.97990	6.26099	4.52	20.4304	2.12603	6.72309
3.33	11.0889	1.82483	5.77062	3.93	15.4449	1.98242	6.26897	4.53	20.5209	2.12838	6.73053
3.34	11.1556	1.82757	5.77927	3.94	15.5236	1.98494	6.27694	4.54	20.6116	2.13073	6.73795
3.35	11.2225	1.83030	5.78792	3.95	15.6025	1.98746	6.28490	4.55	20.7025	2.13307	6.74537
3.36	11.2896	1.83303	5.79655	3.96	15.6816	1.98997	6.29285	4.56	20.7936	2.13542	6.75278
3.37	11.3569	1.83576	5.80517	3.97	15.7609	1.99249	6.30079	4.57	20.8849	2.13776	6.76018
3.38	11.4244	1.83848	5.81378	3.98	15.8404	1.99499	6.30872	4.58	20.9764	2.14009	6.76757
3.39	11.4921	1.84120	5.82237	3.99	15.9201	1.99750	6.31664	4.59	21.0681	2.14243	6.77495
3.40	11.5600	1.84391	5.83095	4.00	16.0000	2.00000	6.32456	4.60	21.1600	2.14476	6.78233
N	N^2	\sqrt{N}	$\sqrt{10N}$	N	N^2	\sqrt{N}	$\sqrt{10N}$	N	N^2	\sqrt{N}	$\sqrt{10N}$

SQUARES AND SQUARE ROOTS

N	N^2	\sqrt{N}	$\sqrt{10N}$	N	N^2	\sqrt{N}	$\sqrt{10N}$	N	N^2	\sqrt{N}	$\sqrt{10N}$
4.60	21.1600	2.14476	6.78233	5.20	27.0400	2.28035	7.21110	5.80	33.6400	2.40832	7.61577
4.61	21.2521	2.14709	6.78970	5.21	27.1441	2.28254	7.21808	5.81	33.7561	2.41039	7.62234
4.62	21.3444	2.14942	6.79706	5.22	27.2484	2.28473	7.22496	5.82	33.8724	2.41247	7.62889
4.63	21.4369	2.15174	6.80441	5.23	27.3529	2.28692	7.23187	5.83	33.9889	2.41454	7.63544
4.64	21.5296	2.15407	6.81175	5.24	27.4576	2.28910	7.23878	5.84	34.1056	2.41661	7.64199
4.65	21.6225	2.15639	6.81909	5.25	27.5625	2.29129	7.24569	5.85	34.2225	2.41868	7.64853
4.66	21.7156	2.15870	6.82642	5.26	27.6676	2.29347	7.25259	5.86	34.3396	2.42074	7.65506
4.67	21.8089	2.16102	6.83374	5.27	27.7729	2.29565	7.25948	5.87	34.4569	2.42281	7.66159
4.68	21.9024	2.16333	6.84105	5.28	27.8784	2.29783	7.26636	5.88	34.5744	2.42487	7.66812
4.69	21.9961	2.16564	6.84836	5.29	27.9841	2.30000	7.27324	5.89	34.6921	2.42693	7.67463
4.70	22.0900	2.16795	6.85565	5.30	28.0900	2.30217	7.28011	5.90	34.8100	2.42899	7.68115
4.71	22.1841	2.17025	6.86294	5.31	28.1961	2.30434	7.28697	5.91	34.9281	2.43105	7.68765
4.72	22.2784	2.17256	6.87023	5.32	28.3024	2.30651	7.29383	5.92	35.0464	2.43311	7.69415
4.73	22.3729	2.17486	6.87750	5.33	28.4089	2.30868	7.30068	5.93	35.1649	2.43516	7.70065
4.74	22.4676	2.17715	6.88477	5.34	28.5156	2.31084	7.30753	5.94	35.2836	2.43721	7.70714
4.75	22.5625	2.17945	6.89202	5.35	28.6225	2.31301	7.31437	5.95	35.4025	2.43926	7.71362
4.76	22.6576	2.18174	6.89928	5.36	28.7296	2.31517	7.32120	5.96	35.5216	2.44131	7.72010
4.77	22.7529	2.18403	6.90652	5.37	28.8369	2.31733	7.32803	5.97	35.6409	2.44336	7.72658
4.78	22.8484	2.18632	6.91375	5.38	28.9444	2.31948	7.33485	5.98	35.7604	2.44540	7.73305
4.79	22.9441	2.18861	6.92098	5.39	29.0521	2.32164	7.34166	5.99	35.8801	2.44745	7.73951
4.80	23.0400	2.19089	6.92820	5.40	29.1600	2.32379	7.34847	6.00	36.0000	2.44949	7.74597
4.81	23.1361	2.19317	6.93542	5.41	29.2681	2.32594	7.35527	6.01	36.1201	2.45153	7.75242
4.82	23.2324	2.19545	6.94262	5.42	29.3764	2.32809	7.36206	6.02	36.2404	2.45357	7.75887
4.83	23.3289	2.19773	6.94982	5.43	29.4849	2.33024	7.36885	6.03	36.3609	2.45561	7.76531
4.84	23.4256	2.20000	6.95701	5.44	29.5936	2.33238	7.37564	6.04	36.4816	2.45764	7.77174
4.85	23.5225	2.20227	6.96419	5.45	29.7025	2.33452	7.38241	6.05	36.6025	2.45967	7.77817
4.86	23.6196	2.20454	6.97137	5.46	29.8116	2.33666	7.38918	6.06	36.7236	2.46171	7.78460
4.87	23.7169	2.20681	6.97854	5.47	29.9209	2.33880	7.39594	6.07	36.8449	2.46374	7.79102
4.88	23.8144	2.20907	6.98570	5.48	30.0304	2.34094	7.40270	6.08	36.9664	2.46577	7.79744
4.89	23.9121	2.21133	6.99285	5.49	30.1401	2.34307	7.40945	6.09	37.0881	2.46779	7.80385
4.90	24.0100	2.21359	7.00000	5.50	30.2500	2.34521	7.41620	6.10	37.2100	2.46982	7.81025
4.91	24.1081	2.21585	7.00714	5.51	30.3601	2.34734	7.42294	6.11	37.3321	2.47184	7.81665
4.92	24.2064	2.21811	7.01427	5.52	30.4704	2.34947	7.42967	6.12	37.4544	2.47386	7.82304
4.93	24.3049	2.22036	7.02140	5.53	30.5809	2.35160	7.43640	6.13	37.5769	2.47588	7.82943
4.94	24.4036	2.22261	7.02851	5.54	30.6916	2.35372	7.44312	6.14	37.6996	2.47790	7.83582
4.95	24.5025	2.22486	7.03562	5.55	30.8025	2.35584	7.44983	6.15	37.8225	2.47992	7.84219
4.96	24.6016	2.22711	7.04273	5.56	30.9136	2.35797	7.45654	6.16	37.9456	2.48193	7.84857
4.97	24.7009	2.22935	7.04982	5.57	31.0249	2.36008	7.46324	6.17	38.0689	2.48395	7.85493
4.98	24.8004	2.23159	7.05691	5.58	31.1364	2.36220	7.46994	6.18	38.1924	2.48596	7.86130
4.99	24.9001	2.23383	7.06399	5.59	31.2481	2.36432	7.47663	6.19	38.3161	2.48797	7.86766
5.00	25.0000	2.23607	7.07107	5.60	31.3600	2.36643	7.48331	6.20	38.4400	2.48998	7.87401
5.01	25.1001	2.23830	7.07814	5.61	31.4721	2.36854	7.48999	6.21	38.5641	2.49199	7.88036
5.02	25.2004	2.24054	7.08520	5.62	31.5844	2.37065	7.49667	6.22	38.6884	2.49399	7.88670
5.03	25.3009	2.24277	7.09225	5.63	31.6969	2.37276	7.50333	6.23	38.8129	2.49600	7.89303
5.04	25.4016	2.24499	7.09930	5.64	31.8096	2.37487	7.50999	6.24	38.9376	2.49800	7.89937
5.05	25.5025	2.24722	7.10634	5.65	31.9225	2.37697	7.51665	6.25	39.0625	2.50000	7.90569
5.06	25.6036	2.24944	7.11337	5.66	32.0356	2.37908	7.52330	6.26	39.1876	2.50200	7.91202
5.07	25.7049	2.25167	7.12039	5.67	32.1489	2.38118	7.52994	6.27	39.3129	2.50400	7.91833
5.08	25.8064	2.25389	7.12741	5.68	32.2624	2.38328	7.53658	6.28	39.4384	2.50599	7.92465
5.09	25.9081	2.25610	7.13442	5.69	32.3761	2.38537	7.54321	6.29	39.5641	2.50799	7.93095
5.10	26.0100	2.25832	7.14143	5.70	32.4900	2.38747	7.54983	6.30	39.6900	2.50998	7.93725
5.11	26.1121	2.26053	7.14843	5.71	32.6041	2.38956	7.55645	6.31	39.8161	2.51197	7.94355
5.12	26.2144	2.26274	7.15542	5.72	32.7184	2.39165	7.56307	6.32	39.9424	2.51396	7.94984
5.13	26.3169	2.26495	7.16240	5.73	32.8329	2.39374	7.56968	6.33	40.0689	2.51595	7.95613
5.14	26.4196	2.26716	7.16938	5.74	32.9476	2.39583	7.57628	6.34	40.1956	2.51794	7.96241
5.15	26.5225	2.26936	7.17635	5.75	33.0625	2.39792	7.58288	6.35	40.3225	2.51992	7.96869
5.16	26.6256	2.27156	7.18331	5.76	33.1776	2.40000	7.58947	6.36	40.4496	2.52190	7.97496
5.17	26.7289	2.27376	7.19027	5.77	33.2929	2.40208	7.59605	6.37	40.5769	2.52389	7.98123
5.18	26.8324	2.27596	7.19722	5.78	33.4084	2.40416	7.60263	6.38	40.7044	2.52587	7.98749
5.19	26.9361	2.27816	7.20417	5.79	33.5241	2.40624	7.60920	6.39	40.8321	2.52784	7.99375
5.20	27.0400	2.28035	7.21110	5.80	33.6400	2.40832	7.61577	6.40	40.9600	2.52982	8.00000
N	N^2	\sqrt{N}	$\sqrt{10N}$	N	N^2	\sqrt{N}	$\sqrt{10N}$	N	N^2	\sqrt{N}	$\sqrt{10N}$

SQUARES AND SQUARE ROOTS

N	N^2	\sqrt{N}	$\sqrt{10N}$	N	N^2	\sqrt{N}	$\sqrt{10N}$	N	N^2	\sqrt{N}	$\sqrt{10N}$
6.40	40.9600	2.52982	8.00000	7.00	49.0000	2.64575	8.36660	7.60	57.7600	2.75681	8.71780
6.41	41.0881	2.53180	8.00625	7.01	49.1401	2.64764	8.37257	7.61	57.9121	2.75862	8.72353
6.42	41.2164	2.53377	8.01249	7.02	49.2804	2.64953	8.37854	7.62	58.0644	2.76043	8.72926
6.43	41.3449	2.53574	8.01873	7.03	49.4209	2.65141	8.38451	7.63	58.2169	2.76225	8.73499
6.44	41.4736	2.53772	8.02496	7.04	49.5616	2.65330	8.39047	7.64	58.3696	2.76405	8.74071
6.45	41.6025	2.53969	8.03119	7.05	49.7025	2.65518	8.39643	7.65	58.5225	2.76586	8.74643
6.46	41.7316	2.54165	8.03741	7.06	49.8436	2.65707	8.40238	7.66	58.6756	2.76767	8.75214
6.47	41.8609	2.54362	8.04363	7.07	49.9849	2.65895	8.40833	7.67	58.8289	2.76948	8.75785
6.48	41.9904	2.54558	8.04984	7.08	50.1264	2.66083	8.41427	7.68	58.9824	2.77128	8.76356
6.49	42.1201	2.54755	8.05605	7.09	50.2681	2.66271	8.42021	7.69	59.1361	2.77308	8.76926
6.50	42.2500	2.54951	8.06226	7.10	50.4100	2.66458	8.42615	7.70	59.2900	2.77489	8.77496
6.51	42.3801	2.55147	8.06846	7.11	50.5521	2.66646	8.43208	7.71	59.4441	2.77669	8.78066
6.52	42.5104	2.55343	8.07465	7.12	50.6944	2.66833	8.43801	7.72	59.5984	2.77849	8.78635
6.53	42.6409	2.55539	8.08084	7.13	50.8369	2.67021	8.44393	7.73	59.7529	2.78029	8.79204
6.54	42.7716	2.55734	8.08703	7.14	50.9796	2.67208	8.44985	7.74	59.9076	2.78209	8.79773
6.55	42.9025	2.55930	8.09321	7.15	51.1225	2.67395	8.45577	7.75	60.0625	2.78388	8.80341
6.56	43.0336	2.56125	8.09938	7.16	51.2656	2.67582	8.46168	7.76	60.2176	2.78568	8.80909
6.57	43.1649	2.56320	8.10555	7.17	51.4089	2.67769	8.46759	7.77	60.3729	2.78747	8.81476
6.58	43.2964	2.56515	8.11172	7.18	51.5524	2.67955	8.47349	7.78	60.5284	2.78927	8.82043
6.59	43.4281	2.56710	8.11788	7.19	51.6961	2.68142	8.47939	7.79	60.6841	2.79106	8.82610
6.60	43.5600	2.56905	8.12404	7.20	51.8400	2.68328	8.48528	7.80	60.8400	2.79285	8.83176
6.61	43.6921	2.57099	8.13019	7.21	51.9841	2.68514	8.49117	7.81	60.9961	2.79464	8.83742
6.62	43.8244	2.57294	8.13634	7.22	52.1284	2.68701	8.49706	7.82	61.1524	2.79643	8.84308
6.63	43.9569	2.57488	8.14248	7.23	52.2729	2.68887	8.50294	7.83	61.3089	2.79821	8.84873
6.64	44.0896	2.57682	8.14862	7.24	52.4176	2.69072	8.50882	7.84	61.4656	2.80000	8.85438
6.65	44.2225	2.57876	8.15475	7.25	52.5625	2.69258	8.51469	7.85	61.6225	2.80179	8.86002
6.66	44.3556	2.58070	8.16088	7.26	52.7076	2.69444	8.52056	7.86	61.7796	2.80357	8.86566
6.67	44.4889	2.58263	8.16701	7.27	52.8529	2.69629	8.52643	7.87	61.9369	2.80535	8.87130
6.68	44.6224	2.58457	8.17313	7.28	52.9984	2.69815	8.53229	7.88	62.0944	2.80713	8.87694
6.69	44.7561	2.58650	8.17924	7.29	53.1441	2.70000	8.53815	7.89	62.2521	2.80891	8.88257
6.70	44.8900	2.58844	8.18535	7.30	53.2900	2.70185	8.54400	7.90	62.4100	2.81069	8.88819
6.71	45.0241	2.59037	8.19146	7.31	53.4361	2.70370	8.54985	7.91	62.5681	2.81247	8.89382
6.72	45.1584	2.59230	8.19756	7.32	53.5824	2.70555	8.55570	7.92	62.7264	2.81425	8.89944
6.73	45.2929	2.59422	8.20366	7.33	53.7289	2.70740	8.56154	7.93	62.8849	2.81603	8.90505
6.74	45.4276	2.59615	8.20975	7.34	53.8756	2.70924	8.56738	7.94	63.0436	2.81780	8.91067
6.75	45.5625	2.59808	8.21584	7.35	54.0225	2.71109	8.57321	7.95	63.2025	2.81957	8.91628
6.76	45.6976	2.60000	8.22192	7.36	54.1696	2.71293	8.57904	7.96	63.3616	2.82135	8.92188
6.77	45.8329	2.60192	8.22800	7.37	54.3169	2.71477	8.58487	7.97	63.5209	2.82312	8.92749
6.78	45.9684	2.60384	8.23408	7.38	54.4644	2.71662	8.59069	7.98	63.6804	2.82489	8.93308
6.79	46.1041	2.60576	8.24015	7.39	54.6121	2.71846	8.59651	7.99	63.8401	2.82666	8.93868
6.80	46.2400	2.60768	8.24621	7.40	54.7600	2.72029	8.60233	8.00	64.0000	2.82843	8.94427
6.81	46.3761	2.60960	8.25227	7.41	54.9081	2.72213	8.60814	8.01	64.1601	2.83019	8.94986
6.82	46.5124	2.61151	8.25833	7.42	55.0564	2.72397	8.61394	8.02	64.3204	2.83196	8.95545
6.83	46.6489	2.61343	8.26438	7.43	55.2049	2.72580	8.61974	8.03	64.4809	2.83373	8.96103
6.84	46.7856	2.61534	8.27043	7.44	55.3536	2.72764	8.62554	8.04	64.6416	2.83549	8.96660
6.85	46.9225	2.61725	8.27647	7.45	55.5025	2.72947	8.63134	8.05	64.8025	2.83725	8.97218
6.86	47.0596	2.61916	8.28251	7.46	55.6516	2.73130	8.63713	8.06	64.9636	2.83901	8.97775
6.87	47.1969	2.62107	8.28855	7.47	55.8009	2.73313	8.64292	8.07	65.1249	2.84077	8.98332
6.88	47.3344	2.62298	8.29458	7.48	55.9504	2.73496	8.64870	8.08	65.2864	2.84253	8.98888
6.89	47.4721	2.62488	8.30060	7.49	56.1001	2.73679	8.65448	8.09	65.4481	2.84429	8.99444
6.90	47.6100	2.62679	8.30662	7.50	56.2500	2.73861	8.66025	8.10	65.6100	2.84605	9.00000
6.91	47.7481	2.62869	8.31264	7.51	56.4001	2.74044	8.66603	8.11	65.7721	2.84781	9.00555
6.92	47.8864	2.63059	8.31865	7.52	56.5504	2.74226	8.67179	8.12	65.9344	2.84956	9.01110
6.93	48.0249	2.63249	8.32466	7.53	56.7009	2.74408	8.67756	8.13	66.0969	2.85132	9.01665
6.94	48.1636	2.63439	8.33067	7.54	56.8516	2.74591	8.68332	8.14	66.2596	2.85307	9.02219
6.95	48.3025	2.63629	8.33667	7.55	57.0025	2.74773	8.68907	8.15	66.4225	2.85482	9.02774
6.96	48.4416	2.63818	8.34266	7.56	57.1536	2.74955	8.69483	8.16	66.5856	2.85657	9.03327
6.97	48.5809	2.64008	8.34865	7.57	57.3049	2.75136	8.70057	8.17	66.7489	2.85832	9.03881
6.98	48.7204	2.64197	8.35464	7.58	57.4564	2.75318	8.70632	8.18	66.9124	2.86007	9.04434
6.99	48.8601	2.64386	8.36062	7.59	57.6081	2.75500	8.71206	8.19	67.0761	2.86182	9.04986
7.00	49.0000	2.64575	8.36660	7.60	57.7600	2.75681	8.71780	8.20	67.2400	2.86356	9.05539
N	N^2	\sqrt{N}	$\sqrt{10N}$	N	N^2	\sqrt{N}	$\sqrt{10N}$	N	N^2	\sqrt{N}	$\sqrt{10N}$

SQUARES AND SQUARE ROOTS

N	N^2	\sqrt{N}	$\sqrt{10N}$	N	N^2	\sqrt{N}	$\sqrt{10N}$	N	N^2	\sqrt{N}	$\sqrt{10N}$
8.20	67.2400	2.86356	9.05539	8.80	77.4400	2.96648	9.38083	9.40	88.3600	3.06594	9.69536
8.21	67.4041	2.86531	9.06091	8.81	77.6161	2.96816	9.38616	9.41	88.5481	3.06757	9.70052
8.22	67.5684	2.86705	9.06642	8.82	77.7924	2.96985	9.39149	9.42	88.7364	3.06920	9.70567
8.23	67.7329	2.86880	9.07193	8.83	77.9689	2.97153	9.39681	9.43	88.9249	3.07083	9.71082
8.24	67.8976	2.87054	9.07744	8.84	78.1456	2.97321	9.40213	9.44	89.1136	3.07246	9.71597
8.25	68.0625	2.87228	9.08295	8.85	78.3225	2.97489	9.40744	9.45	89.3025	3.07409	9.72111
8.26	68.2276	2.87402	9.08845	8.86	78.4996	2.97658	9.41276	9.46	89.4916	3.07571	9.72625
8.27	68.3929	2.87576	9.09395	8.87	78.6769	2.97825	9.41807	9.47	89.6809	3.07734	9.73139
8.28	68.5584	2.87750	9.09945	8.88	78.8544	2.97993	9.42338	9.48	89.8704	3.07896	9.73653
8.29	68.7241	2.87924	9.10494	8.89	79.0321	2.98161	9.42868	9.49	90.0601	3.08058	9.74166
8.30	68.8900	2.88097	9.11043	8.90	79.2100	2.98329	9.43398	9.50	90.2500	3.08221	9.74679
8.31	69.0561	2.88271	9.11592	8.91	79.3881	2.98496	9.43928	9.51	90.4401	3.08383	9.75192
8.32	69.2224	2.88444	9.12140	8.92	79.5664	2.98664	9.44458	9.52	90.6304	3.08545	9.75705
8.33	69.3889	2.88617	9.12688	8.93	79.7449	2.98831	9.44987	9.53	90.8209	3.08707	9.76217
8.34	69.5556	2.88791	9.13236	8.94	79.9236	2.98998	9.45516	9.54	91.0116	3.08869	9.76729
8.35	69.7225	2.88964	9.13783	8.95	80.1025	2.99166	9.46044	9.55	91.2025	3.09031	9.77241
8.36	69.8896	2.89137	9.14330	8.96	80.2816	2.99333	9.46573	9.56	91.3936	3.09192	9.77753
8.37	70.0569	2.89310	9.14877	8.97	80.4609	2.99500	9.47101	9.57	91.5849	3.09354	9.78266
8.38	70.2244	2.89482	9.15423	8.98	80.6404	2.99666	9.47629	9.58	91.7764	3.09516	9.78775
8.39	70.3921	2.89655	9.15969	8.99	80.8201	2.99833	9.48156	9.59	91.9681	3.09677	9.79285
8.40	70.5600	2.89828	9.16515	9.00	81.0000	3.00000	9.48683	9.60	92.1600	3.09839	9.79796
8.41	70.7281	2.90000	9.17061	9.01	81.1801	3.00167	9.49210	9.61	92.3521	3.10000	9.80306
8.42	70.8964	2.90172	9.17606	9.02	81.3604	3.00333	9.49737	9.62	92.5444	3.10161	9.80816
8.43	71.0649	2.90345	9.18150	9.03	81.5409	3.00500	9.50263	9.63	92.7369	3.10322	9.81326
8.44	71.2336	2.90517	9.18695	9.04	81.7216	3.00666	9.50789	9.64	92.9296	3.10483	9.81835
8.45	71.4025	2.90689	9.19239	9.05	81.9025	3.00832	9.51315	9.65	93.1225	3.10644	9.82344
8.46	71.5716	2.90861	9.19783	9.06	82.0836	3.00998	9.51840	9.66	93.3156	3.10805	9.82853
8.47	71.7409	2.91033	9.20326	9.07	82.2649	3.01164	9.52365	9.67	93.5089	3.10966	9.83362
8.48	71.9104	2.91204	9.20869	9.08	82.4464	3.01330	9.52890	9.68	93.7024	3.11127	9.83870
8.49	72.0801	2.91376	9.21412	9.09	82.6281	3.01496	9.53415	9.69	93.8961	3.11288	9.84378
8.50	72.2500	2.91548	9.21954	9.10	82.8100	3.01662	9.53939	9.70	94.0900	3.11448	9.84886
8.51	72.4201	2.91719	9.22497	9.11	82.9921	3.01828	9.54463	9.71	94.2841	3.11609	9.85393
8.52	72.5904	2.91890	9.23033	9.12	83.1744	3.01993	9.54987	9.72	94.4784	3.11769	9.85901
8.53	72.7609	2.92062	9.23580	9.13	83.3569	3.02159	9.55510	9.73	94.6729	3.11929	9.86408
8.54	72.9316	2.92233	9.24121	9.14	83.5396	3.02324	9.56033	9.74	94.8676	3.12090	9.86914
8.55	73.1025	2.92404	9.24662	9.15	83.7225	3.02490	9.56556	9.75	95.0625	3.12250	9.87421
8.56	73.2736	2.92575	9.25203	9.16	83.9056	3.02655	9.57079	9.76	95.2576	3.12410	9.87927
8.57	73.4449	2.92746	9.25743	9.17	84.0889	3.02820	9.57601	9.77	95.4529	3.12570	9.88433
8.58	73.6164	2.92916	9.26283	9.18	84.2724	3.02985	9.58123	9.78	95.6484	3.12730	9.88939
8.59	73.7881	2.93087	9.26823	9.19	84.4561	3.03150	9.58645	9.79	95.8441	3.12890	9.89444
8.60	73.9600	2.93258	9.27362	9.20	84.6400	3.03315	9.59166	9.80	96.0400	3.13050	9.89949
8.61	74.1321	2.93428	9.27901	9.21	84.8241	3.03480	9.59687	9.81	96.2361	3.13209	9.90454
8.62	74.3044	2.93598	9.28440	9.22	85.0084	3.03645	9.60208	9.82	96.4324	3.13369	9.90959
8.63	74.4769	2.93769	9.28978	9.23	85.1929	3.03809	9.60729	9.83	96.6289	3.13528	9.91464
8.64	74.6496	2.93939	9.29516	9.24	85.3776	3.03974	9.61249	9.84	96.8256	3.13688	9.91968
8.65	74.8225	2.94109	9.30054	9.25	85.5625	3.04138	9.61769	9.85	97.0225	3.13847	9.92472
8.66	74.9956	2.94279	9.30591	9.26	85.7476	3.04302	9.62289	9.86	97.2196	3.14006	9.92975
8.67	75.1689	2.94449	9.31128	9.27	85.9329	3.04467	9.62808	9.87	97.4169	3.14166	9.93479
8.68	75.3424	2.94618	9.31665	9.28	86.1184	3.04631	9.63328	9.88	97.6144	3.14325	9.93982
8.69	75.5161	2.94788	9.32202	9.29	86.3041	3.04795	9.63846	9.89	97.8121	3.14484	9.94485
8.70	75.6900	2.94958	9.32738	9.30	86.4900	3.04959	9.64365	9.90	98.0100	3.14643	9.94987
8.71	75.8641	2.95127	9.33274	9.31	86.6761	3.05123	9.64883	9.91	98.2081	3.14802	9.95490
8.72	76.0384	2.95296	9.33809	9.32	86.8624	3.05287	9.65401	9.92	98.4064	3.14960	9.95992
8.73	76.2129	2.95466	9.34345	9.33	87.0489	3.05450	9.65919	9.93	98.6049	3.15119	9.96494
8.74	76.3876	2.95635	9.34880	9.34	87.2356	3.05614	9.66437	9.94	98.8036	3.15278	9.96995
8.75	76.5625	2.95804	9.35414	9.35	87.4225	3.05778	9.66954	9.95	99.0025	3.15436	9.97497
8.76	76.7376	2.95973	9.35949	9.36	87.6096	3.05941	9.67471	9.96	99.2016	3.15595	9.97998
8.77	76.9129	2.96142	9.36483	9.37	87.7969	3.06105	9.67988	9.97	99.4009	3.15753	9.98499
8.78	77.0884	2.96311	9.37017	9.38	87.9844	3.06268	9.68504	9.98	99.6004	3.15911	9.98999
8.79	77.2641	2.96479	9.37550	9.39	88.1721	3.06431	9.69020	9.99	99.8001	3.16070	9.99500
8.80	77.4400	2.96648	9.38083	9.40	88.3600	3.06594	9.69536	10.00	100.000	3.16228	10.0000

NATURAL (NAPIERIAN) LOGARITHMS

The natural logarithm of a number is the index of the power to which the base e (2.7182818) must be raised in order to equal the number.

Example: $\log_e 4.12 = \ln 4.12 = 1.4159$.

The table gives the natural logarithms of numbers from 1.00 to 9.99 directly, and permits finding logarithms of numbers outside that range by the addition or subtraction of the natural logarithms of powers of 10.

Example: $\ln 879. = \ln 8.79 + \ln 10^2 = 1.9155 + 4.6052 = 6.5207$

$\ln 0.0879 = \ln 8.79 - \ln 10^2 = 1.9155 - 4.6052 = -2.6897$

Natural Logarithms of 10^k

$\ln 10^4 = 2.302585$	$\ln 10^4 = 9.210340$	$\ln 10^7 = 18.118096$
$\ln 10^5 = 4.605170$	$\ln 10^6 = 11.512925$	$\ln 10^8 = 18.420681$
$\ln 10^3 = 6.907755$	$\ln 10^8 = 18.815511$	$\ln 10^9 = 20.723286$

To obtain the common logarithm, the natural logarithm is multiplied by $\log_{10} e$, which is 0.434294, or $\log_{10} N = 0.434294 \ln N$.

N	0	1	2	3	4	5	6	7	8	9
1.0	0.0000	0.0100	0.0198	0.0296	0.0392	0.0488	0.0583	0.0677	0.0770	0.0862
1.1	0.0953	0.1044	0.1133	0.1222	0.1310	0.1398	0.1484	0.1570	0.1655	0.1740
1.2	0.1823	0.1906	0.1989	0.2070	0.2151	0.2231	0.2311	0.2390	0.2469	0.2546
1.3	0.2624	0.2700	0.2776	0.2852	0.2927	0.3001	0.3075	0.3148	0.3221	0.3293
1.4	0.3365	0.3436	0.3507	0.3577	0.3646	0.3716	0.3784	0.3853	0.3920	0.3988
1.5	0.4055	0.4121	0.4187	0.4253	0.4313	0.4383	0.4447	0.4511	0.4574	0.4637
1.6	0.4700	0.4762	0.4824	0.4886	0.4947	0.5008	0.5068	0.5128	0.5188	0.5247
1.7	0.5306	0.5365	0.5423	0.5481	0.5539	0.5596	0.5653	0.5710	0.5766	0.5822
1.8	0.5878	0.5933	0.5988	0.6043	0.6098	0.6152	0.6206	0.6259	0.6313	0.6366
1.9	0.6419	0.6471	0.6523	0.6575	0.6627	0.6678	0.6729	0.6780	0.6831	0.6881
2.0	0.6931	0.6981	0.7031	0.7080	0.7129	0.7178	0.7227	0.7275	0.7324	0.7372
2.1	0.7419	0.7467	0.7514	0.7561	0.7608	0.7655	0.7701	0.7747	0.7793	0.7839
2.2	0.7885	0.7930	0.7975	0.8020	0.8065	0.8109	0.8154	0.8198	0.8242	0.8286
2.3	0.8329	0.8372	0.8416	0.8459	0.8502	0.8544	0.8587	0.8629	0.8671	0.8713
2.4	0.8755	0.8796	0.8838	0.8879	0.8920	0.8961	0.9002	0.9042	0.9083	0.9123
2.5	0.9163	0.9203	0.9243	0.9282	0.9322	0.9361	0.9400	0.9439	0.9478	0.9517
2.6	0.9555	0.9594	0.9632	0.9670	0.9708	0.9746	0.9783	0.9821	0.9858	0.9895
2.7	0.9933	0.9969	1.0006	1.0043	1.0080	1.0116	1.0152	1.0188	1.0225	1.0260
2.8	1.0296	1.0332	1.0367	1.0403	1.0438	1.0473	1.0508	1.0543	1.0578	1.0613
2.9	1.0647	1.0682	1.0716	1.0750	1.0784	1.0818	1.0852	1.0886	1.0919	1.0953
3.0	1.0986	1.1019	1.1053	1.1086	1.1119	1.1151	1.1184	1.1217	1.1249	1.1282
3.1	1.1314	1.1346	1.1378	1.1410	1.1442	1.1474	1.1506	1.1537	1.1569	1.1600
3.2	1.1632	1.1663	1.1694	1.1725	1.1756	1.1787	1.1817	1.1848	1.1878	1.1909
3.3	1.1939	1.1969	1.2000	1.2030	1.2060	1.2090	1.2119	1.2149	1.2179	1.2208
3.4	1.2238	1.2267	1.2296	1.2326	1.2355	1.2384	1.2413	1.2442	1.2470	1.2499
3.5	1.2528	1.2556	1.2585	1.2613	1.2641	1.2669	1.2698	1.2726	1.2754	1.2782
3.6	1.2809	1.2837	1.2865	1.2892	1.2920	1.2947	1.2975	1.3002	1.3029	1.3056
3.7	1.3083	1.3110	1.3137	1.3164	1.3191	1.3218	1.3244	1.3271	1.3297	1.3324
3.8	1.3350	1.3376	1.3403	1.3429	1.3455	1.3481	1.3507	1.3533	1.3558	1.3584
3.9	1.3610	1.3635	1.3661	1.3686	1.3712	1.3737	1.3762	1.3788	1.3813	1.3838
4.0	1.3868	1.3888	1.3913	1.3938	1.3962	1.3987	1.4012	1.4036	1.4061	1.4085
4.1	1.4110	1.4134	1.4159	1.4183	1.4207	1.4231	1.4255	1.4279	1.4303	1.4327
4.2	1.4351	1.4375	1.4398	1.4422	1.4446	1.4469	1.4493	1.4516	1.4540	1.4563
4.3	1.4586	1.4609	1.4633	1.4656	1.4679	1.4702	1.4725	1.4748	1.4770	1.4793
4.4	1.4816	1.4839	1.4861	1.4884	1.4907	1.4929	1.4951	1.4974	1.4996	1.5019
4.5	1.5041	1.5063	1.5085	1.5107	1.5129	1.5151	1.5173	1.5195	1.5217	1.5239
4.6	1.5261	1.5282	1.5304	1.5326	1.5347	1.5369	1.5390	1.5412	1.5433	1.5454
4.7	1.5476	1.5497	1.5518	1.5539	1.5560	1.5581	1.5602	1.5623	1.5644	1.5665
4.8	1.5686	1.5707	1.5728	1.5748	1.5769	1.5790	1.5810	1.5831	1.5851	1.5872
4.9	1.5892	1.5913	1.5933	1.5953	1.5974	1.5994	1.6014	1.6034	1.6054	1.6074

NATURAL LOGARITHMS (continued)

N	0	1	2	3	4	5	6	7	8	9
5.0	1.6094	1.6114	1.6134	1.6154	1.6174	1.6194	1.6214	1.6233	1.6253	1.6273
5.1	1.6292	1.6312	1.6332	1.6351	1.6371	1.6390	1.6409	1.6429	1.6448	1.6467
5.2	1.6487	1.6506	1.6525	1.6544	1.6563	1.6582	1.6601	1.6620	1.6639	1.6658
5.3	1.6677	1.6696	1.6715	1.6734	1.6752	1.6771	1.6790	1.6808	1.6827	1.6845
5.4	1.6864	1.6882	1.6901	1.6919	1.6938	1.6956	1.6974	1.6993	1.7011	1.7029
5.5	1.7047	1.7066	1.7084	1.7102	1.7120	1.7138	1.7156	1.7174	1.7192	1.7210
5.6	1.7228	1.7246	1.7263	1.7281	1.7299	1.7317	1.7334	1.7352	1.7370	1.7387
5.7	1.7405	1.7422	1.7440	1.7457	1.7475	1.7492	1.7509	1.7527	1.7544	1.7561
5.8	1.7579	1.7596	1.7613	1.7630	1.7647	1.7664	1.7681	1.7699	1.7716	1.7733
5.9	1.7750	1.7766	1.7783	1.7800	1.7817	1.7834	1.7851	1.7867	1.7884	1.7901
6.0	1.7918	1.7934	1.7951	1.7967	1.7984	1.8001	1.8017	1.8034	1.8050	1.8066
6.1	1.8083	1.8099	1.8116	1.8132	1.8148	1.8165	1.8181	1.8197	1.8213	1.8229
6.2	1.8245	1.8262	1.8278	1.8294	1.8310	1.8326	1.8342	1.8358	1.8374	1.8390
6.3	1.8405	1.8421	1.8437	1.8453	1.8469	1.8485	1.8500	1.8516	1.8532	1.8547
6.4	1.8563	1.8579	1.8594	1.8610	1.8625	1.8641	1.8656	1.8672	1.8687	1.8703
6.5	1.8718	1.8733	1.8749	1.8764	1.8779	1.8795	1.8810	1.8825	1.8840	1.8856
6.6	1.8871	1.8886	1.8901	1.8916	1.8931	1.8946	1.8961	1.8976	1.8991	1.9006
6.7	1.9021	1.9036	1.9051	1.9066	1.9081	1.9095	1.9110	1.9125	1.9140	1.9155
6.8	1.9169	1.9184	1.9199	1.9213	1.9228	1.9242	1.9257	1.9272	1.9286	1.9301
6.9	1.9315	1.9330	1.9344	1.9359	1.9373	1.9387	1.9402	1.9416	1.9430	1.9445
7.0	1.9459	1.9473	1.9488	1.9502	1.9516	1.9530	1.9544	1.9559	1.9573	1.9587
7.1	1.9601	1.9615	1.9629	1.9643	1.9657	1.9671	1.9685	1.9699	1.9713	1.9727
7.2	1.9741	1.9755	1.9769	1.9782	1.9796	1.9810	1.9824	1.9838	1.9851	1.9865
7.3	1.9879	1.9892	1.9906	1.9920	1.9933	1.9947	1.9961	1.9974	1.9988	2.0001
7.4	2.0015	2.0028	2.0042	2.0055	2.0069	2.0082	2.0096	2.0109	2.0122	2.0136
7.5	2.0149	2.0162	2.0176	2.0189	2.0202	2.0215	2.0229	2.0242	2.0255	2.0268
7.6	2.0281	2.0295	2.0308	2.0321	2.0334	2.0347	2.0360	2.0373	2.0386	2.0399
7.7	2.0412	2.0425	2.0438	2.0451	2.0464	2.0477	2.0490	2.0503	2.0516	2.0528
7.8	2.0541	2.0554	2.0567	2.0580	2.0592	2.0605	2.0618	2.0631	2.0643	2.0656
7.9	2.0669	2.0681	2.0694	2.0707	2.0719	2.0732	2.0744	2.0757	2.0769	2.0782
8.0	2.0794	2.0807	2.0819	2.0832	2.0844	2.0857	2.0869	2.0882	2.0894	2.0906
8.1	2.0919	2.0931	2.0943	2.0956	2.0968	2.0980	2.0992	2.1005	2.1017	2.1029
8.2	2.1041	2.1054	2.1066	2.1078	2.1090	2.1102	2.1114	2.1126	2.1138	2.1150
8.3	2.1163	2.1175	2.1187	2.1199	2.1211	2.1223	2.1235	2.1247	2.1258	2.1270
8.4	2.1282	2.1294	2.1306	2.1318	2.1330	2.1342	2.1353	2.1365	2.1377	2.1389
8.5	2.1401	2.1412	2.1424	2.1436	2.1448	2.1459	2.1471	2.1483	2.1494	2.1506
8.6	2.1518	2.1529	2.1541	2.1552	2.1564	2.1576	2.1587	2.1599	2.1610	2.1622
8.7	2.1633	2.1645	2.1656	2.1668	2.1679	2.1691	2.1702	2.1713	2.1725	2.1736
8.8	2.1748	2.1759	2.1770	2.1782	2.1793	2.1804	2.1815	2.1827	2.1838	2.1849
8.9	2.1861	2.1872	2.1883	2.1894	2.1905	2.1917	2.1928	2.1939	2.1950	2.1961
9.0	2.1972	2.1983	2.1994	2.2006	2.2017	2.2028	2.2039	2.2050	2.2061	2.2072
9.1	2.2083	2.2094	2.2105	2.2116	2.2127	2.2138	2.2148	2.2159	2.2170	2.2181
9.2	2.2192	2.2203	2.2214	2.2225	2.2235	2.2246	2.2257	2.2268	2.2279	2.2289
9.3	2.2300	2.2311	2.2322	2.2332	2.2343	2.2354	2.2364	2.2375	2.2386	2.2396
9.4	2.2407	2.2418	2.2428	2.2439	2.2450	2.2460	2.2471	2.2481	2.2492	2.2502
9.5	2.2513	2.2523	2.2534	2.2544	2.2555	2.2565	2.2576	2.2586	2.2597	2.2607
9.6	2.2618	2.2628	2.2638	2.2649	2.2659	2.2670	2.2680	2.2690	2.2701	2.2711
9.7	2.2721	2.2732	2.2742	2.2752	2.2762	2.2773	2.2783	2.2793	2.2803	2.2814
9.8	2.2824	2.2834	2.2844	2.2854	2.2865	2.2875	2.2885	2.2895	2.2905	2.2915
9.9	2.2925	2.2935	2.2946	2.2956	2.2966	2.2976	2.2986	2.2996	2.3006	2.3016

LOGARITHMS TO BASE 10

N	0	1	2	3	4	5	6	7	8	9	1 2 3	4 5 6	7 8 9
10	0000	0043	0086	0128	0170	0212	0253	0294	0334	0374	4 8 12	17 21 25	29 33 37
11	0414	0453	0492	0531	0569	0607	0645	0682	0719	0755	4 8 11	15 19 23	26 30 34
12	0792	0828	0864	0899	0934	0969	1004	1038	1072	1106	3 7 10	14 17 21	24 28 31
13	1139	1173	1206	1239	1271	1303	1335	1367	1399	1430	3 6 10	13 16 19	23 26 29
14	1461	1492	1523	1553	1584	1614	1644	1673	1703	1732	3 6 9	12 15 18	21 24 27
15	1761	1790	1818	1847	1875	1903	1931	1959	1987	2014	3 6 8	11 14 17	20 22 25
16	2041	2068	2095	2122	2148	2175	2201	2227	2253	2279	3 5 8	11 13 16	18 21 24
17	2304	2330	2355	2380	2405	2430	2455	2480	2504	2529	2 5 7	10 12 15	17 20 22
18	2553	2577	2601	2625	2648	2672	2695	2718	2742	2765	2 5 7	9 12 14	16 19 21
19	2788	2810	2833	2856	2878	2900	2923	2945	2967	2989	2 4 7	9 11 13	16 18 20
20	3010	3032	3054	3075	3096	3118	3139	3160	3181	3201	2 4 6	8 11 13	15 17 19
21	3222	3243	3263	3284	3304	3324	3345	3365	3385	3404	2 4 6	8 10 12	14 16 18
22	3424	3444	3464	3483	3502	3522	3541	3560	3579	3598	2 4 6	8 10 12	14 16 17
23	3617	3636	3655	3674	3692	3711	3729	3747	3766	3784	2 4 6	7 9 11	13 15 17
24	3802	3820	3838	3856	3874	3892	3909	3927	3945	3962	2 4 5	7 9 11	12 14 16
25	3979	3997	4014	4031	4048	4065	4082	4099	4116	4133	2 4 5	7 9 10	12 14 16
26	4150	4166	4183	4200	4216	4232	4249	4265	4281	4298	2 3 5	7 8 10	11 13 15
27	4314	4330	4346	4362	4378	4393	4409	4425	4440	4456	2 3 5	6 8 9	11 12 14
28	4472	4487	4502	4518	4533	4548	4564	4579	4594	4609	2 3 5	6 8 9	11 12 14
29	4624	4639	4654	4669	4683	4698	4713	4728	4742	4757	1 3 4	6 7 9	10 12 13
30	4771	4786	4800	4814	4829	4843	4857	4871	4886	4900	1 3 4	6 7 9	10 11 13
31	4914	4928	4942	4955	4969	4983	4997	5011	5024	5038	1 3 4	5 7 8	10 11 12
32	5051	5065	5079	5092	5105	5119	5132	5145	5159	5172	1 3 4	5 7 8	9 11 12
33	5185	5198	5211	5224	5237	5250	5263	5276	5289	5302	1 3 4	5 7 8	9 11 12
34	5315	5328	5340	5353	5366	5378	5391	5403	5416	5428	1 2 4	5 6 8	9 10 11
35	5441	5453	5465	5478	5490	5502	5514	5527	5539	5551	1 2 4	5 6 7	9 10 11
36	5563	5575	5587	5599	5611	5623	5635	5647	5658	5670	1 2 4	5 6 7	8 10 11
37	5682	5694	5705	5717	5729	5740	5752	5763	5775	5786	1 2 4	5 6 7	8 9 11
38	5798	5809	5821	5832	5843	5855	5866	5877	5888	5899	1 2 3	5 6 7	8 9 10
39	5911	5922	5933	5944	5955	5966	5977	5988	5999	6010	1 2 3	4 5 7	8 9 10
40	6021	6031	6042	6053	6064	6075	6085	6096	6107	6117	1 2 3	4 5 6	8 9 10
41	6128	6138	6149	6160	6170	6180	6191	6201	6212	6222	1 2 3	4 5 6	7 8 9
42	6232	6243	6253	6263	6274	6284	6294	6304	6314	6325	1 2 3	4 5 6	7 8 9
43	6335	6345	6355	6365	6375	6385	6395	6405	6415	6425	1 2 3	4 5 6	7 8 9
44	6435	6444	6454	6464	6474	6484	6493	6503	6513	6522	1 2 3	4 5 6	7 8 9
45	6532	6542	6551	6561	6571	6580	6590	6599	6609	6618	1 2 3	4 5 6	7 8 9
46	6628	6637	6646	6656	6665	6675	6684	6693	6702	6712	1 2 3	4 5 6	7 7 8
47	6721	6730	6739	6749	6758	6767	6776	6785	6794	6803	1 2 3	4 5 6	7 7 8
48	6812	6821	6830	6839	6848	6857	6866	6875	6884	6893	1 2 3	4 5 6	7 7 8
49	6902	6911	6920	6928	6937	6946	6955	6964	6972	6981	1 2 3	4 4 5	6 7 8
50	6990	6998	7007	7016	7024	7033	7042	7050	7059	7067	1 2 3	3 4 5	6 7 8
51	7076	7084	7093	7101	7110	7118	7126	7135	7143	7152	1 2 3	3 4 5	6 7 8
52	7160	7168	7177	7185	7193	7202	7210	7218	7226	7235	1 2 3	3 4 5	6 7 7
53	7243	7251	7259	7267	7275	7284	7292	7300	7308	7316	1 2 2	3 4 5	6 6 7
54	7324	7332	7340	7348	7356	7364	7372	7380	7388	7396	1 2 2	3 4 5	6 6 7
N	0	1	2	3	4	5	6	7	8	9	1 2 2	4 5 6	7 8 9

The proportional parts are stated in full for every tenth at the right-hand side. The logarithm of any number of four significant figures can be read directly by add-

(continued)—LOGARITHMS TO BASE 10

N	0	1	2	3	4	5	6	7	8	9	1	2	3	4	5	6	7	8	9
55	7404	7412	7419	7427	7435	7443	7451	7459	7466	7474	1	2	2	3	4	5	5	6	7
56	7482	7490	7497	7505	7513	7520	7528	7536	7543	7551	1	2	2	3	4	5	5	6	7
57	7559	7566	7574	7582	7589	7597	7604	7612	7619	7627	1	1	2	3	4	5	5	6	7
58	7634	7642	7649	7657	7664	7672	7679	7686	7694	7701	1	1	2	3	4	4	5	6	7
59	7709	7716	7723	7731	7738	7745	7752	7760	7767	7774	1	1	2	3	4	4	5	6	7
60	7782	7789	7796	7803	7810	7818	7825	7832	7839	7846	1	1	2	3	4	4	5	6	6
61	7853	7860	7868	7875	7882	7889	7896	7903	7910	7917	1	1	2	3	3	4	5	6	6
62	7924	7931	7938	7945	7952	7959	7966	7973	7980	7987	1	1	2	3	3	4	5	5	6
63	7993	8000	8007	8014	8021	8028	8035	8041	8048	8055	1	1	2	3	3	4	5	5	6
64	8062	8069	8075	8082	8089	8096	8102	8109	8116	8122	1	1	2	3	3	4	5	5	6
65	8129	8136	8142	8149	8156	8162	8169	8176	8182	8189	1	1	2	3	3	4	5	5	6
66	8195	8202	8209	8215	8222	8228	8235	8241	8248	8254	1	1	2	3	3	4	5	5	6
67	8261	8267	8274	8280	8287	8293	8299	8306	8312	8319	1	1	2	3	3	4	5	5	6
68	8325	8331	8338	8344	8351	8357	8363	8370	8376	8382	1	1	2	3	3	4	4	5	6
69	8388	8395	8401	8407	8414	8420	8426	8432	8439	8445	1	1	2	3	3	4	4	5	6
70	8451	8457	8463	8470	8476	8482	8488	8494	8500	8506	1	1	2	3	3	4	4	5	6
71	8513	8519	8525	8531	8537	8543	8549	8555	8561	8567	1	1	2	3	3	4	4	5	6
72	8573	8579	8585	8591	8597	8603	8609	8615	8621	8627	1	1	2	3	3	4	4	5	6
73	8633	8639	8645	8651	8657	8663	8669	8675	8681	8686	1	1	2	2	3	4	4	5	5
74	8692	8698	8704	8710	8716	8722	8727	8733	8739	8745	1	1	2	2	3	4	4	5	5
75	8751	8756	8762	8768	8774	8779	8785	8791	8797	8802	1	1	2	2	3	3	4	5	5
76	8808	8814	8820	8825	8831	8837	8842	8848	8854	8859	1	1	2	2	3	3	4	4	5
77	8865	8871	8876	8882	8887	8893	8899	8904	8910	8915	1	1	2	2	3	3	4	4	5
78	8921	8927	8932	8938	8943	8949	8954	8960	8965	8971	1	1	2	2	3	3	4	4	5
79	8976	8982	8987	8993	8998	9004	9009	9015	9020	9025	1	1	2	2	3	3	4	4	5
80	9031	9036	9042	9047	9053	9058	9063	9069	9074	9079	1	1	2	2	3	3	4	4	5
81	9085	9090	9096	9101	9106	9112	9117	9122	9128	9133	1	1	2	2	3	3	4	4	5
82	9138	9143	9149	9154	9159	9165	9170	9175	9180	9186	1	1	2	2	3	3	4	4	5
83	9191	9196	9201	9206	9212	9217	9222	9227	9232	9238	1	1	2	2	3	3	4	4	5
84	9243	9248	9253	9258	9263	9269	9274	9279	9284	9289	1	1	2	2	3	3	4	4	5
85	9294	9299	9304	9309	9315	9320	9325	9330	9335	9340	1	1	2	2	3	3	4	4	5
86	9345	9350	9355	9360	9365	9370	9375	9380	9385	9390	1	1	2	2	3	3	4	4	5
87	9395	9400	9405	9410	9415	9420	9425	9430	9435	9440	1	1	2	2	3	3	4	4	5
88	9445	9450	9455	9460	9465	9469	9474	9479	9484	9489	0	1	1	2	2	3	3	4	4
89	9494	9499	9504	9509	9513	9518	9523	9528	9533	9538	0	1	1	2	2	3	3	4	4
90	9542	9547	9552	9557	9562	9566	9571	9576	9581	9586	0	1	1	2	2	3	3	4	4
91	9590	9595	9600	9605	9609	9614	9619	9624	9628	9633	0	1	1	2	2	3	3	4	4
92	9638	9643	9647	9652	9657	9661	9666	9671	9675	9680	0	1	1	2	2	3	3	4	4
93	9685	9689	9694	9699	9703	9708	9713	9717	9722	9727	0	1	1	2	2	3	3	4	4
94	9731	9736	9741	9745	9750	9754	9759	9763	9768	9773	0	1	1	2	2	3	3	4	4
95	9777	9782	9786	9791	9795	9800	9805	9809	9814	9818	0	1	1	2	2	3	3	4	4
96	9823	9827	9832	9836	9841	9845	9850	9854	9859	9863	0	1	1	2	2	3	3	4	4
97	9868	9872	9877	9881	9886	9890	9894	9899	9903	9908	0	1	1	2	2	3	3	4	4
98	9912	9917	9921	9926	9930	9934	9939	9943	9948	9952	0	1	1	2	2	3	3	3	4
99	9956	9961	9965	9969	9974	9978	9983	9987	9991	9996	0	1	1	2	2	3	3	3	4
N	0	1	2	3	4	5	6	7	8	9	1	2	3	4	5	6	7	8	9

ing the proportional part corresponding to the fourth figure to the tabular number corresponding to the first three figures. There may be an error of 1 in the last place.

Airflow Calibration - SQUEEZE-BULB, GAS AND VAPOR DETECTION SYSTEMS

Object

To calibrate squeeze-bulb devices using the soap bubble meter as a primary standard for sampling devices which require a low rate of airflow.

5. beaker
6. hose attachment

Theory

The bubble meter consists of an inverted burette with a soap bubble formed and adhering to the internal surface wall. As the air is evacuated by the sampling device through the discharge orifice the bubble will move in the direction of the airflow. This will permit recording of the volume per time sampled.

Equipment

1. burette
2. soap solution
3. squeeze-bulb device
4. ring stand

Procedure

Pour the soap solution gently, to avoid foaming, into a clean burette and roll burette slowly as the soap is returned to the beaker to insure coating of the entire interior surface. Clamp the burette into the ring stand in an inverted position. Raise the beaker to the bottom of the burette and form a bubble by touching the surface of the soap to the mouth of the burette. Draw the bubble to the calibrated area of the burette by using suction. Form three or four bubbles by the same method. Rotate the burette on the ring stand so the bubbles will traverse in a horizontal direction. Attach the device to be calibrated to the burette and measure time needed to traverse given volume of air.

Reference

1. Kusnetz, H.L., "Airflow Calibration of Direct Reading Colorimetric Devices." AIHA Journal, 21:4, August (1960).

Airflow Calibration - GREENBURG-SMITH IMPINGER

Object

To calibrate the flow rate through an all-glass Greenburg-Smith impinger.

Theory

In the standard procedure for using a Greenburg-Smith impinger, a suction pressure of 3" of mercury is applied to the exhaust side. One cubic foot per minute of air will be drawn into the impinger under these conditions, if the orifice is 2.3 mm in diameter. Since glass is not a precision construction material, it cannot be assumed that the

orifice will be exactly 2.3 mm. Small variations in orifice size will cause significant departures in flow rate from 1cfm. It is necessary to calibrate each impinger, and use the flow rate found in subsequent work with that impinger.

The impinger should be calibrated against a primary or accurate secondary standard. In this experiment, a rotameter (secondary standard) will be used. It will be assumed, for purposes of this experiment, that the rotameter is in proper condition.

Equipment

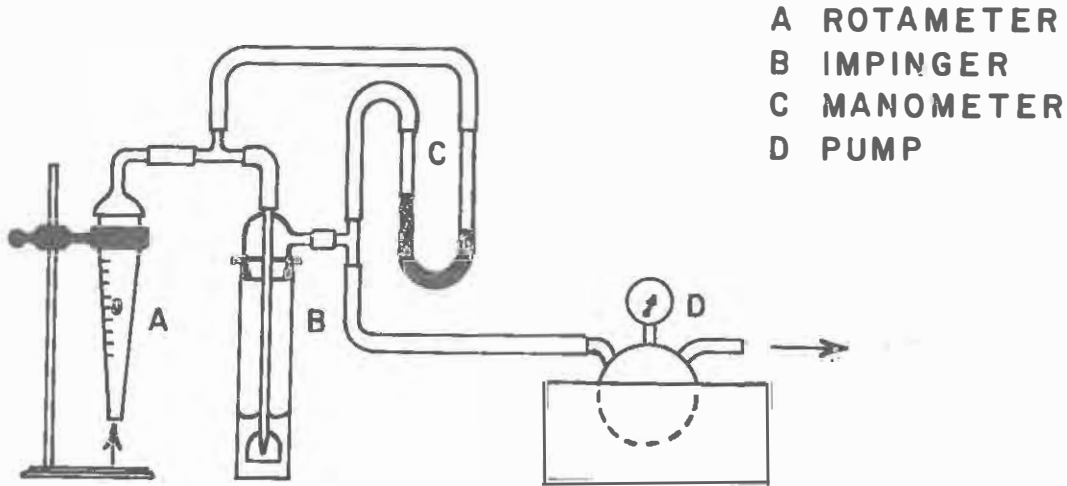

Procedure

Turn on the pump and adjust the suction until the mercury manometer reads 3" Hg. Read the rotameter and mark the vacuum gauge of the pump at this flow.

Translate the rotameter reading into cfm, make pressure and temperature corrections, if necessary.

Record the correct flow for each impinger used under conditions outlined in the procedure.

Calculations

Impinger Number	Rotameter Reading	Corrected Airflow cfm

Prepared by: Glen W. Sutton

Airflow Calibration - MIDGET IMPINGER

Object

To use a wet test meter as a means of calibrating the flow rate through a midget impinger.

Theory

A commonly used flow producing apparatus for the midget impinger consists of a hand operated pump assembly with an adjustable negative pressure regulator and a negative pressure gauge. Its design is such that when the regulator is adjusted to maintain a pressure drop across the impinger of 12" H₂O then a 0.1 cfm sample will be drawn through the impinger flask. The flow rate and the negative pressure gauge should be checked, then rechecked at regular intervals to insure that there has been no change with usage. The flow rate should be maintained within $\pm 3\%$ of the rated flow.

Equipment

1. Wet test meter
2. Midget impinger pump
3. Midget impinger flask
4. Manometer

Procedure

Connect the impinger flask to the pump by means of a short section of

rubber tubing with one leg of a water manometer connected in the line near the impinger flask. With sampling medium in the flask connect the wet test meter to the impinger with the other leg of the manometer connected into this line near the impinger. The manometer should now indicate the pressure drop across the impinger. Crank the pump at a speed (about 50 rpm) which will maintain a steady 12" pressure drop as indicated on the manometer, adjusting the negative pressure regulator if necessary. Make three runs to determine the flow rate through each impinger timing complete revolutions of the wet test meter on each run.

Disconnect the wet test meter and the manometer from the entrance to the impinger. Crank the pump to again maintain 12" negative pressure on the manometer adjusting the negative pressure regulator if necessary. This final adjustment is necessary because of the additional negative pressure caused by the wet test meter when it was in the system. Mark the negative pressure gauge to indicate the correct negative pressure for operating the pump. Calculate the rate of air flow through the impinger. Pressure and temperature corrections should be made when applicable.

Calculations

<u>Impinger Number</u>	<u>Meter Reading cu. ft.</u>	<u>Elapsed Time min.</u>	<u>Flow Rate cfm</u>

Prepared by: Glen W. Sutton

Airflow Calibration - FIXED FLOW ELECTROSTATIC PRECIPITATOR

Object

To calibrate the rate of airflow of a fixed flow electrostatic precipitator with a thermoanemometer.

Theory

The fixed flow electrostatic precipitator consists of a high voltage power supply and a sampling head, which contains an ionizing center wire or electrode, a collection tube, and a small capacitor motor with a centrifugal blower. The characteristics of the blower are such that the slightest increase ($<1/4''$ H₂O) of resistance drastically reduces the rate of airflow, and for this reason the usual means of calibration cannot be employed. A technique which avoids any noticeable resistance to airflow must therefore be used. One method is the use of a thermoanemometer, which is based on the principle that air flowing over a heated wire or heated thermometer bulb reduces the electrical resistance of the wire and the temperature of the thermometer. This heated bulb thermometer is used in conjunction with a standard or unheated thermometer. When both thermometer bulbs are placed in an air stream, the difference in temperature can be related directly to the velocity of air passing over the bulbs. The sensing heads (or bulbs) of the thermoanemometers are small enough to avoid noticeable resistance to air flow and accurate enough to provide better reproducibility than most secondary calibration standards.

Another means of calibrating this instrument is the null point or null pressure method which will be discussed in Section E-5 for variable flow electrostatic samples.

Equipment

1. Electrostatic Precipitator
2. Thermoanemometer with matched thermometers (capable of accurately indicating temperature to 0.05°C)
3. Precipitator tubes
4. Calibrated flowmeter (range 0-20 cfm)
5. Compressed air source
6. Wet-test meter

Procedure

In order to save time, a calibration curve of airflow versus thermoanemometer temperature differences was previously prepared. This was done as follows: The heated and unheated thermometers were inserted at right angles to each other about midway in a precipitator collecting tube (Figure 1). The heated thermometer was placed downstream from the unheated thermometer to avoid any heating of the air stream by the thermal element. One additional tube was joined to the first by tape and the assembly supported in a wooden frame. The outlet side of the collecting tube (exhaust end - Figure 2) was attached to the inlet of a wet-test meter (3 cubic feet mid-range capacity). A source of suction was connected to the outlet side of the wet-test meter, and the suction adjusted to produce an airflow of 3.0 cfm as measured by the wet-test meter (Figure 2). The two thermometers (graduated to read accurately to 0.05°C) were allowed to reach equilibrium (three identical readings one minute apart) and the test was repeated for a sufficient number of flow rates above and below 3.0 cfm to establish a calibration curve.

The procedure is as follows: Turn on the precipitator blower and read the thermometers at one-minute intervals. Repeat this procedure until three successive temperature differentials are the same. Do not create too much air movement in the vicinity of the experiment as this will give erroneous results.

Prepared by: Stanley J. Reno

- 1. ELECTROSTATIC PRECIPITATOR TUBES
- 2. STANDARD THERMOMETER
- 3. HEATED WIRE THERMOMETER

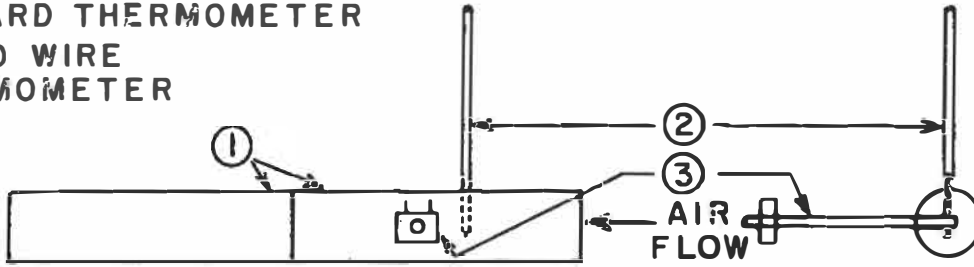

Figure 1.

- 4-PRECIPITATOR TUBES WITH THERMOMETERS
- 5-THERMOANEMOMETER
- 6-WET GAS METER
- 7-SOURCE OF VACUUM

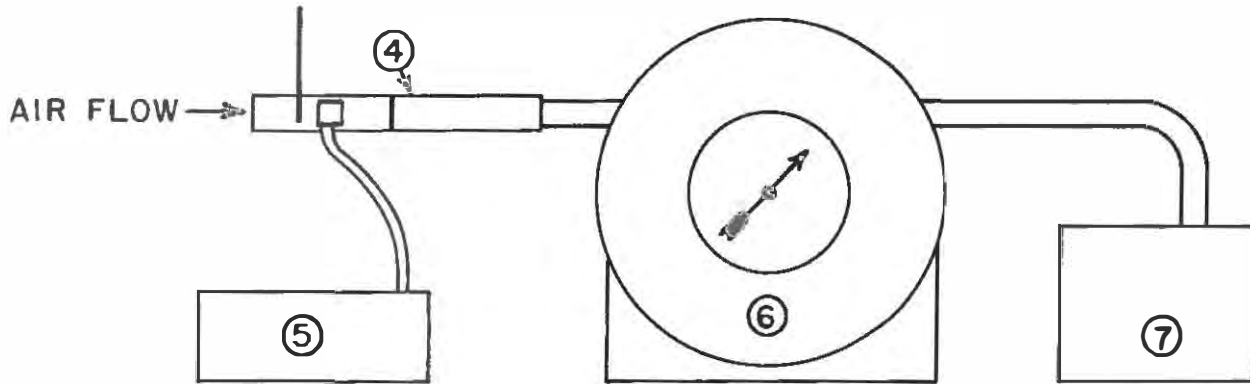
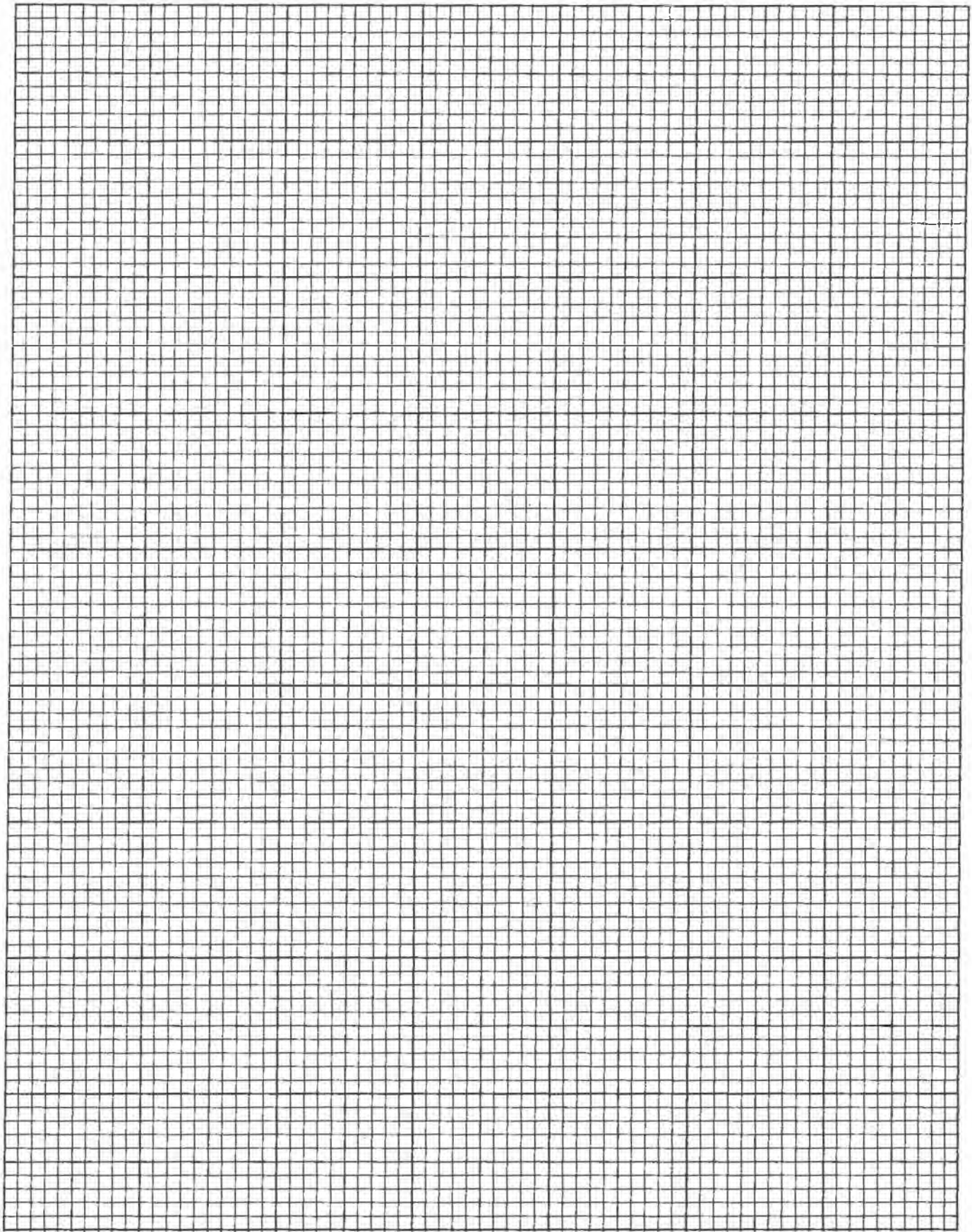

Figure 2.

Calculations

Thermometer Readings			Voltage on Heated Thermometer	Airflow from Curve cfm
Heated	cold	ΔT		



Airflow Calibration - VARIABLE FLOW ELECTROSTATIC SAMPLER

Object

To calibrate the rate of airflow of a variable flow electrostatic precipitator.

Theory

The source of suction in the sampling head of the electrostatic precipitator consists of a small capacitor motor with a centrifugal blower. The characteristics of the blower are such that the rate of airflow decreases considerably with increase in resistance ($< \frac{1}{4}$ " H₂O) and for this reason methods of calibration are used which do not result in additional resistance to the airflow.

This instrument may be calibrated by either the thermoanemometer method outlined in Section E-4 or the null point

or null pressure method described in this Section.

The null point method utilizes a simple box or container with a plastic diaphragm cover. Metered air from a pump or compressed air line is introduced into one side of the box and air is removed by the electrostatic precipitator, (ESP), blower from another side of the box. If air is introduced into the container at the same rate as it is removed a null point or atmospheric pressure is obtained within the box. An inclined manometer, attached to the box, is used to make certain that null or atmospheric pressure is attained. The airflow can be adjusted due to the plastic diaphragm, without rupturing or collapsing the container. Care should be taken to avoid introducing air directly across the precipitator inlet as it is possible to force air through the blower and still obtain a null pressure within the box.

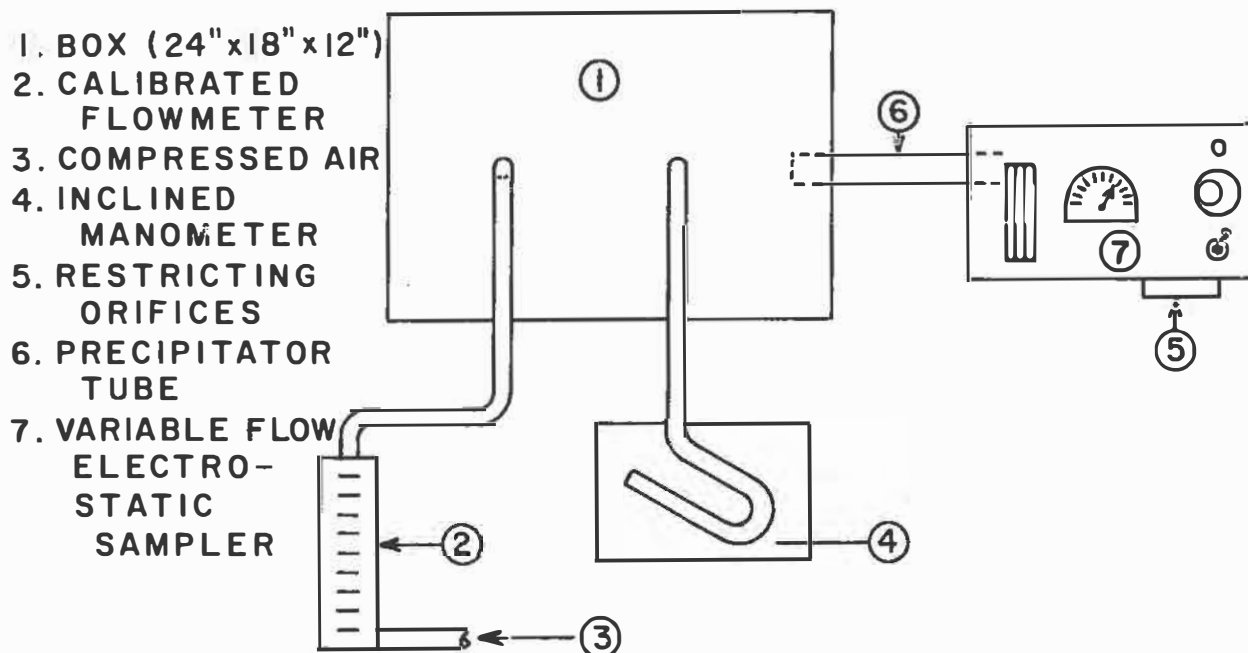

Figure 1.

Prepared by: Stanley J. Reno

Equipment

1. Variable Flow Electrostatic Precipitator (ESP)
2. Precipitator tubes
3. Cardboard box with plastic cover
4. Inclined Manometer
5. Compressed air source

Procedure

Turn on the precipitator and adjust the compressed air line (Figure 1) until a null is indicated by the inclined manometer - care should be taken in adjusting the airflow so that the container diaphragm will not be ruptured.

Record the rate of flow of the compressed air. Repeat the procedure with other orifices for a variable flow precipitator. Calculate flow rate for the ESP using the formula $Q = AV$, where Q = the rate of flow in cfm, V = the velocity in feet per minute and A = the area of the precipitator tube (0.01126 square feet).

A variable flow electrostatic sampler can be calibrated also by the thermoanemometer method (Figure 2) by repeating the procedure outlined in Section E-4 with various orifices supplied with the sampler.

1. VARIABLE FLOW ELECTROSTATIC SAMPLER
2. RESTRICTING ORIFICES
3. PRECIPITATOR TUBES WITH THERMOMETERS

4. THERMOANEMOMETER

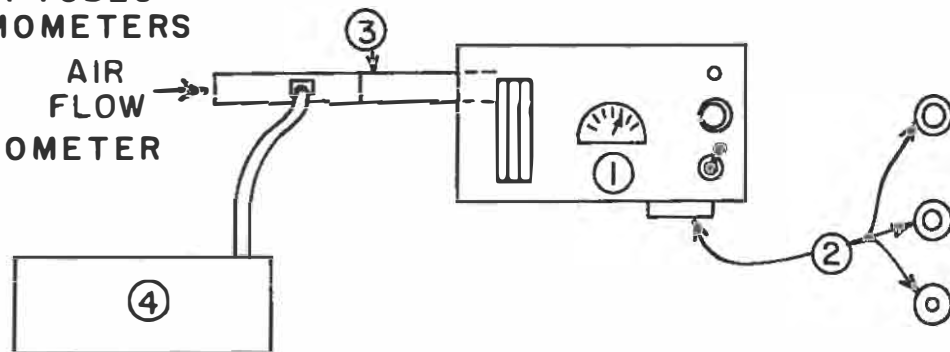
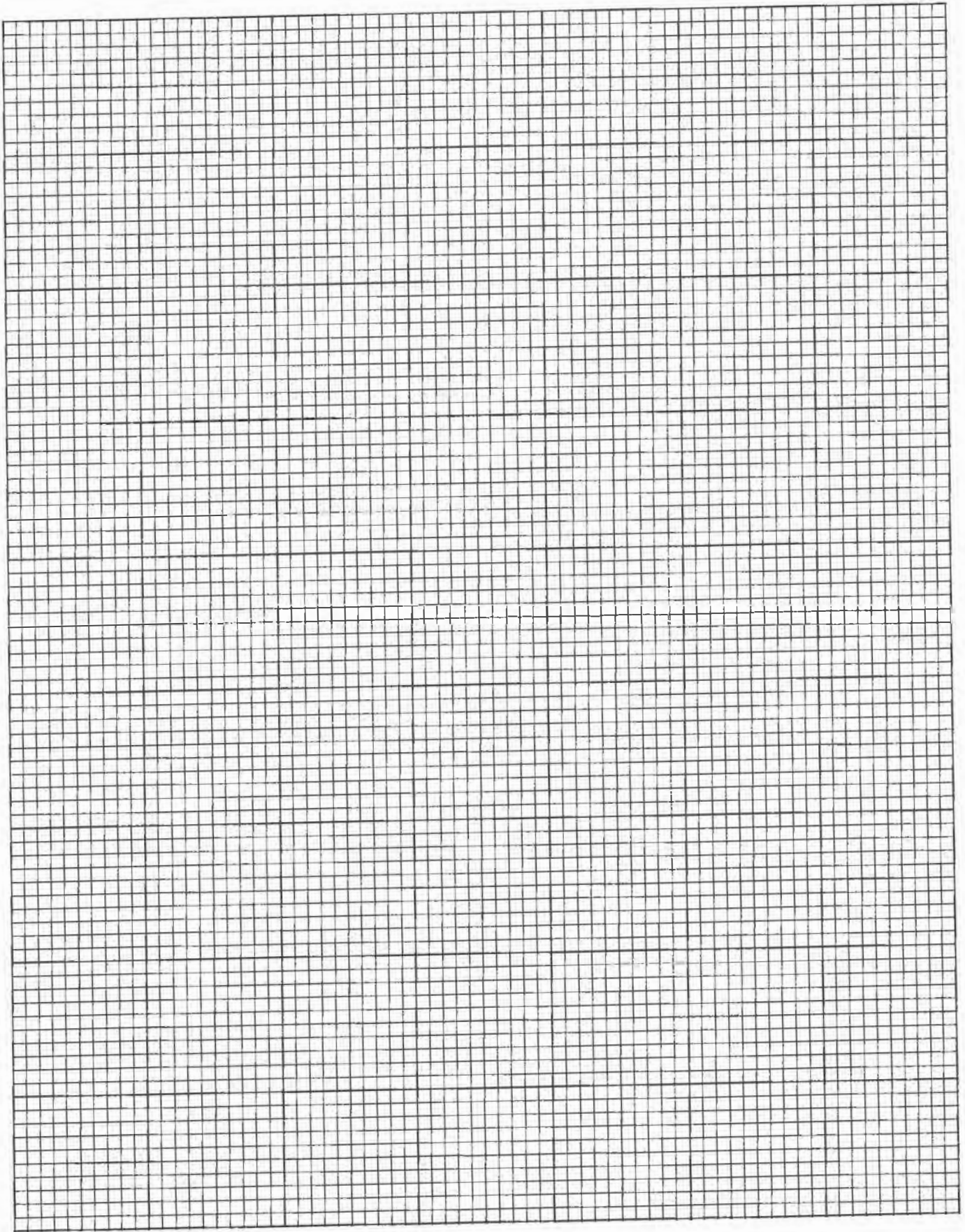

Figure 2.



Airflow Calibration - FILTER PAPER SAMPLER

Object

To prepare an airflow calibration curve for a filter paper sampling device using an orifice meter and a secondary standard.

Theory

Different types of filter media offer a range of resistance to airflow. The resistance to flow increases as the sample of dust or fume is deposited on the filter. It is therefore necessary to calibrate the sampling device to determine the rate of airflow under various conditions. Several metering devices are available for this purpose but in this experiment, an orifice meter will be calibrated against a rotameter. A theoretical discussion on the operation of an orifice meter is given by Jacobs¹ and on the rotameter by Perry². Further theoretical considerations can be found in standard references on airflow measurement.

Equipment

1. Filter paper sample holder
2. Whatman #41 filter paper or other filter media
3. Orifice meter
4. Mercury U-tube manometer
5. Rotameter
6. Source of suction - pump or vacuum line
7. Rubber tubing and metal T's

Procedure

Connect apparatus as shown in the diagram. Apply suction until rotameter reads about 1 cfm. Record readings of rotameter, U-tube manometer and orifice meter then repeat at four other rates of airflow between 0 and 1 cfm. Correct rotameter reading to standard conditions of pressure and temperature by means of gas law equation to give actual airflow as ordinates and orifice meter reading as abscissa. Use graph paper on page E-6-2.

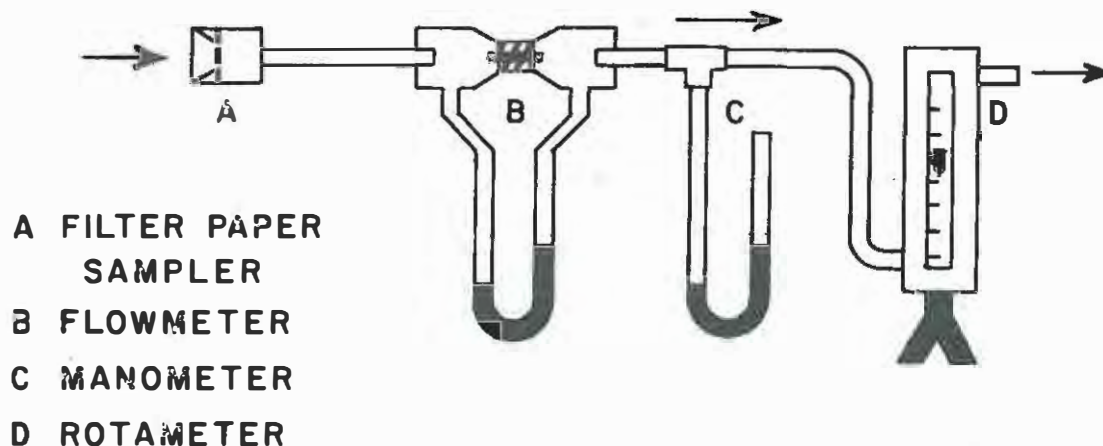

Calculations

<u>Rotaneter Reading</u>	<u>Indicated Airflow from Curve</u>	<u>Mercury Manometer</u>	<u>Room Temperature</u>	<u>Actual Airflow</u>	<u>Orifice Meter Reading</u>
------------------------------	---	------------------------------	-----------------------------	---------------------------	--------------------------------------

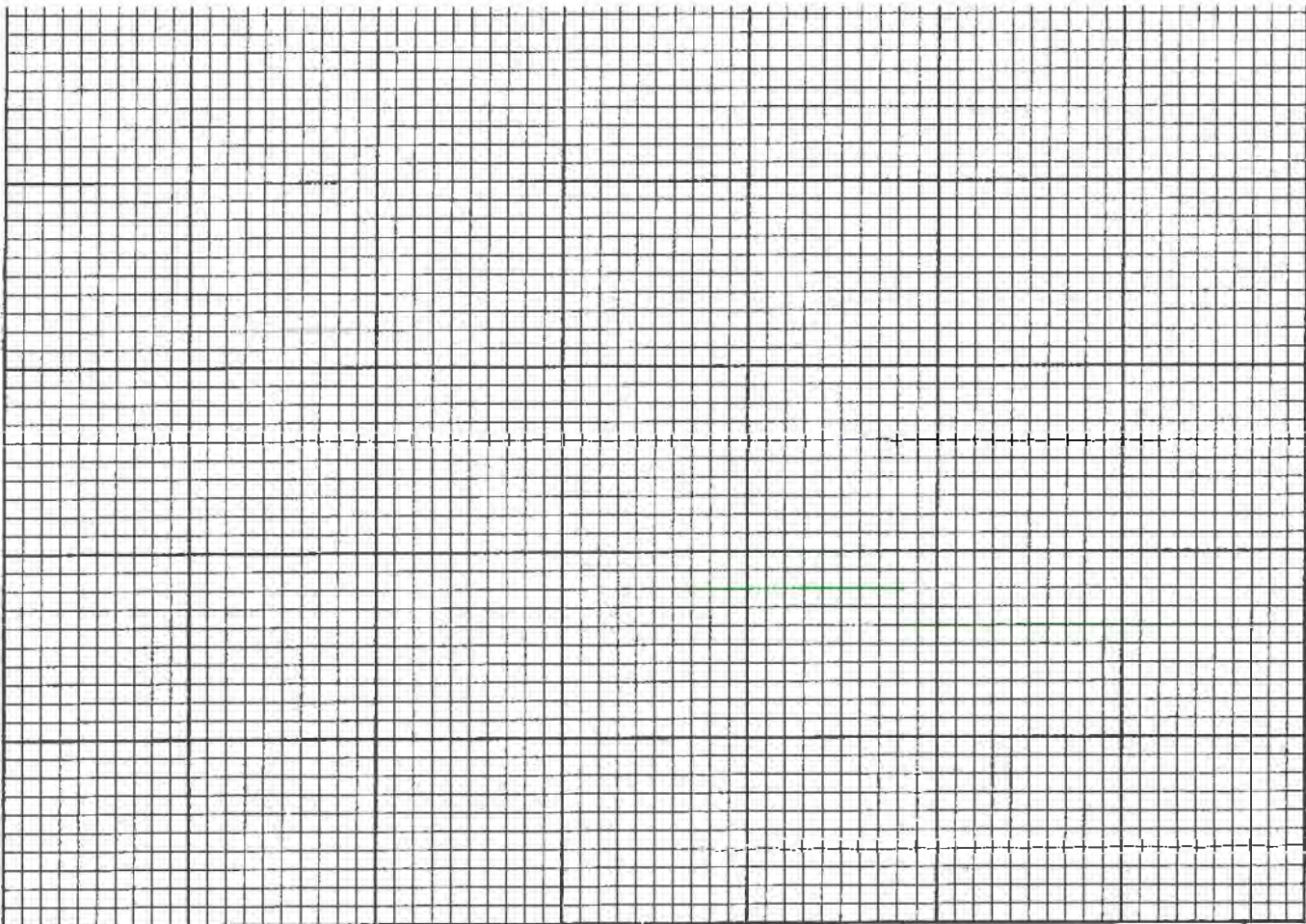

References

1. Jacobs, M.B.: The Analytical Chemistry of Industrial Poisons, Hazards and solvents. Interscience Publishers, Inc., New York, 2nd Ed., p. 63, 1949.
2. Perry, John H., editor: Chemical Engineers' Handbook. McGraw-Hill Book Company, Inc., New York, 3rd Ed., p. 408, 1950.

Airflow Calibration - HIGH VOLUME SAMPLER

Object

To calibrate the airflow indicator of a high volume air sampling device and prepare a calibration curve.

Theory

The pressure drop across the float of a rotameter (secondary standard) is essentially constant, however, the pressure drop across the entire device, including elbows, housing, etc., increases rapidly with increased flow. Therefore, to prevent the resistance of the rotameter and connections from affecting the flow characteristics of the sampling device a balanced flow system is utilized. To achieve this a measured quantity of air is provided to the sampler at atmospheric pressure.

Equipment

High volume sampler with filter
Magnehelic gauge or incline manometer
Rotameter, Venturi, orifice meter or any calibrated secondary standard of the appropriate range

By-pass valve to connections
Blower or second high volume sampler
Rheostat
Graph Paper

Procedure

1. Insert a clean filter in the sampler and connect the device as shown in the sketch below. If a blower is not available a second sampler without filter can be utilized.

2. Turn on the sampler and blower and adjust the by-pass valve from the blower so that the pressure gauge which is attached as close as possible to the filter reads zero with reference to atmosphere pressure. A rheostat may be used on the supply air blower motor in place of the by-pass valve.

3. Read and record airflow measured on the rotameter and flow indicating device on the instrument being calibrated.

4. With the sampler operating "simulate loading" of the filter by inserting

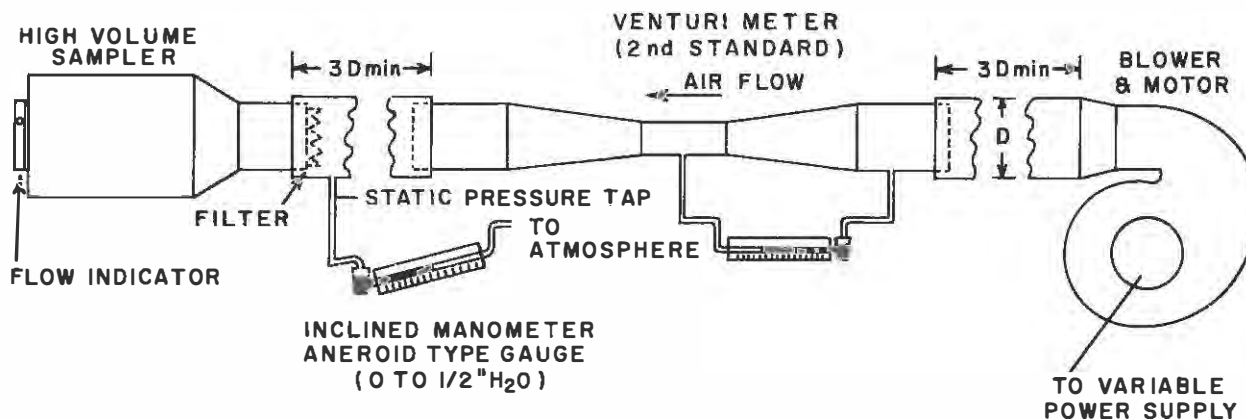

Prepared by: Julius H. Fanney, Jr.

small pieces of paper (thin tissue) into the filter housing and reconnect to the calibration train.

5. Readjust the blower by-pass to again obtain a zero pressure difference and note and record the readings on the

rotameter and flow indicator.

6. Repeat the procedure to obtain four or more sets of readings and draw a calibration curve of indicated and actual airflow on arithmetic graph paper.

References

1. Hama, George: Calibration of Airflow Measuring Instruments. Encyclopedia of Instrumentation for Industrial Hygiene. University of Michigan, Institute of Industrial Health, Ann Arbor, Michigan, pp 703 (1956).
2. Harrison, W.K., J.S. Nader, and F.S. Fugman: Constant Flow Regulator for the High-Volume Air Sampler. Amer. Ind. Hyg. Assoc. J. 21:115(1960).
3. Jackson, Howard W., F.B. Husted and W.R. LaRocque: A Compact Exhaust Ventilation Training Aid. Amer. Ind. Hyg. Assoc. J. 24:630 (1963).
4. Morley, Morgan J., and B.D. Tebbens: The Electrostatic Precipitator Dilution Method of Flow Measurement. Amer. Ind. Hyg. Assoc. Quar., 14:303 (1953).
5. _____. Air Pollution Measurements of the National Air Sampling Network: Public Health Service Publ. No. 637. GPO (1958) 259pp. Superintendent of Documents, Washington 25, D.C.
6. Sallee, Elgin D., and R. H. Miller: Industrial Hygiene Instruments. Amer. Ind. Hyg. Assoc. Quar., 17:193 (1956).
7. Silverman, L., and F.J. Viles: A High Volume Air Sampling and Filter Weighing Method for Certain Aerosols. J. Ind. Hyg. and Toxicol. 30:124(1948).

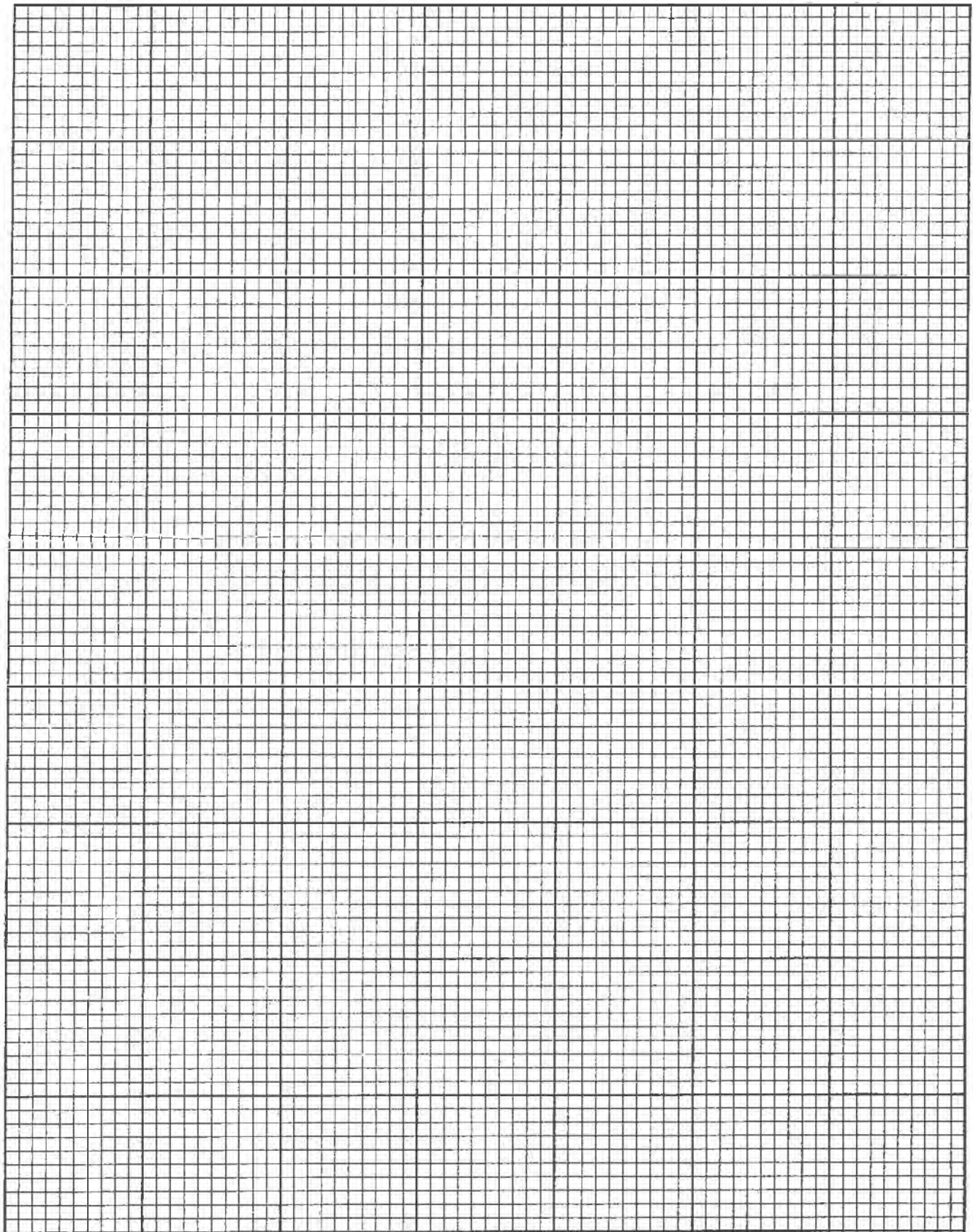

Preparation of Known Concentrations - STATIC METHOD

Object

To demonstrate a method of preparing known vapor concentrations in a large static chamber, and to demonstrate the associated use of known concentrations to calibrate instruments.

Theory

The static system involves the introduction of a known amount of gas or vapor into an enclosure of known volume. As air samples are withdrawn, the usual practice is to allow air to enter and replace the sample. One exception to this practice is to use a flexible chamber such as a plastic container or a balloon so that the removal of sample air from the original volume is compensated for by the collapse of the flexible container. Another method is the use of a chamber so large that removal of small samples do not significantly effect the vapor concentration.

With a fixed volume chamber and assuming instantaneous mixing of the incoming air with entire sample volume then the difference in concentration as a small volume is withdrawn is equal to the concentration times the fraction of the volume withdrawn or¹

$$C = C_0 e^{-\left(\frac{V}{V_0}\right)} \text{ or } 2.3 \log_{10} \frac{C_0}{C} = \frac{V}{V_0}$$

where:

C = the concentration at any time

V = the total volume of sample withdrawn

C₀ = the original concentration

V₀ = the chamber volume

For any sampling, then the concentration in the chamber is gradually reduced. If the average concentration of the sample can be allowed to vary 5% from the original, then the concentration can be reduced 10% during sampling.

Prepared by: Stanley J. Reno

Using the above equation 10.5% of the volume can be sampled while still maintaining an average concentration of 95% of the original. For purposes of this experiment the class will determine if the sample size is sufficient to significantly reduce the vapor concentration.

Equipment

1. 125 cubic feet stainless steel chamber with blower piping, circulating fan, ports and windows.

2. Syringe (1 ml.)

3. Reagent or contaminant to be introduced into chamber.

4. Various sampling instruments to be introduced during laboratory.

Procedure

Purge the chamber by opening the discharge and inlet valves, starting the pump and allowing the chamber to purge for a few minutes. Shut off pump and close all valves.

To calculate the volume of solvent necessary to produce a desired concentration in a given volume, the following calculation is made:

$$\text{ppm} = \frac{\text{wt. of solvent}}{\text{mol. wt.}} \times \frac{22.4}{\text{tank vol.}}$$

$$\times \frac{760}{P} \times \frac{273 + T^{\circ}\text{C}}{273} \times 10^6$$

$$\text{and ml of solvent} = \frac{\text{wt. of solvent}}{\text{sp g}}$$

Where:

P = barometric pressure

T = temperature of gas mixture in degrees centigrade

Inject the contaminant into the sampling port using the 1 cc syringe. Allow 5 minutes for mixing and take readings with the instruments provided by the instructor. Record readings in the Calculation Section of the Lab Procedure Sheet.

Preparation of Known Concentrations - DYNAMIC METHOD

Object

To prepare a known concentration by the dynamic method of mixing of a contaminant (CO) with room air. Indicator tubes will be calibrated at the known concentration prepared.

Theory

A cylinder of compressed air containing a contaminant of known concentration is used as a standard test gas for this air flow calibration procedure. The test gas (carbon monoxide) is diluted to the desired concentration by regulating the flow of the diluting air and the air containing the CO. The ratio of flow rates determines the dilution factor.¹ Air samples of the final air mixtures will be measured with several instruments.

Equipment

1. Mixture of carbon monoxide in air
2. Compressed air
3. Flowmeters - two required
4. Mixing chamber
5. CO indicator tubes

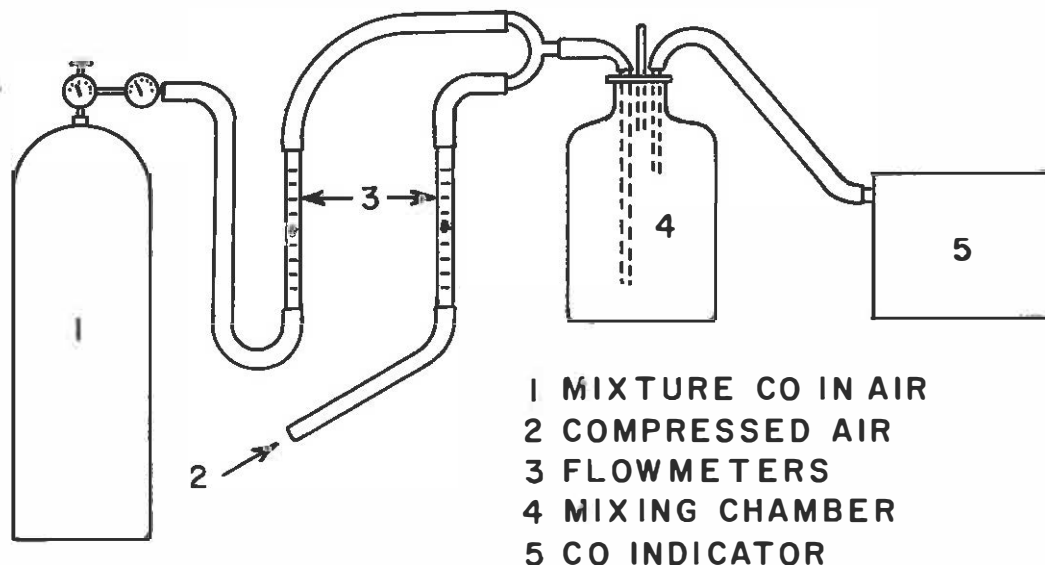

Procedure

Since the threshold limit value for carbon monoxide is 50 ppm², several points of calibration in this range should be made. For example, to obtain a point of calibration for 50 ppm using a reference gas mixture of 0.1% (1000 ppm), it must be diluted 1 to 19 parts of room air. Set flow rate of mixture from cylinder containing CO mixture at the desired rate and adjust the diluting air flow rate at 19 times this flow. The mixture will then contain 50 ppm.

In a similar manner with 0.1% concentration of CO gas flowing at 200 ml/min. calculate the dilution factors, dilution ratios and flow rates of room air required to produce concentrations of 25, 50, 75, and 100 ppm.

Allow the gas mixtures several minutes to reach equilibrium at each concentration before obtaining sample for calibration of each instrument.

Calculations

Volume cc/min.		Concentration of Mixture	Meter Reading hundredths of a percent	Indicator ppm		
Known CO in Air	Room Air			%		

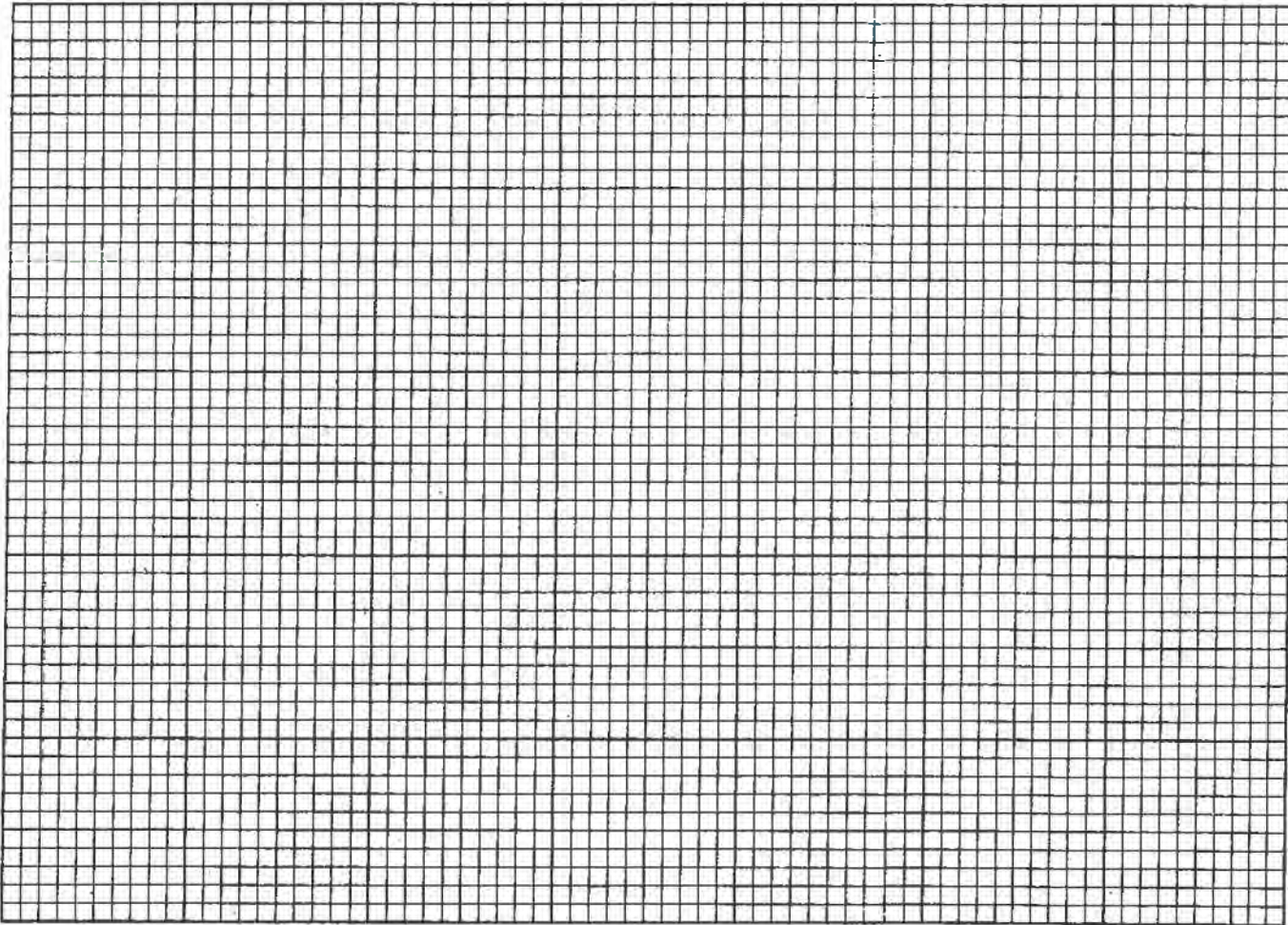

References

1. Powell, C.H., and A.D. Hosey, Ed.: The Industrial Environment - its Evaluation and Control, Division of Occupational Health, U. S. Public Health Service, Publication No. 614, 2nd Ed. Section B-8, prepared by H. E. Ayer and J. R. Lynch, U. S. Government Printing Office, Washington, D.C. (1965).
2. _____: The Threshold Limit Values for 1965, American Conference of Governmental Industrial Hygienists, Secretary-Treasurer, 1014 Broadway, Cincinnati, Ohio (1966).

Preparation of Known Concentrations - VAPOR PRESSURE METHOD

Object

To calibrate by the vapor pressure method a mercury vapor detector, using a dynamic flow system to produce known concentrations of mercury vapor.

Theory

At any given temperature, the approximate concentration of mercury in the vapor phase in contact with the liquid phase is reproducible under equilibrium conditions, and can be calculated.

The equilibrium (saturation) concentration of mercury vapor in contact with liquid mercury contained in an enclosure at atmospheric pressure is the partial pressure of mercury at the ambient temperature. This concentration can be diluted to any desired lower concentration for calibration purposes.

The mercury vapor detector is a direct reading instrument utilizing a photo-electric cell as the sensing element. A mercury vapor lamp, emitting 92% of its radiation at 2537A° , is the

Equipment

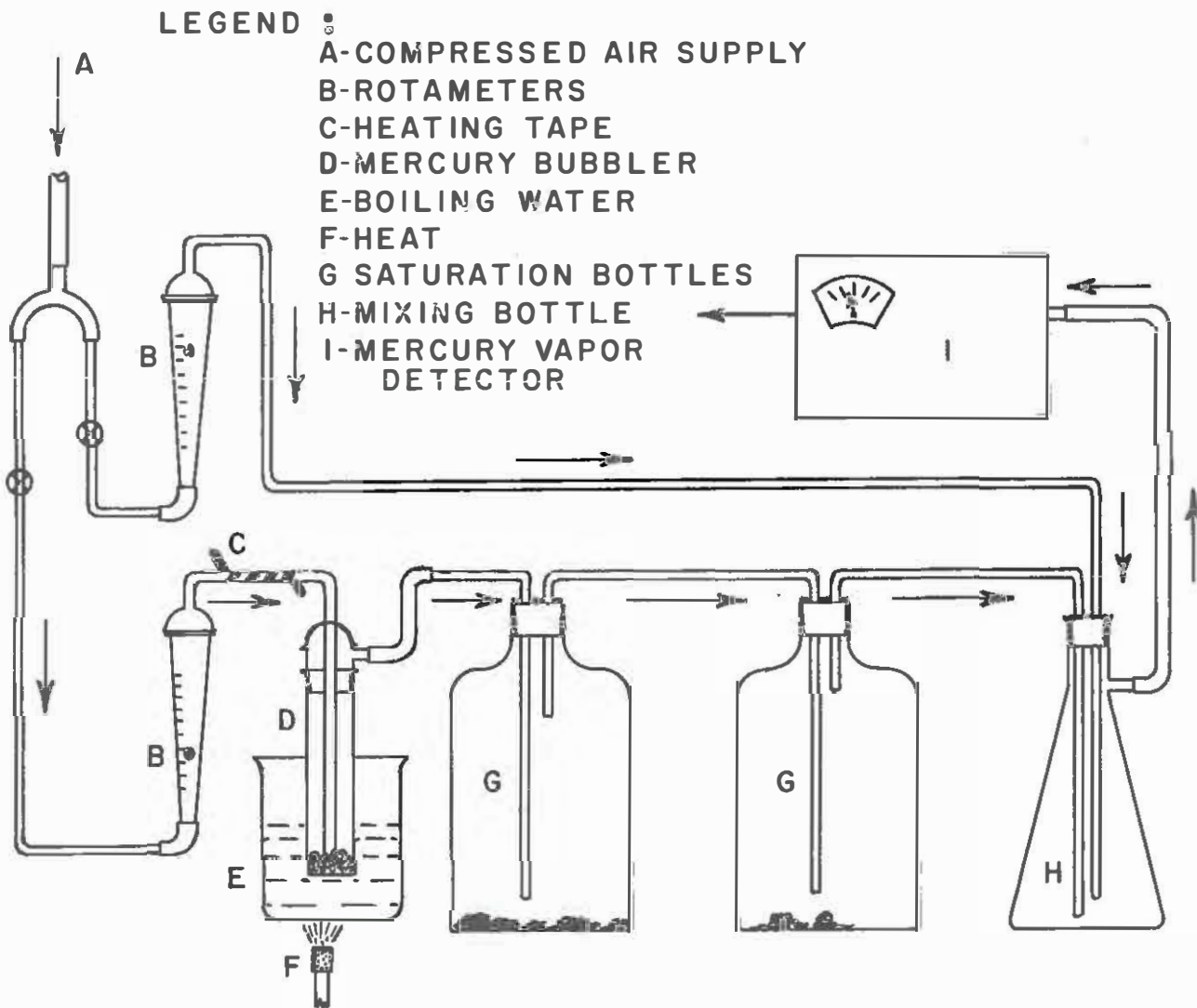

light source inside the meter. A fan draws an air stream between the U.V. lamp and the photocell. If any component of the air stream absorbs light at 2537A°, a scale deflection results. In addition to mercury, many solvent vapors such as benzol, toluol and acetone, and gases such as chlorine, ozone, sulfur dioxide and nitrogen dioxide also absorb U.V. in this region and will give meter readings. However, the instrument is far more sensitive to mercury vapor than to any other substance. A trace of mercury vapor will therefore interfere with the determination of any other gas or vapor, while an enormous concentration of another vapor would be necessary to interfere with a mercury determination.

Procedure

Assume that the mercury in the saturation flasks is at equilibrium concentration.

The flow rates should be adjusted to supply at least 5.5 lpm or slightly more because the mercury vapor detector samples at a rate of 5.5 lpm at atmospheric pressure.

Construct a calibration curve for the meter using four or more test concentrations in its operating range.

For each concentration, record the following:

1. Flow rates in the two rotameters.
2. Scale deflection of the mercury vapor detector. Allow several minutes for the system to reach equilibrium for each point of calibration before making a reading.
3. Temperature and pressure of the air entering the mercury vapor detector.

Calculate the concentration in mg/M³ at each of the four or more test points, and construct a calibration curve.

VAPOR PRESSURE OF MERCURY

Temperature	Vapor Pressure	Concentration at 1 atm.
°C	mm. Hg	mg/M ³
20	0.001201	12.9
21	0.001301	14.1
22	0.001426	15.4
23	0.001555	16.7
24	0.001691	18.2
25	0.001836	19.8
26	0.002000	21.5
27	0.002170	23.4
28	0.002359	25.4
29	0.002559	27.6
30	0.002777	29.8
31	0.003010	32.4
32	0.003261	35.2

Preparation of Known Concentrations - SINGLE CHAMBER DEPLETION METHOD

Object

To demonstrate the use of a large chamber, in which the amount of contaminant decreases constantly, for preparation of known vapor concentrations.

Theory

Assuming instantaneous and complete mixing of air and a contaminant in a container, it is possible to theoretically predict the concentration of contaminant at any time, with constant removal of the air mixture from the container. ¹

Equipment

1. 10 gallon glass container with glass tubing and circulating fan
2. Micro-syringe
3. Rotameters (2)
4. Vacuum pump
5. Portable flame ionization meter
6. Graph paper

Procedure

Calculate the volume of solvent necessary to produce a desired concentration in ppm in a chamber of given volume using the following formulae:

$$\text{ppm} = \frac{\text{wt. of solvent}}{\text{mol. wt.}} \times \frac{22.4}{\text{container}}$$

$$\times \frac{760}{P} \times \frac{273 + T^{\circ}\text{C}}{273} \times 10^6$$

$$\text{and ml of solvent} = \frac{\text{wt. of solvent}}{\text{sp.g.}}$$

Where:

P = barometric pressure

T = temperature of gas mixture
in degrees centigrade

Therefore:

$$\text{ml of solvent} = \frac{(\text{ppm})(\text{mol. wt.})}{\text{sp.g.}} \times$$

$$\frac{\text{tank vol. (liters)}}{22.4 \text{ liters/mol.}} \times \frac{P(\text{mm Hg})}{760} \times$$

$$\frac{273}{273 + T^{\circ}\text{C}} \times 10^{-6}$$

Where: P = barometric pressure
T = temperature of gas
mixture in °C.

Assuming instantaneous dilution, the concentration (C) at any time (t) after dilution commences (when withdrawing the sample at a known constant rate) varies directly as the original concentration (C₀), and inversely as e raised to the power vt/V, where vt is the volume withdrawn from a container (v = rate of flow), of volume V.

$$C = C_0 e^{-\left(\frac{v}{V}t\right)} \text{ or } 2.3 \log_{10} \frac{C_0}{C} = \left(\frac{v}{V}t\right)$$

By knowing the sampling rate and the original volume, a curve showing theoretical dilution (concentration expressed as percent of original vs. time (min.) can be plotted on semi-log or linear graph paper.

Use a micro-syringe and inject into the container the calculated ml of solvent to give the desired concentration - a quantity sufficient to produce a full-scale deflection on the instrument meter at the desired sensitivity. Begin sampling and record zero time when the meter indicator reaches approximately maximum scale deflection. Read the meter at suitable periods of time, e.g., every 5 minutes during a 30 minute period of sampling. Plot meter readings at the various times versus the theoretical concentration in ppm at those times.

Calculations

Solvent: _____ Specific Gravity: _____ Molecular Weight: _____

Time-min.	Calculated Concentration ppm*	Meter Reading	Time - min.	Calculated Concentration ppm*	Meter Reading
1.			11.		
2.			12.		
3.			13.		
4.			14.		
5.			15.		
6.			16.		
7.			17.		
8.			18.		
9.			19.		
10.			20.		

Scale Sensitivity: _____ Barometric Pressure: _____ Temperature: _____

*(obtain from curve showing theoretical dilution)

Reference

1. Powell, C.H., and A.D. Hosey, Ed. The Industrial Environment - its Evaluation and Control, Division of Occupational Health, U. S. Public Health Service, Publication No. 614, 2nd Ed., Section B-8 prepared by J.R. Lynch and H.E. Ayer, U. S. Government Printing Office, Washington, D.C. (1965).

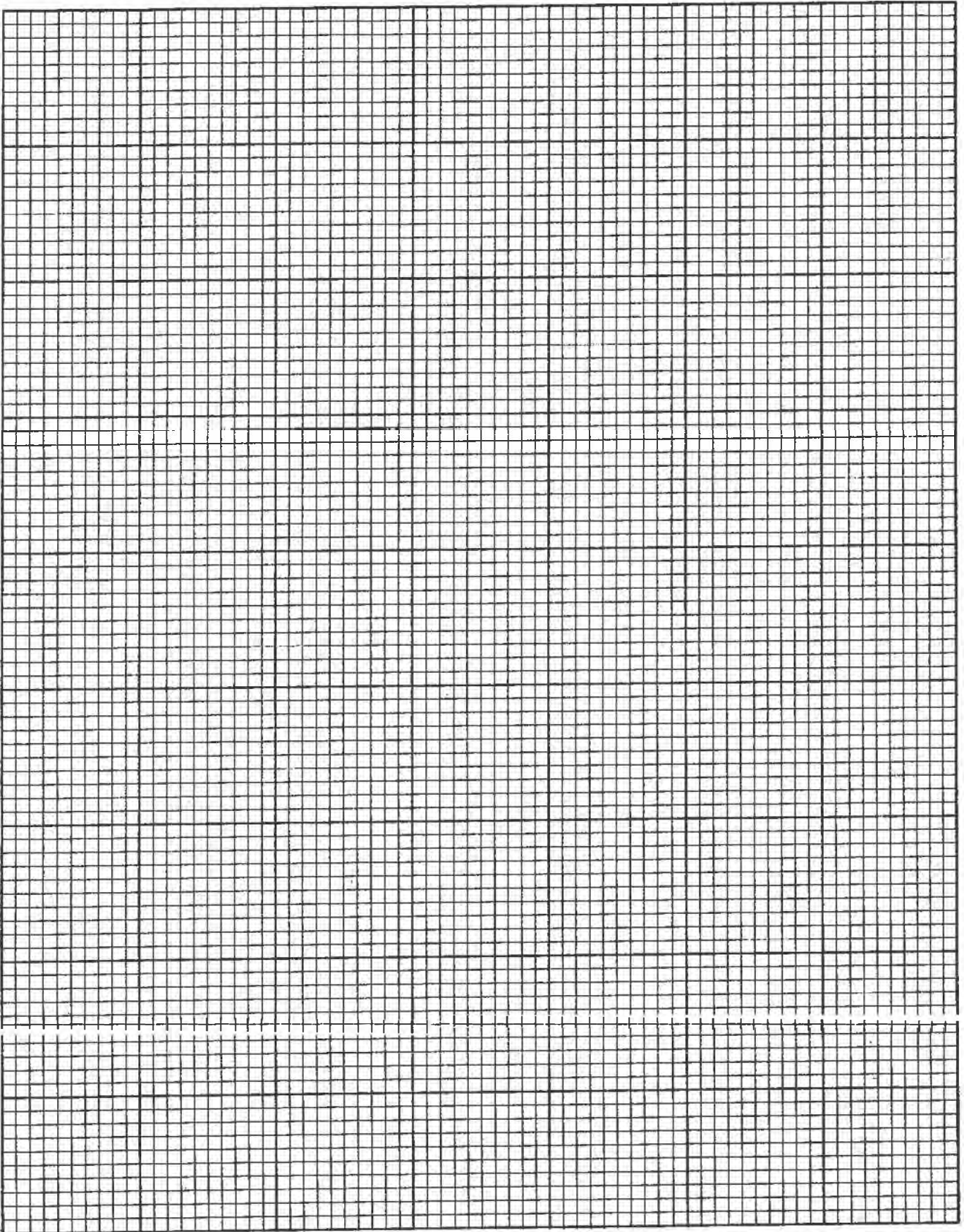

Laboratory Exercise - COUNTING AIRBORNE DUST

Object

To count and calculate the concentration of dust in an impinger sample, using a Dunn cell and a hemocytometer.

Theory

The median particle diameter of dust in an impinger sample is usually on the order of one micron. The smallest diameter particle usually visible with the optical system employed is also near one micron. The utmost effort must therefore be employed to count those particles near the limit of visibility to assure that the counts approach the true mean count. Settling time and other requirements of the "standard" method¹ must be followed closely to achieve a count within accepted limits.

Equipment

Microscope with 10X objective and 10X ocular

Research illuminator (or, preferably, a built in illuminator in the microscope)

Eyepiece graticule (Page, Whipple or Porton)

Dunn cells

Spencer bright-line hemocytometer

Veeder-Root counter

Stage micrometer

Procedure

1. Take the Dunn cell provided, place it on the microscope stage, and adjust microscope and illuminator for Kohler illumination as outlined on pages B-5-13 and 14², Volume I. With the eyepiece removed, make certain that the condenser iris diaphragm is at least 1/3 but no more than 2/3 open (with the eyepiece

in place this will cause the field to noticeably darken as the iris is brought from the full open position).

2. Moving to the edge of the hole in the Dunn cell top plate, make certain that the surface being examined is the upper surface of the base plate (this may be done by moving from top to bottom of the ground glass edge on the hole). Once having found the surface, only the fine focus adjustment should be used.

3. Count one or two fields to accustom the eyes to the task. When the 30 minute settling time has elapsed count five fields, one near the center and one in each quadrant, not too near the edge. Do not look through the microscope while selecting fields. Record each field separately. The fine focus adjustment may be used to bring very small particles into focus and to make certain that the particles counted are on the surface being examined. Particles which do not go into and out of focus as the fine focus is moved slightly are on the graticule or some other surface. Do not attempt to count with a number of particles in the graticule field.

4. Count a blank cell in the same manner as the sample. The net count is the sample count less the blank. Blank counts should not exceed 15 per 0.25 mm² cell area, and for precision the cell count should be at least four times the blank count.

5. Measure the graticule area with a stage micrometer by bringing the stage micrometer rulings into sharp focus (see page B-5-16), superimposing the rulings on the graticule, and measuring the length of the sides. Record the area of the graticule.

6. Using the heavier dust suspension, fill both sides of a Spencer bright-line hemocytometer. Count five major areas of 16 small squares (i.e., the

Prepared by: Howard E. Ayer

center and the four corners). If the total count achieved in this way is less than 100, count all 25 major areas. Repeat the procedure on the other side. Count a blank cell in the same manner as the sample.

Calculations

Calculate the number of particles in the impinger.

$$n = \frac{\text{net count per field (1000)}(\text{liquid volume})}{(\text{area of field} \times \text{depth of cell})}$$

The airborne dust concentrations is usually reported as millions of particles per cubic foot, so

$$\text{mppcf} = \frac{n}{\text{air volume sampled} \times 10^6}$$

References

1. Transactions of the Fifth Annual Meeting of the National Conference of Governmental Industrial Hygienists. Subcommittee on Standard Methods, Washington, D.C., 1942.
2. Powell, C.H., and A.D. Hosey, Ed.: The Industrial Environment - its Evaluation and Control, Division of Occupational Health, U. S. Public Health Service, Publication No. 614, 2nd Ed., Section B-5, prepared by G.H. Edwards and D.A. Fraser, U. S. Government Printing Office, Washington, D.C. (1965).

Laboratory Exercise - SIZING AIRBORNE DUST

Object

To prepare slides for particle sizing, and to size a dust sample.

Theory

The theory of the microscope can be found in standard handbooks, and the Syllabus (1, 2).

In the evaluation of a dusty atmosphere for a potential health hazard, it is important to know the number and size of the dust particles in addition to the chemical composition of the dust. In this exercise, particles as small as 0.25 micron will be sized. By knowing the number, the size and chemical composition of the air-borne dust, an evaluation of the exposure can be made.

When preparing a slide of dust for particle sizing, it is essential that a representative portion of the sample be used.

Equipment

1. Preparing slides

- a- microscope slides
- b- microscope cover slips
- c- lens tissue
- d- 0.05% methyl methacrylate in chloroform
- e- 50-50% by volume of dimethyl phylate & diethyl oxalate

2. Particle size determination

- a- microscope with 10x ocular and a 97x objective
- b- stage micrometer
- c- filter micrometer
- d- eyepiece graticule
- e- log probability paper

Procedure

The laboratory exercise is divided into two parts: (1) preparation of slides for particle sizing, and (2) particle size determination.

(1)-Each student will clean two microscope slides and two cover slips. Utilizing the following technique (2,3) a section of a dust sample collected on a molecular filter is placed dust slide side up on each slide. Add one or two drops of 0.05% lucite (methyl methacrylate resin) in chloroform to the membrane filter (this step is to fix the dust particles to the filter).

The chloroform is allowed to evaporate and the filter was transferred to another microscopy slide

and mounted dust side down, and cleared with a solution of 50% dimethyl phylate and 50% diethyl oxalate by volume. If necessary a second drop of solution is placed on top of the filter and than covered with a cover slip.

(2)- Particle Size Determination

Obtain Kohler illumination as described in the Bausch & Lomb pamphlet.(1,2). Open the microscope condenser diaphragm and use this lighting system for oil immersion work with the oil objective of the microscope. Lower the microscope condenser slightly and place a drop of immersion oil on its top lens. Place a stage micrometer on the microscope stage with the ruled area centered over the microscope condenser lens. Raise the microscope condenser until the oil on its top lens contacts the lower side of the stage micrometer slide. Place a drop of oil over the rulings on the top of the stage micrometer slide and lower the microscope oil immersion objective lens until it contacts the oil drop, then lower it further with extreme caution until it almost touches the top of the stage micrometer slide. This operation must be done while observing the slide and lens from the side; it must never be done while looking through the microscope. Focus the microscope upward while looking through the eyepiece and searching for the micrometer rulings. Undoubtedly several attempts will be required to locate the rulings.

When the micrometer rulings are brought into focus, align one of the rulings with one of the indices of the filar micrometer or eyepiece graticule, and obtain a ratio of filar units or graticule "L" units to stage micrometer units. (1 mm = 1000 μ). Calculate the number of microns per filar or "L" unit (See section B-7, Vol.I).

Observation Of Dust.

Place a prepared slide on the microscope stage with oil immersion in the same manner as the stage micrometer was placed on the stage. Locate the dust by focusing upward. Determine the size of a number of particles both with a filar eyepiece and an eyepiece graticule.

The procedure for particle size determination using the high dry method requires no oil and utilizes the 43x objective. The same eyepiece and system calibration step are used as above.

Prepared by: Marshall E. LaNier

Calculations

Treatment of data. After 100 particles have been sized complete the data sheet and plot the

data on log probability paper. Determine the median size and the standard geometric deviation of the dust.

References

1. Powell, C.H., and A.D. Hosey, Ed.: The Industrial Environment-its Evaluation and Control, Division of Occupational Health, U.S. Public Health Service, Publication No. 614, 2nd Ed., Section B-5 U.S. Government Printing Office, Washington, D.C. (1965).

Prepared by G.H. Edwards & D.A. Fraser, and Section B-7 prepared by S.B. McKee & R.D. Fulwiler.

2. Fanney, J.H. and C.H. Powell: Unpublished work.

3. Hunt, R.D., Addingley, C.G., and Walton: personal communication.

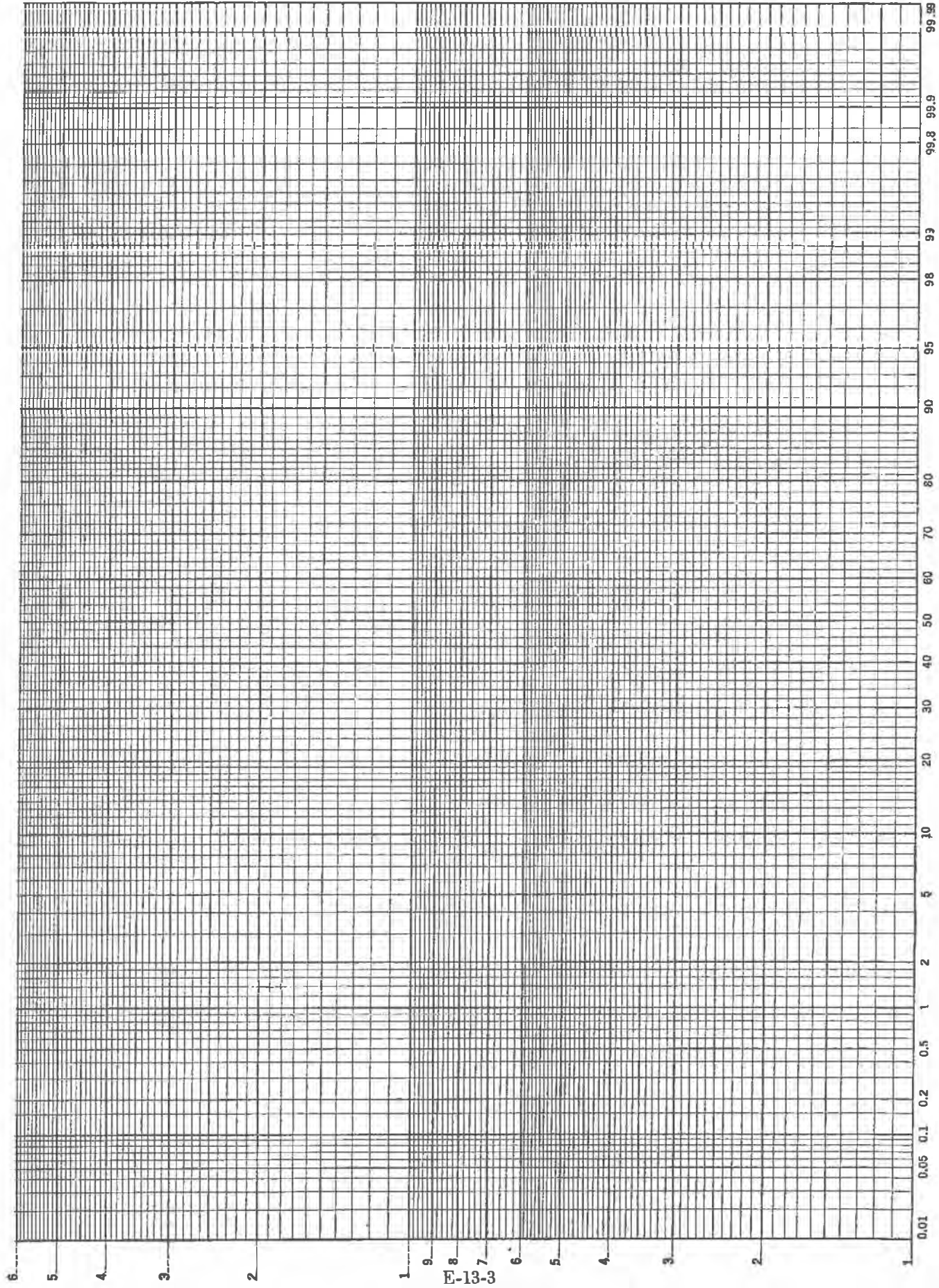

E-13-3

Object

To determine the percent by weight of ~~silica~~ in a sample of mineral dust.

Theory

Hot pyrophosphoric acid dissolves silicate minerals forming water-soluble complexes with both the acidic and basic constituents but has little solvent action on ~~silica~~ particles. The formation of pyrophosphoric acid and the simultaneous dissolution of silicate minerals is accomplished by heating the sample with 85% orthophosphoric acid at an empirically determined rate. After dilution of the ~~silica~~ pyrophosphoric acid with water, the ~~silica~~ is separated by filtration, ignited, weighed and its purity confirmed by volatilization with hydrofluoric acid.

The container for the treatment of the sample is a 250 ml borosilicate glass, Phillips, conical beaker, with spout. Although a considerable amount of glass dissolves from the beakers during the course of the treatment, this in no way interferes with the analysis and is offset by the advantage of conducting the dilution of the treated sample in the same container. Too rapid dehydration of the phosphoric acid and loss of sample by spattering are prevented by covering the beaker with a small funnel, the stem of which is sharply bent to make contact with the side of the beaker. The stem, in addition, is drawn out into a point or beveled to facilitate return of condensed and spattered liquid down the side of the beaker.

As source of heat, a 550 watt, 115 volt, Type RH, Precision heater (Precision Scientific Company) is used. The rheostat of the heater is adjusted to apply 75 volts across the heating

element. The beaker is placed directly on the element of the heater without the use of accessory refractories. Ordinary crucible tongs, cushioned with rubber tubing, are used for handling the hot beakers.

Continuous mechanical swirling of the beaker with a rotator has been found desirable when analyzing large numbers of samples. A retainer for the beaker may be constructed of 0.25-inch pressed asbestos board with a hole slightly larger than the bottom of the beaker and fitted flush with the heating element. About 5 volts less is required when the retainer is used.

The fluoboric acid which is used in the procedure is prepared by diluting commercial 45% fluoboric acid with 2 parts of saturated boric acid solution or by pouring, with continuous stirring, 1 pound of 48% hydrofluoric acid into a mixture of 450 ml of water and 250 grams of boric acid crystals contained in a plastic or hard rubber vessel set in a pan of ice water. Sufficient heat is evolved by the reaction to dissolve all of the boric acid, part of which should recrystallize upon cooling to room temperature. While glass cannot be used for storing the acid, glass apparatus may be used for filtering and measuring the cool acid.

Equipment

1. 1 Phillips beaker, 250 ml., conical borosilicate
2. 1 funnel, 50 mm, with stem bent at 45° angle
3. 1 Precision heater, 550 watt, 115 volt, Type RH
4. Crucible tongs, cushioned with rubber tubing
5. 1 funnel, 70 mm
6. 1 funnel rack
7. 2 wash bottles (distilled water and 1-9 HCl)
8. 1 Griffin beaker, 400 ml
9. 1 graduated cylinder, 10 ml

Revised by: John Crable

10. 1 graduated cylinder, 100 ml
11. 1 pipet or buret, 25 ml
12. 1 platinum crucible
13. 85% phosphoric acid
14. Fluoboric acid
15. 1-1 sulfuric acid
16. 48% hydrofluoric acid
17. Retentive filter paper, 11 cm
(Whatman #42 or equivalent)
18. Paper pulp suspension
19. Concentrated hydrochloric acid
20. Concentrated nitric acid
21. Porcelain crucible

Procedure

A. Sample Preparation. If the sample is oily, it should be treated repeatedly with CP acetone in a tall-form beaker to remove oil and grease. The acetone suspension is stirred and the acetone is decanted between each of several additions of this solvent to the sample. Finally the sample is dried in an oven at 110°C.

Foundry samples and other materials suspected of containing significant quantities of base metals should be leached with an acid mixture to remove the metals. A 0.5 gram sample is placed in a tall form beaker and 10 ml of concentrated hydrochloric acid and 1 ml of concentrated nitric acid are added. Heat until colored fumes are no longer visible. After the solution has cooled add about 100 ml of water, and then filter using Whatman #42 paper and a small amount of paper pulp. After washing with water, place filter paper containing the sample in a porcelain crucible and burn off the paper at 600°C.

B. Analytical Technique. If no preliminary sample preparation is required then proceed to grind the material to pass through a 200 mesh sieve, mix thoroughly, and weigh out 0.5 gram or less on a watch glass or weighting paper and transfer to a 250 ml Phillips beaker by means of a small camel's hair brush. Add 25 ml of 85% orthophosphoric acid

and cover the beaker with a funnel. Place the beaker directly on the element of a Precision heater which has been allowed to preheat for 45 minutes, and begin timing with a stop watch. Swirl the beaker continuously during the heating period with the rotator in order to minimize super-heating and to keep the sample distributed throughout the acid. At the end of 12 minutes remove the beaker from the heater and swirl by hand for 1 minute to dissolve any gelatinous silica which may have deposited on the side of the beaker above the acid. Set the beaker on a cool surface and immediately but cautiously remove the funnel in such a way that adhering liquid runs down the side of the beaker. Allow to cool to room temperature and then wash down the sides of the beaker rapidly with 125 ml of hot (60° to 70°C) water and swirl vigorously until the sirupy phosphoric acid is completely dissolved. Wash down the upper part of the beaker with 10 ml of fluoboric acid and swirl to mix. Then wash down the upper part of the beaker with 25 ml of water and filter through a retentive paper into which has been introduced a small amount of a suspension of paper pulp. Transfer the residue quantitatively to the filter with water and wash six or more times with 1 to 9 hydrochloric acid, followed by one or two washings with water.

Ignite the filter paper in a tared platinum crucible, first at low heat to char the paper, and finally at about 800°C to 900°C until all carbon is burned off. Cool the crucible in a desiccator and weigh. Moisten the residue with 1 to 1 sulfuric acid and add 5 ml or more of 48% hydrofluoric acid. Heat gently until the ~~acid~~ *free carbon* appears completely dissolved, then increase the heat to volatilize the acids. Repeat the treatment of the residue with sulfuric and hydrofluoric acids to ensure complete volatilization of the silica, then ignite at about 800°C for a few minutes, cool, and weigh.

Calculations

Sample _____

Wt. of sample (A)* _____

Wt. of platinum crucible and H₃PO₄ residue

Wt. of platinum crucible No. _____

Wt. of H₃PO₄ residue (B)

Wt. of platinum crucible and HF residue

Wt. of platinum crucible No. _____

Wt. of HF residue (C)

$\frac{B \times 100}{A} = \frac{\quad \times 100}{\quad} =$ % H₃PO₄ residue (D) ‡

$\frac{C \times 100}{A} = \frac{\quad \times 100}{\quad} =$ % HF residue (E)

$D - E =$ % ~~FREE~~ *FREE SILICA*

* Report weights to 0.1 mg

‡ Report results to 2 decimal places

Reference

1. Talvitie, N. A., "Determination of Quartz in Presence of Silicates Using Phosphoric Acid," Anal. Chem. 23, 623 (1951).

Add sufficient 4% solution of sodium diethyldithiocarbamate to combine with metallic impurities. After a few minutes, extract with chloroform until the excess reagent is removed. The absence of a yellow color in the chloroform when a portion of the extract is shaken with a dilute copper solution indicates when this point has been reached. Add distilled hydrochloric acid until the indicator turns pink, and adjust the volume to 100 ml with double-distilled water.

h. Potassium cyanide - prepare a practically saturated solution containing 50 grams of potassium cyanide. (A weaker solution will not have the proper pH). Extract the lead with dithizone in chloroform (about 30 mg/l) until a green extract is obtained, then extract the excess dithizone with chloroform. Dilute with double-distilled water to 500 ml.

i. Ammonia-cyanide mixture - mix 200 ml purified 10% potassium cyanide with 150 ml distilled ammonium hydroxide (specific gravity 0.9) and make to 1 liter with double-distilled water. If the specific gravity of the distilled ammonia is not 0.9, the equivalent volume should be computed from table of specific gravity vs. percent ammonia, and this amount used instead (Sp. Gr. 0.9 = 28.4% NH₃).

j. 1:99 Nitric acid - dilute 10 ml redistilled nitric acid to 1 liter with double-distilled water.

k. Standard Lead Solution - dissolve 1.5984 g pure lead nitrate in 1 liter of 1:99 nitric acid to produce a stock solution containing 1 mg Pb per ml. Prepare working solutions by diluting with 1% nitric acid to a strength of 2 micrograms Pb per ml.

l. Indicator solutions - 0.1% Phenol red, m-cresol purple.

Procedure

This exercise will be conducted over the course of two afternoons. A set of 50 ml urine samples containing known quantities of added lead will be pro-

vided in 125 ml Phillips beakers. To save time, these samples will have been evaporated to dryness on a steam bath after the addition of a small amount of nitric acid.

Select one sample, noting the number. During the first afternoon complete the ashing of this sample by following the directions given in the second paragraph of the method (Appendix). Several volunteers will also ash reagent blanks which will be carried subsequently through the entire procedure. When time permits, wash 3 separatory funnels with concentrated nitric acid, tap and distilled water as will be demonstrated. (Two additional clean funnels will be required for those running blanks). Initial these funnels for your use on the following afternoon.

During the second afternoon dissolve the ashed sample, according to the instructions in the method (Appendix), with nitric acid and distilled water. As a half hour or more of heating may be required for this operation, it should be started at the beginning of the period. This time can then also be used for carrying out the free silica determination. The remainder of the analysis will then be completed. Please do not contaminate the reagents by careless use of the pipets. DANGER! A rubber bulb will be used with the pipets. Do not pipet potassium cyanide by mouth as it is highly poisonous! Note that many of the reagents are provided in automatic burets for greater convenience and minimal contamination. This analysis will require two of the separatory funnels cleaned on the first day.

Standardization (See Standardization Section of Appendix).

The third separatory funnel will be used for preparing a lead standard, from a standard lead solution provided in a buret. The first two students will prepare zero standards which will be used as the photometer references. Each following student will then select one

of the lead values indicated on a sheet near the buret, noting his initials after the selected value. Add the indicated quantity of lead and apply the procedure starting at the appropriate step indicated in the fourth paragraph of the method (Appendix). The results will then be plotted to provide the standard curve, at the conclusion of the exercise.

Calculations

Determine from the standard curve the number of micrograms of lead required to produce an optical absorbance of exactly one. Multiply by this factor

the experimentally determined absorbance values of the sample and of the blank to convert to micrograms of lead. The difference between these two values, divided by the volume of urine in milliliters, gives the milligrams of lead per liter of urine.

The use of a standardization factor as given above eliminates the necessity of graphically determining each lead quantity, and gives more accurate results with less effort. This method is possible because the relationship between absorbance and micrograms of lead is linear.

APPENDIX

METHODS FOR DETERMINING LEAD IN AIR AND IN BIOLOGICAL MATERIALS U. S. Public Health Service

Procedure for Urine*

Collection of a 24-hour sample in a 2 liter glass-stoppered bottle is recommended. Measure 50 ml of the fresh urine sample into a 250 ml Phillips beaker. If the urine is over a day old or contains a precipitate, empty the sample bottle into a stoppered graduated cylinder, dissolve the precipitate adhering to the glass, and rinse out with two small portions of nitric acid, followed by one of double-distilled water. Mix the urine and rinsings cautiously (carbon dioxide is generated) and take a volume of the mixture equivalent to 50 ml of urine (calculated from the original volume of the sample and the volume of rinsings added).

Evaporate to dryness overnight on the steam bath. Add 1-2 ml of nitric acid and heat on the hot plate at a moderate heat for a few moments, then

swirl the beaker to dissolve and mix the residue. Continue heating until the reaction ends and all the water is driven off. Cover the beaker with a watch glass for the remainder of the ashing. Repeat the treatments with nitric acid, gradually decreasing the portions to 0.5 ml and gradually increasing the heat of the hot plate, charring as much as possible and cooling the beaker before each addition. Overheating causes violent flashing and should be avoided to prevent loss of sample. After 3 or 4 portions of nitric acid have been added, the hot plate should be at full heat (400°C). The most powerful ashing occurs when the dry salts decompose giving off red fumes of nitrogen dioxide. Following the production of a white ash, add a few more portions of nitric acid to ensure complete ashing. Less than 10 ml of nitric acid suffices in most cases for the whole process.

*Suitable unless the presence of bismuth in the urine is definitely expected. (See Elkins, H.B., and Ruotolo, B.P.W., Amer. Ind. Hyg. Assoc. Quarterly 14, 111-112 (June 1953) for a discussion of the occurrence of bismuth).

To the ashed sample add 2 ml nitric acid and 10 ml of double-distilled water, and heat gently until a clear solution is obtained. Cool to room temperature and add 1 ml 20% hydroxylamine hydrochloride, 10 ml 25% sodium citrate,

1 drop phenol red indicator, and titrate to a strong red color (pH 9-10) with redistilled ammonium hydroxide. (Phenol red has a weak orange-red color in strong acid, yellow in weak acid, and a red color in alkaline solution. Do not mistake the first color for the endpoint). Transfer with double-distilled water to a 125 ml Squibb separatory funnel containing 5 ml 10% potassium cyanide. Shake 1-2 minutes with 5 ml portions of dithizone (16 mg/1 in chloroform) until a green extract indicates that all the lead has been removed (generally two times). The addition of the chloroform initiates precipitation of calcium and magnesium phosphates; hence, once extraction is begun it should be completed without delay. Combine the extracts in a second funnel containing 30 ml of 1:99 nitric acid.

The extracted lead is then stripped from the chloroform layer by shaking the second funnel for two minutes, and the chloroform is discarded. (Note: Standards are started at this point.) The aqueous layer is then washed by shaking with 5 ml chloroform, which is discarded with as close a separation as possible. The last drop of chloroform floating on the surface is evaporated by blowing air gently into the funnel.

Add 6.0 ml ammonia-cyanide mixture, exactly 15 ml standard dithizone (8 mg/1 in chloroform), and shake for two minutes. Insert a pledget of cotton* into the stem of the funnel and drain the chloroform layer into a dry photometer tube. (A set of matched test tubes, 22 x 175 mm may be used). Inspect for water droplets in the light path - if present, carefully decant the tube into

"*Test prior to use by moistening a small plug of cotton with standard dithizone. If it turns pink within a few minutes, purification is desirable. Wash the entire batch of cotton in a Buchner funnel, first with extraction dithizone, then with chloroform until white. Air dry under a dust cover."

another dry photometer tube, leaving the water behind. Read the absorbance at 510 millimicrons using the blank as a reference. Report lead content as milligrams per liter of urine. (Normal range 0.01-0.08).

Standardization: The standard dithizone should be aged a day or two before using or standardizing and should be restandardized every month or two. Prepare a series of funnels containing graduated amounts of lead up to 25 micrograms in exactly 30 ml of 1:99 nitric acid. The method is applied to these standard samples starting at the appropriate step in the fourth paragraph. The zero standard is used as the photometer reference, and the absorbance values are plotted against micrograms of lead to obtain the standard curve.

Procedure for Blood

A 5-10 ml sample in a vacutainer or test tube is satisfactory for analysis. Weigh the entire sample into a 125 ml borosilicate Phillips beaker. Add 1 ml nitric acid and evaporate to dryness on the hotplate at a low heat. Add a single 2 ml portion of potassium sulfate ashing-aid reagent (25 grams K_2SO_4 dissolved in concentrated nitric acid to make 100 ml) to prevent possible losses of lead on strong heating. Continue the ashing in the manner described for urine. Final solution of blood ash takes more time because of the iron content. The analysis follows the same procedure as for urine, except that the quantity of sodium citrate may be reduced to 4 ml. Report lead content as milligrams per 100 grams of blood. (Normal range 0.01-0.08).

Procedure for Air Samples

Electrostatic precipitator tubes are conveniently washed out with ethanol using a special policeman made with a rubber disc cut to fit like a piston. Contents are washed using a short stem funnel into a 250 ml borosilicate Phillips beaker and evaporated to dryness.

Impinger samples may be transferred to the same type of beaker and evaporated.

Ashing is performed by adding 1-2 ml portions of nitric acid at a moderate heat. The ashing may be speeded in the LATER stages by adding a few drops of perchloric acid WITH the nitric acid. (CAUTION: Explosive with large amounts of organic matter in absence of nitric acid!) In the event that the ash content of the sample is very low, the addition of 1 ml of 10% sodium sulfate or bisulfate at the beginning will prevent loss of lead on the glass; however, this should not be used if the amount of lead is large enough to precipitate. The ash is then dissolved in 1-2 ml nitric acid and diluted to a convenient volume (100 ml) in a volumetric flask.

An aliquot is then analyzed by the procedure for blood. The amount of lead may be estimated by the number of 5 ml

portions of dithizone required for the preliminary extraction, each portion being equivalent to about 20 micrograms of lead when a saturated red color is obtained. A convenient amount to be taken for analysis should be such that no more than 10 portions are needed.

If the estimated amount of lead exceeds the range of the method (25 micrograms), the 1:99 nitric acid containing the stripped lead (at the point indicated for standards to be started) is then aliquoted, and this aliquot is made up to 30 ml with additional acid in another funnel. The remainder of the procedure is then continued on the second aliquot.

When reporting the results, allowance is made for the two aliquots. It is most convenient to aliquot the blank in the same manner to simplify the correction.

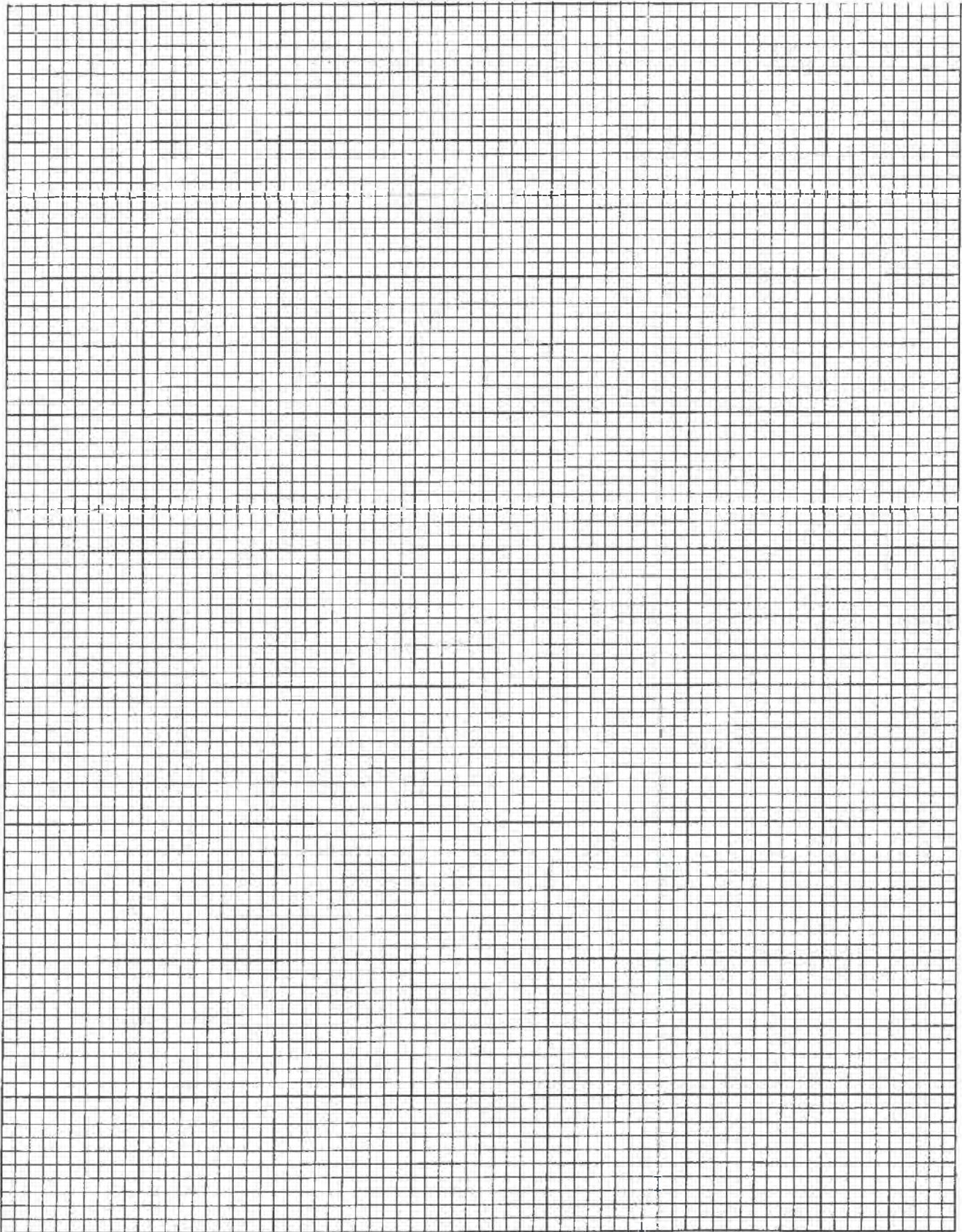

Laboratory Exercise - POLAROGRAPHIC DETERMINATION OF LEAD, CADMIUM AND ZINC

Object

To demonstrate the polarographic determination of lead, cadmium and zinc in an atmospheric dust or fume sample.

Theory

Lead, cadmium and zinc are frequently associated with one another in the industrial environment. Atmospheric dust and fume samples, settled dusts, ores and other bulk materials can be analyzed polarographically, after appropriate chemical treatment, to provide quantitative data on these three elements. By the use of 0.2 M potassium chloride as supporting electrolytes, their half-wave potentials are separated sufficiently to permit accurate analysis.

Equipment and Reagents

1. Recording polarograph, including dropping mercury electrode assembly
2. Electrolysis vessel
3. Constant temperature bath
4. Potassium chloride solution, 0.2 M
5. Potassium chloride solution, 2.0 M
6. Nitric acid, concentrated
7. Perchloric acid, 70%
8. Gelatin solution, aqueous, 1%
9. Nitrogen gas, oxygen free
10. Hydroxylamine hydrochloride
11. Hydrochloric acid, 1:3
12. Potassium hydroxide, 25%

Procedure

Electrostatic precipitator tube samples. Transfer the sample to a 125 ml Phillips beaker (borosilicate) using a rubber policeman with alcohol. Evaporate to dryness on a steam bath. Add 2 ml nitric acid, wetting the sample thoroughly. Add 6 drops perchloric acid and swirl to mix. Evaporate to dryness on a hotplate at 350 - 400°C. Repeat the acid treatment to obtain complete digestion. Cool and add 10 ml of the 0.2 M potassium chloride solution.

Loosen solids with the policeman and rinse policeman and beaker walls with 2-3 ml of the 0.2 M potassium chloride solution from a wash bottle. Cover with a watch glass and boil 2 - 3 minutes. Filter the solution through Whatman #42 paper and wash the filter with 0.2 M potassium chloride; collect the filtrate and washings in a 25 ml volumetric flask. Dilute to volume with the same potassium chloride reagent, which serves as the supporting electrolyte in this method.

Place a sufficient quantity of 1% gelatin solution in the electrolysis vessel to yield a 0.01% final solution. Transfer the desired aliquot to this vessel and remove dissolved oxygen by passing nitrogen through the solution for 10 minutes. Record the polarogram in the 0.0 to -1.5 volt region.

Bulk sample materials. Grind the material to pass through a 20 mesh sieve, mix thoroughly, weigh accurately 0.5 gram on a watch glass or glazed paper and transfer to a 125 ml Phillips beaker. Add 25 ml of 1:3 hydrochloric acid and boil for 5 minutes to remove hydrogen sulfide. Add 2 ml of nitric acid and evaporate to dryness. Cool, add 20 ml of 1:6 hydrochloric acid and approximately 0.25 gram of hydroxylamine hydrochloride and boil to reduce iron and copper. Filter through Whatman #42 paper and wash the filter with distilled water; collect the filtrate and washings in a 100 ml volumetric flask. Add 10 ml of 2.0 M potassium chloride solution and sufficient potassium hydroxide to make the solution weakly acidic with no precipitation occurring. Dilute to volume.

To 1 ml of the sample solution add 9 ml of 0.2 M potassium chloride and 0.1 ml of 1% gelatin solution. Pass nitrogen through the solution for 10 minutes. Prepare a polarogram in the 0.0 to -1.5 volt region.

Determine the diffusion current for each step of the polarogram by measuring the step height in millimeters and multiply this value by the microampere per millimeter factor for the particular sensitivity setting employed. Estimate the amount of each element from the standard curves.

Calculations

Calculate the quantity of each element in the total sample by multiplying the above values by the aliquot reciprocal values.

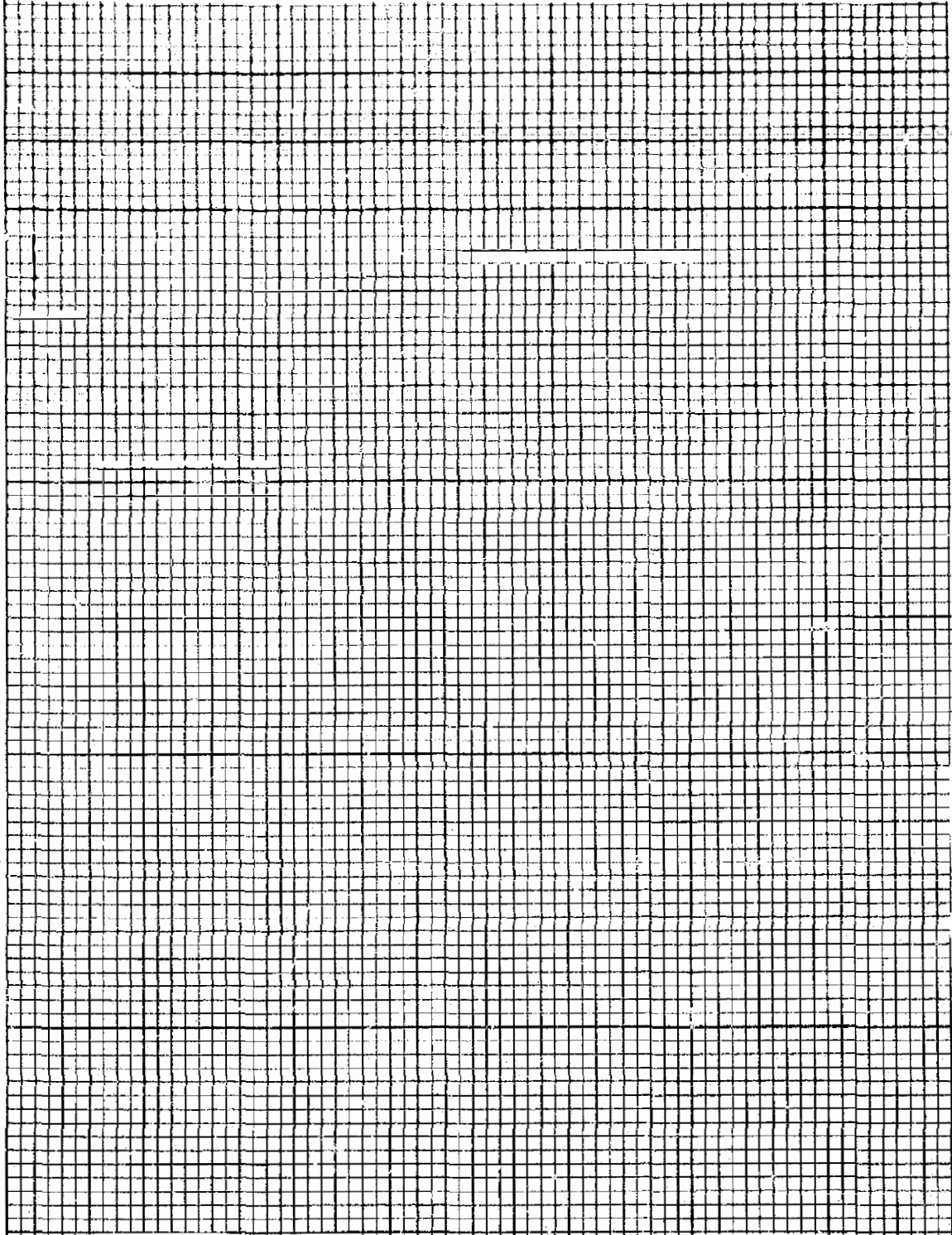

Laboratory Exercise - DETERMINATION OF APPROXIMATE COMPOSITION OF SOLVENTS.

A number of individual experiments are given below. The experiments need not be carried out in any special order.

Test 1. Preliminary Miscibility Tests

Object

To determine the approximate composition of a solvent mixture.

Theory

In order for solubility to occur the intermolecular forces between the solvent and the solute must be greater than the intermolecular forces between the solute molecules. The nature of these forces depends upon the compounds involved and are influenced by various functional groups.

Equipment and Reagents

1. Graduated cylinders, glass stoppered, 25 ml
2. Pipets
3. Hydrochloric acid, concentrated (or 4:1 sulfuric acid)
4. Dimethyl sulfate

Procedure

1. Miscibility in water and specific gravity: Pipet 10 ml of solvent into a dry, weighed graduate. Calculate the specific gravity from the gain in weight. Add 10 ml H₂O and mix gently. Complete miscibility excludes saturated aliphatic hydrocarbons, aromatic hydrocarbons, halogenated derivatives of these hydrocarbons, organic acids, weakly acidic compounds such as phenols, enols, primary and secondary nitro compounds, oximes, amino acids and neutral compounds.
2. Miscibility in concentrated hydrochloric acid (or 4:1 sulfuric acid): Add 10 ml of solvent to 10 ml of acid contained in another clean cylinder. Invert several times, let settle and note volumes of layers. Alcohols, esters, aldehydes, ketones and unsaturated compounds, anhydrides, ethers and quinones dissolve in these acids. Inert compounds, such as saturated aliphatic and aromatic hydrocarbons and their halogenated derivatives do not dissolve in these acids.

3. Solubility in dimethyl sulfate (CAUTION - KEEP REAGENT OFF SKIN. USE RUBBER BULB FOR PIPETING.): Pipet 10 ml of the sample into a stoppered cylinder containing 10 ml of dimethyl sulfate. Invert several times and observe volume change of oil layer to estimate approximate aromatic content. If aromatics exceed 25%, accurately dilute the sample with petroleum naphtha and repeat the test as, otherwise, erroneously high results may be obtained.

Calculations

Percent miscibility equals $100 \times (\text{original solvent volume} - \text{final solvent volume}) / \text{original solvent volume}$.

Test 2. Beilstein Test for Halogenated Hydrocarbons

Object

To conduct a qualitative test for halogenated hydrocarbons.

Theory

The action of halogenated hydrocarbons on copper wire in a flame yields copper halide which is volatile and produces a green flame.

Equipment

A small loop of copper wire, preferably supported in a glass handle set into a stopper. This assembly can be protected from contamination by keeping in a test tube when not in use.

Procedure

Make a small loop of copper wire and heat in the edge of a gas flame until flame is no longer colored. Caution: Do not melt the wire in the hotter portions of the flame. Cool wire and dip loop in a little of original solvent mixture and then heat in edge of flame. Green flame indicates a halogen.

Confirmatory Test - AgNO₃

About 2 ml of the original solvent or separated fraction is acidified with dilute HNO₃ and boiled gently for a few minutes to expel any HCN or H₂S. Add a few drops of AgNO₃. A heavy precipitate indicates a halogen.

Revised by: Robert L. Larkin

Test 3. Optical Properties of Hydrocarbon Mixtures

Object

To determine aromatic content of a hydrocarbon mixture by optical measurements.

Theory

The index of refraction and dispersion of aromatics are generally much higher than those of paraffin hydrocarbons. The relationship between the composition of mixtures of such solvents and these properties will be determined.

Equipment and Reagents

1. Abbe refractometer
2. Pure benzene

3. Pure isooctane
4. Standard 20%, 40%, 60%, and 80% mixtures (by volume), and unknown mixtures of benzene and isooctane.

Procedure

Determine the optical index of refraction and dispersion of known solvents and the unknown samples. Compute the specific dispersion using the nomograph provided with the refractometer and the density values given for the samples.

Plot standard curves relating index of refraction and specific dispersion to volume percent composition. Compare experimental values with the following literature values for the pure substances.

Values at 25°C. from National Bureau of Standards

<u>Substance</u>	<u>Index of refraction (n_D)</u>	<u>Specific Dispersion</u> $10^4(n_F - n_C) / d$
Isooctane	1.38898	100.5
Benzene	1.49790	189.6

Compute the composition of the unknown samples on the basis of

- (a) index of refraction and
- (b) specific dispersion using these curves.

Test 4. Test for Methyl Ketones

Object

To determine the presence of methyl ketones (RCOCH_3).

Theory

The mechanism of this color reaction is unknown.

Equipment and Reagents

1. Porcelain crucibles
2. Acetone
3. Unknown solvent
4. 5% sodium nitroprusside
5. 30% sodium hydroxide.

Procedure

Add a drop of 5% sodium nitroprusside and a drop of 30% sodium hydroxide to a drop of aqueous or alcoholic test solution in a crucible. After a short time, when a slight color usually develops, add 1 or 2 drops of glacial acetic acid. A red or blue color indicates the presence of a methyl ketone.

Test 5. Test for Esters

Object

To conduct a qualitative test for esters (RCOOR').

Theory

Esters of carboxylic acids can be converted to hydroxamic acids on treatment with hydroxylamine hydrochloride in the presence of alkali: $\text{RCOOR}' + \text{NH}_2\text{OH} \rightarrow \text{RCO}(\text{NHOH}) + \text{R}'\text{OH}$. These acids form colored, inner complex, trivalent iron salts with ferric chloride.

Equipment and Reagents

1. Saturated alcoholic solution of hydroxylamine hydrochloride
2. Saturated alcoholic solution of potassium hydroxide
3. Amyl acetate test solution
4. 0.5 N hydrochloric acid
5. 1% ferric chloride
6. Crucibles
7. Burner

Procedure

To a drop of the dry test solution in a crucible, add one drop of the hydroxylamine hydrochloride

solution and one drop of the potassium hydroxide solution. Heat over a microflame until the reaction begins, observed as a slight bubbling.

After cooling, acidify with 0.5N hydrochloric acid and add a drop of 1% ferric chloride. An intense violet color indicates an ester.

Test 6. Determination of Methanol

Object

To determine the presence of methanol in solvent mixtures.

Theory

This test is based on the fact that methyl alcohol is readily oxidizable to formaldehyde upon the addition of potassium permanganate in the presence of phosphoric acid and the formaldehyde which is formed then reacts with chromatropic acid (1,8, -dihydroxy naphthalene - 3,6, -disulfonic acid) in the presence of sulfuric acid forming a violet color. The test may be used to detect the presence of methanol in ethanol mixtures and is specific for methanol. The limit of detection is 3.5 micrograms.

Equipment and Reagents

1. Dissolve 50 mg of chromatographic acid or its sodium salt in 100 ml of 75% sulfuric and heat in a water bath for 10 minutes at 60°C.
2. Test tubes
3. 5% phosphoric acid
4. 5% potassium permanganate
5. 5% sodium bisulfite

Procedure

To one drop of the sample in a test tube add one drop of 5% potassium permanganate solution. Mix, allow to stand for one minute, and add 5% sodium bisulfite dropwise until the permanganate color is discharged. If any brown color is visible add an additional drop or two of phosphoric acid and more of the sodium bisulfite solution. When the solution is completely colorless add 5 ml of freshly prepared chromatropic acid solution. Shake well and heat the test tube for 10 minutes at 60°C. A violet color that deepens on cooling shows the presence of methanol in the sample.

Test 7. Fractionation of Hydrocarbon-Chlorinated Hydrocarbon Mixtures

Object

To determine the composition of a mixture of hydrocarbons and chlorinated hydrocarbons by fractional distillation, density and refractive index measurements.

Theory

By means of a fractionating column the various components of a mixture may be separated according to their differences in boiling points. A step-type plot is obtained when the top column temperature is plotted against the volume distilled. If the distillate corresponding to the horizontal portion of each step is collected in a separate container the pure components may be identified by boiling point, index of refraction, specific gravity and dispersion measurements, or by other confirmatory tests.

Equipment and Reagents

1. Fractionating column, which will be demonstrated only.
2. Graduated cylinders, containing various cuts of distillate, provided with the boiling point curve and specific gravity data.
3. Abbe refractometer.

Procedure

Because the fractionation operation is time consuming, this portion of the analysis will be carried on as a demonstration. The final results will be available in the form of a distillation plot together with cylinders containing the various cuts, with the weights, volumes, index of refraction and optical dispersion for each cut.

Calculations

Identify the composition of each cut by comparing the known properties with those given in an available table of physical constants. If the cut appears to contain more than one component, the approximate composition may be computed by interpolation. Calculate the composition of the solvent on a weight basis, using the weights given in the distillation data.

Introduction

The West and Gaeke method is applicable to determination of sulfur dioxide in outside ambient air in the concentration range from about 0.005 to 5 parts per million (ppm). Sulfur dioxide in the air sample is absorbed in 0.1 M sodium tetrachloromercurate.¹ Nonvolatile dichlorosulfite ion is formed in this process. Addition of acid-bleached pararosaniline and formaldehyde to the complex ion produces red-purple pararosaniline methylsulfonic acid, which is determined spectrophotometrically.² The system obeys Beer's Law up to about 10 μ l of sulfur dioxide per 10 ml of absorbing solution. This method is more sensitive than the hydrogen peroxide method and is not subject to interference from other acidic or basic gases or solids such as SO₃, H₂SO₄, NH₃, or CaO; however, the analysis should be completed within 1 week after sample collection, and the concentrations of ozone and nitrogen dioxide should be less than that of the sulfur dioxide.

Reagents

All chemicals used must be ACS analytical-reagent grade.

Absorbing reagent, 0.1 M sodium tetrachloromercurate. Dissolve 27.2 g (0.1 mole) mercuric chloride and 11.7 g (0.2 mole) sodium chloride in 1 liter of distilled water. (CAUTION: Highly poisonous. If spilled on skin, flush off with water immediately.)

Pararosaniline hydrochloride (0.04%), acid bleached. Dissolve 0.20 g of pararosaniline hydrochloride in 100 ml of distilled water and filter after 48 hours. This solution is stable for at least 3 months if stored in the dark and kept cool. The pararosaniline hydrochloride used should have an assay of better than 95% and an absorbance maximum at 543 or 544 m μ . Pipette 20 ml of this into a 100-ml volumetric flask. Add 6 ml of concentrated HCl. Allow to stand 5 minutes, then dilute to mark with distilled water. This solution should be pale yellow with a greenish tint. It can be stored at room

¹ Prepared by Seymour Hochheiser, Technical Assistance Branch, Division of Air Pollution, Public Health Service. Approved by the Interbranch Chemical Advisory Committee, November 1963.

Reprinted From - Selected Methods for the Measurement of Air Pollutants, Division of Air Pollution U.S. Public Health Service, Publication NO. 999-AP-11, May 1965.

temperature in an amber bottle for a week or for about 2 weeks if refrigerated.

Formaldehyde, 0.2%. Dilute 5 ml of 40% formaldehyde to 1,000 ml with distilled water. Prepare weekly.

Standard sulfite solution. Dissolve 640 mg sodium metabisulfite (assay 65.5% as SO₂) in 1.0 liter of water. This yields a solution of approximately 0.40 mg/ml as SO₂. The solution should be standardized by titration with standard 0.01 N I₂ by using starch as indicator, and adjusted to 0.0123 N. Then 1 ml = 150 μ l SO₂ (25°C, 760 mm Hg). Prepare and standardize freshly.

Starch solution (iodine indicator), 0.25%. Make a thin paste of 1.25 g of soluble starch in cold water and pour into 500 ml of boiling water while stirring. Boil for a few minutes. Store in a glass stoppered bottle.

Standard iodine solution, 0.01 N. Dissolve 12.69 g of resublimed iodine in 25 ml of a solution containing 15 g of iodate-free KI; dilute to the 1,000-ml mark in a volumetric flask. Pipet exactly 100 ml of this 0.1 N solution and dilute to 1,000 ml in a volumetric flask with 1.5% KI. This solution can be used as a primary standard if the weighing is carefully done or it can be checked against a standard thiosulfate solution. This solution should be stored in an amber bottle, refrigerated, and then standardized on the day of use.

Apparatus

Absorber. An all-glass midget impinger or other collection device should be capable of removing SO₂ from an air sample by using 10 ml of absorbing reagent. (Among the suppliers of midget impingers are Ace Glass Company and Gelman Instrument Company).

Air pump. The air pump should be capable of drawing 2.5 liters per minute through the sampling assembly.

Air-metering and flow control devices. These devices ought to be capable of controlling and measuring flows with an accuracy of \pm 2 percent. The flow meter should be calibrated for variations in reading with temperature and pressure of the air-stream so that the appropriate corrections can be applied.

Thermometer (or other temperature-measuring device). This device should have an accuracy of \pm 2°C.

Mercury manometer (or other vacuum-measuring

device). This device should have an accuracy of 0.2 in. Hg.

Spectrophotometer or colorimeter. This instrument should be capable of measuring color intensity at 560 $m\mu$, in 1-cm absorbance cells or larger.

Analytical Procedure

Collection of samples. Set up a sampling train consisting of, in order, absorber, trap to protect flow device, flow meter, flow control device, temperature and vacuum gauge, and air pump. Shield the absorbing reagent from direct sunlight during and after sampling by covering the absorber with a suitable wrapping such as aluminum foil to prevent deterioration of sample. All probes and tubing upstream from the bubbler should be pyrex glass, stainless steel, or teflon. Butt-to-butt connections may be made with tygon tubing. The downstream metering device can be empirically corrected to atmospheric conditions by conducting a dummy run with an upstream flow meter in line that is open to the atmosphere.

Pipet exactly 10 ml of absorbing reagent into the absorber. Aspirate the air sample through the absorber at a rate of 0.2 to 2.5 liters per minute (depending upon the concentration of sulfur dioxide in the atmosphere and the sampling time desired). The sampling time may vary from a few minutes to 24 hours. For 24-hour sampling, the absorber selected should be capable of containing 20 ml or more of absorbing reagent. For best results, the sampling time and rate should be chosen to provide a concentration of approximately 2 to 4 μl of SO_2 in 10 ml of the absorbing reagent. The dichlorosulfite-mercurate formed may be stored for 3 days with only a slight decrease in strength (about 1 % per day). If samples are stored for longer periods, a correction factor should be applied.^{3,4} The sample may be stored in the collection device or transferred to a stoppered glass or polyethylene container.

Analysis. If a mercury precipitate is formed owing to the presence in the air sample of inorganic sulfides, thiols, or thiosulfates, it may be removed by filtration or centrifugation. To the clear sample, adjusted to 10 ml with distilled water to compensate for evaporative losses, add 1.0 ml of acid-bleached pararosaniline solution and 1.0 ml of the 0.2% formaldehyde solution and mix. In this analysis, reagent addition and spectrophotometric analysis can be automated.⁵

Treat a 10-ml portion of unexposed sodium tetrachloromercurate solution in the same manner for use as the blank. If the collecting reagent remains exposed to the atmosphere during the interval be-

tween sampling and analysis, the blank should be exposed in the same manner.

Allow 20 minutes for maximum color development and read the absorbance at 560 $m\mu$ in a spectrophotometer using the blank as the reference.

Calculations. Convert the volume of air sampled to the volume at standard conditions of 25°C, 29.97 in. Hg:

$$V_s = V \times \frac{(P - P_m)}{29.97} \times \frac{298.2}{(t + 273.2)} \quad (1)$$

V_s = volume of air in liters at standard conditions

V = volume of air in liters as measured by the meter

P = barometric pressure in inches of mercury

P_m = suction at meter in inches of mercury

t = temperature of sample air in degrees centigrade

Ordinarily the correction for pressure is slight and may be neglected.

Compute the microliters of sulfur dioxide in the sample by multiplying the absorbance by the slope of the calibration plot. Then the concentration is:

$$\text{ppm SO}_2 \text{ by volume} = \frac{\mu\text{l SO}_2}{V_s} \quad (2)$$

Preparation of Calibration Curve

Pipet exactly 2 ml of standard sulfite solution into 100-ml volumetric flask and dilute to mark with absorbing reagent. This final solution contains 3.0 μl SO_2 per ml.

Add accurately portions of the dilute standard sulfite solution of 0.5, 1.0, 1.5, and 2.0 ml to a series of 10-ml glass stoppered, graduated cylinders and dilute to the marks with absorbing reagent. Continue with the analysis procedure given above.

Plot the absorbance (optical density) as the abscissa against the μl of SO_2 per 10 ml of absorbing solution on rectangular coordinate paper. Compute slope of straight line best fitting the data.

Discussion of Procedure

The error for the combined sampling and analytical technique is $\pm 10\%$ in the concentration range below 0.10 ppm with increasing accuracy with concentration in the range 0.1 to 1 ppm. The measurements should be reported to the nearest 0.005 ppm

at concentrations below 0.15 ppm and to the nearest 0.01 ppm above 0.15 ppm.

O₃ and NO₂ interfere if present in the air sample at concentrations greater than that of SO₂.⁶ Interference of NO₂ is eliminated by including 0.06% sulfamic acid in the absorbing reagent.⁷ This may, however, result in losses of SO₂ during sampling and during storage of the sample for more than 48 hours after collection. NO₂ interference may also be eliminated by adding 0-toluidine or sulfamic acid subsequent to sample collection.^{8,9}

Heavy metals, especially iron salts, interfere by oxidizing dichlorosulfitomercurate during sample collection. This interference is eliminated by including ethylenediaminetetraacetic acid in the absorbing reagent. Sulfuric acid or sulfate do not interfere. There is no experimental evidence to indicate that SO₃ interferes; it probably hydrolyzes preferentially in the absorbing reagent to form H₂SO₄, rather than combines with sodium tetrachloromer-

curate to form the dichlorodisulfitomercurate complex ion. If the latter reaction prevails, the presence of SO₃ will result in a positive interference. If relatively large amounts of solid material are present, a filter may be used advantageously upstream; however, a loss of SO₂ may occur.

The color produced is independent of temperature in the range 11 to 30°C and is stable for 3 hours.¹

Much difficulty with the method has been caused by the use of impure pararosaniline hydrochloride.¹⁰ A commercial brand is now available that is specially selected for this procedure (Fisher Scientific Company, catalog No. P-389). The purity of the reagent may be estimated by comparing the slope of the calibration plot with the value 0.15 absorbance unit per μl (obtained with 1-cm cells in a Cary spectrophotometer), which corresponds to a molar absorptivity of 36,700.

References

1. West, P.W., Gaeke, G.C. Fixation of Sulfur Dioxide as Disulfitomercurate (II), Subsequent Colorimetric Estimation, *Anal. Chem.* 28:1916. 1956
2. Nauman, R.V., West, P.W., Tron, F., Gaeke, G.C., A Spectrophotometric Study of the Schiff Reaction as Applied to the Quantitative Determination of Sulfur Dioxide, *Anal. Chem.* 32:1307. 1960
3. Perry, W.H., Tabor, E.C., National Air Sampling Network Measurement of SO₂ and NO₂, *Arch. Environmental Health.* 4:44. 1962.
4. McCaldin, R.O., Hendrickson, E.R., Use of a Gas Chamber for Testing Air Samplers, *J. Amer. Ind. Hyg. Assoc.* 20:509. 1959.
5. Welch, A.F., Terry, J.P., Developments in the Measurement of Atmospheric Sulfur Dioxide, *J. Amer. Ind. Hyg. Assoc.* 21:316. 1960.
6. Terraglio, F.P., Manganelli, R.M., Laboratory Evaluation of SO₂ Methods, *Anal. Chem.* 34:675. 1962.
7. West, P.W., Ordoveza, F., Elimination of Nitrogen Dioxide Interference in the Determination of Sulfur Dioxide, *Anal. Chem.* 34:1324. 1962.
8. Zurlo, N., Griffini, A.M., Measurement of Sulfur Dioxide Content of the Air in the Presence of Nitrogen and Heavy Metals, *Med. d. Lavoro.* 5:330. 1962.
9. Lodge, J.P., Pate, J.B., Swanson, G.A., Ammons, B.E., Nitrogen Dioxide Interference in the Colorimetric Determination of Atmospheric Sulfur Dioxide. Presented at 148th Nat. Meeting, Amer. Chem. Soc. Chicago. August 30 - September 4, 1964.
10. Pate, J.B., Lodge, J.P., Wartburg, A.F., Effect of Pararosaniline in the Trace Determination of Sulfur Dioxide, *Anal. Chem.* 34:1660. 1962.

Laboratory Exercise - SAMPLING AND DETERMINATION OF METHYL KETONES.

Object

1. To demonstrate a simple method for laboratory preparation of known concentrations of vapor in air.
2. To demonstrate and compare two common methods of collection of vapors.
 - a. Fritted bubbler
 - b. Silica gel tube
3. To demonstrate a general method for analysis of methyl ketones.

Theory

A known concentration of acetone in air is ob-



A measured amount of standard iodine is added and the excess is back titrated with standard sodium thiosulfate solution, using starch as indicator. The amount of iodine consumed by the iodoform reaction is thus obtained by difference. This value is used to calculate the quantity of acetone in the sample solution and the concentration of this methyl ketone in the air sample.

Equipment and Reagents

1. 2 Calibrated carboys connected by 2 sections of glass tubing with connecting minimum length of gum rubber tubing.
2. Fritted bubbler
3. Silica gel tube
4. 1 micropipet
5. Orifice flowmeter
6. 2 Battery-operated fans (batteries supported outside carboys)
7. 1 Wash bottle
8. 1 Pipet, 25 ml
9. 1 Pipet, 20 ml
10. 6 Phillips beakers, 250 ml
11. 1 Erlenmeyer flask, 250 ml
12. 1 Graduated cylinder, 100 ml
13. 1 Buret
14. 1 Volumetric flask, 100 ml
15. 3 Pipets, Measuring, 5 ml
16. 5 N NaOH
17. 6 N H₂SO₄
18. Standard iodine solution
19. Standard thiosulfate solution
20. Starch indicator solution

Prepared by: Robert Keenan and Richard Kupel.

tained by evaporating weighed amounts of acetone in two calibrated carboys connected in series. Acetone vapor is collected from one of the carboys by each of two sampling methods. The atmosphere in the second carboy, which contains approximately the same concentration of acetone, serves to replace that withdrawn from the sample carboy.

With each sampling method, the collected acetone is contained finally in water solution. An aliquot portion of this solution is made alkaline and iodine is then added to give the iodoform reaction:

Miscellaneous tubing, connections, etc. as needed for sampling.

Procedure

Measure 0.06 ml. of C.P. acetone into each carboy. Stopper, close all screw clamps on connecting tubing, and operate the battery - driven fan motors for 45 minutes. Keep the fans operating throughout the subsequent sampling periods. Calculate the theoretical concentration of acetone vapor in each carboy (2.49 mg per liter or 1048 ppm when using a 19.1 liter carboy.) The two values should be approximately the same. It is not necessary that they be exactly the same.

Connect the silica gel tube between the sample carboy and the flowmeter. Connect the flowmeter to the vacuum source. Open the screw clamp, adjust airflow to 1 liter per minute and sample for exactly 8 minutes. Remove the silica gel tube and transfer the silica gel to an Erlenmeyer flask containing a measured 100 ml volume of distilled water. Stopper the flask and allow to stand for 30 minutes with occasional agitation (a one-hour standing period is recommended for samples collected under other circumstances).

While the silica gel is standing in water, collect another sample from the same carboy using the fritted bubbler. Add 15 ml of distilled water to about 1 inch above the fritted disk of the bubbler. Connect between the carboy and the flowmeter. (Be sure that air sample will enter through the fritted disk and exit at the top.) Apply vacuum and adjust flow to 1 liter per minute. Again sample for exactly 8 minutes. Disconnect the bubbler and transfer the sample to a 100 ml volumetric flask. Rinse bubbler with distilled

water and use rinsings to bring the volume of the sample to 100 ml. Note time and set aside for analysis.

Determine the titre of the standard iodine solution versus the standard thiosulfate solution. Pipet 20 ml of I₂ solution into a Phillips beaker. Add 30 ml of water and 2 ml of 6 N H₂SO₄. Titrate with thiosulfate solution to a faint yellow, then add 1 ml of starch indicator and continue titration to the disappearance of the blue color. (Color should not re-appear in 30 seconds.) Record the volume of thiosulfate required to titrate 20 ml of the iodine solution.

In analyzing the samples collected, each student should titrate a portion of each aqueous solution as follows:

Take the sample collected by the fritted bubbler and pipet a 25 ml aliquot into a Phillips beaker. Add 4 ml of 5 N NaOH, 25 ml of water and exactly 20 ml of iodine solution (by same pipet as used before). Mix and let stand for 15 minutes. Then add 5 ml of 6 N H₂SO₄ and titrate with thiosulfate solution, using starch indicator. Record the volume of thiosulfate solution required to titrate the excess iodine.

Transfer a 25 ml aliquot of the supernatant solution from the silica sample by means of a pipet to a Phillips beaker. Add 4 ml of 5 N NaOH, 25 ml of water and 20 ml of iodine solution. Allow to stand for 15 minutes. Add 5 ml of 6 N H₂SO₄ and titrate the excess iodine with the thiosulfate solution as described previously. Record the volume required.

Carboy No. 1		
Total volume.....	_____	liters
Wt of acetone.....	_____	grams
Carboy No. 2		
Total volume.....	_____	liters
Wt of acetone.....	_____	grams
Titre of sodium thiosulfate solution		
Volume of thiosulfate equivalent to 20 ml of 0.1 N iodine solution.....	_____	ml (a)
Fritted bubbler sample		
Rate of air flow.....	_____	liter/minute
Sampling period.....	_____	minutes
Aliquot portion.....	_____	
Volume thiosulfate required for excess 0.1N iodine solution.....	_____	ml (b)
Silica gel sample		
Rate of air flow.....	_____	liter/minute
Sampling period.....	_____	minutes
Aliquot portion.....	_____	
Volume thiosulfate required for excess 0.1N iodine solution.....	_____	ml (c)

Calculations

1. Sodium thiosulfate titre

$$1 \text{ ml thio} \left[\frac{20.00 \text{ ml iodine}}{\text{ml thio (a)}} \right] \text{ or } \text{_____ ml } 0.1N \text{ I}_2 \text{ (d)}$$

2. Milligrams of acetone per liter of air

Fritted bubbler sample:

$$20.00 \text{ ml I}_2 - \left[\text{_____ (d)} \left(\text{_____ (b) ml thio} \right) \right] = \text{_____ (e) ml } 0.1N \text{ I}_2 \text{ consumed by iodoform reaction}$$

$$\frac{\text{_____ (e) ml} \times 0.1N \times 9.68 \text{ (eq. wt. of acetone)} \times 4 \text{ (aliq. recip.)}}{1 \times 8 \text{ (rate} \times \text{samp. period)}} = \text{_____ (f) mg/l}$$

Silica gel sample:

$$20.00 \text{ ml } I_2 - \left[\frac{\text{(d)} \text{ (c) ml thio}}{\text{(g) ml } 0.1N \text{ } I_2 \text{ consumed by iodoform reaction}} \right] =$$
$$\frac{\text{(g) ml } \times 0.1N \times 9.68 \times 4}{1 \times 8} = \text{(h) mg/l}$$

3. Concentration of acetone, expressed as parts per million

Fritted bubbler:

$$\frac{\text{(f) mg/l} \times 24,450}{58.08 \text{ (mol. wt of acetone)}} = \text{--- ppm}$$

Silica gel:

$$\frac{\text{(h) mg/l} \times 24,450}{58.08} = \text{--- ppm}$$

A new method⁽²⁾ for the sampling and determination of methyl ketones is also presented. The vapors can be collected using a glass tube 4 inches in length and 5 mm inside diameter and loaded with 2 inches of activated charcoal retained by plugs of glass wool at each end. The contaminated air is drawn through the tube at rate of 1 liter per minute. Sampling time

of 10 to 20 minutes is usually sufficient depending on the concentration of the vapor. The organic vapor is desorbed from the charcoal by contact with 2 ml of carbon disulfide in a 5 ml volumetric flask. The analysis of the desorbate is then completed by means of gas chromatographic procedures.

References:

1. Otterson, E.J. and C.V. Guy: A Method of Atmospheric Solvent Vapor Sampling on Activated Charcoal in Connection with Gas Chromatography. Transactions of the 26th Annual Meeting of Am. Conf. of Govern. Ind. Hyg. page 37 (April 1964).
2. Fraust, C.L., and E.R. Hermann: Charcoal Sampling Tubes for organic Vapor Analysis by Gas Chromatography. Amer. Ind. Hyg. J. 27: 68 (Jan. 1966).

Laboratory Exercise – SPECTROPHOTOMETRIC DETERMINATION OF TOLUENE DIISOCYANATE

Object

To determine trace quantities of toluenediisocyanate in atmospheric samples by using toluenediamine as a primary standard.

Theory

Air is sampled at a rate of 3 liters per minute by bubbling through an all-glass impinger containing the absorbing medium. The method depends upon the rapid hydrolysis of toluenediisocyanate to the corresponding toluenediamine derivative, diazotization of the toluenediamine, and coupling of the stable diazo compound with N-1-naphthylethylenediamine to produce a reddish blue color which is measured spectrophotometrically. Because of the difficulty in handling toluenediisocyanate in making up standards, toluenediamine is used as the primary standard. This method is capable of determining 0.01 ppm to 2 ppm of toluenediisocyanate with 95% accuracy; above this concentration the method is about 90% accurate.

Equipment and Reagents

For field determinations the following reagents are weighed and put in separate dry bottles or vials until ready for use, then made up according to their desired solution strength; (1) Toluenediamine, (2) Sodium nitrite, (3) Sodium bromide, (4) Sulfamic acid, and (5) N-1-naphthylethylenediamine.

1. Sodium Nitrite Solution. Dissolve 3.0 grams of sodium nitrite and 5.0 grams of sodium bromide in about 80 ml of distilled water. Adjust the volume to 100 ml.
2. Sulfamic Acid Solution, 10% W/V.
3. N-1-Naphthylethylenediamine solution. Dissolve 50 mg in about 25 ml of water. Add 1 ml of concentrated hydrochloric acid and dilute to 50 ml with distilled water.
4. Absorbing Medium. To approximately 600 ml of distilled water add 35 ml of concentrated hydrochloric acid and 22 ml of glacial acetic acid and dilute to 1 liter.
5. Standard Solution A. Weigh out 140 mg of pure 2,4-toluenediamine (equivalent to 200 mg of 2,4-toluenediisocyanate). Dissolve with 660 ml of glacial acetic acid. Immediately dilute

to 1 liter in a glass-stoppered flask. This solution should be used within 15 minutes after final dilution to prepare Standard Solution B.

6. Standard Solution B. Transfer 10 ml of Standard Solution A to a glass-stoppered, 1-liter volumetric flask. This portion contains 1.4 mg (1400 μg) of toluenediamine or the equivalent of 2.0 mg (2000 μg) of toluenediisocyanate. Add 27.8 ml of glacial acetic acid so that when solution B is diluted to 1 liter with distilled water it will be 0.6N with respect to total acetic acid. One milliliter of Standard Solution B contains the equivalent of 2.0 μg of toluenediisocyanate.
7. Spectrophotometer
8. 2-cm matched test tubes for spectrophotometric measurements.
9. Glacial acetic acid.
10. Concentrated hydrochloric acid.

Procedure

To each bubbler add 15 ml of absorbing solution. The air is sampled at the rate of 3 liters per minute for 10 minutes. When sampling is complete, add 0.5 ml of the 30% sodium nitrite reagent to each bubbler, agitate gently and allow the solution to stand for 2 minutes. Add 1 ml of the 10% sulfamic acid solution, mix and allow to stand for 2 minutes. Add 1 ml of the N-1-naphthylethylenediamine solution, agitate, let stand for 5 minutes in order for the color to develop and make up to 20 ml with water. A reddish blue color indicates the presence of diisocyanate. A blank solution containing 15 ml of the absorbing medium in a clean bubbler should be carried through the entire procedure and used as a photometer zero. The samples should be transferred to 2-cm, matched test tubes and the absorbance values determined at 550 $\text{m}\mu$. The concentration of TDI is estimated from the standard curve prepared as described in Standardization.

Standardization

To a series of eight graduated cylinders add 5 ml of 1.2N hydrochloric acid and 10.0, 9.5, 9.0, 8.0, 7.0, 6.0, 5.0, and 0.0 ml, respectively, of 0.6N acetic acid. Next add 0.0, 0.5, 1.0, 2.0, 3.0, 4.0, 5.0, and 10.0 ml of Standard Solution B containing the equivalent of 0.0, 1.0, 2.0, 4.0, 6.0, 8.0, 10.0,

and 20.0 μg , respectively, of toluenediisocyanate. The solution which contains no added toluenediamine is a blank for the standardization of the method and serves as the photometer reference. To each cylinder add 0.5 ml of 30% sodium nitrite solution and continue as indicated above in the Procedure. The absorbance values are plotted vs. the equivalent concentrations of TDI to provide the standard curve. A standard curve obtained by using pure 2,4-

toluenediisocyanate as primary standard and a standard curve obtained by using 2,4-toluenediamine as primary standard are superimposable.

Calculations

$$\text{ppm} = \frac{\mu\text{g of TDI}}{\text{liters of air}} \times \frac{24.5}{\text{molecular wt. of TDI}}$$

Laboratory Exercise – DETERMINATION OF OXIDANTS (INCLUDING OZONE):
NEUTRAL BUFFERED-POTASSIUM IODIDE METHOD¹

Introduction

This method^{1,2} is intended for the manual determination of oxidants (including ozone) in the range of a few parts per hundred million (pphm) to about 10 ppm. Ozone, chlorine, hydrogen peroxide, organic peroxides, and various other oxidants will liberate iodine by this method. A positive response of about 10% of the ppm nitrogen dioxide occurs. It is customary for convenience to express the results as ozone. The advantages of this procedure over the alkaline iodide procedure are simplicity, accuracy, and precision. The analysis must, however, be completed during the period of 30 minutes to 1 hour after sampling. Sampling is conducted in midget impingers containing 1% potassium iodide in a neutral (pH 6.8) buffer composed of 0.1 M disodium hydrogen phosphate and 0.1 M potassium dihydrogen phosphate. Iodine is liberated in the absorbing reagent and measured in an appropriate instrument. Serious interfering effects occur from reducing gases and dusts.

Reagents

All reagents are made from analytical-grade chemicals. Traces of reducing impurities cause very serious errors.

Double-distilled water, used for all reagents. To distilled water in an all-glass still, add a crystal each of potassium permanganate and bariumhydroxide, and redistill.

Absorbing reagent. Dissolve 13.61 g of potassium dihydrogen phosphate, 14.20 g of anhydrous disodium hydrogen phosphate (or 35.82 g of dodecahydrate salt), and 10.00 g of potassium iodide successively and dilute the mixture to exactly 1 liter. Age at room temperature for at least 1 day before using. This solution may be stored for several weeks in a glass stoppered brown bottle in the

refrigerator, or for shorter periods at room temperature. Do not expose to sunlight.

Standard iodine solution, 0.05 N. Dissolve successively 16.0 g of potassium iodide and 3.173 g of iodine; make to a volume of exactly 500 ml. Age for at least 1 day before using. Standardization is unnecessary if the weighing is carefully done. (The solution may also be standardized by titration with sodium thiosulfate by using starch indicator.)

Apparatus

Absorber. All-glass midget impingers with a graduation mark at 10 ml, similar to that shown in Figure 3, are used. (Other bubblers with nozzle or open-end inlet tubes may be used. Fritted bubblers tend to give comparatively low results.) Impingers must be kept scrupulously clean and dust free. All traces of grease must be removed by treatment with dichromate-concentrated sulfuric acid solution followed by tap and distilled water.

Air-metering device. A glass rotameter capable of measuring a flow of 1 to 2 liters per minute with an accuracy of $\pm 2\%$ is recommended.

Air pump. An appropriate suction pump capable of drawing the required sample flow for intervals of up to 30 minutes is suitable. It is desirable to have a trap on the inlet to protect the needle valve and pump against accidental flooding with absorbing reagent and consequent corrosion.

Spectrophotometer. A laboratory instrument suitable for measuring the yellow color at 352 $m\mu$, with stoppered tubes or cuvettes (suitable for ultraviolet use), is recommended.

Analytical Procedures

Collection of samples. Assemble a train composed of a midget impinger, rotameter, and pump. Use ground-glass connections upstream from the impinger. Butt-to-butt glass connections with slightly greased tygon tubing may also be used for connections without losses if exposed tubing lengths are kept minimal. Pipet exactly 10 ml of the absorbing solution into the midget impinger and sample at a flow rate of 1 to 2 liters per minute. Note the total volume of the air sample. If the sample air temperature and pressure deviate greatly from 25°C and 760 mm Hg, measure and record these values. Sufficient air should be sampled so that the equivalent of 0.5 to 10 μ l of ozone is absorbed. Sampling periods of longer than 30 minutes should be

¹Prepared by Bernard E. Saltzman Ph.D., Laboratory of Engineering and Physical Sciences, Division of Air Pollution, Public Health Service, Approved by the Interbranch Chemical Advisory Committee, March 1964.

Reprinted from – Selected Methods For The Measurement Of Air Pollutants, Division Of Air Pollution, U.S. Public Health Service, Publication No. 999-AP-11, May 1965.

avoided. For a flow rate of 2 liters per minute, a 30-minute sample should yield a sensitivity of 0.01 ppm. Do not expose the absorbing reagent to direct sunlight.

Analysis. If appreciable evaporation has occurred, add distilled water to restore the volume to the 10-ml graduation mark. Transfer the exposed absorbing reagent (without diluting with rinse water) to a clean colorimeter tube or cuvette. During the period of 30 to 60 minutes after the sampling period, determine the absorbance at 352 $m\mu$, using a tube or cuvette freshly filled with distilled water as the reference. A few additional readings at earlier and later times should be made occasionally when practicable to check on the color stability. Every few days, determine the blank correction (to be deducted from sample absorbances) by reading the absorbance of unexposed reagent.

Samples having a color too dark to read may be quantitatively diluted with additional absorbing reagent, and the absorbance of the diluted solution read. The dilution factor must then be introduced into the calculations.

Standardization. Freshly prepare 0.0025 N iodine standard by pipetting exactly 5 ml of the 0.05 N standard stock solution into a 100-ml volumetric flask and diluting to mark with absorbing reagent. Place 0.2-, 0.4-, 0.6-, and 0.9-ml portions (measured accurately in a graduated pipet or small buret) of the diluted standard iodine in separate 25-ml volumetric flasks and dilute to marks with absorbing reagent. Mix thoroughly. Immediately after preparation of this known series read the absorbance of each at 352 $m\mu$ in the usual manner.

Calculations. For convenience, standard conditions are taken as 760mm of mercury and 25°C; thus, only slight correction by means of the well-known perfect gas equation is required to get V , the standard volume in liters of the air sampled. Ordinarily this correction may be omitted. Quantities, customarily expressed in terms of ozone, may be expressed as microliters, defined as V times ppm ozone. It has been determined empirically that 1 mole of ozone liberates 1 mole of iodine (I_2) by this procedure.

Plot the corrected absorbances of the standard colors against the exact calculated normalities of the corresponding diluted iodine solutions. Beer's Law is followed. Draw the straight line giving the

best fit and determine the normality of iodine solution intercepted at an absorbance of exactly 1. This value multiplied by 1.224×10^5 * gives the standardization factor M , defined as the number of microliters of ozone required by 10 ml of absorbing reagent to give an absorbance of exactly 1. For 2-cm cells this value is 4.8.

Results for samples are computed as follows:

$$\text{ppm oxidant (expressed as } O_3) = \text{corrected absorbance} \times M/V (1)$$

If the volume of the air sample V , is a simple multiple of M , calculations are simplified. Thus, for the M value of 4.8 previously cited, if exactly 4.8 liters of air are sampled through the impinger, the corrected absorbance is also ppm directly. If other volumes of absorbing reagent are used, V is taken as the volume of air sample per 10 ml of absorbing reagent.

Discussion of Procedure

Sampling efficiency. When two impingers are placed in series, iodine will very rarely be liberated from the solution in the second absorber. Thus sampling efficiency is very high. Fritted bubblers, which also appear to have equally high sampling efficiencies, usually give, however, less iodine for a given amount of ozone and should not, therefore, be used. This is due to the complex chemistry of ozone in iodine solutions.²

Stability of colors. About 90% of the iodine is liberated by ozone immediately and the remaining 10% appears to be liberated by a single slow-reacting component (probably H_3PO_6 produced by the ozone in a side reaction) with a half-life of about 10 minutes. Thus the color will gradually increase until about 45 minutes after sampling, after which fading will begin. Good results are obtained by reading during the period of 30 to 60 minutes after sampling.

Oxidants other than ozone will also liberate iodine but at a slower rate. Some estimate of the presence of such materials or of fading due to reducing substances can be made for each situation by making occasional measurements over an extended period of time. Use of analytical-grade reagents and of carefully cleaned glassware reduces losses of iodine and fading processes. Do not expose the reagent to direct sunlight, since additional iodine may be released.

Comparison with 2% potassium iodide reagent. A similar reagent, containing 2% potassium iodide in the same buffer that has been adjusted to pH 7.0 with sodium hydroxide pellets, is in use.³ Both

*Standard molar volume (760 mm Hg, 25°C) = 24.47 liters. Hence 1 μ mole I_2 = 24.47 μ l O_3 , and 10 ml 1 N iodine = $5 \times 10^3 \mu$ mole I_2 = $1.224 \times 10^5 \mu$ l O_3 .

reagents should give comparable results. Color development as well as fading is slower in the 1% reagent, so that a longer time interval should be available for accurate reading.

Interferences. The negative interferences from reducing gases such as sulfur dioxide and hydrogen sulfide are very serious (probably on a mole-to-mole equivalency). The procedure is very sensitive to reducing dusts, which may be present in the air or on the glassware. Losses of iodine occur even on clean glass surfaces, and thus the manipulations should minimize this exposure.

Elimination of the interference of sulfur dioxide, even when it was present in as high as hundredfold ratio to oxidant, has been accomplished recently⁴ by

incorporating an extra large (140-ml) absorbing U-tube in the sampling train upstream from the impinger. The absorbent, which removes sulfur dioxide without loss of oxidant, is glass fiber paper impregnated with chromium trioxide. (Drop 15 ml of aqueous solution containing 2.5 g chromium trioxide and 0.7 ml concentrated sulfuric acid uniformly over 60 in.² of paper, and dry in an oven at 80 to 90°C for 1 hour. Cut the paper into 1/4- x 1/2-in. strips, each folded once into a V-shape, pack into the U-tube, condition by drawing air through tube overnight.) The absorbent has a long life (at least 1 month). If it becomes visibly wet from sampling humid air, it must be dried (with dry air) before further use.

References

1. Byers, D.H., Saltzman, B.E., Determination of Ozone in Air by Neutral and Alkaline Iodide Procedures, J. Am. Indust. Hyg. Assoc. 19:251-7. 1958.
2. Saltzman, B.E., Gilbert, N., Iodometric Micro-determination of Organic Oxidants and Ozone, Anal. Chem. 31:1914-20. 1959.
3. California State Department of Public Health, Tentative Method of Analysis for Total Oxidant Content of the Atmosphere, SDPH 1-20 in "Recommended Methods in Air Pollution Measurements." 1960.
4. Saltzman, B.E., Wartburg, A.F., Jr. Absorption Tube for Removal of Interfering Sulfur Dioxide in Analysis of Atmospheric Oxidant, Anal. Chem. 37:779. 1965.

Laboratory Exercise - SAMPLING AND DETERMINATION OF FLUORIDE

Object

The object of this section is to present methods which can be conveniently used for the determination of fluorides in different types of samples.

Theory

Among the many methods suggested for the determination of fluoride, the colorimetric methods are generally accepted to be the most satisfactory at the present time. These methods are based on the reaction between fluoride ion and a zirconium-dye lake. Fluoride reacts with the dye lake, dissociating a portion of it into a colorless complex ion (ZrF_6^{--}) and the dye. As the fluoride concentration is increased, the color becomes progressively lighter or different in hue, depending on the dye used. Because these methods are subject to errors when interfering ions are present, it may be necessary to separate fluoride from possible interferences before making the fluoride determination.

Fluoride-bearing dusts may be collected by any of the standard techniques involving filtration, electrostatic precipitation, or impingement. Fumes are sampled with the electrostatic precipitator or impingers. Gases are sampled with Greenburg-Smith impingers or fritted bubblers containing 0.1 N NaOH. Urine samples should be collected in clean borosilicate glass bottles.

Equipment and Reagents

Spectrophotometer - any spectrophotometer for use at 570 $m\mu$ and providing a light path of at least 1 cm.

A photometer equipped with a filter having maximum transmittance at 500-580 $m\mu$ and providing at least a 1-cm light path may be used instead of a spectrophotometer.

Standard Fluoride Solution - Dissolve 0.221 g NaF in distilled water and dilute to 1000 ml. Dilute 10 ml of this stock solution to 100 ml with distilled water; 1 ml is equivalent to 10 mg of fluoride ion.

SPADNS Solution (dye solution) - Dissolve 0.958g of SPADNS [Eastman organic chemicals #7309, sold as 4,5-dihydroxy-3-(parasulfophenylazo)-2,7-naphthalenedisulfonic acid trisodium salt] in distilled water and dilute to 500 ml.

Zirconium-Acid Solution - Dissolve 0.133g zirconium oxychloride octahydrate ($ZrOCl_2 \cdot 8H_2O$) in 25 ml of distilled water, add 350 ml of concentrated HCl (reagent grade, Sp. gr. 1.19) and dilute to 500 ml with distilled water.

Reference Solutions - Mix 10 ml of SPADNS solution with 100 ml of distilled water. Dilute 7 ml of concentrated HCl to 10 ml and add to the diluted SPADNS solution. This solution is used for setting the reference point (zero) of the spectrophotometer. The solution is stable and may be reused.

Procedure

Preparation of standard curve - Prepare a series of fluoride standards in the range of 0-70 micrograms by diluting the appropriate quantities of standard fluoride solution to 50 ml with distilled water. Add exactly 5 ml each of SPADNS solution and zirconium-acid solution or 10 ml of a mixture containing equal volumes of the two reagents. Mix each standard, set the spectrophotometer to zero absorbance with the reference solution, and measure the absorbance of each standard at 570 $m\mu$.

Prepared by: Richard E. Kinser

Plot a curve of micrograms of fluoride versus absorbance. A new standard curve must be prepared whenever a fresh batch of reagent is prepared or a different standard temperature is desired.

Sample Treatment - Before fluoride can be determined quantitatively by colorimetric procedures it must be present in solution as the fluoride ion, free from organic matter and ionic interferences. Samples of urine and body fluids containing organic matter must first be ashed under alkaline conditions to remove the organic matter. Alkaline conditions must be maintained during ashing to prevent the loss of fluoride. Calcium oxide (low in fluoride) or magnesium acetate have been used for this purpose. Concentration of samples must also be done under alkaline conditions. If the sample contains known interferences such as phosphate, aluminum, iron, and hexametaphosphate a separation step is necessary. Fluoride is separated by either of the two described distillation procedures. Free chlorine in a sample may be destroyed by the addition of 1 drop of sodium arsenite solution (5g NaAsO_2 per liter) for each 0.1 mg of chlorine.

Distillation Procedures - (a) Steam distillation¹ - The commercial distilling apparatus is satisfactory (Ace Glass Cat. No. 6431 or Scientific Glass Apparatus Company, Cat. No. JD 2130). The thermometer bulb and steam inlet should extend to within 1/16 inch of the bottom of the distilling flask. Bumping may be minimized by placing a few glass beads in the steam generator and distilling flask. The distilling flask delivery tube must slope upward and have no restrictions. Joints must be tight fitting for quantitative recovery of fluoride. To eliminate possible contamination from glassware the apparatus should be steamed out before use. The following procedure may be used for this purpose. Place 125 ml of distilled water in the distilling flask and carefully add 25 ml of concentrated H_2SO_4 or 60% HClO_4 . Mix thoroughly and

add a few glass beads. Assemble the apparatus, connect to the steam generator and start distillation. By-pass steam until the temperature in the distilling flask reaches 135°C. At this point close steam by-pass and introduce the steam to the distilling flask. Maintain temperature between 130 and 150°C (130-140°C for HClO_4). Distill at the rate of 5 ml per minute and collect at least 200 ml of distillate. Discard distillate. To the steam cleaned distilling flask, add a suitable aliquot of the aqueous sample. Distill as above and collect 200 ml of distillate. Chlorides may be held back in the distillation by adding silver sulfate or silver perchlorate to the distilling flask. This distillate is used for the colorimetric determination of fluoride.

(b) Direct distillation from sulfuric acid² - This method produces no dilution of the sample. Sulfate carry-over during the latter stages of distillation is pronounced; however, the volume of distillate serves to hold the final sulfate concentration within tolerable limits.

A distillation apparatus such as Corning No. 3360 may be used. A 250-ml distilling flask is adequate. Obstruction in the vapor path and trapping of liquid in the adapter or condenser must be avoided. These conditions may enhance sulfate carry-over. Place 100 ml of distilled water in the distilling flask and add carefully 50 ml of concentrated H_2SO_4 . Swirl until well mixed and add 20-30 glass beads. Connect the apparatus and begin heating slowly at first, then increase heat. Distill as rapidly as the condenser efficiency will allow (distillate must be cool). Continue distillation until the temperature reaches 180°C and stop. Discard distillate. This procedure will remove fluoride contamination and serves to adjust the acid-water ratio for sample distillation.

After cooling the acid-water mixture to 120°C or less, add the sample or aliquot diluted to 50 ml and mix thoroughly.

Silver sulfate should be added to the distilling flask at the rate of 5 mg per mg of chloride when high chloride samples are to be distilled. Distill as before until the temperature reaches 180°C. Hold this distillate for colorimetric estimation of fluoride.

Color Development³ - Adjust the temperature of a 50 ml aliquot of the distillate (or other sample solution) or a smaller aliquot diluted to 50 ml to the same temperature used during the development of the standard curve. Add exactly 5 ml each of the SPADNS solution and zirconium-acid solution (10 ml of a mixture containing equal volumes of the two reagents also may be used). Mix well and measure absorbance at 570 m μ

after first setting the reference point of the spectrophotometer with the reference solution. If the absorbance falls beyond the range of the standard curve repeat the procedure using a smaller aliquot. Known interferences such as phosphate hexametaphosphate, iron and aluminum may be separated with the described distillation procedures.

Calculations

Determine the quantity of fluoride in the analyzed aliquot by referring to the standard curve. The fluoride concentration in the original sample is determined by allowing for dilution factors and original sample size.

References

1. Boltz, D.F.: Colorimetric Determination of Nonmetals, Chapt. VIII, Interscience Publishers, Inc., New York (1958).
2. Bellack, E.: Simplified Fluoride Distillation Method. J. Amer. Water Works Assoc., 50: 530 (1958).
3. Bellack, E. and P.J. Schonboe: Rapid Photometric Determination of Fluoride in Water. Anal. Chem., 30: 2032 (1958).

Laboratory Exercise - DETERMINATION OF NITROGEN DIOXIDE AND NITRIC OXIDE: SALTZMAN METHOD¹

Introduction

The Saltzman method is intended for the manual determination of nitrogen dioxide in the atmosphere in the range of a few parts per billion (ppb) to about 5 ppm. Sampling is conducted in fritted bubblers. The method is also applicable to the determination of nitric oxide after it is converted to an equivalent amount of nitrogen dioxide by passage through a permanganate bubbler.³ Concentrations of both gases of 5 to 100 ppm may be sampled in evacuated bottles. The nitrogen dioxide is absorbed in Griess-Saltzman reagent.² A stable pink color is produced within 15 minutes and may be read visually or in an appropriate instrument. Only slight interfering effects occur from other gases.

Reagents

All reagents are made from analytical-grade chemicals in nitrite-free water prepared, if necessary, by redistilling distilled water in an all-glass still after adding a crystal each of potassium permanganate and of barium hydroxide. They are stable for several months if kept well stoppered in brown bottles in the refrigerator. The absorbing reagent should be allowed to warm to room temperature before use.

N-(1-Naphthyl)-ethylenediamine dihydrochloride, 0.1%. Dissolve 0.1g of the reagent in 100 ml of water. This is a stock solution.

Absorbing reagent. Dissolve 5 g of sulfanilic acid in almost a liter of water containing 140 ml of glacial acetic acid. Gentle heating is permissible, if desired, to speed up the process. To the cooled mixture, add 20 ml of the 0.1% stock solution of

N-(1-Naphthyl)-ethylenediamine dihydrochloride, and dilute to 1 liter. Avoid lengthy contact with air during both preparation and use, since this will result in discoloration of reagent because of absorption of nitrogen dioxide.

Standard sodium nitrite solution, 0.0203 g per liter. One ml of this working solution produces a color equivalent to that of 10 μ l of nitrogen dioxide (10 ppm in 1 liter of air at 760 mm of mercury and 25°C). Prepare fresh just before use by dilution from a stronger stock solution containing 2.03 g of the reagent grade granular solid (drying is unnecessary) per liter. The stock solution should be stable for 90 days.

Acid permanganate, used for nitric oxide determination. Dissolve 2.5 g of potassium permanganate in about 90 ml water, add 2.5 g of concentrated sulfuric acid (or 5.2 ml of 1:3 H₂SO₄) and dilute to 100 ml with distilled water. Prepare at frequent intervals, since the keeping quality is not good; discard when an appreciable precipitate of brown manganese dioxide is noted.

Apparatus

Absorber. A specially ordered all-glass bubbler with a 60- μ maximum pore diameter frit (Corning designation "coarse" or Ace designation "C"), similar to that illustrated in Figure 1, is used.

Acid permanganate bubblers. A midget impinger with a nozzle about 1 mm in diameter and ground glass joints may be used (Figure 3). Accumulated deposits of manganese dioxide may be readily cleaned out by warming with a solution of hydroxylamine hydrochloride or oxalic acid.

¹Prepared by: Bernard E. Saltzman, Ph.D., Laboratory of Engineering and Physical Sciences, Division of Air Pollution, Public Health Service. Approved by the Interbranch Chemical Advisory Committee, January 1964.

Reprinted From - Selected Methods for the Measurement of Air Pollutants, Division of Air Pollution, U.S. Public Health Service, Publication NO. 999-AP.11, May, 1965.

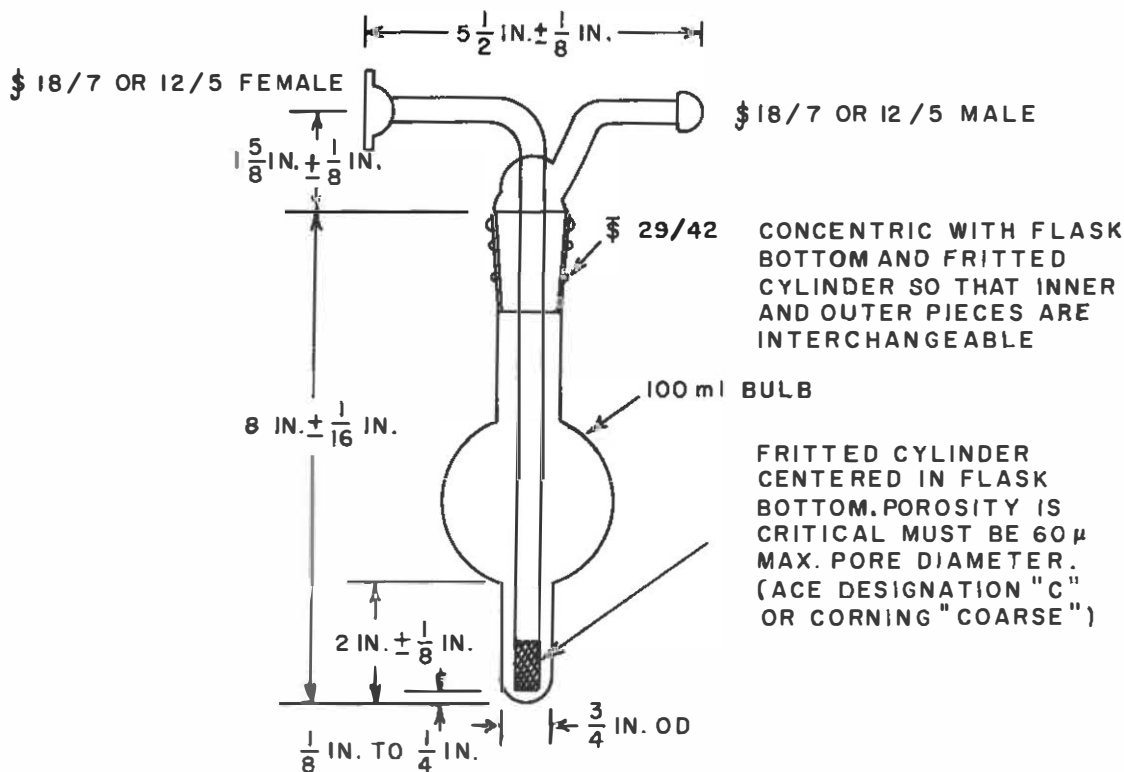

FIGURE 1. FRITTED BUBBLER FOR SAMPLING NITROGEN DIOXIDE.

Air-metering device. A glass rotameter capable of accurately measuring a flow of 0.4 liter per minute is recommended.

Air pump. An appropriate suction pump capable of drawing the required sample flow for intervals of up to 30 minutes is suitable. It is desirable to have a tee connection at the intake. The inlet connected to the sampling train should have an appropriate trap and needle valve (preferably of stainless steel). The second inlet should have a valve for bleeding in a large excess flow of clean air to prevent condensation of acetic acid vapors from the absorbing reagent, with consequent corrosion of the pump.

Spectrophotometer or colorimeter. A laboratory instrument suitable for measuring the pink color at $550 \text{ m}\mu$, with stoppered tubes or cuvettes, is recommended.

Analytical Procedure for Nitrogen Dioxide

Sampling train. Assemble, in order, a fritted absorber, rotameter, and pump. Use ground-glass connections upstream from the absorber. Butt-to-butt glass connections with slightly greased tygon or pure gum rubber tubing may also be used for con-

nections without losses if lengths are kept minimal. Since the rotameter operates at an appreciable vacuum, make one dummy run to calibrate it against another rotameter or wet test meter installed upstream from the bubbler and operating at atmospheric pressure. If preferred, the sampling rotameter may be used upstream from the bubbler provided occasional checks are made to show that no nitrogen dioxide is lost. In either case, for accurate measurements, the rotameter must be kept free from spray or dust.

Sampling procedure. Pipet exactly 10 ml of absorbing reagent into the fritted bubbler. Draw an air sample through it at the rate of 0.4 liter (or less) per minute until sufficient color has developed (about 10 minutes). Note the total air volume sampled. If the sample air temperature and pressure deviate greatly from 25°C and 760 mm Hg, measure and record the values.

Determination. After collection or absorption of the sample, a direct red-violet color appears. Color development is complete within 15 minutes at ordinary temperatures. Compare with standards visually or transfer to stoppered cuvettes and read in a spectrophotometer at $550 \text{ m}\mu$, using unexposed reagent as

a reference. Colors may be preserved, if well stoppered, with only 3 to 4% loss in absorbance per day; however, if strong oxidizing or reducing gases are present in the sample in concentrations considerably exceeding that of the nitrogen dioxide, the colors should be determined as soon as possible to minimize any loss.

Standardization. Add graduated amounts of standard sodium nitrite solution up to 1 ml (measured accurately in a graduated pipet or small buret) to a series of 25-ml volumetric flasks, and dilute to marks with absorbing reagent. Mix, allow 15 minutes for complete color development, and read the colors.

Good results can be obtained with these small volumes of standard solution if they are carefully measured. If preferred, however, larger volumes may be used with correspondingly larger volumetric flasks.

Calculations. For convenience, standard conditions are taken as 760 mm of mercury and 25°C; thus, only slight correction by means of the well-known perfect gas equation is ordinarily required to get V, the standard volume of the air sample in liters. Quantities of nitrogen dioxide may be expressed as microliters, defined as V times the ppm nitrogen dioxide. It has been determined empirically that 0.72 mole of sodium nitrite produces the same color as 1 mole of nitrogen dioxide; hence, 2.03 μg of sodium nitrite is equivalent to 1 μl of nitrogen dioxide.* The 1-ml standard is equivalent to 4 μl of nitrogen dioxide per 10 ml of absorbing reagent.

Plot the absorbances of the standard colors, corrected for the blank, against the milliliters of standard solution. Beer's Law is followed. Draw the straight line giving the best fit and determine the slope (the value in milliliters of sodium nitrite intercepted at absorbance of exactly 1). This value multiplied by 4 gives the standardization factor, M, defined as the number of microliters of nitrogen dioxide required by 10 ml of absorbing reagent to give an absorbance of 1. For 2-cm cells the value was 3.65. Then: (1)

$$\text{ppm nitrogen dioxide} = \text{corrected absorbance} \times M/V$$

If the volume of the air sample, V, is a sample multiple of M, calculations are simplified. Thus, for the M value of 3.65 previously cited, if exactly 3.65 liters of air is sampled through a bubbler, the cor-

rected absorbance is also ppm directly. If other volumes of absorbing reagent are used, V is taken as the volume of air sample per 10 ml of reagent.

ANALYTICAL PROCEDURE FOR NITRIC OXIDE

Sampling for concentrations of 10 ppm and less.

Assemble a sampling train composed of, in order, rotameter, fritted absorber, acid permanganate bubbler (with a nozzle rather than fritted inlet), fritted absorber, and pump. Pipet exactly 10 ml of absorbing reagent into each fritted absorber (first and third in the train). The second bubbler in the train should contain 10 ml of the acid permanganate solution, which may be reused several times. Draw an air sample through at a rate of 0.4 liter per minute (or less) until sufficient color has developed (about 10 minutes). After allowing an additional 15 minutes for full color development, the solution from the third bubbler may be read in the spectrophotometer and the nitric oxide computed. Colors too dark to read may be quantitatively diluted with unexposed absorbing reagent. If a simultaneous determination of nitrogen dioxide is desired it may be obtained by reading the colored solution from the first bubbler in a similar manner.

DISCUSSION OF PROCEDURES

Sampling efficiency. The porosity of the fritted bubbler is important, as well as the flow rate. An efficiency of 95% may be expected with a flow rate of 0.4 liter per minute and a maximum pore diameter of 60 μ. Considerably lower efficiencies are obtained with coarser frits, but these may be utilized if the flow rate is reduced. Since the quality control by some manufacturers is rather poor, it is desirable to measure the porosity of a new absorber experimentally as follows:

Carefully clean the apparatus with dichromate-concentrated sulfuric acid solution and rinse thoroughly with distilled water. Assemble the bubbler, add sufficient distilled water to cover the fritted portion, and measure the vacuum required to draw the first perceptible stream of air bubbles through the frit. The following equation is then used:

$$\text{maximum pore diameter } (\mu) = \frac{30 s}{P} \quad (2)$$

Where s is the surface tension of water at the test temperature in dynes per cm (73 at 18°C, 72 at 25°C, and 71 at 31°C), and P is the measured vacuum in mm of Hg.

Nitrite equivalent of nitrogen dioxide. Stand-

*Molar volume at 25°C, 760 mm Hg is 24.47 liters.

Molecular weight NaNO₂ = 69.00; hence:

$$1 \mu\text{l NO}_2 = \frac{10^{-6}}{24.47} \text{ moles NO}_2 = \frac{10^{-6}}{24.47} \times 0.72 \times$$

$$69.00 = 2.03 \times 10^{-6} \text{ g NaNO}_2.$$

ardization is based upon the empirical observation that 0.72 mole of sodium nitrite produces the same color as 1 mole of nitrogen dioxide. Using sodium nitrite is much more convenient than preparing accurately known gas samples for standardizing.

Efficiency of nitric oxide conversion. Conversion efficiency of nitric oxide to nitrogen dioxide by the permanganate bubbler may be commonly as low as 70%. This depends somewhat upon the quality of the permanganate solution and the design of the bubbler. Few data have been published on conversion efficiencies.

Conversion efficiencies of 95 to 100% have been reported recently¹ for an alternative method using a 17-mm OD glass U tube, containing one sheet of impregnated glass fiber paper cut into 1/4-in. strips, at a flow rate of 290 ml per minute. (A stack of 25 sheets of 7-cm-diameter paper is impregnated with 25 ml of 2.5% $\text{Na}_2\text{Cr}_2\text{O}_7$, 2.5% H_2SO_4 , and dried in a vacuum oven at 160°F, or on a hot plate at 200°F. Discard top and bottom sheets, store in closed bottle.) The useful life of the paper is limited, and it deteriorates rapidly when exposed to reagent vapors downstream from a bubbler. Hence a different sampling train, composed of rotameter, paper, fritted absorber, and pump, is used. The analysis yields the total of nitric oxide and nitrogen dioxide. A separate analysis of the later gas must be made and deducted to give the concentration of nitric oxide.

Effects of interfering gases. A fivefold ratio of ozone to nitrogen dioxide will cause a small interference, the maximal effect occurring in 3 hours. The reagent assumes a slightly orange tint.

A 10-fold ratio of sulfur dioxide produces no effect. A 30-fold ratio slowly bleaches the color to a slight extent. The addition of 1% acetone to the reagent before use retards the fading by forming a temporary addition product with sulfur dioxide. This permits reading within 4 to 5 hours (instead of the 45 minutes required without the acetone) without appreciable interferences.

The interferences from other nitrogen oxides and other gases that might be found in polluted air are negligible.

SAMPLING RELATIVELY LARGE CONCENTRATIONS (MORE THAN 5ppm) WITH EVACUATED BOTTLES

Grab-sample bottles. Ordinary glass-stoppered borosilicate glass bottles of 30- to 250-ml sizes are suitable if provided with a mating ground joint attached to a stopcock for evacuation. Calibrate the volume by weighing with connecting piece, first

empty, then filled to the stopcock with distilled water.

Fifty- or one hundred-milliliter glass syringes are convenient (although less accurate) for moderately large concentrations.

Sampling for nitrogen dioxide. Sample in evacuated bottles of appropriate size (30 ml for up to 100 ppm, to 250 ml for down to 1 ppm) containing exactly 10 ml (or other convenient volume) of absorbing reagent. First grease the joint lightly with silicone or fluorocarbon grease. If a source of vacuum is available at the place of sampling, it is best to evacuate just before sampling to eliminate any uncertainty about loss of vacuum. A three-way Y stopcock connection is convenient. One leg is connected to the sample source, one to the vacuum pump, and the third to a tee attached to the bottle and to a mercury manometer or accurate gauge. In the first position of the Y stopcock, the bottle is evacuated to the vapor pressure of the absorbing reagent, and the actual vacuum is read. In the second position of the Y stopcock, the sampling bottle is closed and the vacuum pump draws air through the sampling line to flush it thoroughly. In the third position of the Y stopcock, the sampling line is connected to the evacuated bottle, and the sample is collected. The stopcock on the bottle is then closed. Allow 15 minutes with occasional shaking for complete absorption and color development. For calculation of the standard volume of the sample, the pressure is recorded as the difference between the filled and evacuated conditions, and the uncorrected volume is that of the bottle plus that of the connection up to the stopcock minus the volume of absorbing reagent.

Another, more convenient but less accurate field method for moderately large concentrations is to use 50- or 100-ml glass syringes. Ten ml of absorbing reagent is kept in the capped syringes, and 40 or 90 ml of air is drawn in at the time of sampling. The absorption of nitrogen dioxide is completed by capping and shaking vigorously for 1 minute, after which the air is expelled. Additional air may be drawn and in the process repeated several times if necessary to develop sufficient final color.

The syringe method is also useful when appreciable concentrations of nitric oxide are suspected. Interference caused by the air oxidation of nitric oxide to nitrogen dioxide is minimized by expelling the air sample immediately after the 1-minute absorption period.

Sampling for nitric oxide. Sample in an evacuated bottle containing absorbing reagent, as described in the procedure for nitrogen dioxide. Close the stopcock and allow sufficient time for the air oxida-

tion of the nitric oxide to be substantially completed (Figure 2), shaking the bottle at intervals to prevent loss of nitrogen dioxide on the glass. Read the color in the manner previously described. The nitrogen dioxide initially present may be separately

determined in a syringe and deducted if appreciable. The calculated concentration of nitric oxide may be corrected for incomplete conversion according to Figure 2.

Low conversions should be avoided for accurate results. A second correction for fading of the color

(about 3% of the absorbance per day) may be made for a prolonged absorption period.

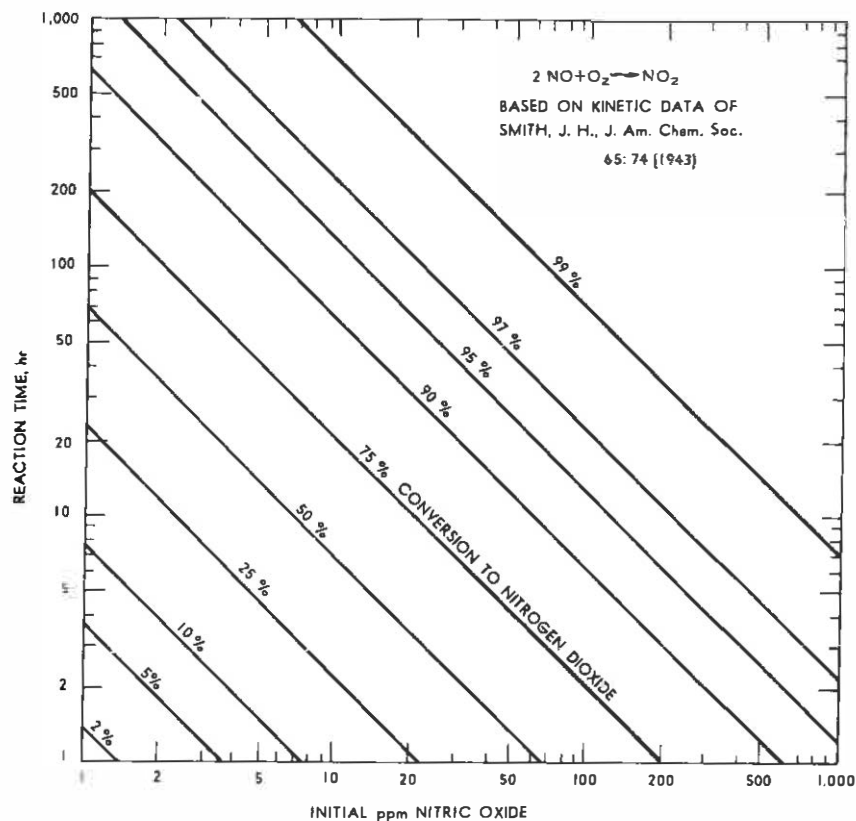

FIGURE 2. OXIDATION OF NITRIC OXIDE BY AIR AT 25°C.

References

1. Ripley, D.L., Clingenpeel, J.M., and Hurn, R.W., Continuous Determination of Nitrogen Oxides in Air and Exhaust Gases, *Internat. J. Air and Water Poll.* (London) 8: 455-63. 1964.
2. Saltzman, B.E., Colorimetric Microdetermination of Nitrogen Dioxide in the Atmosphere, *Anal. Chem.* 26: 1949-55. 1954.
3. Thomas, M.D., MacLeod, J.A., Robbins, R.C., Goettelman, R.C., Eldridge, R.W., and Rogers, L.H., Automatic Apparatus for Determination of Nitric Oxide and Nitrogen Dioxide in the Atmosphere, *Anal. Chem.* 28: 1810-16. 1956.

Laboratory Exercise - DETERMINATION OF AROMATIC HYDROCARBONS

Method I. Chemical Procedure

Object

To determine the total aromatic hydrocarbon content of a solvent mixture by chemical methods, and to determine benzene, toluene, and xylene (ortho, meta, and para) by chemical methods.

Theory - determination of aromatic hydrocarbons

The quantity of aromatic hydrocarbons present in a sample mixture can be estimated within 5% by sulfonation of the aromatic hydrocarbon with fuming sulfuric acid and subsequent dissolution of the sulfonated material in the acid. Paraffin hydrocarbons are not sulfonated and remain insoluble in the fuming sulfuric acid.

Equipment and Reagents

1. Pipet, 5 or 10 ml
2. Babcock flask graduated in 0.1 ml
3. 20% fuming sulfuric acid

Calculations

$$\% \text{ aromatics} = \frac{\text{ml Sample} - \text{ml Insoluble}}{\text{ml Sample}} \times 100$$

4. Concentrated sulfuric acid
5. Centrifuge cups
6. Centrifuge
7. Heated water bath

Procedure

Pipet a 5 to 10 ml aliquot of the sample into a Babcock flask and cool in running water. Add slowly and very carefully 20% fuming sulfuric acid with constant stirring. Continue to add the acid until there is no further development of heat. Permit the mixture to stand for 30 minutes at 40-50°C and then add sufficient concentrated sulfuric acid to bring the mixture up into the neck of the flask. Place the flask in a centrifuge cup, pack sand around it, accurately counterbalance the cups, and centrifuge. If the sample consists entirely of aromatic hydrocarbons there will be no insoluble layer. For general work, it is recommended that insoluble layers of under 5% be neglected. Readings of insoluble layers greater than 5% are considered accurate to within 2 to 3%.

Prepared by: Robert L. Larkin

Object - determination of benzene, toluene, and xylene.

Theory - (a) Benzene can be determined by the Dolin method, which is a modification of the butanone procedure. In this method, the color which results when benzene is present is stable in the presence of acetic acid, while the colors produced by toluene, xylene, and other related compounds disappear rapidly upon adding acetic acid.

(b) Toluene is nitrated with fuming nitric acid instead of both sulfuric and nitric acids. The acid is diluted with water, neutralized, extracted with butanone and, upon adding potassium hydroxide, a reddish-blue color is developed.

(c) Xylene is determined by Weber's test. The sample is treated with concentrated nitric and sulfuric acids and is heated to boiling. Upon cooling and subsequent addition of water, a milky suspension is formed. This is treated with cyclohexanol and sodium hydroxide. A green color indicates the presence of xylene. Benzene and toluene must not be present in amounts greater than 10%.

Equipment and Reagents

1. Concentrated H_2SO_4
2. Fuming HNO_3
3. Flask, volumetric, 100 ml
4. Pipets, 1 ml, 10 ml, 25 ml
5. Distilled H_2O
6. NaOH (40%)
7. KOH (50%)
8. Litmus paper
9. Butanone
10. Buret, funnel top
11. Ether
12. 95% ethanol
13. Separatory funnels
14. Cyclohexanol
15. 2N NaOH
16. Test tubes
17. Glass stoppered bottles (small)

Procedure

(a) Determination of benzene. Treat 0.1 ml of the sample in a separatory funnel with 2 ml of an equal volume mixture of concentrated sulfuric acid and fuming nitric acid. After 10 minutes, add 25 ml of water and cool. Extract the nitrated material with 25 ml of ether and wash the extract with 25 ml of water. Transfer the ether extract to a 100 ml volumetric flask. Make to volume with 95% ethanol. Transfer a 10 ml aliquot to a test tube and add 1 ml of butanone, 2 drops of 40% sodium hydroxide, shake and allow to stand for 10 minutes. If benzene is present in the original solution, a crimson color will appear. The addition of 5 drops of glacial acetic acid will eliminate any color caused by the presence of toluene, xylene and other benzene homologs.

(b) Determination of toluene. Treat a second 0.1 ml aliquot of the sample with 1 ml of fuming nitric acid, transfer the acid mixture to small flask or bottle fitted with an unlubricated glass stopper. Wash the sample container with six 1 ml portions of water and add to the acid mixture. Neutralize the acid solution in a water bath at 25-30°C by slowly titrating with 50% potassium hydroxide. Litmus paper may be used as the indicator. Add an excess of 2 to 3 drops of the alkali. Add 10 ml of butanone and shake occasionally for 10 minutes. It is important at this stage that the bottle and contents be kept warm, at about 25-30°C, to prevent salts from crystallizing. Transfer the liquid to a 50 ml buret. Draw off the butanone layer into a test tube and treat with 1.5 ml of 50% potassium hydroxide. Shake vigorously for several minutes and occasionally during the ½ to 1½ hour waiting period. A reddish-blue color indicates toluene.

(c) Determination of xylene. Nitrate 0.5 ml of the sample by treating it with 1 ml of concentrated nitric acid and 2 ml of 100% sulfuric acid while shaking vigorously in a hood; heat to boiling.

Cool the mixture and withdraw 0.1 ml of this acid mixture, and add 1 ml of water. A milky suspension is observed due to the presence of the nitration products of aromatic hydrocarbons. Shake 0.5ml of the suspension with 1 ml of cyclohexanol. Make the solution distinctly alkaline with 2N sodium hydroxide solution and mix thoroughly. The alcoholic layer becomes green, indicating presence of xylene.

Method II. Gas Chromatography Procedure

Object

To determine the aromatic content of a solvent mixture by gas chromatography and ultraviolet spectroscopy.

Theory

It is often desirable to be able to tell exactly which aromatic hydrocarbons are present in a solvent sample. In such cases gas chromatography has proved to be of great value. It is a simple matter to determine the number of volatile compounds in an unknown solvent sample, it is not, however, easy to decide which peaks produced in a chromatogram can be attributed to specific aromatic compounds. A comparison of retention times is one method of identifying peaks. A more specific method, however, of identifying aromatic peaks in a chromatogram is to collect the separated substances as they are eluted from the chromatographic column and use an ultraviolet spectrophotometer for the identification of each compound. The basic requirement for the success of such a method is that the resolution of the compounds be distinct enough so that the fractions may be collected without overlapping. A polar column of 7,8-benzolquinoline can be used for this purpose or a column consisting of 5% diisodecyl-phthalate -5% Bentone 34 is also very useful in resolving aromatic hydrocarbons. For example, both columns are capable of separating the ortho, meta, and para isomers of xylene.

Another factor to consider is the detector. A non-destructive detector should be used or it will be necessary to use a down-stream splitter in order to vent enough material for collection. A suitable collection medium for ultraviolet analysis is isooctane (2,2,4-trimethylpentane).

Equipment and Reagents

1. Gas chromatograph.
2. Ultraviolet spectrophotometer, a recording type is preferred but a manually operated instrument may be used.
3. Column: 7,8-Benzolquinoline or other suitable substrate.
4. Chromatoquality benzene, toluene and xylene
5. 2,2,4-Trimethylpentane (isooctane)
6. Test tubes, small
7. Matched silica photometer tubes
8. Reference ultraviolet spectra
9. Large hypodermic needle
10. Microsyringes

Procedure

Separate all solid material from the solvent sample by filtration. An ultraviolet spectrum should be run on the sample at this stage. The presence of aromatics in the sample can be established usually without separation of other materials. A composite spectrum is obtained for more than one aromatic compound. The sample should then be chromatographed, starting at low column temperatures and working upward in order to minimize the possibility of masking small peaks. Each time the conditions are changed, a few microliters of the sample should be injected and the chromatogram inspected. When ideal conditions are reached, that is, when all the peaks are separated adequately without very long retention times, the eluates should be collected. Add 1 to 2 ml of the 2,2,4-trimethylpentane to a series of small test tubes. Chromatograph about 10 ml of sample at the proper attenuation and number the peaks. The test tubes should be numbered accordingly. Attach a hypodermic needle to

the exit of the chromatograph. As the peaks appear on the chromatogram bubble the effluent gas into the 2,2,4-trimethylpentane using the properly numbered test tube.

To avoid contamination of poorly resolved substances collect only those fractions representing the tops of the chromatographic peaks.

A baseline curve should be run on the ultraviolet spectrophotometer by placing pure isooctane in both reference and sample beams.

Transfer the collected fraction to a matched silica cell and place in the sample beam of the instrument. The ultraviolet spectrum is then obtained.

By comparison of the spectrum with a series of reference spectra, positive identification of the aromatic peaks are made.

A quantitative determination can then be made on the chromatograms by injecting varied amounts of the known compounds into the chromatograph and measuring either the height of the peaks or preferably the areas under the peaks. The standardization should be made in the same concentration range as the samples. Straight line relationships will result when concentrations are plotted against peak areas. The amount of sample components is computed when the respective areas are measured and referred to the standard curves.

Laboratory Exercise - NOISE MEASUREMENT AND ANALYSIS

Object

To measure and evaluate a continuous noise source with the Sound Survey Meter and to measure and evaluate a continuous noise using the Sound Level Meter and Octave Band Analyzer.

b. Octave band analyzer

In making an octave band analysis the output from the Sound Level Meter is fed into an Octave Band Analyzer. The analyzer is equipped with filters which allow only the energy from a selected frequency band to pass through to the analyzer amplifier, attenuator, and meter.

Theory

a. Sound survey meter

Sound pressures are converted by the microphone to an electrical current. This current is amplified and the sound pressure level is indicated on a root-mean-square meter in decibels re 0.0002 dynes per sq. cm. Amplification is controlled in 10 decibel steps by an attenuator. The "A" and "B" weighting networks reduce the electrical response of the unit in certain frequencies, thereby approximating the response of the human ear. The "C" weighting network gives an essentially flat response. The readings obtained from these three weighting networks can be used.

Equipment - Measurements with Sound Survey Meter

1. Sound survey meter
2. Acoustical calibrator
3. Noise sources

Procedure - Measurement with Sound Survey Meter

Check the batteries on the survey meter. Using the acoustical calibrator, calibrate the survey meter. Take measurements of the background noise in the room, obtaining readings on the "A", "B", and "C" networks. Repeat the measurements for other noise sources provided for the laboratory.

Source

Overall level (dB)

A	B	C	C - B	C - A
_____	_____	_____	_____	_____
_____	_____	_____	_____	_____
_____	_____	_____	_____	_____

Equipment - Octave Band Analysis

1. Sound level meter
2. Octave band analyzer
3. Acoustical calibrator
4. Noise sources

Procedure - Octave Band Analysis

Check the batteries in both the sound level meter and octave band analyzer. Adjust the sound level meter to the proper reading, using the acoustical calibrator. Connect the output of the sound level meter into the input of the octave band analyzer. With the analyzer attenuator in zero position and the band selector in the 20 - 10 Kc position, the octave band analyzer meter

Prepared by: Herbert H. Jones

is adjusted to read the same level as the sound level meter. The calibrator is removed and the noise source is turned on. The sound level meter attenuator is moved to produce a reading on the indicating meter and this level (the sum of attenuator setting and indicating meter) is recorded as overall level. The octave band analyzer selector switch may then be moved to the various octave bands. In each band position the attenuator switch of the

analyzer is adjusted to bring the analyzer meter on scale and the level is recorded on the data sheet (Figure 2).

Calculations

Plot the values obtained for each octave band on the graph (Figure 1). Normally these points are connected with straight lines between consecutive octave bands.

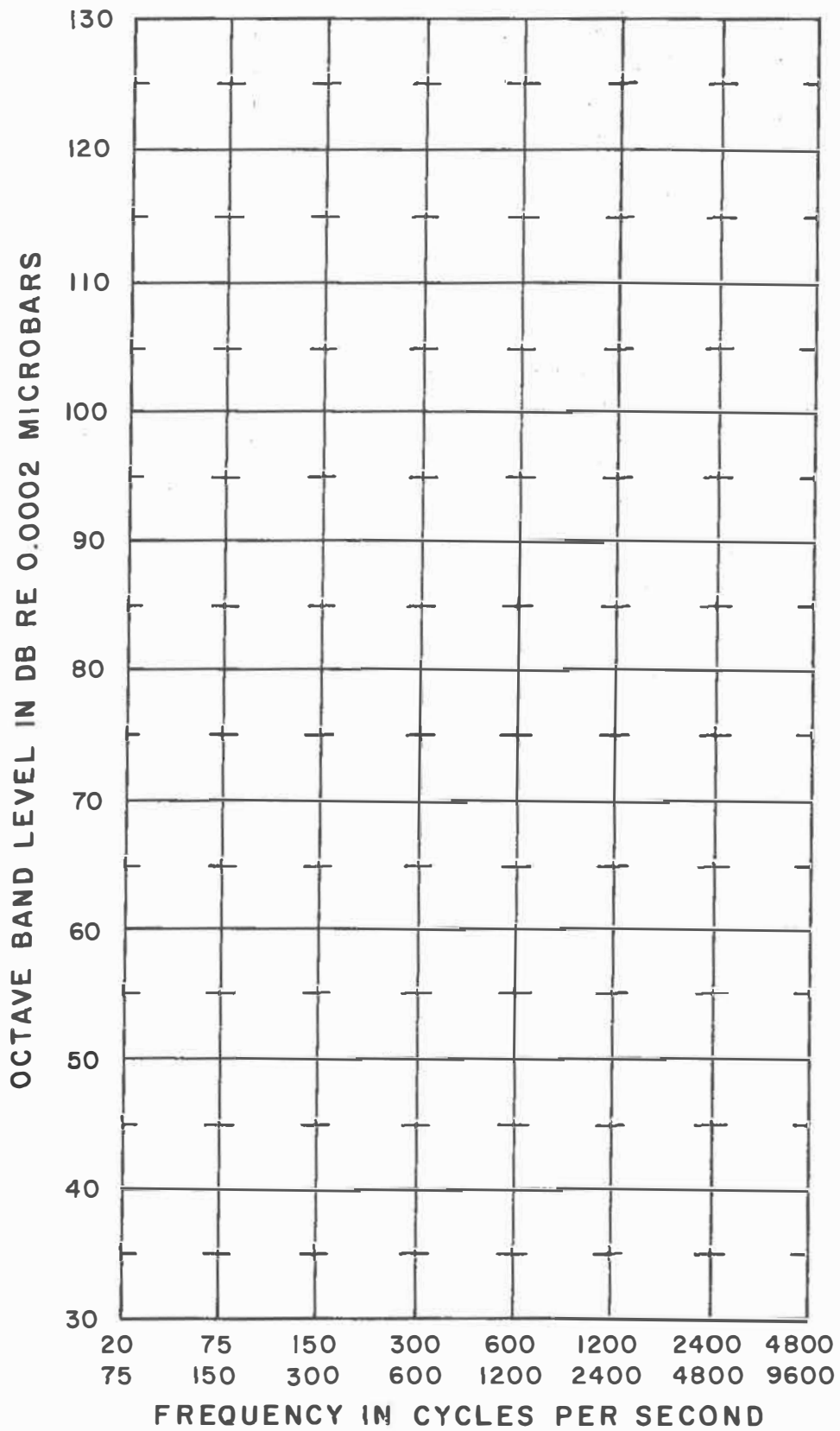

Figure 1

SOUND SURVEY

Page ____ of ____

Plant _____ Dept. _____ Date _____

Sound Level Meter No. _____ Microphone No. _____ Cable _____ Octave Band Analyzer No. _____

Calibrator No. _____ Cal. Start _____ Finish _____ Recorded by _____

Location Number	Meter Speed	Time	Overall Level	Octave Band Level re 0.0002 Microbars								Overall Level	Remarks	
				20	75	150	300	600	1200	2400	4800		Source-speed of operation Type noise - Time pattern	
				75	150	300	600	1200	2400	4800	9600			

E-25-4

Figure 2

(Show sketch of location on back of sheet)

Laboratory Exercise — MEASUREMENT OF ILLUMINATION

Object

To become familiar with methods and techniques for making illumination studies of the work environment.

Theory

The real and one ultimate objective of good illumination in the industrial environment is to provide adequate visibility and satisfactory eye comfort. Poor illumination does cause eye fatigue resulting in decreased production, more rejects of finished products, and increased accidents. It also affects the morale of the workers and lends to poor housekeeping practices.

The four fundamental factors that determine quantity of illumination are: (1) size of the object, (2) time available to perform the task, (3) contrast (brightness ratio) and (4) brightness level to which object is illuminated. The quality factors of illumination include color, direction, brightness, brightness ratio (contrast), diffusion, uniformity of distribution, and glare (direct and reflected). All these factors have significant effects on visibility and the ability to see easily, accurately and quickly. Another important factor is the frequent maintenance of the lighting equipment and periodic cleaning of skylights, windows, room surfaces, etc.

Quantity of light or amount of luminous flux is measured in "lumens." Illumination is measured in "footcandles" and refers to the intensity of light received on the surface. The footcandle is one lumen per square foot. Brightness (or luminance) is measured in "footlamberts." Reflectance is measured

in percent.

Equipment

1. Foot candle meter
(color and cosine corrected)
2. Mirror
3. Shiny metal surface
4. Dull metal surface
5. Cardboard (white, grey & black)
6. Aluminum foil
7. Plastic sheets
8. Yard stick

Procedures

I. Illumination, Transmittance and Reflectance

A. Illumination is measured at the task level or 30 inches above the floor. Divide a desk or laboratory table into approximately ten equal areas. Place the light meter at the center of each area and record the scale readings on the footcandle meter. Do not shade the light sensitive cell while readings are being taken. Add the readings and divide by the number of areas. This result is the average illumination, in footcandles. Measure the length and width of the table in feet and calculate the number of lumens falling on the surface. Lumens = average illumination (footcandles) x area (sq. ft.).

B. Place the light meter on a table exposed to an illumination such that the pointer on the meter is deflected to the upper part of the scale. Record this reading. Place translucent samples over the meter cell and again read the meter. The percent transmittance is calculated from the following equation:

$$\text{Percent transmittance} = \frac{\text{reading with the cell covered}}{\text{reading with cell uncovered}} \times 100$$

C. Place a square sample of paper in a vertical position and measure the illumination falling upon the surface. Record this reading, then point the cell face of the meter toward the sample, drawing it

away from the sample from 3 to 5 inches, until the meter reading is approximately constant. Note this reading and solve the following equation to determine the percent reflectance:

$$\text{Percent reflectance} = \frac{\text{reading with cell toward sample}}{\text{reading with cell away from sample}} \times 100$$

This method of measurement of the reflectance of the surface gives only approximate answers.

Prepared By: E. Elbridge Morrill, Jr.

II – Inverse Square Law and Brightness

A. A lamp has been placed at one end of a measuring stick. Place the light meter two feet from the lamp. Darken the room. Note the illumination reading. Now calculate what the illumination should be 3 feet away from the lamp using the inverse square law. Illumination at 3 feet = illumination at 2 feet $\times \frac{2^2}{3^2}$. Is your reading $\frac{4}{9}$ of the reading at 2 feet.

B. Place the sample of translucent material in a vertical position 3 feet from the light source. The illumination at this point has been measured in the first part of this laboratory activity so the illumination incident on the sample is known. The transmittance is also known from previous works therefore the brightness of the surface away from the source material can now be calculated:

Brightness (in footlamberts) =
illumination in footcandles \times percent transmittance
or reflectance

100

Why is it important to have the ceiling painted with a high reflectance paint? Were your readings accurate? What are possible sources of error?

III – Reflection, Transmittance and Glare

There will be no participation by the student during this activity. The instructor will demonstrate reflection characteristics of materials and translucent characteristics, as well as the effects of direct and reflected glare at the task and in the environment.

IV – Visual Size

There are two vertical lines about 6 feet apart on the chalk board at the front of the room. Stand at marker "A". With both hands, hold the yardstick horizontally in front of you at arms length. Sight over the yardstick to the two lines at the front of the room. Record the distance between the lines as measured with the yardstick held in this position. This is measurement "A". Repeat procedure at marker "B" obtaining measurement "B".

How many times larger is B than A? This represents the increase in visual size because of shorter viewing distance. Getting closer to the object being viewed results in better visibility. Are there any other situations where visual size is important?

V – Lighting Survey

Time will not permit a measurement of the reflectance of walls, ceilings, floors, desk tops, etc. in the room to be studied. Make a rough sketch

of the room to be surveyed; include thereon the approximate dimensions and locate on this sketch the tables, desks and other furniture fixtures on the floor in the room. Make a series of footcandle readings throughout the room and indicate on the sketch the average reading obtained for various areas within the room keeping in mind the tasks to be performed in this room. From the IES Handbook determine if the illumination noted meets the standards. If not, make recommendations where additional lighting luminaires are needed and include the recommended levels of illumination (footcandles).

In making a lighting study of existing lighting conditions one should:

1. Make a plan drawing of the area to scale if possible.
2. Indicate on the drawing – sources of illumination (artificial lighting and daylight). Type of luminaires, number of lamps per luminaire, rated wattage of lamps and mounting height of fixture.
3. Indicate what tasks are being performed and where, such as on tables, machines, desk tops, etc.
4. After making light intensity measurements and measuring the reflectance of walls and ceiling insert these readings on the drawing showing where measurements were made.
5. Include the type of meter used, condition of lighting equipment and surfaces, code to type of lighting fixtures, i.e., 2 or 4 lamp/fixture. These can be footnotes.
6. Include recommended levels of illumination and give source such as IES Handbook.
7. A separate narrative report should be included describing briefly the type of work performed, number of workers for each task, what environmental factors were observed such as shielding omitted, glare conditions, color of walls, ceiling, etc. Then include the findings (light measurements) along with recommendations, which in addition to increase of illumination may also consider relocation of light sources or the task itself, maintenance of lighting equipment, repainting surfaces, etc.

Calculations

The following steps should be followed to solve a general lighting problem by the Lumen method.

Step 1. – From the IES Handbook determine the required level of illumination in footcandles.

Step 2. – Select the lighting system and luminaires. Lighting systems are classified as: –direct, semi-

direct, general diffuse or direct-indirect, semi-indirect and indirect. Offices are best lighted by an indirect, semi-indirect or direct-indirect system. Manufacturing areas usually employ a direct or semi-direct system. The choice of just which of the lighting systems and luminaires best suit a given application will depend upon the seeing task to be performed.

Step 3. - Determine the coefficient of utilization (C.U.). The coefficient of utilization is the ratio of the lumens reaching the working plane (task level or 30" above the floor) to total lumens generated by the lamps. The C.U. takes into account the efficiency

and distribution of the luminaire, its mounting height, the room proportions and the reflectance on walls, ceiling and floor.

The C.U. is obtained from tables in lighting handbooks of commercial producers of lighting equipment. To determine the appropriate C.U. the room ratio or room index (which takes into consideration the room proportions and mounting heights) must be found in tables of lighting handbooks or be calculated. Some methods of calculation are:

For direct, semi-direct, direct-indirect and general diffuse luminaires:

$$\text{Room Ratio} = \frac{\text{width} \times \text{length}}{\text{mounting height above work plane} \times (\text{width} + \text{length})}$$

For semi-indirect and indirect luminaires:

$$\text{Room Ratio} = \frac{3 \times \text{width} \times \text{length}}{2 \times \text{ceiling height above work plane} \times (\text{width} + \text{length})}$$

Step 4. - Estimate the Maintenance Factor (M.F.). The M.F. takes into consideration the cleaning cycle, the relamping practice and ease of access or ability to disrupt work in an area and possibly other con-

siderations. A good M.F. is about 70 or 75%.

Step 5. - Calculate the number of lamps and luminaires required.

$$\text{Number of lamps} = \frac{\text{Footcandles} \times \text{area}}{\text{lumens per lamp} \times \text{coefficient of utilization} \times \text{maintenance factor}}$$

$$\text{Number of luminaires} = \frac{\text{Number of lamps}}{\text{lamps per luminaire}}$$

For fluorescent fixtures use 4 lamp units for jobs over 75 footcandle requirements and 2 lamps

for jobs requiring 75 footcandles or less.

References:

1. Staley, K.A.: Fundamentals of Light and Lighting, Large Lamp Department, General Electric, Bulletin LD-2, August, 1960.
2. _____, Lighting Handbook, Revised Ed., Lamp Division, Westinghouse Electric Corp., Bloomfield, N.Y., March, 1963.
3. _____, How to Make a Lighting Survey, Illuminating Engineering, 58:87-100, February, 1963.

Laboratory Exercise - EVALUATION OF HEAT STRESS

Object

To familiarize the student with the equipment and procedures used to evaluate heat stress in the working environment.

Theory

The industrial hygienist is frequently called upon to evaluate environmental conditions in a plant in terms of the heat stress which will be experienced by the workers. The four environmental factors which influence heat stress are air temperature, humidity, air velocity and radiant heat intensity.

A number of schemes have been proposed for evaluating heat stress; seven of these are discussed in Section B-29 of the Syllabus. Some or all of the above mentioned environmental factors are employed in each of the methods of heat stress evaluation, and in some cases these are combined with physiological factors such as metabolic heat production.

Field measurements of the various factors involved are usually made as outlined below:

1. *Air temperature and humidity* are usually determined from the dry-bulb and wet-bulb readings taken with a psychrometer. In using this instrument, the precautions discussed on pages B-29-5 and B-29-6 of the Syllabus should be observed. If a numerical value of humidity is required, it can be obtained from a psychrometric chart or table.

2. *Air velocity* should be measured with some non-directional type of anemometer. This is important because the direction of air movement in most enclosures is quite random. Heated

thermocouple, hot wire, or heated thermometer type anemometers are usually satisfactory.

In most cases the measured air velocity should be corrected to compensate for the additional velocity created by the activity of the worker. In general, as the work rate increases, the workers' movements and the air velocity correction increase. However, considerable judgment must be used by the investigator. The following table¹ may serve as a guide in making air velocity corrections. The values given in the table are to be added to the measured velocity of the ambient air.

Activity	Air Velocity Correction (fpm)
Sleeping	0
Lying awake	20
Sitting still	20
Standing still	30
Desk work	50
Occasional stroll	100
Walking 2 mph	200
Walking 3 mph	300
Walking 4 mph	400

3. The globe thermometer reading is used as an indication of *radiant heat intensity*. If desired, the mean radiant temperature (MRT) at a given work site can be calculated from the globe temperature and the air velocity. The equations for this calculation, and a description of the globe thermometer are given on page B-29-6 of the Syllabus. Fifteen to 25 minutes are usually required for the globe temperature to reach equilibrium.

4. The measurement of *metabolism* requires special skills and equipment, and it is seldom done in the field. The following table² will be helpful in estimating the metabolic rate of the average man at various work rates.

Prepared by: Clark M. Humphreys

<u>Activity</u>	<u>Metabolic Rate Btu/hr.</u>
Seated, at rest	390
Standing, at ease	430
Seated, very light work	450
Moderately active office work	475
Walking, 2 mph	760
Light bench work	800
Moderate dancing	900
Walking, 3 mph	980
Walking, 4 mph	1400
Heavy work	1500
Maximum exertion	3000 - 4000

Equipment

1. Psychrometers, aspirated and sling
2. Globe thermometer and supporting stand.
3. Thermal anemometer
4. Heat stress chamber (will be discussed in lab.)
5. Charts - Psychrometric, Effective Temperature, Heat Stress Index. All of these will be found in Section B-29 of the Syllabus.

Procedure

1. Using the instruments provided, measure the dry-bulb, wet-bulb, and globe temperatures and the air velocity

at a designated location in the heat stress chamber.

2. From the data gathered in 1 above, determine the heat stress index, the normal effective temperature, the effective temperature corrected for radiation, and the relative humidity.

The corrected effective temperature is determined by the following procedure:

- a. On the psychrometric chart locate the intersection of the observed dry-bulb and wet-bulb temperature lines.
- b. From this intersection move horizontally (at constant specific humidity) to a dry-bulb temperature equal to the observed globe temperature.
- c. At the intersection of the horizontal line and the globe temperature line, read the wet-bulb temperature. This may be termed the "pseudo wet-bulb."
- d. From the effective temperature chart determine the E.T. using the globe temperature as the dry-bulb, the pseudo wet-bulb temperature, and the corrected air velocity. This will be the E.T. corrected for radiation.

The following sketch illustrates the method of determining the pseudo wet-bulb

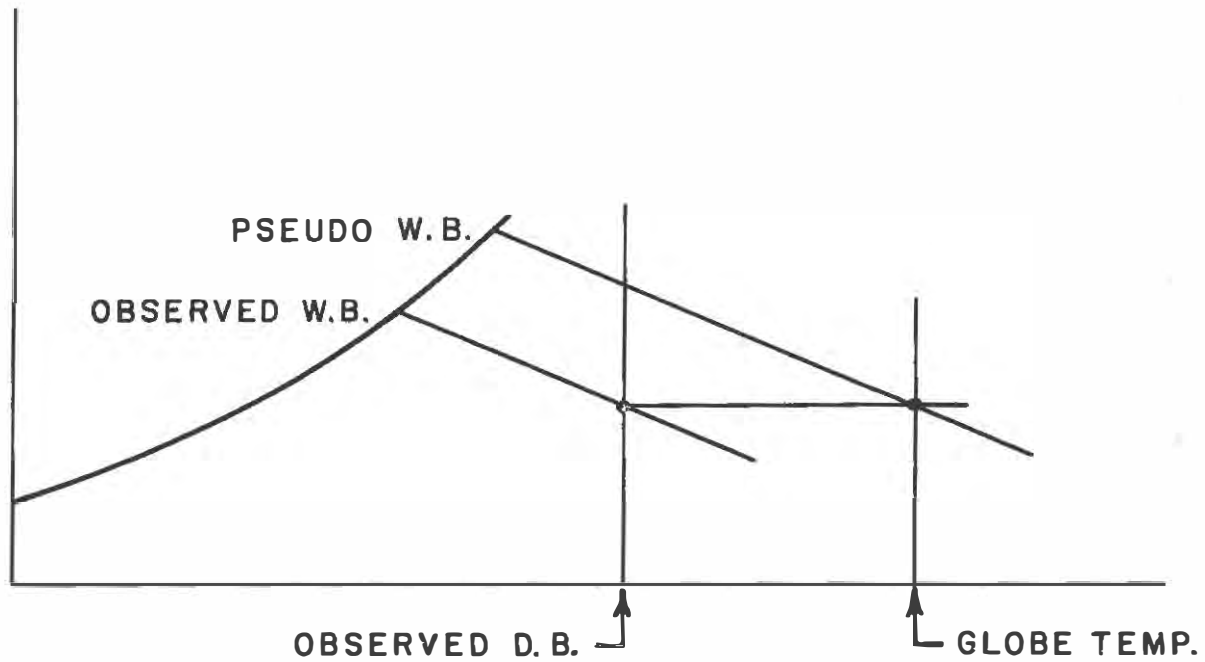

References

1. Lee, D.H.K., and Austin Henschel, "Evaluation of Thermal Environment in Shelter," TR-8, U.S. Public Health Service, Division of Occupational Health.
2. ASHRAE Guide and Data, Fundamentals and Equipment, 1965-66, American Society of Heating, Refrigerating and Air-Conditioning Engineers, and Haines, G.F., Jr., and Theodore Hatch, "Industrial Heat Exposures - Evaluation and Control," Heating and Ventilating, Nov. 1952.

Data Sheet

Dry-Bulb _____ °F

Wet-Bulb _____ °F

Globe _____ °F

Ambient Air Velocity _____ fpm

Air Velocity Correction _____ fpm

Effective Air Velocity _____ fpm

Metabolic rate for assumed work rate _____ Btu/hr.

Results

Heat Stress Index (H.S.I.) _____

Normal Effective Temperature _____ deg.

E.T. corrected for radiation _____ deg.

Relative humidity _____ %

Laboratory Exercise – DETERMINATION OF AVERAGE AIR VELOCITY IN A DUCT

Object

To become familiar with the use of the pitot tube and the procedures used to determine the average air velocity in a duct.

Theory

The pitot tube consists of two concentric tubes—an impact tube whose opening faces axially into the flow, and an outer tube with circumferential openings. The inner tube measures total pressure and the outer tube measures static pressure. By connecting the pitot tube across a manometer, one may determine the velocity pressure of the fluid stream (1 and 2). By Bernoulli's theorem:

$$\text{Velocity} = \sqrt{2gh}$$

Where: Vel. = fps

h = ft. of flowing fluid

g = 32.2 fps²

When using a water manometer we have:

$$h = \frac{h'}{12} \left(\frac{S_o}{S} - 1 \right)$$

Where: h' = manometer reading (in. of H₂O)

S_o = Sp. Wt. of H₂O (62.4 #/ft³)

S = Sp. Wt. of Air (.075 #/ft³)

h = vel. head (ft. of air)

Converting "g" to fpm², and substituting appropriate values, we obtain:

$$\text{Velocity (fpm)} = 4005 \sqrt{h'}$$

By dividing a duct into a series of concentric circles, each of which represents an equal area, measuring the velocity pressure at an equal distance between each succeeding circle, and making a traverse across and then at 90° intervals to the original traverse, one can determine the "profile" of the velocity in the duct. From these velocities an average velocity can be calculated. It is important to note that:

$$\text{Vel}_{\text{avg}} = \frac{\sum \text{Vel}}{n} \neq \frac{\sum \text{V.P.}}{n}$$

Where: n = number of readings taken

A pitot tube used according to instructions will give accurate and precise readings. In order to elongate the manometer scale and give more accuracy, an inclined manometer is often used.

Other devices, such as the Velometer and its attachments, can be used to determine the air velocity in a duct; however, accurate results will depend upon the instrument calibration.

Procedure

1. Make a 10 point vertical traverse and a 10 point horizontal traverse using the pitot tube. (For points in the traverse for different duct sizes, see Ind. Vent. p. 9-4)⁽¹⁾
2. Calculate the velocity for each point and determine the average velocity. Do not average velocity pressures.
3. Make a pitot tube reading at the center of the duct. Nine-tenths of the velocity at this point should approximate the average velocity.
4. Plot a profile for the velocity for both the horizontal and vertical traverse.
5. By use of the manometer and pitot tube, determine in one reading the total pressure and by another reading the static pressure. (This may be done by removing the correct tube from the manometer.)

Equipment

Pitot tube
Manometer or Inclined Gauge
Tubing

Calculations

Pitot Traverse

" Duct Reading Point Inches	Horizontal		Vertical	
	Manometer h " H ₂ O	Velocity fpm	Manometer h " H ₂ O	Velocity fpm
1				
2				
3				
4				
5				
6				
7				
8				
9				
10				
Total	- - - - -		- - - - -	
Avg. Vel.	- - - - -		- - - - -	

At Centerline:

VP =
SP =
TP =

Vel. = × 0.9 = fpm

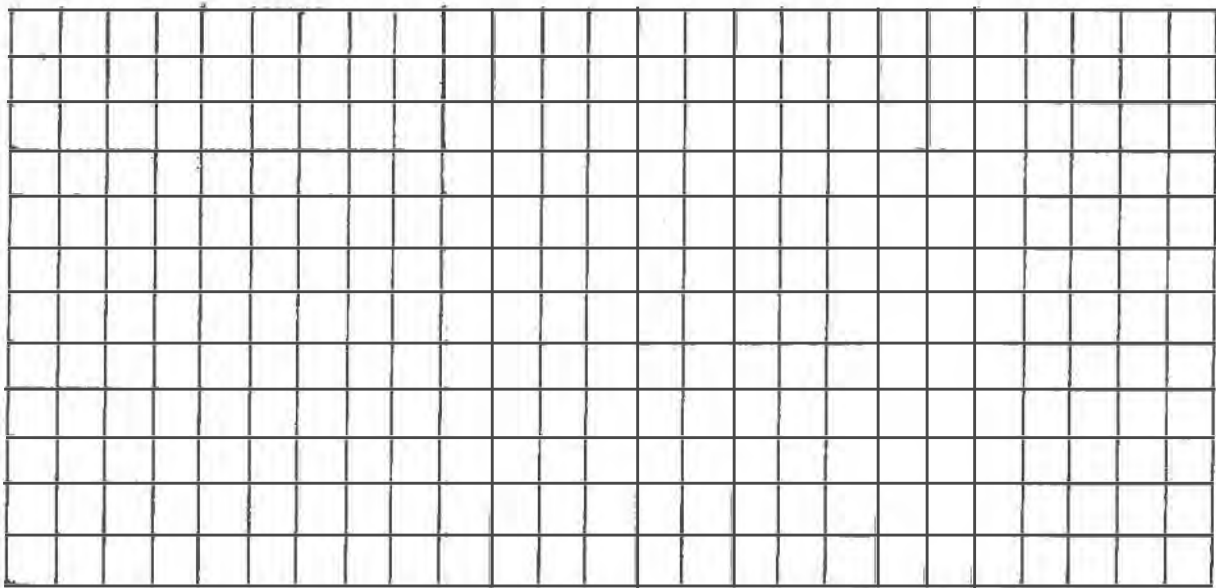

References:

1. _____:Industrial Ventilation - A Manual of Recommended Practice. ACGIH Committee on Industrial Ventilation, Lansing, Michigan, 8th Ed., 1964.
2. Powell, C.H. and A.D. Hosey, Ed.: The Industrial Environment - its Evaluation and Control, Division of Occupational Health, U.S. Public Health Service, Publication No. 614, 2nd. Ed., U.S. Government Printing Office, Washington, D.C. 1965.

Laboratory Exercise - MEASUREMENT OF PRESSURE LOSSES IN DUCTWORK

Object

To become familiar with the various head losses in a duct system, and to observe good and bad practices in duct design.

Theory

The various losses in a duct system are discussed elsewhere and in Chapter VI of the manual on Industrial Ventilation.

Equipment

Manometer or magnehelic gauge.

Procedure

1. Loss in straight duct section:

Measure the pressure drop between two taps located a measured distance apart in the straight duct. Calculate the pressure loss per 100 feet.

Calculations

2. Loss in an elbow:

Measure the pressure drop between two taps on either side of the elbow. Using the pressure drop per 100 feet previously determined, subtract the drop caused by friction in the straight duct. The difference is the elbow loss.

3. Loss in a tee:

Measure the pressure drop across the tee from both upstream points. Estimate the friction loss in straight duct in both cases. The differences are the losses in both branches.

4. Loss in an enlargement:

Measure the pressure difference across the enlargement.

$$\text{Regain} = \frac{SP_2 - SP_1}{VP_1 - VP_2}$$

$$\text{or loss} = (1 - R)(VP_1 - VP_2)$$

5. Compare values found with those in the manual.

Straight Duct

Δp (inches H ₂ O)	Distance (ft.)	Flow (cfm)	$\Delta p/100$ ft.	
			obs.	chart

Elbow

Total Δp (inches)	St. Duct (ft.)	$\Delta p/100$ ft.	Duct loss	Elbow loss	
				inches	% of v.p.

Tee

Right angle branch				Straight branch			
Δp	Duct loss (inches)	Tee loss		Δp	Duct loss (inches)	Tee loss	
		inches	% of branch v.p.			inches	% of branch v.p.

Enlargement

Static pressure		Velocity pressure		Regain	Loss
(downstream)	(upstream)	(upstream)	(downstream)		

Laboratory Exercise — EFFECT OF HOOD FLANGES ON COEFFICIENT OF ENTRY.

Object

To become familiar with and demonstrate hood characteristics such as hood static suction, coefficient of entry C_e and hood entry losses h_e caused by flanging a simple pipe end, and the relationship between these quantities.

Theory

For an opening with no entry loss, such as a well-rounded bell mouth, the velocity immediately downstream from the hood is given by the equation $V = 4000\sqrt{h_s}$, where h_s is the hood static pressure in inches of water and V is velocity in ft/min. Most hoods have an entry loss, however, so that a coefficient of entry (C_e) must be used, and $V = 400 C_e \sqrt{h_s}$. If the average velocity in the pipe is determined by a Pitot traverse, and the static suction is measured with a manometer, the coefficient of entry can be calculated (1 & 2).

$$C_e = \frac{V}{4000\sqrt{h_s}} = \frac{\sqrt{v.p.}}{\sqrt{h_s}} \quad \text{where } v.p. \text{ is the velocity}$$

pressure determined by Pitot tube. The hood entry loss (h_e) is that part of the hood static suction which is not converted into velocity pressure. Thus:

$$C_e = \frac{\sqrt{v.p.}}{\sqrt{v.p. + h_e}} = \frac{\sqrt{VP}}{\sqrt{SP}}$$

$$C_e^2 (v.p. + h_e) = v.p.$$

$$h_e = \frac{v.p. (1 - C_e^2)}{C_e^2}$$

Calculations

Equipment

1. Pitot tube
2. Magnhelic gages
3. Thermoanemometer
4. Rubber tubing
5. Tape or yardstick
6. Smoke tubes

Procedure

1. Open end duct:
 - a. Measure velocity pressure at the center line with a pitot tube and calculate VP average and V average.
 - b. Measure hood static suction with a magnhelic gage. 1 to 3 diameters downstream from the duct end.
 - c. Calculate Q (cfm)
 - d. Calculate and measure the capture velocity at a point 6" in front of the duct.
 - e. Calculate the hood entry loss and the hood entry coefficient.
 - f. Determine the hood entry coefficient from Figure 6-5 of ventilation manual (1).
2. Repeat measurements and calculations for airflow in cfm, capture velocity, hood entry loss, and hood entry coefficient for a flanged end duct, tapered hood, straight and tapered booth take off.
$$V = 4000 \sqrt{v.p.}, \text{ and } V_{av} = 0.9 V \text{ CL}$$

assume $v.p. av. = 0.81 v.p. CL$ for duct end with and without a flange.
3. Using a smoke tube, note the relative degree of control with and without a flange.

References:

1. _____: Industrial Ventilation - a Manual of Recommended Practice. ACGIH Committee on Industrial Ventilation, Lansing, Michigan, 8th Ed., 1964.
2. Powell, C.H., and A.D. Hosey, Ed.: The Industrial Environment - its Evaluation and Control, Division of Occupational Health, U.S. Public Health Service, Publication No. 614, 2nd Ed., U.S. Government Printing Office, Washington, D.C. 1965.

**HOOD CHARACTERISTICS WORKSHEET
DEMONSTRATION SYSTEM**

Hood Type	Open End Duct	Flanged Duct	Tapered Hood	Booth St. Take Off	Booth Tapered Take Off
VP _{CL} (Pitot) (Inches H ₂ O)					
VP _{avg} = 0.81 VP _{CL} (Inches H ₂ O)					
V _{avg} (VP/V Table p6-26) (1) (FPM)					
SP at hood (Inches H ₂ O)					
Q = AV = 0.136V for 5" duct (CFM)					
Formula for V (X less than 1½ D)	$\frac{Q}{10X^2 + A}$	$\frac{Q}{0.75(10X^2 + A)}$	$\frac{Q}{10X^2 + A}$	$\frac{Q}{10X^2 + A}$	$\frac{Q}{10X^2 + A}$
V _{6"} Calculated (FPM)					
V _{6"} Measured (FPM)					
h _e = SP - VP (Inches H ₂ O)					
C _e = $\sqrt{\frac{VP}{SP}}$					
C _e from Fig. 6-5 (1)					

Prepared by: M.E. LaNier & B.S. Pearson, 1965

Laboratory Exercise - MEASUREMENT OF SLOT AND SURFACE VELOCITY AND ENTRANCE LOSS

Object

To become familiar with the meaning of "entry loss," "static suction", "velocity pressure" by measuring or calculating these values; to note the method of estimating entry loss for a hood; and to compare the measured and estimated values.

Theory

Whether a well-designed hood controls a contaminant is dependent primarily on the quantity of air exhausted. It is often difficult to measure directly the quantity of air flowing through a hood after installation. If the entry loss of a hood is known, the airflow can be estimated by measuring the "hood suction."

The hood suction is the static pressure immediately (1 - 3 pipe diameters) downstream from the hood. It is the sum (ignoring sign) of the velocity pressure (v.p.) and the entry loss (h_e). Velocity pressure can be determined by the formula

$$V = 4005 \sqrt{v.p.} \text{ or } v.p. = \left(\frac{V}{4005} \right)^2$$

where V is velocity in feet per minute and v.p. is pressure in inches of water. In this experiment we find the airflow (Q) by other means and use the relationship

$$V = \frac{Q}{A}$$

to obtain velocity.

Hood entry loss is the sum of the individual losses through the hood. For a slotted tank it may be considered as the sum of the loss through a sharp-edged orifice and an entry with an angle of 90° . The formula given for entry loss under these conditions is:

$$h_e = 1.3(\text{slot v.p.}) + 0.25(\text{duct - v.p.})$$

The particular tank used in this experiment has an entry loss less than predicted by the formula, probably because the take-off from the slot is more favorable than in most industrial installations.

Equipment

1. Velometer or thermoanemometer
2. Manometer or magnehelic gauge
3. Smoke tubes

Procedure

1. Using a velometer or thermoanemometer adjust slot opening so that slot velocity is 2000 fpm. Measure slot area and estimate airflow through slot.

2. Using thermoanemometer and smoke tube check surface velocities and effectiveness of control.

3. Using measurements of total airflow and airflow through the other branch made by groups one and three respectively, determine airflow through tank hood by difference. Calculate velocity pressure.

4. Measure static suction one diameter downstream from hood.

5. Calculate coefficient of entry, C_e and hood entry loss, h_e , using formulae in 8th Ed. ACGIH Industrial Ventilation Manual, Section 4, page 6, 1964.

6. Calculate the expected entry loss and coefficient of entry from the formula under Theory and the relationships on p. 4-6 of ACGIH Industrial Ventilation Manual 8th, 1964. Compare with actual values.

Calculations

Slot area = estimated airflow =

2000 x slot area =

Airflow

Total	Through 6" duct	Through hood

$$\text{Static suction} = C_e = \sqrt{\frac{VP}{SP}} = h_e$$

$$= \frac{(1 - C_e^2) VP}{(C_e)^2} =$$

Expected entry loss (h_e) =

1.3 (slot v.p.) + 0.25 (duct v.p.)

$$\text{Expected } C_e = \frac{\sqrt{\text{duct v.p.}}}{\sqrt{\text{v.p.} + h_e}}$$

Laboratory Exercise - DETERMINATION OF CHARACTERISTICS OF AIR JETS

Object

To demonstrate some of the characteristics of discharge jets which are important in the field of comfort ventilation, mine ventilation, and push-pull systems.

Theory

As an air jet issues from a supply source, it is placed in contact with stationary air. The air at the edges of the jet entrains more and more of this stationary air by turbulent mixing, so that the velocity of the jet is constantly decreasing, while the area is increasing. The theory of free air jets is given briefly in Hemeon⁽¹⁾, using data from several sources. For a round jet the characteristics are described in terms of two phases. Using V_{max} as the maximum (centerline) jet velocity at a distance X , and V_o as the maximum outlet velocity:

For the first phase, which extends out 5 diameters,

$$(1) \frac{V_{max}}{V_o} = 1.0 \text{ to } 1.2$$

For distances greater than 5 diameters,

$$(2) \frac{V_{max}}{V_o} = \frac{K}{X/D}$$

Calculations

Distance from outlet		Velocity (fpm) Measured	$\frac{V_x}{V_{max}}$ 2.7	K	V_{max} Calculated
Feet	Diameters				

where X is distance and D is diameter of outlet.

The table below gives values of K

V_x (fpm)	Maximum outlet velocities (fpm)		
	1000-	3000-	5000
2000	4000	4000	4000
Values of K			
180	6.0	6.3	6.8
150	5.6	6.1	6.5
100	5.1	5.6	6.0
75	4.7	5.1	5.4
40	3.7	3.9	4.0

Note: $V_x = \frac{V_{max}}{2.7}$

An average K value of 6 may be used for approximations.

Equipment

1. Vane Anemometer
2. Ringstand
3. Tape or yardstick
4. Stopwatch

Procedure

Using the vane anemometer and stopwatch, measure the centerline velocity at 0, 1, 2, 5, 10, 20, and 30 diameters from the outlet.

Reference

1. Hemeon, W.C.L.: Plant and Process Ventilation. Industrial Press, New York, 2nd Edition, 1963.

Laboratory Exercise - FLOW THROUGH GRILLES

Object

To demonstrate the techniques for determining airflow through grilles.

Theory

The determination of the airflow in cfm across the face of a grille by the use of a velocity meter to determine airflow through the effective area of the opening in grille by $Q = KAV$.

Equipment

Alnor Velometer
Alnor Jr.
Rotating Vane Anemometer
Heated Wire or Thermocouple Anemometer
Stopwatch
Ruler

Procedure A

1. Determine with a smoke tube the airflow characteristics through the grille.
2. Divide the grille into areas of similar size and airflow characteristics.

Calculations

3. Calculate the effective area of the grille.

4. Measure the air velocity in each of these areas with the swinging vane velometer and the heated wire anemometer. Calculate the airflow considering the average velocity, area and correction factors by:

$$Q = \sum [(A_1 \times V_1 \times F_1) + \dots + (A_n \times V_n \times F_n)]$$

Q = airflow in cubic feet per minute (cfm)

A = area in square feet

V = velocity in feet per minute

F = correction factors

(See ACGIH Industrial Ventilation Manual, Section 9).

Procedure B

1. Use the Rotating Vane Anemometer to traverse the face of the grille in a measured period of time to obtain an integrated average air velocity for the grille.

2. Calculate the average face velocity, area of grille, and airflow, considering the necessary correction and calibration factors. (ACGIH Industrial Ventilation Manual, Section 9).

Prepared by: Kenneth J. Kronoveter and
Julius H. Fanney, Jr.

1913 - 1914

Public Health Service Publication No. 614