

# Impact of Environmental Factors on Efficacy of Upper-Room Air Ultraviolet Germicidal Irradiation for Inactivating Airborne Mycobacteria

PENG XU,<sup>†,||</sup> ELMIRA KUJUNDZIC,<sup>†</sup> JORDAN PECCIA,<sup>†,‡</sup> MILLIE P. SCHAFER,<sup>†</sup> GENE MOSS,<sup>#</sup> MARK HERNANDEZ,<sup>†</sup> AND SHELLY L. MILLER,<sup>§</sup>

Department of Civil, Environmental, and Architectural Engineering, 428 UCB, University of Colorado, Boulder, Colorado 80309-0428, The National Institute for Occupational Safety and Health, Centers for Disease Control and Prevention, Public Health Services, U. S. Department of Health and Human Services, 4676 Columbia Parkway, MS R-3, Cincinnati, Ohio 45226-1099, and Department of Mechanical Engineering, 427 UCB, University of Colorado, Boulder, Colorado 80309-0427

This study evaluated the efficacy of an upper-room air ultraviolet germicidal irradiation (UVGI) system for inactivating airborne bacteria, which irradiates the upper part of a room while minimizing radiation exposure to persons in the lower part of the room. A full-scale test room (87 m<sup>3</sup>), fitted with a UVGI system consisting of 9 louvered wall and ceiling fixtures (504 W all lamps operating) was operated at 24 and 34 °C, between 25 and 90% relative humidity, and at three ventilation rates. *Mycobacterium parafortuitum* cells were aerosolized into the room such that their numbers and physiologic state were comparable both with and without the UVGI system operating. Airborne bacteria were collected in duplicate using liquid impingers and quantified with direct epifluorescent microscopy and standard culturing assay. Performance of the UVGI system degraded significantly when the relative humidity was increased from 50% to 75–90% RH, the horizontal UV fluence rate distribution was skewed to one side compared to being evenly dispersed, and the room air temperature was stratified from hot at the ceiling to cold at the floor. The inactivation rate increased linearly with effective UV fluence rate up to 5 μW cm<sup>-2</sup>; an increase in the fluence rate above this level did not yield a proportional increase in inactivation rate.

## Introduction

The transmission of infectious diseases in high-exposure environments such as health-care facilities has been a

\* Corresponding author phone: 303-492-0587; fax: 303-492-3498; e-mail: shelly.miller@colorado.edu.

<sup>†</sup> Department of Civil, Environmental, and Architectural Engineering, University of Colorado.

<sup>‡</sup> The National Institute for Occupational Safety and Health.

<sup>§</sup> Department of Mechanical Engineering, University of Colorado.

<sup>||</sup> Current address: Building Technologies, Lawrence Berkeley National Laboratory, 1 Cyclotron Rd, MS 90-3111, Berkeley, CA, 94720.

<sup>‡</sup> Current address: Environmental Engineering Program, Yale University, PO Box 208286, New Haven, CT 06520-8286.

<sup>#</sup> Current address: Corning Inc., SP-AR-01-1, AR183F, Corning, NY 14831.

recognized hazard for decades. Ultraviolet germicidal irradiation (UVGI) systems are used as an engineering control to prevent transmission of infectious diseases (1). One common application of commercially available UVGI systems is upper-room air irradiation (2). For upper-room air irradiation, germicidal lamps are suspended from the ceiling or attached to the walls; the bottom of the lamp is usually shielded to direct radiation upward above a predetermined height. The objective of this configuration is to maximize UV radiation exposure to airborne microorganisms in the upper part of the room, while minimizing radiation exposure to persons in the lower part of the room. Commercially available germicidal lamps contain mercury vapors under low pressure that emit radiation in the UV–C wavelength range, with about 90% of the total spectral power emitted at 254 nm.

Infrastructure and environmental factors can affect the performance of upper-room air UVGI systems. These factors include room airflow patterns, room relative humidity (RH), UV fluence rates, UV radiation spatial distribution patterns, and photoreactivation. Upper-room air UVGI only irradiates the upper parts of a room; thus, air from the lower part of the room must move into the upper part to be irradiated. Factors influencing airflow patterns include room ventilation supply/exhaust locations and air temperatures. Previous studies of UVGI efficacy were either done in environments where the mixing conditions were uncontrolled or unknown (3–7), or in a room in which the air was well mixed using fans (8).

While mixing conditions within a room affect the UV dose bacteria receive while airborne, a growing body of evidence suggests that relative humidity has a critical effect on bacterial culturability and replication potential. Studies have shown that airborne *Escherichia coli* is more vulnerable to UVGI at high RH (9, 10). Riley and Kaufman reported that the fraction of airborne *Serratia marcescens* inactivated by UVGI declined sharply at RH above 60–70% (11). Peccia et al. showed that UV inactivation rates in vegetative bacteria were sensitive to changes in RH, and were a minimum near saturation (95%) and maximum near 50% RH (12).

Other factors that can change UVGI performance are UV fluence rates and the radiation distribution patterns within a room. UV fluence rate is defined as the radiant power of all wavelengths passing through a sphere (μW cm<sup>-2</sup>). The rate of airborne microbial inactivation increases as the UV fluence rate increases; the range of fluence rates, however, over which such a relationship exists, is not known (8). Like other disinfection responses, there may be some threshold fluence rate above where a saturation behavior exhibits and some lower limit below where there is no detectable effect. Historically, when installing UVGI in a facility, a single UV lamp fixture was hung on one side of an upper wall of a room or from the ceiling (7). The UV fluence rate was then highest on one side of the room nearest the wall fixture or highest near the ceiling fixture.

The factors discussed above can decrease the performance of a UVGI system. Another factor, photoreactivation (PR), can also impact performance by facilitating the recovery of UVGI-damaged genetic material in airborne bacteria. Light-activated DNA photolyase enzymes, which can repair certain types of UV-induced lesions, facilitate this recovery. It has been suggested that short wavelength light, in the near-UV range, is the main factor inducing photoreactivation (13). PR may affect UVGI system performance adversely in environments with incandescent light, fluorescent light, or sunlight.

Previous studies on bacteria suspended in liquid, or on agar plate surfaces, have been conducted showing that PR

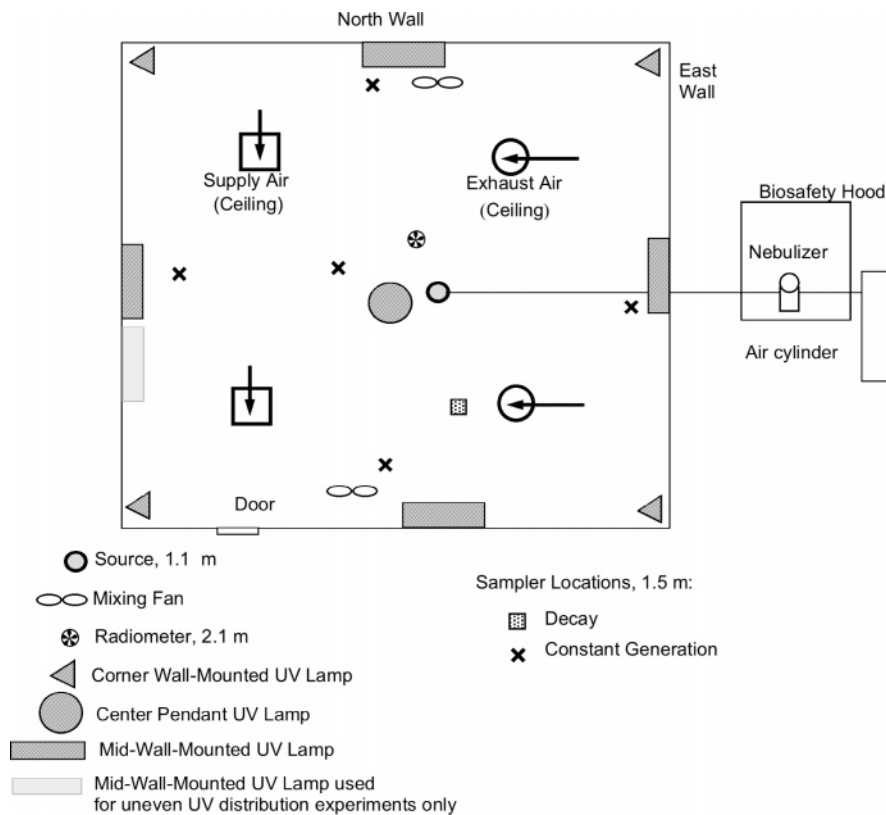

**FIGURE 1. Configuration of 87-m<sup>3</sup> test room (plan view). Heights above the floor are given. Test room was sealed and under slight negative pressure during experiments.**

occurs in *Mycobacterium* spp. (14), and that the length of exposure to photoreactivating light is an important factor affecting the extent of PR (15). Oguma et al. demonstrated that in liquid suspensions of *E. coli* and *Cryptosporidium parvum*, the number of pyrimidine dimers incorporated into their DNA was highly correlated with the dose of UV used, and that the dimers were continuously repaired during exposure to common fluorescent light (16). Oguma et al. also observed that for *C. parvum*, animal infection potential and the PR-induced repair of genetic damage were not correlated.

These studies, however, may not reflect accurately the PR behavior of airborne microorganisms because the hydration states experienced by airborne bacteria are different from those in liquid environments or under culturing conditions. A recent study showed that in a small UV exposure reactor, PR rates of airborne *Mycobacterium parafortuitum* increased with increasing RH and decreasing UVGI dose (17). In a related study, Peccia and Hernandez showed that when irradiated in the absence of photoreactivating light, cyclobutane thymine dimers were not the most significant form of UVGI-induced DNA damage incurred by airborne bacteria, suggesting that other mechanisms of UV-induced damage may be as or more damaging (18). This work confirmed that both the type and extent of UV-induced DNA damage is dependent on RH, at least in pure cultures of commonly tested airborne bacteria.

Data are limited on the effects of environmental factors on upper-room air UVGI system performance at full-scale operation and questions remain about system performance under a broad range of conditions and lamp configurations. Our research group at the University of Colorado observed the performance of a modern UVGI system for inactivating airborne *Bacillus subtilis* spores and vegetative *M. parafortuitum* and *Mycobacterium bovis* BCG (8). All experiments

were conducted in an 87-m<sup>3</sup> reactor at 50% RH and 25 °C under well-mixed room air conditions. The UVGI system configuration evaluated was 216 W total, 4 corner lamps and one center lamp hanging from the ceiling, and was between 46% and 98% effective at reducing the culturability of airborne bacteria depending on the microorganism under study. We also determined that the UVGI inactivation rate for *M. parafortuitum* was  $16 \pm 1.2 \text{ h}^{-1}$  at a system average upper-zone fluence rate of  $42 \mu\text{W cm}^{-2}$ . The average inactivation rate normalized to UV fluence rate, often termed Z value, was  $1.2 \times 10^{-3} \text{ cm}^2 \mu\text{W}^{-1} \text{ s}^{-1}$ .

Not all environments, however, in which UVGI systems are or will be installed operate at moderate constant temperature and RH, nor are they under well-mixed conditions. To better understand how to design and operate UVGI systems under variable field conditions, we extended our study to include those potentially critical effects that environmental parameters may have on the performance of modern UVGI systems. Experiments were conducted under various relative humidities, air mixing conditions, UV fluence rates, and radiation distribution patterns. UVGI efficacy was also assessed in the presence and absence of visible photoreactivating light. Each factor was isolated as a process variable, and individually varied while holding the others constant. This new work both bridges critical knowledge gaps in UV inactivation practice and extends fundamental research and bench-scale experiments to full-scale operations.

## Experimental Section

**Test Facility.** An 87-m<sup>3</sup> room housed inside the Joint Center for Energy Management's Larson Building Systems Laboratory, University of Colorado at Boulder, was used for this study (Figure 1). The room is capable of maintaining temperatures between 15 and 35 °C and relative humidity

between 50 and 100%. This test facility has been previously described (8).

A modern UVGI system (Lumalier, Memphis, TN) is installed in the test chamber and consists of five fixtures: four mounted in each of the corners of the room, and one hung from the center of the ceiling (Figure 1). Four additional fixtures were installed for the purpose of this study: one mounted on each of the walls (Figure 1). The center fixture consists of four lamps. The corner fixtures contain two lamps, and the wall fixtures contain four lamps, each installed with parabolic aluminum reflectors. The lamps within the fixtures (PL-L18W/TUV, Lumalier, Memphis, TN) are each rated at 18 W nominal with 5.5 W UV-C, 254 nm wavelength. Each fixture is equipped with concentric black louvers of 1.9-cm spacing. The height of the fixtures is approximately 25 cm and they were installed so that the lower edge was located 2.1 m above the floor and the top was 10 cm below the ceiling. This placement created a band of UVGI in the upper level of the room, with an average depth of approximately 30 cm. The depth of the band varied throughout the room, with the narrowest dimensions being right next to the lamps at 18 cm and the widest dimensions being between fixtures.

When testing UVGI performance under different air mixing conditions, RH levels, and for photoreactivation experiments, the four corner UV fixtures and the one center fixture were operated at full power, 216 W. For experiments that explored various UV fluence rates and radiation spatial distributions, the UV fixtures were operated at differing power levels based on the test requirements.

For the photoreactivation experiments, full spectrum fluorescent lamps (F40T12SUN, Verilux, Inc., Stamford, CT) were installed in test chamber. Each 122-cm lamp provided 40 W of power and 12 lamps were installed in the test room ceiling-recessed light fixtures. All experiments except those involving photoreactivation were conducted in the dark.

The UVGI system was operated for 100 h before experiments were conducted. The UV fixtures were rated "ozone free" and ozone was not detected in the test room during UVGI operation (tested using a portable ozone monitor (19)).

**Actinometry.** Spherical actinometry was used to characterize the UVGI distribution in the room according to methods developed by Rahn et al. (20). To measure the fluence rate in the upper zone of the room, actinometers were suspended at 20 evenly spaced locations 2.3 m from the floor and exposed to UVGI for 30 min. The actinometric method was also used to measure UVGI in the breathing zone (1.5 m above the floor) by hanging them at 20 locations, and exposing them for 12 h.

Actinometer measurements were made for the corner plus center fixtures (5 fixtures, 216 W total operating lamp power) and for all fixtures (9 fixtures, 504 W total operating lamp power) operating. We also measured the fluence rate for the following configurations: (a) two lamps in three of the corner fixtures, one lamp in the other corner fixture, and two lamps in the center fixture (162 W); (b) one lamp in each of the corner fixtures and two lamps in the center fixture (108 W); (c) a lamp in each of three corner fixtures (54 W); and (d) two wall fixtures and two corner fixtures along the west wall (216 W; an extra wall fixture was installed for this test; see Figure 1).

The UVGI lamps were warmed for at least 30 min before all measurements.

**Culture Preparations.** *Mycobacterium parafortuitum*, a rapid-growing, rod-shaped environmental Mycobacterium that yields pale yellow colonies, was used in this study (American Type Culture Collection (ATCC), Manassas, VA, ATCC #19689). *M. parafortuitum* was grown on soybean-

casein digest agar (SCDA) (Difco Laboratories, Detroit, MI) at 37 °C and incubated for 60 h. Fresh *M. parafortuitum* cultures were removed from agar plate surfaces by scraping, and were suspended in sterile deionized water immediately prior to aerosolization. Cell concentrations were diluted to a concentration of approximately  $1 \times 10^9$  cells mL<sup>-1</sup> as determined by direct microscopy.

**Airborne Bacteria Generation and Collection.** Bioaerosol was generated using a six-jet Collison nebulizer with a large reservoir (CN 25, BGI Inc., Waltham, MA) according to widely accepted methods (6, 8, 21–23). Bioaerosol was released approximately 1.0 m above the floor in the middle of the room between the ventilation exhaust and supply (Figure 1).

Airborne microorganisms were sampled using AGI-30 impingers (AGI-30, Ace Glass Inc., Vineland, NJ) at 12 L min<sup>-1</sup> through tubing connected to a manifold in series with a high-flow sampling pump (model 1023-101Q, Gast Manufacturing Inc., Benton Harbor, MI) regulated by rotameters (model 7400, King Instrument Inc., Garden Grove, CA). The impingers concentrated the bacteria into 30 mL of sterile, 50 mM phosphate buffer saline (PBS) solution (PBS; 150 mM NaCl, pH 7.2) with minimal damage to the microorganisms (24). Before each experiment, the impinger airflow was calibrated using a bubble meter (Gilibrator, Scientific Industries, Bohemia, NY).

**Enumeration by Culturing and Epifluorescent Microscopy.** Following collection, the impingers' contents were mixed and divided into equal aliquots for two types of analysis: culturing of colony-forming units (CFU) and direct counting using epifluorescent microscopy. Within 2 h after collection, air samples from liquid impingers were diluted (usually 1:10) in 50 mM in PBS solution and cultured using a spiral plating method (Spiral Biotech, Inc., Norwood, MD) according to manufacturer's recommendations. All plating was performed in indirect dimmed light (minimal light fixtures were turned on in the laboratory and none of the fixtures that were on were directly overhead). At least three replicates of each sample were plated on SCDA agar and incubated in the dark for 60 h.

Epifluorescent microscopy was used to directly measure the total number (culturable and nonculturable) of airborne microorganisms in accordance with previously described methods (25). Total numbers were used to confirm that the number of microorganisms aerosolized was constant between experiments.

**Constant Generation Test Protocol.** After cleaning the test room by supplying HEPA-filtered outside air via the ventilation system, negative pressure in the room and the ventilation rate were established. Two box fans (48-cm diameter, model 3723, Lasko Inc., West Chester, PA) were turned on to ensure room air mixing. The test room door was closed and sealed to reduce infiltration. Bioaerosol generation was started and then maintained for 90 min. During the last 30 min of generation, samples were collected in triplicate at five room locations, 1.5 m above the floor. When an experiment was completed, the test room was cleared of all bioaerosol by operating the ventilation system at its maximum of 8 ACH for at least 1 h. Experiments were first conducted with the UVGI system on and then repeated with it off. All experiments were carried out in the dark to control for photoreactivation.

UVGI effectiveness,  $E$ , is quantified by comparing the measured culturable airborne bacteria concentration with the UVGI system on,  $C_{UV\ on}$  (CFU m<sup>-3</sup>) to the airborne culturable bacteria concentration without UVGI,  $C_{UV\ off}$  (CFU m<sup>-3</sup>). Because aerosolized bacteria concentrations in the room can vary between experiments, due to differences in suspension viability, varying degrees of culturability loss, etc., the culturable airborne bacteria concentrations were normalized by the total bacteria concentration as determined

**TABLE 1. Environmental Conditions during Testing<sup>a</sup>**

ventilation configuration <sup>b</sup>	relative humidity (%)	test protocol	UVGI system fixture configuration	total lamp power (W)
<b>Relative Humidity<sup>c</sup></b>				
6 ACH	100	constant	four corner + center ceiling	216
6 ACH	100	constant	none	0
6 ACH	75	constant	four corner + center ceiling	216
6 ACH	75	constant	none	0
6 ACH	25	constant	four corner + center ceiling	216
6 ACH	25	constant	none	0
0 ACH	90	decay	four corner + center ceiling	216
0 ACH	90	decay	none	0
0 ACH	50	decay	four corner + center ceiling	216
0 ACH	50	decay	none	0
0 ACH	20	decay	four corner + center ceiling	216
0 ACH	20	decay	none	0
<b>Elevated UV Fluence Rates and Unevenly Distributed Fluence Rates</b>				
0 ACH	50	decay	2 corner + 2 wall, along west wall only	216
0 ACH	50	decay	none	0
0 ACH	50	decay	4 corner, 4wall + center ceiling	504
0 ACH	50	decay	none	0
<b>Photoreactivation and Relative Humidity</b>				
3 ACH	40	constant	none	0
3 ACH	40	constant	4 corner + center ceiling	216
3 ACH	40	constant	4 corner + center ceiling/fluorescent on	216 (UV) + 480 (visible)
3 ACH	100	constant	none	0
3 ACH	100	constant	4 corner + center ceiling	216
3 ACH	100	constant	4 corner + center ceiling/fluorescent on	216 (UV) + 480 (visible)
<b>Mixing and Ventilation<sup>d</sup></b>				
0 ACH	50	constant	4 corner + center ceiling	216
0 ACH	50	constant	none	0
6 ACH (at 34 °C)	50	constant	4 corner + center ceiling	216
6 ACH (at 34 °C)	50	constant	none	0

<sup>a</sup> Mixing fans on to ensure well-mixed conditions during all experiments, except the Mixing and Ventilation experiments. <sup>b</sup> Ventilation supply air temperature at 24 °C for all experiments, except as noted for the Mixing and Ventilation experiments. <sup>c</sup> Relative humidity experiments at 50% were conducted previously using both constant and decay test protocols (8). <sup>d</sup> During the 6 ACH experiments, ventilation air was supplied at 34 °C, resulting in a temperature stratification within the chamber of 29 and 24 °C in the upper and lower regions of the room, respectively.

by direct counting (25). The effectiveness of the UVGI system is given by

$$E = 1 - \frac{C_{UV\ on}}{C_{UV\ off}} \times \frac{D_{UV\ off}}{D_{UV\ on}} \quad (1)$$

where  $D_{UV\ off}$  and  $D_{UV\ on}$  (no. m<sup>-3</sup>) are the total airborne bacteria concentrations measured by direct counting for UVGI off and on.

Effectiveness was calculated by first averaging the culturable and total airborne bacteria concentrations measured at five locations within the room, and then applying eq 1. The standard deviation of the five room concentrations was used to estimate the error in effectiveness using error propagation.

**Decay Test Protocol.** After cleaning the test room by supplying HEPA-filtered outside air, bioaerosol was generated continuously to raise the concentration in the room to a suitable level for detection. No ventilation was provided during this period, the box fans were turned on to ensure mixing, and all lights were off. After 30 min, aerosolization was stopped, the ventilation rate and negative pressure were established, and the UVGI system was turned on. As the concentration decayed to background levels, bioaerosol was sampled in duplicate 5 times at 3–4-min intervals over 15–20 min. Samples were collected at one location, underneath the ventilation exhaust at 1.5 m above the floor. Additional experiments were conducted without the UVGI system in operation to estimate bioaerosol removal by ventilation and natural die-off. All experiments, except those isolating photoreactivation response, were carried out in the dark.

A completely mixed room model was used to evaluate the rate at which upper-room air UVGI inactivates microorganisms under decay conditions. The model is based on the assumption of perfect mixing. Model development and application to data interpretation have been comprehensively described (8, 26).

**Experimental Scenarios.** Table 1 details the environmental conditions that were varied during testing. For the relative humidity experiments using the constant generation test protocol, the test facility’s steam injection system was used for RH control. Steam was injected into the supply air and a feedback RH sensor controlled the steam injection flow rate. The RH value was very stable throughout the test, ranging ±5% of the target value for all tests. For the RH decay protocol, four portable humidifiers were operated in the chamber, two on the north side and two on the south side of the chamber (DH910, Duracraft, Southborough, MA). Using the humidifiers, the maximum humidity in the room was 90% RH without any notable condensation on room surfaces.

Two mixing and ventilation conditions were studied (Table 1): (1) mixing fans off with no ventilation (~0.3 ACH due to infiltration and negative pressure) and (2) mixing fans off with 6 ACH ventilation supplied at a temperature 10 degrees warmer than the room air (simulating wintertime heating conditions). Incomplete mixing of the room could occur during winter if the buoyancy of the warmer supply air (warmer than the room air) creates a short circuit between the supply inlet and the exhaust outlet, for ceiling supply and ceiling return systems.

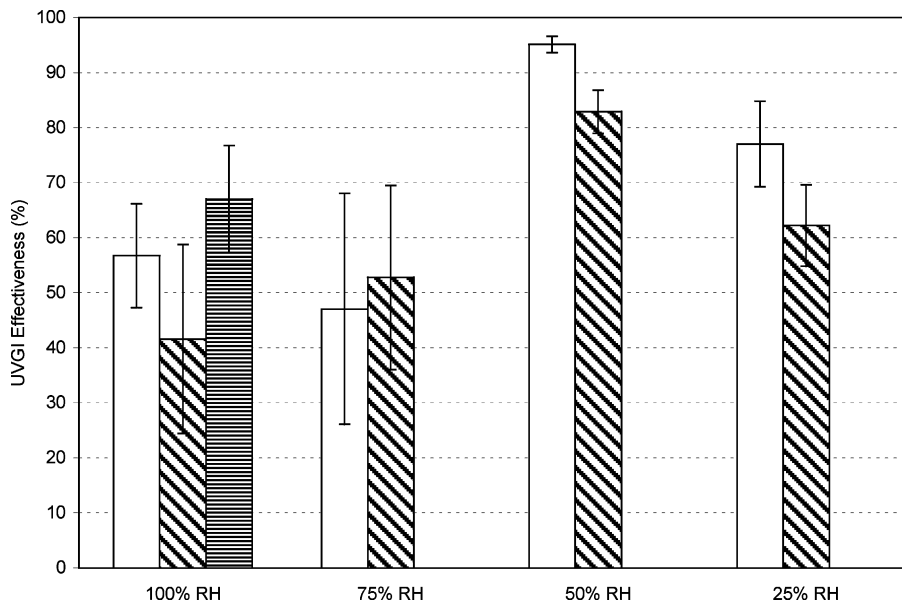

**FIGURE 2.** Effectiveness of UVGI-induced microbial inactivation for constant-generation method experiments under well-mixed conditions and varying RH at 6 air changes per hour (ACH) ventilation rate for *M. parafortuitum*. Error bars represent the standard deviation of spatial measurements. Each experiment was repeated twice, except for the 100% RH condition, which was repeated 3 times. The effectiveness is based on the average of concentrations measured within the room at five different locations (Figure 1); the standard deviation of these five concentrations is propagated and shown in the error bars.

**TABLE 2.** Average UV Fluence Rate Measured in the Upper Zone of the Room by Actinometry for Different Lamp Configurations

UV fluence rate ( $\mu\text{W cm}^{-2}$ )	UVGI system fixture configuration	lamp power (W)
12	3 corner with 1 lamp operating in each	54
20	4 corner with 1 lamp operating in each, center ceiling with 2 lamps operating	108
33	3 corner with 2 lamps operating in each, 1 corner with 1 lamp operating, center ceiling with 2 lamps operating	162
42 <sup>a</sup>	4 corner, center ceiling <sup>b</sup>	216
44	2 corner and 2 wall, along west wall only <sup>b</sup>	216
87	4 corner, 4 wall, center ceiling <sup>b</sup>	504

<sup>a</sup> Ref 8. <sup>b</sup> All lamps in fixtures operating.

## Results

**UV Fluence Rates.** Average UV fluence rates for differing lamp configurations and power as determined by spherical actinometry are presented in Table 2. Actinometer measurements for the four corner fixtures and center ceiling fixture (216 W total lamp power) have been reported elsewhere, although the average fluence rate is reproduced in Table 2 for completeness (8). In general, the measured fluence rate varied widely across the room, from close to zero farther away from the lamps to very high nearest the lamps. For example, the UV fluence rate when UV fixtures along the west side of the room were operated (216 W) was 140–160  $\mu\text{W cm}^{-2}$  nearest to the lighted side of the room, while on the other side the fluence rate was 2–10  $\mu\text{W cm}^{-2}$ . The average of this skewed configuration agrees with the more uniform configuration of four corner plus center fixtures in which the fluence rate ranged from 25 to 81  $\mu\text{W cm}^{-2}$  (8).

**Effectiveness of UVGI for Various RH Conditions.** Figure 2 summarizes the effectiveness, as determined by constant generation experiments, of the UVGI system (corner plus center fixtures operating, 216 W) for different relative humidity levels under well-mixed conditions with 6 ACH

ventilation. The effectiveness is based on the average of concentrations measured within the room at five different locations (Figure 1); the standard deviation of these five concentrations is propagated and shown in the error bars. The average effectiveness based on three experiments (and propagated standard deviation) at 100% RH was 55% (7.3%). At 75% and 25% RH, the average effectiveness based on two experiments was 50% (13%) and 70% (5.4%), respectively. The effectiveness at 50% RH was determined previously to be 89% (8).

Independent, unequal variance *t*-tests (one tail,  $\alpha = 0.05$ ) were conducted on the average effectiveness derived from repeat experiments. The tests showed the effectiveness of UVGI was significantly decreased for RH at 75% or above.

**UVGI Inactivation Rate for Various RH Conditions.** Decay experiment data used to determine inactivation rates induced by UVGI for various RH conditions are presented in Figure 3. The least-squares method was used to estimate inactivation rates, which were calculated by subtracting rates observed without UV from those with UVGI. Standard errors of each regression are reported and propagation of errors applied. Error bars in the figure show the standard deviation of triplicate samples.

The inactivation rate ( $\pm$  propagated standard deviation) of the UVGI system (4 corner and center ceiling fixtures operating, 216 W) under well-mixed conditions was  $8.8 \pm 1.5 \text{ h}^{-1}$  for 90% RH,  $18 \pm 2.0 \text{ h}^{-1}$  for 50% RH, and  $21 \pm 1.8 \text{ h}^{-1}$  for 20% RH. Increasing RH from 50 to 90% decreased the inactivation rate by half. Increasing the RH from 20 to 50% did not have as dramatic an effect: the equivalent air-exchange rate decreased by 15%. The equivalent air-exchange rate derived in these experiments for 50% RH agrees with the rate previously derived:  $16 \pm 1.8 \text{ h}^{-1}$  (8).

**UVGI Inactivation Rate for Unevenly Distributed UV Radiation.** Figure 4 shows the data for the decay experiments used to determine inactivation rates induced by UVGI for unevenly distributed UV radiation within the upper portion of the room. For the three experiments conducted, the UVGI inactivation rates (2 corner fixtures and 2 wall fixtures along west wall operating, 216 W) under well-mixed conditions were  $10 \pm 0.9$ ,  $11 \pm 1.3$ , and  $14 \pm 1.7 \text{ h}^{-1}$ . The average inactivation rate for unevenly distributed UVGI was  $12 \pm 1.3$

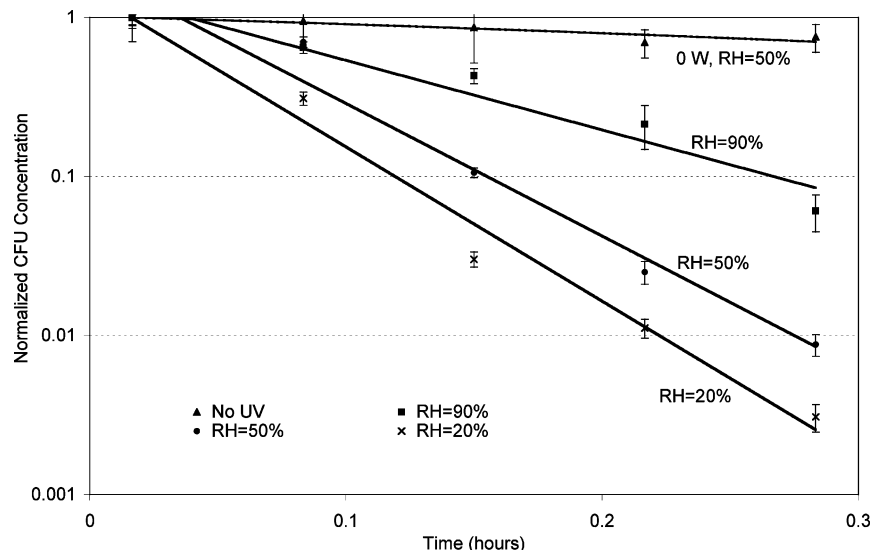

FIGURE 3. Data from decay method experiments used to determine inactivation rates at 20, 50, and 90% relative humidity for *M. parafortuitum* under well-mixed conditions with 0 ACH ventilation and UVGI (4 corner and center ceiling fixtures) at 216 W. UVGI inactivation rates are the difference between the slopes of the lines with UVGI on and off. Error bars indicate the standard deviation of triplicate samples.

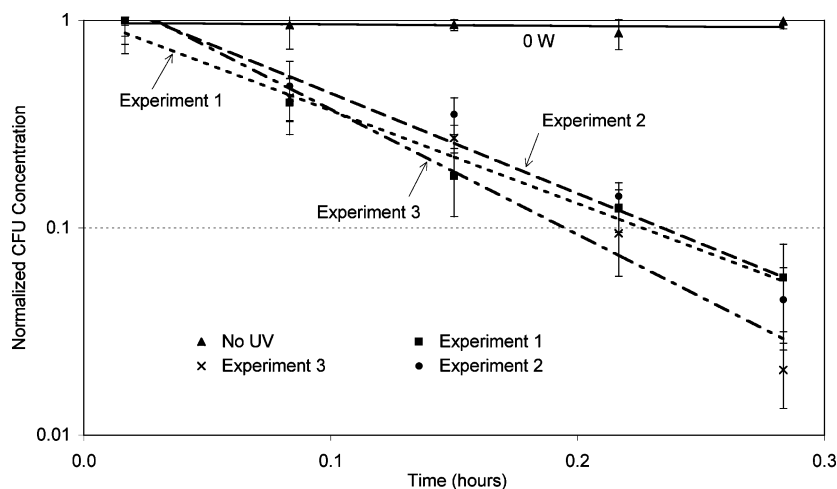

FIGURE 4. Data from decay method experiments used to determine inactivation rates induced by UVGI for unevenly distributed UV radiation (all luminaries along west wall, 216 W) for *M. parafortuitum* under well-mixed conditions with 0 ACH ventilation. Data are shown for three repeat experiments. UVGI inactivation rates are the difference between the slopes of the lines with UVGI on and off. Error bars indicate the standard deviation of triplicate samples.

$\text{h}^{-1}$ . Compared with the average rate ( $16 \pm 1.2 \text{ h}^{-1}$ ) previously derived under the more uniform radiation distribution achieved by 4 corner fixtures and one center fixture (216 W), the inactivation rate decreased by 25% (8).

**UVGI Inactivation Rate for Elevated Levels of UV Radiation.** Decay experiments were used to determine inactivation rates induced by UVGI for elevated levels of UV radiation. For these experiments 9 fixtures were operated (four corner, four wall, and one center fixture, 504 W). UVGI inactivation rates were  $19 \pm 2.9$  and  $19 \pm 2.4 \text{ h}^{-1}$  for the two tests, respectively, and the average was  $19 \pm 1.9 \text{ h}^{-1}$  (data not shown). Compared to the inactivation rate ( $16 \pm 1.2 \text{ h}^{-1}$ ) from previous experiments under 216 W total lamp power, the inactivation rate increased by 19%.

**Effectiveness of UVGI under Photoreactivation Conditions.** Photoreactivation was isolated as a process variable by comparing effectiveness for UV on/fluorescent off conditions to UV on/fluorescent on conditions (Table 3). Statistically significant photoreactivation responses could not be isolated under any of the conditions tested.

**Effectiveness of UVGI for Incomplete Mixing Conditions.** The effectiveness of the UVGI system (corner plus center

fixtures operating, 216 W) under incomplete mixing and varying ventilation conditions is shown in Figure 5. For comparison purposes, previously published data are also presented (8). The effectiveness is based on the average of concentrations measured within the room at five different locations (Figure 1); the standard deviation of these five concentrations is propagated and shown in the error bars. UVGI performance was unaffected by the operation of mixing fans when the test room was not ventilated (0 ACH; independent *t*-test,  $\alpha = 0.05$ ). At 6 ACH and wintertime ventilation conditions (ventilation supply air elevated at 34 °C compared to room temperature at 24 °C), however, the UVGI effectiveness decreased significantly from an average of 89% to 12% when the mixing fans were turned off (independent *t*-test,  $\alpha = 0.05$ ). The large error bars shown in the figure indicate that the room concentrations were highly variable compared to the conditions in which mixing fans were deployed or in which there was no temperature stratification. Vertical stratification in concentrations was observed during one of the wintertime condition experiments in which additional air samples were collected at the ceiling and floor. The breathing zone concentration ( $3.96 \times 10^3 \text{ CFU}$

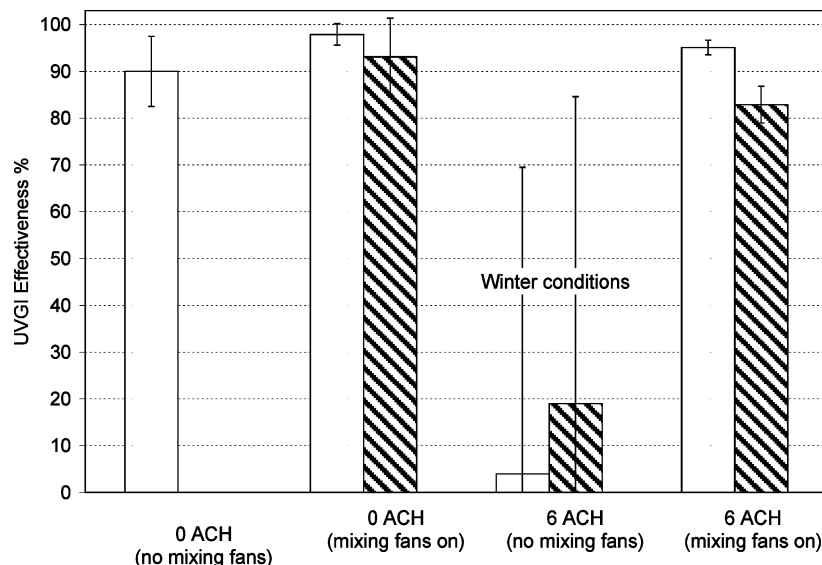

**FIGURE 5. Effectiveness of UVGI-induced microbial inactivation for constant generation method experiments under different room air mixing conditions for 50% RH with 0 or 6 air changes per hour (ACH) ventilation rate for *M. parafortuitum*. Each experiment was repeated twice, except for the 0 ACH experiment. The effectiveness is based on the average of concentrations measured within the room at five different locations (Figure 1); the standard deviation of these five concentrations is propagated and shown in the error bars.**

**TABLE 3. Results for Photoreactivating Conditions at 40% and 100% Relative Humidity<sup>a</sup>**

exp. no.	fixture configuration	effectiveness <i>E</i> (%)
<b>40% RH</b>		
1	UV on/fluorescent off	85 ± 5.9
	UV on/fluorescent on	83 ± 11
2	UV on/fluorescent off	85 ± 5.5
	UV on/fluorescent on	81 ± 11
<b>100% RH</b>		
1	UV on/fluorescent off	42 ± 7.4
	UV on/fluorescent on	40 ± 8.0
2	UV on/fluorescent off	60 ± 12
	UV on/fluorescent on	43 ± 6.5

<sup>a</sup> Average ± standard deviation was calculated using measurements from 5 breathing zone locations within the room.

$m^{-3}$ ) was significantly higher than both the ceiling ( $2.50 \times 10^3$  CFU  $m^{-3}$ ) and the floor ( $3.13 \times 10^3$  CFU  $m^{-3}$ ) concentrations (independent *t*-test,  $\alpha = 0.05$ ).

**Relationship between UVGI Inactivation Rate and Effective Fluence Rate.** Effective fluence rate is defined here as the fluence rate measured in the upper-room zone only normalized to the fraction of room volume irradiated by UV ( $10.4 m^3/87 m^3 = 12\%$ ). To investigate the association between inactivation rate and effective fluence rate through a broad range of conditions, we observed inactivation responses at 504 W total power applied, which was more than double the power applied in previous studies under otherwise identical conditions (8). Results are summarized in Figure 6, which shows a linear relationship between inactivation rate and effective fluence rate from 2 to  $5 \mu W cm^{-2}$ , reproduced from Xu et al. (8). However, increasing the effective fluence rate above  $10 \mu W cm^{-2}$  did not yield a proportional increase in inactivation rate.

## Discussion

High relative humidity has been shown to significantly impact the effects of UVGI. Our results showed that for *M. parafortuitum*, the effectiveness decreased by 40% when the RH was increased above 75% and the equivalent air-exchange rate decreased by half when the RH was increased from 50

to 90%. Our results did not provide conclusive evidence that effectiveness decreased below 25% RH. This trend, however, of maximum UV decay rate near 50% and decreasing with higher and lower relative humidity has been previously observed in lab-scale studies that isolated intrinsic UV inactivation response of airborne *M. parafortuitum* and *Serratia marcescens* (11, 12).

The number of UVGI fixtures appropriate for effective airborne bacteria inactivation depends on a number of factors, with the most important being the room volume and the design UV dose. A general rule has been previously suggested: one 30-W fixture for every  $18 m^2$  ( $200 ft^2$ ) of floor area, or for every seven people in a room, whichever is greater (27, 28). The total wattage area power distribution for our room, for the corner plus ceiling fixtures operating, was almost four times higher than the recommendation cited above:  $216 W/35 m^2 = 6.2 W m^{-2}$  compared to  $30 W/18 m^2 = 1.7 W m^{-2}$ . Given that ceiling heights and UV output from fixtures vary, an alternative guideline is to design UV installations based on the volume of the room that is irradiated and the total UV-C wattage applied. For our test room, the UV-C wattage volume power distribution was  $5.5 W \times 12 lamps/10.4 m^3 = 6.3 W m^{-3}$ .

We found that the distribution of UV radiation within a room can have significant impact on the UVGI inactivation rate. Even with completely mixed room air, operating lamps on only one side of the room adversely affected the UVGI inactivation rate by as much as 30% compared to operating lamps uniformly throughout the room with the same total lamp power.

At the highest effective fluence rate that we studied, the relationship between inactivation rate and fluence rate is no longer linear. This finding implies that a higher fluence rate from a UVGI system provides better inactivation of airborne bacteria up to a threshold, beyond which adding more UVGI will not substantially increase the rate of inactivation.

Our studies reported here are the first to investigate photoreactivation for bacterial aerosols under full-scale environmental conditions. We found that no photoreactivation effects could be isolated. A previous study in a small lab-scale aerosol reactor found evidence of photoreactivation in *Mycobacterium parafortuitum* when the RH level was above 65% (17). Additionally, several differences in full-scale and lab-scale studies may have contributed to these obser-

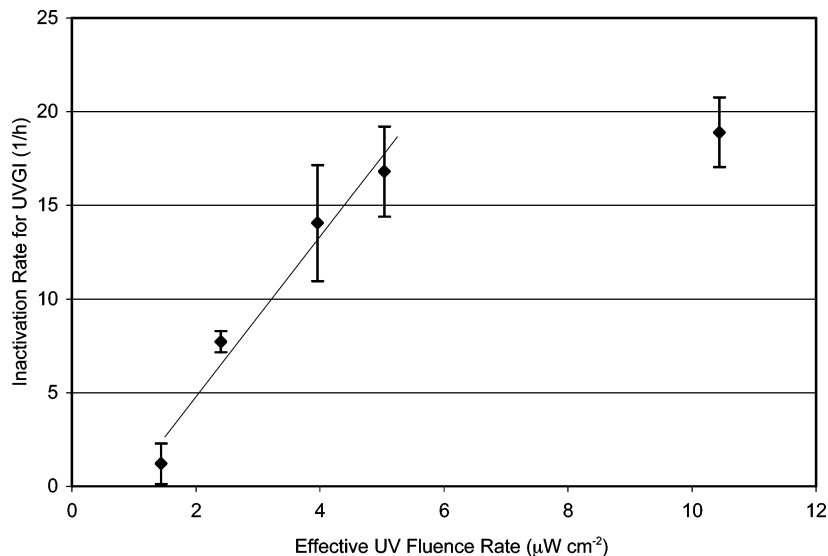

**FIGURE 6. UVGI-induced inactivation rate as a function of effective UV fluence rate for *M. parafortuitum* under well-mixed conditions for 54 W to 504 W lamp power. Effective UV fluence rate is the fluence rate measured in the upper-room zone only normalized to the fraction of room volume irradiated by UV (0.3 m<sup>2</sup>/2.5 m). Tests conducted at 50% RH. Some of the data have been reproduced from ref 8.**

variations. One important difference is the lower exposure to photoreactivating light at full-scale conditions. Previous lab-scale reactor experiments used one 40-W lamp in 0.8 m<sup>3</sup> volume for a total wattage volume power distribution of 50 W m<sup>-3</sup>. The full-scale experiments used 12 40-W lamps in 87 m<sup>3</sup> for a total wattage volume power distribution of 5.5 W m<sup>-3</sup>. Another difference was the test protocol. The lab-scale study used the decay test protocol. In the full-scale experiment described here, a constant generation method was used in which new cells were constantly being added to the room. For experiments that last the same duration and have the same residence times, the average amount of bioaerosol exposure to both UV and photoreactivating light is less under the constant generation test protocol. Further, photoreactivation likely depends on the volume of air that is irradiated with UV. In our studies, only the upper-room volume was irradiated as compared to lab-scale studies in which the entire volume of the lab-scale reactor was irradiated (17). While the lab-scale studies confirm that photoreactivation is possible in model bacterial aerosols, the data presented here suggest that under common room lighting conditions, photoreactivation may not have substantial effects at full-scale operation.

An important factor affecting upper-room UVGI systems is the room airflow pattern. Our experiments indicate that poor air mixing can decrease UVGI effectiveness by almost 80% under wintertime ventilation conditions (34 °C supply air temperature and 24 °C room air temperature). Riley et al. found similarly that hot supply air without a mixing fan decreased the UVGI-induced inactivation rate by 60% compared to conditions of hot supply air with a mixing fan (31).

This study evaluated the following factors influencing the performance of upper-room air UVGI: room ventilation rates, UV fluence rates and distribution, airflow patterns, relative humidity, and photoreactivation. The results of this study suggest that to obtain maximum benefit from an upper-room air UVGI system inactivating airborne *Mycobacteria*, an adequate level of UV radiation should be provided within a symmetric volume (at least 6 W of UV-C per m<sup>3</sup> in the upper zone); the UV radiation should be evenly distributed; room air mixing should be ensured; operational room relative humidity should be kept around 50%; and photoreactivation is likely not an issue at full-scale operation.

As is true for many engineering control technologies, UVGI systems will be successfully applied in environments that have a steady supply of power to illuminate the lights. The recommendation from this study—for considerably higher UVGI fluence rates (in the upper zone) than previously suggested in the literature—means that routine monitoring of fluence rates to ensure exposure limits are met must take place in the occupied zones (32). Designs at these fluence rates are feasible and would result in limited additional electricity costs, since the lamps are low wattage, although the cost of additional fixtures could be substantial.

### Acknowledgments

This research was supported by funds provided by the Centers for Disease Control and Prevention, National Institute of Occupational Safety and Health, contract 200-97-2602, and the National Science Foundation, Grant BES 00-734-1505. Dr. Ronald Rahn was instrumental in the characterization of UV fluence rates in our test room. We appreciate Charlie Dunn for assistance with the lamp installation and for his expertise in UVGI system design and manufacturing. The Joint Center for Energy Management provided essential equipment and operated the test facility.

### Literature Cited

- (1) Centers for Disease Control and Prevention. Guidelines for preventing the transmission of *Mycobacterium tuberculosis* in health-care facilities. *MMWR* **1994**, *43* (RR-13), 1–132.
- (2) Nagin, D.; Pavelchak, N.; London, M.; DePersis, R. P.; Melius, J. Control of tuberculosis in the workplace – engineering controls. *Occup. Med.* **1994**, *9*, 609–630.
- (3) Ko, G.; First, M. W.; Burge, H. A. The characterization of upper-room ultraviolet germicidal irradiation in inactivating airborne microorganisms. *Environ. Health Persp.* **2002**, *110*, 95–101.
- (4) Macher, J. M.; Alevantis, L. E.; Chang, Y.-L.; Liu, K.-S. Effect of ultraviolet germicidal lamps on airborne microorganisms in an outpatient waiting room. *Appl. Occup. Environ. Hyg.* **1992**, *7*, 505–513.
- (5) Macher, J. M.; Alevantis, L. E.; Chang, Y.-L.; Liu, K.-S. *Appl. Occup. Environ. Hyg.* **1994**, *9*, 462 (letter).
- (6) Miller, S. L.; Macher, J. M. Evaluation of a methodology for quantifying the effect of room air ultraviolet germicidal irradiation on airborne bacteria. *Aerosol Sci. Technol.* **2000**, *33*, 274–295.
- (7) Riley, R. L.; Knight, M.; Middlebrook, G. Ultraviolet susceptibility of BCG and virulent tubercle bacilli. *Am. Rev. Respir. Dis.* **1976**, *113*, 413–418.

- (8) Xu, P.; Peccia, J.; Fabian, P.; Martyny, J. W.; Fennelly, K.; Hernandez, M.; Miller, S. L. Efficacy of ultraviolet germicidal irradiation of upper-room air in inactivating bacterial spores and Mycobacteria in full-scale studies. *Atmos. Environ.* **2003**, *37*, 405–419.
- (9) Wells, W. F.; Wells, M. W. Air-borne infection sanitary control. *JAMA, J. Am. Med. Assoc.* **1936**, *107*, 1805–1809.
- (10) Whisler, B. A. The efficacy of ultra-violet light sources in killing bacteria suspended in air. *J. Sci., Iowa State College* **1940**, *14*, 215.
- (11) Riley, R. L.; Kaufman, J. E. Effect of relative humidity on the inactivation of airborne *Serratia marcescens* by ultraviolet radiation. *Appl. Microbiol.* **1972**, *23*, 1113–1120.
- (12) Peccia, J.; Werth, H.; Miller, S. L.; Hernandez, M. The effects of relative humidity on the ultraviolet induced inactivation of airborne bacteria. *Aerosol Sci. Technol.* **2001**, *35*, 728–740.
- (13) Nicholson, W. Photoreactivation in the genus *Bacillus*. *Curr. Microbiol.* **1995**, *31*, 361–364.
- (14) David, H. L.; Jones, W. D.; Newman, C. M. Ultraviolet light inactivation and photoreactivation in the mycobacteria. *Infect. Immun.* **1971**, *4*, 318–319.
- (15) Liltved, H.; Landfald, B. Influence of liquid holding recover and photoreactivation on survival of ultraviolet-irradiated fish pathogenic bacteria. *Water Res.* **1996**, *30*, 1109–1114.
- (16) Oguma, K.; Katayama, H.; Ohgaki, S. Photoreactivation of *Escherichia coli* after Low- or Medium-Pressure UV Disinfection Determined by an Endonuclease Sensitive Site Assay. *Appl. Environ. Microbiol.* **2002**, *68*, 6029–6035.
- (17) Peccia, J.; Hernandez, M. Photoreactivation in Airborne *Mycobacterium parafortuitum*. *Appl. Environ. Microbiol.* **2001**, *67*, 4225–4232.
- (18) Peccia, J.; Hernandez, M. Rapid immunoassays for detection of UV-induced cyclobutane pyrimidine dimers in whole bacterial cells. *Appl. Environ. Microbiol.* **2002**, *68*, 2542–2549.
- (19) Black, D. R.; Harley, R. A.; Hering, S. V.; Stolzenburg, M. R. A new, portable, real-time ozone monitor. *Environ. Sci. Technol.* **2000**, *34*, 3031–3040.
- (20) Rahn, R. O.; Xu, P.; Miller, S. L. Dosimetry of room-air germicidal irradiation using spherical actinometry. *Photochem. Photobiol.* **1999**, *70*, 314–318.
- (21) Foarde, K.; Myers, E.; Hanley, J.; Ensor, D.; Roessler, P. Methodology to Perform Clean Air Delivery Rate Type Determinations with Microbiological Aerosols. *Aerosol Sci. Technol.* **1999**, *30*, 235–245.
- (22) McCullough, N. V.; Brosseau, L. M.; Vesley, D.; Vincent, J. H. Improved methods for generation, sampling, and recovery of biological aerosols in filter challenge tests. *Am. Ind. Hyg. Assoc. J.* **1998**, *59*, 234–241.
- (23) Reponen, T. A.; Wang, Z.; Willeke, K.; Grinshpun, S. A. Survival of mycobacteria on N95 personal respirators. *Infect. Cont. Hosp. Ep.* **1999**, *20*, 237–241.
- (24) Lin, X.; Reponen, T. A.; Willeke, K.; Grinshpun, S. A.; Foarde, K. K.; Ensor, D. S. Long-term sampling of airborne bacteria and fungi into a non-evaporating liquid. *Atmos. Environ.* **1999**, *33*, 4291–4298.
- (25) Hernandez, M.; Miller, S. L.; Landfear, D. W.; Macher, J. M. A combined fluorochrome method for quantification of metabolically active and inactive airborne bacteria. *Aerosol Sci. Technol.* **1999**, *30*, 145–160.
- (26) Offermann, F. J.; Sextro, R. G.; Fisk, W. J.; Grimsrud, D. T.; Nazaroff, W. W.; Nero, A. V.; Revzan, K. L.; Yater, J. Control of respirable particles in indoor air with portable air cleaners. *Atmos. Environ.* **1985**, *19*, 1761–1771.
- (27) Macher, J. M. The use of germicidal lamps to control tuberculosis in healthcare facilities. *Infect. Control Hosp. Ep.* **1993**, *14*, 723–729.
- (28) Riley, R. L. Ultraviolet air disinfection for control of respiratory contagion. In *Architectural Design and Indoor Microbial Pollution*; Kundsir, R.; Ed.; Oxford University Press: New York, 1988; pp 172–197.
- (29) Peccia, J. *The Response of Airborne Bacteria to Ultraviolet Germicidal Irradiation*. Ph.D. Dissertation, The University of Colorado, Boulder, CO, 2000.
- (30) Rahn, R. O.; Hosszu, J. L. Influence of relative humidity on the photochemistry of DNA films. *Biochim. Biophys. Acta* **1969**, *190*, 126–131.
- (31) Riley, R. L.; Permutt, S.; Kaufman, J. E. Convection, air mixing, and ultraviolet air disinfection in rooms. *Arch. Environ. Health* **1971**, *22*, 200–207.
- (32) ACGIH. Ultraviolet Radiation. In *Threshold Limit Values (TLVs) for Chemical Substances and Physical Agents and Biological Exposure Indices (BEIs)*; American Conference of Government Industrial Hygienists: Cincinnati, OH, 2005; pp 155–158.

Received for review March 12, 2005. Revised manuscript received September 23, 2005. Accepted October 20, 2005.

ES0504892