

MIFACE INVESTIGATION REPORT: #10MI013

Subject: Tub Refinisher Died Due to Methylene Chloride Overexposure While Stripping a Bathtub

Summary

In the winter of 2010, a 52-year-old male tub re-glazer died due to overexposure to methylene chloride (MC) vapor while stripping a bathtub in an apartment bathroom using Tal-Strip® II Aircraft Coating Remover (Tal-Strip® II). Methylene chloride was the primary ingredient of the aircraft-grade Tal-Strip® II (60%-100%). The work process involved pouring Tal-Strip® II directly from the container onto the tub surface and using a 4-inch paintbrush to spread the product. At approximately 9:30 a.m., the decedent arrived at the apartment complex. At approximately 11:10 a.m., one of the apartment maintenance personnel attempted to contact the



Figure 1. Incident bathtub, brush used to spread product and location and swing of bathroom door

decedent via cell phone. The decedent did not answer his phone, so the maintenance person went to the apartment to talk with him. The maintenance person found the decedent slumped over the tub on his knees with his face in the tub (Figure 1). The maintenance person called 911 and then called another maintenance person and instructed him to tell the property manager about the decedent's situation. After speaking with the property manager, the second maintenance person went to the apartment. When he arrived, he checked the decedent's pulse. Finding no pulse, the apartment employees pulled the decedent out of the tub and laid him on the bathroom floor. The second maintenance person checked the decedent's pulse again and also checked his airway for any blockage; he found no pulse or blockage. The second individual, a certified EMT, started CPR which lasted approximately two minutes. Emergency response arrived and transported the decedent to a nearby hospital where he was declared dead. The high concentration of MC in the product, the room configuration, the nature of the work, the lack of ventilation, and lack of proper respiratory protection contributed to his excessive exposure and subsequent death.

RECOMMENDATIONS

Bathtub/tile refinishers should:

- Use alternative stripping methods, such as sanding or strippers that do not contain methylene chloride or acids. Read and follow all label and Material Safety Data Sheet (MSDS) instructions for use.

- Implement a push-pull (fresh air and local exhaust) ventilation system if using MC-based strippers to reduce the airborne concentration of MC.
- Always use a NIOSH-approved pressure demand, full-facepiece supplied air respirator (fresh air system) when using MC-based products due to MC's classification as a carcinogen and the individual's exposure to potential life threatening levels above the Permissible Exposure Limit (PEL) and Short Term Exposure Limit (STEL). A written respiratory protection program should be developed and implemented.
- Develop and implement a Methylene Chloride exposure management plan that addresses the requirements of MIOSHA's Methylene Chloride Occupational Health Standard Part 313 if using a MC-based stripping agent.
- Conduct employee time weighted average (TWA) exposure monitoring as part of the Methylene Chloride Exposure Plan and in compliance with MIOSHA's Methylene Chloride Occupational Health Standard, Part 313 and institute appropriate engineering, administrative and personal protective equipment control measures based on the monitoring results.
- Perform on-the-spot air monitoring to provide immediate feedback to determine the effectiveness of implemented ventilation.
- Select and wear appropriate personal protective equipment, including face protection and gloves based upon the work operations to be performed and the product's Material Safety Data Sheet (MSDS).
- Determine and implement safe work practices to reduce exposure.

Manufacturers/distributors of aircraft-grade MC-based stripping products whose product is intended for the aircraft and/or other industries but are being used in bathroom/kitchen tub, sink, and tile refinishing industry should:

- Provide additional labeling and educational outreach regarding safe use of their products and consider ways to restrict their use so that it cannot be used in the bathtub refinishing industry.

INTRODUCTION

MIFACE investigators were informed of this work-related fatality by the Michigan Occupational Safety and Health Administration (MIOSHA) personnel, who had received a report on their 24-hour-a-day hotline. In May 2010, the MIFACE investigator spoke with one of the company owners at his home about the fatality. During the writing of this report, the police and medical examiner reports, the death certificate and the MIOSHA investigation file were reviewed. Pictures used in Figures 1, 7 and 8 were taken by the responding police department. MIOSHA was escorted to a similar apartment layout for bathroom measurements and pictures; pictures used in Figures 2, 3, 4 and 5 were taken by the MIOSHA compliance officer at the time of the MIOSHA investigation.

The firm had been in business for 14 years. The firm had three owners; the deceased was one of the owners and had been one of the owners for the past five years. The firm primarily repaired and resurfaced counter tops, tubs and sinks in apartment buildings, but occasionally performed similar work in private homes. The company owners worked both independently on projects (and

received the total pay for the project) as well as together on projects, when pay was shared equally among the owners working on the project. Owners had their own clients that they billed to the name of the firm. The owner of the apartment complex where the deceased was working was his client, and the client had contacted him to perform repair and re-glazing on several tub units.

The owner MIFACE spoke with provided on-the-job training to the decedent. The decedent worked with him for approximately one month before he began to perform jobs on his own. The training did not consist of any training for respiratory protection. The training consisted of: 1) the work process, 2) to not turn on the bathroom ceiling fan, 3) to leave the bathroom door open, and 4) to leave the bathroom and let the product set up and work, 5) to return after 20-30 minutes and scrape the product from the tub. The owner indicated that latex or nitrile gloves were worn during application/removal of the Tal-Strip® II.

The owner stated that the fan was not routinely turned on because it would draw the MC vapor up past someone's face. The owner also noted that the decedent routinely did not leave the work area after applying the product and that he would begin to scrape the product sooner than the set time of 20-30 minutes. The owner indicated that decedent was "pretty conservative"

with the product and that one (128 oz) container would last about 10 multi-strips (tubs that require more than one coat of product) or 20 single strips (one coat of product).

All of the company owners were responsible for purchasing and maintaining their own work tools and safety equipment. The firm did not have a written safety program or written safety rules or procedures for using the Tal-Strip® II. The owner stated that, at the time of the fatality, the firm did not have a Tal-Strip® II material safety data sheet (MSDS) nor maintenance records for the respiratory protection equipment. The owner MIFACE spoke with was unfamiliar with the requirements of the MIOSHA Occupational Health Standard, Part 313, Methylene Chloride.

Figures 2-4 show the respirators and associated equipment owned by the owner MIFACE spoke with during the on-site interview. Both full-face, supplied air respirators (SARs) and half-mask respirators equipped with organic vapor cartridges were purchased and, the owner noted, should have been available for use depending upon the job parameters.



Figure 2. Air purifying, half-face piece respirator with cartridges



Figure 3. Full-face air supplied respirator



Figure 4. Air pump that supplied breathing air to the supplied air respirator system

The owner MIFACE spoke with had the sales literature for his continuous-flow supplied air respirator (SAR). The owner referred to the SAR system as a “fresh air breathing system”. This respirator system included a 20-foot, 1-inch diameter inlet extension hose to bring in air from another location, a GAST pump, a 20- to 25-foot air supply hose, and a full-face, tight-fitting respirator. The owner indicated that when he used the respirator, he placed the inlet extension hose out a window after ensuring that the fresh air supply was not contaminated with other contaminants, such as diesel fumes, cigarette smoke, etc.

The owner MIFACE spoke with had not received medical clearance nor fit testing to wear a respirator. Prior to the incident, the owner indicated that he only used his “fresh air breathing apparatus” 4-5 times. He identified it took too long to set up and use the SAR system (i.e., approximately 45 minutes to carry the respirator system to the worksite, set it up, and dismantle it) especially for short-duration jobs. The owner MIFACE spoke with stated that he had been light-headed in the past and continued to work or would leave the work area, let his head “clear”, and then return to the job. Since the fatal incident, the owner routinely uses his SAR system, and he uses odor as a warning sign to determine if the respirator is leaking. If he smells the product, then he readjusts his respirator.

To the owner’s knowledge, the decedent did not have a medical evaluation nor fit testing to determine if he was medically fit to wear a respirator. He stated that the decedent, when he got light-headed, would routinely leave the work area and go to fresh air. On occasion, the decedent would call a family member to bring him his “breathing apparatus”.

The MIOSHA Construction Safety and Health Division issued the following Serious citations at the conclusion of its investigation:

SERIOUS: MC, PART 313

- 1910.1052(d)(2): The employer did not perform initial exposure monitoring to determine each affected employee’s exposure to MC.
- 1910.1052(c)(1): The employer allowed an employee performing tub-stripping operations to be exposed to a calculated 8-hour time weighted average (TWA) concentration of MC in excess of the permissible exposure limit of 25 ppm established by this standard.

A reasonable combination of engineering controls, work practices, and personal protective equipment must be utilized to achieve compliance with the TWA.

- 1910.1052(f)(1): The employer did not implement feasible engineering (e.g. ventilation or substitution to a less hazardous stripping agent) and work practice controls at the Apartment Complex to reduce employee exposures to MC within the permissible exposure limits (PELs). Specifically, the employer allowed an employee performing tub-stripping operations to be exposed to MC in excess of the permissible exposure limits established by this standard.

Feasible engineering controls and work practices must be implemented to reduce employee exposures to MC below the PELs. If these controls are not sufficient to

reduce employees exposures below the PELs, then the employer must supplement paragraph(g) of this section.

- 1910.1052(e)(3): The employer did not require the use of proper respiratory protection by employees whenever the MC exposures in their work area were likely to exceed the 8-hour TWA, PEL, or STEL.

Establish policies and procedures for determining proper respirator selection and use by employees whenever their work practices will result in exposures in excess of the 8-hour TWA, PEL, or STEL.

- 1910.1052(g)(2)(i): The employer did not develop and implement a written respiratory protection program in accordance with 29 CFR 1910.134(b)-(m) [except (d)(1)(iii)] as required by this standard.

Develop and implement a written respiratory protection program with worksite specific procedures for MC exposure that includes the requirements outlined in 1910.134(c)(1) of the Respiratory Protection Standard.

- 1910.1052(1)(1): The employer did not provide information and training on MC as specified in 1910.1052(1).

SERIOUS: HAZARD COMMUNICATION, PART 430, 1910.1200(E)(1):

The employer did not develop, implement, and maintain a written hazard communication program which describes how the criteria in 29 CFR 1910.1200 (e), (f), (g), and (h) will be met.

SERIOUS: GENERAL RULES, PART 1, Rule 114(1):

An accident prevention program was not developed, maintained, and coordinated with employees.

BACKGROUND

Methylene Chloride

Methylene chloride (also known as dichloromethane) is a volatile, colorless liquid with a sweet, chloroform-like odor. It is a solvent and is used many applications including paint removers. Figure 5 shows a picture of the container from which Tal-Strip® II was poured in this incident.

Mar-Hyde® Tal-Strip® II Aircraft Coating Remover is a mixture of ingredients; the primary ingredient is MC. Relevant physical characteristics for MC that were factors in this fatality incident include:

- MC vapor is heavier than air (MC vapor density=2.9 compared to Air=1). MC vapors will tend to stay at ground level rather than evenly distribute in the room air.



Figure 5. Container of Tal-Strip® II used by decedent

- MC Volatility – Qualitative measures of volatility are Vapor Pressure and Boiling Point.
 - Vapor Pressure: The measure of the tendency of a chemical to want to spontaneously leave the bulk liquid/solid state and enter the vapor state. Substances with high vapor pressures are highly volatile. The vapor pressure of MC is 350 mm Hg at 68⁰F.
 - Boiling Point: Temperature at which its vapor pressure is equal to the atmospheric pressure. The lower the boiling point, the more volatile the substance. The boiling point of MC at 760 mm Hg is 104⁰F. (As a comparison, water boils at 212⁰F)

The MSDS for Tal-Strip® II Aircraft Coating Remover, 3713 listed the following ingredients:

Ingredient	% by Weight
MC	60-100
Ethyl Alcohol	3-7
Stoddard Solvent	1-5
Clay-Treated Paraffin Waxes	1-5
Water	1-5
Methyl Alcohol	1-5
Acetic Acid	1-5
Sodium Dodecylbenzenesulfonate	0.5-1.5
Hydroxypropyl Methyl Cellulose	0.5-1.5
Propylene Oxide	<0.1

Health Effects

Inhaled MC is readily absorbed into the body through the lungs and also can be absorbed through skin. MIOSHA, federal OSHA, and the National Toxicity Program (NTP) consider MC to be a **carcinogen**. The International Agency for Research on Cancer (IARC) has classified MC as possibly carcinogenic to humans (Group 2B). Human studies have shown excesses of cancer at specific tissue sites, including the pancreas, brain and central nervous system, breast and lymphohematopoietic system (the system that is involved in the production of lymphocytes and cells of the blood, bone marrow, spleen, lymph nodes and thymus). MIOSHA Occupational Health Standard, Methylene Chloride Part 313 states that “Employees exposed to MC are at increased risk of developing cancer, adverse effects on the heart, central nervous system and liver, and skin or eye irritation.”

Short-term exposures to high levels of MC can cause workers to feel tired, dizzy, have headaches and lack coordination. The liver metabolizes MC to carbon monoxide and this carbon monoxide binds with hemoglobin in red blood cells to form carboxyhemoglobin. Because hemoglobin binds to carbon monoxide preferentially compared to oxygen, carboxyhemoglobin will not transport inhaled oxygen from the lungs to the rest of the body. As the level of carboxyhemoglobin increases in the bloodstream, carbon monoxide poisoning and/or death may result. Elevated levels of carboxyhemoglobin in the blood can initiate a heart attack or other cardiovascular symptoms, such as chest pains.

Permissible Exposure Levels

The MIOSHA Occupational Health Standard, Air Contaminants, Part 301 exposure limits for MC:

- Permissible Exposure Limit (PEL) = 25 ppm (8-hour TWA)
- Short-term Exposure Limit (STEL) = 125 ppm (15 min.)

The NIOSH Immediately Dangerous to Life and Health (IDLH) value is 2,300 ppm. IDLH values specifically refers to the acute respiratory exposure that poses an immediate threat of loss of life, immediate or delayed irreversible adverse effects on health, or acute eye exposure that would prevent escape from a hazardous atmosphere.

INVESTIGATION

The decedent arrived at the apartment complex at approximately 9:30 a.m. and spoke with two apartment maintenance personnel for five to ten minutes. They reviewed the scope of work to be performed – two apartments required tub resurfacing. The decedent gathered his tools and proceeded to the first apartment.

MIOSHA measured a similar bathroom and tub in another apartment. The bathroom was approximately 59 inches wide by 94 inches long by 96 inches in height (floor to ceiling). The bathroom contained a 50 cfm ceiling bathroom ventilation fan. The bathroom tub was measured as 57 inches long and 29 inches wide and was located “behind” the bathroom door, which opened into the bathroom (Figures 1 and 6).

The incident bathroom had a heating/cooling vent, but it is unknown how frequently the apartment furnace cycled, and therefore, unknown how much fresh air was provided and the amount of mixing/circulation of the air in the space.

To perform the bathtub work, the decedent had to be positioned behind the door and was thus required to almost close the bathroom door; it was open approximately one inch when he was found. He poured the Tal-Strip® II (Figure 6) into the tub and spread it in the tub with the 4-inch paintbrush. He most likely did not turn the ceiling exhaust fan “ON”. Either prior to pouring and spreading the Tal-Strip® II or to scraping, the decedent donned his latex gloves (Figure 7). The decedent did not bring his respiratory equipment to the apartment.

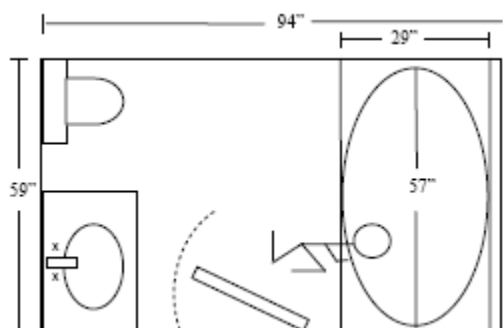

Figure 6. Drawing of incident bathroom – Not to Scale



Figure 7. Type of glove worn by decedent

At approximately 11:10 a.m., one of the apartment maintenance personnel realized the decedent was given a wrong apartment number. He went to the apartment whose number was incorrectly given to the decedent. He found that no work had yet been performed in this apartment, so he attempted to contact the decedent via his cell phone. When the decedent's phone went to voice mail, he went to the incident apartment at approximately 11:20 a.m. He entered the apartment and called the decedent's name. Continuing into the apartment, he found the decedent in the bathroom on his knees leaning over the bathtub with his head in the tub (Figures 1 and 5). He called his name again, shook him, and received no response. He called for emergency response, and then called another maintenance person (Maintenance #2).

Maintenance #2 was instructed to inform the property manager of the situation. After speaking with the property manager, he then went to the apartment where the incident occurred. The workers pushed open the bathroom door, and Maintenance #2 checked for a pulse and airway blockage. The decedent was sweaty and cold to the touch. The workers pulled the decedent from the bathtub and laid him on the bathroom floor. Maintenance #2, who indicated in the police report that he was a certified EMT, began chest compressions. Emergency response arrived and pulled the deceased from the bathroom into the living room to continue resuscitative efforts.



Figure 8. Amount of work completed by decedent when found by maintenance

The police report indicated that maintenance personnel estimated that the decedent had completed approximately one hour's worth of work (Figure 8). Conflicting information regarding the status of fan operation was identified. Both maintenance and the responding police indicate that the fan was "OFF". In the police report, maintenance personnel stated that they did not turn the fan "ON". When MIOSHA interviewed the emergency responders, they indicated the fan was "ON".

It is unknown how much product was in the Tal-Strip® II container at the start of the job or how much of the product was used. The responding police department and MIOSHA determined that there were eight ounces of 128 ounces left in the container.

The police report indicated that the decedent's wife stated that her husband worked with very "caustic" substances and it was common for him to feel light-headed or dizzy while he was on a job. The decedent would call her occasionally and ask her to bring his "breathing apparatus" to him. When he called her, she instructed him to sit by a window to get fresh air until she arrived. His wife also indicated that he "was used to many strong fumes because of his profession". The decedent's vehicle was nearby. With consent, the police department inspected the inside of the decedent's vehicle and did not locate a breathing apparatus. The police department noted "very strong smelling fumes" inside the vehicle.

Exposure Calculations

The Tal-Strip® II Aircraft Coating Remover MSDS indicated the product had a MC percentage by weight of 60%-100%. The owner indicated that decedent usually used approximately six ounces of product per application (128 ounce container would last 10 multi-strips or 20 single strips). MIFACE calculated theoretical vapor levels (in parts per million (ppm)) the decedent inhaled for six ounces of MC at each end of the range of the MC (60% and 100%) and, because MC is heavier than air, for different volumes (concentration in the entire bathroom and in the tub). The calculations are shown in Appendix A.

All of the calculations showed the decedent was exposed to MC vapors in excess of the MIOSHA PEL (25 ppm) and STEL (125 ppm) and NIOSH IDLH (2,300 ppm).

If the decedent worked for approximately one hour (per maintenance worker assessment of the progress of the tub refinishing), the calculations estimated the decedent as he bent over the tub was exposed to vapors in excess of the MIOSHA PEL (25 ppm) and STEL (125 ppm) and NIOSH IDLH (2,300 ppm).

TWA Exposure: Based on 1-hour exposure

Amount of Product Used	MC Concentration	TWA Exposure Room (ppm)	TWA Exposure Tub (ppm)
6 oz	100%	1,062	19,364
	60%	637	11,618

Utilizing the calculated MC vapor levels in the bathtub, and using an average of 80% MC, the average tub MC ppm was 123,933 (See Appendix A). This means that, in the tub, MC vapor comprised 12.39% of the air in the tub. The atmosphere in the tub volume with respect to uncontaminated air was $100\% - 12.39\% = 87.61\%$ air. The amount of oxygen that was left in an atmosphere extremely rich in MC vapor was $20.95\% \text{ O}_2 \times 0.8761 = 18.35\% \text{ O}_2$. An 18.35% O_2 atmosphere is considered an oxygen-deficient atmosphere, and when combined with a very high solvent vapor level is an additive toxicity IDLH mixture. Performing work in the oxygen deficient atmosphere that contained such a high level of MC vapor most likely caused the decedent to have a higher respiratory rate, be overcome by the MC and fall forward into the tub.

CAUSE OF DEATH

The death certificate stated the cause of death was sudden cardio-respiratory arrest due to or as a consequence of inhalation of toxic fumes. The decedent had atherosclerotic cardiovascular disease, described as mild by the medical examiner. He had no history of a prior heart attack or asthma. He was taking medication for high cholesterol. Autopsy findings included “heavy congested lungs with mucus plugging” and an elevated methylene chloride concentration (50 mg/l), which was consistent with inhalation of toxic fumes. The blood analysis was negative for carboxyhemoglobin. Toxicology was negative for illegal drugs. The decedent’s smoking history was unknown.

RECOMMENDATIONS/DISCUSSION

Bathtub/tile refinishers should:

- Use alternative stripping methods, such as sanding or strippers that do not contain methylene chloride or acids. Read and follow all label and Material Safety Data Sheet (MSDS) instructions for use.

Bathtub/tile refinishers should determine if stripping products that do not contain MC and acids are effective for stripping in residential environments, and if so, use these products instead of MC-based products. The user should read the product label and follow the safe use recommendations (such as ventilation, personal protective equipment, storage, etc) on the MSDS.

MIFACE contacted several manufacturers of stripping products that did not contain MC or acids, and could be effective substitutes for stripping tubs and tile. Three manufacturers contacted by MIFACE included:

- Ecoprocote (<http://www.ecoprocote.com/>): Soy-It Polyurethane Stripper
 - Molecular-Tech (http://www.m-tc.com/efs2500_home.htm): EFS-2500 Gel
 - Dumond Chemicals Inc (<http://www.dumondchemicals.com/smart-strip.htm>): Smart Strip
- Implement a push-pull (fresh air and local exhaust) ventilation system if using MC-based strippers to reduce the airborne concentration of MC.

Good industrial hygiene and safety practices recommend that engineering controls, such as material substitution and ventilation be used to reduce airborne concentrations to the permissible exposure level. If engineering controls and work practice controls are not feasible or are in the process of being installed or cannot reduce the airborne concentration of MC to permissible exposure levels, then respirators may be used. Per the Methylene Chloride Standard requirements, employers should use ventilation to reduce the air concentration of MC if the level is determined to be above the action level of 12.5 ppm calculated as an 8-hour TWA.

The owner MIFACE interviewed indicated that training consisted of not turning on the bathroom ceiling fan. MIFACE recommends that workers turn on the fan as it promotes air flow from the floor vent toward the ceiling fan.

MIFACE recommends supplying sufficient uncontaminated fresh air and exhausting the MC vapor from the room and to the outdoors.

When possible, on one side of the bathroom, place a fan to introduce fresh, uncontaminated air into the bathroom. To exhaust (remove) the contaminated air from the bathroom, attach MC impermeable ductwork to the intake side of a portable exhaust fan/blower. Place the ductwork inside and as close as possible to the base of the tub. Place the exhaust fan in a bathroom window, or if no window is available, place the fan near the bathroom door. If placing near the door, ensure ductwork is placed on the exhaust side to move the vapors outside. Placing the ductwork inside of the tub expedites MC vapors (which are heavier than air) removal so when

leaning into the tub to apply and scraping product, the bathtub refinisher is not positioned directly into a high MC concentration. MIFACE found blower units with canisters made of lightweight materials, handles for easy carrying, and quick connect clipping systems to permit users to attach ductwork to the input side for vapor extraction and/or on the output side for ventilation.

The MIFACE calculations of the theoretical MC airborne concentration and Washington State's Department of Labor and Industries Division of Occupational Safety and Health (DOSH) monitoring results (see next Recommendation) demonstrate the ease with which MC vapor may accumulate within a bathroom to the level of an IDLH atmosphere. **Using ventilation to reduce the concentration of MC vapor in the air to below IDLH values has the added benefit of not having to comply with extensive MIOSHA Respiratory Protection Standard requirements.** MIOSHA adopted the federal OSHA Respiratory Protection standard requirements. When an IDLH atmosphere is present where work must be performed, the MIOSHA Respiratory Protection Standard requires that the employer provide either a:

- (A) A full facepiece pressure demand self-contained breathing apparatus (SCBA) certified by NIOSH for a minimum service life of thirty minutes, or
- (B) A combination full facepiece pressure demand supplied-air respirator (SAR) with auxiliary self-contained air supply.

Additionally, if an IDLH atmosphere is present, the MIOSHA Respiratory Protection Standard requires many additional actions, including but not limited to one or more individuals outside the IDLH atmosphere; communication between the individual working in the IDLH space and the individual outside the IDLH space, training for the individual outside of the IDLH space to provide emergency response, and pressure demand or other positive pressure SCBAs, or a pressure demand or other positive pressure supplied-air respirator with auxiliary SCBA for the individual outside of the IDLH space.

- Always use a NIOSH-approved full facepiece pressure demand, supplied-air respirator (fresh air system) when using MC-based products due to MC's classification as a carcinogen and the individual's exposure to potential life threatening levels above the Permissible Exposure Limit (PEL) and Short Term Exposure Limit (STEL). A written respiratory protection program should be developed and implemented.

Because MC is a potential human carcinogen, bathtub/tile refinishers who use MC-based products should take extra precautions to minimize exposure and protect themselves. MIFACE recommends that refinishers use a NIOSH-approved full facepiece pressure demand, supplied-air respirator when applying and scraping a MC-based stripper from the tub. The owner MIFACE spoke with had a half-face air-purifying respirator. A half-face air-purifying respirator only offers a protection factor of 10, which limits its applicability when airborne levels are high, as can be found in small work spaces, such as bathrooms with inadequate ventilation. **Air-purifying respirators are not permitted under the MC Standard because they do not provide adequate respiratory protection against MC.**

Washington State's Department of Labor and Industries Division of Occupational Safety and Health (DOSH) inspection data includes a case of a high MC exposure while stripping a bathtub.

A bathtub refinishing employee was monitored while stripping a residential bathtub with *Kleen Strip Aircraft Remover*. The MSDS indicated the product contained less than 85% MC. Information sheets with the product recommended the use of supplied air. The employee had purchased ventilation equipment which was in use at the time of monitoring. The employee wore a half-face air purifying respirator. The table below summarizes the MC samples taken during the stripping task:

	MC, ppm	Type	STEL
Sample 1	2180	personal	125
Sample 2	2000	personal	125
Sample 1	545	area	125
Sample 2	314	area	125

The personal samples were taken in the breathing zone of the employee for 15 minutes. Note that all of the samples significantly exceeded the STEL of 125 ppm, and the two breathing zone samples were close to the NIOSH IDLH value of 2,300 ppm.

If an employee's exposure is likely to exceed the PEL and STEL, MIOSHA requires that the employer provide respirators at no cost to each affected employee and ensure their use. Appropriate respiratory protection varies with exposure levels. A supplied air (SAR) or atmosphere-supplying respirator (or airline respirator) is a respirator for which the source of breathing air is not designed to be carried by the user.

Table 2 on page 13 was reproduced from the MIOSHA Methylene Chloride Occupational Health Standard, Part 313 and shows the respiratory protection equipment required when an individual's exposure exceeds the PEL and STEL values.

Respirator definitions in Table 2:

- Demand Respirator: SAR that admits breathing air to the facepiece only when a negative pressure is created inside the facepiece by inhalation.
- Positive Pressure Respirator: respirator in which the pressure inside the respirator exceeds the ambient air pressure outside the respirator.
- Pressure Demand Respirator: positive pressure SAR that admits breathing air to the facepiece when the positive pressure is reduced inside the facepiece by inhalation.
- SCBA: Self-contained breathing apparatus- SAR for which the breathing air source is designed to be carried by the user.

Table 2: Minimum Requirements for Respiratory Protection for Airborne MC	
<i>MC Airborne Concentration (ppm) or Condition of Use</i>	<i>Minimum Respirator Required*</i>
Up to 625 ppm (25 X PEL)	Continuous flow supplied-air respirator, hood, or helmet
Up to 1,250 ppm (50 X PEL)	(1) Full facepiece supplied-air respirator operated in negative-pressure (demand) mode (2) Full facepiece self-contained breathing apparatus (SCBA) operated in negative-pressure (demand) mode
Up to 5,000 ppm (200 X PEL)	(1) Continuous flow supplied-air respirator, full facepiece (2) Pressure demand supplied-air respirator, full facepiece (3) Positive-pressure full facepiece SCBA
Unknown concentration, or above 5,000 ppm (Greater than 200 X PEL)	(1) Positive-pressure full facepiece SCBA (2) Full facepiece pressure (demand) supplied-air respirator with an auxiliary self-contained air supply
Firefighting	Positive-pressure full facepiece SCBA
Emergency Escape	(1) Any continuous flow or pressure-demand SCBA (2) Gas mask with organic vapor canister

*Respirators assigned for higher airborne concentrations may be used at the lower concentrations.

Supplied-air respirators (SARs) supply clean air from a compressed air, compressed oxygen, liquid air or liquid oxygen. Note that a SAR does not obtain air from the work area but from an independent source. Both the federal OSHA and MIOSHA Respiratory Protection standards detail specifications for the air supplied to the SAR. The information below highlights some of the specifications.

- *Compressed breathing air* shall meet at least the requirements for Grade D breathing air described in ANSI/Compressed Gas Association Commodity Specification for Air, G-7.1-1989 to include:
 - o Oxygen content (v/v) of 19.5%-23.5%;
 - o Hydrocarbon (condensed) content of 6 milligrams per cubic meter of air or less;
 - o Carbon monoxide (CO) content of 10 ppm or less;
 - o Carbon dioxide content of 1,000 ppm or less; and
 - o Lack of noticeable odor.

- *Compressors used to supply breathing air* to respirators are constructed and situated so as to:
 - o Prevent entry of contaminated air into the air supply system;
 - o Minimize moisture content so that the dew point at 1 atmosphere is 10 degrees F below the ambient temperature;
 - o Have a suitable in-line air-purifying sorbent beds and filters to further ensure breathing air quality. Sorbent beds and filters shall be maintained and replaced or refurbished periodically following the manufacturer's instructions
 - o Have a tag containing the most recent change date and signature of the person authorized by the employer to perform the change. The tag shall be maintained at the compressor.
 - o *Compressors not oil-lubricated*: the employer shall ensure that carbon monoxide levels in the breathing air do not exceed 10 ppm.
 - o *Oil-lubricated compressors*: the employer shall use a high-temperature or carbon monoxide alarm or both to monitor carbon monoxide levels. If only high temperature alarms are used, the air supply shall be monitored at intervals sufficient to prevent carbon monoxide in the breathing air from exceeding 10 ppm.

Another compelling reason to use a supplied air respirator is that the odor threshold of MC is higher than the recommended exposure limit. An odor threshold is the lowest airborne concentration that can be detected by a population of individuals. While odor thresholds can serve as useful warning properties, they must be used cautiously because olfactory perception varies among individuals.

The OSHA Substance Safety Data Sheet and Technical Guidelines for MC section for Odor Threshold states: "Different authors have reported varying odor thresholds for MC. Kirk-Othmer and Sax both reported 25 to 50 ppm; Summer and May both reported 150 ppm; Spector reports 320 ppm. Patty, however, states that since one can become adapted to the odor, MC should not be considered to have adequate warning properties."

The owner MIFACE spoke with indicated he used detection of the MC odor as an indication that his respirator was leaking. Although it is commendable that he would readjust his respirator upon detecting the MC odor, it is unknown as to what the MC concentration was in the air when he detected it, whether he had adapted to it, and consequently, to how long a period of time he was exposed.

In addition to using the proper respiratory protection, refinishers should develop and implement a written respiratory protection program which includes regular training, maintenance, inspection, cleaning, medical evaluation, and fit testing.

- Develop and implement a Methylene Chloride exposure management plan that addresses the requirements of MIOSHA's Methylene Chloride Occupational Health Standard Part 313 if using a MC-based stripper.

Although a MC Exposure Management Plan is not required by MIOSHA, its development and implementation would assist an employer who has employees exposed or potentially exposed to MC, its solutions, and vapor-releasing materials to meet the requirements of Part 313. The plan should include a summary of permissible exposure levels, exposure monitoring and training, medical surveillance and medical removal, record keeping, regulated areas, hazard communication, employee information and training, emergency procedures, primary reliance on engineering and work practices to control exposure, and maintenance and selection of personal protective equipment.

The development and implementation of the MC exposure management plan should reference the following employer-specific written safety and health programs as required under MIOSHA standards:

- ✓ Right To Know/Hazard Communication (MIOSHA Occupational Health Standard, Part 430, 1910.1200)
- ✓ Respiratory Protection (MIOSHA Occupational Health Standard, Part 451, 29 CFR 1910.134)
- ✓ Personal Protective Equipment (MIOSHA Construction Safety Standard, Part 6)
- ✓ Employee Exposure Records and Trade Secrets (MIOSHA Occupational Health Standard, Part 470)

Sample MC exposure plans may be found on the Internet at:

- ✓ Tufts University: <http://publicsafety.tufts.edu/ehs/?pid=11>
 - ✓ University of Maryland: <http://www.des.umd.edu/os/mngmt/methylenechloride.html>
 - ✓ Arizona State University: http://www.asu.edu/uagc/EHS/documents/asu_methylene_chloride_exposure_management_plan.pdf
- Conduct employee time weighted average (TWA) exposure monitoring as part of the Methylene Chloride Exposure Plan and in compliance with MIOSHA's Methylene Chloride Occupational Health Standard, Part 313 and institute appropriate engineering, administrative and personal protective equipment control measures based on the monitoring results.

The MIOSHA MC standard Part 313 requires an employer to conduct air monitoring in the employee's breathing zone to characterize an employee's MC exposure. Appendix A, Section VIII Monitoring and Measurement Procedures of Part 313 identify the options to determine an 8-hour employee exposure. Sampling and analysis under this section may be performed by collection of the MC vapor on two charcoal adsorption tubes in series or other composition adsorption tubes, with subsequent chemical analysis. Sampling and analysis may also be performed by instruments such as real-time continuous monitoring systems, portable direct reading instruments, or passive dosimeters as long as measurements taken using these methods accurately evaluate the concentration of MC in employees' breathing zones.

A passive dosimeter is an organic vapor passive monitoring badge that can be attached to an individual's work garment in his/her breathing zone to quantify the air concentration of MC to which the worker is exposed. Employers should ensure that the badge brand used meets or exceeds the OSHA accuracy requirements as defined in the standard. Employers can purchase passive dosimeter from many sources on the Internet; one source is Lab Safety Supply (http://www.labsafety.com/personal-organic-vapor-monitor-methylene-chloride-tlv-50-ppm-sensitivity-002-ppm-pkg-of-4_s_25352/)

Exposure monitoring permits an employer to comply with other standard requirements, such as medical surveillance. **An employer is required to offer a worker the opportunity to participate in a medical surveillance program if the worker is exposed to MC at concentrations at or above the action level (12.5 ppm 8- hour TWA or 125 ppm 15- minute STEL) for more than 10 days a year.** If the worker is exposed to MC at concentrations over either of the PELs, the employer is also required to have a physician or other licensed health care professional ensure that the worker is able to wear the assigned respirator. The employer must provide all medical examinations relating to the worker's MC exposure at a reasonable time and place and at no cost to the worker.

MIOSHA Consultation, Education and Training Division (CET) staff offers free statewide safety and health assistance to employers and employees. A staff of experienced, professional occupational safety experts, construction safety consultants, and industrial hygienists can provide a wide range of customized services, such as assisting with air monitoring. Additionally, MIOSHA CET's Self-Help Program assists employers in conducting their own evaluations of hazardous exposures in their workplaces. This free service provides limited technical industrial hygiene guidance, monitoring and measuring equipment, sample analyses and general information. To get the most benefit from the program, employers must be trained to use the equipment and must be sufficiently familiar with the health hazards. Contact MIOSHA CET at (517) 322-1809.

- Perform on-the-spot air monitoring to provide immediate feedback to determine the effectiveness of implemented ventilation.

Methylene chloride (dichloromethane) portable gas detection kits that utilize detector tubes can be purchased to provide an inexpensive method to approximate the level of MC in the air. A hand-held sampling pump draws a consistent amount of air through the detector tube which shows a color change based on the concentration of MC in the air, thus providing the user immediate feedback regarding the MC air concentration. Detector tubes are not permitted under the MC standard to quantify a worker's exposure, but could be used to approximate the effectiveness of the ventilation used.

Each manufacturer (for example, Draeger, Sensidyne, MSA, Gastec, RAE Systems) of the hand-held sampling pump has its own set of detector tubes – tubes and pumps are not interchangeable. The detector tube kits (hand-held pumps and detector tubes) can be purchased through various suppliers, such as Lab Safety Supply (<http://www.labsafety.com/safety-supplies/air-monitors-24417104/>), Pro Safety Supplies (<http://www.prosafety.com/>), or Argus-HAZCO (<http://argus-hazco.com/>).

- Select and wear appropriate personal protective equipment, including face protection and gloves based upon the work operations to be performed and the product’s Material Safety Data Sheet (MSDS).

The MSDS for Tal-Strip® II recommended the use of a full face shield, safety glasses with side shields and indirect vented goggles, as well as butyl rubber or polyvinyl alcohol (PVA) gloves. MIOSHA Construction Health Standard, Personal Protective Equipment, Part 6 requires that personal protective equipment should be selected and worn based upon the work to be performed and its associated hazards and should be identified in the firm’s accident prevention program.

The decedent would wear either nitrile or latex gloves – these gloves were insufficient to protect his skin while working with Tal-Strip® II. In the case of Tal-Strip® II, the manufacturer identified the appropriate glove type. Sometimes, manufacturers will state on the MSDS to use a “protective glove”. When the MSDS does not identify specific glove composition, there are other resources available to help the product user identify the appropriate glove. Chemical compatibility guides for protective gloves can be found on many glove manufacturer websites. Lab Safety Supply lists internet links for chemical compatibility guides of the larger glove manufacturers at <http://www.labsafety.com/refinfo/ezfacts/ezf166.htm#links>.

- Determine and implement safe work practices to reduce exposure.

Bathtubtile refinishers must use a combination of controls (substitution, ventilation, personal protective equipment and work practices) to prevent overexposure.

As an example, refinishers should purchase/modify the paintbrush (if used) and scraper. The decedent’s work practice was to utilize a 4-inch paintbrush with a standard-sized handle (Figure 1). Employers/workers should consider adding an extender to the tool or purchase tools with longer 12-inch handles to minimize the worker’s exposure by reducing the bending/leaning into the tub. An example tool is shown in Figure 9 (Picture courtesy of BigPaintStore.com)



Figure 9. Example of long-handled scraper

If using a MC-based stripper, at a minimum you must do the following to protect yourself from being overcome by the vapors - these actions may not be enough to protect you from MC’s long-term health effects:

- **Establish fresh makeup air and local exhaust ventilation. Fresh air:** Place a fan in a window or doorway. **Local Exhaust:** Attach ductwork to another fan. Place the ductwork in the tub. Place fan end at window or door to exhaust MC vapors **to the outside of building.** Ceiling fans alone are insufficient.
- **Wear a tight-fitting pressure-demand full-face air supplied respirator** when applying and removing the MC-based stripper. **Dust masks and cartridge respirators DO NOT protect you.**
- **Leave the room** after MC stripper application. Keep fresh air and local exhaust fans running and windows and doors open.

- Use **butyl rubber or polyvinyl alcohol (PVA) gloves**. Latex or nitrile gloves DO NOT protect you.
- **Implement safe work practices** such as: add a tool handle extender to minimize leaning into the tub.

Manufacturers/distributors of aircraft-grade MC-based stripping products whose product is intended for the aircraft and/or other industries but are being used in bathroom/kitchen tub, sink, and tile refinishing industry should:

- Provide additional labeling and educational outreach regarding safe use of their products and consider ways to restrict their use so that it cannot be used in the bathtub refinishing industry.

Many tub/sink/tile refinishers are self employed or are a small business. Many of the tub refinishing websites viewed by MIFACE during the writing of this report were posted by small businesses and highlighted the usefulness of aircraft-grade MC-based stripping products as a stripper, and the procedures and process involved in refinishing. Few websites mentioned the health hazards, personal protective equipment to be used, ventilation requirements, etc.

Aircraft-grade strippers are designed to be used on aircraft, usually in substantially larger spaces (aircraft hangars or outside) rather than in smaller residential spaces such as bathrooms or kitchens. As a low cost and effective stripper, MC will most likely continue to be used in the bathtub/tile refinishing industry. Manufacturers/distributors of the aircraft-grade strippers containing MC should target the tub/tile/sink refinishing industry with outreach efforts to promote understanding of the health effects of MC exposure and its safe use.

REFERENCES

MIOSHA standards cited in this report may be found at and downloaded from the MIOSHA, Michigan Department of Licensing and Regulatory Affairs (MDLARA) website at: www.michigan.gov/mioshastandards. MIOSHA standards are available for a fee by writing to: Michigan Department of Licensing and Regulatory Affairs, MIOSHA Standards Section, P.O. Box 30643, Lansing, Michigan 48909-8143 or calling (517) 322-1845.

- MIOSHA Occupational Health Standard, MC, Part 313
- MIOSHA Occupational Health Standard, Hazard Communication, Part 430
- MIOSHA Construction Safety and Health Standard, General Rules, Part 1
- MIOSHA Occupational Health Standard, Respiratory Protection Part 451
- MIOSHA Construction Safety Standard, Personal Protective Equipment Part 6
- MIOSHA Occupational Health Standard, Employee Exposure Records and Trade Secrets, Part 470
- MIOSHA Occupational Health Standard, Air Contaminants, Part 301
- OSHA Substance Safety Data Sheet and Technical Guidelines for MC. http://www.osha.gov/pls/oshaweb/owadis.show_document?p_table=STANDARDS&p_id=10095
- OSHA Safety and Health Topics: MC. <http://www.osha.gov/SLTC/methylenechloride/>

- NIOSH Workplace Safety and Health Topics – MC. <http://www.cdc.gov/niosh/topics/methylenechloride/>
- NIOSH Pocket Guide to Chemical Hazards, Appendix E – OSHA Respirator Requirements for Selected Chemicals. <http://www.cdc.gov/niosh/npg/nengapdx.html>
- MSDS HyperGlossary. <http://www.ilpi.com/msds/ref/index.html> . Referenced from Michigan State University Office of Radiation, Chemical, and Biological Safety, http://www.orcbs.msu.edu/msds/msds_toc.htm
- Lofgren, Don J., Reeb-Whitaker, Carolyn K., Adams, Darrin. Surveillance of Washington OSHA Exposure Data to Identify Uncharacterized or Emerging Occupational Health Hazards. Journal of Occupational and Environmental Hygiene, 7:375-388
- MC Facts No. 9: Suggested Work Practices for Cold Degreasing and Other Cold Cleaning Operations. Small Entity Compliance Guide Fact Sheet. Federal OSHA. <http://www.osha.gov/SLTC/methylenechloride/factsheets/mcfsno9.html>

Key Words: Methylene chloride, toxic exposure, bathtub refinishing

MIFACE (Michigan Fatality Assessment and Control Evaluation), Michigan State University (MSU) Occupational & Environmental Medicine, 117 West Fee Hall, East Lansing, Michigan 48824-1315; <http://www.oem.msu.edu>. This information is for educational purposes only. This MIFACE report becomes public property upon publication and may be printed verbatim with credit to MSU. Reprinting cannot be used to endorse or advertise a commercial product or company. All rights reserved. MSU is an affirmative-action, equal opportunity institution.

10/26/2011

APPENDIX A

Calculations

Density (D) of MC = 1.325 g/ml

Molecular weight (MW) = 84.94 g/mol

One mole of Gas at Standard Temperature and Pressure = 22.4 l/mol

Assume Standard Temperature and Pressure (STP) = 1

Volume of Chamber:

Room = 308 ft³ or 8.7m³

Allowing 15% of the space for fixtures and the decedent, Room = 7.4 m³

Bath tub = 14.35 ft³ or 0.406 m³

Volume of Chamber in Liters (L):

Room = 7.4m³ x 1000 l/m³ = 7400 L

Bath tub = 0.406 m³ x 1000 l/m³ = 406 L

Volume of Tal-Strip® II (Vml):

6 oz. = 0.18 L = 180 ml

Equations

$$\text{Liters of Pure Vapor (PV)} = \frac{(\text{Vml}) (\text{D}) (22.4 \text{ l/mol})}{\text{MW}} \times \text{STP}$$

$$\text{Room or Tub Concentration (ppm)} = \frac{\text{PV}}{\text{L}} \times 10^6$$

Amount of Product Used	MC Concentration	Room Concentration (ppm)	Tub Concentration (ppm)
6 oz	100%	8,499	154,916
	60%	5,099	92,949

MIOSHA Part 301, Air Contaminants, Rule 4 – Calculation of Time Weighted Average (TWA)

$$E = (C_1T_1 + C_2T_2 + \dots + C_nT_n) \div 8$$

Where: E = cumulative exposure for an 8-hour work shift

C₁ = substance concentration during the first period of time “T” where the concentration remains constant

C₂ = substance concentration during the second period of time “T” where the concentration remains constant

T = period of time in hours for which the substance concentration “C” remains constant

TWA Exposure: Based on 1-hour exposure

Amount of Product Used	MC Concentration	TWA Exposure Room (ppm)	TWA Exposure Tub (ppm)
6 oz	100%	1,062	19,364
	60%	637	11,618