

RI 8864

Bureau of Mines Report of Investigations/1984

**Electrical Properties and Attenuation
Distance of Upper Pennsylvanian Coal
Measure Rock From Southwestern
Pennsylvania**

By David P. Lindroth, Carl F. Wingquist,
and Andrew L. Dehler



UNITED STATES DEPARTMENT OF THE INTERIOR

RI 8864

Report of Investigations 8864

Electrical Properties and Attenuation Distance of Upper Pennsylvanian Coal Measure Rock From Southwestern Pennsylvania

By David P. Lindroth, Carl F. Wingquist,
and Andrew L. Dehler



UNITED STATES DEPARTMENT OF THE INTERIOR

William P. Clark, Secretary

BUREAU OF MINES

Robert C. Horton, Director

Library of Congress Cataloging in Publication Data:

Lindroth, David P

Electrical properties and attenuation distance of upper Pennsylvanian coal measure rock from southwestern Pennsylvania.

(Report of investigations ; 8864)

Bibliography: p. 14-15.

Supt. of Docs. no.: I 28.23:8864.

1. Rocks--Electric properties. 2. Ground penetrating radar. 3. Coal mines and mining--Pennsylvania--Safety measures. 4. Geology--Pennsylvania. I. Wingquist, Carl F. II. Dehler, Andrew L. III. Title. IV. Series: Report of investigations (United States. Bureau of Mines); 8864.

TN23,U43 [QE431.6,E4] 622s [622'.8] 83-600391

CONTENTS

	<u>Page</u>
Abstract.....	1
Introduction.....	2
Acknowledgments.....	3
Experimental procedure.....	3
Method.....	3
Measurement technique and apparatus.....	3
Rock samples and preparation.....	7
Results.....	10
Discussion.....	11
Conclusions.....	13
References.....	14
Appendix A.--Experimental data.....	16
Appendix B.--Relative dielectric constant and dissipation factor of NBS stan- dard glass.....	27

ILLUSTRATIONS

1. Resonant circuit schematic.....	4
2. Schematic diagram of measuring circuit.....	5
3. Q-meter and sample holder.....	6
4. Geologic column.....	8
5. Disk samples.....	10
6. Relative dielectric constant as a function of depth.....	11
7. Dissipation factor as a function of depth.....	12
8. Attenuation distance as a function of depth and frequency.....	13
9. Rock attenuation distance.....	14

TABLES

A-1. Experimental data.....	17
B-1. Relative dielectric constant and dissipation factor values for NBS stan- dard glass.....	27

UNIT OF MEASURE ABBREVIATIONS USED IN THIS REPORT

°C	degree Celsius	μin	microinch
ft	foot	mm	millimeter
h	hour	pct	percent
in	inch	pF	picofarad
m	meter	s	second
MHz	megahertz	vol pct	volume percent
min	minute	yr	year

ELECTRICAL PROPERTIES AND ATTENUATION DISTANCE OF UPPER PENNSYLVANIAN COAL MEASURE ROCK FROM SOUTHWESTERN PENNSYLVANIA

By David P. Lindroth,¹ Carl F. Wingquist,¹ and Andrew L. Dehler²

ABSTRACT

The Bureau of Mines is engaged in research on ground probing radars for detection of geologic hazards in advance of mining. Penetration distances and interpretation models depend on the dielectric properties and wave propagation characteristics for coal measure stratified media. Relative dielectric constants and dissipation factors were measured under ambient conditions for Pittsburgh Seam coal measure rock over the frequency range of 20 to 100 MHz by the susceptance-variation method. The rock types measured were representative sedimentary rock located above the Pittsburgh Coal Seam. Extreme values for the computed attenuation distance ranged from 1.7 m at 100 MHz for siltstone to 230 m at 20 MHz for a particular limestone.

¹Physicist, Twin Cities Research Center, Bureau of Mines, Minneapolis, MN.

²Mining engineer, Twin Cities Research Center (now with United States Steel Corp., Mt. Iron, MN).

INTRODUCTION

The Bureau of Mines is engaged in research on premining hazard detection under its program of improving the health and safety technology of the minerals industry. In the area of coal mine safety and ground control, premining investigations include the development of ground probing radar primarily for the detection of hazards that may exist in front of the active mining face.

Mining operations, and coal mining operations in particular, are often plagued by adverse ground conditions as a result of the local geology or previous human activity. Common geologic problems are faults, clay veins, channel sand, kettlebottoms, water-filled cavities, seam splits, and rolls. The most common manmade problems that create a hazard are abandoned mine workings and old wells. The hazards are encountered unexpectedly while mining, with serious accidents and loss of life often resulting, owing to inundation, roof falls, and blowouts. Safety data indicate that approximately half the underground coal mine fatalities were associated with ground control problems (1).³

One of the most common and costly current methods of hazard detection is an extensive drilling program. Drilling, however, can miss significant geologic conditions or extensive abandoned workings. Remote geophysical techniques have been applied to mapping and characterization of subsurface geologic conditions by the oil companies for over 50 yr. Mining companies have also utilized geophysics as an exploration tool in the search for metallic ore bodies. For these purposes, geophysics has become a reliable, economic, and valuable tool. While the methods may be similar, the specific application and interpretation of results must vary with the problem. The same is true when the geophysical methods are applied to the problem of hazard detection.

³Underlined numbers in parentheses refer to items in the list of references preceding the appendixes.

Although the application of electromagnetic wave (radar) probing is still in its infancy in mining, an investigation into applications has already begun. These applications include detection of geologic hazards in advance of mining, site characterization and delineation, detection of abandoned well casings, roof fall warning systems, entry stability indicators, pillar and rib failure monitors, and coal bump warning devices. Current techniques include synthetic pulse radar and electromagnetic probing from a single borehole, borehole to surface, surface to borehole, and between two or more boreholes (cross borehole).

The electromagnetic data collected in the field by the different techniques can lead to gross misinterpretation of results without the electromagnetic property data on the coal measure strata for input into interpretive models. Without the requisite data, highly reflective strata are unknown, and wave propagation characteristics and transmission paths for coal measure strata remain empirical. A scarcity of data exists to date on electromagnetic properties of coal measure rocks for the U.S. coalfields. Such pertinent property data should benefit geophysical investigations and future mine design.

Previous laboratory measurements made by Cook (2) on the complex permittivity of mine and tunnel rocks covered the frequency range of 1 to 100 MHz. These measurements were made on rocks having their in situ moisture content. The results predicted that low-loss propagation would be possible in certain limestones and coals. Existing VHF mining radar equipment would be capable of penetrating these materials to distances of hundreds of feet.

Useful but shorter probing distances were predicted for other coals, schists, dry sandstones, and gypsums. Finally, probing distances of less than 10 ft were predicted for most shales, clays, and fine-grained soils. The connate moisture

content was shown to be a governing factor.

Howell and Licastro (3) summarized the dielectric constants for limestones and sandstone in the 1- to 10-MHz range. The values for limestone range from 7 to 10, while for sandstone under vacuum, a value of 5 is obtained, which increases to 8 for 12 pct water saturation. They conclude that below 1 MHz, the moisture in a rock is the dominating factor in determining its dielectric constant, owing to the formation of interfacial polarization along the crystal or rock fragment boundaries.

The dielectric constants and loss tangents over the range 0.05 to 100 MHz for coal and coal measure rock from the Western Donbass were measured by Arsh, Krasin, and Nosov (4). The moisture contents were kept less than 5 pct for the coal and less than 1.5 pct for the rock. At 100 MHz the dielectric constant is less than 6 for all rocks measured, and is about 2 for coal. Larger variations are observed in the loss tangent; coal is the lowest (0.05) and argillite the highest (0.16) at 100 MHz. They conclude that at frequencies of up to 10 MHz, even for high moisture contents, the values of dielectric constant for coal differ from

the dielectric constants of most of the associated rock, and for the loss tangent this difference extends to frequencies of 100 MHz or more.

Geyer and Keller (5), in their study of the "constraints affecting through-the-earth electromagnetic signalling and location techniques," pointed out the necessity for acquiring the electrical properties of the rock overlying the mine workings. They note, however, that the use of existing tabulated data on the electrical properties may not be entirely satisfactory because of the near-surface sedimentary deposition sequence of rocks above the coal. They point out that a significant fraction of the rock overlying a coal mine may have its properties modified by weathering and that relatively few electrical property measurements have been made on such rock sequences.

In order to more clearly define the electrical property values of the coal measure rock, the current measurements were made on drill core taken from above the Pittsburgh Coal Seam in southwestern Pennsylvania. The data presented herein were obtained experimentally from laboratory measurements performed at the Bureau of Mines.

ACKNOWLEDGMENTS

The work of Michael Boucher, geologist, Twin Cities Research Center, in

performing the petrographic analysis is gratefully acknowledged.

EXPERIMENTAL PROCEDURE

METHOD

The susceptance-variation method was used for all measurements. In this method, the width of the response curve of a resonant circuit is a measure of the dissipation factor of the circuit. Dissipation factor is a measure of capacitance and resistance. A measure of the response curve width is the change in the circuit capacitance, which is easily and accurately measured by the calibrated vernier capacitor that is part of the micrometer-electrode sample holder.

MEASUREMENT TECHNIQUE AND APPARATUS

Selection of a technique to measure relative dielectric constant and dissipation factor is dependent on the frequency range of interest. Between 20 and 100 MHz, the frequency range of interest in this study, resonant circuit techniques are applicable. A typical parallel resonant circuit consisting of an inductor (L), variable tuning capacitor (C_T), and sample holder and specimen capacitance (C) is shown in figure 1. Excitation for the circuit is provided by a variable

frequency oscillator connected through coupling capacitor C_1 to point A . Resonance is indicated by a vacuum tube voltmeter (VTVM), V . The disk-shaped sample is clamped between the electrodes of a micrometer-electrode system, which has the advantages of minimizing errors caused by connection lead inductance and resistance and eliminates corrections for ground and connection capacitance. When the sample diameter is chosen to be less than the diameter of the electrodes by five times the sample thickness, edge capacitance corrections are also eliminated.

The specific technique used to measure dissipation factor is known as the susceptance-variation method and is based on the relationship between dissipation factor and the width of the response

curve obtained by detuning the circuit off resonance with a vernier capacitor connected in parallel to the sample electrodes.

The actual measurement procedure involves first setting the generator to the desired frequency and installing an inductor (L) within the tuning range of C_T . The sample is then clamped between the micrometer electrodes, and the circuit tuned to resonance. The Q (voltage) reading is noted, and then, using the vernier capacitor, the circuit is detuned to $0.707 Q$ on both sides of the resonant peak, and the vernier capacitor readings C_1 and C_2 are noted. The vernier capacitor is returned to its original setting and the sample removed. The capacitance lost by removing the sample is regained by reducing the micrometer-electrode

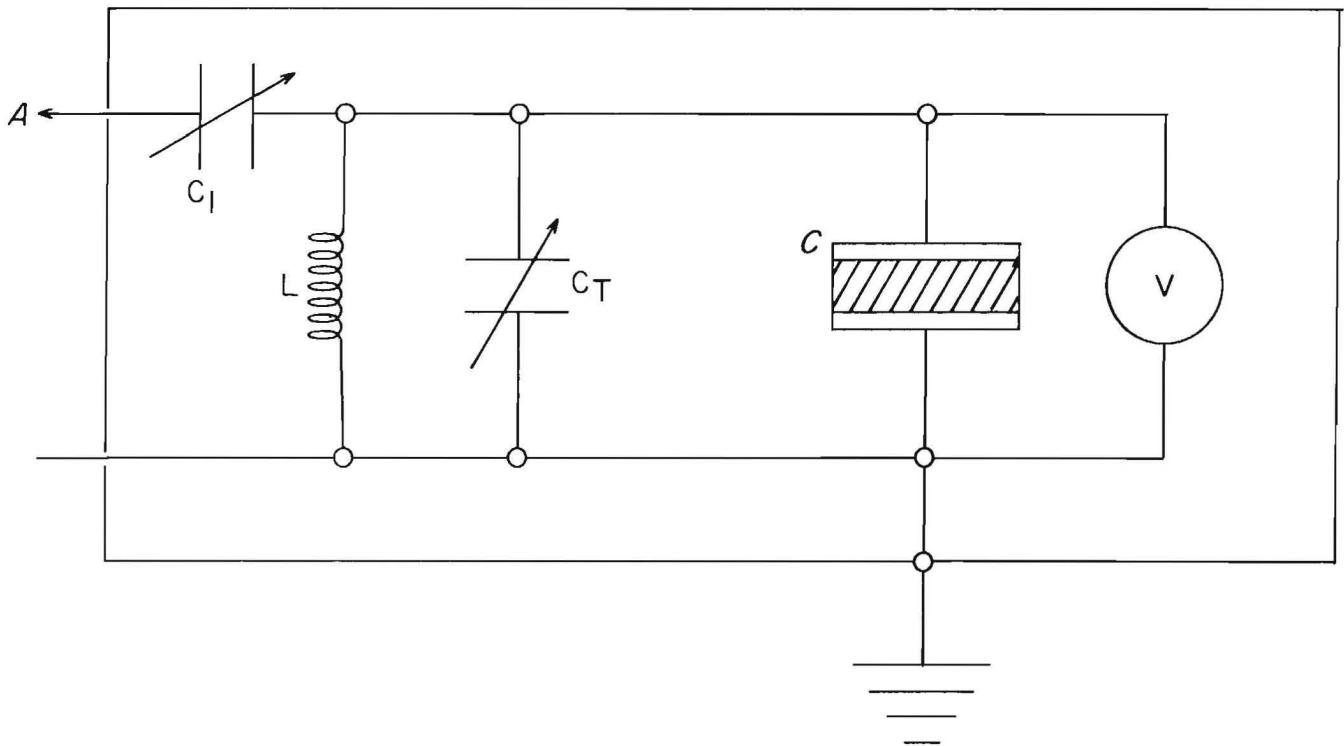

KEY

- | | |
|--------------------------------|------------------------|
| A To generator | C_T Tuning capacitor |
| C Sample holder and specimen | L Standard inductor |
| C_1 Coupling capacitor | V Voltmeter |

FIGURE 1. - Resonant circuit schematic.

spacing until the VTVM again indicates resonance. Then, the electrode spacing and the Q meter reading Q' are noted.

Using correction factors for the various spacings of the electrodes taken from the manufacturer's correction chart, the parallel capacitance, C_p , is found from

$$C_p = C_{A2} + \Delta C_{A2} - \Delta C_{A1} - C_{A1} \left(1 - \frac{A_x}{A_E}\right), \text{ pF,}$$

where C_{A2} = geometric capacitance of the electrodes without the sample in place,

C_{A1} = geometric capacitance of the electrodes at the sample spacing (accounting for any foil or conductive coating),

ΔC_{A2} , ΔC_{A1} = correction factors for C_{A2} and C_{A1} ,

A_x = cross-sectional area of the sample,

and A_E = surface area of the electrodes.

The relative dielectric constant of the sample is then calculated from

$$K = \frac{C_p}{C_{A1} \left(\frac{A_x}{A_E}\right)}.$$

The dissipation factor D is determined by the equation

$$D = \frac{\Delta C(Q' - Q)}{2C_p Q'},$$

where $\Delta C = C_2 - C_1$, $C_2 > C_1$,

with C_1 = capacitance setting below resonance to produce 0.707 Q , where Q is the meter reading at resonance,

and C_2 = capacitance setting above resonance to produce 0.707 Q .

The prime mark indicates readings with the sample removed from the holder and the latter adjusted to reestablish resonance.

The schematic diagram of the actual measuring circuit used is shown in figure 2. The equipment represented by the schematic is depicted in figure 3 and consists of a Boonton model 190-A⁴ Q-meter with standard inductors and a General Radio model 1690A dielectric sample holder (micrometer electrodes).

Various sources for error in the measurements can be identified, including

⁴Reference to specific products does not imply endorsement by the Bureau of Mines.

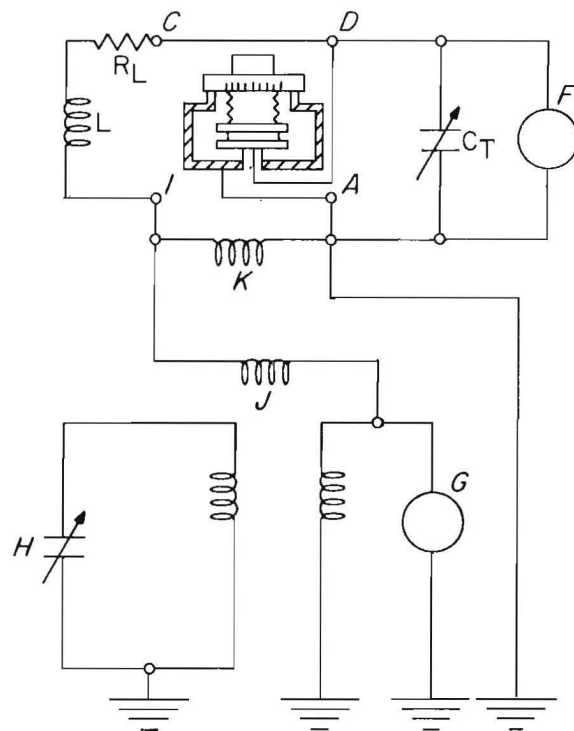

KEY

A	Ground terminal	H	Frequency adjustment
C	High terminal	I	Low terminal
C_T	Tuning capacitor	J	100:1 attenuation
D	Sample holder	K	Injection inductor
F	Q voltmeter	L	Standard inductor
G	XQ voltmeter	R_L	Inductive resistor

FIGURE 2. - Schematic diagram of measuring circuit.

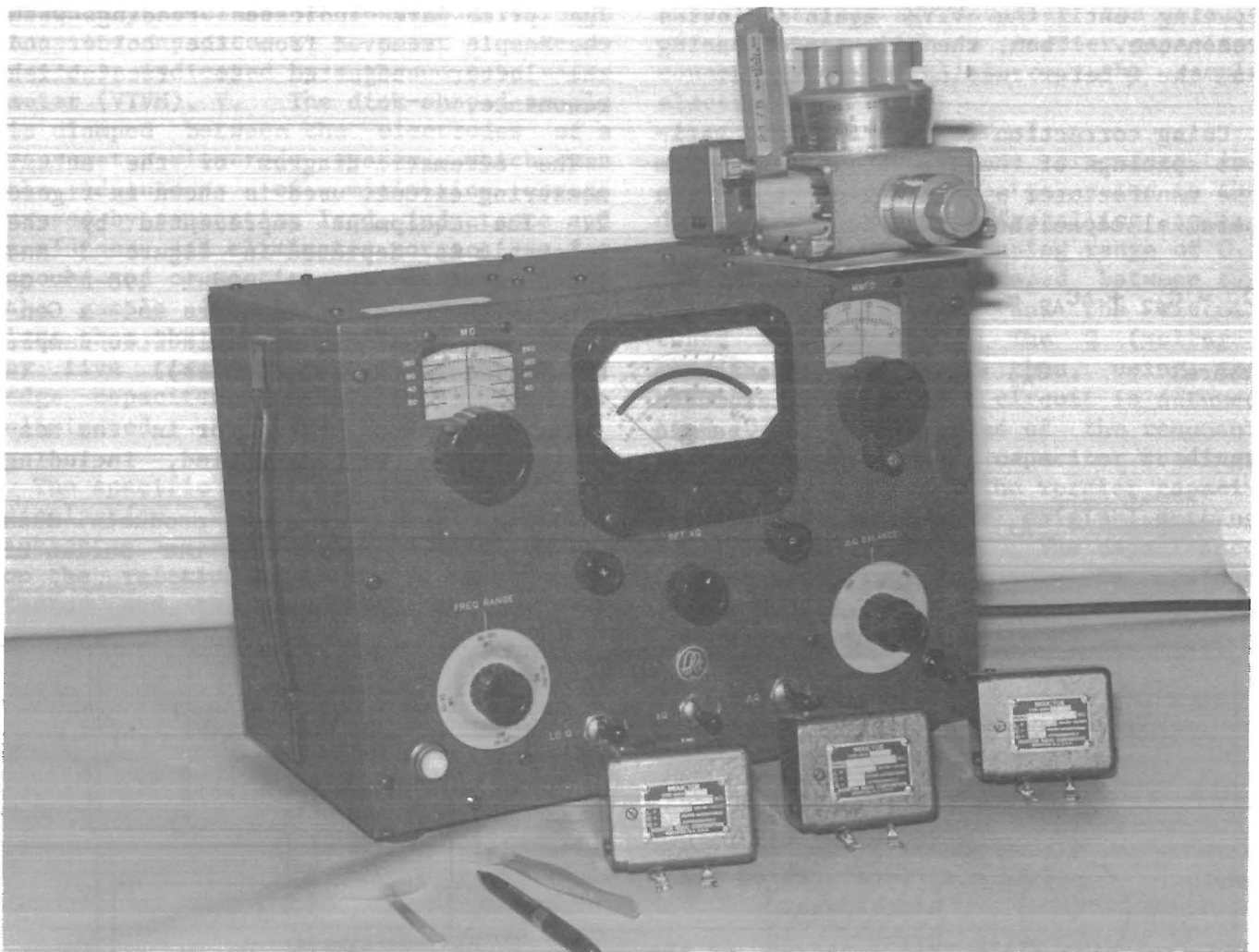

FIGURE 3. - Q-meter and sample holder.

sample dimensions, instrument reading errors, and calibration errors (micrometer-electrode spacing). It is estimated that the data presented in this report are accurate to approximately +2 pct for the dielectric constant and +5 pct for the dissipation factor.

The sample diameter (28.45 mm) was chosen to be smaller than the 50.8-mm-diam electrode by greater than five times the sample thickness (3.99 mm) to eliminate the errors caused by the edge flux when a dielectric is present between the electrodes. A special tool was constructed and used for placing and centering the samples in the electrodes each time a new sample was inserted. Samples were stored in a desiccator between measurements and handled only with

tweezers coated with Teflon fluorocarbon polymer.

Although the electrode surfaces of the sample holder are finished for optical flatness, it was impractical to finish the rock samples to the same degree of flatness. Metal foils or metal paints are commonly used to ensure intimate contact with the dielectric. Thin aluminum foil was used in previous work (6-7) and silver conducting paint was used on the National Bureau of Standards (NBS) standard glass (see appendix B). However, at frequencies above 30 MHz, the use of foil or paints can cause significant errors in dissipation factor measurements on low-loss materials. Therefore, for the highest accuracy, foils or paints should be used only for dielectric constant

measurements and the bare sample surface for dissipation factor measurements. The uncoated rock samples were used in this work as a compromise to minimize the already thousands of measurements required and also to obtain the most accurate dissipation factor values.

At all times during the measurement process, every attempt was made to control humidity. During the summer months when room humidity was approximately 55 to 60 pct, samples were stored in desiccator jars. Because the level of humidity in the jars fell below 20 pct overnight, small amounts of room air (60 pct humidity) were allowed to mix with the dry air in the jar each day prior to taking measurements. Equilibrium was usually reached at 20 to 23 pct in the jar within 1 h and the measurements proceeded.

During the series of measurements, the jar was opened to the atmosphere twice for about 5 s for each disk sample. The samples were exposed to room humidity for about 4 min, and approximately 5 min was required between the measurements of two consecutive samples.

Measurements continued until the humidity gauge in the jar began to rise above the 25-pct level (because of contact with the humid room air). When this was observed, measurements ceased until the level returned to the desired 20- to 23-pct range.

Experimental procedure was modified slightly during the winter to accommodate lower room humidities (30 pct) and to simplify the process. For convenience, samples were still stored in the desiccator jars. Because the humidity inside the jars was about 10 pct and could not be equilibrated to 20 pct using room air in a reasonable length of time, the samples were removed from the desiccator and allowed to equilibrate at room humidities of about 30 pct. Measurements were then taken.

Although some experimental error may have occurred as a result of humidity

changes over the life of the experiment, humidity control and procedure remained constant over a given interval of core and throughout each of the two seasons. It can be concluded that summer measurements occurred with the samples in the 20- to 25-pct humidity range and that winter measurements occurred with samples in the 25- to 35-pct humidity range. In order to clearly define the sample moisture level, the percent of saturation was determined for each core section, after the electrical measurements were completed, at the humidity in which it was measured, and then recorded with the final results. The measured rock moisture content is not the in situ moisture content. The moisture level was determined for the dry samples as follows:

1. Soak representative disk in distilled water for 1 h. Surface dry and weigh on Mettler balance (W_3).
2. Bake disk at 105° C for 2 h.
3. Take out of oven at 50° C and place on Mettler balance.
 - a. Record initial weight (W_1).
 - b. Check weight periodically.
 - c. Record weight when disk equilibrates with room humidity (W_2).

$$W_3 - W_1 = \text{total water,}$$

$$W_2 - W_1 = \text{water absorbed at room humidity,}$$

$$\left(\frac{W_2 - W_1}{W_3 - W_1} \right) \times 100 = \text{percent saturation.}$$

ROCK SAMPLES AND PREPARATION

Approximately 500 ft (154 m) of NX core, 2-1/8 in (53.98 mm) in diameter, was obtained from the Gateway Mine property located in southwestern Pennsylvania. A complete description of the location and geology is given by Mcebs (8). Representative core from each geological horizon was cut into disks 1.12 in (28.45 mm) in diameter and 0.157 in (3.99 mm)

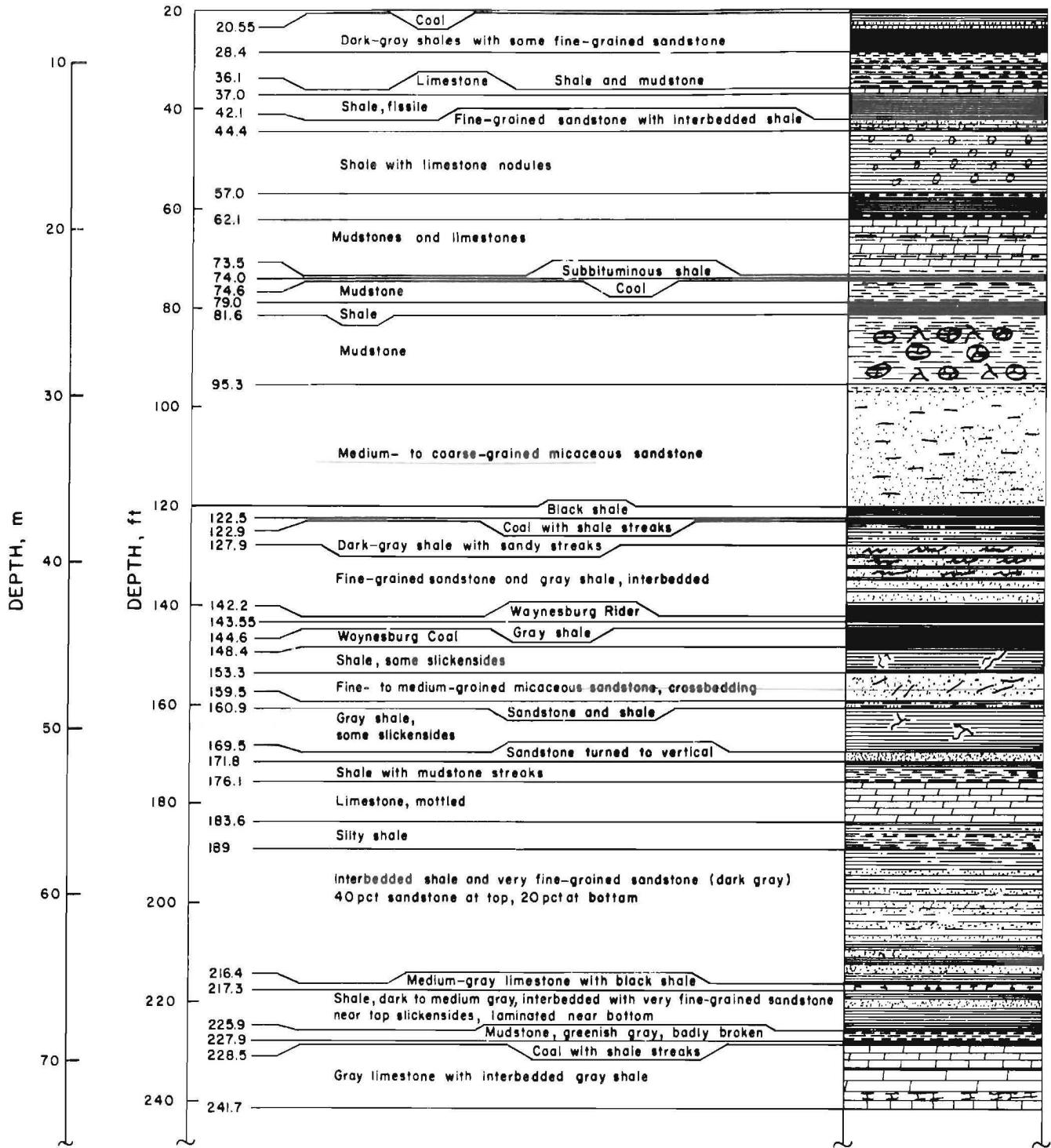

FIGURE 4. - Geologic column.

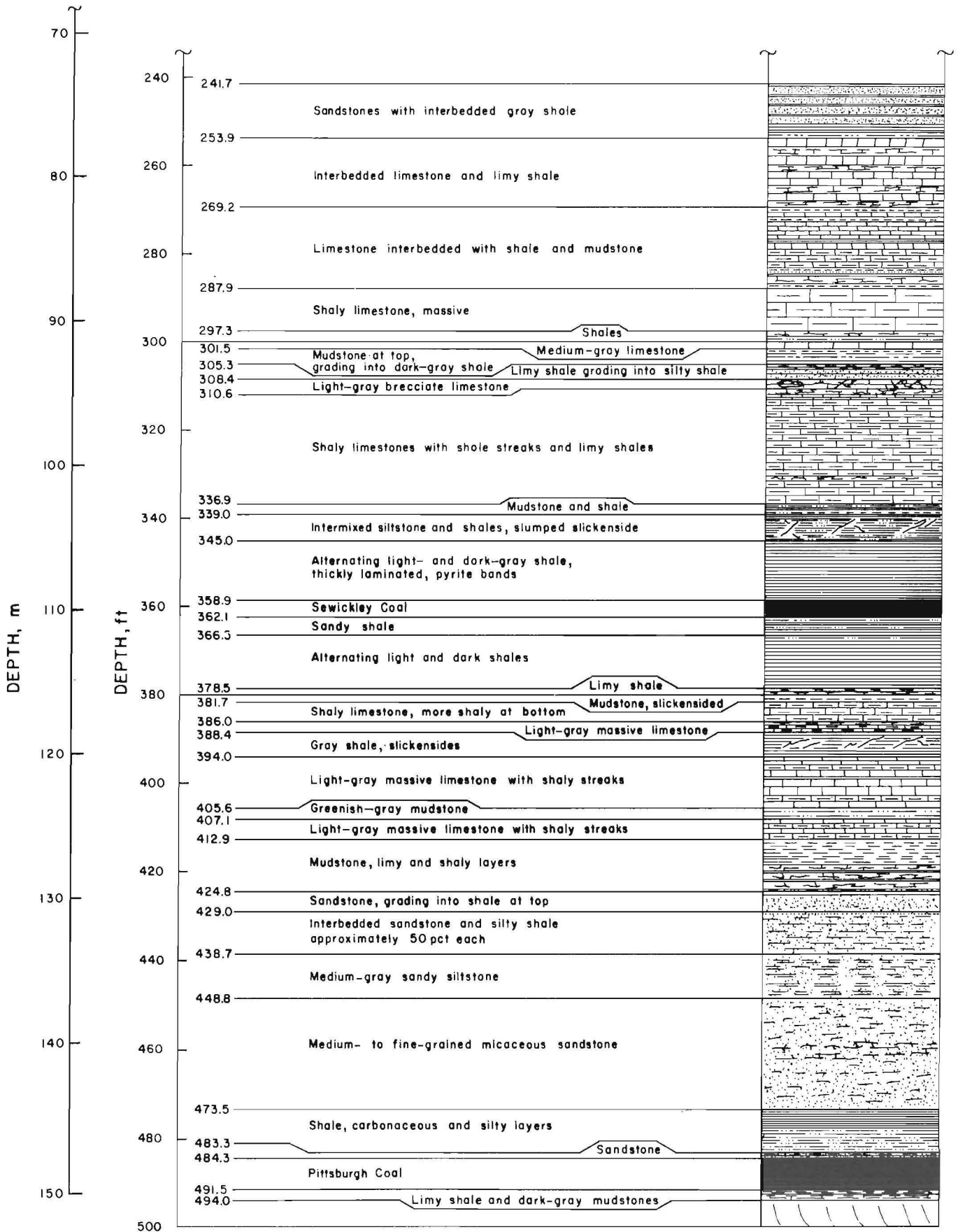

FIGURE 4. - Geologic column—Continued.

thick. These disks were ground and polished plane parallel to $\pm 500 \mu\text{in}$ ($12.7 \times 10^{-3} \text{ mm}$) in an Ingram Laboratories thin section grinder. The final surface polish was obtained using a 220-grit silicon carbide wheel. The geologic column is shown in figure 4. The depth below surface level is shown on the ordinate with the geologic material given on the abscissa.

Examples of the core derived from the original NX core and the finished disk

samples used for the measurements are shown in figure 5. The disks were stored in steel racks in desiccators except for the time taken during a measurement. The number of disks of each rock type at each depth ranged from 2 to 24 depending on the friability of the material.

The petrographic analysis of each rock type measured at a given depth is given in table A-1 (appendix A). Minerals and materials with a volume percent less than 5 are not included.

RESULTS

The experimental dielectric constant and dissipation factor values for the various rock types located at the defined depths are listed in table A-1. The mean value obtained from measurements of several disks and the standard deviation of the mean (SDM) are given. The values were determined at frequencies of 20, 40, 60, 80, and 100 MHz. The location down the drill core at which the rock samples were taken and measured is given, as well

as the rock type and major mineral components (in volume percent) for each depth and the percent of saturation for the rock samples measured.

The attenuation produced by a dielectric is expressed as the attenuation distance ($1/\alpha$) through which the field strength decays to $1/e = 0.368$ of its original value. The calculated values for attenuation distance (in meters) are

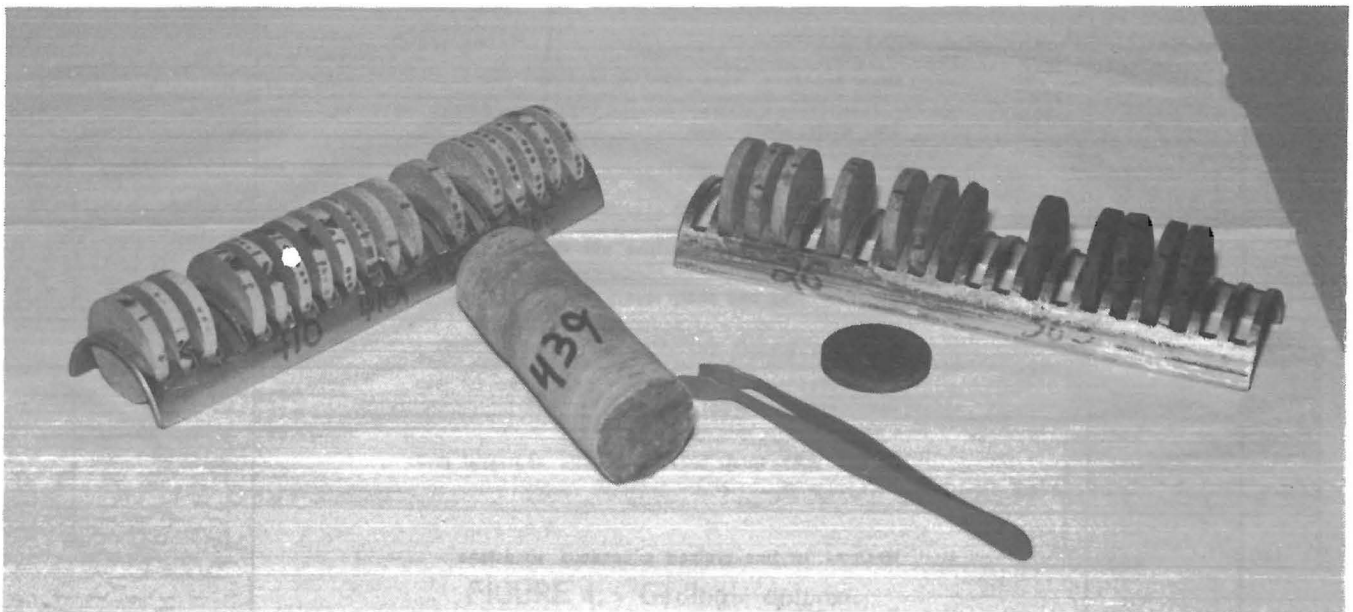

FIGURE 5. - Disk samples.

shown in table A-1. The equation used to calculate the attenuation distance from the measured values of dielectric constant and dissipation factor, as given by Von Hippel (9), is

$$\frac{1}{\alpha} = \frac{\lambda_0}{2\pi} \left[\frac{2}{K'(\sqrt{1+\tan^2\delta}-1)} \right]^{1/2}$$

where λ_0 = free space wavelength,

K' = dielectric constant,

$\tan \delta$ = dissipation factor,

and $\frac{1}{\alpha}$ = attenuation distance, m.

DISCUSSION

The dielectric constant and dissipation factor values are shown as a function of depth in figures 6 and 7, respectively, for the upper and lower values of frequency. The values for the dielectric constant range from a low of 4.3 to a high of 10.3. The low value was obtained for both 20 and 100 MHz in a micaceous sandstone located at a depth of 32.31 m. This rock had a moisture level of only 1 pct of saturation. It was composed of 50 to 75 pct quartz, 25 to 50 pct plagioclase, 5 to 10 pct mica, and 1 to 5 pct each of calcite, illite-kaolinite, and chlorite.

The highest value observed for the dielectric constant at a frequency of 20 MHz was 10.3 at a depth of 45.11 m in a shale containing 25 to 50 pct each of quartz and mica. It also contained 5 to 10 pct each of illite-kaolinite, plagioclase, and opaques. The opaques consisted of large clumps and veins of pyrite. The highest value obtained at 100 MHz was 8.2 for a limestone at 72.85 m containing over 75 pct calcite.

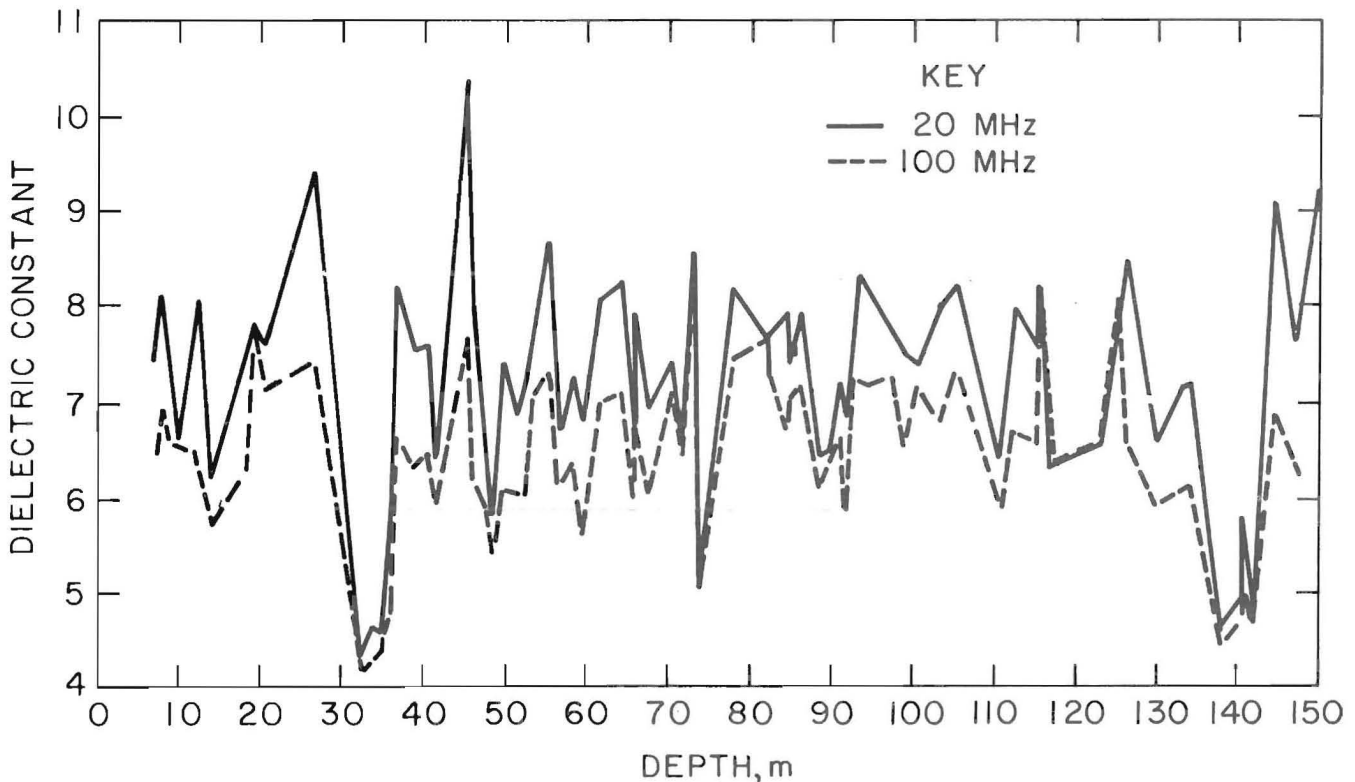

FIGURE 6. - Relative dielectric constant as a function of depth.

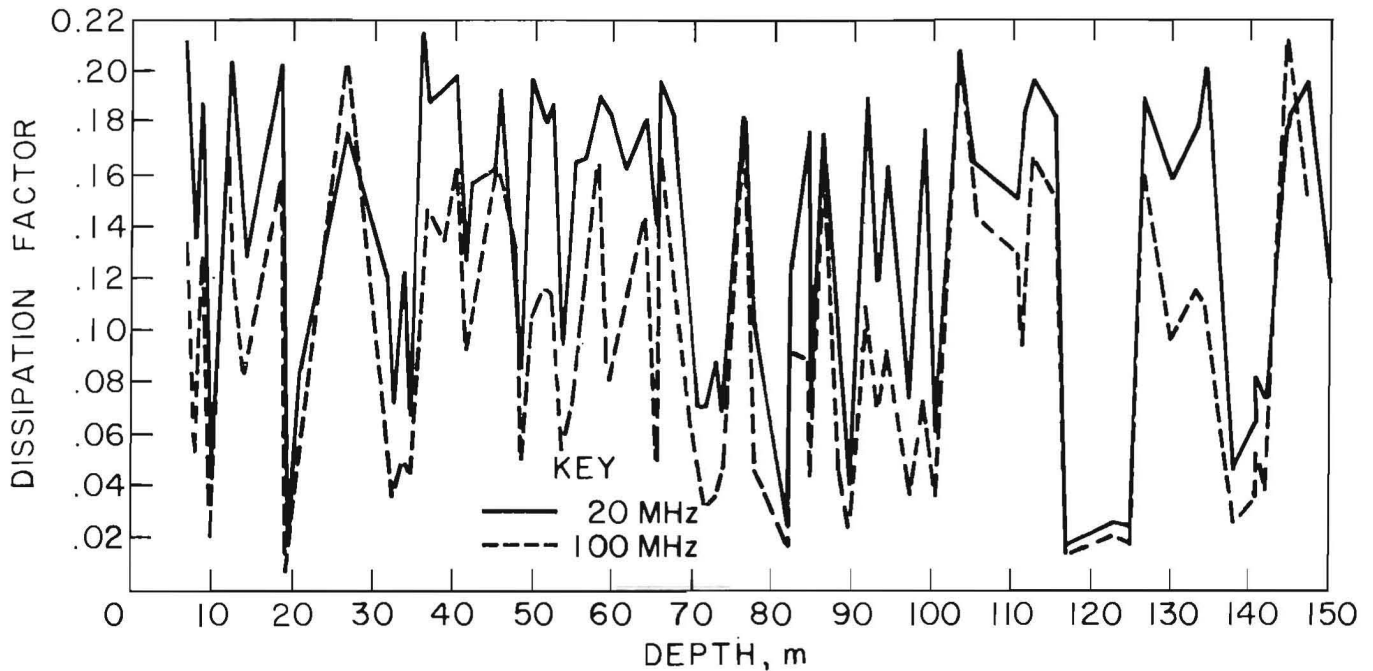

FIGURE 7. - Dissipation factor as a function of depth.

The lowest values observed for the dissipation factor, at both frequencies, were 0.008 and 0.007 from a limestone located at a depth of 19.20 m. This limestone contained greater than 75 pct calcite. At 20 MHz, a high dissipation factor value of 0.215 was observed in a sandstone located at a depth of 35.97 m. This sandstone contained 50 to 75 pct quartz, 10 to 25 pct plagioclase, 5 to 10 pct illite-kaolinite, and 5 to 10 pct mica. Only amounts of pyrite less than 1 pct were noted. The highest dissipation factor value observed at 100 MHz was 0.213 in a shale located at a depth of 144.5 m. This shale contained 25 to 50 pct each of mica and illite-kaolinite, 10 to 25 pct quartz, and 5 to 10 pct coal, which occurred in several zones. Only a trace of pyrite was observed. The moisture level was at 11 pct, which was one of the higher levels tested.

The computed attenuation distance ($1/\alpha$) is plotted as a function of depth and frequency and shown in figure 8. Maximum distances of 229.2 and 46.6 m, respectively, for 20 and 200 MHz, were observed at 19.2 m in the limestone containing

greater than 75 pct calcite. The moisture level was 3 pct of saturation, and the limestone contained minor constituents (less than 1 pct) of quartz, dolomite, illite-kaolinite, and coal.

The dielectric values of the minerals calcium carbonate (10), fused quartz (9), and mica (9) show that these minerals are very transparent in this frequency range. The impurities such as pyrite and water reduce the transparency.

The minimum attenuation distance of 1.7 m occurred at 100 MHz in two rock types. The first occurrence was at a depth of 26.52 m in a siltstone containing 50 to 75 pct calcite, 10 to 25 pct mica, 5 to 10 pct each of quartz and dolomite, and 1 to 5 pct each of illite-kaolinite and plagioclase. The second was at a depth of 144.5 m in a shale containing 25 to 50 pct each of mica and illite-kaolinite, 10 to 25 pct quartz, 5 to 10 pct coal, and 1 to 5 pct each of plagioclase and chlorite. The moisture level was high at 11 pct of saturation, and a trace of pyrite was observed.

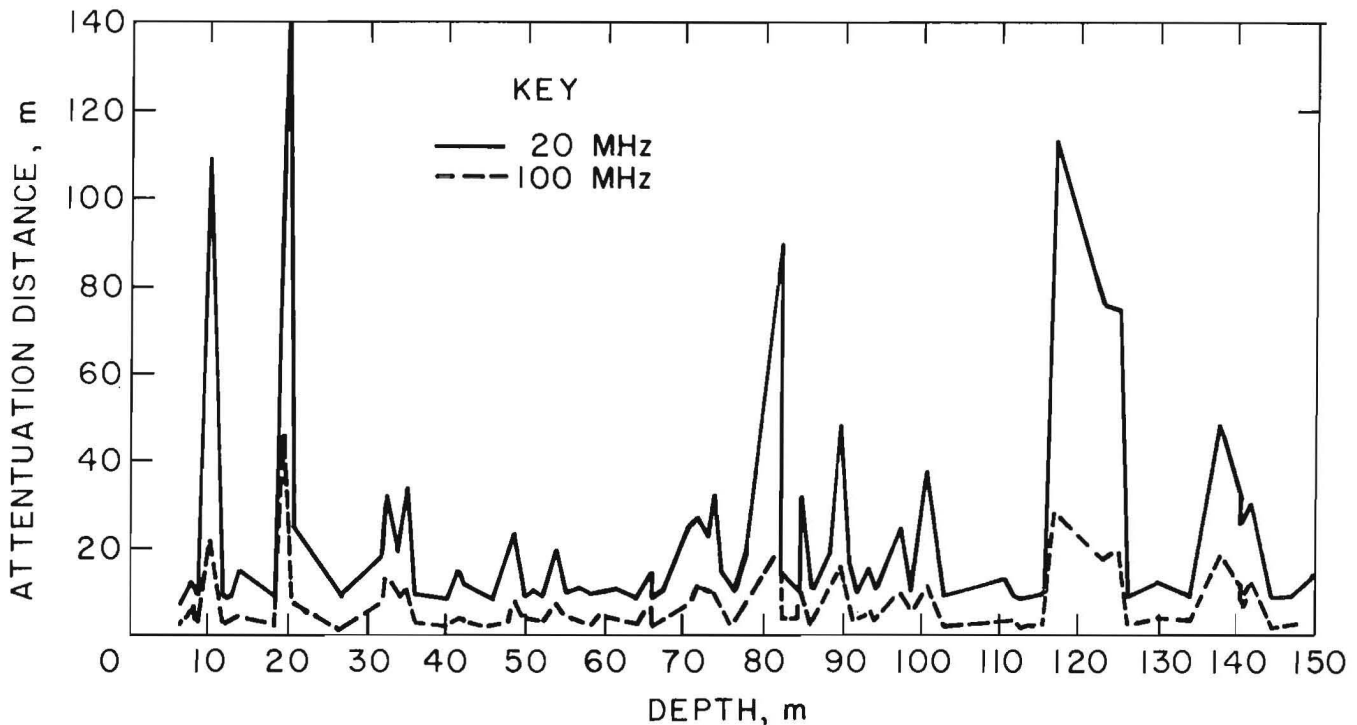

FIGURE 8. - Attenuation distance as a function of depth and frequency. The distance at a depth of 19.2 m and a frequency of 20 MHz is off the scale at 229.2 m.

Figure 9 summarizes the attenuation distance as a function of rock types. The values obtained for the attenuation distance (table A-1) were averaged for each rock type at frequencies of 20 and 100 MHz. For limestone the two values of 229.2 and 114.0 m were excluded as

extremes. Dolomite and limestone are shown to be the most transparent materials at these frequencies, owing to the high percentage content of the extremely transparent calcium carbonate (10). These values are in agreement with those given by Cook (2).

CONCLUSIONS

Electrical properties of Pittsburgh Seam coal measure rock were measured in a laboratory environment. Moisture contents were less than those in situ but were defined by measuring the percent of saturation. Several of the rocks had percent of saturation moisture levels exceeding the group mean of 6.41 pct, but this was expected in rock with differing physical properties such as porosity.

These controlled laboratory measurements help establish the maximum electromagnetic wave penetration distance for the frequency range of 20 to 100 MHz. The extreme values obtained for attenuation distance were a maximum of 229.2 m at 20 MHz, for a limestone at a depth of 19.2 m, and a minimum of 1.7 m at 100 MHz for a siltstone at 26.52 m and also for a shale at a depth of 144.5 m.

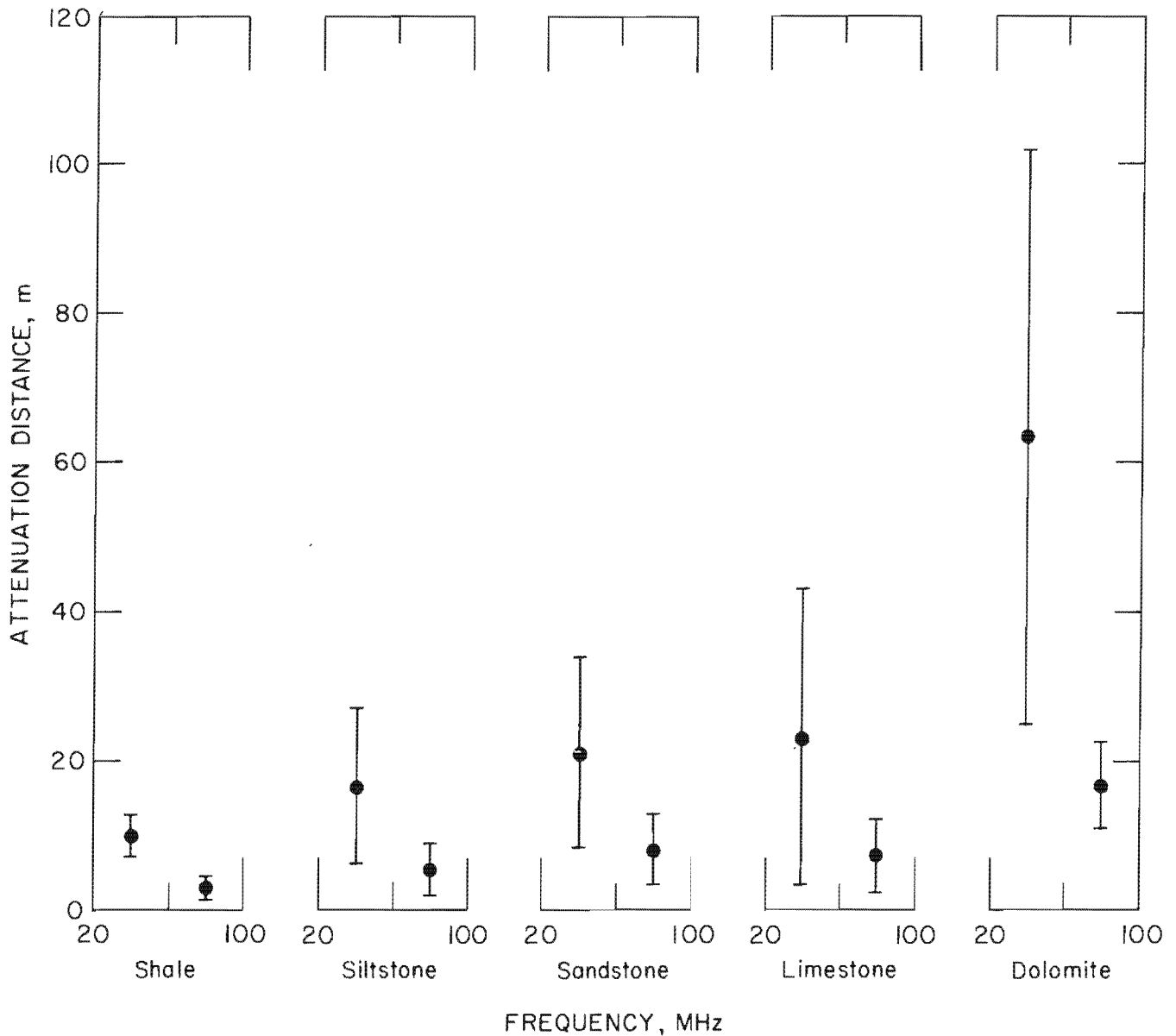

FIGURE 9. - Rock attenuation distance.

REFERENCES

1. U.S. Mine Safety and Health Administration (Dep. Labor). Mine Injuries and Worktime Q., Jan.-Dec. 1982.
2. Cook, J. C. Radar Transparencies of Mine and Tunnel Rocks. *Geophysics*, v. 40, No. 5, Oct. 1975, pp. 865-875.
3. Howell, B. F., Jr., and P. H. Licastro. Dielectric Behavior of Rocks and Minerals. *Am. Mineral.*, v. 46, Mar.-Apr. 1961, pp. 269-288.
4. Arsh, E. I., L. A. Krasin, and G. R. Nosov. Frequency Characteristics of the Electrical Properties of Coals and Country Rocks in the Western Donbass. *Sov. Min. Sci. (Eng. Transl.)*, No. 1, Jan.-Feb. 1969, pp. 65-68.
5. Geyer, R. G., and G. V. Keller. Constraints Affecting Through-The-Earth Electromagnetic Signalling and Location Techniques. *Radio Sci.*, v. 11, No. 4, Apr. 1976, pp. 323-342.

6. Griffin, R. E. Dielectric Constants and Dissipation Factors of Simulated Lunar Rocks. BuMines RI 7915, 1974, 19 pp.

7. Griffin, R. E., and R. L. Marovelli. Dielectric Constants and Dissipation Factors for Six Rock Types Between 20 and 100 Megahertz. BuMines RI 6913, 1967, 21 pp.

8. Moebs, N. N. Roof Rock Structures and Related Roof Support Problems in the

Pittsburgh Coalbed of Southwestern Pennsylvania. BuMines RI 8230, 1977, 30 pp.

9. Von Hippel, A. R. Dielectrics and Waves. Wiley, 1962, pp. 28-30.

10. Iglesias, J., and W. B. Westphal. Supplementary Dielectric Constant and Loss Measurements on High-Temperature Materials. Mass. Inst. Technol., Lab. for Insulation Res., Tech. Rep. 203, Jan. 1967, pp. 41, 80.

APPENDIX A.--EXPERIMENTAL DATA

The data obtained from the experimental measurements on the rock disks using the Q-meter are presented in table A-1. Both the mean value obtained from measurements of several disks and the standard deviation (SDM) are given for the experimental dielectric constant and dissipation factor values. The first column, marked "Depth," defines the location down the drill core (surface = 0) at which the rock samples were taken and measured.

For a given value of depth, the rock type and major mineral components are given in the right-hand portion of the table. The column marked "Moisture" gives values of percent of saturation for the rock samples measured. The calculated values for attenuation distance are shown in column 8. The symbols used for the minerals and rock types are defined in the table footnotes.

TABLE A-1. - Experimental data

DEPTH (M)	MOIST. (PCT SAT)	FREQ. (MHZ)	DIELEC. CONST.		DISSIP. FACTOR		ATTEN. DIST. (M)		ROCK TYPE	MINERALS (VOL PCT)													
			MEAN	SDM	MEAN	SDM	MEAN	SDM		QU	CA	DO	MI	IL	PL	CH	CO	OP					
6.71	10.	20.	7.3	.5	.232	.051	8.1	2.0	SH	5				5	5			3					
		40.	6.7	.4	.169	.016	5.6	.7															
		60.	6.5	.3	.172	.027	3.8	.7															
		80.	6.4	.3	.145	.012	3.3	.4															
		100.	6.2	.3	.134	.015	2.9	.4															
7.32	7.	20.	7.8	.3	.159	.010	11.0	.8	SH	4	4			3	4			3	4				
		40.	7.3	.3	.140	.014	6.5	.6															
		60.	7.1	.2	.138	.011	4.4	.4															
		80.	6.9	.2	.130	.011	3.6	.3															
		100.	6.7	.1	.117	.012	3.3	.3															
7.92	9.	20.	8.1	.1	.135	.004	12.5	.4	SH		7												
		40.	7.7	.0	.108	.003	8.1	.2															
		60.	7.4	.0	.081	.002	7.3	.2															
		80.	7.1	.1	.066	.003	6.9	.3															
		100.	7.0	.1	.050	.002	7.4	.3															
8.53	10.	20.	7.7	.1	.188	.004	9.2	.2	SH	4	5	4	3		3								
		40.	7.0	.1	.153	.004	5.9	.1															
		60.	6.9	.1	.151	.003	4.0	.1															
		80.	6.7	.1	.131	.003	3.5	.1															
		100.	6.6	.1	.130	.003	2.9	.1															
10.06	6.	20.	6.6	.1	.019	.002	109.2	12.4	DO		4	6											
		40.	6.6	.1	.017	.002	57.0	4.5															
		60.	6.6	.1	.019	.002	35.7	3.1															
		80.	6.5	.1	.017	.002	30.1	2.8															
		100.	6.6	.1	.017	.002	23.1	2.0															
11.89	6.	20.	7.8	.2	.203	.002	8.5	.0	SH	4	3			5	5	4							
		40.	7.0	.1	.215	.005	4.2	.1															
		60.	6.8	.1	.192	.005	3.2	.1															
		80.	6.7	.1	.183	.004	2.5	.1															
		100.	6.5	.1	.172	.015	2.2	.2															
12.50	6.	20.	8.1	.2	.197	.003	8.6	.1	SH	4				5	5	4							
		40.	7.2	.1	.183	.009	5.0	.3															
		60.	6.5	.1	.153	.011	4.2	.3															
		80.	6.4	.1	.137	.008	3.5	.2															
		100.	6.2	.1	.118	.007	3.3	.2															
14.02	5.	20.	6.2	.2	.126	.004	15.4	.7	SH	4	5			5	4	4							
		40.	5.9	.2	.110	.003	9.0	.4															
		60.	5.8	.2	.095	.002	7.0	.3															
		80.	5.7	.2	.090	.003	5.6	.2															
		100.	5.7	.2	.083	.002	4.9	.2															
18.29	6.	20.	7.5	.1	.202	.003	8.7	.1	SH	5	3			5	4	4	3						
		40.	7.0	.0	.207	.001	4.4	.0															
		60.	6.4	.0	.152	.002	4.1	.1															
		80.	6.4	.0	.150	.002	3.2	.0															
		100.	6.3	.0	.159	.002	2.4	.0															

See notes at end of table.

TABLE A-1. - Experimental data--Continued

18

DEPTH (M)	MOIST. (PCT SAT)	FREQ. (MHZ)	DIELEC. CONST.		DISSIP. FACTOR		ATTEN. DIST. (M)		ROCK TYPE	MINERALS (VOL PCT)										
			MEAN	SDM	MEAN	SDM	MEAN	SDM		QU	CA	DO	MI	IL	PL	CH	CO	OP		
19.20	3.	20.	7.8	.0	.008	.000	229.2	8.7	LI	7										
		40.	7.8	.0	.007	.000	130.1	7.2												
		60.	7.8	.0	.006	.000	91.5	5.9												
		80.	7.9	.0	.006	.000	69.5	3.7												
		100.	7.8	.0	.007	.000	46.6	2.7												
20.42	2.	20.	7.6	.1	.081	.010	25.1	5.0	LI	3	7									
		40.	7.3	.1	.062	.008	16.1	2.8												
		60.	7.3	.2	.060	.006	10.9	1.7												
		80.	7.2	.2	.055	.006	8.9	1.4												
		100.	7.1	.1	.052	.005	7.5	1.1												
26.52	3.	20.	9.5	.1	.176	.002	8.9	.0	SI	3	6	3	4							
		40.	8.4	.1	.207	.001	4.0	.0												
		60.	8.0	.0	.206	.003	2.8	.0												
		80.	7.6	.1	.208	.005	2.1	.1												
		100.	7.4	.0	.204	.005	1.7	.0												
31.70	3.	20.	5.0	.0	.118	.004	18.3	.7	SA	6				3			5			
		40.	4.9	.0	.099	.003	11.0	.3												
		60.	4.8	.0	.076	.002	9.7	.3												
		80.	4.7	.0	.056	.002	10.1	.3												
		100.	4.7	.0	.058	.001	7.6	.2												
32.31	1.	20.	4.3	.0	.072	.003	32.4	1.5	SA	6				3			5			
		40.	4.3	.0	.049	.001	23.7	.6												
		60.	4.2	.0	.028	.001	28.5	1.3												
		80.	4.3	.0	.045	.001	12.9	.4												
		100.	4.3	.0	.033	.002	14.3	.7												
33.83	3.	20.	4.7	.0	.123	.006	18.5	.9	SA	5				3			5			
		40.	4.4	.0	.053	.002	22.0	.9												
		60.	4.3	.0	.057	.001	13.4	.3												
		80.	4.3	.0	.047	.003	12.6	.6												
		100.	4.3	.0	.050	.003	9.5	.5												
34.75	2.	20.	4.6	.0	.066	.002	34.0	1.1	SA	6				4	4		5			
		40.	4.5	.0	.058	.001	19.5	.5												
		60.	4.5	.0	.053	.001	14.3	.4												
		80.	4.4	.0	.045	.001	12.6	.4												
		100.	4.4	.0	.044	.002	10.5	.5												
35.97	4.	20.	5.4	.0	.215	.004	9.6	.2	SA	6				3	3		4			
		40.	5.2	.0	.191	.003	5.5	.1												
		60.	5.0	.0	.163	.003	4.4	.1												
		80.	4.8	.0	.146	.004	3.8	.1												
		100.	4.7	.0	.117	.002	3.8	.1												
36.58	13.	20.	8.3	.2	.187	.002	8.9	.0	SH	4				4	6	3	3			
		40.	7.5	.1	.196	.012	4.5	.3												
		60.	7.1	.0	.182	.010	3.3	.2												
		80.	6.8	.1	.170	.000	2.7	.0												
		100.	6.7	.0	.148	.005	2.5	.1												

See notes at end of table.

TABLE A-1. - Experimental data--Continued

DEPTH (M)	MOIST. (PCT SAT)	FREQ. (MHZ)	DIELEC. CONST.		DISSIP. FACTOR		ATTEN. DIST. (M)		ROCK TYPE	QU	MINERALS (VOL PCT)								
			MEAN	SDM	MEAN	SDM	MEAN	SDM			CA	DO	MI	IL	PL	CH	CO	DP	
38.71	9.	20.	7.5	.1	.193	.002	9.1	.1	SH	5			5	3	3				
		40.	6.9	.0	.166	.003	5.5	.1											
		60.	6.5	.0	.141	.003	4.5	.1											
		80.	6.5	.0	.142	.002	3.3	.0											
		100.	6.3	.0	.132	.004	2.9	.1											
40.23	12.	20.	7.6	.1	.199	.003	8.8	.2	SH	5	3		5	3	3				
		40.	7.0	.1	.185	.006	4.9	.2											
		60.	6.6	.1	.164	.005	3.8	.1											
		80.	6.4	.1	.149	.005	3.2	.1											
		100.	6.5	.1	.164	.005	2.3	.1											
41.45	11.	20.	6.4	.1	.125	.004	15.3	.6	SH	6			4	3	4				
		40.	6.2	.1	.113	.004	8.6	.3											
		60.	6.0	.1	.102	.004	6.4	.3											
		80.	5.9	.1	.097	.003	5.1	.2											
		100.	5.9	.1	.091	.003	4.4	.2											
42.06	7.	20.	6.8	.0	.157	.003	11.8	.2	SI	5			4		3	3			
		40.	6.6	.1	.139	.005	6.8	.3											
		60.	6.3	.1	.122	.002	5.2	.1											
		80.	6.3	.1	.122	.002	3.9	.1											
		100.	6.1	.1	.098	.002	4.0	.1											
45.11	5.	20.	10.3	.3	.162	.005	9.2	.2	SH/CO	5			5	3	3			3	
		40.	8.9	.2	.182	.019	4.5	.4											
		60.	8.4	.4	.201	.010	2.7	.1											
		80.	7.9	.3	.210	.009	2.0	.0											
		100.	7.7	.4	.162	.006	2.1	.0											
45.72	7.	20.	8.5	.3	.193	.004	8.5	.1	SH	5			5	4	3				
		40.	7.4	.2	.203	.004	4.4	.1											
		60.	6.7	.2	.189	.011	3.4	.2											
		80.	6.5	.2	.175	.012	2.8	.2											
		100.	6.3	.1	.163	.011	2.4	.2											
47.85	15.	40.	6.4	.1	.210	.007	4.6	.2	SA	5	5				4				
		60.	6.1	.0	.169	.006	3.9	.1											
		80.	6.0	.0	.150	.005	3.3	.1											
		100.	5.9	.1	.130	.005	3.1	.1											
		20.	5.8	.1	.088	.007	23.8	1.9											
40.	5.6	.1	.075	.005	14.0	1.0													
60.	5.5	.1	.066	.005	10.8	.8													
80.	5.4	.1	.056	.004	9.6	.7													
100.	5.4	.1	.050	.004	8.7	.6													
49.68	9.	20.	7.5	.1	.198	.005	8.9	.3	SH	5			5	3	4	3			
		40.	6.8	.1	.177	.006	5.2	.2											
		60.	6.6	.1	.157	.003	4.0	.1											
		80.	6.3	.1	.140	.002	3.4	.1											
		100.	6.1	.1	.105	.001	3.7	.0											

See notes at end of table.

TABLE A-1. - Experimental data--Continued

DEPTH (M)	MOIST. (PCT SAT)	FREQ. (MHZ)	DIELEC. CONST.		DISSIP. FACTOR		ATTEN. DIST. (M)		ROCK TYPE	QU	MINERALS (VOL PCT)					CH	CO	OP	
			MEAN	SDM	MEAN	SDM	MEAN	SDM			CA	DO	MI	IL	PL				
51.21	10.	20.	6.9	.0	.178	.003	10.3	.2	SH	5			4	4	4	3			
		40.	6.6	.1	.165	.002	5.7	.1											
		60.	6.4	.0	.150	.002	4.2	.1											
		80.	6.1	.0	.127	.002	3.8	.1											
52.12	10.	100.	6.1	.0	.116	.002	3.3	.1	SH	5			3	3	4				
		20.	7.1	.1	.189	.002	9.5	.2											
		40.	6.4	.1	.147	.003	6.4	.2											
		60.	6.4	.1	.145	.003	4.4	.1											
53.64	6.	80.	6.1	.1	.124	.003	3.9	.1	LI/DO	3	6	5							
		100.	6.0	.1	.114	.002	3.4	.1											
		20.	7.8	.5	.094	.025	19.8	5.8											
		40.	7.5	.4	.078	.021	12.3	3.7											
55.17	7.	60.	7.3	.3	.067	.018	9.4	2.7	LI	3	6	4	3						
		80.	7.2	.3	.059	.019	8.4	2.8											
		100.	7.2	.3	.051	.013	7.5	2.1											
		20.	8.7	.0	.165	.003	9.9	.2											
56.69	13.	40.	8.0	.0	.144	.002	5.9	.1	SA	5	4		4	4	4	4			
		60.	7.6	.0	.114	.001	5.1	.1											
		80.	7.4	.0	.096	.001	4.5	.1											
		100.	7.3	.0	.081	.001	4.4	.0											
58.22	13.	20.	6.7	.0	.166	.003	11.2	.2	SH/SA	5	4		4	3	5				
		40.	6.4	.0	.154	.004	6.2	.2											
		60.	6.2	.0	.148	.005	4.4	.2											
		80.	6.2	.0	.152	.002	3.2	.1											
59.44	9.	100.	6.1	.0	.138	.005	2.8	.1	SA	5			3		5	3			
		20.	7.3	.1	.191	.003	9.3	.1											
		40.	6.9	.0	.188	.003	4.9	.1											
		60.	6.5	.0	.167	.002	3.8	.1											
61.57	3.	80.	6.5	.0	.167	.002	2.8	.0	LI	5	7								
		100.	6.4	.0	.167	.004	2.3	.1											
		20.	6.8	.1	.183	.003	10.2	.3											
		40.	6.2	.1	.145	.004	6.8	.3											
64.01	12.	60.	5.9	.1	.118	.003	5.6	.2	LI	3	6								
		80.	5.7	.1	.097	.003	5.2	.2											
		100.	5.6	.1	.079	.002	5.2	.2											
		20.	8.1	.1	.162	.012	10.6	.7											
		40.	7.6	.1	.125	.010	7.1	.5											
		60.	7.3	.1	.125	.014	4.9	.4											
		80.	7.1	.1	.116	.015	4.1	.4											
		100.	7.0	.1	.108	.015	3.6	.4											
		20.	8.3	.1	.182	.003	9.2	.1	LI	3	6								
		40.	7.8	.1	.170	.005	5.1	.1											
		60.	7.5	.1	.157	.003	3.7	.1											
		80.	7.2	.1	.152	.004	2.9	.1											
		100.	7.1	.1	.146	.004	2.5	.1											

See notes at end of table.

TABLE A-1. - Experimental data--Continued

DEPTH (M)	MOIST. (PCT SAT)	FREQ. (MHZ)	DIELEC. CONST.		DISSIP. FACTOR		ATTEN. DIST. (M)		ROCK TYPE	QU	MINERALS (VOL PCT)					CH	CO	OP	
			MEAN	SDM	MEAN	SDM	MEAN	SDM			CA	DO	MI	IL	PL				
65.84	1.	20.	6.7	.0	.129	.006	14.8	1.0	SH	5			5	3	3				
		40.	6.4	.0	.100	.005	9.8	.7											
		60.	6.3	.0	.078	.004	8.5	.6											
		80.	6.3	.0	.083	.005	6.1	.6											
		100.	6.0	.1	.048	.002	8.3	.5											
65.84	5.	20.	7.9	.1	.197	.006	8.7	.2	SH	5			5	3	3				
		40.	7.3	.1	.204	.015	4.5	.4											
		60.	7.1	.1	.198	.014	3.1	.2											
		80.	6.9	.1	.187	.013	2.5	.2											
		100.	6.7	.1	.176	.012	2.2	.1											
67.36	8.	20.	6.9	.1	.182	.002	10.0	.2	SH	5			4	3	4				
		40.	6.6	.1	.163	.001	5.7	.1											
		60.	6.5	.0	.159	.002	4.0	.1											
		80.	6.4	.0	.155	.002	3.1	.0											
		100.	6.0	.0	.120	.003	3.3	.1											
70.41	7.	20.	7.4	.0	.071	.003	25.0	1.0	LI		5	6							
		40.	7.3	.0	.062	.003	14.4	.6											
		60.	7.3	.0	.057	.002	10.4	.3											
		80.	7.2	.0	.055	.002	8.3	.3											
		100.	7.2	.0	.051	.002	7.1	.2											
71.63	2.	20.	6.7	.0	.070	.003	26.9	1.5	LI			6							
		40.	6.6	.0	.053	.002	18.0	.8											
		60.	6.5	.0	.044	.001	14.1	.2											
		80.	6.4	.0	.041	.002	11.8	.5											
		100.	6.4	.0	.033	.001	11.5	.5											
72.85	9.	20.	8.6	.1	.089	.009	22.0	2.4	LI		7								
		40.	8.4	.1	.068	.007	14.7	1.6											
		60.	8.3	.1	.058	.005	10.8	1.0											
		80.	8.3	.0	.050	.005	9.5	.8											
		100.	8.2	.0	.035	.002	10.0	.7											
73.76	2.	20.	5.2	.1	.067	.003	31.9	1.7	SI	6	4				5				
		40.	5.1	.1	.055	.002	19.5	.8											
		60.	5.0	.1	.049	.002	14.5	.6											
		80.	5.1	.1	.050	.002	10.7	.4											
		100.	5.0	.1	.043	.002	10.2	.5											
74.68	4.	20.	6.0	.1	.143	.012	14.4	1.2	SI	6	4	3			4				
		40.	5.8	.1	.112	.009	9.3	.7											
		60.	5.6	.1	.097	.008	7.3	.6											
		80.	5.6	.1	.090	.007	5.9	.4											
		100.	5.5	.1	.078	.006	5.5	.4											
76.20	5.	20.	7.1	.1	.182	.004	10.0	.3	SH	5		4	4	4					
		40.	6.6	.1	.165	.005	5.7	.2											
		60.	6.9	.1	.204	.005	3.0	.1											
		80.	6.7	.1	.193	.006	2.4	.1											
		100.	6.4	.1	.178	.004	2.1	.1											

See notes at end of table.

TABLE A-1. - Experimental data--Continued

DEPTH (M)	MOIST. (PCT SAT)	FREQ. (MHZ)	DIELEC. CONST.		DISSIP. FACTOR		ATTEN. DIST. (M)		ROCK TYPE	MINERALS (VOL PCT)								
			MEAN	SDM	MEAN	SDM	MEAN	SDM		QU	CA	DO	MI	IL	PL	CH	CO	OP
77.72	9.	20.	8.2	.0	.105	.012	18.2	2.2	LI	7								
		40.	7.8	.1	.085	.010	11.4	1.3										
		60.	7.6	.1	.064	.007	10.1	1.1										
		80.	7.5	.1	.058	.006	8.4	.8										
		100.	7.5	.2	.048	.005	8.2	.9										
81.99	9.	20.	7.7	.0	.020	.002	89.8	9.2	LI	5 6								
		40.	7.6	.0	.016	.002	54.2	5.6										
		60.	7.7	.0	.014	.003	42.7	8.2										
		80.	7.6	.1	.016	.002	28.3	3.1										
		100.	7.7	.1	.017	.002	21.1	2.3										
81.99	9.	20.	7.3	.1	.072	.000	24.5	.1	LI	5 6								
		40.	7.3	.0	.064	.001	13.8	.2										
		60.	7.2	.0	.062	.002	9.6	.3										
		80.	7.1	.1	.061	.000	7.3	.0										
		100.	7.1	.1	.059	.001	6.0	.1										
81.99	9.	20.	7.7	.1	.118	.002	14.6	.3	LI	5 6								
		40.	7.5	.0	.105	.003	8.3	.3										
		60.	7.4	.0	.097	.003	6.1	.2										
		80.	7.3	.0	.099	.002	4.5	.1										
		100.	7.4	.0	.093	.002	3.8	.1										
84.43	8.	20.	7.9	.1	.178	.007	9.7	.4	LI	3 5 5 3								
		40.	7.1	.1	.138	.006	6.6	.3										
		60.	7.1	.1	.136	.006	4.5	.2										
		80.	6.9	.1	.111	.004	4.1	.2										
		100.	6.7	.1	.089	.004	4.2	.2										
84.73	2.	20.	7.4	.0	.070	.010	31.9	5.6	LI	6 5								
		40.	7.2	.1	.057	.009	19.9	3.5										
		60.	7.1	.1	.050	.007	15.1	2.5										
		80.	7.1	.1	.045	.007	12.6	2.0										
		100.	7.1	.1	.041	.006	10.6	1.6										
85.95	11.	20.	7.9	.1	.177	.007	9.7	.3	LI	3 6 5 3 3 3								
		40.	7.3	.1	.154	.011	5.8	.3										
		60.	7.7	.1	.188	.008	3.1	.1										
		80.	8.0	.4	.166	.004	2.6	.1										
		100.	7.2	.1	.166	.010	2.2	.1										
88.39	2.	20.	6.4	.0	.099	.003	19.2	.6	DO	7								
		40.	6.2	.0	.062	.002	15.7	.6										
		60.	6.2	.0	.061	.002	10.6	.5										
		80.	6.1	.0	.052	.001	9.3	.3										
		100.	6.1	.0	.043	.001	9.1	.2										
89.61	1.	20.	6.5	.1	.040	.002	48.9	2.8	DO	3 7								
		40.	6.4	.1	.031	.002	31.6	1.5										
		60.	6.4	.1	.028	.001	22.8	1.1										
		80.	6.4	.1	.025	.001	19.6	.9										
		100.	6.4	.1	.023	.001	16.8	.8										

See notes at end of table.

TABLE A-1. - Experimental data--Continued

DEPTH (M)	MOIST. (PCT SAT)	FREQ. (MHZ)	DIELEC. CONST.		DISSIP. FACTOR		ATTEN. DIST. (M)		ROCK TYPE	MINERALS (VOL PCT)								
			MEAN	SDM	MEAN	SDM	MEAN	SDM		QU	CA	OO	MI	IL	PL	CH	CO	OP
90.83	4.	20.	7.2	.1	.102	.002	17.5	.3	LI	4	6	5	3					3
		40.	7.0	.1	.086	.002	10.6	.2										
		60.	6.8	.1	.077	.002	7.9	.2										
		80.	6.7	.1	.069	.001	6.7	.1										
		100.	6.7	.1	.062	.002	5.9	.2										
91.74	4.	20.	6.9	.1	.191	.003	9.6	.2	SH	3			6	5	4	4		
		40.	6.4	.1	.174	.003	5.5	.1										
		60.	5.7	.1	.125	.005	5.4	.2										
		80.	5.8	.1	.124	.005	4.0	.2										
		100.	5.7	.1	.111	.005	3.6	.2										
92.66	10.	20.	8.0	.1	.126	.002	13.5	.2	LI		6	5						
		40.	7.4	.1	.086	.001	10.2	.1										
		60.	7.5	.0	.097	.002	6.0	.1										
		80.	7.4	.0	.090	.002	4.9	.1										
		100.	7.3	.1	.085	.002	4.2	.1										
93.27	8.	20.	8.4	.3	.116	.012	15.2	1.7	LI		7	4						
		40.	7.8	.1	.116	.011	7.8	.8										
		60.	7.1	.1	.059	.006	10.7	.9										
		80.	7.3	.1	.064	.006	7.3	.7										
		100.	7.2	.1	.068	.006	5.4	.4										
94.18	5.	20.	8.2	.1	.164	.007	10.3	.5	LI		5	6						
		40.	7.7	.0	.141	.008	6.2	.3										
		60.	7.4	.1	.120	.005	4.9	.2										
		80.	7.2	.1	.110	.006	4.1	.2										
		100.	7.2	.0	.094	.005	3.8	.2										
97.23	2.	20.	7.8	.0	.072	.003	24.4	1.0	LI		6	5						
		40.	7.5	.1	.048	.005	21.6	2.5										
		60.	7.3	.0	.036	.002	16.8	.7										
		80.	7.3	.0	.040	.002	11.5	.5										
		100.	7.3	.1	.035	.001	10.3	.3										
98.76	1.	20.	7.5	.1	.177	.004	9.9	.2	LI	3	5	5						3
		40.	7.1	.1	.135	.006	6.9	.3										
		60.	6.8	.1	.120	.007	5.4	.3										
		80.	6.7	.1	.121	.006	4.0	.2										
		100.	6.5	.1	.074	.003	5.3	.2										
100.6	3.	20.	7.4	.0	.053	.006	37.5	3.9	LI		5	6						
		40.	7.3	.0	.042	.005	23.9	2.6										
		60.	7.3	.0	.043	.005	15.4	1.6										
		80.	7.2	.0	.037	.004	13.4	1.4										
		100.	7.2	.0	.034	.004	11.9	1.2										
103.0	4.	20.	8.0	.3	.199	.005	8.5	.1	SH	5			5	4	4			
		40.	7.2	.2	.224	.003	4.0	.1										
		60.	6.7	.2	.179	.004	3.5	.1										
		80.	7.1	.2	.208	.005	2.2	.0										
		100.	6.8	.0	.210	.025	1.8	.2										

See notes at end of table.

TABLE A-1. - Experimental data--Continued

DEPTH (M)	MOIST. (PCT SAT)	FREQ. (MHZ)	DIELEC. CONST.		DISSIP. FACTOR		ATTEN. DIST. (M)		ROCK TYPE	QU	MINERALS (VOL PCT)					CH	CO	OP
			MEAN	SDM	MEAN	SDM	MEAN	SDM			CA	DO	MI	IL	PL			
105.2	6.	20.	8.2	.1	.165	.004	10.2	.3	SH	5		4	3	4			4	
		40.	7.9	.1	.174	.007	4.9	.2										
		60.	7.8	.1	.175	.005	3.3	.1										
		80.	7.3	.1	.137	.004	3.3	.1										
110.6	8.	100.	7.4	.1	.144	.006	2.5	.1	SH	5		5	5	4				
		20.	6.4	.0	.150	.003	12.7	.3										
		40.	6.1	.0	.136	.003	7.2	.2										
		60.	6.0	.0	.124	.003	5.2	.1										
111.3	5.	80.	6.1	.0	.136	.005	3.6	.2	SH	5		5	4	4		3	3	
		100.	6.0	.0	.130	.005	3.0	.1										
		20.	7.1	.1	.182	.005	10.0	.4										
		40.	6.4	.1	.143	.005	6.7	.3										
112.5	7.	60.	6.2	.1	.133	.005	4.9	.2	SH	4								
		80.	6.1	.1	.121	.004	4.0	.2										
		100.	6.0	.1	.094	.004	4.2	.2										
		20.	8.0	.1	.197	.002	8.6	.0										
115.2	5.	40.	7.4	.1	.198	.003	4.5	.1	SH	5		3	3	3		4		
		60.	6.6	.0	.150	.005	4.2	.1										
		80.	6.6	.0	.148	.005	3.2	.1										
		100.	6.6	.0	.151	.009	2.5	.1										
115.5	9.	20.	8.2	.3	.173	.010	9.7	.7	LI	3	6						4	
		40.	7.4	.2	.109	.021	8.7	1.5										
		60.	7.4	.2	.131	.010	4.6	.4										
		80.	7.6	.1	.140	.010	3.1	.3										
116.7	6.	100.	7.6	.1	.151	.008	2.3	.1	LI		4	6						
		20.	6.3	.0	.017	.000	114.0	1.7										
		40.	6.3	.0	.016	.000	60.8	.8										
		60.	6.3	.0	.014	.000	47.0	.9										
122.8	2.	80.	6.3	.0	.013	.000	37.3	1.1	DO		3	7						
		100.	6.3	.0	.013	.000	28.6	.5										
		20.	6.6	.0	.026	.002	76.6	6.6										
		40.	6.5	.1	.023	.002	41.9	3.2										
125.0	15.	60.	6.5	.1	.021	.001	30.6	1.8	LI	5	6							
		80.	6.5	.0	.020	.001	23.4	1.2										
		100.	6.6	.1	.021	.001	18.1	1.1										
		20.	8.0	.1	.024	.002	74.5	5.9										
		40.	7.9	.1	.021	.002	42.2	3.0										
		60.	7.9	.1	.020	.002	30.1	2.3										
		80.	7.9	.1	.019	.001	23.0	1.1										
		100.	7.9	.1	.018	.001	19.6	.9										

See notes at end of table.

TABLE A-1. - Experimental data--Continued

DEPTH (M)	MOIST. (PCT SAT)	FREQ. (MHZ)	DIELEC. CONST.		DISSIP. FACTOR		ATTEN. DIST. (M)		ROCK TYPE	QU	MINERALS (VOL PCT)							
			MEAN	SDM	MEAN	SDM	MEAN	SDM			CA	DO	MI	IL	PL	CH	CO	OP
			126.2	3.	20.	8.5	.2	.191			.004	8.6	.1	SH	3			
		40.	7.4	.1	.220	.004	4.0	.1										
		60.	7.1	.1	.198	.004	3.0	.1										
		80.	6.8	.1	.183	.006	2.5	.1										
		100.	6.6	.1	.161	.008	2.3	.1										
129.8	5.	20.	6.6	.1	.158	.009	12.3	1.0	SH	6			4	4	4	4		
		40.	6.2	.1	.126	.007	7.8	.5										
		60.	6.0	.1	.112	.007	6.0	.5										
		80.	5.9	.1	.109	.007	4.7	.4										
		100.	5.9	.1	.097	.005	4.1	.2										
132.9	11.	20.	7.2	.2	.179	.005	10.1	.4	SA	6			4	4	3	3		
		40.	6.7	.1	.164	.006	5.7	.3										
		60.	6.5	.2	.151	.006	4.2	.2										
		80.	6.2	.1	.125	.006	3.9	.2										
		100.	6.1	.1	.117	.006	3.4	.2										
134.1	8.	20.	7.2	.1	.202	.004	8.9	.1	SA	4			5	5	3	3		
		40.	6.8	.1	.176	.004	5.2	.1										
		60.	6.4	.1	.149	.004	4.2	.1										
		80.	6.2	.1	.124	.004	3.9	.1										
		100.	6.1	.1	.110	.003	3.5	.1										
137.8	3.	20.	4.6	.0	.046	.001	48.9	1.5	SA	5	3		4	4	5			
		40.	4.5	.0	.030	.001	37.3	1.3										
		60.	4.5	.0	.025	.001	30.9	1.3										
		80.	4.5	.0	.026	.001	21.8	.8										
		100.	4.4	.0	.024	.001	19.0	.7										
140.5	2.	20.	5.0	.0	.066	.002	32.6	1.0	SA	6	3		4	4	3			
		40.	4.9	.0	.058	.001	18.6	.4										
		60.	4.8	.0	.052	.002	14.1	.5										
		80.	4.8	.0	.043	.001	12.6	.4										
		100.	4.8	.0	.037	.001	11.8	.2										
140.5	2.	20.	5.8	.2	.083	.009	25.1	2.6	SA	6	3		4	4	3			
		40.	5.6	.2	.071	.008	14.9	1.5										
		60.	5.4	.2	.069	.009	10.6	1.3										
		80.	5.3	.2	.062	.008	9.0	1.1										
		100.	5.1	.2	.054	.007	8.3	1.0										
141.7	3.	20.	4.8	.0	.073	.002	30.1	1.1	SA	7					4			
		40.	4.7	.0	.055	.002	20.4	1.3										
		60.	4.7	.0	.046	.001	16.0	.5										
		80.	4.7	.0	.045	.001	12.4	.4										
		100.	4.6	.0	.037	.001	12.3	.4										
144.5	11.	20.	9.1	.2	.182	.003	8.8	.0	SH	4			5	5			3	
		40.	8.0	.1	.215	.003	4.0	.0										
		60.	7.5	.1	.224	.001	2.6	.0										
		80.	7.1	.1	.226	.004	2.0	.0										
		100.	6.9	.1	.213	.007	1.7	.1										

See notes at end of table.

TABLE A-1. - Experimental data--Continued

DEPTH (M)	MOIST. (PCT SAT)	FREQ. (MHZ)	DIELEC. CONST.		DISSIP. FACTOR		ATTEN. DIST. (M)		ROCK TYPE	MINERALS (VOL PCT)								
			MEAN	SDM	MEAN	SDM	MEAN	SDM		QU	CA	DO	MI	IL	PL	CH	CO	OP
146.9	11.	20.	7.6	.1	.197	.006	8.9	.3	SH	4	4	5	5	3	3	3	3	
		40.	6.5	.1	.147	.007	6.5	.3										
		60.	6.4	.1	.143	.007	4.5	.2										
		80.	6.4	.1	.140	.005	3.4	.1										
		100.	6.3	.1	.152	.011	2.6	.2										
150.0	6.	20.	9.4	.1	.119	.007	13.6	.9	SH/LI	7							3	
		40.	8.9	.1	.113	.007	7.4	.5										
		60.	8.7	.1	.103	.007	5.5	.4										
		80.	8.4	.1	.101	.007	4.2	.3										

Rock types: DO--dolomite, LI--limestone, SA--sandstone, SH--shale, SI--siltstone.

Minerals: QU--quartz, CA--calcite, DO--dolomite, MI--mica, IL--illite-kaolinite, PL--plagioclase, CH--chlorite, CO--coal, OP--opaques.

Numbers indicate the following volume percents: 3 = 5-10, 4 = 10-25, 5 = 25-50, 6 = 50-75, 7 = 75. Blank spaces indicate <5 vol pct.

APPENDIX B.--RELATIVE DIELECTRIC CONSTANT AND DISSIPATION FACTOR
OF NBS STANDARD GLASS

A bar of standard reference material (SRM) 711 glass was obtained from the National Bureau of Standards (NBS) and five 6.35-mm-thick slabs were cut, with a Pistorias diamond saw, from the original bar (specification 113). These sample plates were cemented between two ordinary glass plates with beeswax. A brass "biscuit cutter" and grade 120 carborundum were used to drill out 29.46-mm-diam disks. The disks were ground and lapped on an Ingram thin section grinder.

Before measurement, the samples were cleaned with acetone and stored in clean containers. During measurements, the samples were handled with gloved hands or tissue paper.

The results of the measurements are shown in table B-1. Each set (1 through 5) of experimental values was obtained by two equally qualified operators on different days. Room temperature was near 25.6° C during the tests, but room humidity conditions were unknown. All values were obtained at a frequency of 20 MHz.

The sample thickness was measured in accordance with American Society for Testing and Materials (ASTM) designation D374-57T, method A. The tabular values given are the mean (\bar{X}) and standard deviation (S) of five readings. The values of diameter are the mean and standard deviation of four readings.

As specified in the Type 1690-A Dielectric Sample Holder manual,¹ the sample diameter was smaller than the 50.8-mm electrode by at least five times the sample thickness in order to eliminate the error caused by the edge flux.

Two of the five samples (1 and 2) were coated with silver conducting paint to produce the most accurate dielectric constant values. The remaining three samples were left uncoated to produce the most accurate dissipation factor values.

¹General Radio Co. (West Concord, MA). Form 758-D, Aug. 1960.

TABLE B-1. - Relative dielectric constant and dissipation factor values for NBS standard glass¹

Disk	Thickness ($\bar{X} \pm S$), in	Diameter ($\bar{X} \pm S$), in	Relative dielectric constant ²	Dissipation factor ²
1	0.1301±0.0001	1.1465±0.0004	{ 7.14 7.16 }	} NAp
2	.1308± .0001	1.1486± .0012	{ 7.15 7.17 }	} NAp
3	.1302± .0003	1.1625± .0004	NAp	{ 0.00082 .00077 }
4	.1303± .0003	1.1627± .0010	NAp	{ .00075 .00078 }
5	.1301± .0001	1.1645± .0037	NAp	{ .00081 .00076 }

NAp Not applicable.

¹NBS glass specifications 113 (SRM 711).

²Experimental values were measured on 2 different days.

NOTE.--All values obtained at 20 MHz. No comparative data above 1 MHz available from NBS.