

RI 9209

RI 9209

REPORT OF INVESTIGATIONS/1988

U.S. Bureau of Mines
Mendenhall Research Center
1415 Randolph Ave.
MSB-30, WA 99207
LIBRARY

Closed Loop Control for a Continuous Mining Machine

By John J. Sammarco

BUREAU OF MINES



UNITED STATES DEPARTMENT OF THE INTERIOR

Report of Investigations 9209

Closed Loop Control for a Continuous Mining Machine

By John J. Sammarco

**UNITED STATES DEPARTMENT OF THE INTERIOR
Donald Paul Hodel, Secretary**

**BUREAU OF MINES
T S Ary, Director**

Library of Congress Cataloging in Publication Data:

Sammarco, John J.

Closed loop control for a continuous mining machine.

(Bureau of Mines report of investigations: 9209).

Includes Bibliography References.

Supt. of Docs. no.: I 28.27:9209.

1. Coal-mining machinery--Automatic control. I. Title. II. Series: Report of investigations (United States. Bureau of Mines); 9209.

TN23.U43 [TN813] 622 s [622'.234'028] 88-600171

CONTENTS

	<i>Page</i>
Abstract	1
Introduction	2
Machine operation	2
Control methodology	3
Tests	4
Machine instrumentation	4
Data acquisition	5
Open loop tests and results	5
Control mode	6
LAG time	7
Closed loop tests	8
Free space tests	8
Closed loop test results in free space	8
Coalcrete tests	8
Closed loop test results in coalcrete	10
Other control considerations	10
Initialization verification	10
Verification during operation	10
Future enhancements	12
Initialization verification	12
Verification during operation	12
Summary	12
Appendix A.—Sensor information	13
Appendix B.—Angle derivation	17

ILLUSTRATIONS

1. Open loop control	3
2. Closed loop control	3
3. Joy 16CM sensor locations	4
4. Full-scale response, shear up and shear down	5
5. Conveyor elevation lower, step function	6
6. On-off set points for negative and positive error	6
7. Lag time (off) components for shear down	8
8. Conveyor elevation to 2.4°, 13°, and return to 2.4°	9
9. Sequence 1, cutting cycle	9
10. Sequence 2, cutting cycle	10
11. Watchdog timer circuit	11
B-1. Shear angles	17

TABLES

1. Open loop test results for primitive function arcs in free space	5
2. Open loop test results for lag time and rate of change in free space	6
3. Open loop test results for lag time and rate of change in free space for tramming functions	6
4. Set point direction	7
5. Set point levels	8
6. Closed loop test results in free space for a fixed target	8
7. Closed loop test results in coalcrete	10

UNIT OF MEASURE ABBREVIATIONS USED IN THIS REPORT

a	ampere	mV	millivolt
°C	degree Celsius	mΩ	milliohm
°F	degree Fahrenheit	MF	megafared
deg	degree	μF	microfared
deg/s	degree per second	μm	micrometer
ft	foot	ppv	part per volume
ft/s	foot per second	psi	pound per square inch
g	gram	psia	pound per square inch, absolute
gpm	gallon per minute	psid	pound per square inch, differential
Hz	hertz	psig	pound per square inch, gauge
in	inch	s	second
kHz	kilohertz	V	volt
kΩ	kilohm	V ac	volt, alternating current
lb/ft ³	pound per cubic foot	V dc	volt, direct current
lb/in ³	pound per cubic inch	V dc/deg	volt, direct current, per degree
mA	milliampere	W	watt
ms	millisecond		

CLOSED LOOP CONTROL FOR A CONTINUOUS MINING MACHINE

By John J Sammarco¹

ABSTRACT

As part of a project to automate coal extraction, computer control of a continuous mining machine test bed has been developed and tested by the Bureau of Mines. A computer system and control software were developed for accurate positioning of the conveyor elevation and swing, stabilizer jack, gathering head, and shear elevation. Trimming actions are also controlled by the computer. The computer system was designed to access data from sensors installed on a continuous miner and to interface with the existing control circuits of the miner. Testing in free space was used to characterize the operation of the machine. From this information, control algorithms were written and stored in the computer.

The ability to control each function of the continuous miner with a high degree of accuracy and stability was successfully demonstrated in a series of tests in free space and in mining a block of simulated coal. In the mining of simulated coal, the cutting drum was instructed to position the shearer at the top of the block and shear down to the bottom under closed loop control. The cutting drum came within 0.27 in of the top and within 0.49 in of the bottom of the block for this shearing test.

¹Electrical engineer, Pittsburgh Research Center, Bureau of Mines, Pittsburgh, PA.

INTRODUCTION

Establishing accurate, computer-based control of a continuous mining machine is the first step in the development of autonomous, robotic mining equipment. With autonomous operation of a continuous mining machine, improvements in safety would be realized by removing workers from hazardous areas and relieving them of dangerous tasks. Also, productivity gains could be realized by optimizing machine operation. Autonomous operation will require integration of many subsystems in the areas of control, navigation, and positioning of the mining machinery.

This first step, establishing closed loop computer control of the machine functions, has been completed. A Joy 16 CM² continuous mining machine was used as a

test bed with control implemented by an on-board computer system based on the Intel 80286 microprocessor. This computer was responsible for data acquisition and control of all machine functions. A terminal connected to the computer was used to access various application programs used to test and operate the machine. This report describes an approach taken to test the machine and generate the algorithms for the closed loop control. The technology described may be applied to various continuous mining machines that utilize on-off control. Machines using proportional control valves may derive more benefit from other types of control.

MACHINE OPERATION

A Joy 16 CM continuous mining machine³ was used as the test bed. Functions of the machine under computer control are defined as primitive functions and are classified into three groups: Group 1—electrohydraulic functions, group 2—tramming functions; and group 3—latching functions. A description of each follows:

Group 1—Electrohydraulic Functions

Conveyor up	Shear down
Conveyor down	Stab jack up
Conveyor swing left	Stab jack down
Conveyor swing right	Gathering head up
Shear up	Gathering head down

These functions are controlled by an electrically actuated hydraulic circuit in which each function has two states, on and off. Actuation of an electrical relay activates the solenoid of a hydraulic pilot valve. This directs hydraulic fluid into or out of hydraulic cylinders thus causing movement of the function. For example, to raise the conveyor the conveyor up relay is energized. Deenergizing this circuit will stop the motion. To lower the conveyor the conveyor down relay is energized. Deenergizing this circuit will stop the motion. Movement of group 1 primitive functions, except in the case of the gathering head, can be stopped at any time regardless of movement direction. The gathering head has a float position in which it will drop to the ground level and

follow the contour of the mine floor as the mining machine moves. Once the gathering head is instructed to go down, it will not stop until it reaches the ground.

Group 2—Tramming functions

Tram forward slow	Pivot right
Tram forward fast	Tram reverse left
Tram reverse right	Tram reverse slow
Tram forward left	Tram reverse fast
Pivot left	Tram forward right

These are electrically controlled functions where a separate tramming motor exists for each the left and right crawler track. Each tramming function has an on and an off state.

Group 3—Latching Functions

Pump motor control	Reverse conveyor direction
Cutting head motor control	Control safety relay
Conveyor forward direction	

These are electrically controlled functions that have an on and an off state. They are designated as latching functions because they typically remain on when the Joy 16CM is in operation.

²Reference to specific products does not imply endorsement by the Bureau of Mines.

³Joy Manufacturing Co. (Franklin, PA). Miner Hydraulics. Sec. in Technical Service Manual for Joy 16CM. 1980, pp. 23-50.

CONTROL METHODOLOGY

The two basic systems of control considered were open loop control and closed loop control.⁴ Each type of control will be briefly discussed along with the reasoning to support selection of the appropriate control.

With open loop control, the system under control receives a request at the input for a desired output state of the system. The system will give a fixed response to that particular input request. No feedback or monitoring of the output is conducted. Figure 1 depicts such a control system. This type of system requires a high degree of calibration, system predictability, and the absence of internal or external disturbances that could alter the desired output of the system. An example of open loop control of the shear position follows.

If the rate at which the mining machine could shear was 2 deg/s, open loop control would activate the shearing action 10 s to shear through an angle of 20°. However, shear rates vary and could change because of external factors such as cutting into rock, which could decrease the shear rate. Shear rates will also vary for different seams of coal or by the depth the cutting head was sumped into the face. Therefore, shearing for 10 s may move through a shearing angle of 20° in one circumstance but only move 10° under another situation. As a result, it would be difficult to shear up or down accurately in an open loop mode based on time.

With closed loop control, the system output is measured and then compared to a desired state requested at the input. When the measured output is below or above the desired state, the system is controlled until the desired output level is reached. Therefore, closed loop control employs feedback that enables the control system to monitor the output and, if needed, correct for changes due to internal and external disturbances or for unpredictable system responses. A closed loop control system is depicted in figure 2.

The use of closed loop control was selected based on the operating environment and the characteristics of the machine. Many variables exist in the mining environment that could adversely affect the desired output of the mining machine. With closed loop control the effects of these disturbances can be monitored. Corrections can be made to maintain the desired output state.

Closed loop control was used for all group 1 primitive functions. The tramming functions of group 2 are controlled by the open loop method where a time duration is given to achieve linear distance or degrees for turning. Tramming functions remain under open loop control only for this stage of development. These functions are to be controlled by the navigation and positioning control system under development; therefore, efforts were not concentrated on closed loop control of tramming functions. Open loop control was utilized because it could readily be implemented. Group 3 functions were simply turned on or off as they were needed.



Figure 1.—Open loop control.

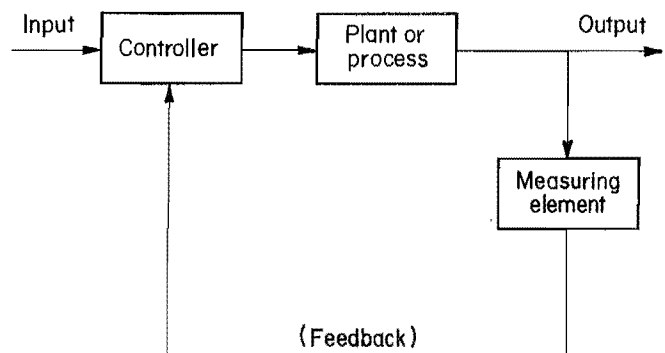

Figure 2.—Closed loop control.

⁴Ogata, K. Modern Control Engineering. Prentice-Hall, 1970, pp. 1-14.

TESTS

Tests were conducted under open loop and closed loop control to determine the dynamic operating characteristics of the machine. Open loop test information was used to determine the form of the algorithm to be used for closed loop control. After the closed loop control system was designed, it was tested in free space and in a simulated coal seam known as coalcrete. The coalcrete had an average compressive strength of 94.5 lb/ft³ (4,636.4 lb/in³). Its composition was 10 ppv 1.5- to 2-in nominal coal, 8 ppv fly ash, 1 ppv cement, and 1.5 ppv water.

the miner. Sensors used for measuring movement were rotary variable differential transformers (RVDT's). These devices change the magnitude of their voltage output as the angular positions of their shafts change. Flow, pressure, and temperature of the hydraulic fluid were also measured. Figure 3 depicts the location of the sensors on the mining machine. Detailed sensor information is given in appendix A. Instrumentation also included proper signal conditioning devices to insure signal integrity and to facilitate interfacing to the Intel 80286 based on-board computer.

MACHINE INSTRUMENTATION

The mining machine was equipped with sensors to measure the position of all the movable parts of

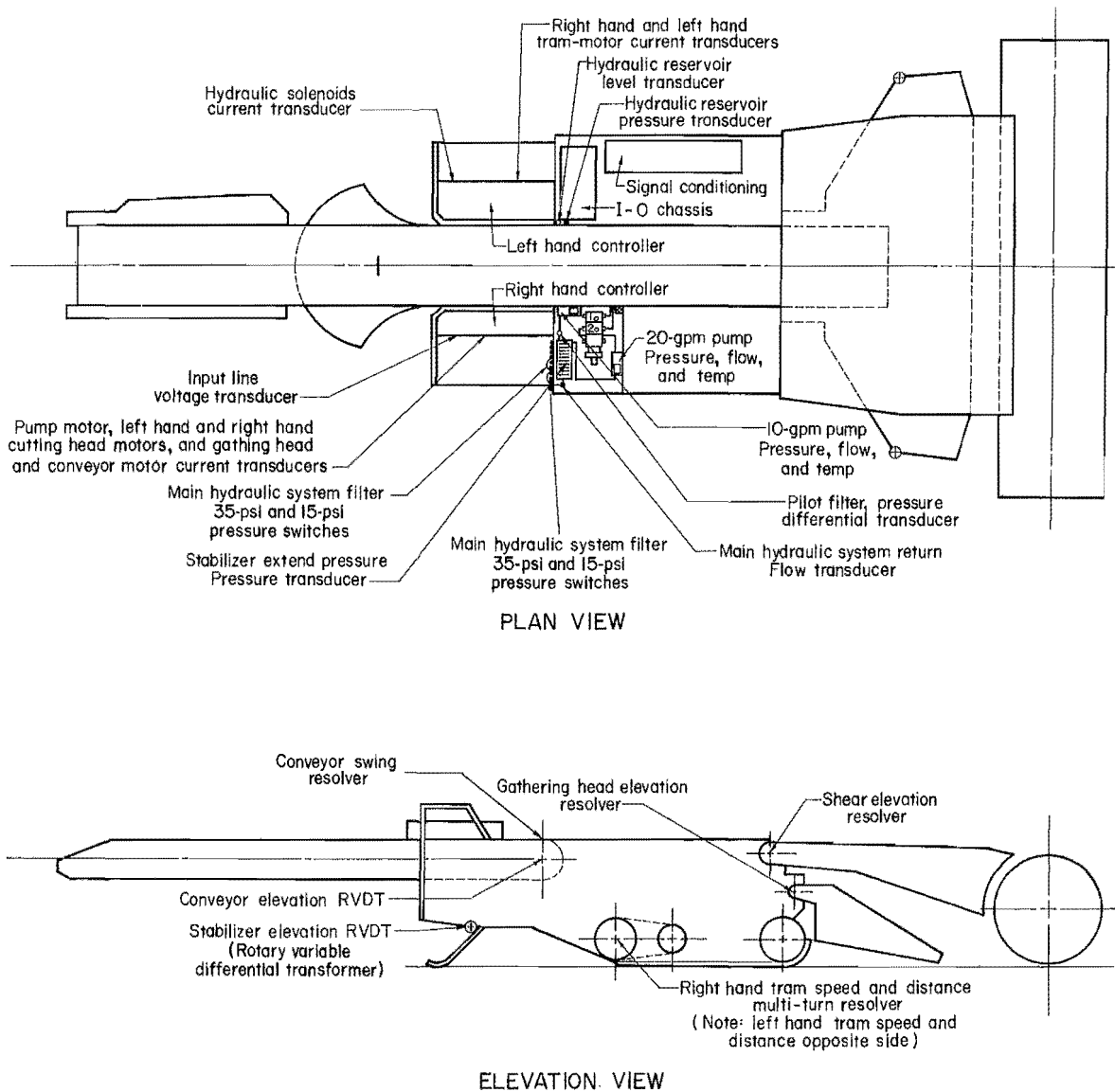

Figure 3.—Joy 16CM sensor locations.

DATA ACQUISITION

Sensor and control signals were recorded on two Honeywell model 101 FM recorders during all phases of testing. The signals recorded were from three distinct areas:

1. Sensor signals for primitive function movement.
2. Control signals from the computer to the actuators of the machine.
3. Sensor signals concerning monitoring operating characteristics such as pump pressure, line voltage and current, and pump flow.

All sensor signals were recorded at the output of signal conditioning modules that provided amplification and electrical isolation. Control signals from the computer were logic level signals used to actuate the relays of the machine. A logic level 1 turned on a relay and logic level 0 turned it off. Once all the signals were recorded, they were digitized and transferred to a VAX 780 computer for analysis.

OPEN LOOP TESTS AND RESULTS

Open loop tests were conducted to determine the fundamental operating parameters of the machine. Two types of open loop tests were performed. The first was to determine the full-scale response characteristics and the second was to determine the response of the machine to a step function request. All full-scale response tests were executed three times in order to determine the repeatability of each primitive function. Trimming function tests were not subjected to replication because control of trimming functions was not of primary importance at this stage of development.

First, the full-scale response tests enabled measurement of the rate and range of movement for group 1 and 2 primitive functions. Rate was determined by a linear best fit of the signal slope in the range of 10% to 90% of the maximum signal.

Next, step function responses were conducted. Each primitive function was turned on for 2 s and the response was recorded. Lag time was measured for the turning on and off of each primitive function. (Lag time is measured from the instant the computer sends an electrical signal to activate a primitive function to the instant that movement of the primitive function is detected.) Finally, the response of each primitive function was graphed and then visually inspected for stability of the sensor response.

The test results in table 1 were obtained from the full-scale response tests under open loop control. The measured maximum is the change in degrees from the minimum to the maximum position attainable on the mining machine. The absolute maximum is the maximum value attainable from the sensor circuitry. Each test was repeated three times to determine repeatability.

TABLE 1. - Open loop test results for primitive function arcs in free space, degrees

Primitive function	Measured maximum	Std dev	Absolute maximum
Conveyor up	17	0.01	20
Conveyor down	17	.06	20
Conveyor swing left	90	.14	95
Conveyor swing right	90	.05	95
Shear up	43.5	.28	50
Shear down	43.5	.09	50
Stab jack up	34.5	.11	40
Stab jack down	34.5	.03	40
Gathering head up	20	.29	25
Gathering head down	20	.03	25

Table 2 gives the lag time and the rate at which each primitive function will change as determined by the open loop tests. Figure 4 plots full-scale tests for shear elevation. Note that no disturbances are evident in the signal and that the rate of change is very constant. A r^2 value of 0.99 was calculated for this curve. This r^2 value is a statistical measure in which a perfect linear fit would have an r^2 value of 1.00. Therefore, r^2 reflects the proportion of the total variation from a linear fit of the data. Figure 5 depicts the step function response of the conveyor elevation. The start and stop lag time was determined from the step function response.

Table 3 gives the lag time and the rate at which each trimming function will change as determined by the open loop tests. These trimming data depend on the amount of

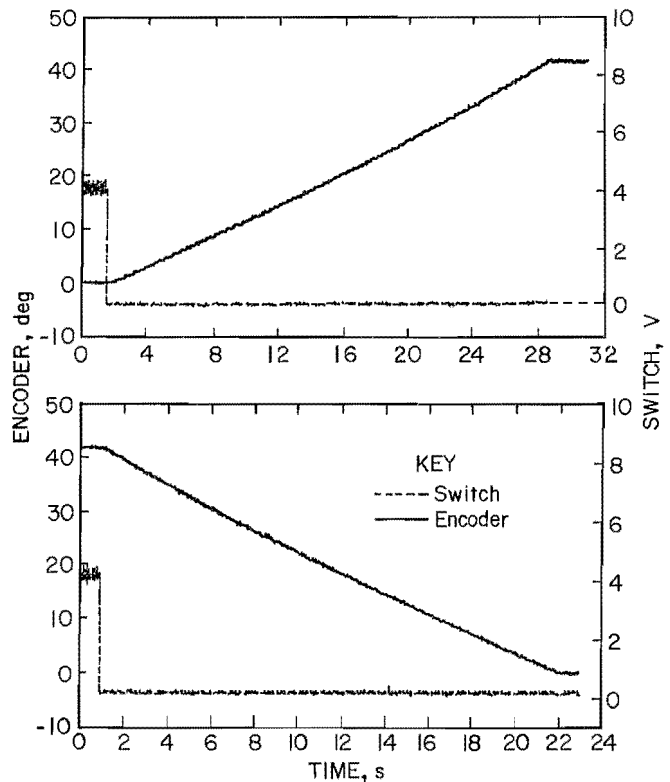

Figure 4.—Full-scale response, shear up (top) and shear down (bottom).

TABLE 2. - Open loop test results for lag time and rate of change in free space

Primitive function	Rate of change, deg/s	Std dev	Start lag time, s	Std dev	Stop lag time, s
Conveyor up	4.4	0.01	0.26	0.00	0.27
Conveyor down	3.9	.04	.30	.01	.29
Conveyor swing left	11.8	.02	.33	.01	.32
Conveyor swing right	12.6	.29	.28	.03	.28
Shear up	1.5	.00	.56	.05	.16
Shear down	2.0	.00	.36	.02	.24
Stab jack up	13.2	.00	.13	.01	.14
Stab jack down	9.7	.01	.12	.00	.06
Gathering head up	7.7	.56	.38	.01	.24
Gathering head down	22.6	.03	.24	.01	NA

NA None available.

TABLE 3. - Open loop test results for lag time and rate of change in free space for tramming functions

Primitive function	Rate of change	Lag time, s	
		Start	Stop
Tram forward slow	0.270 ft/s	0.32	0.40
Tram forward fast	0.540 ft/s	.40	.80
Tram rev. slow	0.270 ft/s	.32	.34
Tram rev. fast	0.540 ft/s	.38	.40
Pivot left	3.230	.34	.46
Pivot right	3.310	.32	.46
Tram rev. left	1.670	.32	.54
Tram rev. right	1.640	.30	.50
Tram forward left	1.670	.30	.52
Tram forward right	1.640	.34	.38

slippage encountered between the floor and the tramming tracks. Tests were conducted on a concrete floor for a tramming distance of 30 ft.

CONTROL MODE

The analysis of open loop test data showed that an on-off control mode would be well suited, since sensor responses exhibited virtually no oscillations for the step function tests and since the system movements were slow. Also, an on-off control mode could easily be used with the existing Joy 16CM control system hardware. Operation of a basic on-off control is also quite simple.⁵ When sensor (feedback) signals reach a certain level, the system is turned on or off depending on the desired output. Action of the on-off control is based on an error signal that is the difference between the present value (PV) of the system output and the desired value or target (T): $E = PV - T$.

A positive error results when the system output exceeds the desired value and a negative error results when the output is below the target. Various levels or set points are used to activate (turn on) a function or to stop (turn off) a function. The set point names are prefixed by EX (exceed) and DEP (deplete). When the present system output exceeds a desired output state, a positive error results and the EX set points are used. When the present system output is below a desired output state, a negative error results and the DEP set points are used. Figure 6 depicts the set points used for a negative error and a positive error. These set points can be further defined as follows.

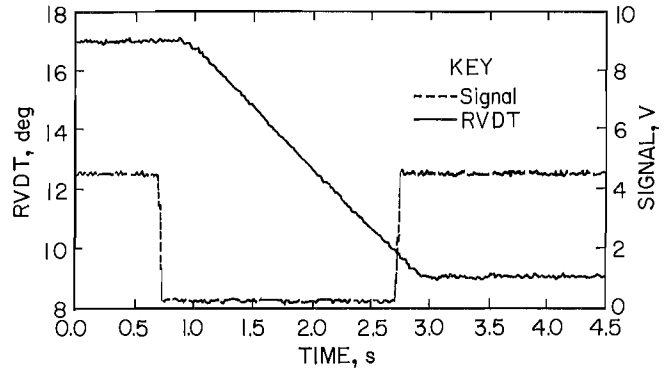

Figure 5.—Conveyor elevation lower, step function.

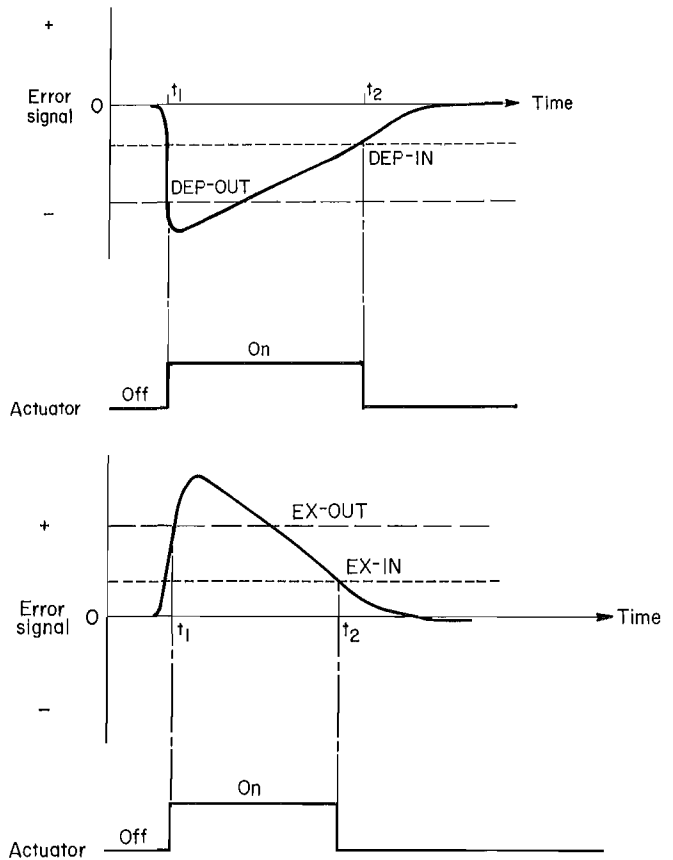

Figure 6.—On-off set points for negative (top) and positive (bottom) error.

⁵Bibbero, R. J. Microprocessors in Instruments and Control. Wiley, 1977, pp. 42-44.

DEP-OUT.—Error level greater than or equal to this set point starts movement of the primitive function in order to correct the error. Direction of movement in this state is either up or left depending on the primitive function under control.

DEP-IN.—Limit at which correction of error is stopped. Error is assumed to be corrected at this point. This set point is recognized only if DEP-OUT set point was exceeded.

EX-OUT.—Error level greater than or equal to this set point starts movement of the primitive function in order to correct the error. Direction of movement in this state is either down or right depending on the primitive function under control.

EX-IN.—Limit at which correction of error is stopped. Error is assumed to be corrected at this point. This set point is recognized only if ex-out set point was exceeded.

Table 4 lists the direction of movement for the group primitive functions once the error has exceeded the DEP-OUT or EX-OUT set points. Control of the gathering head will be in the up position only. Requests for the down position will put the gathering head in the float position.

An example of on-off control pertaining to figure 6 is as follows: The desired position of the conveyor is 12° at time t¹. The present value of the conveyor elevation is 8°, therefore the error is a negative 4°. If DEP-OUT set point is negative 2°, for this example, the error will exceed the DEP-OUT set point causing the actuator for raising the conveyor to turn on. As the conveyor approaches the target of 12°, the error signal decreases. Once the error signal reaches DEP-IN at time t², the actuator is turned off to stop movement. The DEP-IN set point is used to anticipate the additional movement or overshoot of the conveyor once the signal to stop conveyor movement is given. Set points are calculated for the conveyor elevation in the following example.

DEP-OUT is the level at which the conveyor will be activated up and EX-OUT is the level at which the conveyor will be activated down. For example, assume zero error and the magnitude DEP-OUT equals EX-OUT at a value of 1.9°. The on-off control will ignore target values until the error exceeds the set point of 1.9°. It can be thought of that the one-off control has a sensitivity of 1.9°, as referenced to a zero error. Therefore, in this example, the smallest "step" that the on-off control can take is 1.9°. It is desirable to have DEP-OUT and EX-OUT at some level other than zero to prevent needless actuation of the system by correcting for insignificant errors. The DEP-OUT and EX-OUT points for the

conveyor were calculated as follows: Conveyor arc = 17°, desired number of steps = 9, and degrees for each step = 17°/9 steps or 1.9° per step. The distance traveled in 1.9° is about 5.8 in.

The DEP-IN and EX-IN set points are the levels in which corrective action is instructed to stop. These set points are calculated as follows: DEP-IN = (total delay time) dθ/dt, and total delay time = time lag (off) + sample time + program execution time.

The third term, program execution time, can be dropped since it is insignificant. Sample time is the rate at which the computer was instructed to read the output of the sensor. Sample time was 0.005 s. Therefore, calculation of DEP-IN for the conveyor elevation is total delay time = 0.27 s + 0.005 s or 0.275 s.

The rate of change for the conveyor is 4.4 deg/s in the upward direction. DEP-IN = 0.275 X 4.4 deg/s or 1.21°.

Rounding off to tenths of a degree gives DEP-IN = 1.2°. EX-IN is calculated using the same method where total delay time = 0.29 s + 0.005 s or 0.295 s. The rate of change for the conveyor is 3.9 deg/s in the downward direction. EX-IN + 0.295 s X 3.9 deg/s or 1.15°. Rounding off to tenths of a degree gives EX-IN = 1.2°.

LAG TIME

The calculation of the DEP-IN and EX-IN set points can vary significantly with lag time variations if the motion of the primitive is very fast. With a rate of change of 12 deg/s, a lag time of 0.29 s, and a sample time of 0.005 s, a DEP-IN of 4.1° is calculated. If the lag time increases 15%, the new value required for DEP-IN is 4.6°. Unless it is possible to compensate for or adapt to this lag time variation, a 0.6° error will result in this example. An adaptive control could be implemented in future work to improve accuracy. At this point, the components that make up lag time and what can cause it to change are discussed.

Lag time consists of two components; the time response of the electrical system and the time response of the hydraulic system. Figure 7 depicts these components for the lag time (off) of the shear in the down direction. The largest component is from the hydraulic system. Lag time in this system will depend on the response of the pilot valves due to pilot pressure and actuator pressure. As pilot pressure decreases, the response of the pilot valves should increase. With this information, an adaptive control system could be designed. The lag times used in the set point calculations would be modified according to the pilot pressure thus maintaining control accuracy.

It is important that the difference between DEP-OUT and DEP-IN (and EX-OUT and EX-IN) is sufficiently large to prevent false triggering from noise on the sensor signals. This difference is 0.70° for the conveyor elevation set points and is well above the 0.15° of noise measured on the conveyor elevation signal.

Set point levels used for all primitive functions are listed in table 5.

TABLE 4. - Set point direction

Function	EX-OUT	DEP-OUT
Conveyor	Down ..	Up.
Conveyor swing	Right ..	Left.
Shear elevation	Down ..	Up.
Stab jackdo i . . .	Up.
Gathering headdo i . . .	Up.

¹Float.

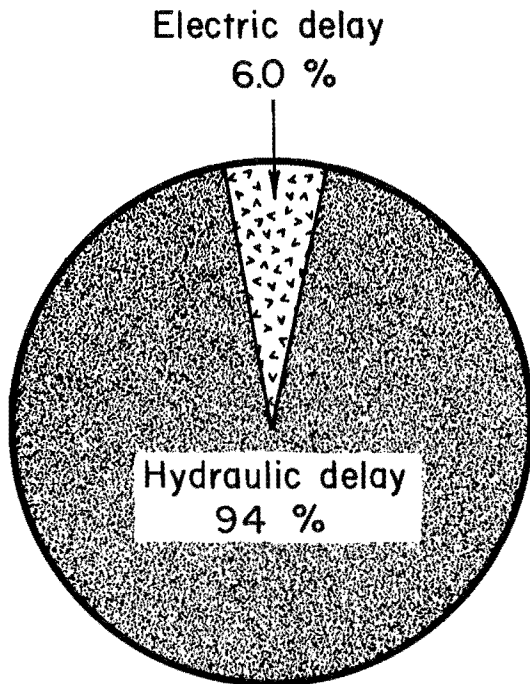

Figure 7.—Lag time (off) components for shear down.

TABLE 5. - Set point levels, degrees

Primitive function	EX-OUT	EX-IN	DEP-OUT	DEP-IN
Conveyor elevation .	1.9	1.2	1.9	1.2
Conveyor swing . . .	4.4	3.9	4.5	4.6
Shear elevation . . .	2.7	.4	2.7	.4
Stab jack	4.0	2.3	4.0	1.6
Gathering head . . .	2.9	2.2	2.9	2.2

CLOSED LOOP TESTS

Once the open loop test data were analyzed, the control mode and control set points (see table 5) for a closed loop system were determined. Static tests verified that each primitive function could be activated properly. Initialization tests recorded the initial zero offset and full scale output for each sensor. The closed loop test sequences were as follows:

1.0 Closed loop testing of primitive functions in free space.

1.1 Static test.

1.2 Initialization.

1.3 Dynamic testing of primitive functions.

2.0 Closed loop testing of primitive functions in coalcrete.

2.1 Static test.

2.2 Initialization.

2.3 Dynamic testing of primitive functions.

Free Space Tests

For this phase of testing, the primitive functions were given a target value. Each primitive function started at the bottom of its range and was instructed to reach three separate targets. The first target was a small step in the up or left direction. This tested the ability of the control to achieve a request for a small excursion. The next target required a much larger excursion in the same direction. This verified the accuracy of control starting from a point other than zero and meeting the request for a large excursion in movement. Next the primitive function was tested for its ability to return to the original requested level. Each of these test sequences was repeated three times.

Closed Loop Test Results in Free Space

Table 6 presents the accuracy of the control in free space. The actual value is an average of three tests for that particular primitive function. Figure 8 graphically depicts the closed loop test results in free space for conveyor elevation.

Coalcrete Tests

Shearing sequences were conducted under closed loop control. The main intent of this test was to determine the stability and accuracy of the closed loop control for the shearing primitive function under a load condition. It was thought the vibration of the machine may affect the shear position sensors thus causing control instability. The first sequence was as follows:

TABLE 6. - Closed loop test results in free space for a fixed target, degrees

Primitive function	Target	Average	Error	Std. dev.
Conveyor elevation . .	2.4	2.38	-0.02	0.12
	13	13.43	.43	.20
	2.40	2.57	.17	.10
Conveyor swing	20	19.67	-.33	.46
	70	69.36	-.64	.51
	20	20.58	.58	.21
Shear elevation	5	4.78	-.22	.08
	12.5	12.93	.43	.07
	5	4.97	-.03	.12
Stab Jack	4	4.75	.75	.38
	20	21.12	1.12	.74
	4	4.86	.86	.39
Gathering head	10	10.37	.37	.57
	20	19.54	-.46	.08

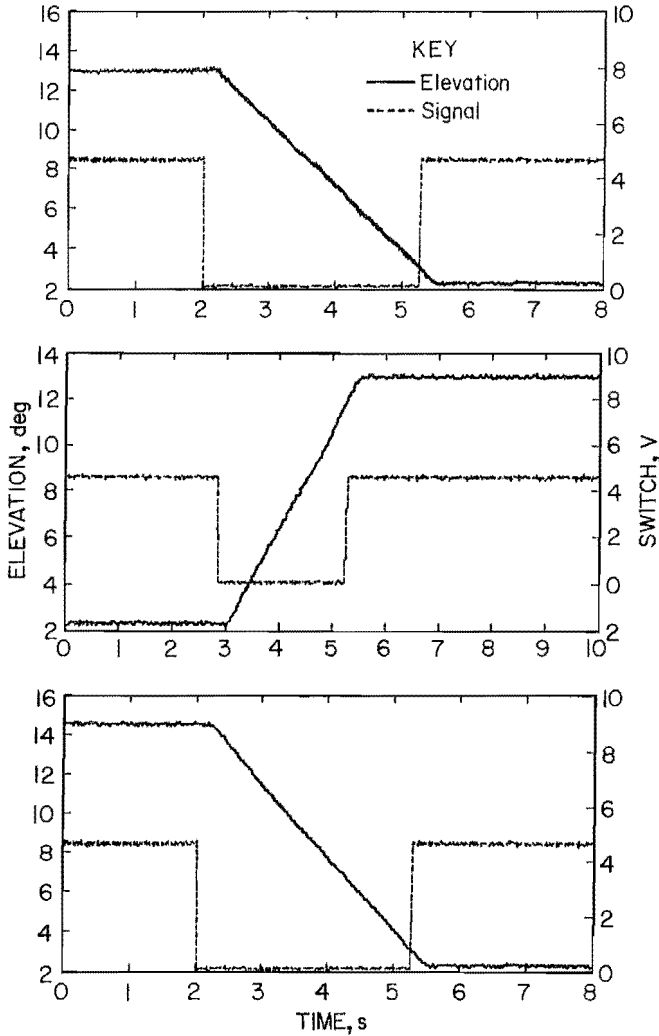

Figure 8.—Conveyor elevation to 2.4° (top), 13° (middle), and return to 2.4° (bottom).

Sequence 1 (fig. 9)

- Raise shear to 21° (top of coalcrete block).
- Tram forward slow to front of coalcrete face.
- Turn the conveyor on to the forward position.
- Turn the cutting motors on.
- Lower the stabilizing jack 20°.

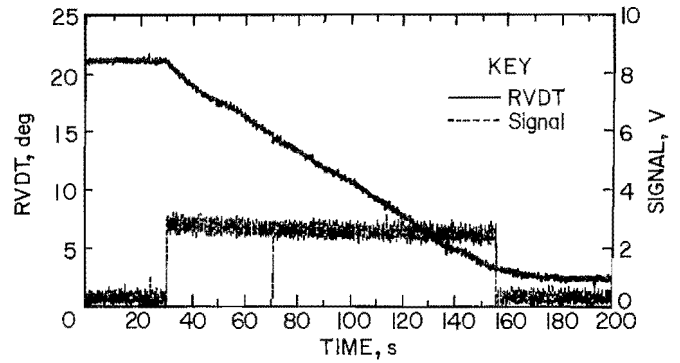

Figure 9.—Sequence 1, cutting cycle.

Sump in a full diameter of the shear drum by tramping forward slowly, 40 s.⁶

Shear down to 2.7° (floor level).

In this sequence the cutting drum was sumped into the face approximately 39 in. (full diameter) at the top of the coalcrete block (height of coalcrete block was 6 ft) and sheared to the bottom of the block.

Sequence 2 (fig. 10)

Raise shear from 2.7° to 12.5°.

Sump in a full diameter of the shear drum by tramping forward slowly, 40 s.

Shear up to 26° (this will clear the top of the coalcrete block).

Shear down to 9.2°.

Shear down to 2.7°.

Raise stabilizer jack to 34°.

Turn conveyor off.

Turn cutting motors off.

Tram low speed reverse for 40 s.

⁶Because of slippage of the tramping tracks on the concrete floor, it was required tram forward for approximately 40 s to achieve the proper sump depth.

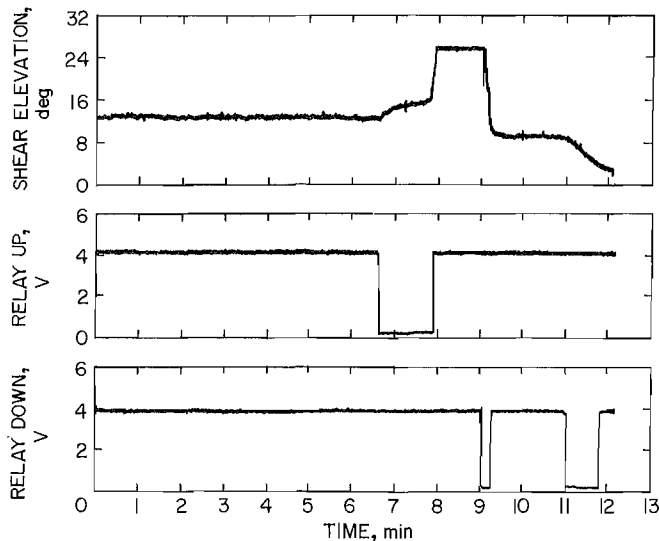

Figure 10.—Sequence 2, cutting cycle.

In sequence 2, the cutting drum was sumped into the face approximately 39 in. at the middle of the coalcrete block and sheared to the top of the block. The cutting drum was then returned to the middle of the face where the shearing continued to the bottom.

Since the shear position is expressed in terms of degrees, it was necessary to relate vertical distance (measured from center to center of the cutting drum) to movement in degrees.

The vertical distance, c , for a given shear angle, C , is $c = 2a \sin(C/2)$, where a is the length of the cutting head arm. (See appendix B for derivation.)

This equation can be used for the conveyor elevation, gathering head elevation, and stab jack. The shear angle, C , is the angle of movement for the function and a is the length of the appendage from the pivot point. The length a is 110.5 in. for the conveyor, 84 in. for the gathering head, and 30 in. for the stab jack.

OTHER CONTROL CONSIDERATIONS

Many other factors must be taken into consideration when designing a computerized control system. One must verify that the machine and computer are in proper working order before the machine is permitted to go into operation. Once the machine is in operation, fault detection must be present to detect fault conditions and to implement operations to either correct the fault or bring the machine to a known safe condition depending on the type of fault detected. The following items have been implemented at this stage of development. Other fault detection items currently under investigation are also discussed.

INITIALIZATION VERIFICATION

Upon power up of the mining machine, the computer system will conduct a sequence of tests on its subsystems to verify proper operation.

TABLE 7. - Closed loop test results in coalcrete

	Target deg	Measured value, deg	Error	
			deg	In
Sequence 1	21	21.14	0.14	0.27
	2.7	2.44	.26	.49
Sequence 2	12.5	12.13	.37	.69
	26	25.68	.32	.60
	9	8.94	.06	.11
	2.7	2.71	.01	.02

Closed Loop Test Results in Coalcrete

The closed loop test results in coalcrete are summarized in figures 9 and 10. Figure 9 depicts sequence 1 for the closed loop tests in coalcrete while figure 10 depicts sequence 2. The rate of change for shear elevation depicted in figure 9 is 0.14 deg/s compared with 2.0 deg/s for shearing in free space. It is expected that the shearing rate would increase in coal because the average compressive strength of the coalcrete is 4,636.4 lb/in³ compared with 2,100 lb/in³ for coal in the Pittsburgh coal seam.⁷ In figure 10 the cutting drum has been sumped into the middle of the coalcrete block and is being sheared in an upward motion. Because the cutting drum was designed for downward shearing motions, the shearing action is less efficient for upward motion if the rate of change is used as a measure of efficiency. The rate of change for this condition was 0.04 deg/s versus 0.14 deg/s for the downward shearing action in figure 9. Observe the abrupt increase in rate at approximately 7.8 min for the shear elevation of figure 10. At this point the remaining coalcrete above the cutting drum fractured, decreasing the resistance to the shearing action to give a rate of 1.56 deg/s as compared with 2.0 deg/s for free space action.

Table 7 gives the measured values and the target values of shear elevation for sequence 1 and 2 of the closed loop test in coalcrete.

VERIFICATION DURING OPERATION

Two vital conditions of the microprocessor are monitored: 5-V dc power supplied to the microprocessor and the execution of software by the microprocessor. This is accomplished by the microprocessor supervisory circuit of figure 11.

The first function of this circuit is to monitor the 5-V dc power. If the power falls below 4.75 V dc, the circuit will deenergize the control safety relay thus stopping all activity of the mining machine and stopping further control from the microprocessor. This prevents an out-of-control situation as a result of a microprocessor malfunction.

⁷Lama, R. D., and V. S. Vutukuri. Handbook of Mechanical Properties of Rocks. Trans Tech Publ., v. 2, 1978, p. 331.

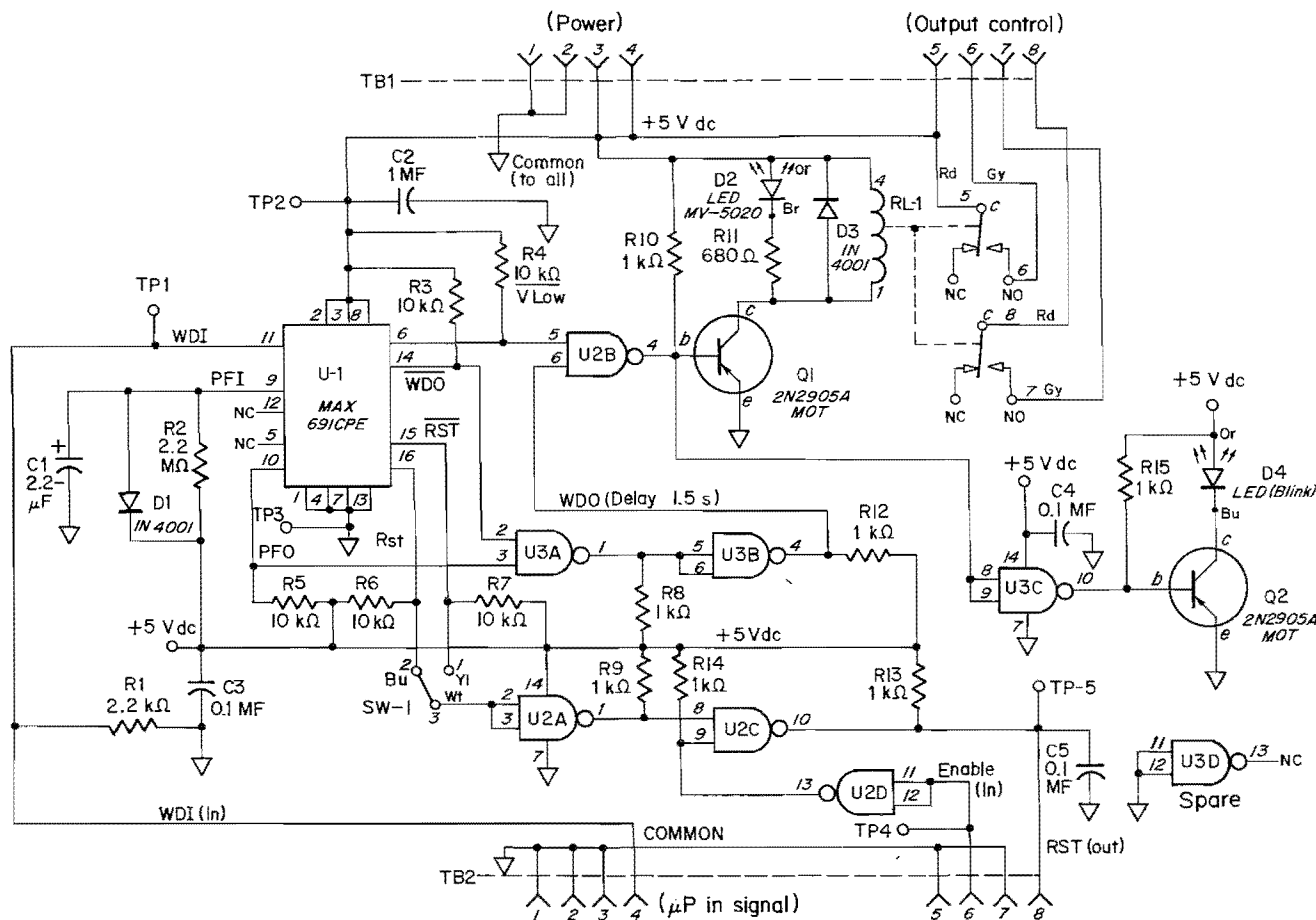

KEY

- WDI = 7.2 to 14 Hz 10 Hz nominal frequency in at TB2-4 (TTL)
- Enable In = (0 for reset) C4 pin 14 of micro-processor (μ P) backplane TB2-6 (TTL)
- RST (out) = Control to μ P unit (TTL)
- OPTO = Control output +5 Vdc/SW TB1-6
- U1 MAX691CPE, maxim 16 pin
- U2, 3 DM7401N (NS), 14 pin
- RL-1-ST2E-DC5-AROMAT
- Q1, 2 2N2905A (MOT) PNP
- D2 Run, LED 5082-4658R (HP), T 1³/₄
- D4 Fault, LED 276-036C (RS), T 1³/₄
- Enclosure, CU-124 (4³/₄ by 2³/₈ by 1³/₄ in) Bud box
- NC Normally closed, (relax), no connection, (IC)
- NO Normally open
- Color code
 - Rd Red
 - Gy Gray
 - Bu Blue
 - Wt White
 - Br Brown
 - Yl Yellow
 - Or Orange
- All resistors 1/4W unless noted otherwise
- MF = Microfarad
- WDO = Watchdog output
- WDI = Watchdog input
- PFI = Power fail input
- PFO = Power fail output
- RST = Reset

Figure 11.- Watchdog timer circuit.

The second function monitors software execution by reading a signal at the output port generated through

software every 0.05 s. Failure of the microprocessor to generate this signal will deenergize the control safety relay.

FUTURE ENHANCEMENTS

The following items are under investigation for use during the initialization process and also during dynamic operation of the mining machine to help maintain safe and accurate control.

3. Primitive function test. Each primitive function will be tested in free space for proper actuation and response. This testing must be successfully completed before further machine operation would be permitted.

INITIALIZATION VERIFICATION

1. Sensor autocalibration. The output of the sensors will be checked for proper calibration and recalibrated, if needed.

2. Vital function check. This check will verify that the vital parameters of the machine are at their proper level before operation of the machine can begin. Items checked will include the following:

Hydraulic pump flow, hydraulic pilot pressure, hydraulic fluid temperature, hydraulic reservoir level, line voltage, and line current.

A fault in these areas will be considered critical and machine operation will be suspended until the condition is remedied.

VERIFICATION DURING OPERATION

1. Range fault. Each sensor signal level is checked against the absolute maximum signal level for the functions in table 1. An out-of-range condition indicates a problem with the sensor circuitry.

2. Latching fault. The intent is to determine the unintended latching on of any primitive function. This may be implemented by observing the signal response after the primitive function has been instructed to stop. Continuation of the signal for a significant time could indicate a latched on condition at which time the control safety relay of the mining machine would be disabled thus stopping operation.

SUMMARY

Computer control of a Joy 16CM has been established. A computer system based on the Intel 80286 microprocessor was developed, and the machine was instrumented with sensors to measure the position of the machine's appendages. Analysis of open loop test data provided information to characterize the operation of the machine. Next, an on-off closed loop control scheme was designed, based on open loop test results, to precisely control the position of the machine's appendages. Operation of the on-off closed loop control was verified through tests in free space. Additional testing showed that the control accuracy was maintained while the mining

machine was subjected to vibration from the mining of a simulated coal seam.

The existing on-off closed loop control operation should be enhanced by adding verification tests on the sensors and the mining machine during the initial start up. The computer should also check for fault conditions during the operation of the machine and take appropriate action if a fault is detected. An adaptive control should be implemented that would monitor the machine and modify the control algorithms to the changing conditions of the machine to maintain control accuracy.

APPENDIX A.—SENSOR INFORMATION

The following sensors are used for control and diagnostic purposes for the Joy 16CM.

Type	Rotary variable differential transformer.
Model	R36-AS.
Manufacturer	Schaevitz.
Locations	Conveyor elevation, stabilizer elevation.
Output	+0.8756 V ac at +40°, -0.8756 V ac at -40°.
Amplified output ..	-40° = -10 V dc, +40° = +10 V dc, 0.250 V dc/deg amplified output.
Excitation	10 V rms at 2.5 kHz.
Linearity	1% of range.
Shock	Not available.
Vibration	Do.
Resolution	Infinite between ±40°.
Signal conditioning .	Analog transducer amplifier ATA-101.
Comments	The ATA-101 is powered by 110 V ac.
Type	Electromagnetic position, single turn.
Model	HST-26-CKU.
Manufacturer	Astrosystems Inc.
Locations	Conveyor swing, shear elevation, gathering head elevation.
Output	BCD 2,000 counts per turn, analog output = 0 to 10 V dc with accuracy of ±0.25%.
Excitation	Power supply model SP1008 (requires 115-230 V ac).
Linearity	0.05% (sensor only).
Shock	50 g for 11 ms.
Vibration	15 g to 2,000 Hz.
Resolution	0.18° per count or 27.8 mV/deg.
Signal conditioning .	Internal to system.
Comments	This sensor is part of model BEU-2002-N system.
Type	Electromagnetic position, multiturn.
Model	HMT-34-1/100-2KU.
Manufacturer	Astrosystems Inc.
Locations	Right tram, left tram.
Output	BCD 1,000 counts per turn, 100 turns per full count, total counts = 100,000 analog output = 0 to V dc.
Excitation	Power supply model PS 1008.
Linearity	±0.001%.
Shock	50 g for 11 ms.
Vibration	15 g to 2,000 Hz.
Resolution	1,000 counts (1 turn) per 360°.
Signal conditioning .	Internal to system.
Comments	This sensor is part of model BEU-2100-N measurement system.
Type	Flow transducer.
Model	FSC 1005 - 6H.
Manufacturer	Flo-Tech.
Location	Main hydraulic system return.
Output	0 to 10 V dc.
Excitation	Self-generating alternating pulse, 100 mV rms minimum.
Accuracy	±1% full scale.
Shock	Not available.
Vibration	Do.
Resolution	Infinite.
Signal conditioning .	Flow-Tech RSC10V frequency-to-voltage converter.
Comments	Flow rate, 4 to 85 gpm.

Type	Current sensor.
Model	CT100LT.
Manufacturer	Ohio Semitronics.
Locations	Gathering head-conveyor motor, right tram motor, left tram motor, hydraulic solenoids.
Output	CTA101 and CTA113; 50 mV at 100 A, amplified output = 10 V at 100 A.
Excitation	100 mA dc nominal.
Linearity	0.05% full scale.
Shock	Not available.
Vibration	Do.
Resolution	Infinite.
Signal conditioning .	CTA101 and CTA113 (hydraulic solenoids), 0 to 10 V dc out.
Comments	CTA101 and CTA113 require 110 V ac; sensor range, 0 to 100 A rms; each hydraulic solenoid requires 1 A.
Type	Current sensor.
Model	CT200LT.
Manufacturer	Ohio Semitronics.
Location	Pump motor.
Output	50 mV rms at 200 A, amplified output = 10 V at 200 A.
Excitation	100 mA dc nominal.
Linearity	0.05% full scale.
Shock	Not available.
Vibration	Do.
Resolution	Infinite.
Signal conditioning .	CTA113.
Comments	CTA113 requires 110 V ac; sensor range, 0 to 200 A rms.
Type	Current sensor.
Model	CT400LT.
Manufacturer	Ohio Semitronics.
Locations	Left-hand cutting head motor, right-hand cutting head motor.
Output	50 mV rms at 400 A, amplified output = 10 V at 400 A.
Excitation	100 mA nominal.
Linearity	0.5% full scale.
Shock	Not available.
Vibration	Do.
Resolution	Infinite.
Signal conditioning .	CTA113.
Comments	CTA113 requires 110 V ac; sensor range 0 to 400 A rms.
Type	Voltage sensor.
Model	10ps501.
Manufacturer	Transdata.
Location	Input line voltage.
Output	1 mA.
Excitation	External power = 115 V ac.
Linearity	±0.25% full scale.
Shock	Not available.
Vibration	Do.
Resolution	Infinite.
Signal conditioning .	Not available.
Comments	Input voltage range, 0 to 150 V.
Type	Level sensor.
Model	L2610.
Manufacturer	Princo.
Location	Hydraulic reservoir.
Output	4 to 20 mA dc.
Excitation	115 V ac.

Linearity 0.5% maximum.
 Shock Not available.
 Vibration Do.
 Resolution Infinite.
 Signal conditioning . Not available.
 Comments Span, 0.5 to 100 ft; maximum mounting distance, 50 ft.

Type Pressure, absolute.
 Model A5/5326-01.
 Manufacturer Sensotec.
 Location Hydraulic reservoir.
 Output 4 to 20 mA dc.
 Excitation 10 V dc.
 Accuracy $\pm 0.5\%$ full scale.
 Shock Not available.
 Vibration Do.
 Resolution Infinite.
 Signal conditioning . Not available.
 Comments 0- to 25-psia range.

Type Pressure, gauge.
 Model A5/1743-06.
 Manufacturer Sensotec.
 Location Stabilizer pressure.
 Output 30 mV dc.
 Excitation 10 V dc.
 Accuracy $\pm 0.5\%$ full scale.
 Shock Not available.
 Vibration Do.
 Resolution Infinite.
 Signal conditioning . Not available.
 Comments 0- to 5,000-psig range.

Type Pressure, differential.
 Model A5/5327-01.
 Manufacturer Sensotec.
 Location Pilot filter.
 Output 4 to 20 mA.
 Excitation 10 V dc.
 Accuracy $\pm 0.5\%$ full scale.
 Shock Not available.
 Vibration Do.
 Resolution Infinite.
 Signal conditioning . Not available.
 Comments 0- to 50-psid range.

Type Pressure switch.
 Model RC861CZ090H.
 Manufacturer DELTADYNE.
 Locations Main hydraulic system, main hydraulic system return.
 Output Electrical switch: 3-A inductive, 5-A resistive at 28 V dc.
 Excitation Not available.
 Accuracy ± 3 psid.
 Shock Not available.
 Vibration Do.
 Resolution Infinite.
 Signal conditioning . Not available.
 Comments 35-psi set point for 10- μ m filter in main hydraulic return.

Type	Pressure switch.
Model	RC861CZ084H.
Manufacturer	DELTADYNE.
Locations	Main hydraulic system, main hydraulic system return.
Output	Electrical switch; 3-A inductive, 5-A resistive at 28 V dc.
Excitation	Not available.
Accuracy	±5 psid.
Shock	Not available.
Vibration	Do.
Resolution	Infinite.
Signal conditioning .	Not available.
Comments	15-psi set point for 3- μ m filter in main hydraulic return.
Type	Pressure, flow, temperature.
Model	Testmate.
Manufacturer	Schroeder.
Location	20-gpm pump.
Output	Not available.
Excitation	Eight 1.5-V batteries.
Accuracy	Flow meter, ±1 gpm at 3 to 5 gpm, ±0.2 gpm at 6 to 20 gpm, ±2% full scale for high-scale pressure, ±35 psi at 0 to 1,000 psi.
Shock	Not available.
Vibration	Do.
Resolution	Infinite.
Signal conditioning .	Not available.
Comments	Temperature range, 50° to 250° F; flow scales, 0 to 20 gpm, 0 to 100 gpm; pressure scales, 0 to 1,000 psi, 0 to 6,000 psi.

APPENDIX B.—ANGLE DERIVATION

With an oblique triangle, the law of sines can be used where

$$a/\sin A = b/\sin B = c/\sin C.$$

Let $a = b =$ length of cutting head arm (109.25 in),
 $c =$ vertical distance,
 $C =$ shear angle,
 $A = B =$ shear angle with respect to vertical distance, as depicted in figure B-1.

Since angle $B =$ angle A for an oblique triangle and $A + B + C = 180$, then

$$A = 0.5 (180 - C).$$

Substituting these into the law of sines equation and solving for c (vertical distance traveled for a given shear angle, C):

$$c = a (\sin C/\sin A),$$

or $c = 2a \sin (C/2),$

or $c = 2[\text{arc sin}(c/2a)].$

Shear angle, C , for a given vertical distance, c .

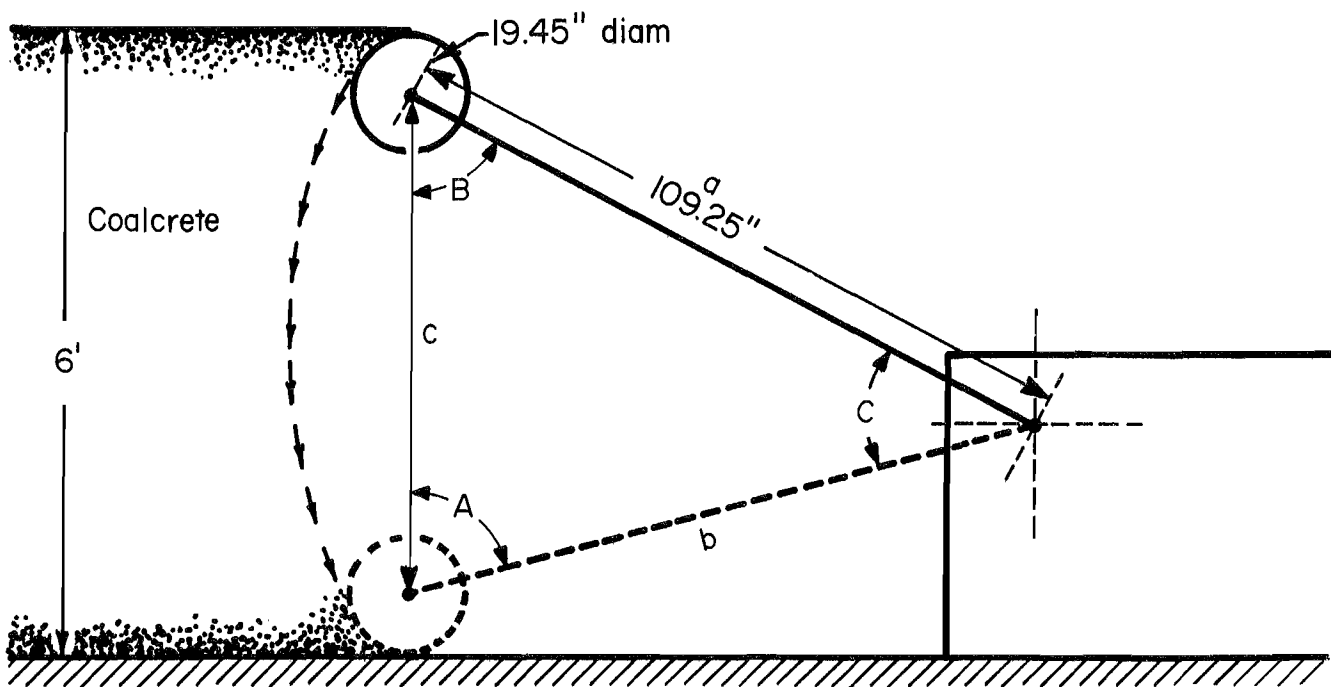

Figure B-1.—Shear angles.