

RI 8853

RI	8853
-----------	-------------

PLEASE DO NOT REMOVE FROM LIBRARY

Bureau of Mines Report of Investigations/1984

An Analyzer for Determining Helium-4 in the Parts-Per-Billion Range

By Philip W. Holland



UNITED STATES DEPARTMENT OF THE INTERIOR

Report of Investigations 8853

An Analyzer for Determining Helium-4 in the Parts-Per-Billion Range

By Philip W. Holland



UNITED STATES DEPARTMENT OF THE INTERIOR
William P. Clark, Secretary

BUREAU OF MINES
Robert C. Horton, Director

Library of Congress Cataloging in Publication Data:

Holland, Philip W

An analyzer for determining helium-4 in the parts-per-billion range.

(Report of investigations / Bureau of Mines ; 8853)

Bibliography: p. 9.

Supt. of Docs. no.: I 28,23:8853.

1. Helium--Isotopes--Analysis. 2. Gas-detectors. I. Title. II. Title: Analyzer for determining helium-four in the parts-per-billion range. III. Series: Report of investigations (United States. Bureau of Mines) ; 8853.

TN23.U43 [QD181.H4] 622s [622'.1897] 83-600353

CONTENTS

	<u>Page</u>
Abstract.....	1
Introduction.....	2
Acknowledgments.....	2
Description of analytical system.....	3
Procedures.....	4
Startup of the mass spectrometer.....	4
Regeneration of charcoal.....	4
Analysis of samples.....	6
Discussion of results.....	7
Linearity.....	7
Accuracy.....	8
Effect of sample flow.....	8
Calculations.....	8
Conclusions.....	9
References.....	9

ILLUSTRATIONS

1. Diagram of trace helium analyzer.....	3
2. Position of stream-switching and sample valves for purging sample loop and expanding reference gas and sample into mass spectrometer.....	5
3. Schematic diagram of electrometer.....	6

TABLES

1. Time programmed valve sequence for automated analysis.....	7
2. Integration parameters for quantization and plotting of helium peaks.....	7
3. Linearity of the method.....	7
4. Accuracy of the method.....	8

UNIT OF MEASURE ABBREVIATIONS USED IN THIS REPORT

°C	degree Celsius	μV	microvolt
cm	centimeter	μV/ppb	microvolt per part per billion
cm ³	cubic centimeter	min	minute
cm/min	centimeter per minute	mtorr	millitorr
cm ³ /min	cubic centimeter per minute	pct	percent
g	gram	pct/h	percent per hour
GΩ	gigohm	pF	picofarad
h	hour	ppb	parts per billion
in	inch	psi	pound per square inch
KΩ	kilohm	V	volt
μA	microampere	V ac	volt, alternating current
μF	microfarad	W	watt
MΩ	megohm		

AN ANALYZER FOR DETERMINING HELIUM-4 IN THE PARTS-PER-BILLION RANGE

By Philip W. Holland¹

ABSTRACT

The Bureau of Mines has developed a trace helium analyzer for determining helium-4 in the parts-per-billion range. The instrument is used for analyzing pure gases, laboratory-prepared standards, and atmospheric samples. Accuracy at the 95-pct confidence level in the 50- to 20,000-ppb range is within ± 2 ppb or ± 0.4 pct, whichever is greater. The minimum detectable helium-4 concentration is calculated to be 5 ppb.

The analyzer consists of a modified helium leak-detector mass spectrometer, a laboratory-built sample inlet system, and a liquid-nitrogen-cooled charcoal trap. A programmable integrator and event-control module make automatic operation possible. The portability of the analyzer allows it to be used in the field.

¹Chemist, Bureau of Mines, Helium Field Operations, Amarillo, TX.

INTRODUCTION

The Helium Act, Public Law 86-777, authorizes the Secretary of the Department of the Interior to maintain and operate helium production and purification plants. In pursuit of this mission, the Bureau of Mines is continually investigating ways to improve methods of helium production, purification, liquefaction, transportation, storage, and analysis.

The analyzer described in this report was developed to provide the capability to analyze for helium² in the 5- to 20,000-ppb range.

The instrument is used for determining the helium content in pure gases (excluding neon and hydrogen), laboratory-prepared secondary standards, and atmospheric samples.

Several researchers have designed and assembled helium leak-detector mass spectrometers for use as trace helium analyzers. Carter (1)³ used a helium leak detector to analyze gases extracted from water samples in evaluating the use of helium as a ground water tracer.

Friedman (2) and Reimer (3-4) of the U.S. Geological Survey assembled truck-mounted leak detectors for reconnaissance geochemical surveying. Their instruments are equipped with syringe-injection constant-pressure inlet systems. Gases other than helium and neon are removed from the injected sample using a liquid-nitrogen-cooled charcoal trap. Both

investigators reported a helium sensitivity of ± 10 ppb at the 5,000-ppb level.

Dyck (5) assembled a leak-detector mass spectrometer for field analysis of natural waters and soil gases in uranium reconnaissance. Dyck's inlet system is designed for batch-type sampling and has a special cap-punching device for sampling the air headspace in capped bottles.

A truck-mounted leak-detector mass spectrometer for uranium reconnaissance was described by Martin (6). This instrument is equipped with a syringe-injection batch-type sample inlet system. A chemical getter pump is used to remove noninert gases from the sample. Martin reported the same helium sensitivity as Friedman and Reimer did, ± 10 ppb at the 5,000-ppb level.

The trace helium analyzer designed by the Bureau employs a solenoid-controlled chromatographic gas-sampling valve to admit samples into the mass spectrometer. The sample is passed through the sample loop of the valve at approximately atmospheric pressure and expanded into the mass spectrometer through a liquid-nitrogen-cooled activated-charcoal trap. The flow of reference gas or sample gas to the sample valve is selectable using a second solenoid-controlled valve. All valve sequencing is controlled with a programmable integrator and event-control module to provide complete automation of the system.

ACKNOWLEDGMENTS

The author expresses his sincere thanks to Harold L. Rhodes, chemist, and George

M. Lucich, electronics engineer, for their technical assistance in the design of the sample inlet system and modification of the electronic circuitry of the leak-detector mass spectrometer. Both are with the Section of Technical and Analytical Services, Helium Field Operations, Bureau of Mines, Amarillo, TX.

²"Helium" in this report refers to the isotope helium-4.

³Underlined numbers in parentheses refer to items in the list of references at the end of this report.

DESCRIPTION OF ANALYTICAL SYSTEM

The analyzer consists of a modified Consolidated Electrodynamics Corp. (CEC)⁴ model 24-120A helium leak-detector mass spectrometer, a laboratory-built sample inlet system, and a liquid-nitrogen-cooled charcoal trap. A Hewlett-Packard model 3390A programmable reporting integrator and model 19400A event-control module were used to automate the system. The inlet system, integrator, and control module were installed in a 53- by 33- by 56-cm cabinet. Owing to its compact size and relatively low power requirements, the analyzer can be operated from the rear of a van or pickup using a 2,500-W, 115-V ac portable generator.

The essential components of the inlet system as--shown in figure 1--are the reference gas inlet port (A), sample inlet port (B), rotameter (C), stream-switching valve (1), sample valve (2), and air-switching solenoid valves (4 and 5). The inlet ports (A and B) are Cajon Ultra-Torr male connectors with rubber O-ring seals. Compressed gases are admitted to the ports via 1/16-in-OD⁵ stainless steel lines. The ports can be adapted for admission of samples via syringe by placing rubber septa under the retaining nuts of the connectors. Valves 1 and 2 are eight-port chromatographic valves actuated by compressed air (25

⁴Reference to specific products does not constitute endorsement by the Bureau of Mines.

⁵To convert inches to centimeters, multiply by 2.54.

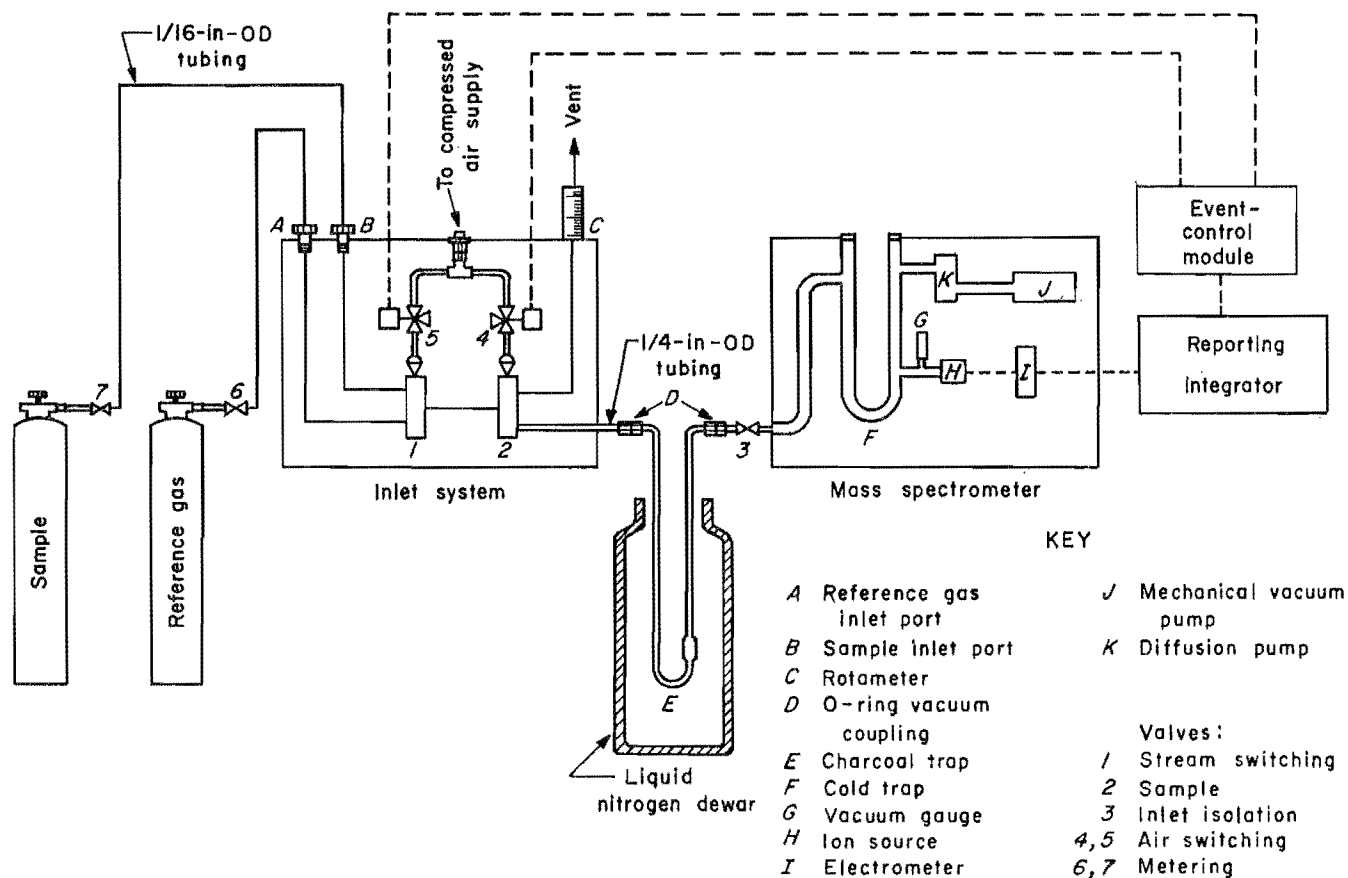

FIGURE 1. - Diagram of trace helium analyzer.

psi⁶) supplied through three-way solenoid valves 4 and 5.

Valve switching and sequencing is accomplished using the programmable integrator and event-control module. Manual or time-programmed signals control power to solenoid valves 4 and 5, thereby controlling the operation of valves 1 and 2. The operation sequence of valves 1 and 2 is programmed to provide alternate selection of the reference gas and sample streams. The 0.2-cm³ sample loop is purged for about 0.5 min with the gas to be analyzed. Flow through the loop is monitored at valve 2 using the rotameter (C). The positions of valves 1 and 2 for purging the sample loop and expanding samples into the mass spectrometer are shown in figure 2.

Samples enter the mass spectrometer through the charcoal trap (E in figure 1). The trap is a 1/4-in-OD (0.040-in wall) by 56-cm stainless steel U-tube with a 3/8-in-OD (0.040-in wall) by 5-cm enlargement, or "bulb," about 3 cm from the base (fig. 1). The bulb contains approximately 2 g of 40- to 60-mesh granular charcoal. The charcoal is held in place with stainless steel wool packing. At liquid nitrogen temperature, gases

other than helium and neon are adsorbed as the sample passes through the charcoal. Removal of these gases allows a larger volume of sample to be admitted into the mass spectrometer to achieve a higher helium pressure in the ion source. Thus, a higher electrometer output is achieved.

The mass spectrometer was modified by installing the electrometer diagramed in figure 3. The portion of the circuit located on the electrometer circuit board (fig. 3) was installed in the existing electrometer housing. The exterior of the housing was covered with foam rubber sheeting to minimize drift caused by temperature changes.

The circuit was assembled using commercially available components. An Analog Devices model AD515L operational amplifier was used for ion current amplification. A Victoreen type RX-1 glass-encapsulated resistor was used for the amplifier feedback resistor. A feedback resistance of 1,000 GΩ was selected to achieve a range of about 5 to 20,000 ppb He. Higher analytical ranges can be achieved by using feedback resistors of less than 1,000 GΩ.

PROCEDURES

STARTUP OF THE MASS SPECTROMETER

The procedure for startup of the mass spectrometer is as follows: With the charcoal trap (E) connected as shown in figure 1 and valve 3 closed, power to the mechanical vacuum pump (J) and the diffusion pump (K) is switched on. Pressure in the system is monitored using a vacuum gauge (G). After the pressure drops below 0.2 mtorr, the cold trap (F) is filled with liquid nitrogen. After the diffusion pump reaches its operating temperature (about 20 min), valve 3 is opened and the charcoal trap is evacuated. The filament in the ion source (H)

is then switched on, and the ionizing current and accelerator voltage are set at 50 μA and 70 V, respectively. The electrometer attenuator is set at the X10 position. About 2 h is required for temperature stabilization of the ion source.

REGENERATION OF CHARCOAL

The charcoal in trap E (fig. 1) is regenerated prior to each day's operation by heating while under vacuum. Regeneration removes adsorbed gases and water from the charcoal. The procedure is as follows: With valve 3 open, the bulb in the trap is heated at about 200° C for 1 to 2 min using a heat gun. The source of heat is then removed and the trap is allowed to cool to room temperature. (If the pressure in the mass spectrometer

⁶To convert pounds (force) per square inch to kilopascals, multiply by 6.894757.

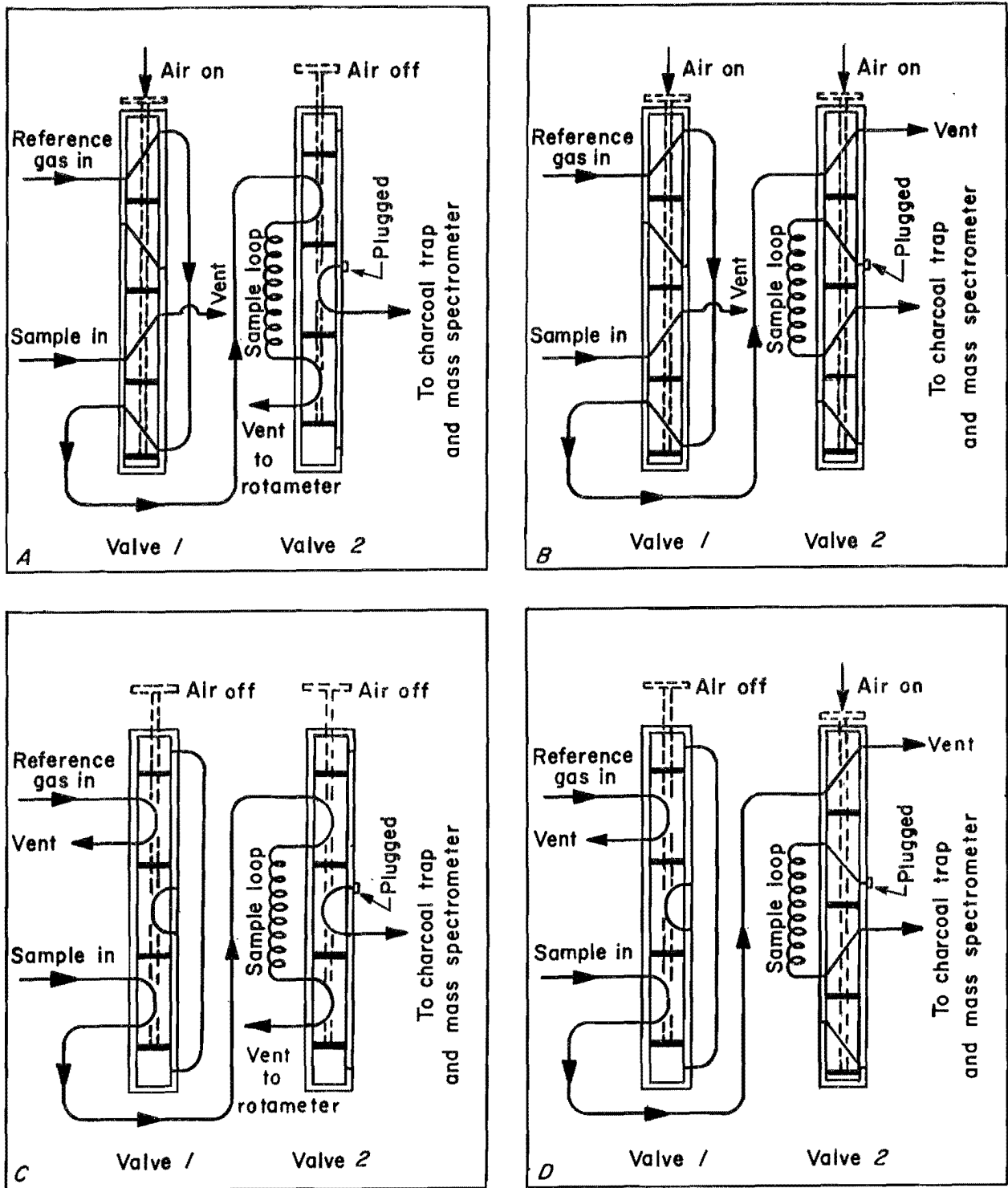

FIGURE 2. - Position of stream-switching and sample valves (valves 1 and 2 as shown in figure 1) for purging sample loop and expanding reference gas and sample into mass spectrometer. *A*, Purging sample loop with reference gas; *B*, expansion of reference gas; *C*, purging sample loop with sample; *D*, expansion of sample.

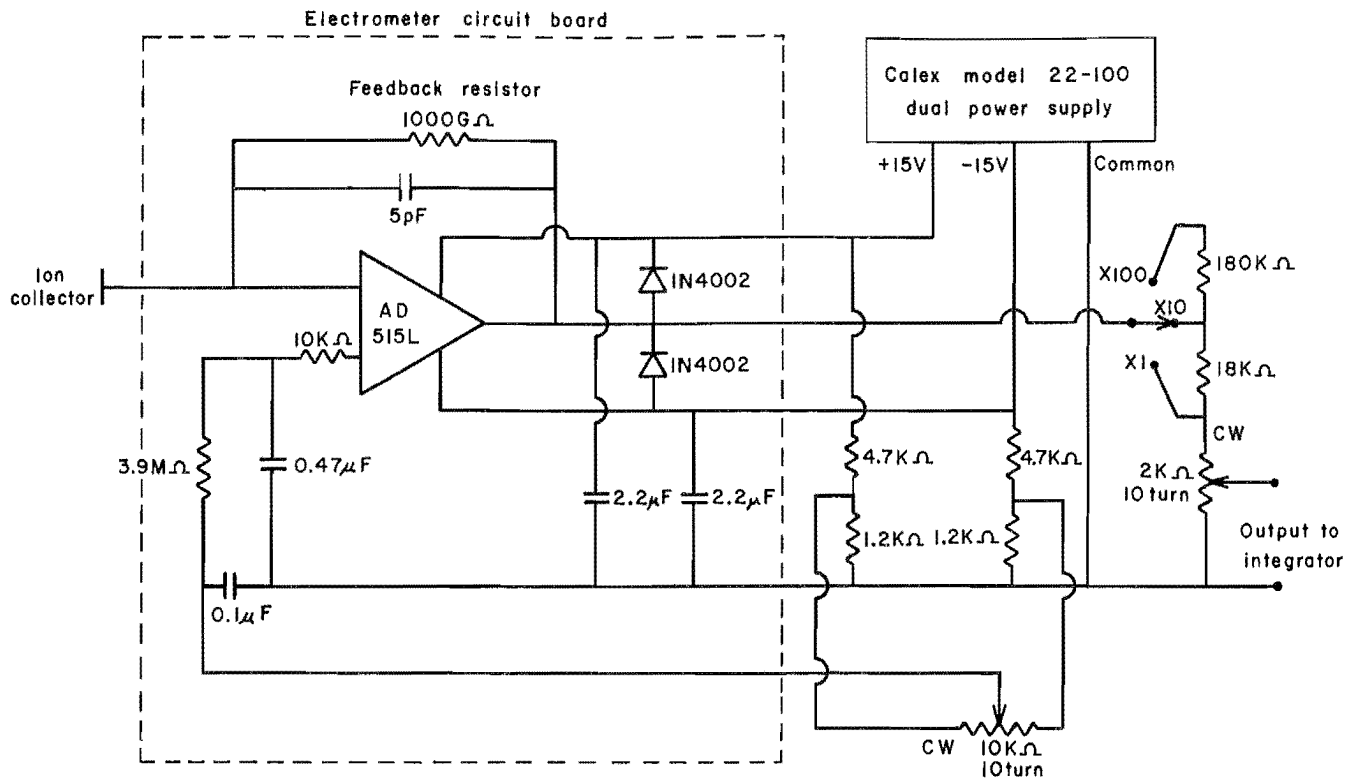

FIGURE 3. - Schematic diagram of electrometer.

risers above 0.2 mtorr during the charcoal bakeout, the filament-protection circuit will automatically switch off the filament in the ion source. After the pressure drops below 0.2 mtorr the filament is reset manually.) After the trap has cooled, the liquid nitrogen dewar is raised so that the liquid level is about 5 cm above the bulb in the trap. The charcoal provides enough adsorptive capacity for about 200 sample injections.

ANALYSIS OF SAMPLES

The reference gas and sample supply lines are connected to inlet ports A and B as shown in figure 1. By keying in an "Ext 7" command at the integrator keyboard, valve 1 is switched, which allows the reference gas flow to be measured with the rotameter (fig. 2A). Using valve 6, the flow is set between 10 and 25 cm³/min. Valve 1 is then switched off (using a "-Ext 7" command) to allow the sample flow to be measured with the

rotameter (fig. 2C). The sample flow is set between 10 and 25 cm³/min using valve 7.

For automated alternate analysis of the reference gas and sample, the time-programmed sequence of valve operations shown in table 1 is used. The time-programmed commands for the valve operations and their times of execution are entered into the integrator memory via keyboard. Peak integration parameters are set as shown in table 2. The integrator's "peak-height-mode" option (OP #4) is used so that the helium peaks are quantized according to their heights. The integrator's "automate-runs" option (OP #10) is activated to cause the programmed sequence of valve operations to be repeated after data are printed. The programmed valve sequence is initiated by depressing the integrator "start" button. The sequence is repeated continuously until manually terminated by the "stop" button.

TABLE 1. - Time-programmed valve sequence for automated analysis

Integrator time-programmed command	Time of execution (from start of run), min	Operation ¹	Result of operation ¹
Ext 7.....	0.01	Close valve 1 (air on).	Purge sample loop with reference gas (fig. 2A).
Ext 5.....	.50	Close valve 2 (air on).	Expand reference gas into mass spectrometer (fig. 2B).
-Ext 5.....	2.50	Open valve 2 (air off).	Return valve 2 to purge position (fig. 2A).
-Ext 7.....	2.51	Open valve 1 (air off).	Purge sample loop with sample (fig. 2C).
Ext 5.....	3.00	Close valve 2 (air on).	Expand sample into mass spectrometer (fig. 2D).
-Ext 5.....	5.00	Open valve 2 (air off).	Return valve 2 to purge position (fig. 2C).

¹References are to valves 1 and 2 as shown in figures 1 and 2.

TABLE 2. - Integration parameters for quantization and plotting of helium peaks

Integrator parameter key	Description of parameter	Parameter setting
PK WD.....	Peak width--time width of peak at half height (min).	0.01
THRSH.....	Threshold--discrimination level for eliminating signal changes regarded as noise. (Values entered are integer powers of 2.)	3
ATT 2+.....	Attenuation--plot height scale. (Values entered are integer powers of 2.)	0-10
CHT SP.....	Chart speed--plot width scale (cm/min).	0.5

DISCUSSION OF RESULTS

LINEARITY

To determine the linearity of the method, four helium-in-nitrogen weighed primary standards were analyzed. The standards were prepared by successive dilution of helium with analyzed nitrogen⁷ until the desired concentration in the parts-per-billion range was achieved (7-8). Each standard was analyzed 10 times. A comparison of the weighed standard helium contents and the

corresponding mass spectral mean peak heights (table 3) shows the system to be linear over the investigated range of about 50 to 20,000 ppb. Electrical saturation of the electrometer was calculated to occur at a sample helium concentration of about 22,000 ppb.

TABLE 3. - Linearity of the method

Helium content of weighed primary standard, ppb	Mean peak height, μ V	Mean peak height, μ V/ppb
52.5 \pm 2.5....	240	4.571
889.8 \pm 1.1....	4,130	4.641
5,486 \pm 7.....	25,400	4.630
19,627 \pm 13.....	91,090	4.641

⁷Nitrogen analyzed to contain less than the calculated minimum detectable concentration of 5 ppb helium was assumed to have a helium concentration of 0 ppb.

ACCURACY

To evaluate the accuracy of the method, the four helium-in-nitrogen standards used in the linearity study were compared. Using the standard containing 19,627 ppb He as a reference, the standards containing 889.8 ppb and 5,486 ppb He were analyzed as unknown samples. Then, using the 889.8-ppb-He standard as a reference, the standard containing 52.5 ppb He was analyzed as an unknown. Subsequently, the 19,627-ppb standard was used as a reference for itself. The hypothetical unknown samples were analyzed 20 times in succession. Each sample analysis was bracketed by analyses of the reference. The results in table 4 show that accuracy at the 95-pct confidence level over the investigated range was within ± 2 ppb or ± 0.4 pct, whichever was greater.

EFFECT OF SAMPLE FLOW

The effect of sample flow on analysis was determined as follows: A helium-enriched air sample was analyzed 20 times with the sample and reference gas flows set at 10 and 25 cm³/min, respectively. The sample was then analyzed an additional 20 times with the sample and reference gas flows set at 25 and 10 cm³/min, respectively. The reference gas used was a helium-in-nitrogen weighed primary standard containing 5,486 \pm 7 ppb He.

The mean helium contents (with standard deviation) for the two 20-analysis sets were 5,323 \pm 10 ppb He in both instances. Thus, it was concluded that as long as the sample and reference gas flows were maintained between 10 and 25 cm³/min, there was no detectable effect on the analytical results.

CALCULATIONS

Gradual temperature changes in the electrometer can cause the helium sensitivity to increase or decrease by as much as 1 to 2 pct/h. To correct for this drift in sensitivity, a weighed primary standard is analyzed before and after each unknown sample. The helium content of the sample is calculated using an average helium sensitivity as shown in the equation

$$He_u = \frac{He_s}{\frac{D_{s(1)} + D_{s(2)}}{2}} \cdot D_u,$$

He_s = helium content of standard, ppb,

$D_{s(1)}$ = helium peak height from first analysis of the standard, μV ,

$D_{s(2)}$ = helium peak height from second analysis of the standard, μV ,

and D_u = helium peak height of unknown sample, μV .

where He_u = helium content of unknown sample, ppb,

TABLE 4. - Accuracy of the method, parts per billion

Helium in nitrogen		Mean helium content for 20 analyses	Accuracy at 95-pct confidence
Reference	Sample		
889.8 \pm 1.1	52.5 \pm 2.5	52	± 2
19,627 ± 13	889.8 \pm 1.1	890	± 4
19,627 ± 13	5,486 ± 7	5,502	± 18
19,627 ± 13	19,627 ± 13	19,619	± 76

CONCLUSIONS

The analyzer described provides a precise and reliable method for determining helium in the parts-per-billion range. Accuracy at the 95-pct confidence level in the 50- to 20,000-ppb range is within

± 2 ppb or ± 0.4 pct, whichever is greater. The minimum detectable helium concentration is calculated to be ± 5 ppb. The portability of the analyzer allows it to be used in the field.

REFERENCES

1. Carter, R. C., D. K. Todd, G. T. Orlob, and W. J. Kaufman. Measurement of Helium in Ground Water Tracing. Water Resour. Center, Univ. of CA, Berkeley, CA, Contribution 21, Jan. 15, 1959, 54 pp.
2. Friedman, I., and E. H. Denton. A Portable Helium Sniffer. U.S. Geol. Surv. OFR 75-532, 1975, 6 pp.
3. Reimer, G. M. Design and Assembly of a Portable Helium Detector for Evaluation as a Uranium Exploration Instrument. U.S. Geol. Surv. OFR 76-398, 1976, 18 pp.
4. Reimer, G. M., and E. H. Denton. Improved Inlet System for the U.S. Geol. Survey Helium Sniffer. U.S. Geol. Surv. OFR 78-588, 1978, 4 pp.
5. Dyck, W., and J. C. Pelchat. A Semiportable Helium Analysis Facility. Report of Activities, Part C. Geol. Surv. of Canada Paper 77-IC, 1977, pp. 85-87.
6. Martin, J. P., and L. E. Berquist. Study of the Applicability of $^3\text{He}/^4\text{He}$ Ratio for Uranium Prospecting. (U.S. DOE contract GJBX58(77), Martin Marietta Corp.). Sept. 1977, 97 pp.; available for consultation at the U.S. DOE, Grand Junction, CO.
7. Loya, E. W., C. A. Seitz, and D. E. Emerson. Gravimetric Preparation of Primary Standard Gas Mixtures in the Parts Per Trillion Range. BuMines RI 8643, 1982, 4 pp.
8. Miller, J. E., A. J. Carroll, and D. E. Emerson. Preparation of Primary Standard Gas Mixtures for Analytical Instruments. BuMines RI 6674, 1965, 10 pp.